



CERTIFICATION TEST REPORT

Report Number. : 16U23555-E3V3

Applicant : Google Inc.
1600 Amphitheatre Parkway
Mountain View, CA 94043 U.S.A

Model : NC2-6A5-D

FCC ID : A4RNC2-6A5-D

IC ID : 10395A-NC26A5D

EUT Description : Internet Video Streaming Device

Test Standard(s) : FCC 47 CFR PART 15 SUBPART C
INDUSTRY CANADA RSS-247 ISSUE 1

Date of Issue:

Tuesday, August 16, 2016

Prepared by:

UL Verification Services Inc.
47173 Benicia Street
Fremont, CA 94538, U.S.A.
TEL: (510) 771-1000
FAX: (510) 661-0888



NVLAP LAB CODE 200065-0

REPORT REVISION HISTORY

Rev.	Issue Date	Revisions	Revised By
V1	7/25/2016	Initial Issue	---
V2	7/28/2016	Revision to EUT Description	Grace Rincand
V3	8/16/2016	Updated sections 4.1 and 4.5	Francisco de Anda

TABLE OF CONTENTS

REPORT REVISION HISTORY	2
TABLE OF CONTENTS	3
1. ATTESTATION OF TEST RESULTS	4
2. SUMMARY OF TESTING	5
2.1. <i>FACILITIES AND ACCREDITATION</i>	<i>5</i>
2.2. <i>TEST METHODOLOGY.....</i>	<i>5</i>
2.3. <i>CALIBRATION AND UNCERTAINTY</i>	<i>6</i>
2.4. <i>MEASUREMENT METHOD.....</i>	<i>7</i>
2.5. <i>TEST AND MEASUREMENT EQUIPMENT.....</i>	<i>8</i>
3. EQUIPMENT UNDER TEST	9
3.1. <i>MAXIMUM OUTPUT POWER.....</i>	<i>9</i>
3.2. <i>DESCRIPTION OF AVAILABLE ANTENNAS</i>	<i>9</i>
3.3. <i>WORST-CASE CONFIGURATION AND MODE.....</i>	<i>9</i>
3.4. <i>DESCRIPTION OF TEST SETUP.....</i>	<i>10</i>
4. ANTENNA PORT TEST RESULTS	14
4.1. <i>ON TIME, DUTY CYCLE</i>	<i>14</i>
4.2. <i>6 dB BANDWIDTH.....</i>	<i>15</i>
4.3. <i>99% BANDWIDTH.....</i>	<i>17</i>
4.4. <i>OUTPUT POWER.....</i>	<i>18</i>
4.5. <i>AVERAGE POWER.....</i>	<i>20</i>
4.6. <i>POWER SPECTRAL DENSITY</i>	<i>21</i>
4.7. <i>CONDUCTED SPURIOUS EMISSIONS.....</i>	<i>23</i>
5. RADIATED TEST RESULTS.....	26
5.1. <i>LIMITS AND PROCEDURE</i>	<i>26</i>
5.2. <i>TRANSMITTER ABOVE 1 GHz.....</i>	<i>27</i>
5.3. <i>WORST-CASE BELOW 1 GHz.....</i>	<i>37</i>
5.4. <i>WORST-CASE 18 GHz – 26 GHz.....</i>	<i>39</i>
5.5. <i>AC POWER LINE CONDUCTED EMISSIONS</i>	<i>41</i>
6. SETUP PHOTOS.....	44

1. ATTESTATION OF TEST RESULTS

COMPANY NAME: Google Inc.
1600 Amphitheatre Parkway
Mountain View, CA 94043 U.S.A

EUT DESCRIPTION: Internet Video Streaming Device

MODEL: NC2-6A5-D

SERIAL NUMBER: 6520CZZAXW (Radiated); Proto 1 (Conducted)

DATE TESTED: JULY 1ST 2016 – AUGUST 16TH 2016

APPLICABLE STANDARDS	
STANDARD	TEST RESULTS
CFR 47 Part 15 Subpart C	Pass
INDUSTRY CANADA RSS-247 Issue 1	Pass
INDUSTRY CANADA RSS-GEN Issue 4	Pass

UL Verification Services Inc. tested the above equipment in accordance with the requirements set forth in the above standards. All indications of Pass/Fail in this report are opinions expressed by UL Verification Services Inc. based on interpretations and/or observations of test results. Measurement Uncertainties were not taken into account and are published for informational purposes only. The test results show that the equipment tested is capable of demonstrating compliance with the requirements as documented in this report.

Note: The results documented in this report apply only to the tested sample, under the conditions and modes of operation as described herein. This document may not be altered or revised in any way unless done so by UL Verification Services Inc. and all revisions are duly noted in the revisions section. Any alteration of this document not carried out by UL Verification Services Inc. will constitute fraud and shall nullify the document. This report must not be used by the client to claim product certification, approval, or endorsement by NVLAP, NIST, any agency of the Federal Government, or any agency of any government.

Approved & Released For
UL Verification Services Inc. By:

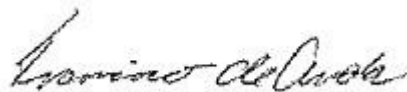

Francisco de Anda
CONSUMER TECHNOLOGY DIVISION
Program Manager
UL Verification Services Inc.

Prepared By:



Clifford Susa
CONSUMER TECHNOLOGY DIVISION
Lab Engineer
UL Verification Services Inc.

2. SUMMARY OF TESTING

2.1. FACILITIES AND ACCREDITATION

The test sites and measurement facilities used to collect data are located at 47173 and 47266 Benicia Street, Fremont, California, USA. Line conducted emissions are measured only at the 47173 address. The following table identifies which facilities were utilized for radiated emission measurements documented in this report. Specific facilities are also identified in the test results sections.

47173 Benicia Street	47266 Benicia Street
<input type="checkbox"/> Chamber A(IC: 2324B-1)	<input type="checkbox"/> Chamber D(IC: 2324B-4)
<input checked="" type="checkbox"/> Chamber B(IC: 2324B-2)	<input type="checkbox"/> Chamber E(IC: 2324B-5)
<input type="checkbox"/> Chamber C(IC: 2324B-3)	<input type="checkbox"/> Chamber F(IC: 2324B-6)
	<input type="checkbox"/> Chamber G(IC: 2324B-7)
	<input type="checkbox"/> Chamber H(IC: 2324B-8)

UL Verification Services Inc. is accredited by NVLAP, Laboratory Code 200065-0. The full scope of accreditation can be viewed at <http://ts.nist.gov/standards/scopes/2000650.htm>.

2.2. TEST METHODOLOGY

The tests documented in this report were performed in accordance with ANSI C63.10-2013, FCC CFR 47 Part 2, FCC CFR 47 Part 15, RSS-GEN Issue 4, and RSS-247 Issue 1.

2.3. CALIBRATION AND UNCERTAINTY

MEASURING INSTRUMENT CALIBRATION

The measuring equipment utilized to perform the tests documented in this report has been calibrated in accordance with the manufacturer's recommendations, and is traceable to recognized national standards.

SAMPLE CALCULATION

Where relevant, the following sample calculation is provided:

$$\begin{aligned} \text{Field Strength (dBuV/m)} &= \text{Measured Voltage (dBuV)} + \text{Antenna Factor (dB/m)} + \\ &\text{Cable Loss (dB)} - \text{Preamp Gain (dB)} \\ 36.5 \text{ dBuV} + 18.7 \text{ dB/m} + 0.6 \text{ dB} - 26.9 \text{ dB} &= 28.9 \text{ dBuV/m} \end{aligned}$$

MEASUREMENT UNCERTAINTY

Where relevant, the following measurement uncertainty levels have been estimated for tests performed on the apparatus:

PARAMETER	UNCERTAINTY
Conducted Disturbance, 9KHz to 0.15 MHz	3.84 dB
Conducted Disturbance, 0.15 to 30 MHz	3.65 dB
Radiated Disturbance, 9KHz to 30 MHz	3.15 dB
Radiated Disturbance, 30 to 1000 MHz	5.36 dB
Radiated Disturbance, 1000 to 18000 MHz	4.32 dB
Radiated Disturbance, 18000 to 26000 MHz	4.45 dB
Radiated Disturbance, 26000 to 40000 MHz	5.24 dB

Uncertainty figures are valid to a confidence level of 95%.

2.4. MEASUREMENT METHOD

On Time and Duty Cycle: KDB 558074 D01 v03r05, Section 6.

6 dB Emission BW: KDB 558074 D01 v03r05, Section 8.

Conducted Output Power: KDB 558074 D01 v03r05, Section 9.1.1 (Method RBW \geq DTS bandwidth).

Average Power: KDB 558074 D01 v03r05, Section 9.2.3.2 (Method AVGPM-G).

Power Spectral Density: KDB 558074 D01 v03r05, Section 10.2 (Method PKPSD).

Unwanted emissions in restricted bands: KDB 558074 D01 v03r05, Section 12.0, 12.2.

Unwanted emissions in non-restricted bands: KDB 558074 D01 v03r05, Section 11.1, 11.2, and 11.3

AC Power Line Conducted Emissions: ANSI C63.10-2009, Section 6.2.

2.5. TEST AND MEASUREMENT EQUIPMENT

The following test and measurement equipment was utilized for the tests documented in this report:

Test Equipment List				
Description	Manufacturer	Model	ID Num	Cal Due
Antenna, Biconolog, 30MHz-1 GHz	Sunol Sciences	JB1	T130	09/01/16
Antenna, Horn, 1-18GHz	ETS Lindgren	3117	T345	03/07/17
Antenna, Horn, 18-26 GHz	ARA	MWH-1826/B	T449	05/26/17
RF Preampifier, 10kHz - 1GHz	HP	8447D	T10	02/01/17
RF Preampifier, 1 - 18GHz	Miteq	AFS42-00101800-25-S-42	T493	03/09/17
RF Preampifier, 1 - 8GHz	Miteq	AMF-4D-01000800-30-29P	T1156	03/09/17
RF Preampifier, 1 - 26GHz	Agilent	8449B	T404	07/05/17
Spectrum Analyzer, 44 GHz	Keysight	N9030A	T907	01/06/17
Spectrum Analyzer, 44 GHz	Keysight	E440A	T198	12/12/16
Spectrum Analyzer, 40 GHz	HP	8564E	T106	08/14/16
EMI Test Receiver, 9 kHz to 7 GHz	Rohde & Schwarz	ESR	T1436	12/19/16
Power Meter	Keysight	N1911A	T229	07/30/16
Power Sensor	Keysight	N1921A	T1223	02/28/17
LISN, 30 MHz	FCC	FCC-LISN-50/250-25-2-01	T1310	06/08/17
Low Pass Filter 3GHz	Micro-Tronics	HPM17543	T485	3/9/2017

Test Software List			
Description	Manufacturer	Model	Version
Radiated Software	UL	UL EMC	9.5, 4/26/16
Antenna Port Software	UL	UL RF	5.0, 6/22/16
Conducted Emissions Software	UL	UL EMC	9.5, 5/26/15

3. EQUIPMENT UNDER TEST

3.1. MAXIMUM OUTPUT POWER

The transmitter has a maximum peak conducted output power as follows:

Frequency Range (MHz)	Mode	Output Power (dBm)	Output Power (mW)
2402 - 2480	BLE	4.48	2.80

The transmitter has a maximum average conducted output power as follows:

Frequency Range (MHz)	Mode	Output Power (dBm)	Output Power (mW)
2402 - 2480	BLE	4.44	2.78

3.2. DESCRIPTION OF AVAILABLE ANTENNAS

The radio utilizes a PCB antenna, with a maximum gain of 4.9 dBi.

3.3. WORST-CASE CONFIGURATION AND MODE

Radiated emission and power line conducted emission were performed with the EUT set to transmit at the channel with highest output power as worst-case scenario.

The fundamental of the EUT was investigated in three orthogonal orientations X,Y,Z, it was determined that X orientation was worst-case orientation; therefore, all final radiated testing was performed with the EUT in X orientation.

Worst-case data rates as provided by the client were:

BLE: 1Mbps

3.4. DESCRIPTION OF TEST SETUP

SUPPORT EQUIPMENT

Support Equipment List				
Description	Manufacturer	Model	Serial Number	FCC ID
AC Adapter	HP	HSTNN-LA40	WDUV0B3U8HK1Y	DoC
Laptop	HP	11-d001ax	5CD51643JG	DoC

I/O CABLES

I/O Cable List						
Cable No	Port	# of identical ports	Connector Type	Cable Type	Cable Length (m)	Remarks
1	USB	1	Micro USB	unshielded	2	
2	USB	1	Micro USB	unshielded	0.2	Y-cable
3	USB	1	USB	unshielded	2.5	USB serial cable
4	DC	1	Barrel	unshielded	1.7	
5	AC	1	3 prong	unshielded	1	

TEST SETUP

The EUT is connected to a test laptop during the tests. Test software exercised the radio card.

SOFTWARE AND FIRMWARE

The firmware installed in the EUT during testing was 16.80.205.82

The test utility software used during testing was Labtool ver. 1.0.0.82.

SETUP DIAGRAM FOR CONDUCTED TESTS

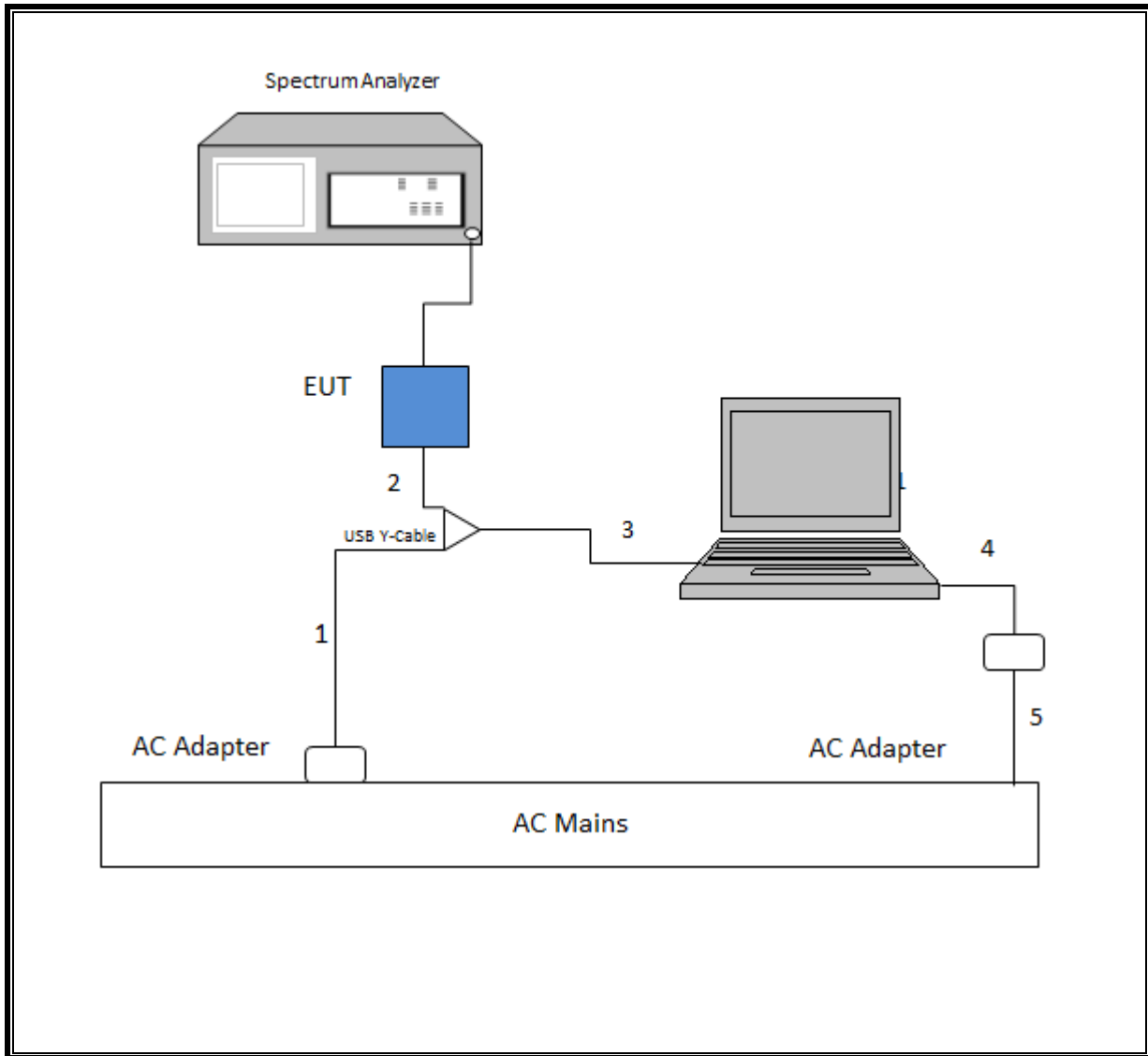

SETUP DIAGRAM FOR RADIATED TESTS

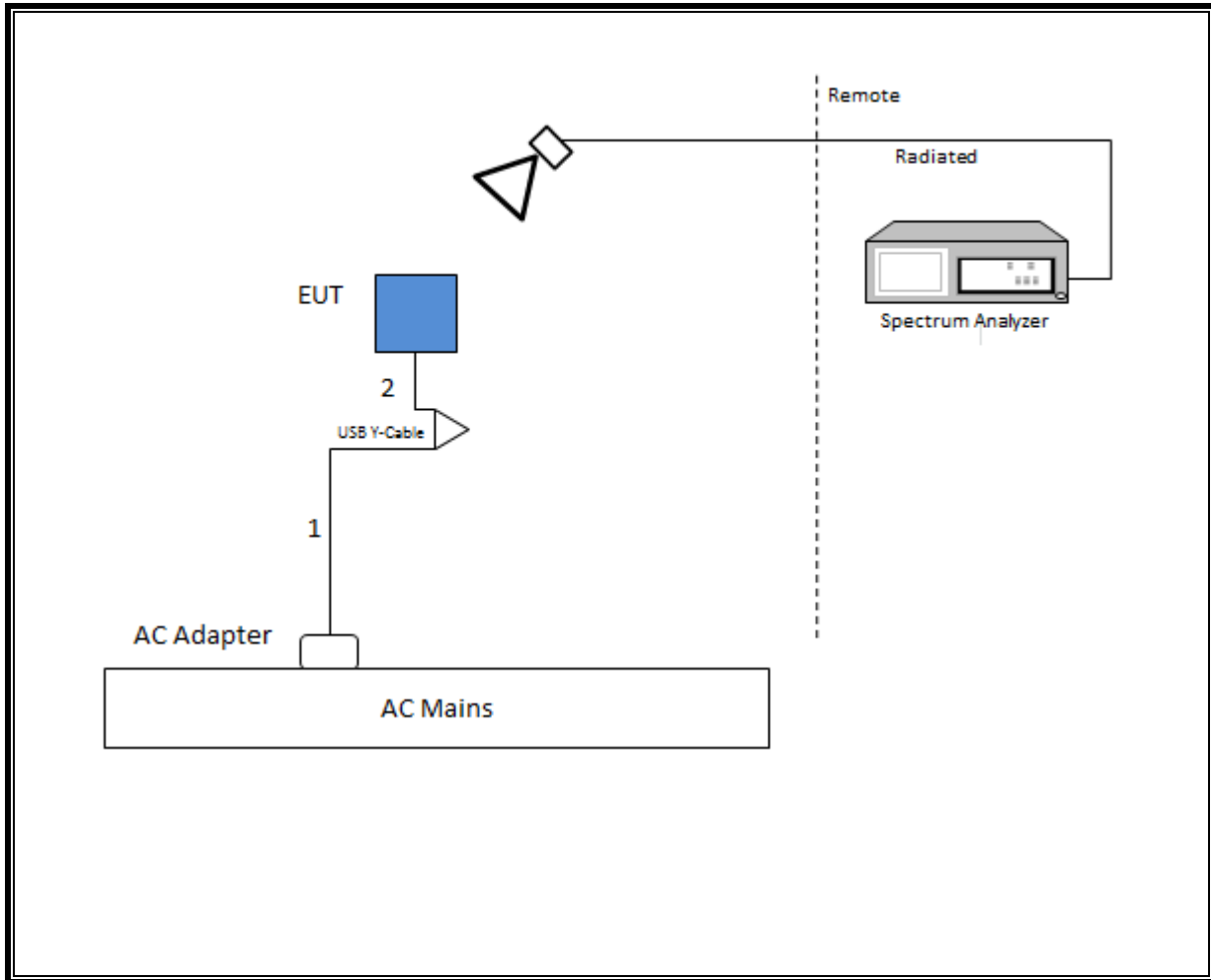

SETUP DIAGRAM FOR LINE CONDUCTED TEST

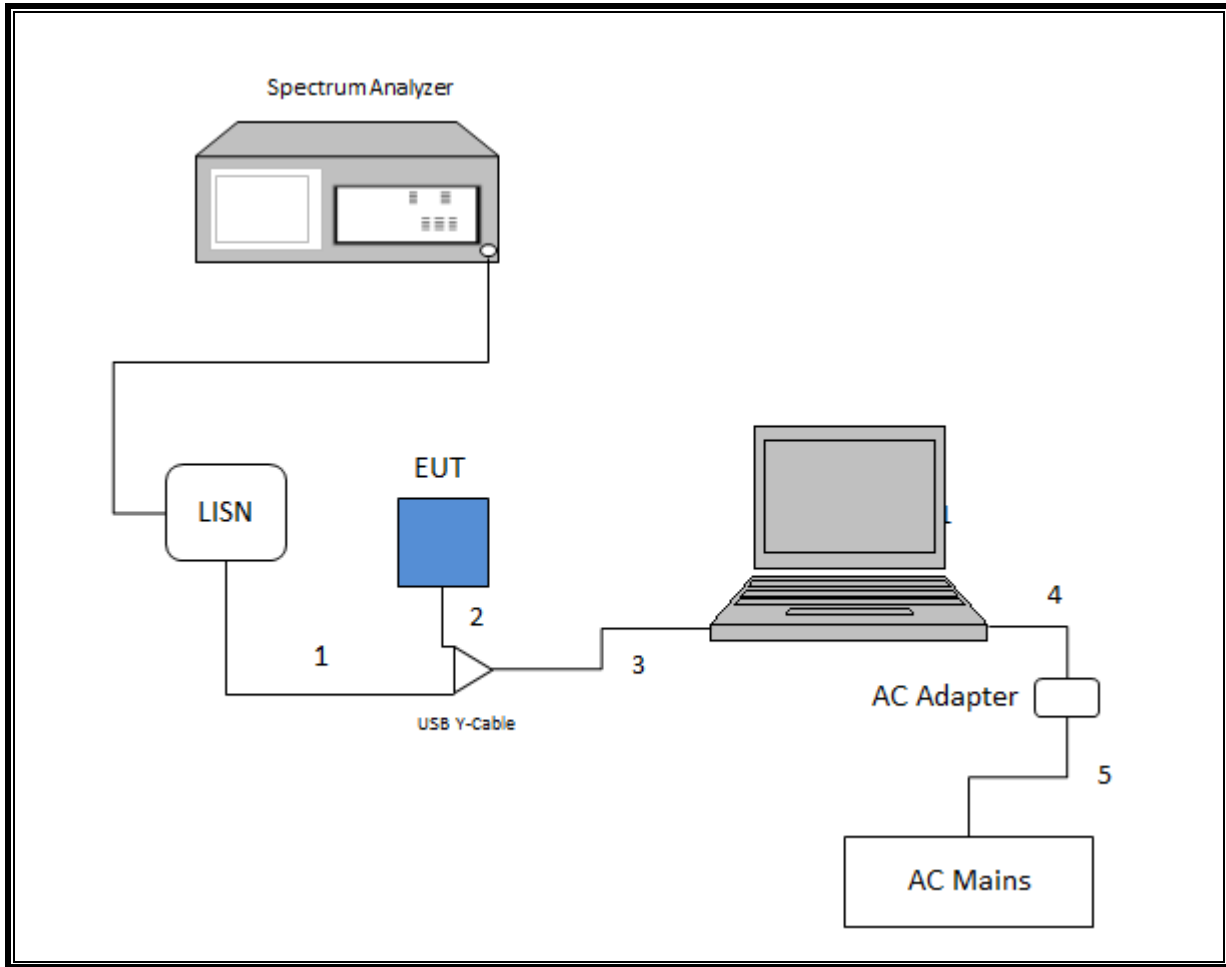

4. ANTENNA PORT TEST RESULTS

4.1. ON TIME, DUTY CYCLE

LIMITS

None; for reporting purposes only.

ON TIME AND DUTY CYCLE RESULTS

Tested by: 39316 CX

Date: 7/1/2016

Mode	ON Time B (usec)	Period (usec)	Duty Cycle x (linear)	Duty Cycle (%)	Duty Cycle Correction Factor (dB)	1/B Minimum VBW (MHz)
BLE	384.00	624.00	0.615	61.54%	2.11	0.0026

DUTY CYCLE PLOTS



4.2. 6 dB BANDWIDTH

LIMITS

FCC §15.247 (a) (2)

IC RSS-247 5.2.1

The minimum 6 dB bandwidth shall be at least 500 kHz.

RESULTS

Channel	Frequency (MHz)	6 dB Bandwidth (MHz)	Minimum Limit (MHz)
Low	2402	0.6740	0.5
Middle	2440	0.6720	0.5
High	2480	0.6820	0.5

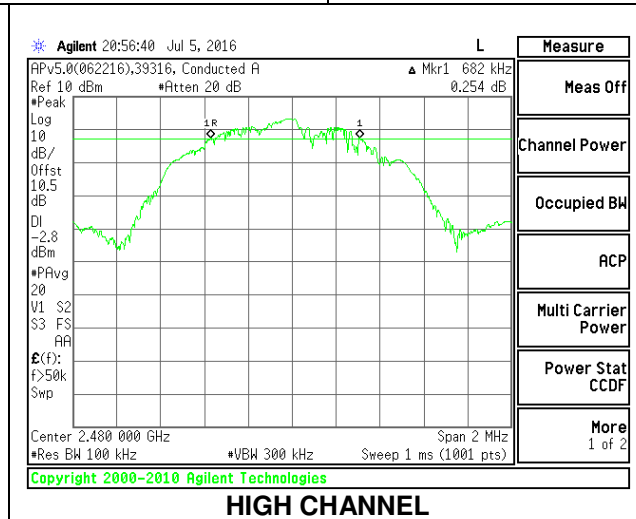
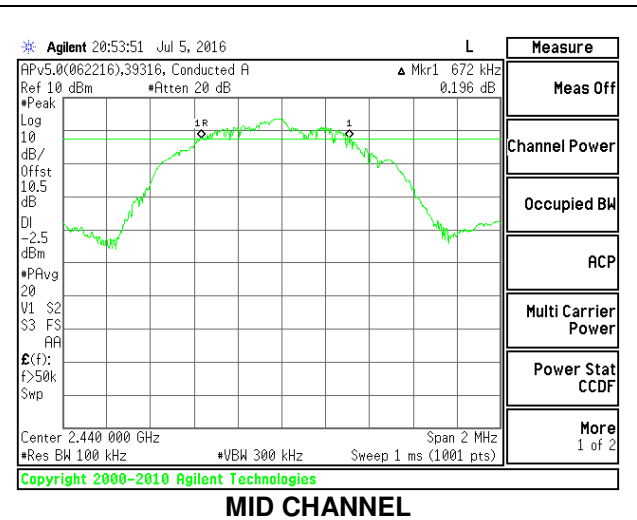
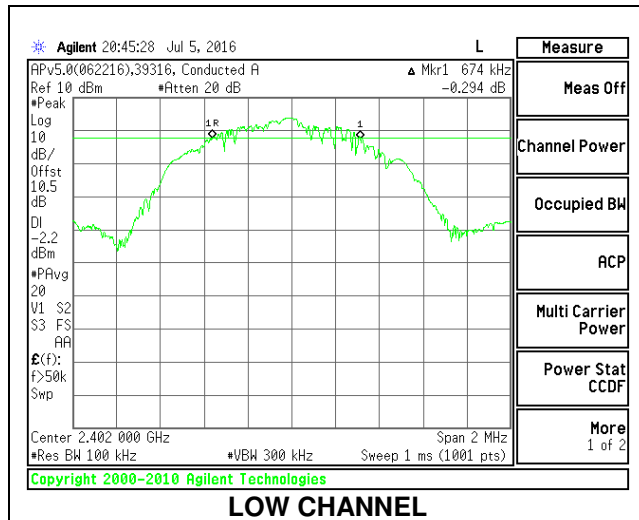

4.3. 99% BANDWIDTH

LIMITS

None; for reporting purposes only.

RESULTS

Channel	Frequency (MHz)	99% Bandwidth (MHz)
Low	2402	1.0263
Middle	2440	1.0262
High	2480	1.0266

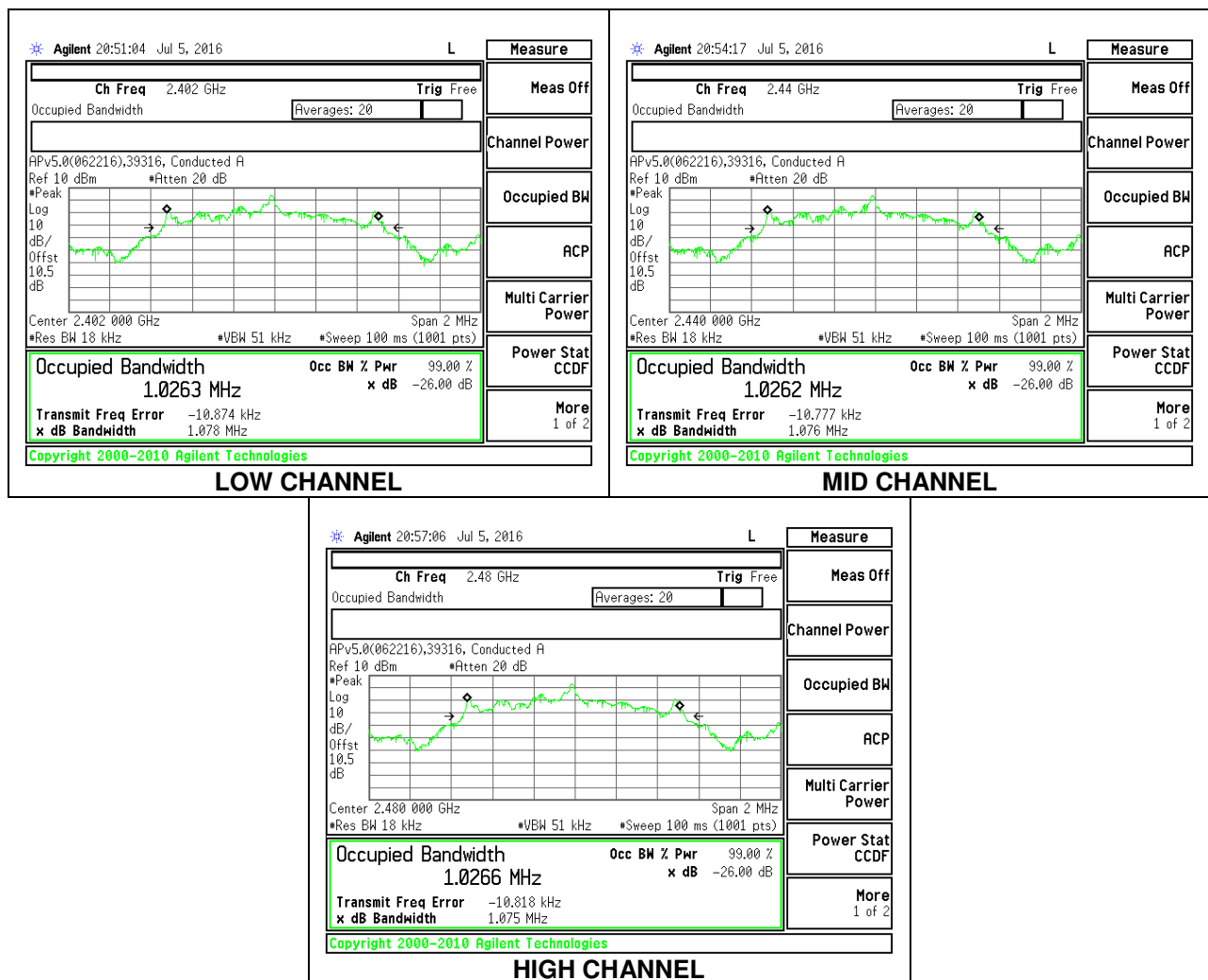

4.4. OUTPUT POWER

LIMITS

FCC §15.247 (b)

IC RSS-247 5.4.4

The maximum antenna gain is less than or equal to 6 dBi, therefore the limit is 30 dBm.

RESULTS

Tested By:	39316 CX
Date:	7/5/2016

Channel	Frequency (MHz)	Peak Power Reading (dBm)	Limit (dBm)	Margin (dB)
Low	2402	4.48	30	-25.524
Middle	2440	4.14	30	-25.858
High	2480	3.86	30	-26.144

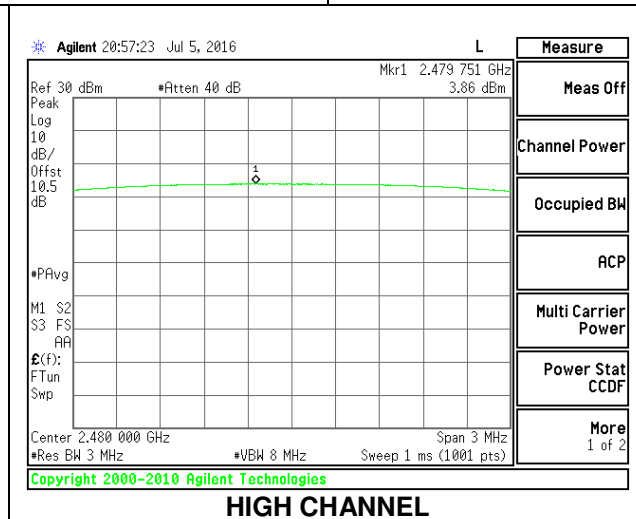
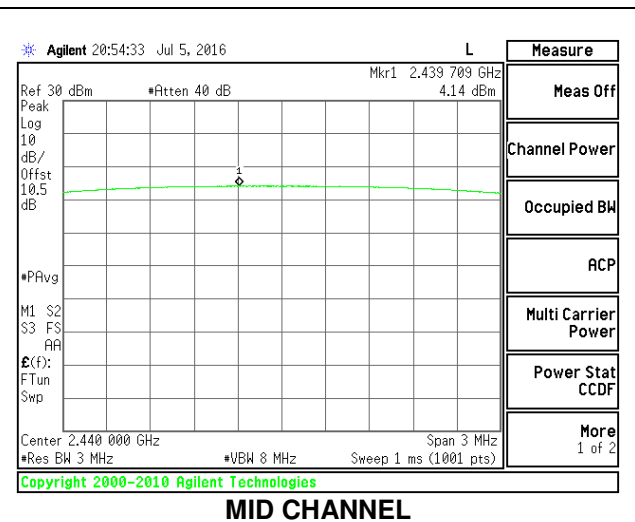
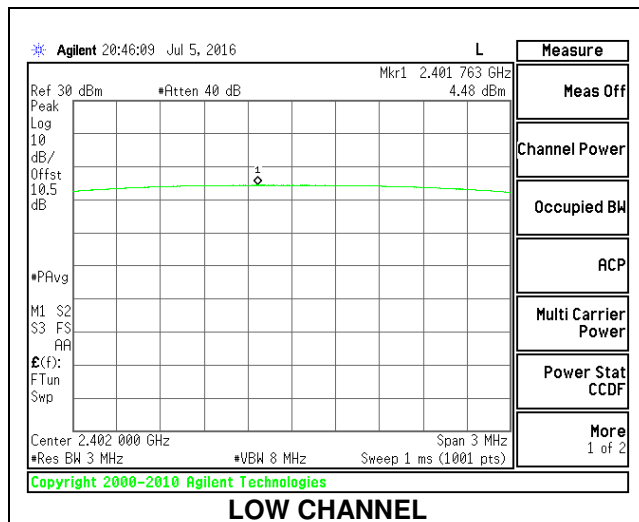

4.5. AVERAGE POWER

LIMITS

None; for reporting purposes only.

RESULTS

Tested By:	39316 CX
Date:	8/16/2016

Channel	Frequency (MHz)	AV power (dBm)
Low	2402	4.44
Middle	2440	4.01
High	2480	3.79

4.6. POWER SPECTRAL DENSITY

LIMITS

FCC §15.247 (e)

IC RSS-247 5.2.2

The power spectral density conducted from the transmitter to the antenna shall not be greater than 8 dBm in any 3 kHz band during any time interval of continuous transmission.

RESULTS

Channel	Frequency (MHz)	PSD (dBm)	Limit (dBm)	Margin (dB)
Low	2402	3.77	8	-4.23
Middle	2440	3.51	8	-4.49
High	2480	3.20	8	-4.80

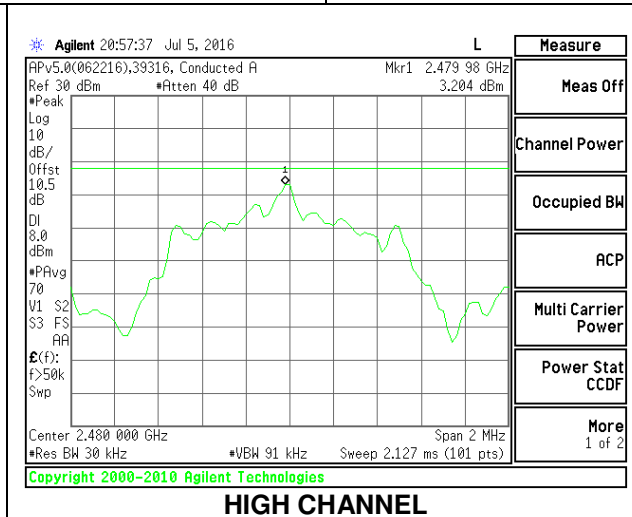
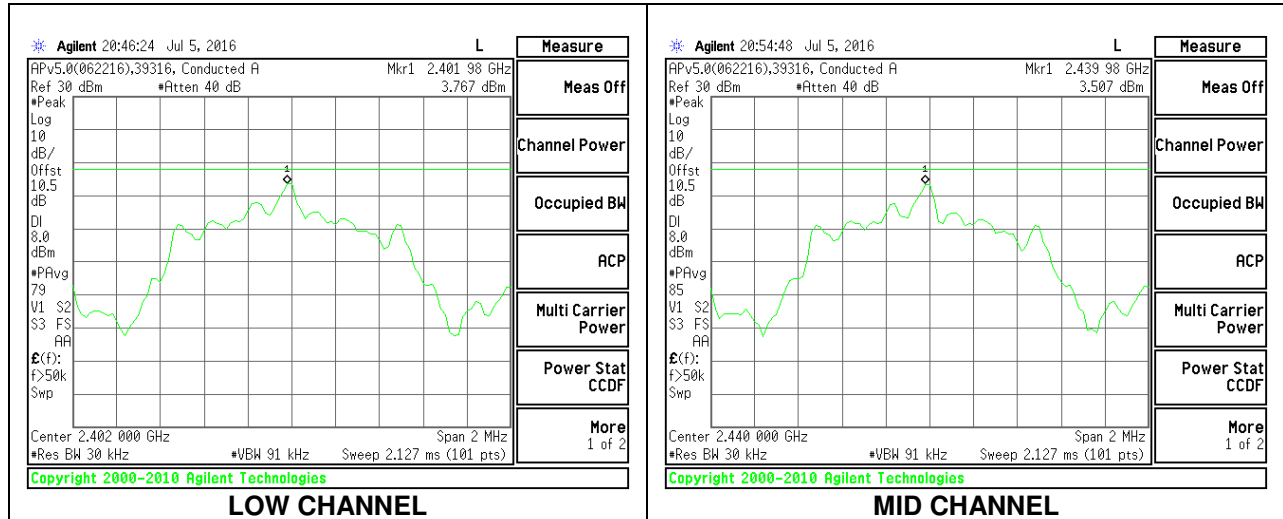

4.7. CONDUCTED SPURIOUS EMISSIONS

LIMITS

FCC §15.247 (d)

IC RSS-247 5.5

Output power was measured based on the use of a peak measurement, therefore the required attenuation is 20 dB.

RESULTS

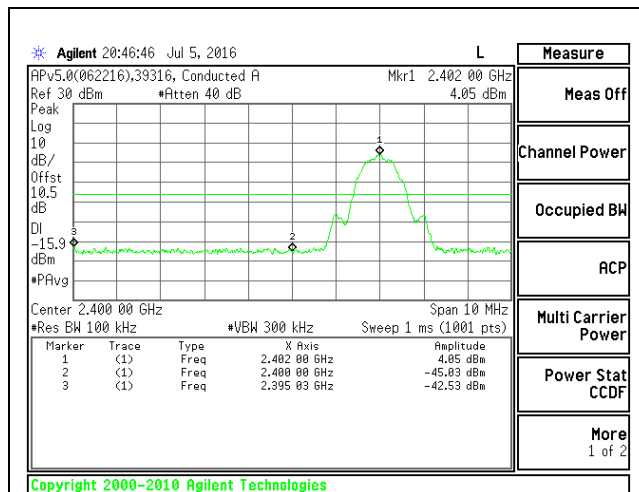

LOW CHANNEL BANDEDGE

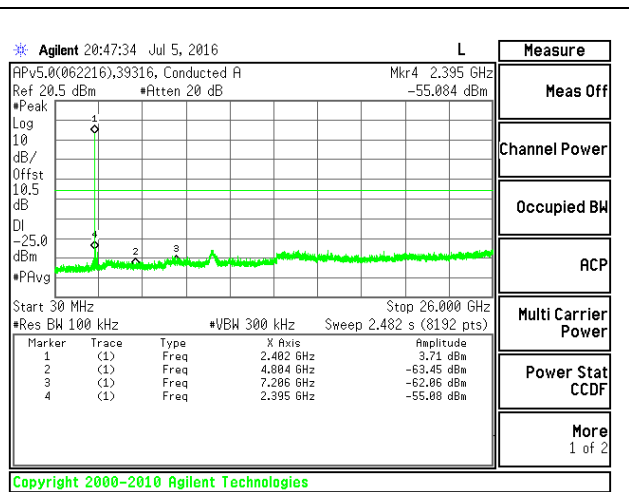

OUT OF BAND LOW CHANNEL

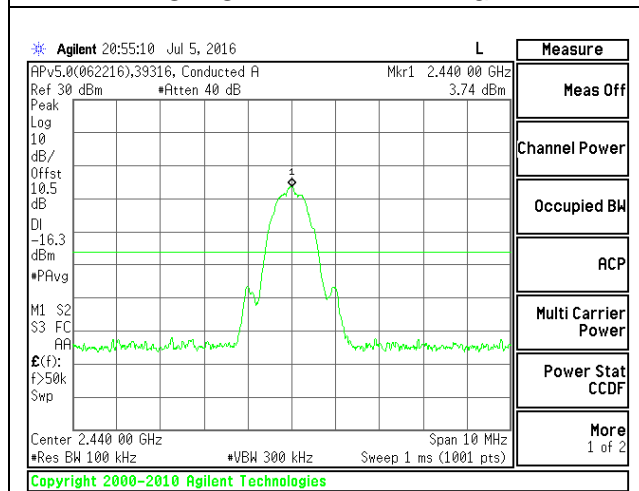

IN-BAND REFERENCE LEVEL

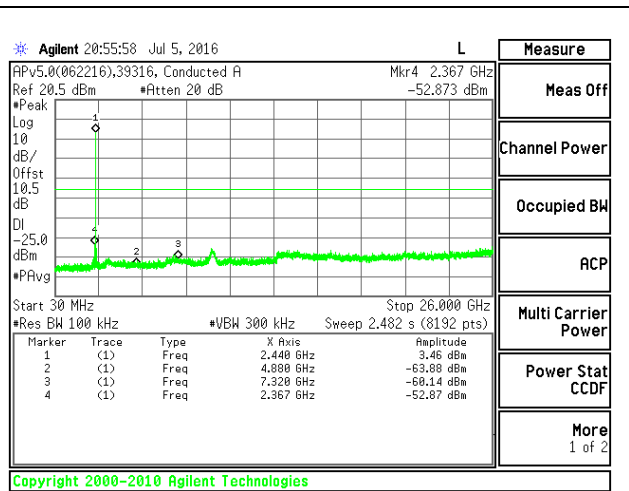

OUT OF BAND MID CHANNEL

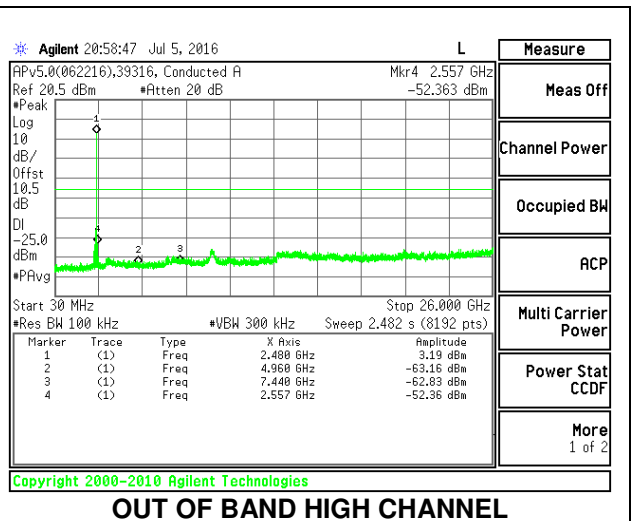
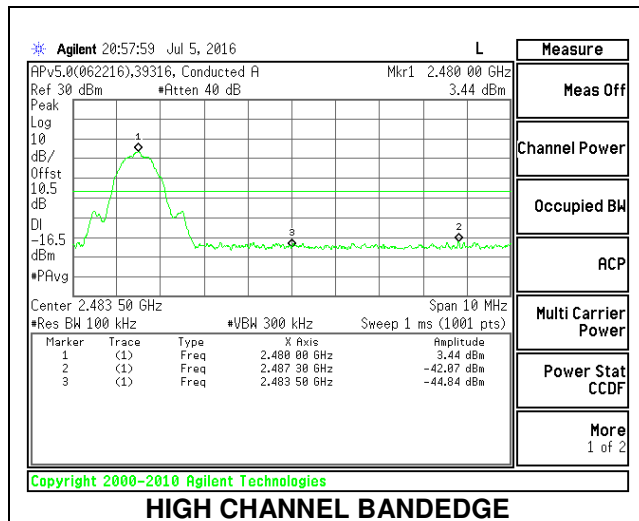

5. RADIATED TEST RESULTS

5.1. LIMITS AND PROCEDURE

LIMITS

FCC §15.205 and §15.209

IC RSS-GEN Clause 8.9 (Transmitter)

IC RSS-GEN Clause 7 (Receiver)

Frequency Range (MHz)	Field Strength Limit (uV/m) at 3 m	Field Strength Limit (dBuV/m) at 3 m
30 - 88	100	40
88 - 216	150	43.5
216 - 960	200	46
Above 960	500	54

TEST PROCEDURE

The EUT is placed on a non-conducting table 80 cm above the ground plane for below 1GHz and 150cm for above 1GHz. The antenna to EUT distance is 3 meters. The EUT is configured in accordance with ANSI C63.10. The EUT is set to transmit in a continuous mode.

For measurements below 1 GHz the resolution bandwidth is set to 100 kHz for peak detection measurements or 120 kHz for quasi-peak detection measurements. Peak detection is used unless otherwise noted as quasi-peak.

For measurements above 1 GHz the resolution bandwidth is set to 1 MHz, then the video bandwidth is set to 1 MHz for peak measurements and add duty cycle factor for average measurements.

The spectrum from 30 MHz to 26 GHz is investigated with the transmitter set to the lowest, middle, and highest channels in the 2.4 GHz band.

The frequency range of interest is monitored at a fixed antenna height and EUT azimuth. The EUT is rotated through 360 degrees to maximize emissions received. The antenna is scanned from 1 to 4 meters above the ground plane to further maximize the emission. Measurements are made with the antenna polarized in both the vertical and the horizontal positions.

5.2. TRANSMITTER ABOVE 1 GHz

RESTRICTED BANDEDGE (LOW CHANNEL)

HORIZONTAL RESULTS

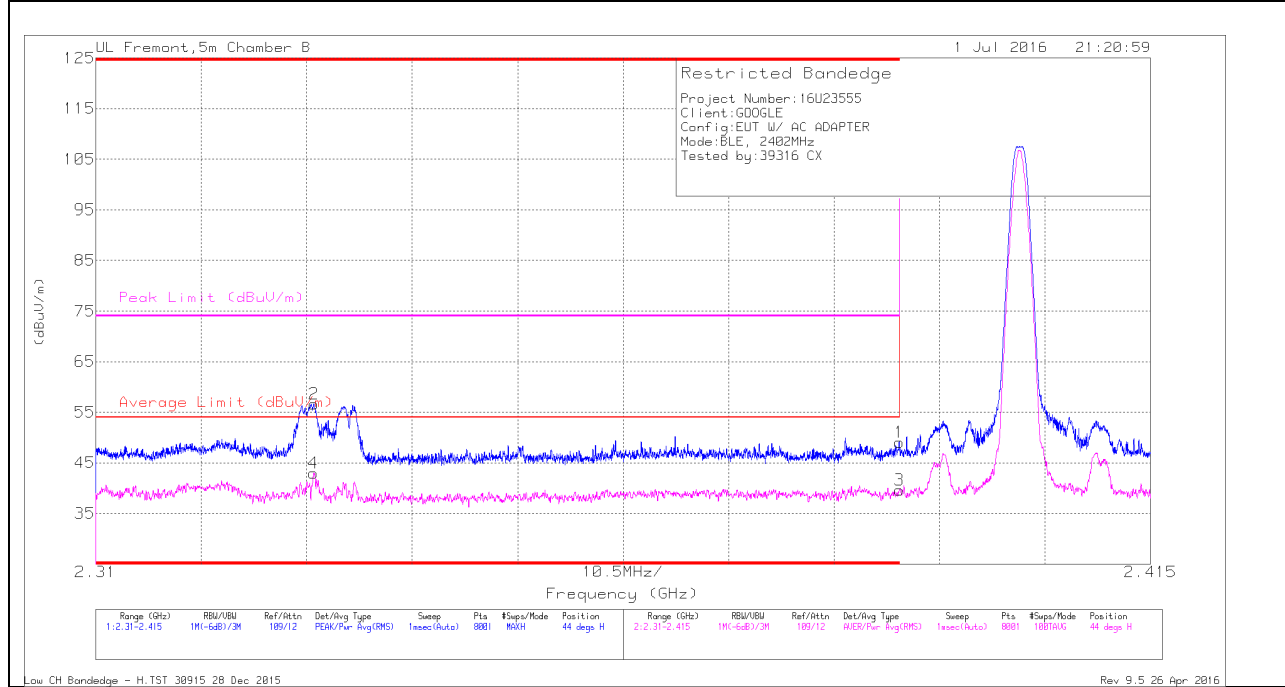

Marker	Frequency (GHz)	Meter Reading (dBuV)	Det	AF T345 (dBm)	Amp/Cbl/Filtr/Pad (dB)	DC Corr (dB)	Corrected Reading (dBuV/m)	Average Limit (dBuV/m)	Margin (dB)	Peak Limit (dBuV/m)	PK Margin (dB)	Azimuth (Degs)	Height (cm)	Polarity
1	* 2.39	39.24	Pk	32.1	-22.3	0	49.04	-	-	74	-24.96	44	133	H
2	* 2.332	47.46	Pk	31.7	-22.5	0	56.66	-	-	74	-17.34	44	133	H
3	* 2.39	27.71	RMS	32.1	-22.3	2.11	39.62	54	-14.38	-	-	44	133	H
4	* 2.332	31.66	RMS	31.7	-22.5	2.11	42.97	54	-11.03	-	-	44	133	H

* - indicates frequency in CFR47 Pt 15 / IC RSS-Restricted Band
 Pk - Peak detector
 RMS - RMS detection

VERTICAL RESULTS

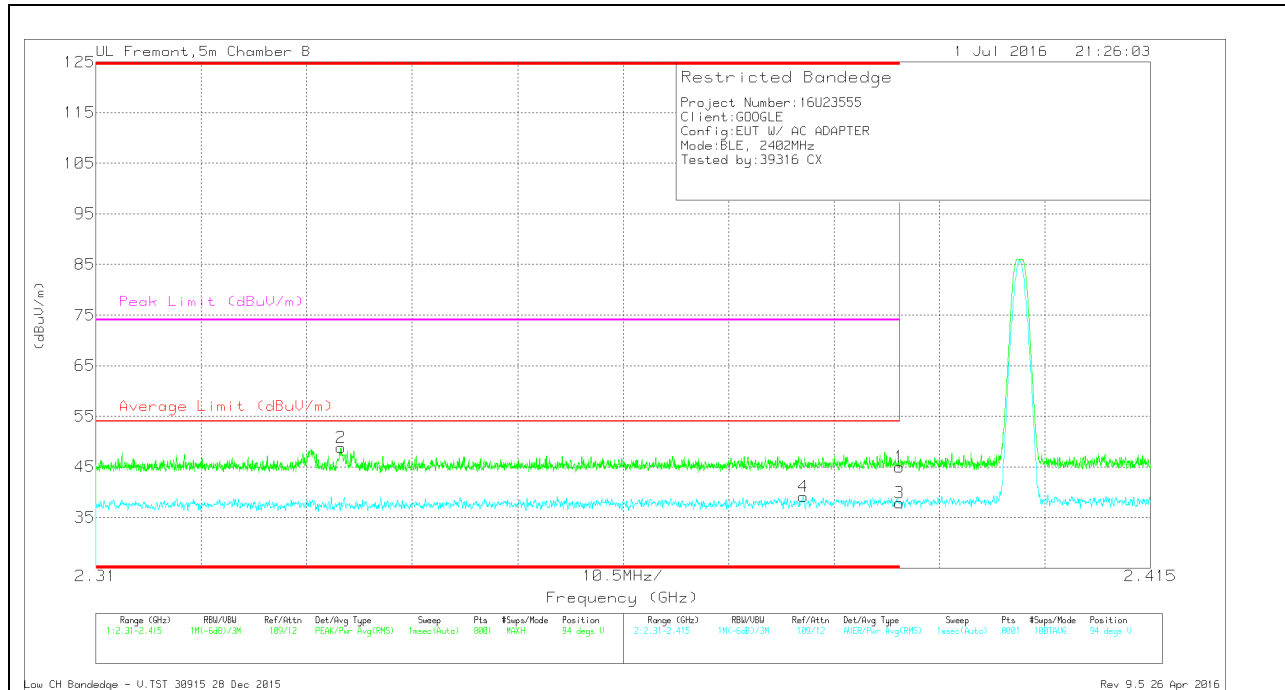

Marker	Frequency (GHz)	Meter Reading (dBuV)	Det	AF T345 (dBm)	Amp/CbI/Ftr/Pad (dB)	DC Corr (dB)	Corrected Reading (dBuV/m)	Average Limit (dBuV/m)	Margin (dB)	Peak Limit (dBuV/m)	PK Margin (dB)	Azimuth (Degs)	Height (cm)	Polarity
2	* 2.334	39.36	Pk	31.7	-22.3	0	48.76	-	-	74	-25.24	94	367	V
4	* 2.38	27.21	RMS	32.1	-22.3	2.11	39.12	54	-14.88	-	-	94	367	V
1	* 2.39	35.21	Pk	32.1	-22.3	0	45.01	-	-	74	-28.99	94	367	V
3	* 2.39	25.95	RMS	32.1	-22.3	2.11	37.86	54	-16.14	-	-	94	367	V

* - indicates frequency in CFR47 Pt 15 / IC RSS-Restricted Band
 Pk - Peak detector
 RMS - RMS detection

AUTHORIZED BANDEDGE (HIGH CHANNEL)

HORIZONTAL RESULTS

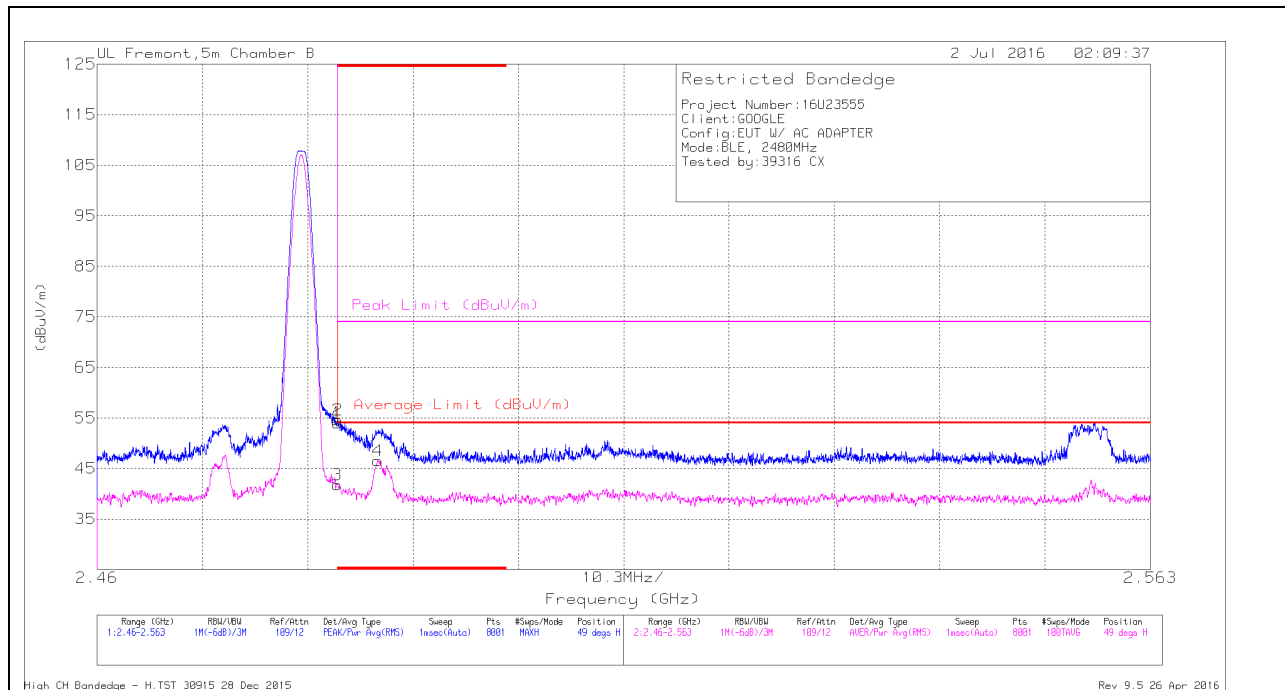

Marker	Frequency (GHz)	Meter Reading (dBuV)	Det	AF T345 (dB/m)	Amp/Cbl/Filt/Pad (dB)	DC Corr (dB)	Corrected Reading (dBuV/m)	Average Limit (dBuV/m)	Margin (dB)	Peak Limit (dBuV/m)	PK Margin (dB)	Azimuth (Degs)	Height (cm)	Polarity
1	* 2.484	44.02	Pk	32.3	-22.3	0	54.02	-	-	74	-19.98	49	168	H
2	* 2.484	44.6	Pk	32.3	-22.3	0	54.6	-	-	74	-19.4	49	168	H
3	* 2.484	29.67	RMS	32.3	-22.3	2.11	41.78	54	-12.22	-	-	49	168	H
4	* 2.487	34.52	RMS	32.3	-22.4	2.11	46.53	54	-7.47	-	-	49	168	H

* - indicates frequency in CFR47 Pt 15 / IC RSS-Restricted Band

Pk - Peak detector

RMS - RMS detection

VERTICAL RESULTS

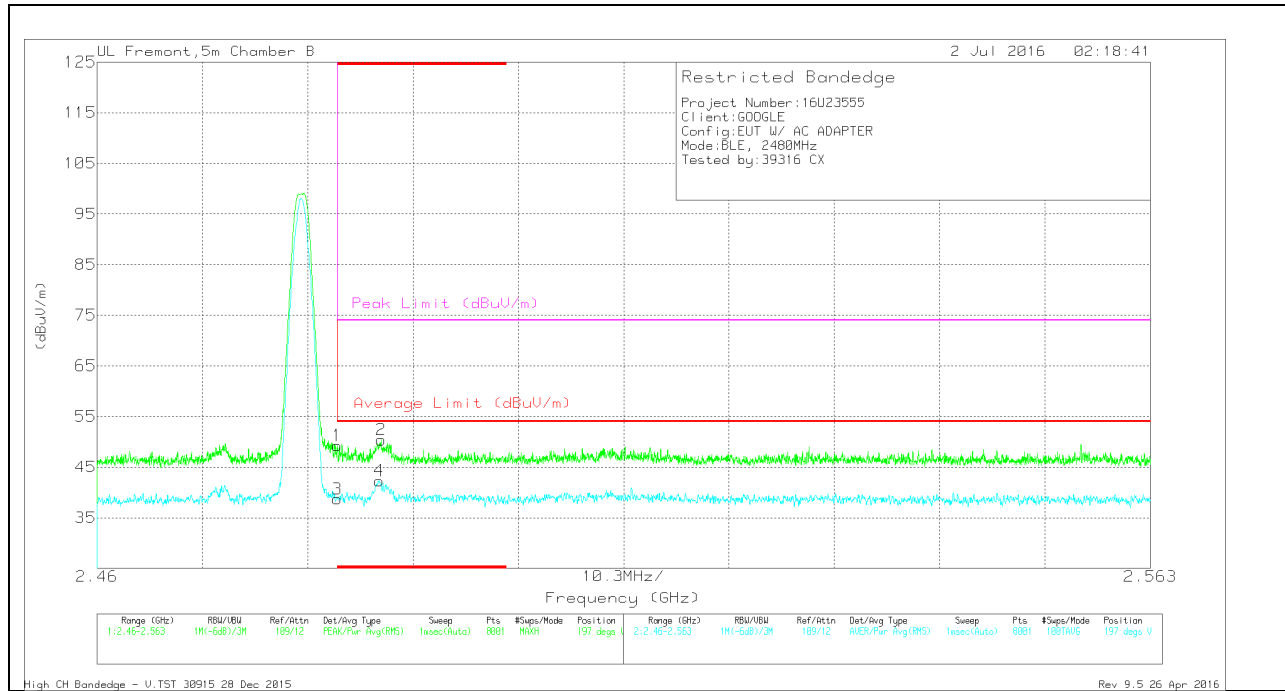

Marker	Frequency (GHz)	Meter Reading (dBuV)	Det	AF T345 (dBm)	Amp/Cbl/Fitr/Pad (dB)	DC Corr (dB)	Corrected Reading (dBuV/m)	Average Limit (dBuV/m)	Margin (dB)	Peak Limit (dBuV/m)	PK Margin (dB)	Azimuth (Degs)	Height (cm)	Polarity
1	* 2.484	39.27	Pk	32.3	-22.3	0	49.27	-	-	74	-24.73	197	386	V
2	* 2.488	40.4	Pk	32.3	-22.3	0	50.4	-	-	74	-23.6	197	386	V
3	* 2.484	26.6	RMS	32.3	-22.3	2.11	38.71	54	-15.29	-	-	197	386	V
4	* 2.488	30.3	RMS	32.3	-22.4	2.11	42.31	54	-11.69	-	-	197	386	V

* - indicates frequency in CFR47 Pt 15 / IC RSS-Restricted Band
 Pk - Peak detector
 RMS - RMS detection

HARMONICS AND SPURIOUS EMISSIONS

LOW CHANNEL RESULTS

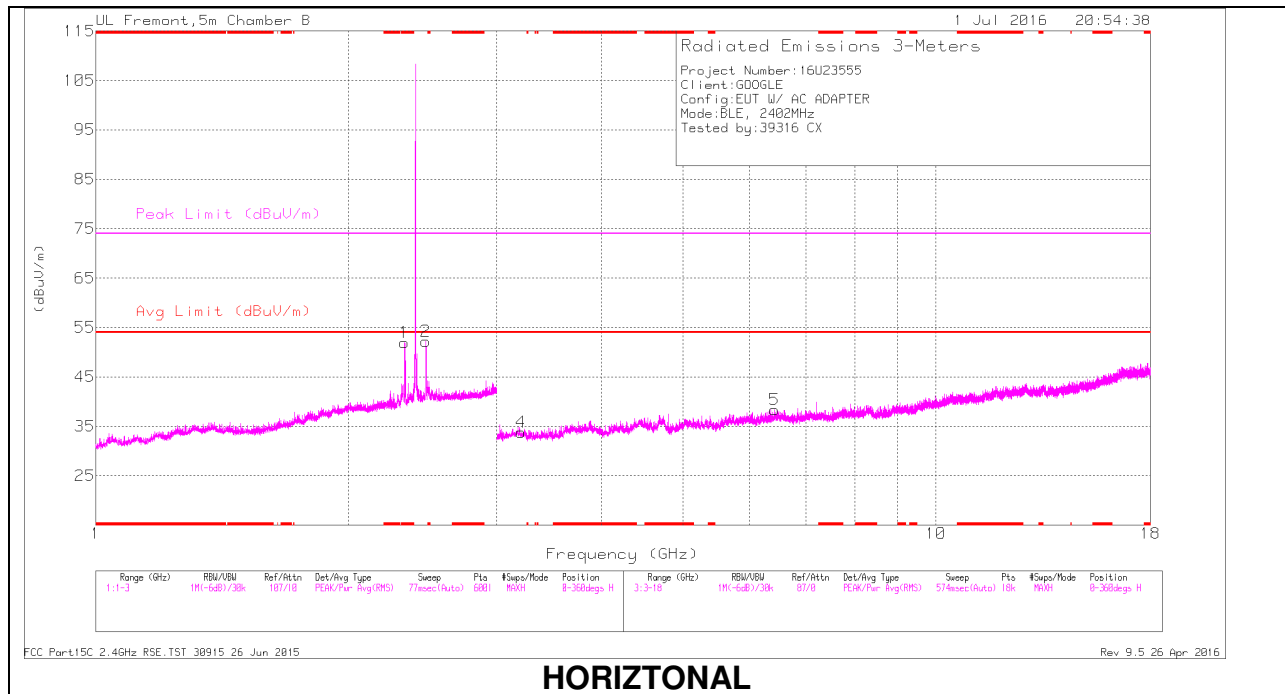

HORIZONTAL

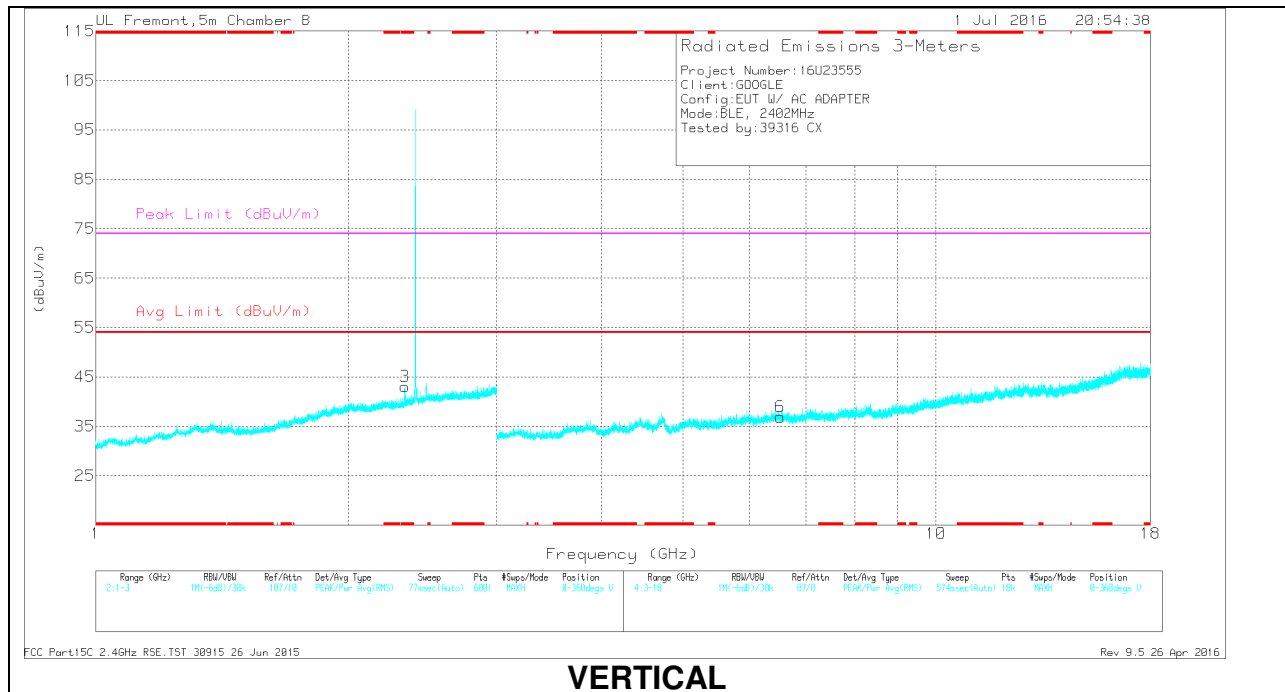

VERTICAL

LOW CHANNEL DATA

Marker	Frequency (GHz)	Meter Reading (dBuV)	Det	AF T345 (dB/m)	Amp/Cbl/Filtr/Pad (dB)	DC Corr (dB)	Corrected Reading (dBuV/m)	Avg Limit (dBuV/m)	Margin (dB)	Peak Limit (dBuV/m)	PK Margin (dB)	Azimuth (Degs)	Height (cm)	Polarity
1	* 2.336	46.82	PK2	31.7	-22.4	0	56.12	-	-	74	-17.88	42	128	H
	* 2.331	32.95	MAv1	31.7	-22.4	2.11	44.36	54	-9.64	-	-	42	128	H
3	* 2.336	42.13	PK2	31.7	-22.4	0	51.43	-	-	74	-22.57	352	354	V
	* 2.331	28.24	MAv1	31.7	-22.4	2.11	39.65	54	-14.35	-	-	352	354	V
2	2.472	42.3	PK	32.3	-22.4	0	52.2	-	-	-	-	0-360	101	H
4	3.21	33.23	PK	33	-32.4	0	33.83	-	-	-	-	0-360	101	H
5	6.427	33.81	PK	35.6	-31	0	38.41	-	-	-	-	0-360	101	H
6	6.521	31.81	PK	35.6	-30.5	0	36.91	-	-	-	-	0-360	101	V

* - indicates frequency in CFR47 Pt 15 / IC RSS-Restricted Band

PK2 - KDB558074 Method: Maximum Peak

MAv1 - KDB558074 Option 1 Maximum RMS Average

MID CHANNEL RESULTS

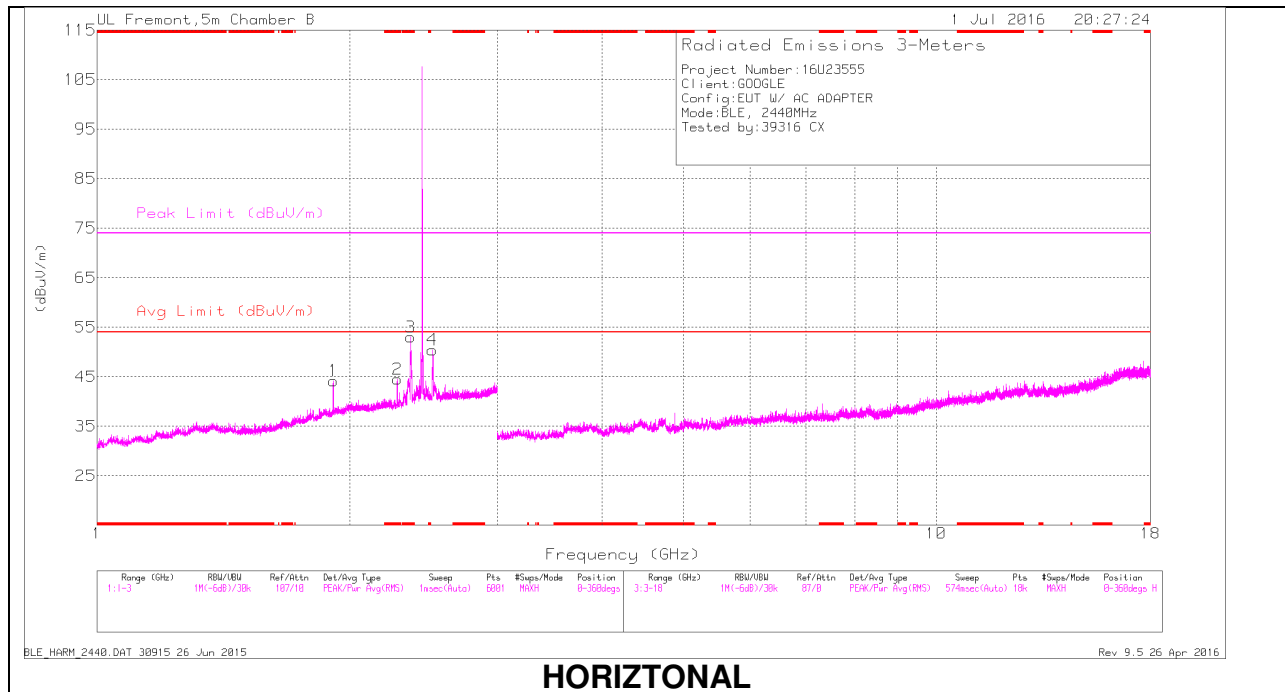

HORIZONTAL

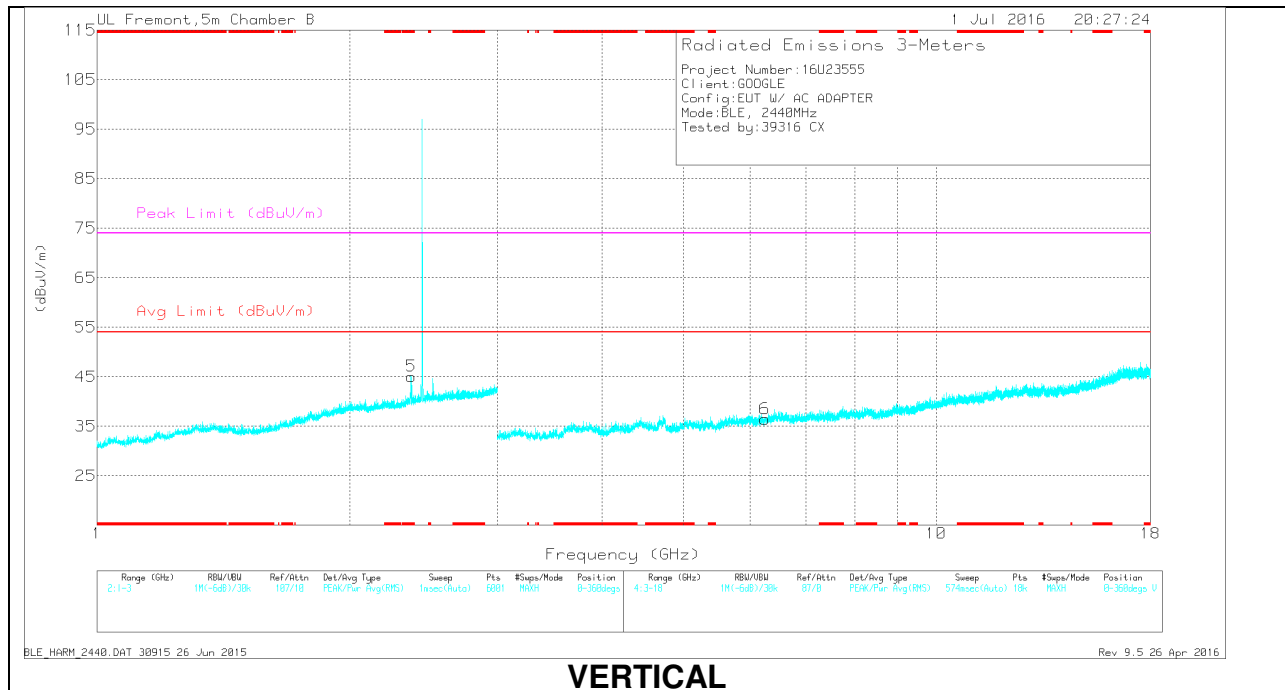

VERTICAL

MID CHANNEL DATA

Marker	Frequency (GHz)	Meter Reading (dBUV)	Det	AF T345 (dB/m)	Amp/Cbl/Filtr/ Pad (dB)	DC Corr (dB)	Corrected Reading (dBUV/m)	Avg Limit (dBUV/m)	Margin (dB)	Peak Limit (dBUV/m)	PK Margin (dB)	Azimuth (Degs)	Height (cm)	Polarity
3	* 2.366	47.61	PK2	32	-22.3	0	57.31	-	-	74	-16.69	53	152	H
	* 2.366	32.63	MAv1	32	-22.3	2.11	44.44	54	-9.56	-	-	53	152	H
2	* 2.283	39.75	PK2	31.5	-22.2	0	49.05	-	-	74	-24.95	26	127	H
	* 2.282	25.95	MAv1	31.5	-22.2	2.11	37.36	54	-16.64	-	-	26	127	H
5	* 2.369	42.74	PK2	32	-22.4	0	52.34	-	-	74	-21.66	358	340	V
	* 2.363	27.55	MAv1	31.9	-22.3	2.11	39.26	54	-14.74	-	-	358	340	V
1	1.914	35.39	PK	30.9	-22.1	0	44.19	-	-	-	-	0-360	101	H
4	2.51	40.44	PK	32.3	-22.3	0	50.44	-	-	-	-	0-360	101	H
6	6.251	32.28	PK	35.5	-31.3	0	36.48	-	-	-	-	0-360	101	V

* - indicates frequency in CFR47 Pt 15 / IC RSS-Restricted Band
 PK2 - KDB558074 Method: Maximum Peak
 MAv1 - KDB558074 Option 1 Maximum RMS Average

HIGH CHANNEL RESULTS

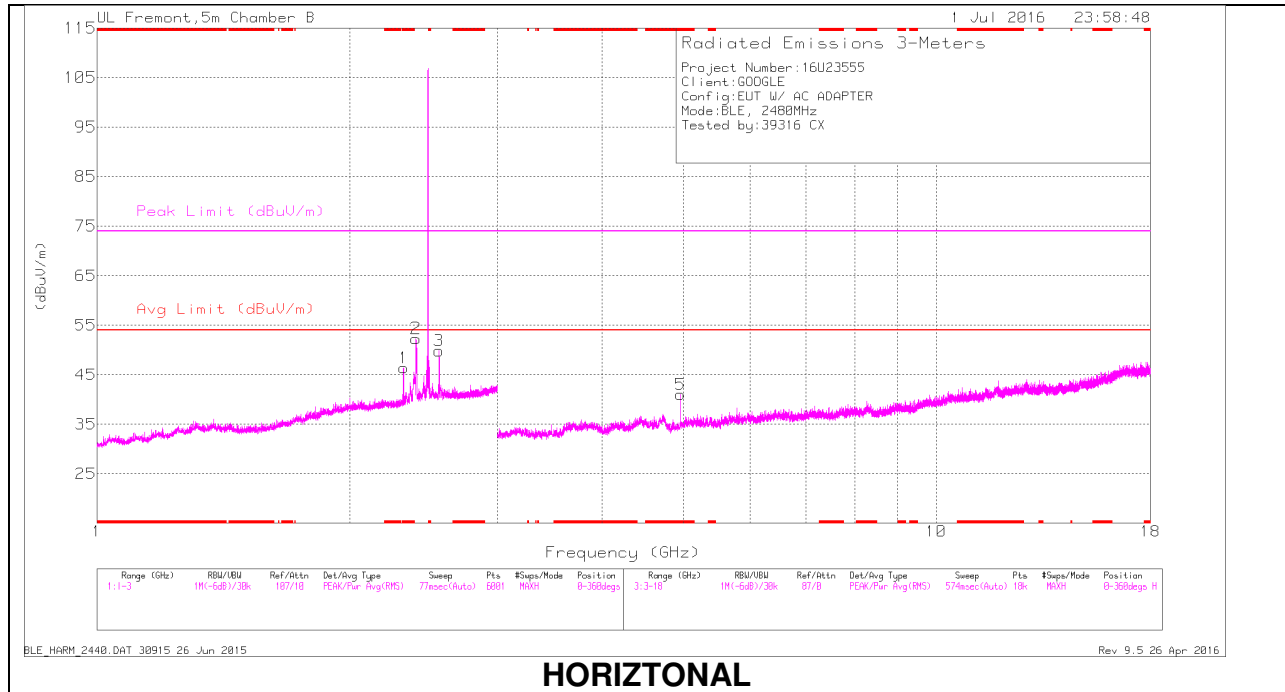

HORIZONTAL

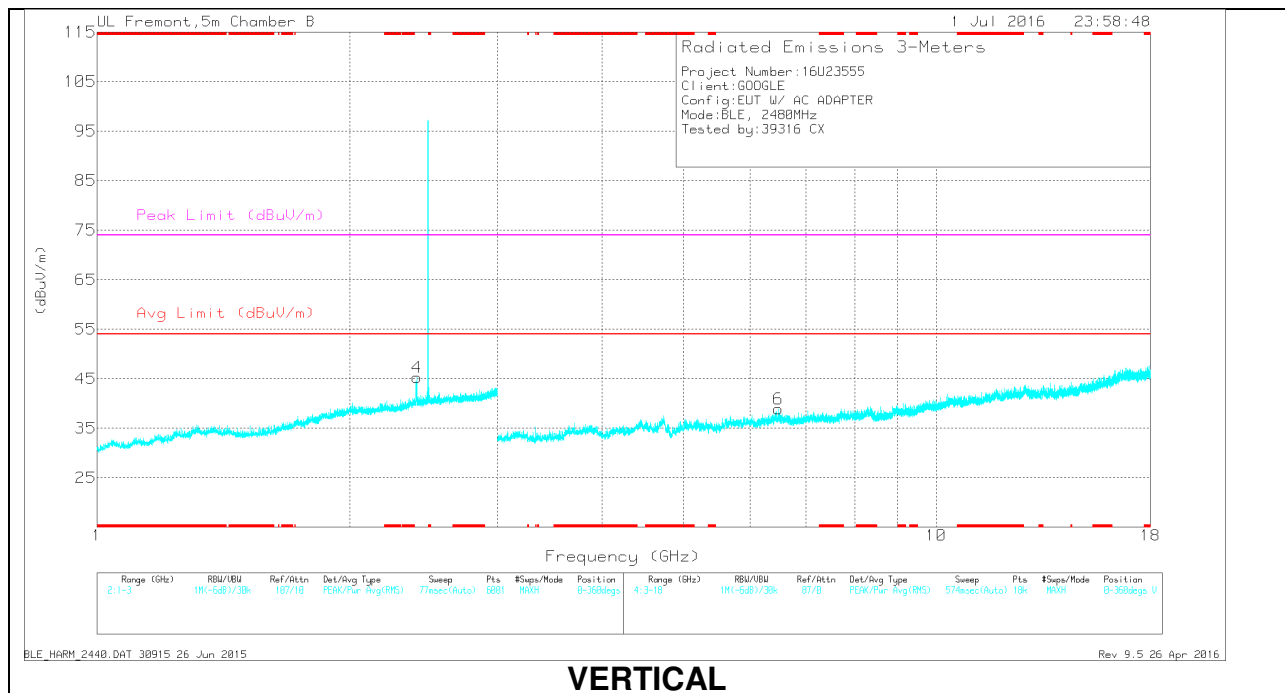

VERTICAL

HIGH CHANNEL DATA

Marker	Frequency (GHz)	Meter Reading (dBuV)	Det	AF T345 (dB/m)	Amp/Cbl/Filtr/P ad (dB)	DC Corr (dB)	Corrected Reading (dBuV/m)	Avg Limit (dBuV/m)	Margin (dB)	Peak Limit (dBuV/m)	PK Margin (dB)	Azimuth (Degs)	Height (cm)	Polarity
1	* 2.321	42.93	PK2	31.6	-22.5	0	52.03	-	-	74	-21.97	43	107	H
	* 2.321	27.65	MAv1	31.6	-22.5	2.11	38.86	54	-15.14	-	-	43	107	H
5	* 4.96	44.41	PK2	34	-32.2	0	46.21	-	-	74	-27.79	115	123	H
	* 4.96	37.2	MAv1	34	-32.2	2.11	41.11	54	-12.89	-	-	115	123	H
2	2.4	42.41	PK	32.2	-22.3	0	52.31	-	-	-	-	0-360	101	H
4	2.406	35.49	PK	32.2	-22.4	0	45.29	-	-	-	-	0-360	101	V
3	2.557	39.75	PK	32.2	-22.1	0	49.85	-	-	-	-	0-360	101	H
6	6.486	33.98	PK	35.6	-30.7	0	38.88	-	-	-	-	0-360	101	V

* - indicates frequency in CFR47 Pt 15 / IC RSS-Restricted Band
 PK2 - KDB558074 Method: Maximum Peak
 MAv1 - KDB558074 Option 1 Maximum RMS Average

5.3. WORST-CASE BELOW 1 GHz

SPURIOUS EMISSIONS 30 TO 1000 MHz (WORST-CASE CONFIGURATION)

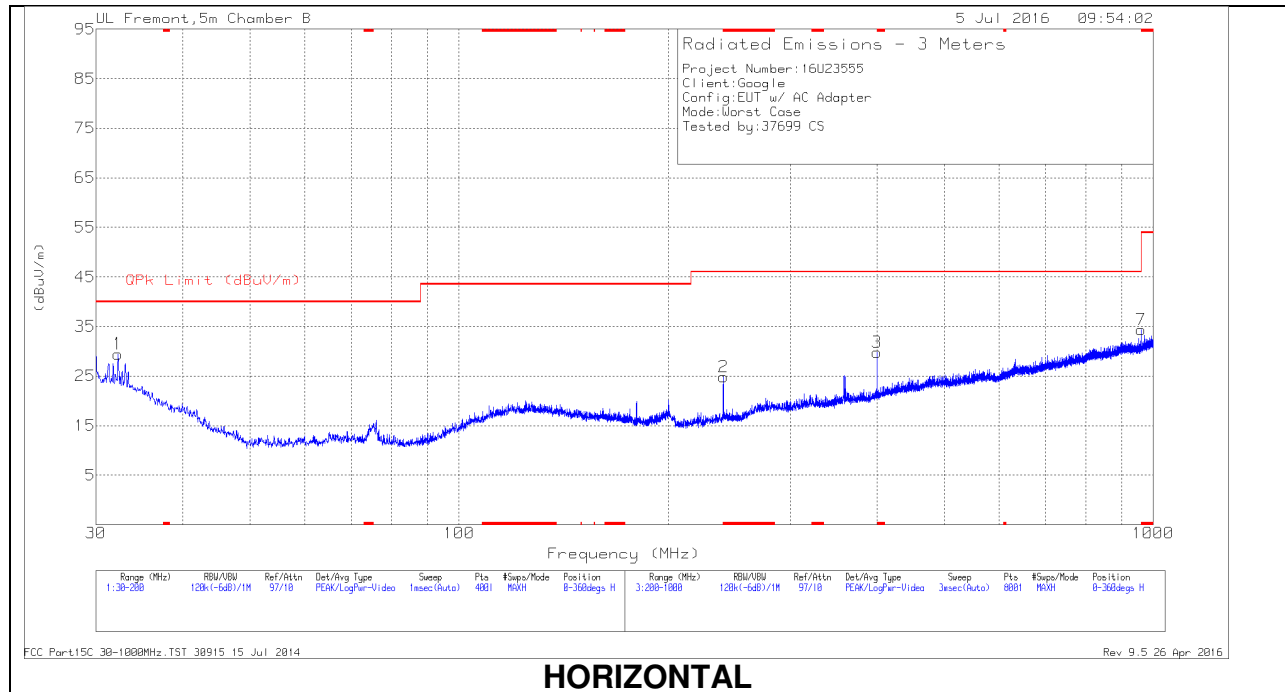

HORIZONTAL

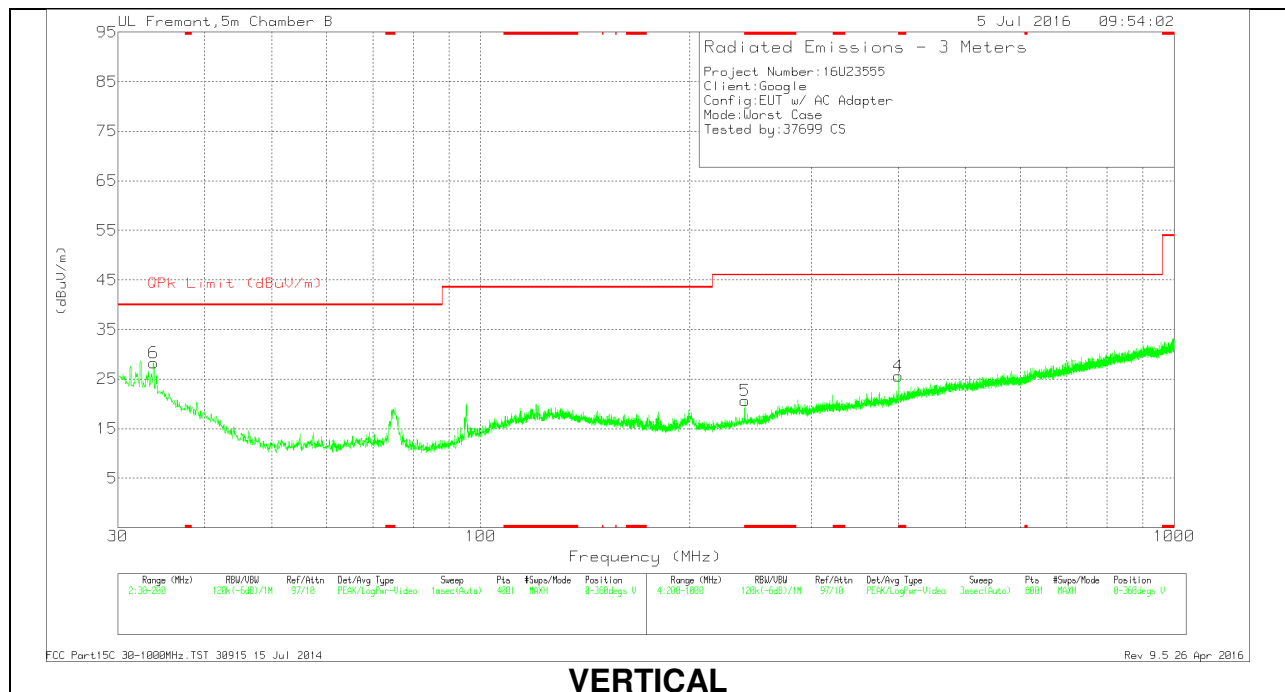

VERTICAL

Data

Marker	Frequency (MHz)	Meter Reading (dBuV)	Det	AF T130 (dB/m)	Amp/Cbl (dB)	Corrected Reading (dBuV/m)	QPk Limit (dBuV/m)	Margin (dB)	Azimuth (Degs)	Height (cm)	Polarity
2	* 240.3	36.01	Pk	15.5	-26.7	24.81	46.02	-21.21	0-360	100	H
3	* 400.3	36.63	Pk	19.5	-26.3	29.83	46.02	-16.19	0-360	100	H
7	* 960.3	31.2	Pk	26.7	-23.5	34.4	53.97	-19.57	0-360	100	H
4	* 400.3	32.41	Pk	19.5	-26.3	25.61	46.02	-20.41	0-360	200	V
5	* 240.3	31.83	Pk	15.5	-26.7	20.63	46.02	-25.39	0-360	200	V
1	32.295	34.77	Pk	23.6	-28.9	29.47	40	-10.53	0-360	100	H
6	33.7825	34.64	Pk	22.5	-28.9	28.24	40	-11.76	0-360	100	V

* - indicates frequency in CFR47 Pt 15 / IC RSS-Restricted Band
 Pk - Peak detector

5.4. WORST-CASE 18 GHz – 26 GHz

SPURIOUS EMISSIONS 18-26 GHz (WORST-CASE CONFIGURATION)

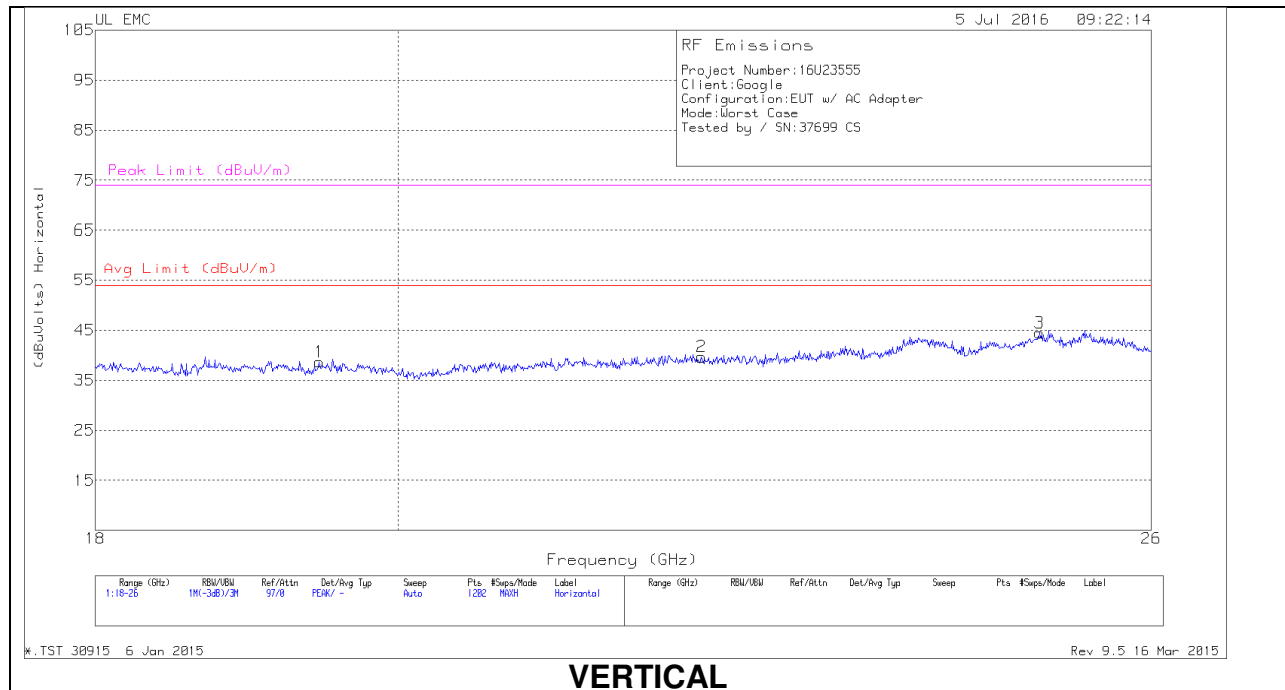
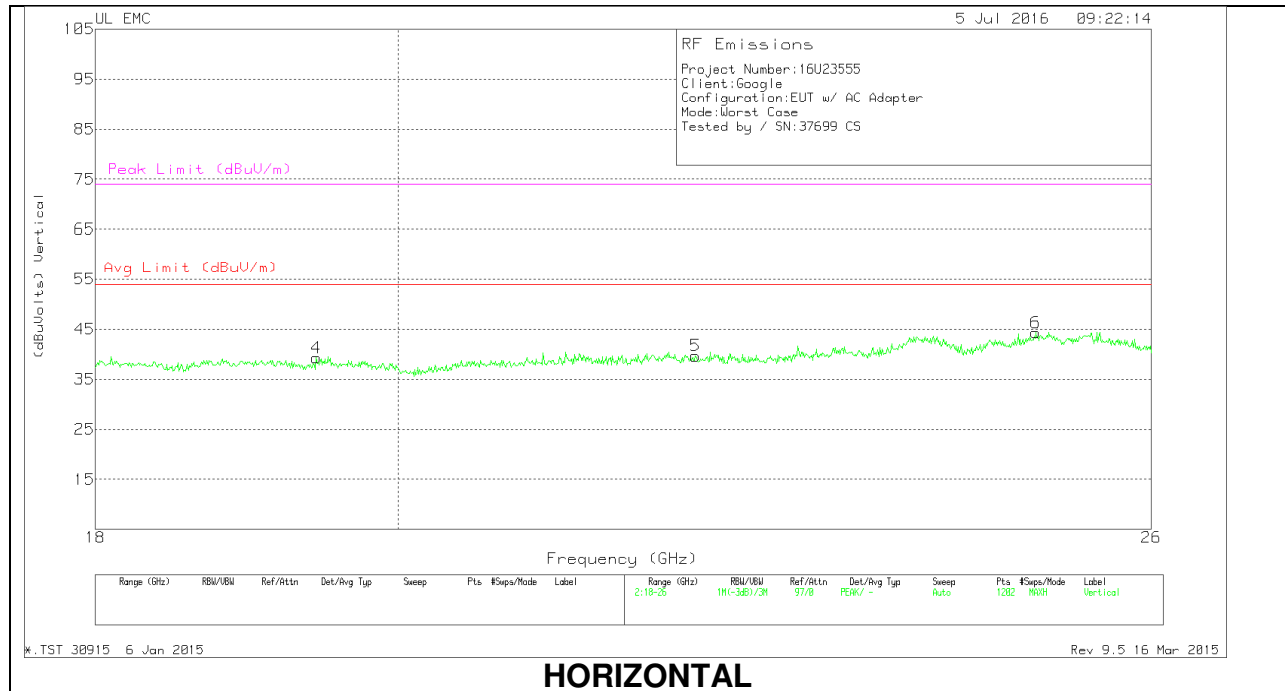

Data

Marker	Frequency (GHz)	Meter Reading (dBuV)	Det	AF T449 (dB/m)	Amp/Cbl (dB)	Dist Corr (dB)	Corrected Reading (dBuV)	Avg Limit (dBuV/m)	Margin (dB)	Peak Limit (dBuV/m)	PK Margin (dB)
1	19.459	40.07	Pk	32.7	-24.6	-9.5	38.67	54	-15.33	74	-35.33
2	22.23	40.27	Pk	33.5	-24.6	-9.5	39.67	54	-14.33	74	-34.33
3	25.007	44.4	Pk	34.2	-24.6	-9.5	44.5	54	-9.5	74	-29.5
4	19.439	40.93	Pk	32.7	-24.8	-9.5	39.33	54	-14.67	74	-34.67
5	22.183	40.57	Pk	33.5	-24.9	-9.5	39.67	54	-14.33	74	-34.33
6	24.974	43.83	Pk	34.2	-24.2	-9.5	44.33	54	-9.67	74	-29.67

Pk - Peak detector

5.5. AC POWER LINE CONDUCTED EMISSIONS

LIMITS

FCC §15.207 (a)

RSS-Gen 8.8

Frequency of Emission (MHz)	Conducted Limit (dBuV)	
	Quasi-peak	Average
0.15-0.5	66 to 56*	56 to 46*
0.5-5	56	46
5-30	60	50

* Decreases with the logarithm of the frequency.

RESULTS

LINE 1 RESULTS

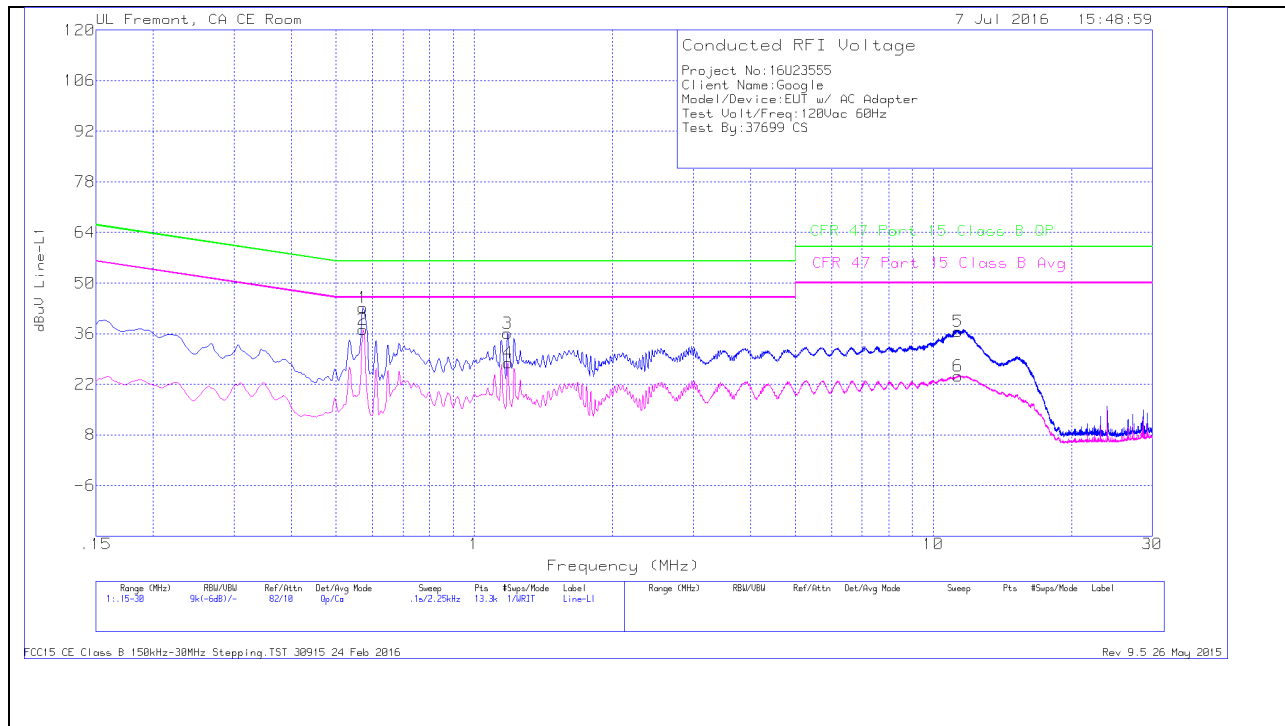

Marker	Frequency (MHz)	Meter Reading (dBuV)	Det	LISN L1	LC Cables 1&3	Limiter (dB)	Corrected Reading (dBuV)	CFR 47 Part 15 Class B QP	QP Margin (dB)	CFR 47 Part 15 Class B Avg	Av(CISPR) Margin (dB)
1	.573	33.16	Qp	0	0	10.1	43.26	56	-12.74	-	-
2	.573	27	Ca	0	0	10.1	37.1	-	-	46	-8.9
3	1.18275	25.85	Qp	0	.1	10.1	36.05	56	-19.95	-	-
4	1.185	17.72	Ca	0	.1	10.1	27.92	-	-	46	-18.08
5	11.33475	26.17	Qp	0	.2	10.2	36.57	60	-23.43	-	-
6	11.328	13.81	Ca	0	.2	10.2	24.21	-	-	50	-25.79

Qp - Quasi-Peak detector
 Ca - CISPR average detection

LINE 2 RESULTS

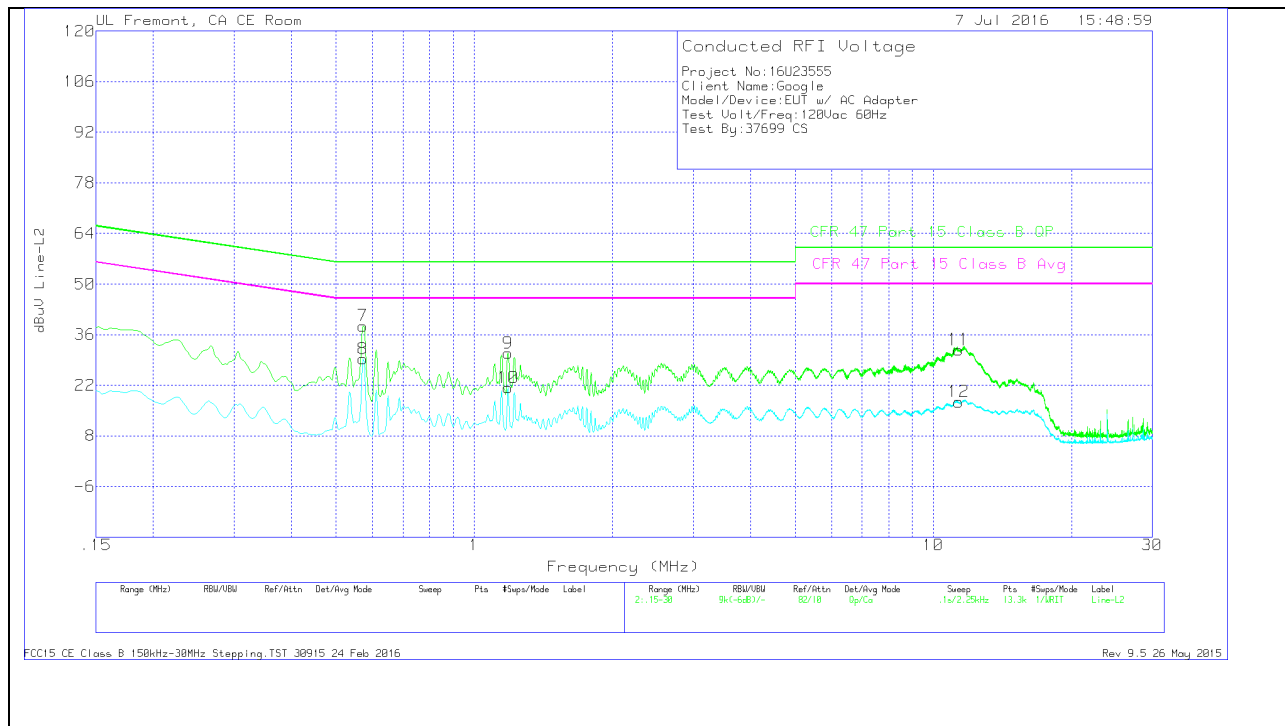

Marker	Frequency (MHz)	Meter Reading (dBuV)	Det	LISN L2	LC Cables 2&3	Limiter (dB)	Corrected Reading (dBuV)	CFR 47 Part 15 Class B QP	QP Margin (dB)	CFR 47 Part 15 Class B Avg	Av(CISPR) Margin (dB)
7	.573	28.34	Qp	0	0	10.1	38.44	56	-17.56	-	-
8	.573	19.26	Ca	0	0	10.1	29.36	-	-	46	-16.64
9	1.185	20.61	Qp	0	.1	10.1	30.81	56	-25.19	-	-
10	1.185	11.04	Ca	0	.1	10.1	21.24	-	-	46	-24.76
11	11.3595	21.43	Qp	0	.2	10.2	31.83	60	-28.17	-	-
12	11.3505	7.01	Ca	0	.2	10.2	17.41	-	-	50	-32.59

Qp - Quasi-Peak detector
 Ca - CISPR average detection