



FCC RADIO TEST REPORT

FCC ID : A4RGZRNL
Equipment : Interactive Media Streaming Device
Model Name : GZRNL
Applicant : Google LLC
1600 Amphitheatre Parkway,
Mountain View, California, 94043 USA
Standard : FCC Part 15 Subpart C §15.247

The product was received on Jan. 30, 2020 and testing was started from Feb. 03, 2020 and completed on Mar. 25, 2020. We, SPORTON INTERNATIONAL INC., EMC & Wireless Communications Laboratory, would like to declare that the tested sample has been evaluated in accordance with the test procedures and has been in compliance with the applicable technical standards.

The report must not be used by the client to claim product certification, approval, or endorsement by TAF or any agency of government.

The test results in this report apply exclusively to the tested model / sample. Without written approval of SPORTON INTERNATIONAL INC. EMC & Wireless Communications Laboratory, the test report shall not be reproduced except in full.

Louis Wu

Approved by: Louis Wu

SPORTON INTERNATIONAL INC. EMC & Wireless Communications Laboratory
No. 52, Huaya 1st Rd., Guishan Dist., Taoyuan City, Taiwan (R.O.C.)



Table of Contents

History of this test report..... 3

Summary of Test Result..... 4

1 General Description 5

 1.1 Product Feature of Equipment Under Test..... 5

 1.2 Product Specification of Equipment Under Test..... 5

 1.3 Modification of EUT 5

 1.4 Testing Location 6

 1.5 Applicable Standards..... 6

2 Test Configuration of Equipment Under Test 7

 2.1 Carrier Frequency and Channel 7

 2.2 Test Mode..... 8

 2.3 Connection Diagram of Test System..... 9

 2.4 Support Unit used in test configuration and system 10

 2.5 EUT Operation Test Setup 10

 2.6 Measurement Results Explanation Example..... 10

3 Test Result 11

 3.1 6dB and 99% Bandwidth Measurement 11

 3.2 Output Power Measurement..... 13

 3.3 Power Spectral Density Measurement 14

 3.4 Conducted Band Edges and Spurious Emission Measurement 16

 3.5 Radiated Band Edges and Spurious Emission Measurement 27

 3.6 AC Conducted Emission Measurement..... 31

 3.7 Antenna Requirements 33

4 List of Measuring Equipment..... 34

5 Uncertainty of Evaluation 36

Appendix A. Conducted Test Results

Appendix B. AC Conducted Emission Test Result

Appendix C. Radiated Spurious Emission

Appendix D. Radiated Spurious Emission Plots

Appendix E. Duty Cycle Plots



Summary of Test Result

Report Clause	Ref Std. Clause	Test Items	Result (PASS/FAIL)	Remark
3.1	15.247(a)(2)	6dB Bandwidth	Pass	-
3.1	2.1049	99% Occupied Bandwidth	Reporting only	-
3.2	15.247(b)	Power Output Measurement	Pass	-
3.3	15.247(e)	Power Spectral Density	Pass	-
3.4	15.247(d)	Conducted Band Edges	Pass	-
		Conducted Spurious Emission	Pass	-
3.5	15.247(d)	Radiated Band Edges and Radiated Spurious Emission	Pass	Under limit 2.04 dB at 2387.595 MHz
3.6	15.207	AC Conducted Emission	Pass	Under limit 4.88 dB at 0.773 MHz
3.7	15.203 & 15.247(b)	Antenna Requirement	Pass	-

Declaration of Conformity:

The test results with all measurement uncertainty excluded are presented in accordance with the regulation limits or requirements declared by manufacturers.

Comments and Explanations:

The declared of product specification for EUT presented in the report are provided by the manufacturer, and the manufacturer takes all the responsibilities for the accuracy of product specification.

Reviewed by: Wii Chang**Report Producer: Lucy Wu**



1 General Description

1.1 Product Feature of Equipment Under Test

Product Feature	
Equipment	Interactive Media Streaming Device
Model Name	GZRNL
FCC ID	A4RGZRNL
EUT supports Radios application	WLAN 11b/g/n HT20 WLAN 11a/n HT20/HT40 WLAN 11ac VHT20/VHT40/VHT80 Bluetooth BR/EDR/LE
EUT Stage	Identical Prototype

Remark: The above EUT's information was declared by manufacturer.

EUT Information List	
S/N	Performed Test Item
WIP01061HFDD0009G	Conducted Measurement
01091HFDD013AA 01091HFDD01587	Radiated Spurious Emission
01161HFDD012HJ	Conducted Emission

1.2 Product Specification of Equipment Under Test

Standards-related Product Specification	
Tx/Rx Channel Frequency Range	2412 MHz ~ 2462 MHz
Maximum (Average) Output Power to antenna	802.11b : 17.70 dBm (0.0589 W) 802.11g : 17.70 dBm (0.0589 W) 802.11n HT20 : 17.70 dBm (0.0589 W)
99% Occupied Bandwidth	802.11b : 10.29MHz 802.11g : 17.28MHz 802.11n HT20 : 18.38MHz
Antenna Type / Gain	PIFA Antenna type with gain 3.02 dBi
Type of Modulation	802.11b : DSSS (DBPSK / DQPSK / CCK) 802.11g/n : OFDM (BPSK / QPSK / 16QAM / 64QAM) 802.11ac : OFDM (BPSK / QPSK / 16QAM / 64QAM / 256QAM)

1.3 Modification of EUT

No modifications are made to the EUT during all test items.



1.4 Testing Location

Test Site	SPORTON INTERNATIONAL INC. EMC & Wireless Communications Laboratory	
Test Site Location	No.52, Huaya 1st Rd., Guishan Dist., Taoyuan City, Taiwan (R.O.C.) TEL: +886-3-327-3456 FAX: +886-3-328-4978	
Test Site No.	Sporton Site No.	
	TH05-HY	CO05-HY

Note: The test site complies with ANSI C63.4 2014 requirement.

Test Site	SPORTON INTERNATIONAL INC. EMC & Wireless Communications Laboratory	
Test Site Location	No.58, Aly. 75, Ln. 564, Wenhua 3rd, Rd., Guishan Dist., Taoyuan City, Taiwan (R.O.C.) TEL: +886-3-327-0868 FAX: +886-3-327-0855	
Test Site No.	Sporton Site No.	
	03CH12-HY	

Note: The test site complies with ANSI C63.4 2014 requirement.

FCC designation No.: TW1190 and TW0007

1.5 Applicable Standards

According to the specifications of the manufacturer, the EUT must comply with the requirements of the following standards:

- ♦ FCC Part 15 Subpart C §15.247
- ♦ FCC KDB Publication No. 558074 D01 DTS Meas. Guidance v05r02
- ♦ FCC KDB 414788 D01 Radiated Test Site v01r01.
- ♦ ANSI C63.10-2013

Remark: All test items were verified and recorded according to the standards and without any deviation during the test.



2 Test Configuration of Equipment Under Test

- a. The EUT has been associated with peripherals and configuration operated in a manner tended to maximize its emission characteristics in a typical application. Frequency range investigated: conduction emission (150 kHz to 30 MHz), radiation emission (9 kHz to the 10th harmonic of the highest fundamental frequency or to 40 GHz, whichever is lower). For radiated measurement, pre-scanned in three orthogonal panels, X, Y, Z. The worst cases (Z plane) were recorded in this report.

- b. AC power line Conducted Emission was tested under maximum output power.

2.1 Carrier Frequency and Channel

Frequency Band	Channel	Freq. (MHz)	Channel	Freq. (MHz)
2400-2483.5 MHz	1	2412	7	2442
	2	2417	8	2447
	3	2422	9	2452
	4	2427	10	2457
	5	2432	11	2462
	6	2437		



2.2 Test Mode

Final test modes are considering the modulation and worse data rates as below table.

Modulation	Data Rate
802.11b	1 Mbps
802.11g	6 Mbps
802.11n HT20	MCS0

Test Cases	
AC Conducted Emission	Mode 1: Bluetooth Link Controller + WLAN (2.4GHz) Link + H-Pattern + USB Cable 1 (Charging from AC Adapter)
Remark: For Radiated Test Cases, the tests were performed with AC Adapter 1.	

Ch. #	2400-2483.5 MHz		
	802.11b	802.11g	802.11n HT20
Low	01	01	01
Middle	06	06	06
High	11	11	10
			11

Remark: For radiation spurious emission, the final modulation and the worst data rate was reference the max RF conducted power.

2.3 Connection Diagram of Test System

<AC Conducted Emission Mode>

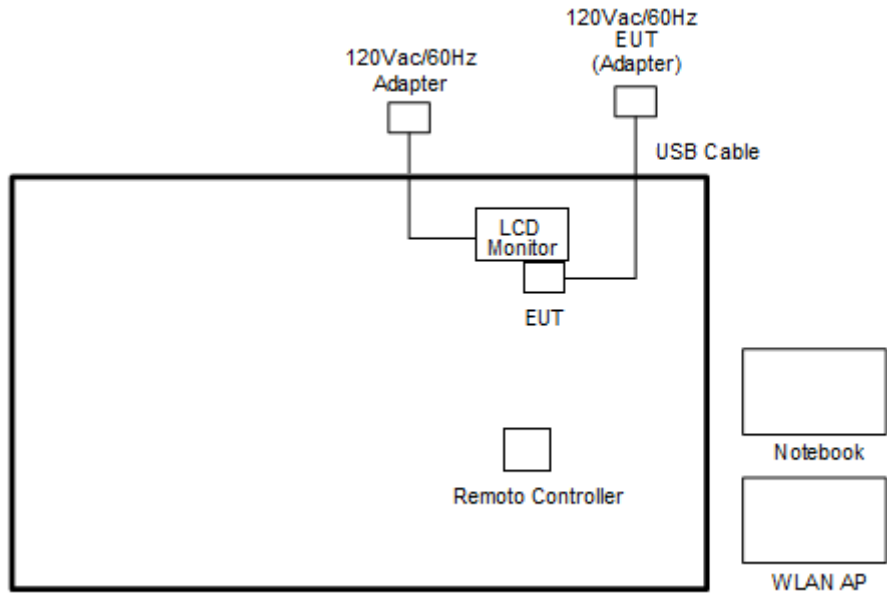

<WLAN TX Mode>

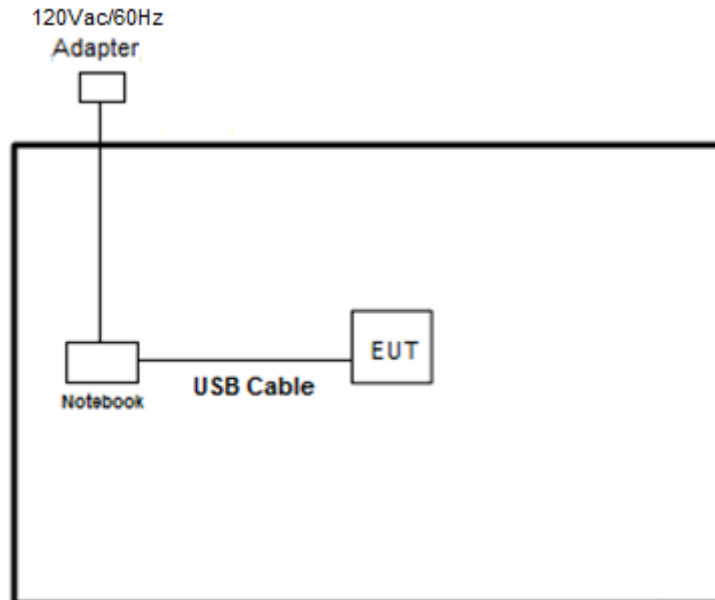



2.4 Support Unit used in test configuration and system

Item	Equipment	Trade Name	Model Name	FCC ID	Data Cable	Power Cord
1.	WLAN AP	ASUS	RT-AC66U	MSQ-RTAC66U	N/A	Unshielded, 1.8 m
2.	Notebook	DELL	Latitude 3400	FCC DoC	N/A	AC I/P: Unshielded, 1.2 m DC O/P: Shielded, 1.8 m
3.	LCD Monitor	DELL	P2715QT	FCC DoC	Shielded, 1.6 m	Unshielded, 1.8 m
4.	Remote control	Google	AEVM1-RCX1	N/A	N/A	N/A

2.5 EUT Operation Test Setup

The RF test items, utility “CMD” was installed in Notebook which was programmed in order to make the EUT get into the engineering modes to provide channel selection, power level, data rate and the application type and for continuous transmitting signals.

2.6 Measurement Results Explanation Example

For all conducted test items:

The offset level is set in the spectrum analyzer to compensate the RF cable loss and attenuator factor between EUT conducted output port and spectrum analyzer. With the offset compensation, the spectrum analyzer reading level is exactly the EUT RF output level.

Example:

The spectrum analyzer offset is derived from RF cable loss and attenuator factor.

Offset = RF cable loss + attenuator factor.

Following shows an offset computation example with cable loss 4.2 dB and 10dB attenuator.

$$\begin{aligned} \text{Offset(dB)} &= \text{RF cable loss(dB)} + \text{attenuator factor(dB)}. \\ &= 4.2 + 10 = 14.2 \text{ (dB)} \end{aligned}$$

3 Test Result

3.1 6dB and 99% Bandwidth Measurement

3.1.1 Limit of 6dB and 99% Bandwidth

The minimum 6 dB bandwidth shall be at least 500 kHz.

3.1.2 Measuring Instruments

See list of measuring equipment of this test report.

3.1.3 Test Procedures

1. The testing follows the ANSI C63.10 Section 6.9.3 (OBW) and 11.8.1 (6dB BW).
2. The RF output of EUT was connected to the spectrum analyzer by RF cable and attenuator. The path loss was compensated to the results for each measurement.
3. Set to the maximum power setting and enable the EUT transmit continuously.
4. Make the measurement with the spectrum analyzer's resolution bandwidth (RBW) = 100 kHz. Set the Video bandwidth (VBW) = 300 kHz. In order to make an accurate measurement. The 6 dB bandwidth must be greater than 500 kHz.
5. For 99% Bandwidth Measurement, the spectrum analyzer's resolution bandwidth (RBW) is set 1-5% of the emission bandwidth and set the Video bandwidth (VBW) $\geq 3 * RBW$.
6. Measure and record the results in the test report.

3.1.4 Test Setup





3.1.5 Test Result of 6dB and 99% Occupied Bandwidth

Please refer to Appendix A.

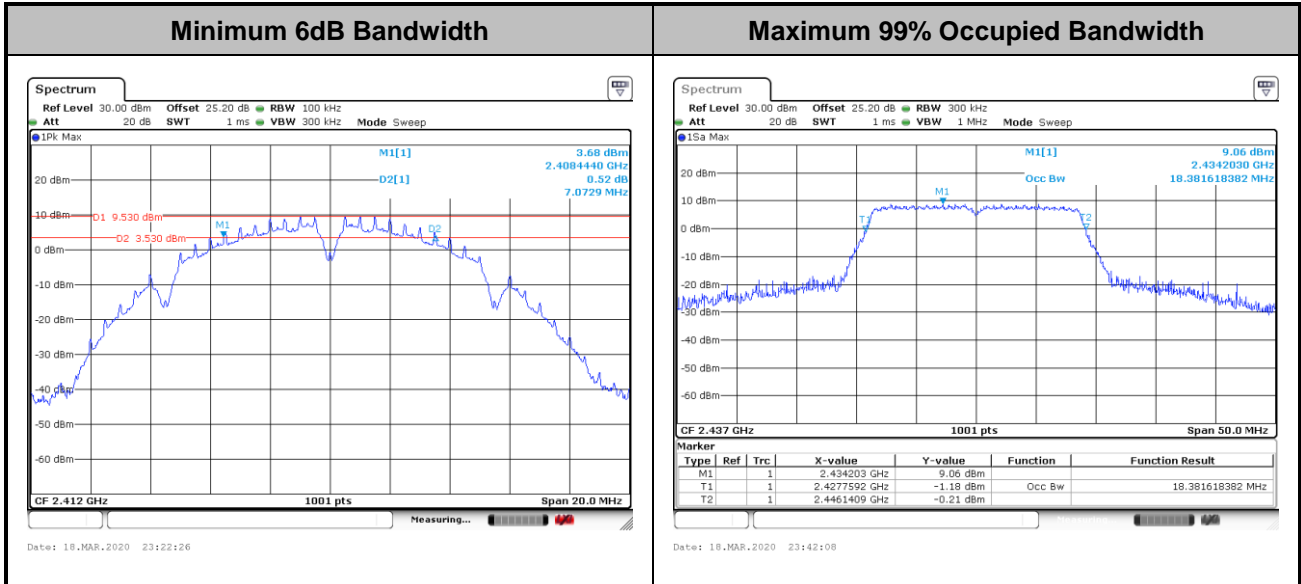

Note: The occupied channel bandwidth is maintained within the band of operation for all of the modulations.

3.2 Output Power Measurement

3.2.1 Limit of Output Power

For systems using digital modulation in the 2400-2483.5MHz, the limit for average output power is 30dBm. If transmitting antenna with directional gain greater than 6dBi is used, the average output power from the intentional radiator shall be reduced below the above stated value by the amount in dB that the directional gain of the antenna exceeds 6 dBi. In case of point-to-point operation, the limit has to be reduced by 1dB for every 3dB that the directional gain of the antenna exceeds 6dBi.

3.2.2 Measuring Instruments

See list of measuring equipment of this test report.

3.2.3 Test Procedures

1. For Average Power, the testing follows ANSI C63.10 Section 11.9.2.3.2 Method AVGPM-G
2. The RF output of EUT was connected to the power meter by RF cable and attenuator. The path loss was compensated to the results for each measurement.
3. Set to the maximum power setting and enable the EUT transmit continuously.
4. Measure the conducted output power and record the results in the test report.

3.2.4 Test Setup

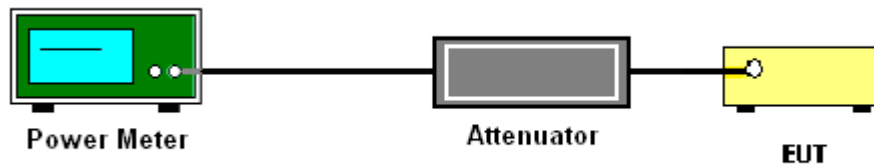

3.2.5 Test Result of Average Output Power

Please refer to Appendix A.

3.3 Power Spectral Density Measurement

3.3.1 Limit of Power Spectral Density

The peak power spectral density shall not be greater than 8dBm in any 3kHz band at any time interval of continuous transmission.

3.3.2 Measuring Instruments

See list of measuring equipment of this test report.

3.3.3 Test Procedures

1. The testing follows the ANSI C63.10 Section 11.10.2 Method PKPSD.
2. The RF output of EUT was connected to the spectrum analyzer by RF cable and attenuator. The path loss was compensated to the results for each measurement.
3. Set to the maximum power setting and enable the EUT transmit continuously.
4. Make the measurement with the spectrum analyzer's resolution bandwidth (RBW) = 3 kHz. Video bandwidth VBW = 10 kHz In order to make an accurate measurement, set the span to 1.5 times DTS Channel Bandwidth. (6dB BW)
5. Detector = peak, Sweep time = auto couple, Trace mode = max hold, Allow trace to fully stabilize. Use the peak marker function to determine the maximum power level.
6. Measure and record the results in the test report.

3.3.4 Test Setup

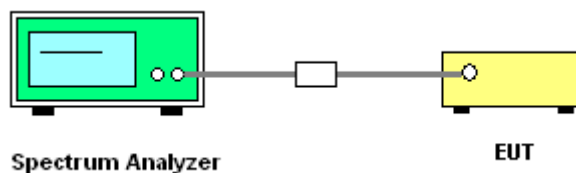



3.3.5 Test Result of Power Spectral Density

Please refer to Appendix A.

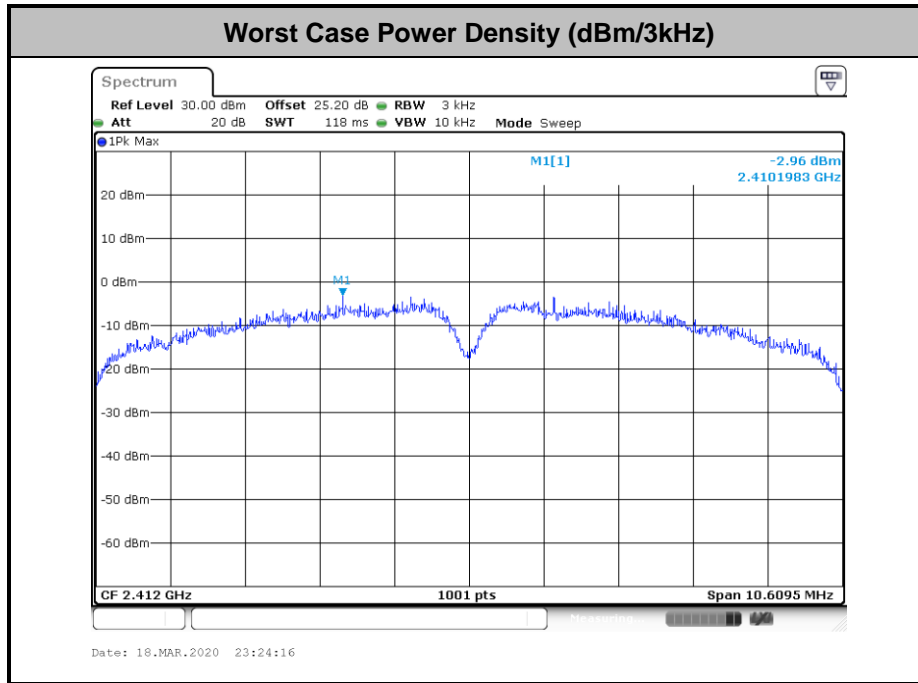

3.4 Conducted Band Edges and Spurious Emission Measurement

3.4.1 Limit of Conducted Band Edges and Spurious Emission Measurement

In any 100 kHz bandwidth outside of the authorized frequency band, the emissions which fall in the non-restricted bands shall be attenuated at least 20 dB / 30dB relative to the maximum PSD level in 100 kHz by RF conducted measurement.

3.4.2 Measuring Instruments

See list of measuring equipment of this test report.

3.4.3 Test Procedures

1. The testing follows the ANSI C63.10 Section 11.11.3 Emission level measurement.
2. The RF output of EUT was connected to the spectrum analyzer by RF cable and attenuator. The path loss was compensated to the results for each measurement.
3. Set to the maximum power setting and enable the EUT transmit continuously.
4. Set RBW = 100 kHz, VBW=300 kHz, Peak Detector. Unwanted Emissions measured in any 100 kHz bandwidth outside of the authorized frequency band shall be attenuated by at least 30 dB relative to the maximum in-band peak PSD level in 100 kHz when maximum peak conducted output power procedure is used. If the transmitter complies with the conducted power limits based on the use of RMS averaging over a time interval, the attenuation required under this paragraph shall be 30 dB instead of 20 dB per 15.247(d).
5. Measure and record the results in the test report.
6. The RF fundamental frequency should be excluded against the limit line in the operating frequency band.

3.4.4 Test Setup

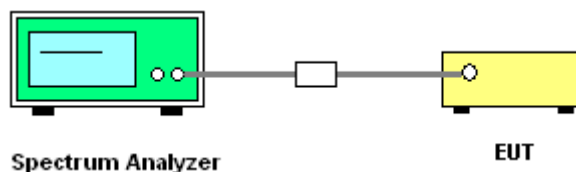



3.4.5 Test Result of Conducted Band Edges and Spurious Emission

Test Engineer :	Kathy Chen and Derek Hsu	Temperature :	21~25°C
		Relative Humidity :	51~54%

Number of TX = 1, Ant. 1 (Measured)

Test Mode :	802.11b	Test Channel :	01
-------------	---------	----------------	----

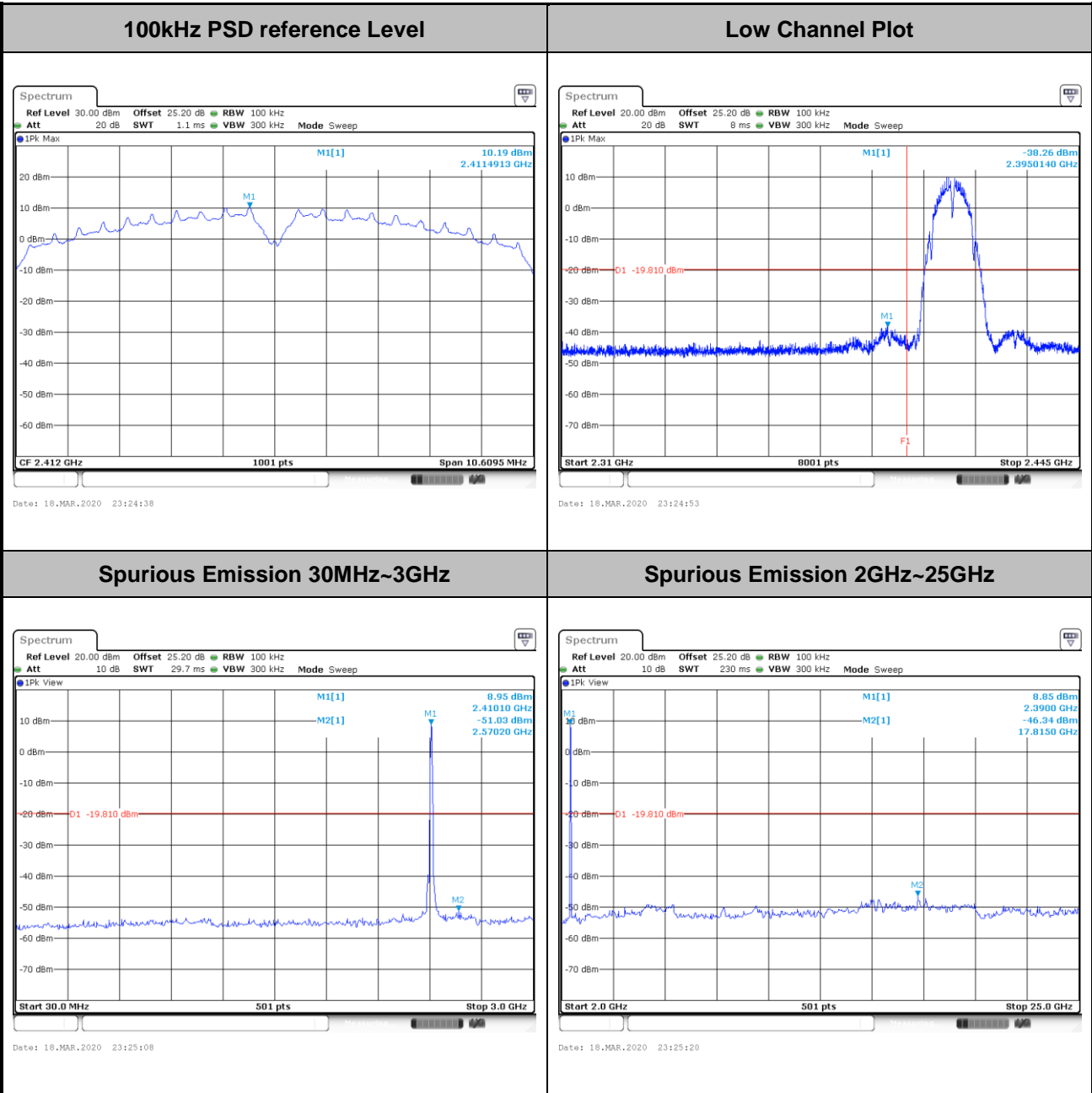



Test Mode :	802.11b	Test Channel :	06
-------------	---------	----------------	----

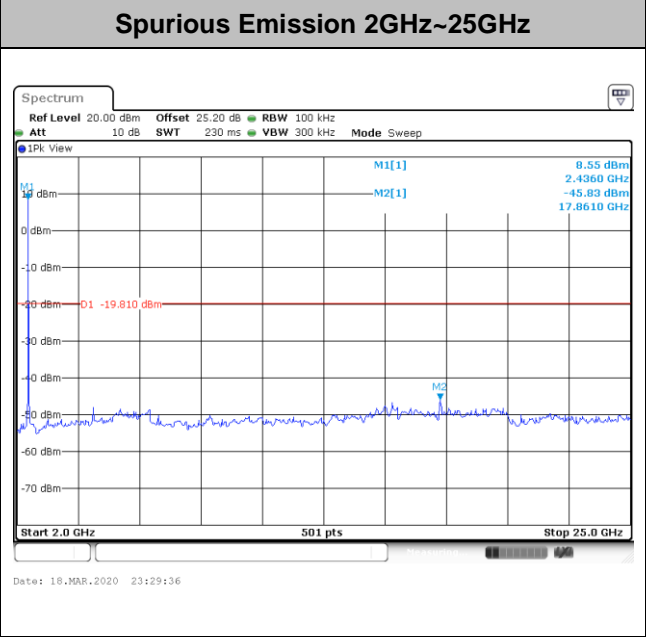
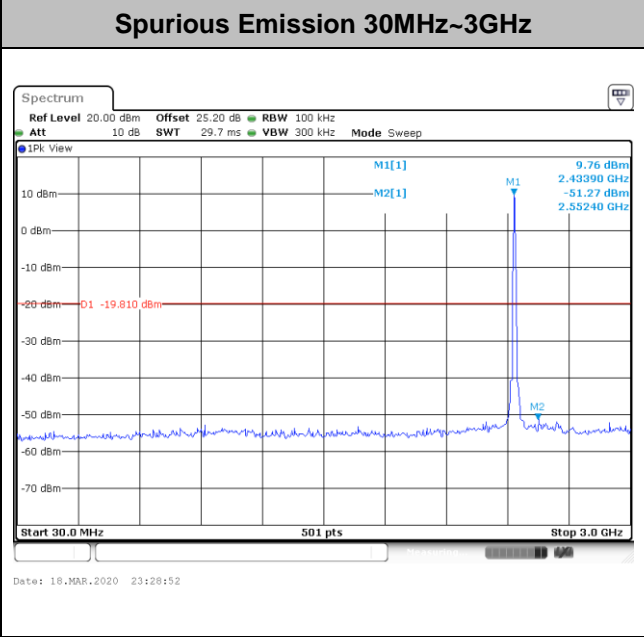
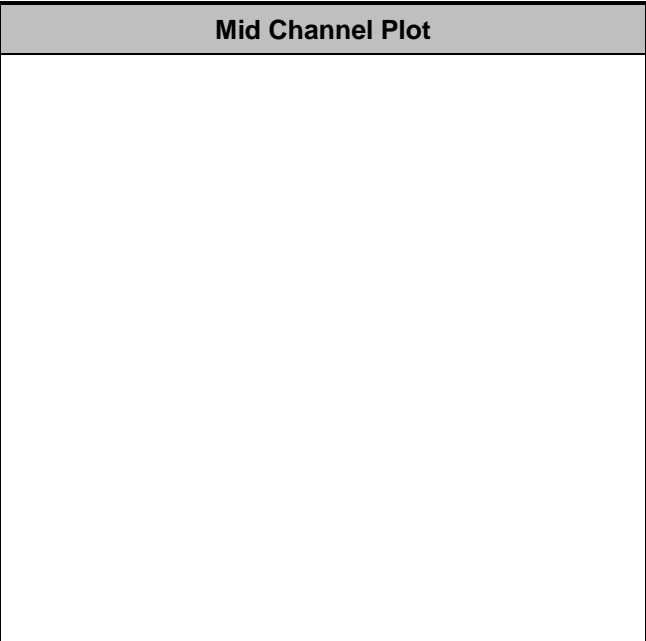
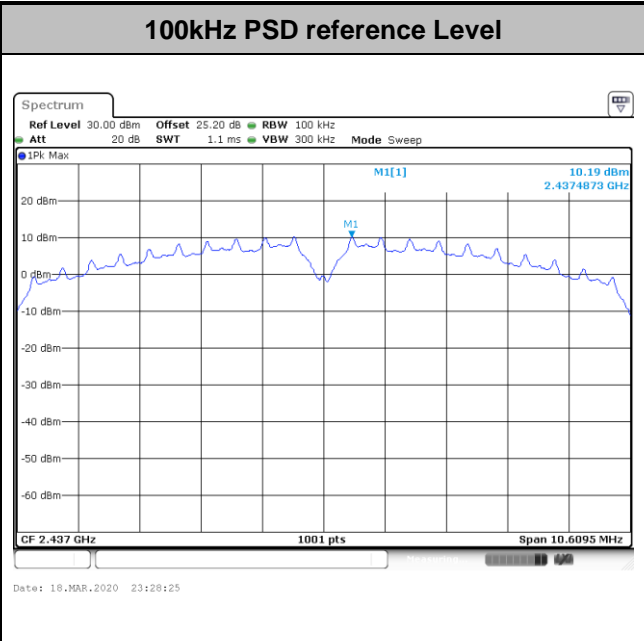



Test Mode :	802.11b	Test Channel :	11
-------------	---------	----------------	----

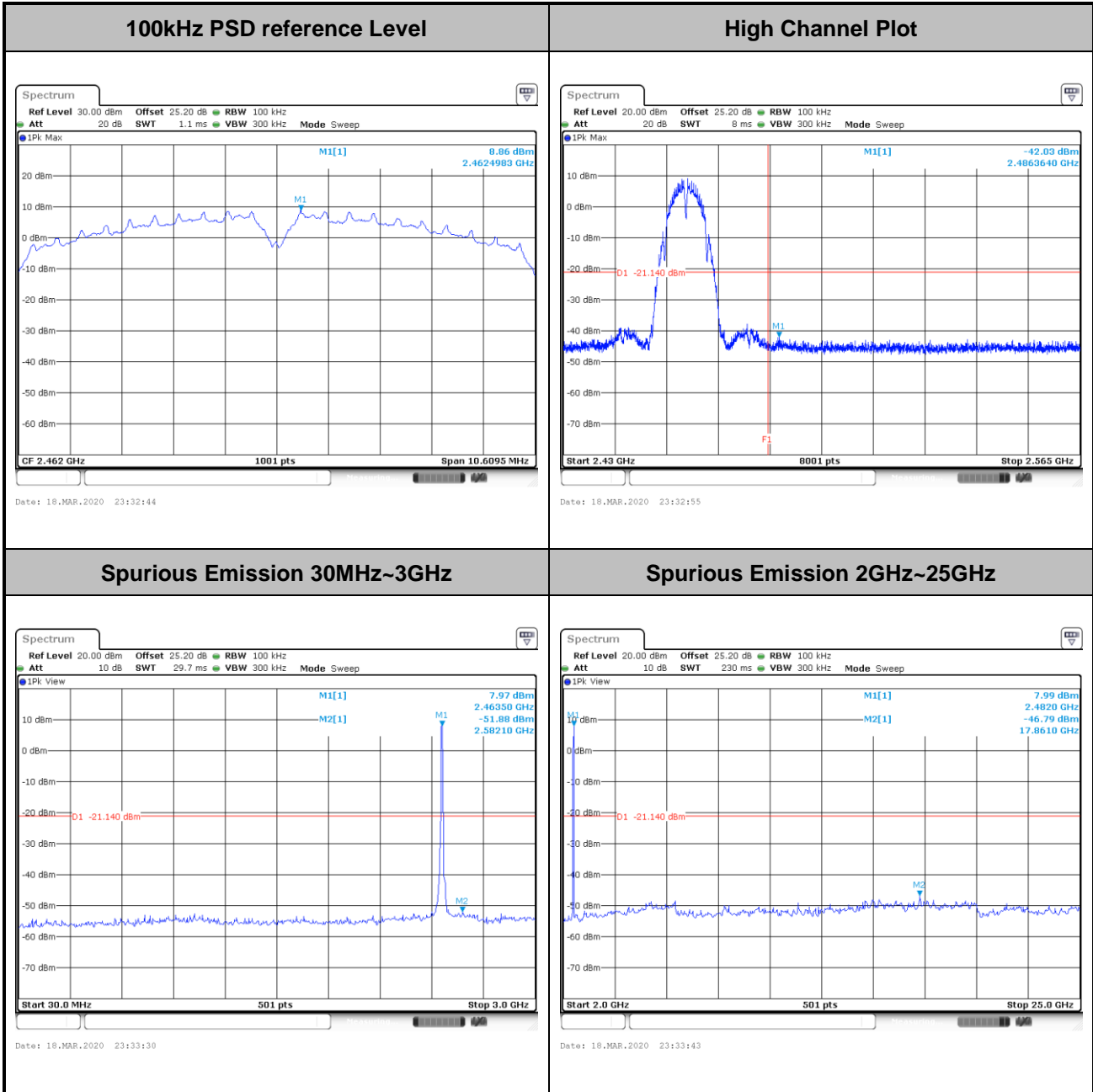



Test Mode :	802.11g	Test Channel :	01
-------------	---------	----------------	----

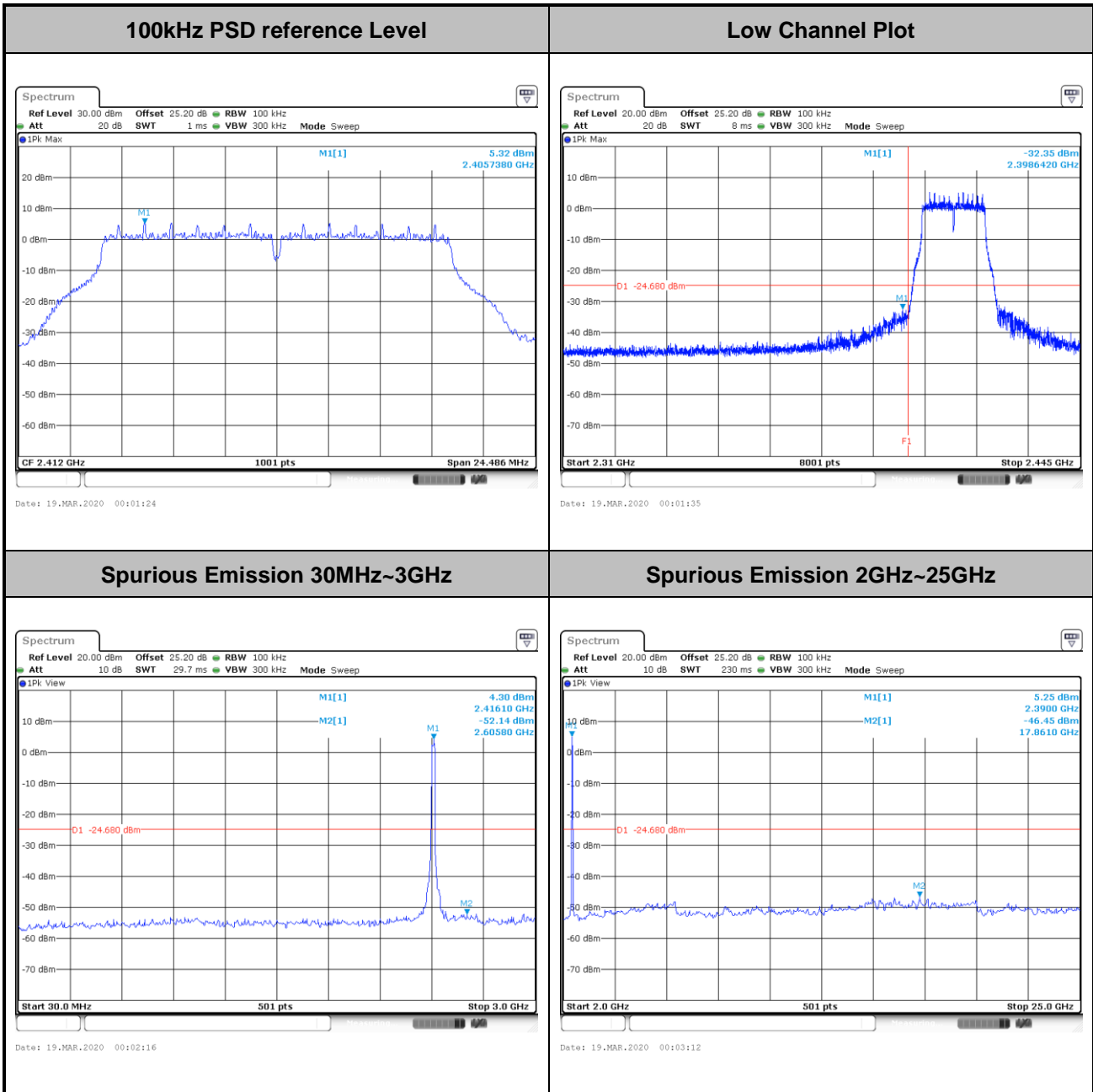



Test Mode :	802.11g	Test Channel :	06
-------------	---------	----------------	----

100kHz PSD reference Level	Mid Channel Plot
-----------------------------------	-------------------------

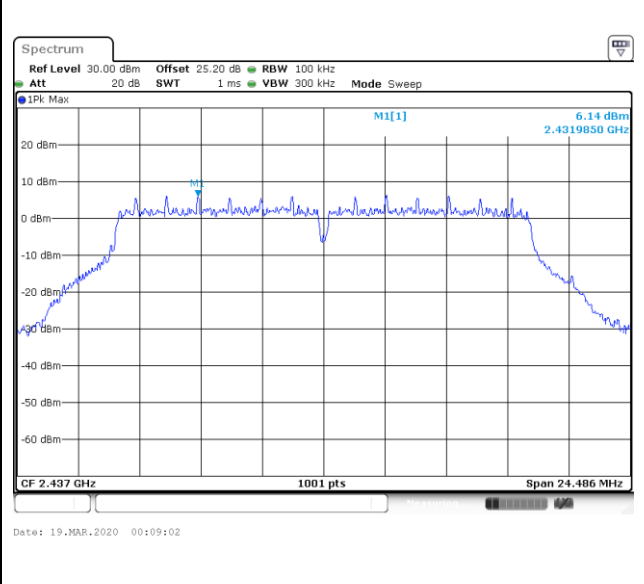

Spurious Emission 30MHz~3GHz	Spurious Emission 2GHz~25GHz
-------------------------------------	-------------------------------------

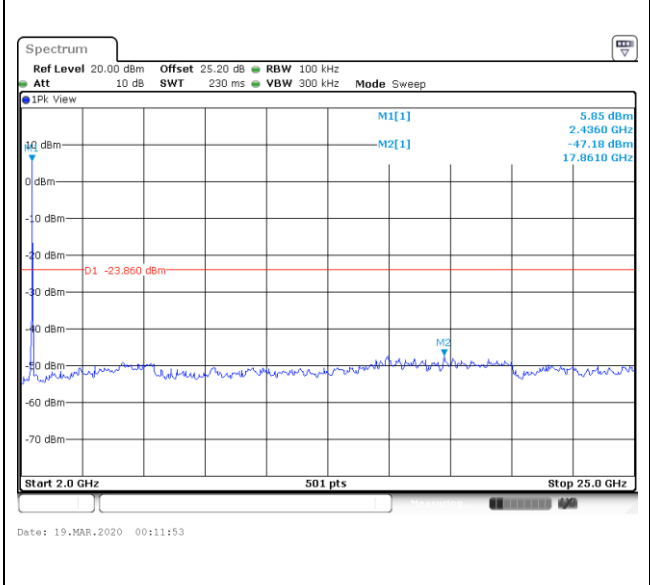
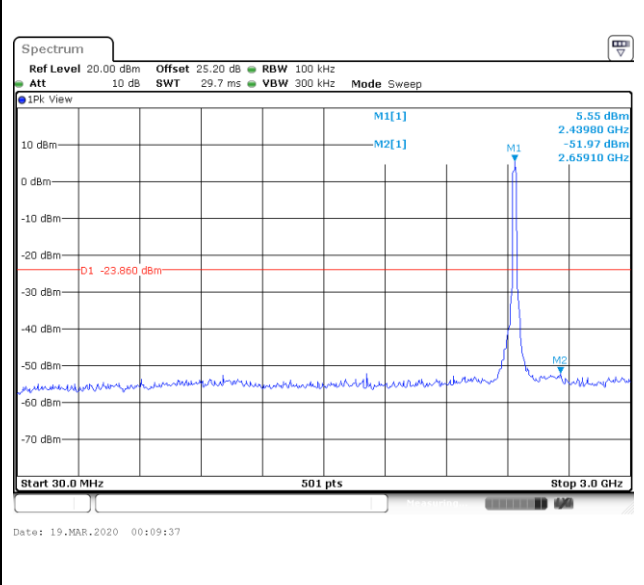



Test Mode :	802.11g	Test Channel :	11
-------------	---------	----------------	----

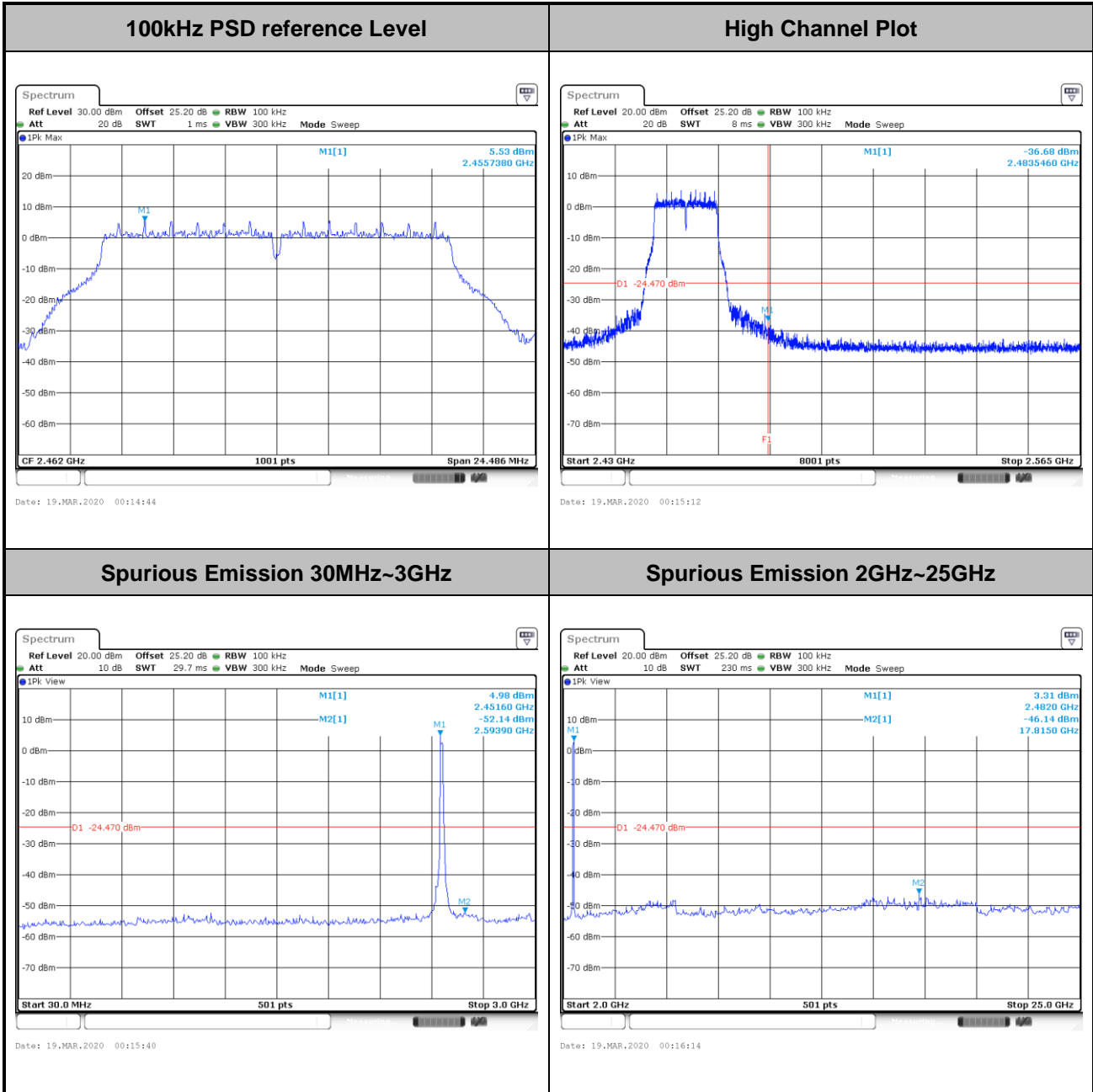



Test Mode :	802.11n HT20	Test Channel :	01
-------------	--------------	----------------	----

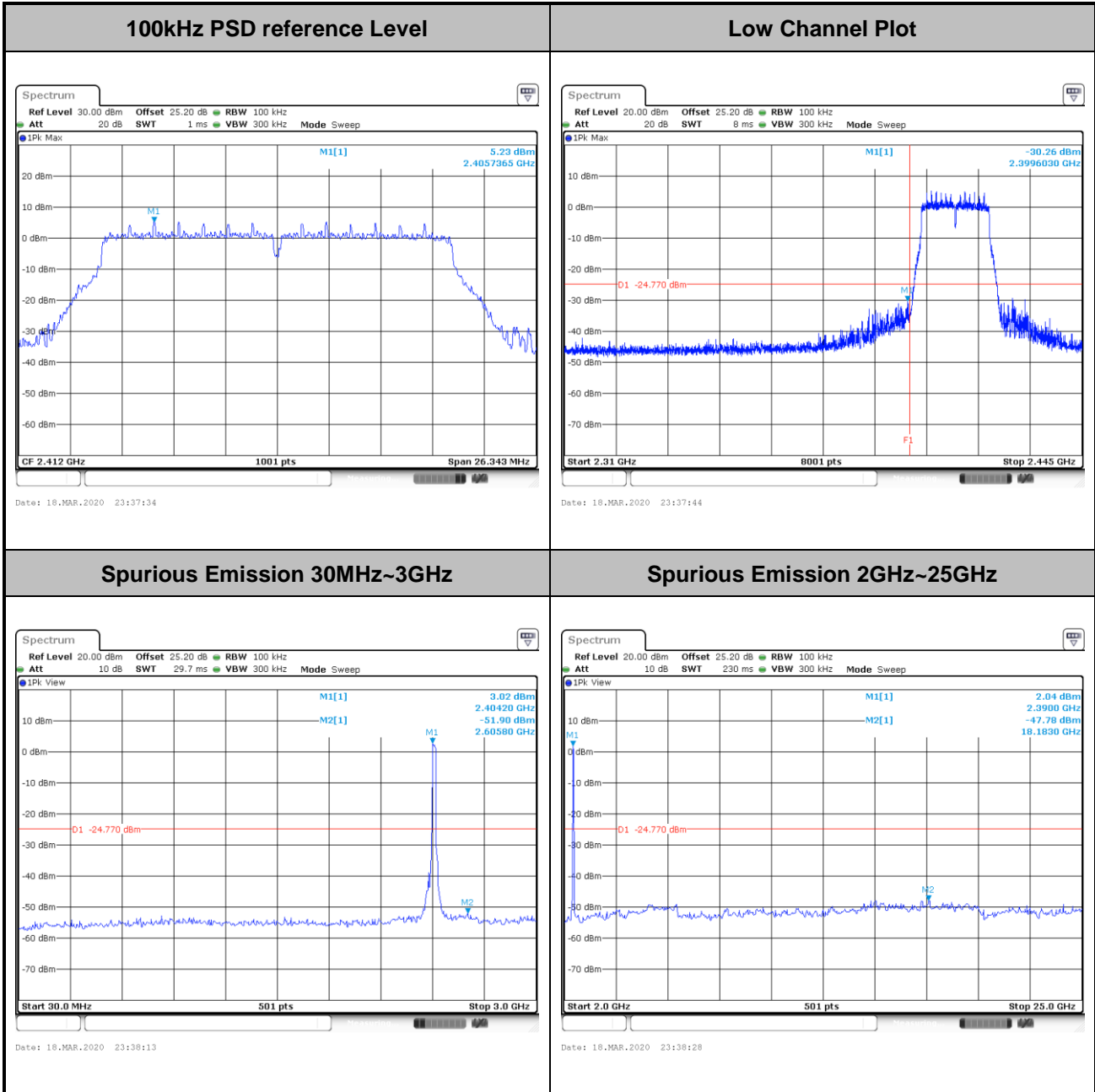



Test Mode :	802.11n HT20	Test Channel :	06
-------------	--------------	----------------	----

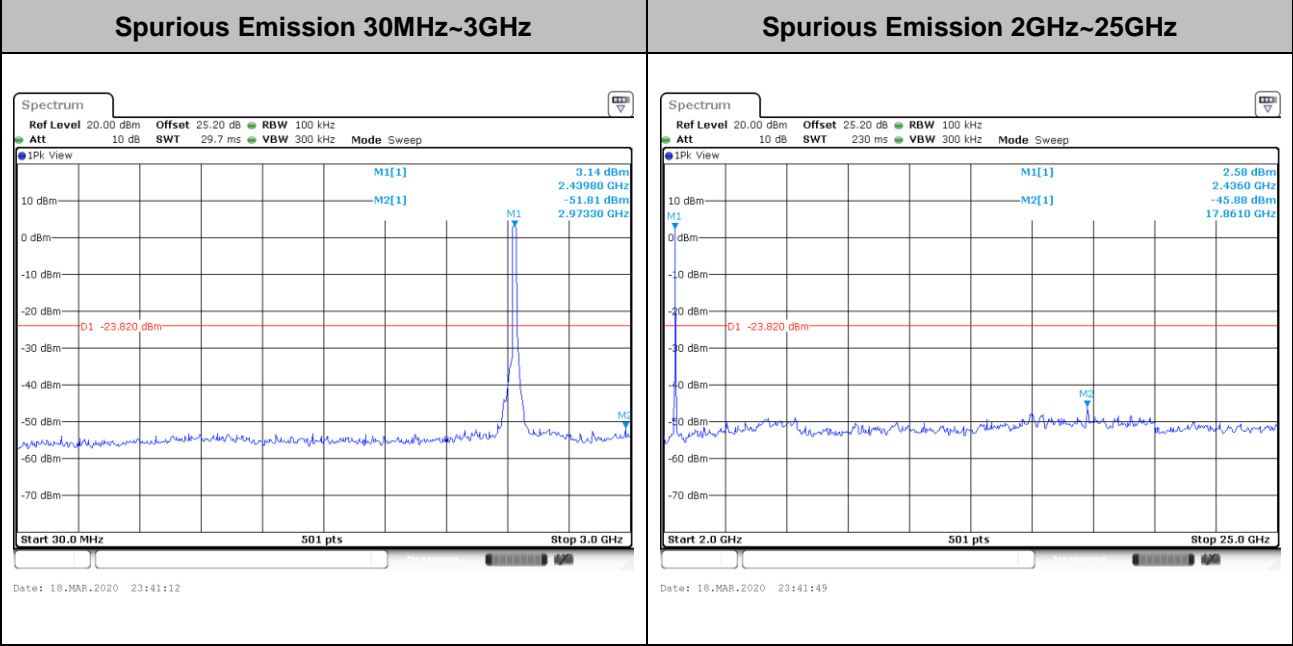
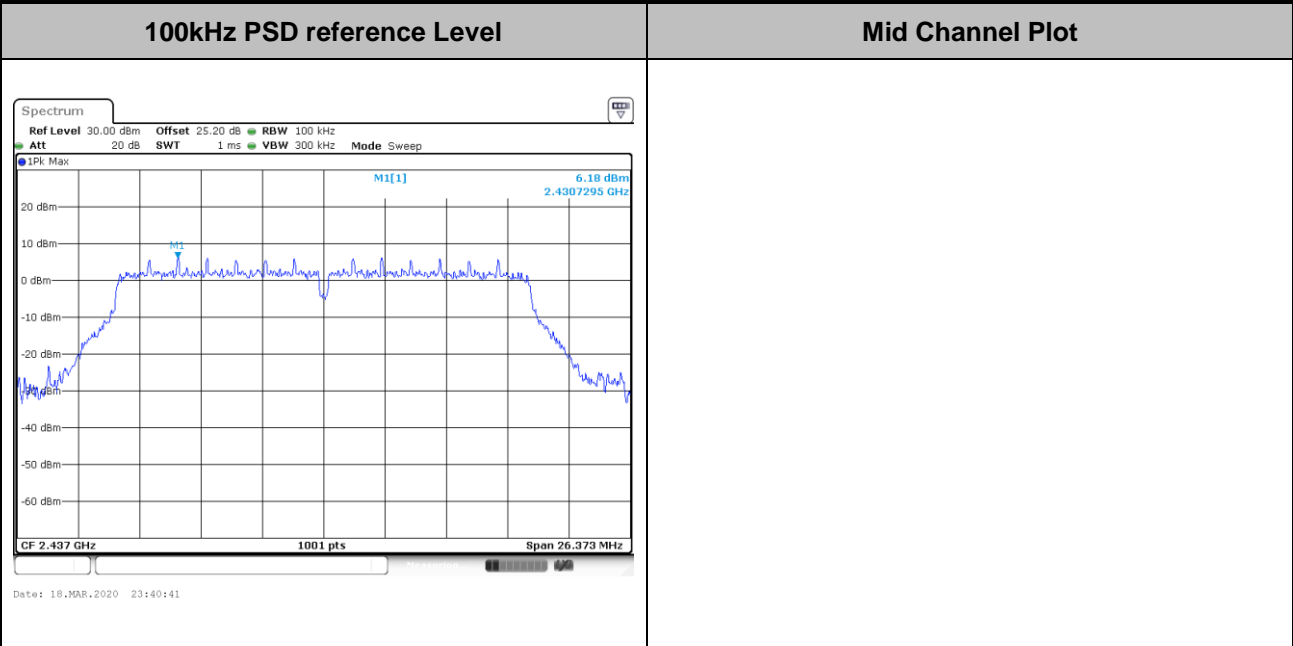



Test Mode :	802.11n HT20	Test Channel :	10
-------------	--------------	----------------	----

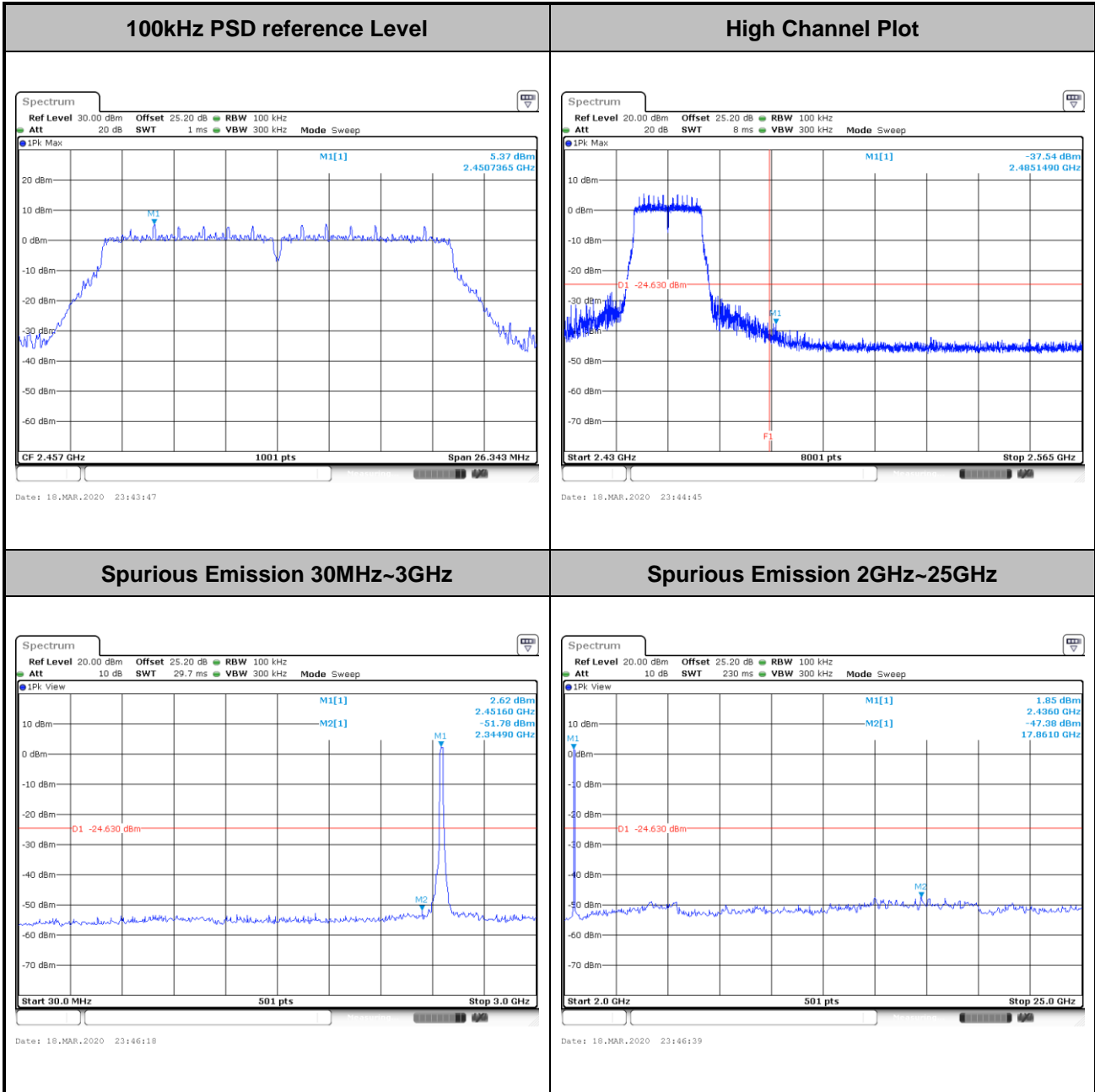



Test Mode :	802.11n HT20	Test Channel :	11
-------------	--------------	----------------	----

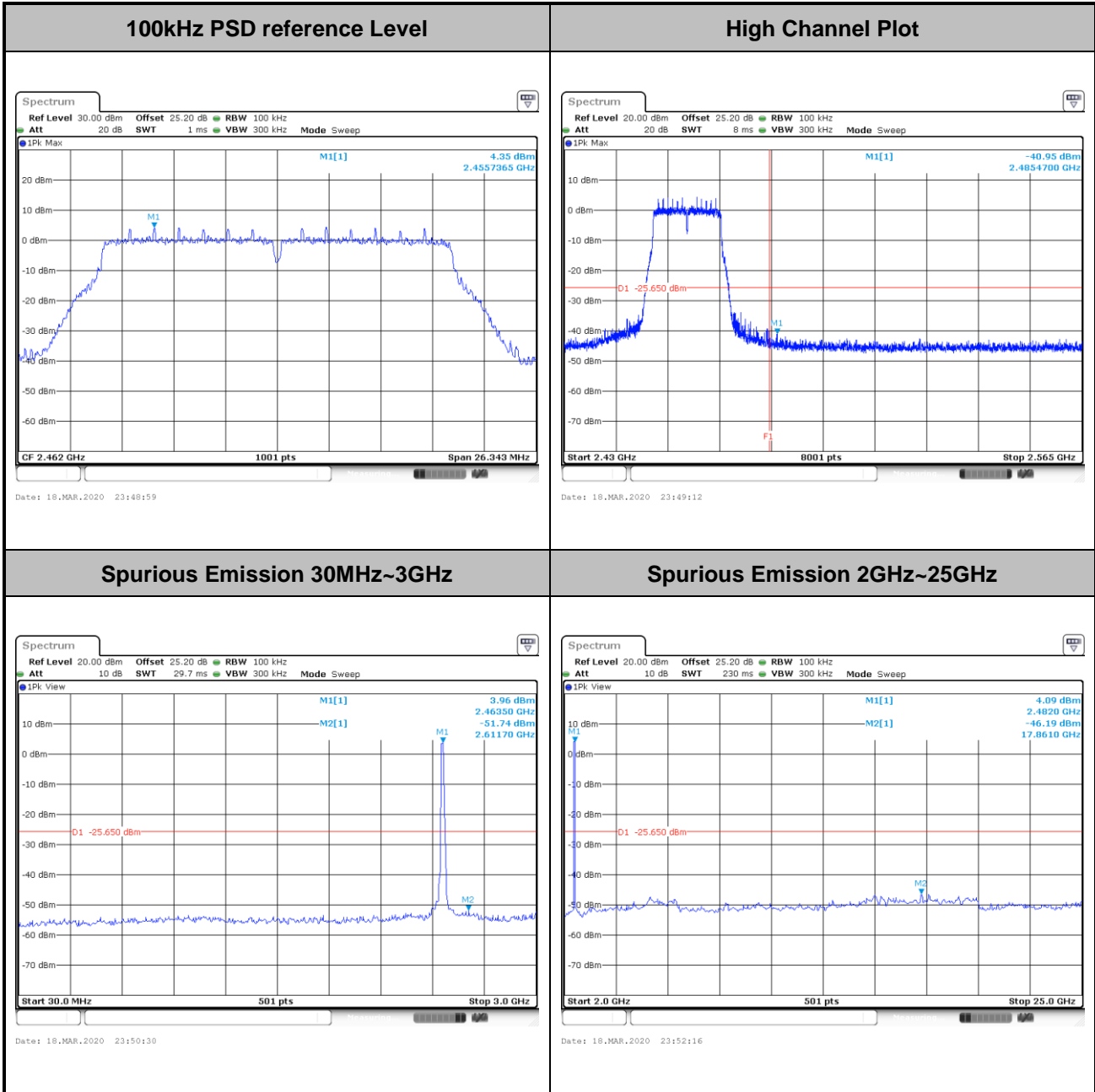



3.5 Radiated Band Edges and Spurious Emission Measurement

3.5.1 Limit of Radiated band edge and Spurious Emission Measurement

In any 100 kHz bandwidth outside the intentional radiator frequency band, all harmonics/spurious must be at least 20 dB below the highest emission level within the authorized band. If the output power of this device was measured by spectrum analyzer, the attenuation under this paragraph shall be 30 dB instead of 20 dB. In addition, radiated emissions which fall in the restricted bands must also comply with the limits as below.

Frequency (MHz)	Field Strength (microvolts/meter)	Measurement Distance (meters)
0.009 – 0.490	2400/F(kHz)	300
0.490 – 1.705	24000/F(kHz)	30
1.705 – 30.0	30	30
30 – 88	100	3
88 – 216	150	3
216 - 960	200	3
Above 960	500	3

3.5.2 Measuring Instruments

See list of measuring equipment of this test report.



3.5.3 Test Procedures

1. The testing follows the ANSI C63.10 Section 11.12.1 Radiated emission measurements.
2. The EUT was arranged to its worst case and then tune the antenna tower (from 1 m to 4 m) and turntable (from 0 degree to 360 degrees) to find the maximum reading. A pre-amp and a high pass filter are used for the test in order to get better signal level.
3. The EUT was placed on a turntable with 0.8 meter for frequency below 1GHz and 1.5 meter for frequency above 1GHz respectively above ground.
4. The EUT was set 3 meters from the interference receiving antenna, which was mounted on the top of a variable height antenna tower.
5. Corrected Reading: Antenna Factor + Cable Loss + Read Level - Preamp Factor = Level
6. For testing below 1GHz, if the emission level of the EUT in peak mode was 3 dB lower than the limit specified, then peak values of EUT will be reported, otherwise, the emissions will be repeated one by one using the CISPR quasi-peak method and reported.
7. For testing above 1GHz, the emission level of the EUT in peak mode was 20dB lower than average limit (that means the emission level in average mode also complies with the limit in average mode), then peak values of EUT will be reported, otherwise, the emissions will be measured in average mode again and reported.
8. Use the following spectrum analyzer settings:
 - (1) Span shall wide enough to fully capture the emission being measured;
 - (2) Set RBW=100 kHz for $f < 1$ GHz; $VBW \geq RBW$; Sweep = auto; Detector function = peak; Trace = max hold;
 - (3) Set RBW = 1 MHz, VBW= 3MHz for $f \geq 1$ GHz for peak measurement.
For average measurement:
 - $VBW = 10$ Hz, when duty cycle is no less than 98 percent.
 - $VBW \geq 1/T$, when duty cycle is less than 98 percent where T is the minimum transmission duration over which the transmitter is on and is transmitting at its maximum power control level for the tested mode of operation.

3.5.4 Test Setup

For radiated emissions below 30MHz

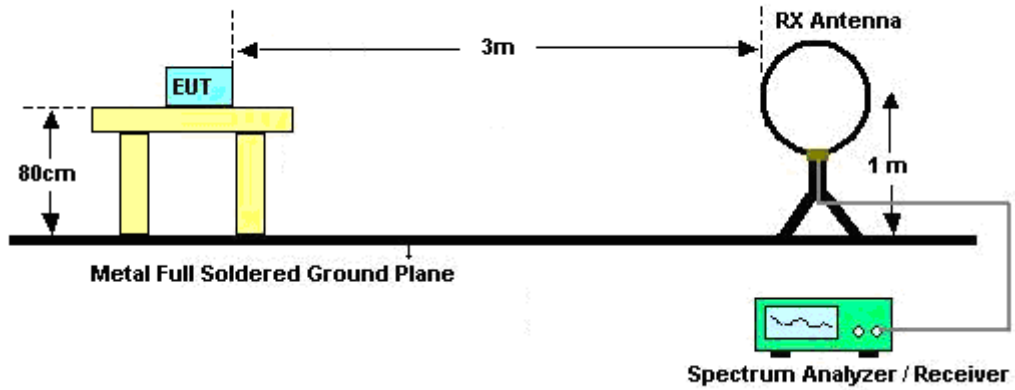

For radiated emissions from 30MHz to 1GHz

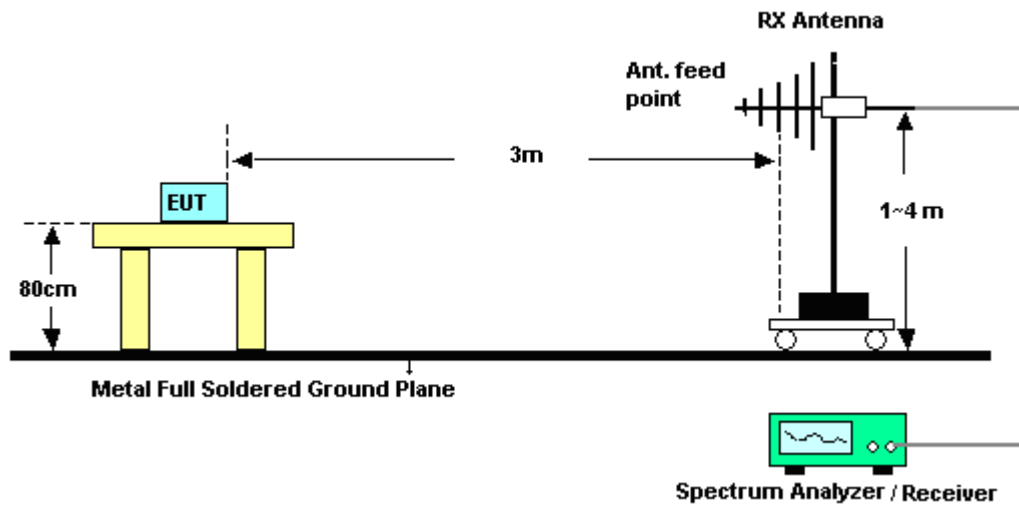

For radiated emissions above 1GHz

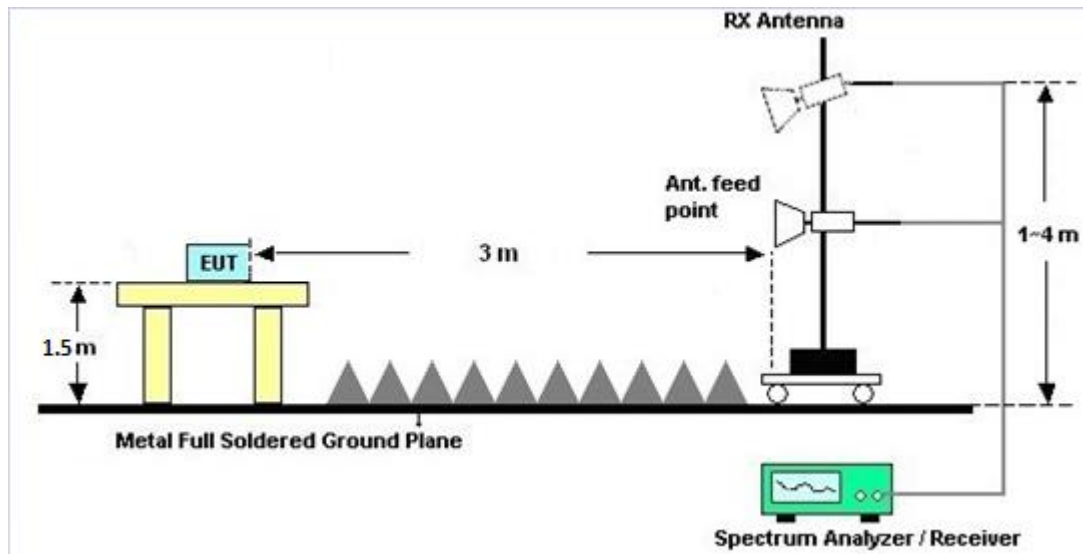

3.5.5 Test Results of Radiated Spurious Emissions (9kHz ~ 30MHz)

The low frequency, which started from 9 kHz to 30MHz, was pre-scanned and the result which was 20dB lower than the limit line was not reported.

There is a comparison data of both open-field test site and alternative test site - semi-Anechoic chamber according to 414788 D01 Radiated Test Site v01r01, and the result came out very similar.

3.5.6 Test Result of Radiated Spurious at Band Edges

Please refer to Appendix C and D.

3.5.7 Duty Cycle

Please refer to Appendix E.

3.5.8 Test Result of Radiated Spurious Emission (30MHz ~ 10th Harmonic)

Please refer to Appendix C and D.



3.6 AC Conducted Emission Measurement

3.6.1 Limit of AC Conducted Emission

For equipment that is designed to be connected to the public utility (AC) power line, the radio frequency voltage that is conducted back onto the AC power line on any frequency or frequencies within the band 150 kHz to 30 MHz shall not exceed the limits in the following table.

Frequency of Emission (MHz)	Conducted Limit (dBµV)	
	Quasi-Peak	Average
0.15-0.5	66 to 56*	56 to 46*
0.5-5	56	46
5-30	60	50

*Decreases with the logarithm of the frequency.

3.6.2 Measuring Instruments

See list of measuring equipment of this test report.

3.6.3 Test Procedures

1. The EUT was placed 0.4 meter from the conducting wall of the shielding room, and it was kept at least 80 centimeters from any other grounded conducting surface.
2. Connect EUT to the power mains through a line impedance stabilization network (LISN).
3. All the support units are connecting to the other LISN.
4. The LISN provides 50 ohm coupling impedance for the measuring instrument.
5. The FCC states that a 50 ohm, 50 microhenry LISN should be used.
6. Both sides of AC line were checked for maximum conducted interference.
7. The frequency range from 150 kHz to 30 MHz was searched.
8. Set the test-receiver system to Peak Detect Function and specified bandwidth (IF bandwidth = 9kHz) with Maximum Hold Mode.

3.6.4 Test Setup

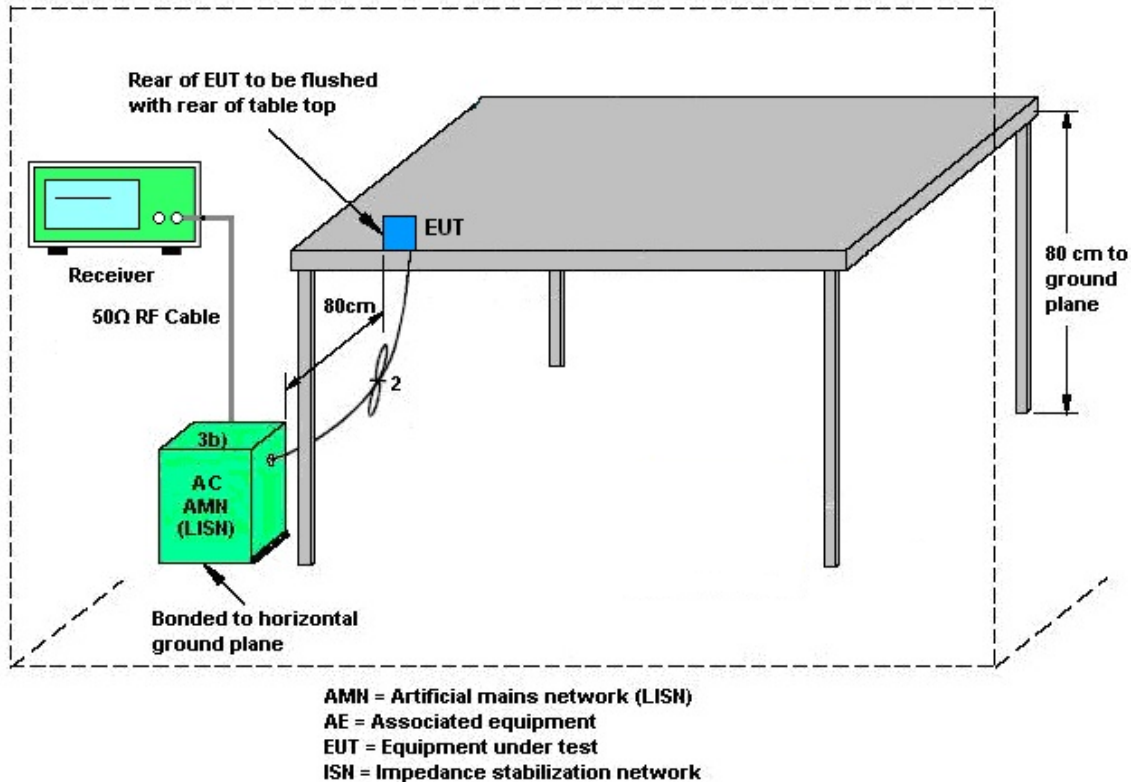

3.6.5 Test Result of AC Conducted Emission

Please refer to Appendix B.



3.7 Antenna Requirements

3.7.1 Standard Applicable

If directional gain of transmitting Antennas is greater than 6dBi, the power shall be reduced by the same level in dB comparing to gain minus 6dBi. The use of a permanently attached Antenna or of an Antenna that uses a unique coupling to the intentional radiator shall be considered sufficient to comply with the rule.

3.7.2 Antenna Anti-Replacement Construction

An embedded-in antenna design is used.

3.7.3 Antenna Gain

The antenna peak gain of EUT is less than 6 dBi. Therefore, it is not necessary to reduce maximum peak output power limit.



4 List of Measuring Equipment

Instrument	Manufacturer	Model No.	Serial No.	Characteristics	Calibration Date	Test Date	Due Date	Remark
Hygrometer	Testo	608-H2	41410069	N/A	Jun. 17, 2019	Feb. 03, 2020~ Mar. 19, 2020	Jun. 16, 2020	Conducted (TH05-HY)
Power Sensor	DARE	RPR3006W	16I00054S NO10	10MHz~6GHz	Dec. 23, 2019	Feb. 03, 2020~ Mar. 19, 2020	Dec. 22, 2020	Conducted (TH05-HY)
Signal Analyzer	Rohde & Schwarz	FSV40	101566	10Hz~40GHz	Jul. 15, 2019	Feb. 03, 2020~ Mar. 19, 2020	Jul. 14, 2020	Conducted (TH05-HY)
Spectrum Analyzer	Rohde & Schwarz	FSP40	100055	9kHz~40GHz	Aug. 14, 2019	Feb. 03, 2020~ Mar. 19, 2020	Aug. 13, 2020	Conducted (TH05-HY)
Switch Control Manframe	E-IUSTRUMENT	ETF-1405-0	EC190006 7	N/A	Aug. 15, 2019	Feb. 03, 2020~ Mar. 19, 2020	Aug. 14, 2020	Conducted (TH05-HY)
AC Power Source	ChainTek	APC-1000W	N/A	N/A	N/A	Feb. 26, 2020	N/A	Conduction (CO05-HY)
EMI Test Receiver	Rohde & Schwarz	ESR3	102388	9kHz~3.6GHz	Nov. 15, 2019	Feb. 26, 2020	Nov. 14, 2020	Conduction (CO05-HY)
Hygrometer	Testo	608-H1	34913912	N/A	Mar. 19, 2019	Feb. 26, 2020	Mar. 18, 2020	Conduction (CO05-HY)
LISN	Rohde & Schwarz	ENV216	100080	9kHz~30MHz	Nov. 20, 2019	Feb. 26, 2020	Nov. 19, 2020	Conduction (CO05-HY)
LISN	Rohde & Schwarz	ENV216	100081	9kHz~30MHz	Nov. 15, 2019	Feb. 26, 2020	Nov. 14, 2020	Conduction (CO05-HY)
Software	Rohde & Schwarz	EMC32 V10.30	N/A	N/A	N/A	Feb. 26, 2020	N/A	Conduction (CO05-HY)
LF Cable	HUBER + SUHNER	RG-214/U	LF01	N/A	Jan. 02, 2020	Feb. 26, 2020	Jan. 01, 2021	Conduction (CO05-HY)
Pulse Limiter	Rohde & Schwarz	ESH3-Z2	100851	N/A	Jan. 02, 2020	Feb. 26, 2020	Jan. 01, 2021	Conduction (CO05-HY)
Loop Antenna	Rohde & Schwarz	HFH2-Z2	100315	9 kHz~30 MHz	Dec. 26, 2019	Feb. 14, 2020~ Mar. 25, 2020	Dec. 25, 2020	Radiation (03CH12-HY)
Bilog Antenna	TESEQ	CBL 6111D & 00800N1D01 N-06	37059 & 01	30MHz~1GHz	Oct. 12, 2019	Feb. 14, 2020~ Mar. 25, 2020	Oct. 11, 2020	Radiation (03CH12-HY)
Horn Antenna	SCHWARZBE CK	BBHA 9120D	9120D-132 8	1GHz ~ 18GHz	Nov. 14, 2019	Feb. 14, 2020~ Mar. 25, 2020	Nov. 13, 2020	Radiation (03CH12-HY)
SHF-EHF Horn Antenna	SCHWARZBE CK	BBHA 9170	BBHA9170 584	18GHz ~ 40GHz	Dec. 10, 2019	Feb. 14, 2020~ Mar. 25, 2020	Dec. 09, 2020	Radiation (03CH12-HY)
Preamplifier	SONOMA	310N	187312	9kHz~1GHz	Dec. 03, 2019	Feb. 14, 2020~ Mar. 25, 2020	Dec. 02, 2020	Radiation (03CH12-HY)
Preamplifier	Jet-Power	JAP00101800 -30-10P	160118550 004	1GHz~18GHz	Sep. 27, 2019	Feb. 14, 2020~ Mar. 25, 2020	Sep. 26, 2020	Radiation (03CH12-HY)
Preamplifier	Keysight	83017A	MY532701 48	1GHz~26.5GHz	Dec. 20, 2019	Feb. 14, 2020~ Mar. 25, 2020	Dec. 19, 2020	Radiation (03CH12-HY)
Preamplifier	EMEC	EM18G40G	060715	18GHz ~ 40GHz	Dec. 13, 2019	Feb. 14, 2020~ Mar. 25, 2020	Dec. 12, 2020	Radiation (03CH12-HY)
Spectrum Analyzer	Rohde & Schwarz	FSV40	101408	10Hz~40GHz	Aug. 13, 2019	Feb. 14, 2020~ Mar. 25, 2020	Aug. 12, 2020	Radiation (03CH12-HY)
Hygrometer	TECPEL	DTM-303B	TP161243	N/A	May 11, 2019	Feb. 14, 2020~ Mar. 25, 2020	May 10, 2020	Radiation (03CH12-HY)



Instrument	Manufacturer	Model No.	Serial No.	Characteristics	Calibration Date	Test Date	Due Date	Remark
Cable	HUBER + SUHNER	SUCOFLEX 126E	0058/126E	30M-18G	Dec. 12, 2019	Feb. 14, 2020~ Mar. 25, 2020	Dec. 11, 2020	Radiation (03CH12-HY)
RF Cable	HUBER + SUHNER	SUCOFLEX 126E	0058/126E	30M-18G	Dec. 12, 2019	Feb. 14, 2020~ Mar. 25, 2020	Dec. 11, 2020	Radiation (03CH12-HY)
RF Cable	HUBER + SUHNER	SUCOFLEX 102	505134/2	30M~40GHz	Feb. 25, 2019	Feb. 14, 2020~ Feb. 19, 2020	Feb. 24, 2020	Radiation (03CH12-HY)
RF Cable	HUBER + SUHNER	SUCOFLEX 102	505134/2	30M~40GHz	Feb. 25, 2020	Feb. 25, 2020~ Mar. 25, 2020	Feb. 24, 2021	Radiation (03CH12-HY)
RF Cable	HUBER + SUHNER	SUCOFLEX 102	800740/2	30M~40GHz	Feb. 25, 2019	Feb. 14, 2020~ Feb. 19, 2020	Feb. 24, 2020	Radiation (03CH12-HY)
RF Cable	HUBER + SUHNER	SUCOFLEX 102	800740/2	30M~40GHz	Feb. 25, 2020	Feb. 25, 2020~ Mar. 25, 2020	Feb. 24, 2021	Radiation (03CH12-HY)
Controller	EMEC	EM1000	N/A	Control Turn table & Ant Mast	N/A	Feb. 14, 2020~ Mar. 25, 2020	N/A	Radiation (03CH12-HY)
Antenna Mast	EMEC	AM-BS-4500-B	N/A	1m~4m	N/A	Feb. 14, 2020~ Mar. 25, 2020	N/A	Radiation (03CH12-HY)
Turn Table	EMEC	TT2000	N/A	0~360 Degree	N/A	Feb. 14, 2020~ Mar. 25, 2020	N/A	Radiation (03CH12-HY)
Software	Audix	E3 6.2009-8-24	RK-00098 9	N/A	N/A	Feb. 14, 2020~ Mar. 25, 2020	N/A	Radiation (03CH12-HY)
Filter	Wainwright	WLK4-1000-1 530-8000-40S S	SN11	1.53GHz Low Pass Filter	Sep. 15, 2019	Feb. 14, 2020~ Mar. 25, 2020	Sep. 14, 2020	Radiation (03CH12-HY)
Filter	Wainwright	WHKX12-270 0-3000-18000 -60SS	SN3	3GHz High Pass Filter	Sep. 15, 2019	Feb. 14, 2020~ Mar. 25, 2020	Sep. 14, 2020	Radiation (03CH12-HY)



5 Uncertainty of Evaluation

Uncertainty of Conducted Emission Measurement (150kHz ~ 30MHz)

Measuring Uncertainty for a Level of Confidence of 95% ($U = 2Uc(y)$)	2.3
---	-----

Uncertainty of Radiated Emission Measurement (30 MHz ~ 1000 MHz)

Measuring Uncertainty for a Level of Confidence of 95% ($U = 2Uc(y)$)	5.1
---	-----

Uncertainty of Radiated Emission Measurement (1000 MHz ~ 18000 MHz)

Measuring Uncertainty for a Level of Confidence of 95% ($U = 2Uc(y)$)	5.6
---	-----

Uncertainty of Radiated Emission Measurement (18000 MHz ~ 40000 MHz)

Measuring Uncertainty for a Level of Confidence of 95% ($U = 2Uc(y)$)	5.0
---	-----

Appendix A. Test Result of Conducted Test Items

Test Engineer:	Kathy Chen/Derek Hsu	Temperature:	21~25	°C
Test Date:	2020/02/03~2020/03/19	Relative Humidity:	51~54	%

TEST RESULTS DATA
6dB and 99% Occupied Bandwidth

2.4GHz Band Single Antenna										
Mod.	Data Rate	NTX	CH.	Freq. (MHz)	99% Occupied BW (MHz)		6dB BW (MHz)		6dB BW Limit (MHz)	Pass/Fail
					Ant1	Ant2	Ant1	Ant2		
11b	1Mbps	1	1	2412	10.29	-	7.07	-	0.50	Pass
11b	1Mbps	1	6	2437	10.29	-	7.07	-	0.50	Pass
11b	1Mbps	1	11	2462	10.29	-	7.07	-	0.50	Pass
11g	6Mbps	1	1	2412	17.18	-	16.32	-	0.50	Pass
11g	6Mbps	1	6	2437	17.28	-	16.32	-	0.50	Pass
11g	6Mbps	1	11	2462	17.13	-	16.32	-	0.50	Pass
HT20	MCS0	1	1	2412	18.18	-	17.56	-	0.50	Pass
HT20	MCS0	1	6	2437	18.38	-	17.58	-	0.50	Pass
HT20	MCS0	1	10	2457	18.23	-	17.56	-	0.50	Pass
HT20	MCS0	1	11	2462	18.28	-	17.56	-	0.50	Pass

TEST RESULTS DATA
Average Output Power

2.4GHz Band Single Antenna																
Mod.	Data Rate	N _{Tx}	CH.	Freq. (MHz)	Average Conducted Power (dBm)			Conducted Power Limit (dBm)		DG (dBi)		EIRP Power (dBm)		EIRP Power Limit (dBm)		Pass /Fail
					Ant1	Ant2	SUM	Ant1	Ant2	Ant1	Ant2	Ant1	Ant2	Ant1	Ant2	
11b	1Mbps	1	1	2412	17.60	-		30.00	-	3.02	-	20.62	-	36.00	-	Pass
11b	1Mbps	1	6	2437	17.70	-		30.00	-	3.02	-	20.72	-	36.00	-	Pass
11b	1Mbps	1	11	2462	16.50	-		30.00	-	3.02	-	19.52	-	36.00	-	Pass
11g	6Mbps	1	1	2412	16.60	-		30.00	-	3.02	-	19.62	-	36.00	-	Pass
11g	6Mbps	1	6	2437	17.70	-		30.00	-	3.02	-	20.72	-	36.00	-	Pass
11g	6Mbps	1	11	2462	16.50	-		30.00	-	3.02	-	19.52	-	36.00	-	Pass
HT20	MCS0	1	1	2412	16.40	-		30.00	-	3.02	-	19.42	-	36.00	-	Pass
HT20	MCS0	1	6	2437	17.70	-		30.00	-	3.02	-	20.72	-	36.00	-	Pass
HT20	MCS0	1	10	2457	16.70	-		30.00	-	3.02	-	19.72	-	36.00	-	Pass
HT20	MCS0	1	11	2462	15.50	-		30.00	-	3.02	-	18.52	-	36.00	-	Pass

Note: Measured power (dBm) has offset with cable loss.

TEST RESULTS DATA
Peak Power Spectral Density

2.4GHz Band Single Antenna												
Mod.	Data Rate	N _{TX}	CH.	Freq. (MHz)	Peak PSD (dBm/3kHz)			DG (dBi)		Peak PSD Limit (dBm/3kHz)		Pass/Fail
					Ant1	Ant2	Worse + 3.01	Ant1	Ant2	Ant1	Ant2	
11b	1Mbps	1	1	2412	-2.96	-		3.02	-	8.00	-	Pass
11b	1Mbps	1	6	2437	-3.26	-		3.02	-	8.00	-	Pass
11b	1Mbps	1	11	2462	-4.31	-		3.02	-	8.00	-	Pass
11g	6Mbps	1	1	2412	-7.92	-		3.02	-	8.00	-	Pass
11g	6Mbps	1	6	2437	-7.50	-		3.02	-	8.00	-	Pass
11g	6Mbps	1	11	2462	-8.40	-		3.02	-	8.00	-	Pass
HT20	MCS0	1	1	2412	-9.06	-		3.02	-	8.00	-	Pass
HT20	MCS0	1	6	2437	-7.13	-		3.02	-	8.00	-	Pass
HT20	MCS0	1	10	2457	-8.59	-		3.02	-	8.00	-	Pass
HT20	MCS0	1	11	2462	-9.98	-		3.02	-	8.00	-	Pass

Measured power density (dBm) has offset with cable loss.



Appendix B. AC Conducted Emission Test Results

Test Engineer :	Howard Huang	Temperature :	24~25°C
		Relative Humidity :	40~45%

EUT Information

Report NO : 971035-01
 Test Mode : Mode 1
 Test Voltage : 120Vac/60Hz
 Phase : Line

Full Spectrum

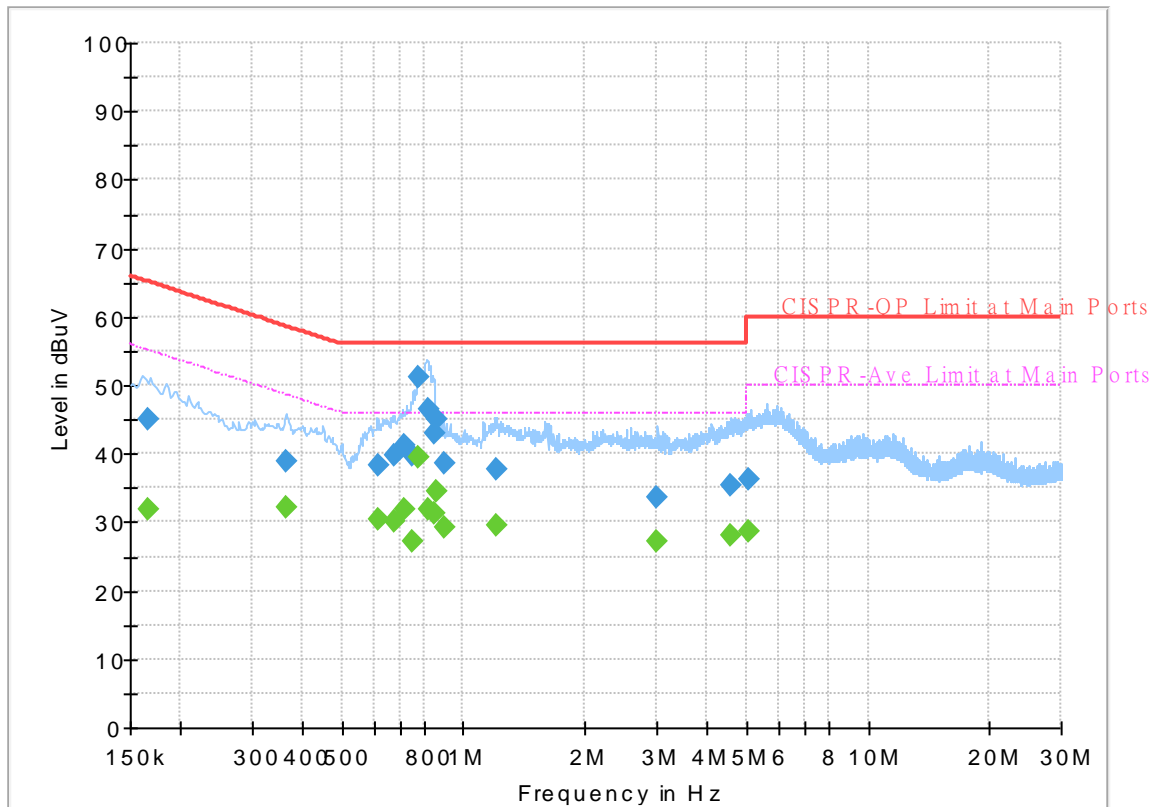

Final_Result

Frequency (MHz)	QuasiPeak (dBuV)	CAverage (dBuV)	Limit (dBuV)	Margin (dB)	Line	Filter	Corr. (dB)
0.165750	---	31.90	55.17	23.27	L1	OFF	19.5
0.165750	45.06	---	65.17	20.11	L1	OFF	19.5
0.365280	---	32.13	48.61	16.48	L1	OFF	19.5
0.365280	38.85	---	58.61	19.76	L1	OFF	19.5
0.613590	---	30.40	46.00	15.60	L1	OFF	19.5
0.613590	38.36	---	56.00	17.64	L1	OFF	19.5
0.674250	---	30.03	46.00	15.97	L1	OFF	19.5
0.674250	39.79	---	56.00	16.21	L1	OFF	19.5
0.714750	---	31.91	46.00	14.09	L1	OFF	19.5
0.714750	41.33	---	56.00	14.67	L1	OFF	19.5
0.744000	---	27.10	46.00	18.90	L1	OFF	19.5
0.744000	39.69	---	56.00	16.31	L1	OFF	19.5
0.773250	---	39.51	46.00	6.49	L1	OFF	19.6
0.773250	51.12	---	56.00	4.88	L1	OFF	19.6
0.814830	---	31.96	46.00	14.04	L1	OFF	19.6
0.814830	46.44	---	56.00	9.56	L1	OFF	19.6
0.843990	---	31.34	46.00	14.66	L1	OFF	19.6
0.843990	43.05	---	56.00	12.95	L1	OFF	19.6
0.861720	---	34.44	46.00	11.56	L1	OFF	19.6
0.861720	45.17	---	56.00	10.83	L1	OFF	19.6
0.894750	---	29.20	46.00	16.80	L1	OFF	19.6

0.894750	38.67	---	56.00	17.33	L1	OFF	19.6
1.204620	---	29.51	46.00	16.49	L1	OFF	19.6
1.204620	37.58	---	56.00	18.42	L1	OFF	19.6
3.014610	---	27.33	46.00	18.67	L1	OFF	19.7
3.014610	33.65	---	56.00	22.35	L1	OFF	19.7
4.598250	---	28.09	46.00	17.91	L1	OFF	19.7
4.598250	35.34	---	56.00	20.66	L1	OFF	19.7
5.100000	---	28.53	50.00	21.47	L1	OFF	19.7
5.100000	36.18	---	60.00	23.82	L1	OFF	19.7

EUT Information

Report NO : 971035-01
 Test Mode : Mode 1
 Test Voltage : 120Vac/60Hz
 Phase : Neutral

Full Spectrum

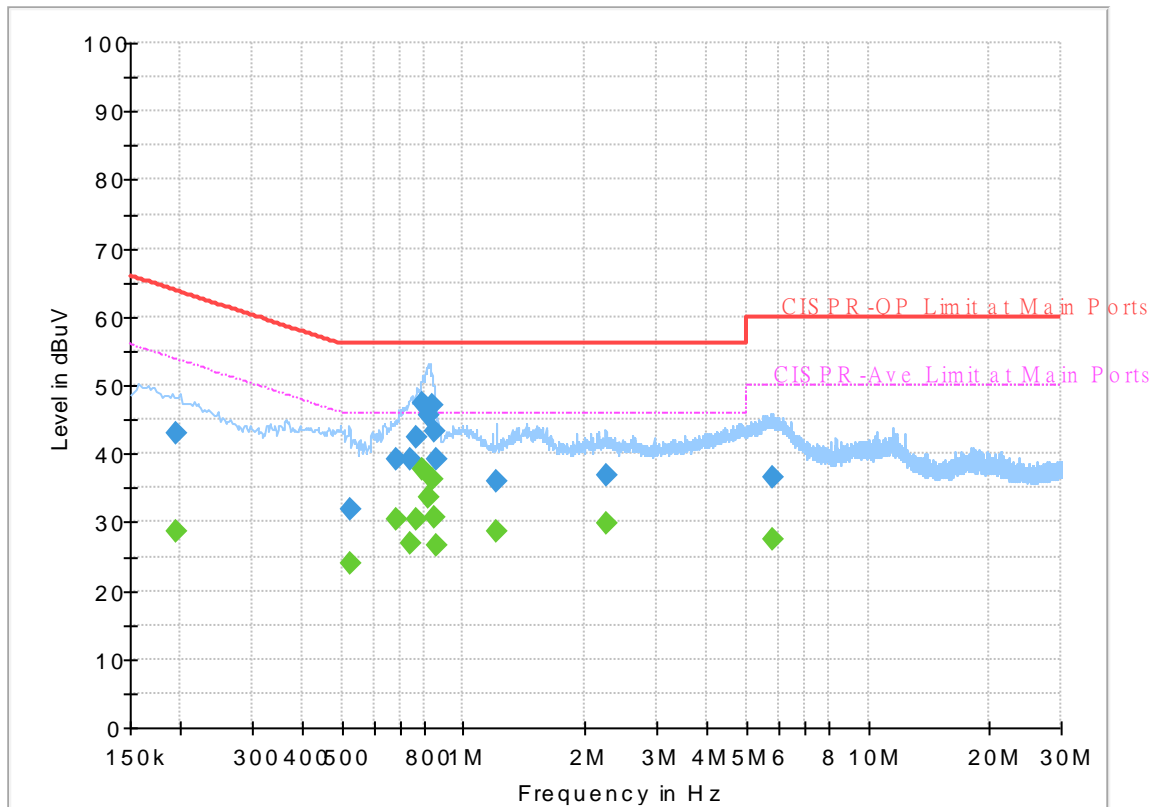

Final_Result

Frequency (MHz)	QuasiPeak (dBuV)	CAverage (dBuV)	Limit (dBuV)	Margin (dB)	Line	Filter	Corr. (dB)
0.195630	---	28.78	53.79	25.01	N	OFF	19.6
0.195630	43.01	---	63.79	20.78	N	OFF	19.6
0.525750	---	23.95	46.00	22.05	N	OFF	19.6
0.525750	31.75	---	56.00	24.25	N	OFF	19.6
0.682800	---	30.47	46.00	15.53	N	OFF	19.6
0.682800	39.33	---	56.00	16.67	N	OFF	19.6
0.736980	---	26.91	46.00	19.09	N	OFF	19.6
0.736980	39.19	---	56.00	16.81	N	OFF	19.6
0.766950	---	30.27	46.00	15.73	N	OFF	19.6
0.766950	42.45	---	56.00	13.55	N	OFF	19.6
0.791250	---	37.70	46.00	8.30	N	OFF	19.6
0.791250	47.37	---	56.00	8.63	N	OFF	19.6
0.818610	---	33.59	46.00	12.41	N	OFF	19.6
0.818610	45.64	---	56.00	10.36	N	OFF	19.6
0.836250	---	36.31	46.00	9.69	N	OFF	19.6
0.836250	47.04	---	56.00	8.96	N	OFF	19.6
0.843000	---	30.62	46.00	15.38	N	OFF	19.6
0.843000	43.14	---	56.00	12.86	N	OFF	19.6
0.858210	---	26.73	46.00	19.27	N	OFF	19.6
0.858210	39.10	---	56.00	16.90	N	OFF	19.6
1.209750	---	28.54	46.00	17.46	N	OFF	19.6

1.209750	35.91	---	56.00	20.09	N	OFF	19.6
2.251500	---	29.82	46.00	16.18	N	OFF	19.6
2.251500	36.86	---	56.00	19.14	N	OFF	19.6
5.789760	---	27.60	50.00	22.40	N	OFF	19.8
5.789760	36.45	---	60.00	23.55	N	OFF	19.8



Appendix C. Radiated Spurious Emission

Test Engineer :	Jack Cheng, Lance Chiang and Chuan Chu	Temperature :	20~24°C
		Relative Humidity :	50~56%

2.4GHz 2400~2483.5MHz

WIFI 802.11b (Band Edge @ 3m)

WIFI Ant.	Note	Frequency (MHz)	Level (dBμV/m)	Over Limit (dB)	Limit Line (dBμV/m)	Read Level (dBμV)	Antenna Factor (dB/m)	Path Loss (dB)	Preamp Factor (dB)	Ant Pos (cm)	Table Pos (deg)	Peak Avg. (P/A)	Pol. (H/V)
802.11b CH 01 2412MHz		2343.39	58.58	-15.42	74	43.67	27.63	16.57	29.29	321	37	P	H
		2387.28	46.8	-7.2	54	31.93	27.53	16.62	29.28	321	37	A	H
	*	2412	108.37	-	-	93.51	27.48	16.65	29.27	321	37	P	H
	*	2412	104.94	-	-	90.08	27.48	16.65	29.27	321	37	A	H
		2386.965	61.56	-12.44	74	46.69	27.53	16.62	29.28	171	114	P	V
		2387.28	50.09	-3.91	54	35.22	27.53	16.62	29.28	171	114	A	V
	*	2412	112.68	-	-	97.82	27.48	16.65	29.27	171	114	P	V
	*	2412	109.24	-	-	94.38	27.48	16.65	29.27	171	114	A	V
802.11b CH 06 2437MHz		2352.28	56.91	-17.09	74	42.02	27.6	16.58	29.29	333	1	P	H
		2389.94	43.43	-10.57	54	28.56	27.52	16.63	29.28	333	1	A	H
	*	2437	109.08	-	-	94.25	27.43	16.67	29.27	333	1	P	H
	*	2437	105.53	-	-	90.7	27.43	16.67	29.27	333	1	A	H
		2493.35	57.69	-16.31	74	42.91	27.31	16.72	29.25	333	1	P	H
		2483.9	43.38	-10.62	54	28.59	27.33	16.71	29.25	333	1	A	H
		2386.16	58.05	-15.95	74	43.18	27.53	16.62	29.28	231	112	P	V
		2389.8	44.81	-9.19	54	29.94	27.52	16.63	29.28	231	112	A	V
	*	2437	112.79	-	-	97.96	27.43	16.67	29.27	231	112	P	V
	*	2437	109.42	-	-	94.59	27.43	16.67	29.27	231	112	A	V
		2487.89	58.17	-15.83	74	43.39	27.32	16.71	29.25	231	112	P	V
		2483.9	43.88	-10.12	54	29.09	27.33	16.71	29.25	231	112	A	V



802.11b CH 11 2462MHz	*	2462	109.32	-	-	94.51	27.38	16.69	29.26			P	H
	*	2462	105.84	-	-	91.03	27.38	16.69	29.26	114	179	A	H
		2486.8	58.35	-15.65	74	43.56	27.33	16.71	29.25	114	179	P	H
		2486.72	45.76	-8.24	54	30.97	27.33	16.71	29.25	114	179	A	H
	*	2462	110.76	-	-	95.95	27.38	16.69	29.26	157	136	P	V
	*	2462	107.22	-	-	92.41	27.38	16.69	29.26	157	136	A	V
		2486.04	59.08	-14.92	74	44.29	27.33	16.71	29.25	157	136	P	V
		2486.68	46.96	-7.04	54	32.17	27.33	16.71	29.25	157	136	A	V
Remark	1. No other spurious found. 2. All results are PASS against Peak and Average limit line.												



2.4GHz 2400~2483.5MHz
WIFI 802.11b (Harmonic @ 3m)

Table with 14 columns: WIFI Ant. 1, Note, Frequency (MHz), Level (dBµV/m), Over Limit (dB), Limit Line (dBµV/m), Read Level (dBµV), Antenna Factor (dB/m), Path Loss (dB), Preamp Factor (dB), Ant Pos (cm), Table Pos (deg), Peak Avg. (P/A), Pol. (H/V). Rows include data for 802.11b CH 01 (2412MHz), CH 06 (2437MHz), and CH 11 (2462MHz).



2.4GHz 2400~2483.5MHz
WIFI 802.11g (Band Edge @ 3m)

WIFI Ant. 1	Note	Frequency (MHz)	Level (dBμV/m)	Over Limit (dB)	Limit Line (dBμV/m)	Read Level (dBμV)	Antenna Factor (dB/m)	Path Loss (dB)	Preamp Factor (dB)	Ant Pos (cm)	Table Pos (deg)	Peak Avg. (P/A)	Pol. (H/V)
802.11g CH 01 2412MHz		2389.065	63.1	-10.9	74	48.23	27.52	16.63	29.28	100	178	P	H
		2389.905	46.94	-7.06	54	32.07	27.52	16.63	29.28	100	178	A	H
	*	2412	107.8	-	-	92.94	27.48	16.65	29.27	100	178	P	H
	*	2412	98.2	-	-	83.34	27.48	16.65	29.27	100	178	A	H
		2389.905	69.93	-4.07	74	55.06	27.52	16.63	29.28	151	113	P	V
		2390	49.98	-4.02	54	35.11	27.52	16.63	29.28	151	113	A	V
	*	2412	111.62	-	-	96.76	27.48	16.65	29.27	151	113	P	V
	*	2412	102.43	-	-	87.57	27.48	16.65	29.27	151	113	A	V
802.11g CH 06 2437MHz		2385.74	58.79	-15.21	74	43.92	27.53	16.62	29.28	331	1	P	H
		2389.52	44.92	-9.08	54	30.05	27.52	16.63	29.28	331	1	A	H
	*	2437	110.1	-	-	95.27	27.43	16.67	29.27	331	1	P	H
	*	2437	100.39	-	-	85.56	27.43	16.67	29.27	331	1	A	H
		2490.97	57.82	-16.18	74	43.03	27.32	16.72	29.25	331	1	P	H
		2483.97	44.86	-9.14	54	30.07	27.33	16.71	29.25	331	1	A	H
		2388.96	62.94	-11.06	74	48.07	27.52	16.63	29.28	186	112	P	V
		2388.26	47.08	-6.92	54	32.21	27.52	16.63	29.28	186	112	A	V
	*	2437	113.62	-	-	98.79	27.43	16.67	29.27	186	112	P	V
	*	2437	104.1	-	-	89.27	27.43	16.67	29.27	186	112	A	V
		2486.42	59.32	-14.68	74	44.53	27.33	16.71	29.25	186	112	P	V
		2483.83	45.71	-8.29	54	30.92	27.33	16.71	29.25	186	112	A	V



802.11g CH 11 2462MHz	*	2462	108.03	-	-	93.22	27.38	16.69	29.26	101	177	P	H
	*	2462	98.87	-	-	84.06	27.38	16.69	29.26	101	177	A	H
		2483.52	65.99	-8.01	74	51.2	27.33	16.71	29.25	101	177	P	H
		2483.56	46.49	-7.51	54	31.7	27.33	16.71	29.25	101	177	A	H
	*	2462	112.58	-	-	97.77	27.38	16.69	29.26	283	110	P	V
	*	2462	103.02	-	-	88.21	27.38	16.69	29.26	283	110	A	V
		2483.6	69.37	-4.63	74	54.58	27.33	16.71	29.25	283	110	P	V
		2483.72	48.74	-5.26	54	33.95	27.33	16.71	29.25	283	110	A	V
Remark	1. No other spurious found. 2. All results are PASS against Peak and Average limit line.												



2.4GHz 2400~2483.5MHz
WIFI 802.11g (Harmonic @ 3m)

Table with 14 columns: WIFI Ant. 1, Note, Frequency (MHz), Level (dBµV/m), Over Limit (dB), Limit Line (dBµV/m), Read Level (dBµV), Antenna Factor (dB/m), Path Loss (dB), Preamp Factor (dB), Ant Pos (cm), Table Pos (deg), Peak Avg. (P/A), Pol. (H/V). Rows include data for CH 01 (2412MHz), CH 06 (2437MHz), and CH 11 (2462MHz).



2.4GHz 2400~2483.5MHz
WIFI 802.11n HT20 (Band Edge @ 3m)

Table with 14 columns: WIFI Ant. 1, Note, Frequency (MHz), Level (dBµV/m), Over Limit (dB), Limit Line (dBµV/m), Read Level (dBµV), Antenna Factor (dB/m), Path Loss (dB), Preamp Factor (dB), Ant Pos (cm), Table Pos (deg), Peak Avg. (P/A), Pol. (H/V). Rows include data for 802.11n HT20 CH 01 (2412MHz) and 802.11n HT20 CH 06 (2437MHz).



802.11n HT20 CH 10 2457MHz	*	2457	109.94	-	-	95.86	27.39	15.95	29.26	305	58	P	H
	*	2457	100.28	-	-	86.2	27.39	15.95	29.26	305	58	A	H
		2483.76	71.64	-2.36	74	57.58	27.33	15.98	29.25	305	58	P	H
		2483.52	46.2	-7.8	54	32.14	27.33	15.98	29.25	305	58	A	H
	*	2457	109.02	-	-	94.94	27.39	15.95	29.26	269	275	P	V
	*	2457	98.54	-	-	84.46	27.39	15.95	29.26	269	275	A	V
		2488.04	64.68	-9.32	74	50.62	27.32	15.99	29.25	269	275	P	V
		2484.12	44.7	-9.3	54	30.64	27.33	15.98	29.25	269	275	A	V
802.11n HT20 CH 11 2462MHz	*	2462	106.8	-	-	91.99	27.38	16.69	29.26	100	177	P	H
	*	2462	97.59	-	-	82.78	27.38	16.69	29.26	100	177	A	H
		2484.16	67.59	-6.41	74	52.8	27.33	16.71	29.25	100	177	P	H
		2483.56	46.09	-7.91	54	31.3	27.33	16.71	29.25	100	177	A	H
	*	2462	110.98	-	-	96.17	27.38	16.69	29.26	281	111	P	V
	*	2462	101.89	-	-	87.08	27.38	16.69	29.26	281	111	A	V
		2484.84	70.04	-3.96	74	55.25	27.33	16.71	29.25	281	111	P	V
	2483.56	48.31	-5.69	54	33.52	27.33	16.71	29.25	281	111	A	V	
Remark	1. No other spurious found. 2. All results are PASS against Peak and Average limit line.												



**2.4GHz 2400~2483.5MHz
WIFI 802.11n HT20 (Harmonic @ 3m)**

WIFI Ant. 1	Note	Frequency (MHz)	Level (dBμV/m)	Over Limit (dB)	Limit Line (dBμV/m)	Read Level (dBμV)	Antenna Factor (dB/m)	Path Loss (dB)	Preamp Factor (dB)	Ant Pos (cm)	Table Pos (deg)	Peak Avg. (P/A)	Pol. (H/V)
802.11n HT20 CH 01 2412MHz		4824	44.7	-29.3	74	66.09	31.1	10.07	62.56	100	0	P	H
		4824	45.72	-28.28	74	67.11	31.1	10.07	62.56	100	0	P	V
802.11n HT20 CH 06 2437MHz		4874	43.94	-30.06	74	65.33	31.1	10.08	62.57	100	0	P	H
		7311	44.09	-29.91	74	58.81	36.34	12.5	63.56	100	0	P	H
		4874	48.41	-25.59	74	69.8	31.1	10.08	62.57	100	0	P	V
		7311	43.63	-30.37	74	58.35	36.34	12.5	63.56	100	0	P	V
802.11n HT20 CH 10 2457MHz		4914	49.12	-24.88	74	68.39	31.13	9.97	60.37	100	0	P	H
		7371	46.47	-27.53	74	56.39	36.46	12.7	59.08	100	0	P	H
		4914	53.75	-20.25	74	73.02	31.13	9.97	60.37	100	112	P	V
		4914	41.42	-12.58	54	60.69	31.13	9.97	60.37	100	112	A	V
		7371	46.26	-27.74	74	56.18	36.46	12.7	59.08	100	0	P	V
802.11n HT20 CH 11 2462MHz		4924	45.01	-28.99	74	66.37	31.15	10.07	62.58	100	0	P	H
		7386	43.07	-30.93	74	57.64	36.43	12.58	63.58	100	0	P	H
		4924	49.08	-24.92	74	70.44	31.15	10.07	62.58	100	0	P	V
		7386	43.93	-30.07	74	58.5	36.43	12.58	63.58	100	0	P	V
Remark	1. No other spurious found. 2. All results are PASS against Peak and Average limit line.												



2.4GHz 2400~2483.5MHz

Emission below 1GHz

2.4GHz WIFI 802.11b (LF)

WIFI Ant.	Note	Frequency	Level	Over Limit	Limit Line	Read Level	Antenna Factor	Path Loss	Preamp Factor	Ant Pos	Table Pos	Peak Avg.	Pol.
1		(MHz)	(dBμV/m)	(dB)	(dBμV/m)	(dBμV)	(dB/m)	(dB)	(dB)	(cm)	(deg)	(P/A)	(H/V)
2.4GHz 802.11b LF		62.01	28.07	-11.93	40	45.76	11.61	1.16	30.46	-	-	P	H
		214.3	31.39	-12.11	43.5	44.78	14.87	2.03	30.29	-	-	P	H
		499.48	31.72	-14.28	46	34.38	23.84	3.28	29.78	-	-	P	H
		664.38	36.16	-9.84	46	35.77	26.22	3.73	29.56	100	0	P	H
		884.57	34.05	-11.95	46	29.72	29.03	4.46	29.16	-	-	P	H
		960.23	36.01	-17.99	54	29.43	30.85	4.7	28.97	-	-	P	H
		30	32.39	-7.61	40	37.42	24.31	0.84	30.18	-	-	P	V
		96.93	25.33	-18.17	43.5	38.81	15.49	1.46	30.43	-	-	P	V
		219.15	26.01	-19.99	46	39.12	15.15	2.03	30.29	-	-	P	V
		666.32	39.23	-6.77	46	38.82	26.23	3.74	29.56	100	0	P	V
		864.2	34.81	-11.19	46	30.56	29.04	4.4	29.19	-	-	P	V
	956.35	36.85	-9.15	46	30.33	30.81	4.69	28.98	-	-	P	V	
Remark	1. No other spurious found. 2. All results are PASS against limit line.												



Note symbol

*	Fundamental Frequency which can be ignored. However, the level of any unwanted emissions shall not exceed the level of the fundamental frequency.
!	Test result is over limit line.
P/A	Peak or Average
H/V	Horizontal or Vertical



A calculation example for radiated spurious emission is shown as below:

WIFI	Note	Frequency	Level	Over	Limit	Read	Antenna	Path	Preamp	Ant	Table	Peak	Pol.
Ant.				Limit	Line	Level	Factor	Loss	Factor	Pos	Pos	Avg.	
1		(MHz)	(dBμV/m)	(dB)	(dBμV/m)	(dBμV)	(dB/m)	(dB)	(dB)	(cm)	(deg)	(P/A)	(H/V)
802.11b		2390	55.45	-18.55	74	54.51	32.22	4.58	35.86	103	308	P	H
CH 01													
2412MHz		2390	43.54	-10.46	54	42.6	32.22	4.58	35.86	103	308	A	H

1. Path Loss(dB) = Cable loss(dB) + Filter loss(dB) + Attenuator loss(dB)
2. Level(dBμV/m) =
Antenna Factor(dB/m) + Path Loss(dB) + Read Level(dBμV) - Preamp Factor(dB)
3. Over Limit(dB) = Level(dBμV/m) – Limit Line(dBμV/m)

For Peak Limit @ 2390MHz:

1. Level(dBμV/m)
= Antenna Factor(dB/m) + Path Loss(dB) + Read Level(dBμV) - Preamp Factor(dB)
= 32.22(dB/m) + 4.58(dB) + 54.51(dBμV) – 35.86 (dB)
= 55.45 (dBμV/m)
2. Over Limit(dB)
= Level(dBμV/m) – Limit Line(dBμV/m)
= 55.45(dBμV/m) – 74(dBμV/m)
= -18.55(dB)

For Average Limit @ 2390MHz:

1. Level(dBμV/m)
= Antenna Factor(dB/m) + Path Loss(dB) + Read Level(dBμV) - Preamp Factor(dB)
= 32.22(dB/m) + 4.58(dB) + 42.6(dBμV) – 35.86 (dB)
= 43.54 (dBμV/m)
2. Over Limit(dB)
= Level(dBμV/m) – Limit Line(dBμV/m)
= 43.54(dBμV/m) – 54(dBμV/m)
= -10.46(dB)

Both peak and average measured complies with the limit line, so test result is “PASS”.



Appendix D. Radiated Spurious Emission Plots

Test Engineer :	Jack Cheng, Lance Chiang and Chuan Chu	Temperature :	20~24°C
		Relative Humidity :	50~56%

Note symbol

-L	Low channel location
-R	High channel location

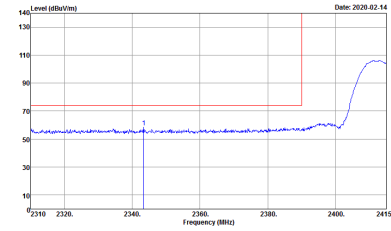
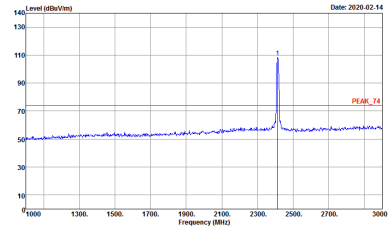
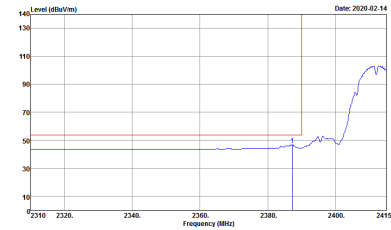
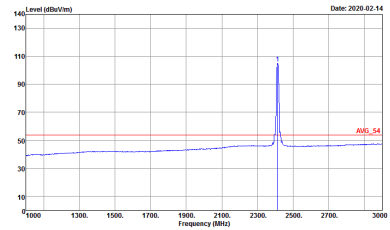

2.4GHz 2400~2483.5MHz
WIFI 802.11b (Band Edge @ 3m)

WIFI	2.4GHz 2400~2483.5MHz Band Edge @ 3m	
ANT	802.11b CH01 2412MHz	
1	Horizontal	Fundamental
Peak	 <p>Site : 03CH12-HY Condition : PEAK_BE_74 3m HORN_91200_1328 HORIZONTAL Detector : Peak Project : 971035-01 Setting : 17</p>	 <p>Site : 03CH12-HY Condition : PEAK_74 3m HORN_91200_1328 HORIZONTAL Detector : Peak Project : 971035-01 Setting : 17</p>
Avg.	 <p>Site : 03CH12-HY Condition : AVG_BE_54 3m HORN_91200_1328 HORIZONTAL Detector : Peak Project : 971035-01 Setting : 17</p>	 <p>Site : 03CH12-HY Condition : AVG_54 3m HORN_91200_1328 HORIZONTAL Detector : Peak Project : 971035-01 Setting : 17</p>

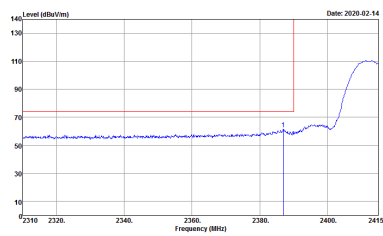
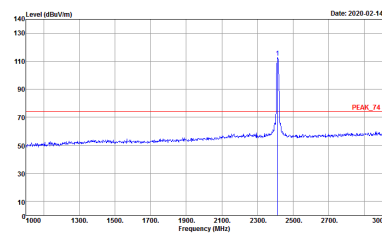
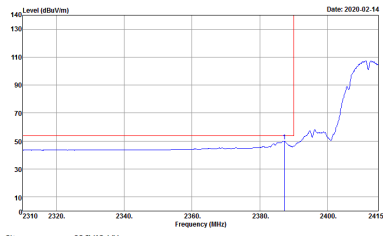
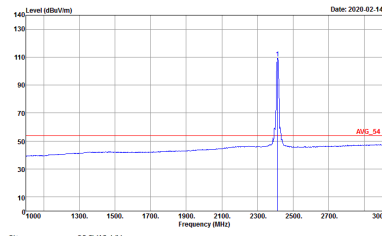

WIFI	2.4GHz 2400~2483.5MHz Band Edge @ 3m	
ANT	802.11b CH01 2412MHz	
1	Vertical	Fundamental
<p>Peak</p>	 <p>Site : 03CH12-HY Condition : PEAK_BE_74 3m HORN_9120D_1328 VERTICAL Detector : Peak Project : 971035-01 Setting : 17</p>	 <p>Site : 03CH12-HY Condition : PEAK_F4 3m HORN_9120D_1328 VERTICAL Detector : Peak Project : 971035-01 Setting : 17</p>
<p>Avg.</p>	 <p>Site : 03CH12-HY Condition : AVG_BE_54 3m HORN_9120D_1328 VERTICAL Detector : Peak Project : 971035-01 Setting : 17</p>	 <p>Site : 03CH12-HY Condition : AVG_F4 3m HORN_9120D_1328 VERTICAL Detector : Peak Project : 971035-01 Setting : 17</p>

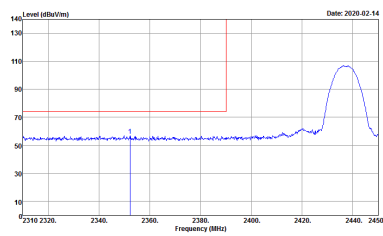
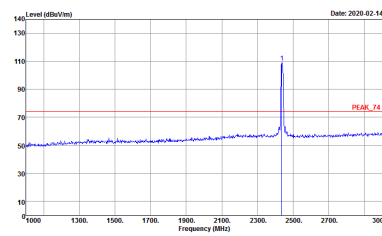
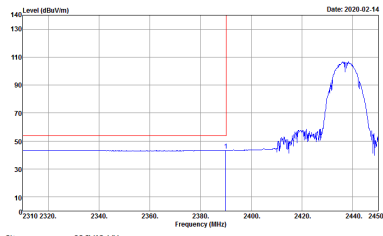
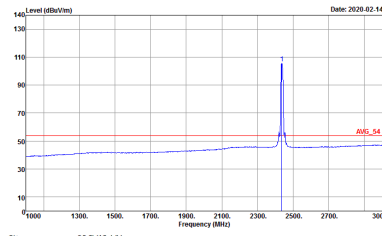

WIFI	2.4GHz 2400~2483.5MHz Band Edge @ 3m	
ANT	802.11b CH06 2437MHz - L	
1	Horizontal	Fundamental
Peak	 <p>Site : 03CH12-HY Condition : PEAK_BE_74 3m HORN_91200_1328 HORIZONTAL Detector : Peak Project : 971035-01 Setting : 17</p>	 <p>Site : 03CH12-HY Condition : PEAK_F4 3m HORN_91200_1328 HORIZONTAL Detector : Peak Project : 971035-01 Setting : 17</p>
Avg.	 <p>Site : 03CH12-HY Condition : AVG_BE_54 3m HORN_91200_1328 HORIZONTAL Detector : Peak Project : 971035-01 Setting : 17</p>	 <p>Site : 03CH12-HY Condition : AVG_F4 3m HORN_91200_1328 HORIZONTAL Detector : Peak Project : 971035-01 Setting : 17</p>



WIFI	2.4GHz 2400~2483.5MHz Band Edge @ 3m	
ANT	802.11b CH06 2437MHz - R	
1	Horizontal	Fundamental
Peak	<p>Site : 03CH2-HY Condition : PEAK_BE_74 3m HORN_9120D_1328 HORIZONTAL Detector : Peak Project : 971035-01 Setting : 17</p>	Left blank
Avg.	<p>Site : 03CH2-HY Condition : AVG_BE_54 3m HORN_9120D_1328 HORIZONTAL Detector : Peak Project : 971035-01 Setting : 17</p>	Left blank

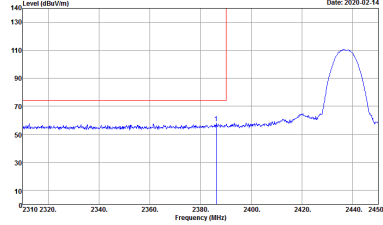
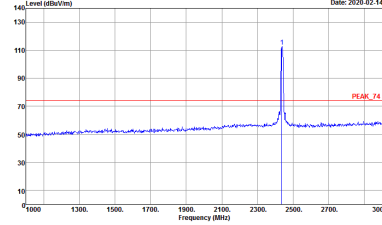
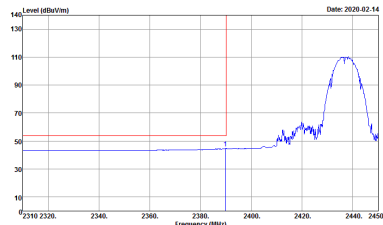
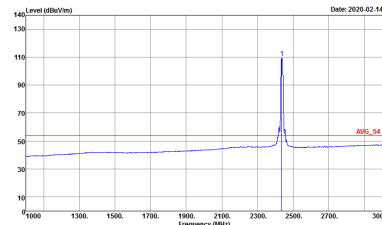

WIFI	2.4GHz 2400~2483.5MHz Band Edge @ 3m	
ANT	802.11b CH06 2437MHz - L	
1	Vertical	Fundamental
<p>Peak</p>	 <p>Site : 03CH2-HY Condition : PEAK_BE_74 3m HORN_9120D_1328 VERTICAL Detector : Peak Project : 971035-01 Setting : 17</p>	 <p>Site : 03CH2-HY Condition : PEAK_74 3m HORN_9120D_1328 VERTICAL Detector : Peak Project : 971035-01 Setting : 17</p>
<p>Avg.</p>	 <p>Site : 03CH2-HY Condition : AVG_BE_54 3m HORN_9120D_1328 VERTICAL Detector : Peak Project : 971035-01 Setting : 17</p>	 <p>Site : 03CH2-HY Condition : AVG_54 3m HORN_9120D_1328 VERTICAL Detector : Peak Project : 971035-01 Setting : 17</p>

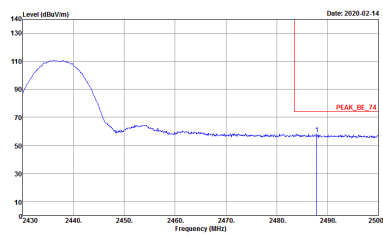
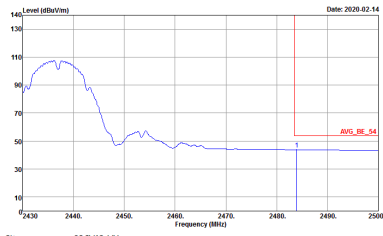

WIFI	2.4GHz 2400~2483.5MHz Band Edge @ 3m	
ANT	802.11b CH06 2437MHz - R	
1	Vertical	Fundamental
<p>Peak</p>	 <p>Site : 03CH2-HY Condition : PEAK_BE_74 3m HORN_9120D_1328 VERTICAL Detector : Peak Project : 971035-01 Setting : 17</p>	<p>Left blank</p>
<p>Avg.</p>	 <p>Site : 03CH2-HY Condition : AVG_BE_54 3m HORN_9120D_1328 VERTICAL Detector : Peak Project : 971035-01 Setting : 17</p>	<p>Left blank</p>

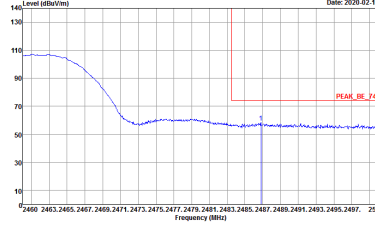
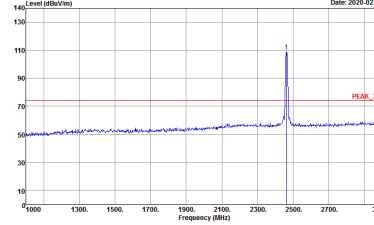
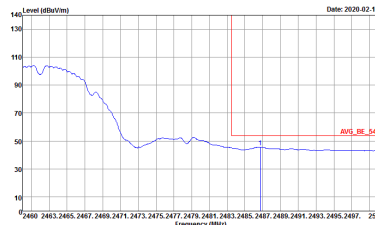
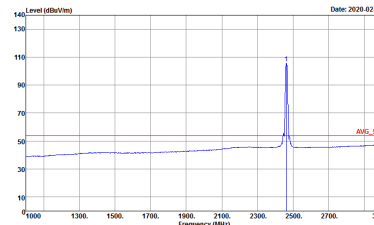

WIFI	2.4GHz 2400~2483.5MHz Band Edge @ 3m	
ANT	802.11b CH11 2462MHz	
1	Horizontal	Fundamental
<p>Peak</p>	 <p>Site : 03CH12-HY Condition : PEAK_BE_74 3m HORN_9120D_1328 HORIZONTAL Detector : Peak Project : 971035-01 Setting : 16</p>	 <p>Site : 03CH12-HY Condition : PEAK_74 3m HORN_9120D_1328 HORIZONTAL Detector : Peak Project : 971035-01 Setting : 16</p>
<p>Avg.</p>	 <p>Site : 03CH12-HY Condition : AVG_BE_54 3m HORN_9120D_1328 HORIZONTAL Detector : Peak Project : 971035-01 Setting : 16</p>	 <p>Site : 03CH12-HY Condition : AVG_54 3m HORN_9120D_1328 HORIZONTAL Detector : Peak Project : 971035-01 Setting : 16</p>

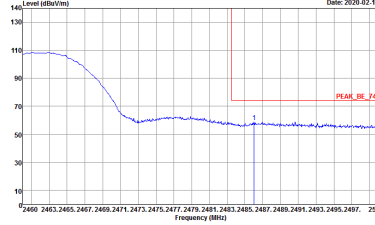
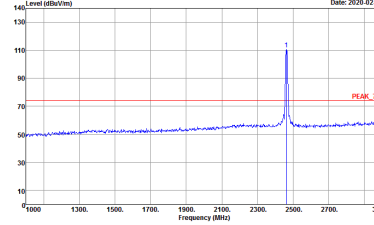
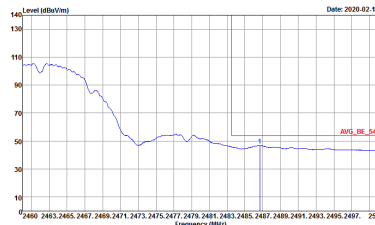
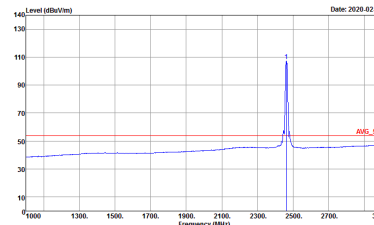

WIFI	2.4GHz 2400~2483.5MHz Band Edge @ 3m	
ANT	802.11b CH11 2462MHz	
1	Vertical	Fundamental
<p>Peak</p>	 <p>Site : 03CH12-HY Condition : PEAK_BE_74 3m HORN_9120D_1328 VERTICAL Detector : Peak Project : 971035-01 Setting : 16</p>	 <p>Site : 03CH12-HY Condition : PEAK_F4 3m HORN_9120D_1328 VERTICAL Detector : Peak Project : 971035-01 Setting : 16</p>
<p>Avg.</p>	 <p>Site : 03CH12-HY Condition : AVG_BE_54 3m HORN_9120D_1328 VERTICAL Detector : Peak Project : 971035-01 Setting : 16</p>	 <p>Site : 03CH12-HY Condition : AVG_F4 3m HORN_9120D_1328 VERTICAL Detector : Peak Project : 971035-01 Setting : 16</p>

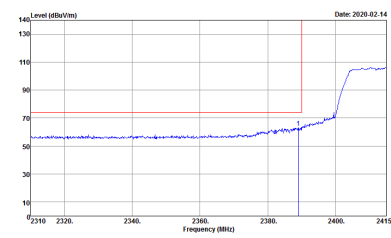
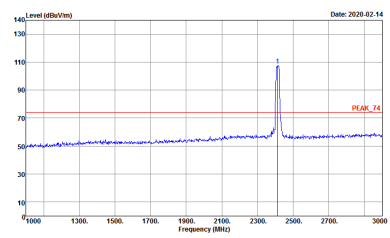
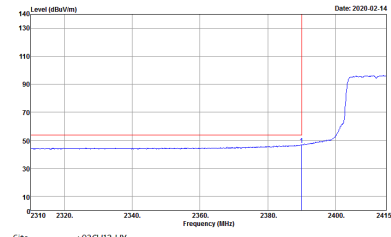
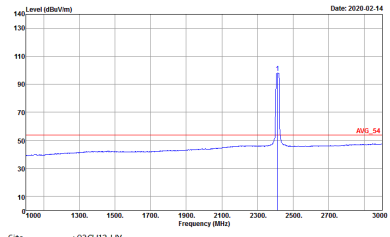

2.4GHz 2400~2483.5MHz
WIFI 802.11g (Band Edge @ 3m)

WIFI	2.4GHz 2400~2483.5MHz Band Edge @ 3m	
ANT	802.11g CH01 2412MHz	
1	Horizontal	Fundamental
Peak	 <p>Site : 03CH12-HY Condition : PEAK_BE_74 3m HORN_91200_1328 HORIZONTAL Detector : Peak Project : 971035-01 Setting : 16</p>	 <p>Site : 03CH12-HY Condition : PEAK_74 3m HORN_91200_1328 HORIZONTAL Detector : Peak Project : 971035-01 Setting : 16</p>
Avg.	 <p>Site : 03CH12-HY Condition : AVG_BE_54 3m HORN_91200_1328 HORIZONTAL Detector : Peak Project : 971035-01 Setting : 16</p>	 <p>Site : 03CH12-HY Condition : AVG_54 3m HORN_91200_1328 HORIZONTAL Detector : Peak Project : 971035-01 Setting : 16</p>

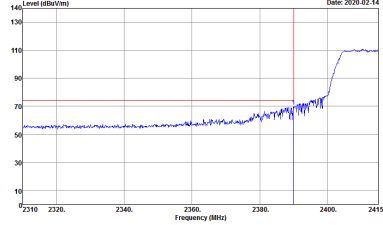
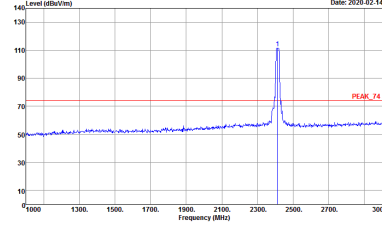
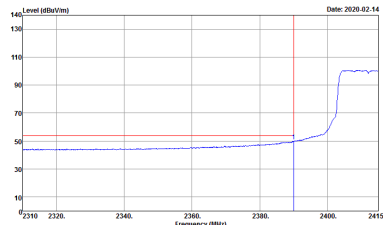
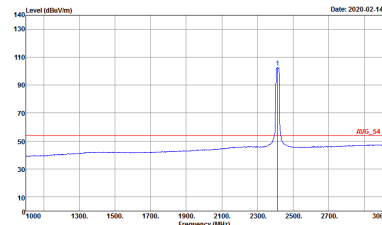

WIFI	2.4GHz 2400~2483.5MHz Band Edge @ 3m	
ANT	802.11g CH01 2412MHz	
1	Vertical	Fundamental
Peak	 <p>Site : 03CH12-HY Condition : PEAK_BE_74 3m HORN_9120D_1328 VERTICAL Detector : Peak Project : 971035-01 Setting : 16</p>	 <p>Site : 03CH12-HY Condition : PEAK_74 3m HORN_9120D_1328 VERTICAL Detector : Peak Project : 971035-01 Setting : 16</p>
Avg.	 <p>Site : 03CH12-HY Condition : AVG_BE_54 3m HORN_9120D_1328 VERTICAL Detector : Peak Project : 971035-01 Setting : 16</p>	 <p>Site : 03CH12-HY Condition : AVG_54 3m HORN_9120D_1328 VERTICAL Detector : Peak Project : 971035-01 Setting : 16</p>

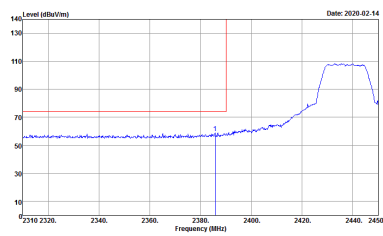
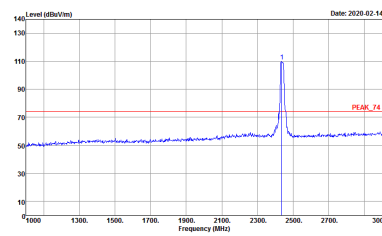
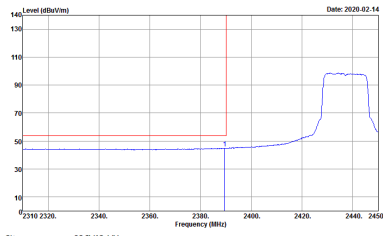
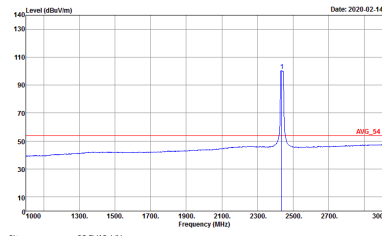

WIFI	2.4GHz 2400~2483.5MHz Band Edge @ 3m	
ANT	802.11g CH06 2437MHz - L	
1	Horizontal	Fundamental
<p>Peak</p>	 <p>Site : 03CH12-HY Condition : PEAK_BE_74 3m HORN_9120D_1328 HORIZONTAL Detector : Peak Project : 971035-01 Setting : 17</p>	 <p>Site : 03CH12-HY Condition : PEAK_F4 3m HORN_9120D_1328 HORIZONTAL Detector : Peak Project : 971035-01 Setting : 17</p>
<p>Avg.</p>	 <p>Site : 03CH12-HY Condition : AVG_BE_54 3m HORN_9120D_1328 HORIZONTAL Detector : Peak Project : 971035-01 Setting : 17</p>	 <p>Site : 03CH12-HY Condition : AVG_F4 3m HORN_9120D_1328 HORIZONTAL Detector : Peak Project : 971035-01 Setting : 17</p>

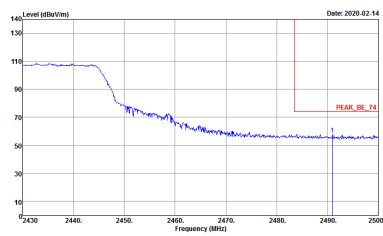
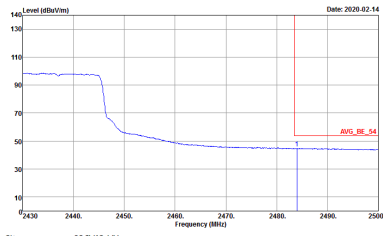

WIFI	2.4GHz 2400~2483.5MHz Band Edge @ 3m	
ANT	802.11g CH06 2437MHz - R	
1	Horizontal	Fundamental
<p>Peak</p>	 <p>Site : 03CH2-HY Condition : PEAK_BE_74 3m HORN_9120D_1328 HORIZONTAL Detector : Peak Project : 971035-01 Setting : 17</p>	<p>Left blank</p>
<p>Avg.</p>	 <p>Site : 03CH2-HY Condition : AVG_BE_54 3m HORN_9120D_1328 HORIZONTAL Detector : Peak Project : 971035-01 Setting : 17</p>	<p>Left blank</p>

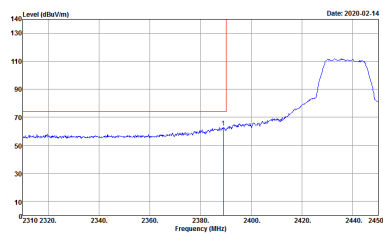
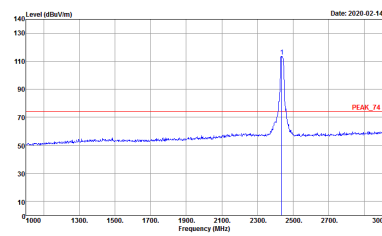
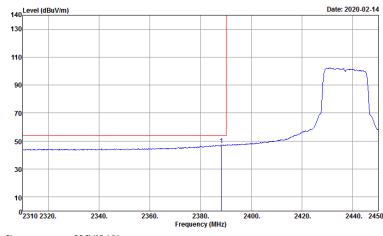
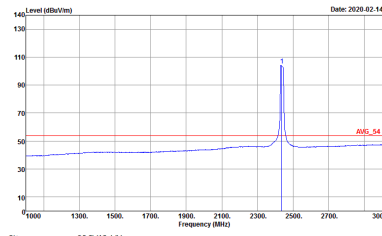

WIFI	2.4GHz 2400~2483.5MHz Band Edge @ 3m	
ANT	802.11g CH06 2437MHz - L	
1	Vertical	Fundamental
<p>Peak</p>	 <p>Site : 03CH2-HY Condition : PEAK_BE_74 3m HORN_9120D_1328 VERTICAL Detector : Peak Project : 971035-01 Setting : 17</p>	 <p>Site : 03CH2-HY Condition : PEAK_74 3m HORN_9120D_1328 VERTICAL Detector : Peak Project : 971035-01 Setting : 17</p>
<p>Avg.</p>	 <p>Site : 03CH2-HY Condition : AVG_BE_54 3m HORN_9120D_1328 VERTICAL Detector : Peak Project : 971035-01 Setting : 17</p>	 <p>Site : 03CH2-HY Condition : AVG_54 3m HORN_9120D_1328 VERTICAL Detector : Peak Project : 971035-01 Setting : 17</p>

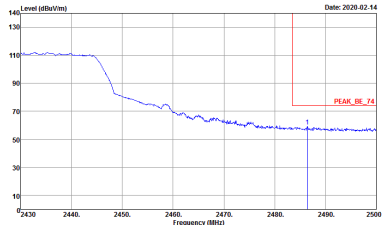
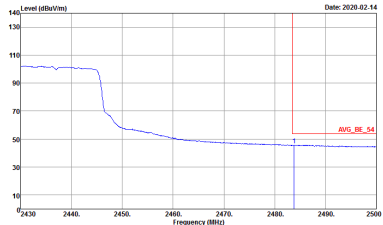

WIFI	2.4GHz 2400~2483.5MHz Band Edge @ 3m	
ANT	802.11g CH06 2437MHz - R	
1	Vertical	Fundamental
<p>Peak</p>	 <p>Site : 03CH2-HY Condition : PEAK_BE_74 3m HORN_9120D_1328 VERTICAL Detector : Peak Project : 971035-01 Setting : 17</p>	<p>Left Blank</p>
<p>Avg.</p>	 <p>Site : 03CH2-HY Condition : AVG_BE_54 3m HORN_9120D_1328 VERTICAL Detector : Peak Project : 971035-01 Setting : 17</p>	<p>Left Blank</p>

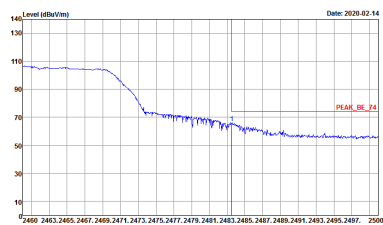
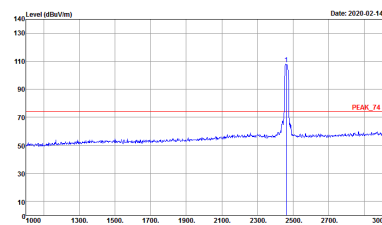
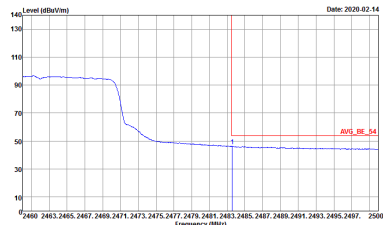
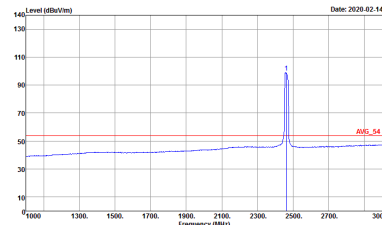

WIFI	2.4GHz 2400~2483.5MHz Band Edge @ 3m	
ANT	802.11g CH11 2462MHz	
1	Horizontal	Fundamental
<p>Peak</p>	 <p>Site : 03CH12-HY Condition : PEAK_BE_74 3m HORN_9120D_1328 HORIZONTAL Detector : Peak Project : 971035-01 Setting : 16</p>	 <p>Site : 03CH12-HY Condition : PEAK_F4 3m HORN_9120D_1328 HORIZONTAL Detector : Peak Project : 971035-01 Setting : 16</p>
<p>Avg.</p>	 <p>Site : 03CH12-HY Condition : AVG_BE_54 3m HORN_9120D_1328 HORIZONTAL Detector : Peak Project : 971035-01 Setting : 16</p>	 <p>Site : 03CH12-HY Condition : AVG_F4 3m HORN_9120D_1328 HORIZONTAL Detector : Peak Project : 971035-01 Setting : 16</p>



WIFI	2.4GHz 2400~2483.5MHz Band Edge @ 3m	
ANT	802.11g CH11 2462MHz	
1	Vertical	Fundamental
Peak	<p>Site : 03CH12-HY Condition : PEAK_BE_74 3m HORN_9120D_1328 VERTICAL Detector : Peak Project : 971035-01 Setting : 16</p>	<p>Site : 03CH12-HY Condition : PEAK_74 3m HORN_9120D_1328 VERTICAL Detector : Peak Project : 971035-01 Setting : 16</p>
	<p>Site : 03CH12-HY Condition : AVG_BE_54 3m HORN_9120D_1328 VERTICAL Detector : Peak Project : 971035-01 Setting : 16</p>	<p>Site : 03CH12-HY Condition : AVG_54 3m HORN_9120D_1328 VERTICAL Detector : Peak Project : 971035-01 Setting : 16</p>

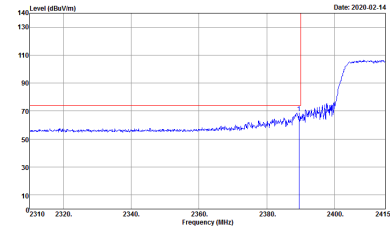
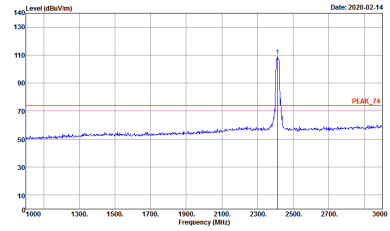
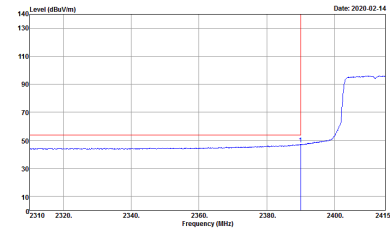
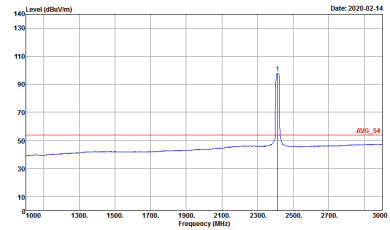

2.4GHz 2400~2483.5MHz
WIFI 802.11n HT20 (Band Edge @ 3m)

WIFI	2.4GHz 2400~2483.5MHz Band Edge @ 3m	
ANT	802.11n HT20 CH01 2412MHz	
1	Horizontal	Fundamental
Peak	 <p>Site : 03CH12-HY Condition : PEAK_BE_74 3m HORN_91200_1328 HORIZONTAL Detector : Peak Project : 971035-01 Setting : 16</p>	 <p>Site : 03CH12-HY Condition : PEAK_74 3m HORN_91200_1328 HORIZONTAL Detector : Peak Project : 971035-01 Setting : 16</p>
Avg.	 <p>Site : 03CH12-HY Condition : AVG_BE_54 3m HORN_91200_1328 HORIZONTAL Detector : Peak Project : 971035-01 Setting : 16</p>	 <p>Site : 03CH12-HY Condition : AVG_54 3m HORN_91200_1328 HORIZONTAL Detector : Peak Project : 971035-01 Setting : 16</p>



WIFI	2.4GHz 2400~2483.5MHz Band Edge @ 3m	
ANT	802.11n HT20 CH01 2412MHz	
1	Vertical	Fundamental
Peak	<p>Site : 03CH12-HY Condition : PEAK_BE_74 3m HORN_9120D_1328 VERTICAL RBW:1000.000kHz VBW:3000.000kHz SWT:Auto Detector : Peak Project : 971035-01 Setting : 16</p>	<p>Site : 03CH12-HY Condition : PEAK_74 3m HORN_9120D_1328 VERTICAL RBW:1000.000kHz VBW:3000.000kHz SWT:Auto Detector : Peak Project : 971035-01 Setting : 16</p>
Avg.	<p>Site : 03CH12-HY Condition : AVG_BE_54 3m HORN_9120D_1328 VERTICAL RBW:1000.000kHz VBW:1.000kHz SWT:Auto Detector : Peak Project : 971035-01 Setting : 16</p>	<p>Site : 03CH12-HY Condition : AVG_54 3m HORN_9120D_1328 VERTICAL RBW:1000.000kHz VBW:1.000kHz SWT:Auto Detector : Peak Project : 971035-01 Setting : 16</p>

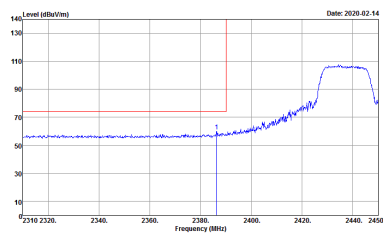
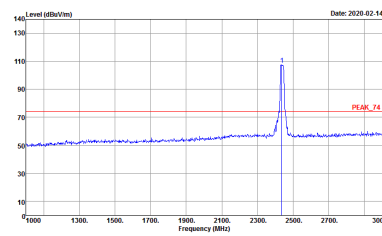
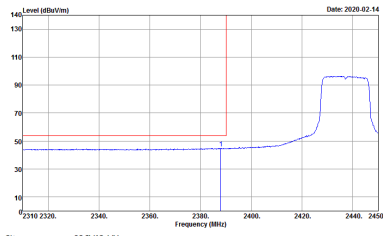
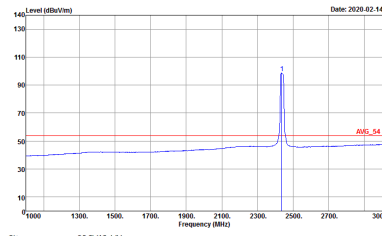

WIFI	2.4GHz 2400~2483.5MHz Band Edge @ 3m	
ANT	802.11n HT20 CH06 2437MHz - L	
1	Horizontal	Fundamental
<p>Peak</p>	 <p>Site : 03CH12-HY Condition : PEAK_BE_74 3m HORN_9120D_1328 HORIZONTAL Detector : Peak Project : 971035-01 Setting : 17</p>	 <p>Site : 03CH12-HY Condition : PEAK_74 3m HORN_9120D_1328 HORIZONTAL Detector : Peak Project : 971035-01 Setting : 17</p>
<p>Avg.</p>	 <p>Site : 03CH12-HY Condition : AVG_BE_54 3m HORN_9120D_1328 HORIZONTAL Detector : Peak Project : 971035-01 Setting : 17</p>	 <p>Site : 03CH12-HY Condition : AVG_54 3m HORN_9120D_1328 HORIZONTAL Detector : Peak Project : 971035-01 Setting : 17</p>

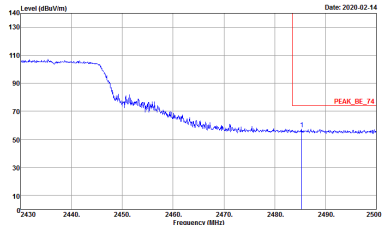
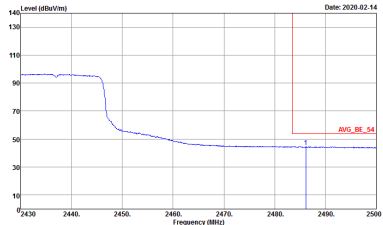

WIFI	2.4GHz 2400~2483.5MHz Band Edge @ 3m	
ANT	802.11n HT20 CH06 2437MHz - R	
1	Horizontal	Fundamental
<p>Peak</p>	 <p>Site : 03CH2-HY Condition : PEAK_BE_74 3m HORN_9120D_1328 HORIZONTAL Detector : Peak Project : 971035-01 Setting : 17</p>	<p>Left blank</p>
<p>Avg.</p>	 <p>Site : 03CH2-HY Condition : AVG_BE_54 3m HORN_9120D_1328 HORIZONTAL Detector : Peak Project : 971035-01 Setting : 17</p>	<p>Left blank</p>

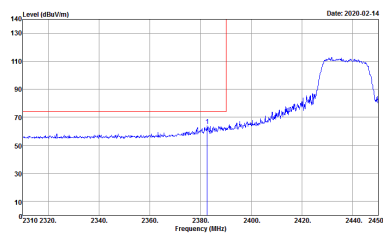
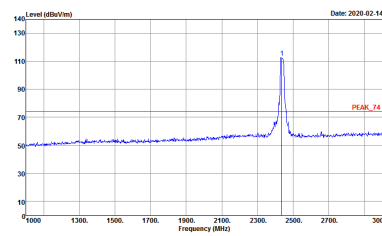
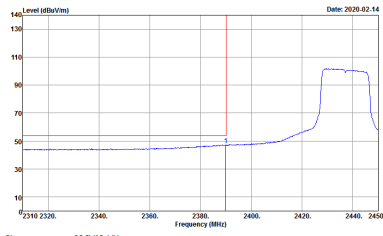
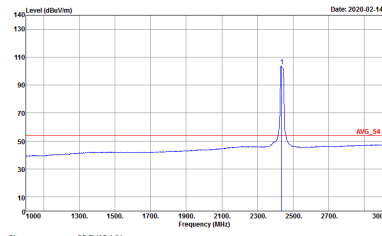

WIFI	2.4GHz 2400~2483.5MHz Band Edge @ 3m	
ANT	802.11n HT20 CH06 2437MHz - L	
1	Vertical	Fundamental
Peak	 <p>Site : 03CH12-HY Condition : PEAK_BE_74 3m HORN_9120D_1328 VERTICAL RBW:1000.000kHz VBW:3000.000kHz SWT:Auto Detector : Peak Project : 971035-01 Setting : 17</p>	 <p>Site : 03CH12-HY Condition : PEAK_74 3m HORN_9120D_1328 VERTICAL RBW:1000.000kHz VBW:3000.000kHz SWT:Auto Detector : Peak Project : 971035-01 Setting : 17</p>
Avg.	 <p>Site : 03CH12-HY Condition : AVG_BE_54 3m HORN_9120D_1328 VERTICAL RBW:1000.000kHz VBW:1.000kHz SWT:Auto Detector : Peak Project : 971035-01 Setting : 17</p>	 <p>Site : 03CH12-HY Condition : AVG_54 3m HORN_9120D_1328 VERTICAL RBW:1000.000kHz VBW:1.000kHz SWT:Auto Detector : Peak Project : 971035-01 Setting : 17</p>

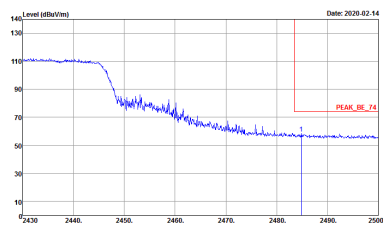
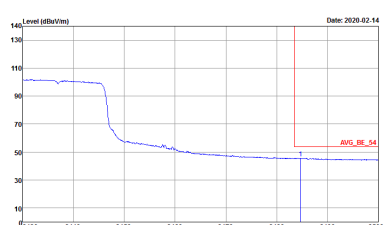

WIFI	2.4GHz 2400~2483.5MHz Band Edge @ 3m	
ANT	802.11n HT20 CH06 2437MHz - R	
1	Vertical	Fundamental
<p>Peak</p>	 <p>Site : 03CH2-HY Condition : PEAK_BE_74 3m HORN_9120D_1328 VERTICAL Detector : Peak Project : 971035-01 Setting : 17</p>	<p>Left Blank</p>
<p>Avg.</p>	 <p>Site : 03CH2-HY Condition : AVG_BE_54 3m HORN_9120D_1328 VERTICAL Detector : Peak Project : 971035-01 Setting : 17</p>	<p>Left Blank</p>

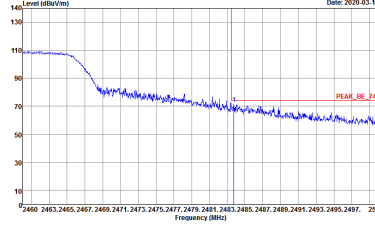
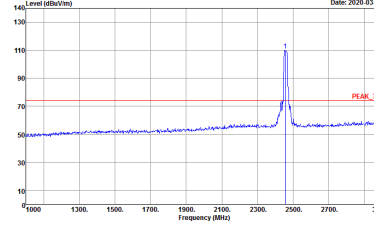
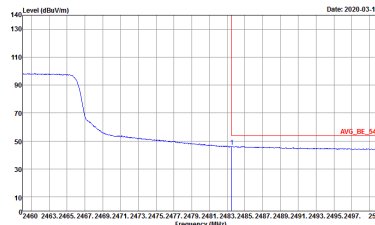
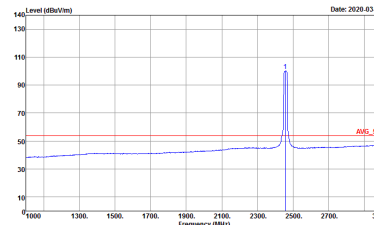

WIFI	2.4GHz 2400~2483.5MHz Band Edge @ 3m	
ANT	802.11n HT20 CH10 2457MHz	
1	Horizontal	Fundamental
<p>Peak</p>	 <p>Site : 03CH12-HY Condition : PEAK_BE_74 3m HORN_9120D_1328 HORIZONTAL Detector : Peak Project : 971035-01 Setting : 16</p>	 <p>Site : 03CH12-HY Condition : PEAK_74 3m HORN_9120D_1328 HORIZONTAL Detector : Peak Project : 971035-01 Setting : 16</p>
<p>Avg.</p>	 <p>Site : 03CH12-HY Condition : AVG_BE_54 3m HORN_9120D_1328 HORIZONTAL Detector : Peak Project : 971035-01 Setting : 16</p>	 <p>Site : 03CH12-HY Condition : AVG_54 3m HORN_9120D_1328 HORIZONTAL Detector : Peak Project : 971035-01 Setting : 16</p>

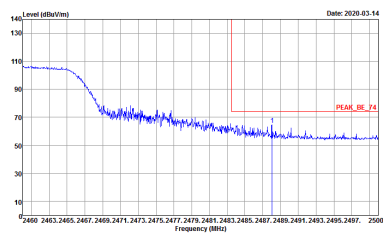
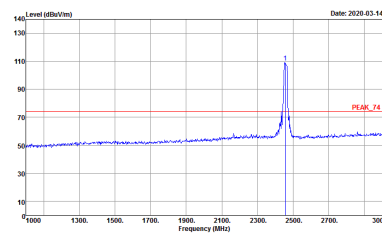
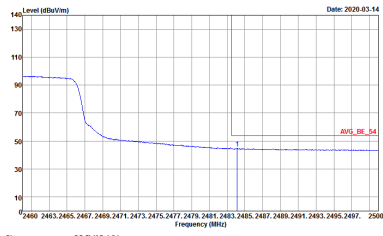
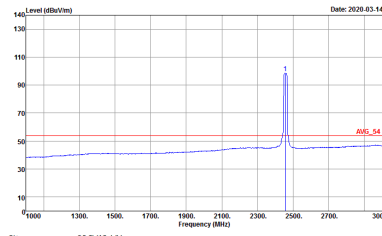

WIFI	2.4GHz 2400~2483.5MHz Fundamental @ 3m	
ANT	802.11n HT20 CH10 2457MHz	
1	Vertical	Fundamental
<p>Peak</p>	 <p>Site : 03CH12-HY Condition : PEAK_BE_74 3m HORN_9120D_1328 VERTICAL Detector : Peak Project : 971035-01 Setting : 16</p>	 <p>Site : 03CH12-HY Condition : PEAK_74 3m HORN_9120D_1328 VERTICAL Detector : Peak Project : 971035-01 Setting : 16</p>
<p>Avg.</p>	 <p>Site : 03CH12-HY Condition : AVG_BE_54 3m HORN_9120D_1328 VERTICAL Detector : Peak Project : 971035-01 Setting : 16</p>	 <p>Site : 03CH12-HY Condition : AVG_54 3m HORN_9120D_1328 VERTICAL Detector : Peak Project : 971035-01 Setting : 16</p>

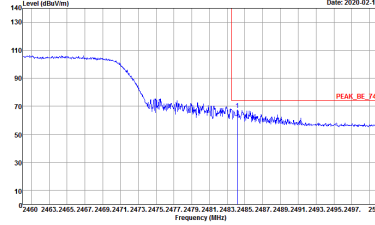
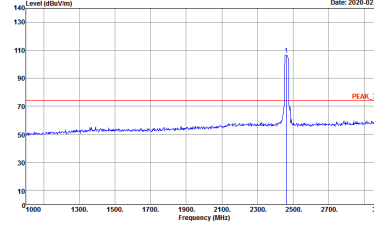
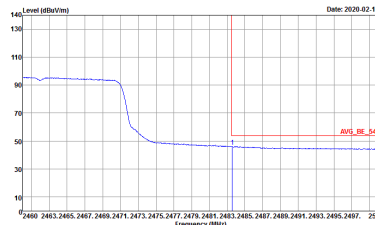
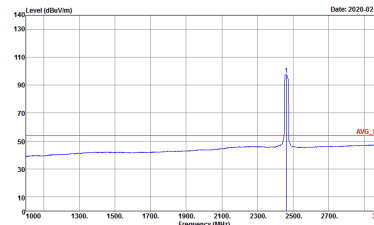

WIFI	2.4GHz 2400~2483.5MHz Band Edge @ 3m	
ANT	802.11n HT20 CH11 2462MHz	
1	Horizontal	Fundamental
<p>Peak</p>	 <p>Site : 03CH12-HY Condition : PEAK_BE_74 3m HORN_9120D_1328 HORIZONTAL Detector : Peak Project : 971035-01 Setting : 15</p>	 <p>Site : 03CH12-HY Condition : PEAK_F4 3m HORN_9120D_1328 HORIZONTAL Detector : Peak Project : 971035-01 Setting : 15</p>
<p>Avg.</p>	 <p>Site : 03CH12-HY Condition : AVG_BE_54 3m HORN_9120D_1328 HORIZONTAL Detector : Peak Project : 971035-01 Setting : 15</p>	 <p>Site : 03CH12-HY Condition : AVG_F4 3m HORN_9120D_1328 HORIZONTAL Detector : Peak Project : 971035-01 Setting : 15</p>

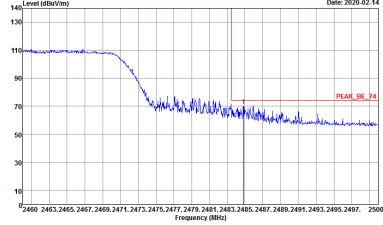
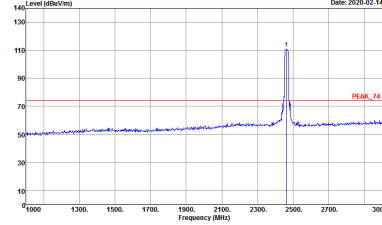
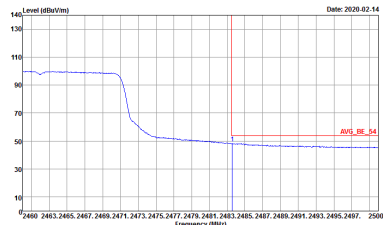
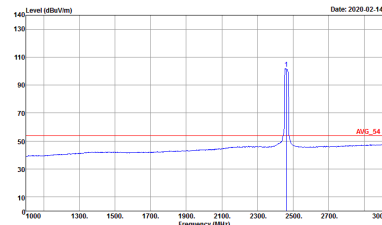

WIFI	2.4GHz 2400~2483.5MHz Fundamental @ 3m	
ANT	802.11n HT20 CH11 2462MHz	
1	Vertical	Fundamental
<p>Peak</p>	 <p>Site : 03CH12-HY Condition : PEAK_BE_74 3m HORN_9120D_1328 VERTICAL Detector : Peak Project : 971035-01 Setting : 15</p>	 <p>Site : 03CH12-HY Condition : PEAK_74 3m HORN_9120D_1328 VERTICAL Detector : Peak Project : 971035-01 Setting : 15</p>
<p>Avg.</p>	 <p>Site : 03CH12-HY Condition : AVG_BE_54 3m HORN_9120D_1328 VERTICAL Detector : Peak Project : 971035-01 Setting : 15</p>	 <p>Site : 03CH12-HY Condition : AVG_54 3m HORN_9120D_1328 VERTICAL Detector : Peak Project : 971035-01 Setting : 15</p>



2.4GHz 2400~2483.5MHz
WIFI 802.11b (Harmonic @ 3m)

WIFI	2.4GHz 2400~2483.5MHz Harmonic @ 3m	
ANT	802.11b CH01 2412MHz	
1	Horizontal	Vertical
Peak Avg.	<p>Site : 03CH12-HY Condition : PEAK_74 3m HORN_91200_1328 HORIZONTAL Detector : Peak Project : 971035-01 Setting : 17</p>	<p>Site : 03CH12-HY Condition : PEAK_74 3m HORN_91200_1328 VERTICAL Detector : Peak Project : 971035-01 Setting : 17</p>

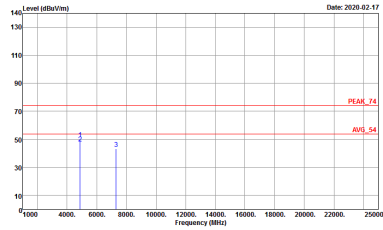
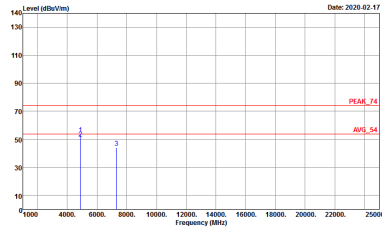

WIFI	2.4GHz 2400~2483.5MHz Harmonic @ 3m	
ANT	802.11b CH06 2437MHz	
1	Horizontal	Vertical
Peak Avg.	 <p>Site : 03CH12-HY Condition : PEAK_74 3m HORN_91200_1328 HORIZONTAL Detector : Peak Project : 971035-01 Setting : 17</p>	 <p>Site : 03CH12-HY Condition : PEAK_74 3m HORN_91200_1328 VERTICAL Detector : Peak Project : 971035-01 Setting : 17</p>

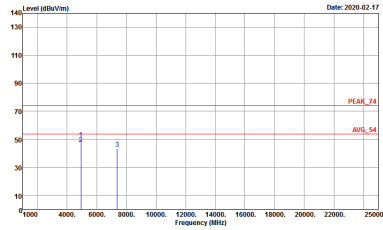
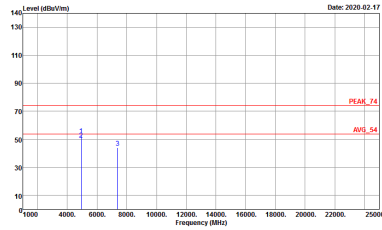

WIFI	2.4GHz 2400~2483.5MHz Harmonic @ 3m	
ANT	802.11b CH11 2462MHz	
1	Horizontal	Vertical
Peak Avg.	 <p>Site : 03CH12-HY Condition : PEAK_74 3m HORN_91200_1328 HORIZONTAL Detector : Peak Project : 971035-01 Setting : 16</p>	 <p>Site : 03CH12-HY Condition : PEAK_74 3m HORN_91200_1328 VERTICAL Detector : Peak Project : 971035-01 Setting : 16</p>



2.4GHz 2400~2483.5MHz
WIFI 802.11g (Harmonic @ 3m)

WIFI	2.4GHz 2400~2483.5MHz Harmonic @ 3m	
ANT	802.11g CH01 2412MHz	
1	Horizontal	Vertical
Peak Avg.	<p>Site : 03CH12-HY Condition : PEAK_74 3m HORN_91200_1328 HORIZONTAL Detector : Peak Project : 971035-01 Setting : 16</p>	<p>Site : 03CH12-HY Condition : PEAK_74 3m HORN_91200_1328 VERTICAL Detector : Peak Project : 971035-01 Setting : 16</p>

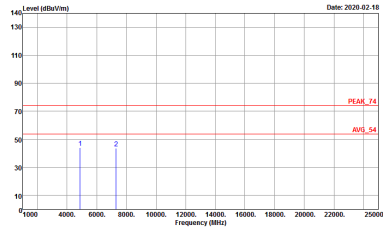
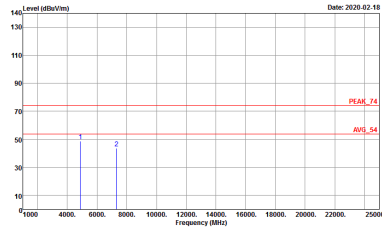

WIFI	2.4GHz 2400~2483.5MHz Harmonic @ 3m	
ANT	802.11g CH06 2437MHz	
1	Horizontal	Vertical
Peak Avg.	 <p>Site : 03CH12-HY Condition : PEAK_74 3m HORN_91200_1328 HORIZONTAL Detector : Peak Project : 971035-01 Setting : 17</p>	 <p>Site : 03CH12-HY Condition : PEAK_74 3m HORN_91200_1328 VERTICAL Detector : Peak Project : 971035-01 Setting : 17</p>

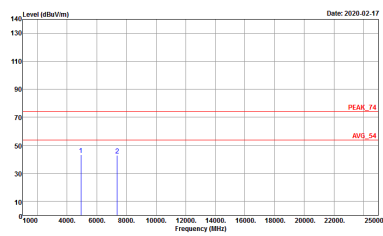
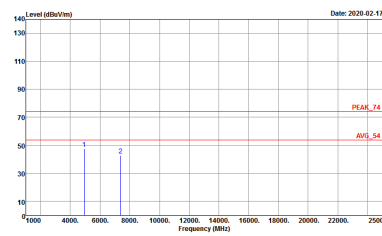

WIFI	2.4GHz 2400~2483.5MHz Harmonic @ 3m	
ANT	802.11g CH11 2462MHz	
1	Horizontal	Vertical
Peak Avg.	 <p>Site : 03CH12-HY Condition : PEAK_74 3m HORN_91200_1328 HORIZONTAL Detector : Peak Project : 971035-01 Setting : 16</p>	 <p>Site : 03CH12-HY Condition : PEAK_74 3m HORN_91200_1328 VERTICAL Detector : Peak Project : 971035-01 Setting : 16</p>



2.4GHz 2400~2483.5MHz
WIFI 802.11n HT20 (Harmonic @ 3m)

WIFI	2.4GHz 2400~2483.5MHz Harmonic @ 3m	
ANT	802.11n HT20 CH01 2412MHz	
1	Horizontal	Vertical
Peak Avg.	<p>Site : 03CH12-HY Condition : PEAK_74 3m HORN_91200_1328 HORIZONTAL Detector : Peak Project : 971035-01 Setting : 16</p>	<p>Site : 03CH12-HY Condition : PEAK_74 3m HORN_91200_1328 VERTICAL Detector : Peak Project : 971035-01 Setting : 16</p>

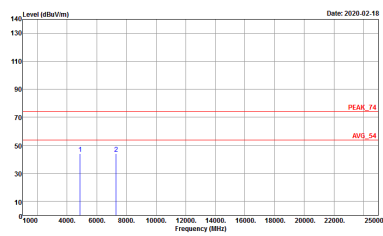
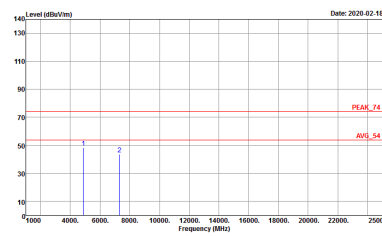

WIFI	2.4GHz 2400~2483.5MHz Harmonic @ 3m	
ANT	802.11n HT20 CH06 2437MHz	
1	Horizontal	Vertical
Peak Avg.	 <p>Site : 03CH12-HY Condition : PEAK_74 3m HORN_91200_1328 HORIZONTAL Detector : Peak Project : 971035-01 Setting : 17</p>	 <p>Site : 03CH12-HY Condition : PEAK_74 3m HORN_91200_1328 VERTICAL Detector : Peak Project : 971035-01 Setting : 17</p>

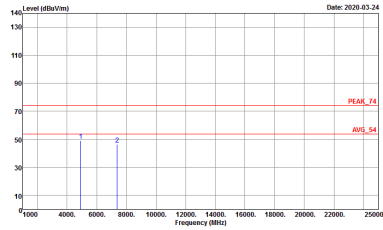
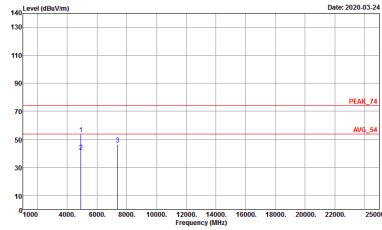

WIFI	2.4GHz 2400~2483.5MHz Harmonic @ 3m	
ANT	802.11n HT20 CH10 2457MHz	
1	Horizontal	Vertical
Peak Avg.	 <p>Site : 03CH12-HY Condition : PEAK_74 3m HORN_91200_1328 HORIZONTAL Detector : Peak Project : 971035-01 Setting : 16</p>	 <p>Site : 03CH12-HY Condition : PEAK_74 3m HORN_91200_1328 VERTICAL Detector : Peak Project : 971035-01 Setting : 16</p>

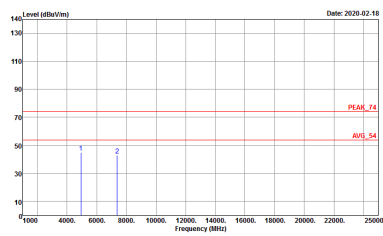
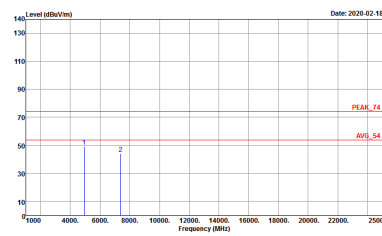

WIFI	2.4GHz 2400~2483.5MHz Harmonic @ 3m	
ANT	802.11n HT20 CH11 2462MHz	
1	Horizontal	Vertical
Peak Avg.	 <p>Site : 03CH12-HY Condition : PEAK_74 3m HORN_91200_1328 HORIZONTAL Detector : Peak Project : 971035-01 Setting : 15</p>	 <p>Site : 03CH12-HY Condition : PEAK_74 3m HORN_91200_1328 VERTICAL Detector : Peak Project : 971035-01 Setting : 15</p>



Emission below 1GHz
2.4GHz WIFI 802.11b (LF)

Table with 3 columns: WIFI (2.4GHz 2400~2483.5MHz), ANT (802.11b LF), and 1 (Horizontal/Vertical). It contains two spectral plots: Horizontal and Vertical, both showing Level (dBuV/m) vs Frequency (MHz) with a 'QP / Peak' label.



Appendix E. Duty Cycle Plots

Band	Duty Cycle(%)	T(us)	1/T(kHz)	VBW Setting	Duty Factor(dB)
802.11b	98.91	-	-	10Hz	0.05
802.11g	93.49	1435	0.70	1kHz	0.29
2.4GHz 802.11n HT20	92.10	1340	0.75	1kHz	0.36

802.11b

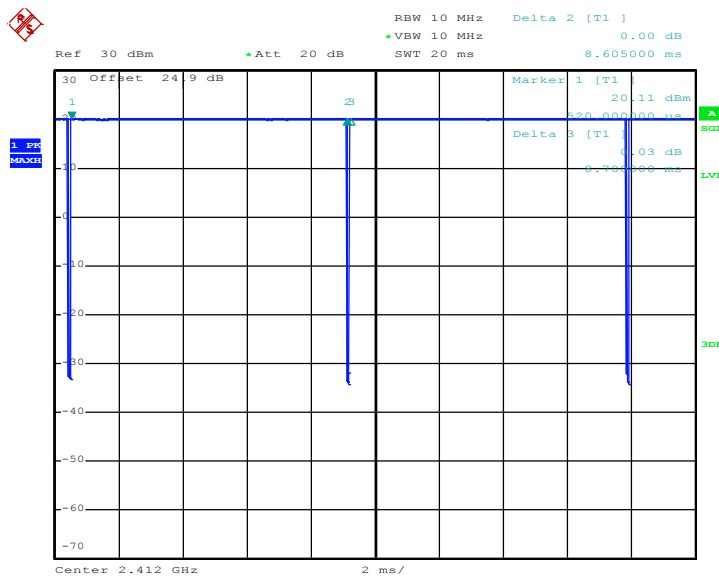



802.11g

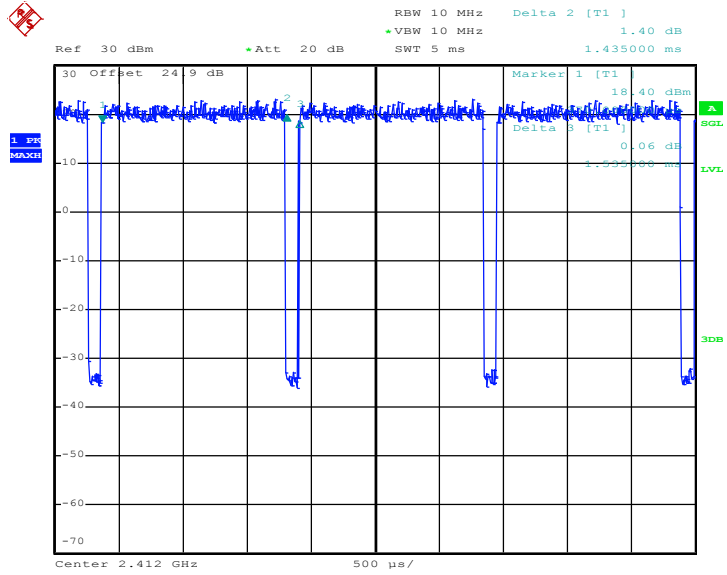

802.11n HT20

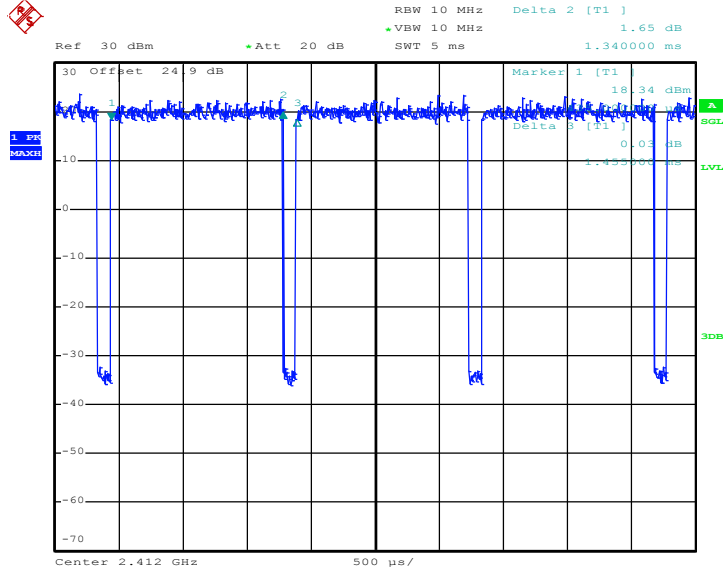

— THE END —