

LTE B14 10MHz QPSK Middle Channel RB50-0 ID:27979

Intentionally Blank

5G NR n14 EMISSION MASK

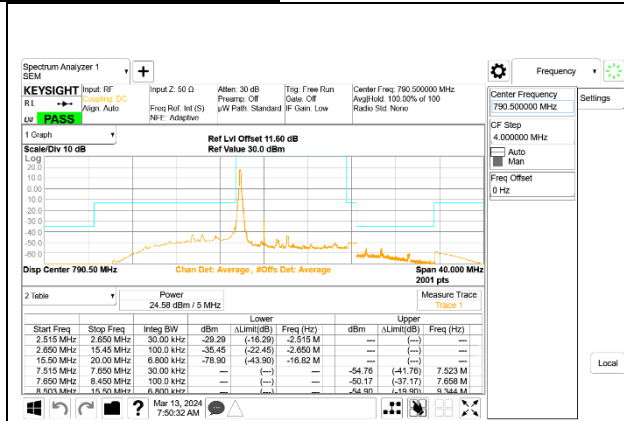

5G NR n14 5MHz BPSK Low Channel RB1-0, ID:28498

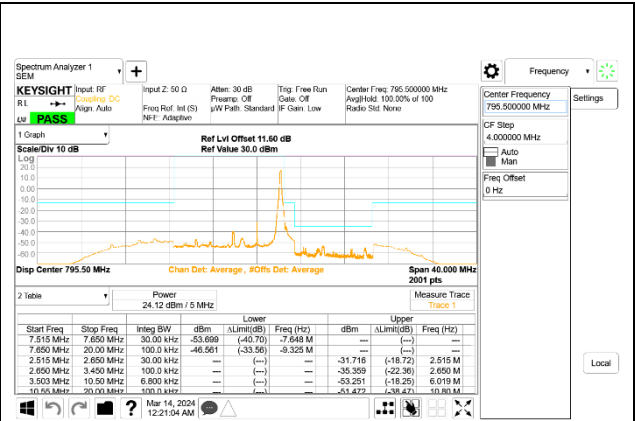

5G NR n14 5MHz BPSK High Channel RB1-24, ID:28498

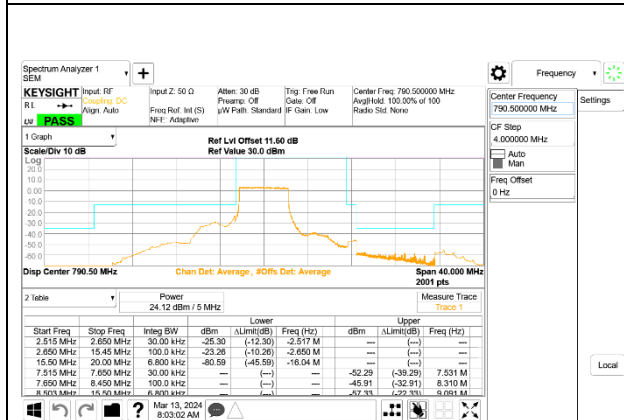

5G NR n14 5MHz BPSK Low Channel RB25-0, ID:28498

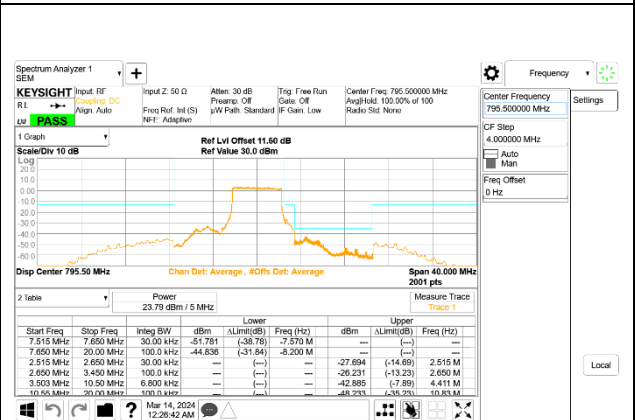

5G NR n14 5MHz BPSK High Channel RB25-0, ID:28498

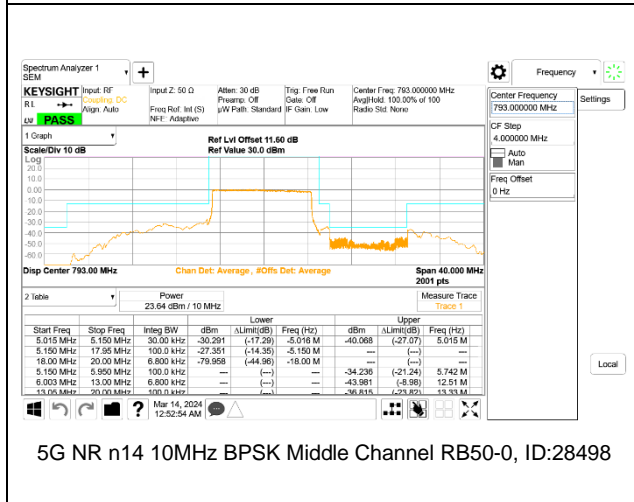
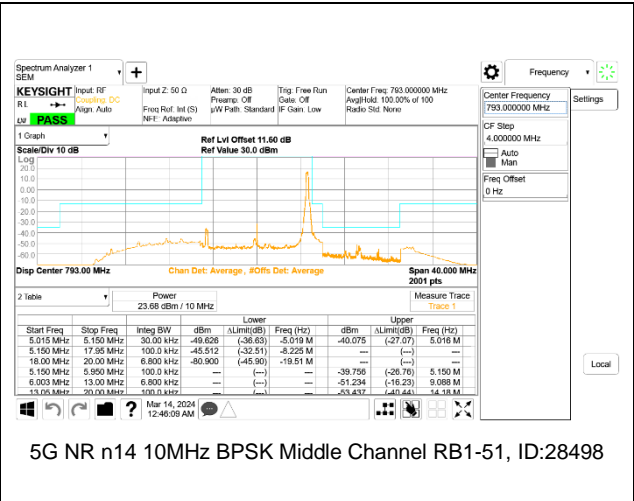
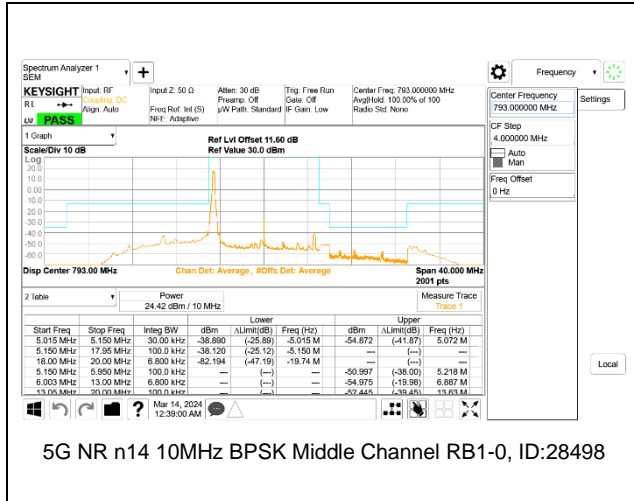

Intentionally Blank

9.2.6. LTE BAND 17

LIMITS

FCC: §27.53

(g) For operations in the 600 MHz band and the 698-746 MHz band, the power of any emission outside a licensee's frequency band(s) of operation shall be attenuated below the transmitter power (P) within the licensed band(s) of operation, measured in watts, by at least $43 + 10 \log (P)$ dB. Compliance with this provision is based on the use of measurement instrumentation employing a resolution bandwidth of 100 kilohertz or greater. However, in the 100 kilohertz bands immediately outside and adjacent to a licensee's frequency block, a resolution bandwidth of at least 30 kHz may be employed.

LTE BAND 17 EMISSION MASK

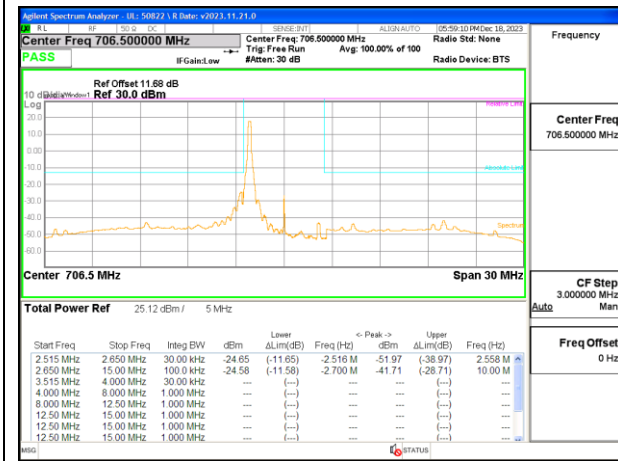

LTE B17 5MHz QPSK Low Channel RB1-0

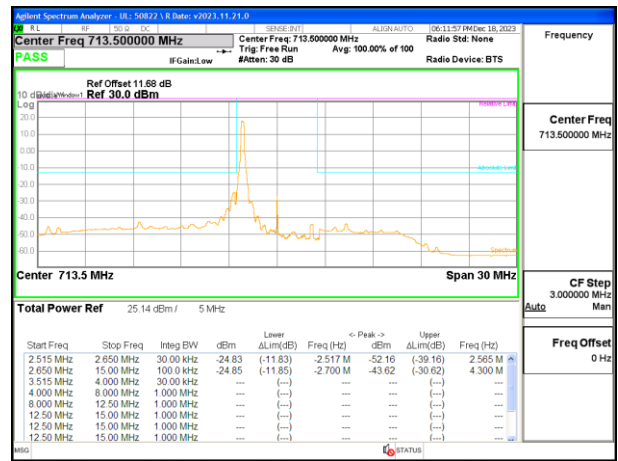

LTE B17 5MHz QPSK High Channel RB1-0

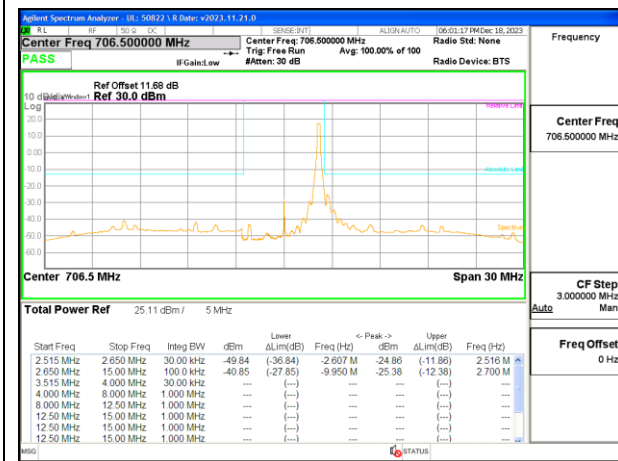

LTE B17 5MHz QPSK Low Channel RB1-24

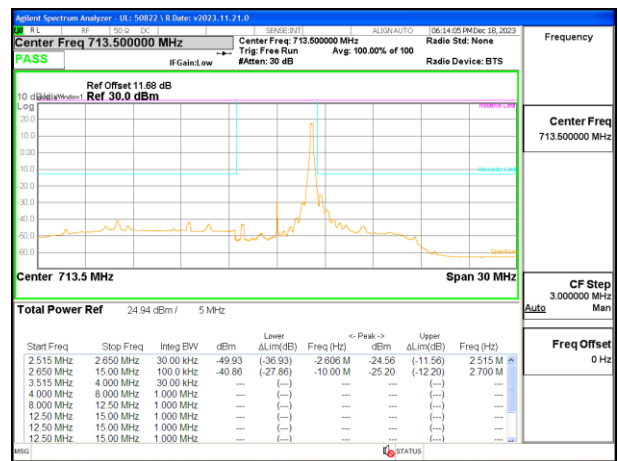

LTE B17 5MHz QPSK High Channel RB1-24

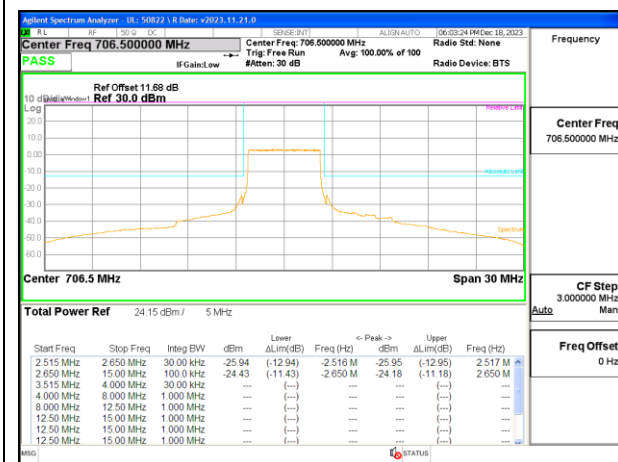

LTE B17 5MHz QPSK Low Channel RB25-0

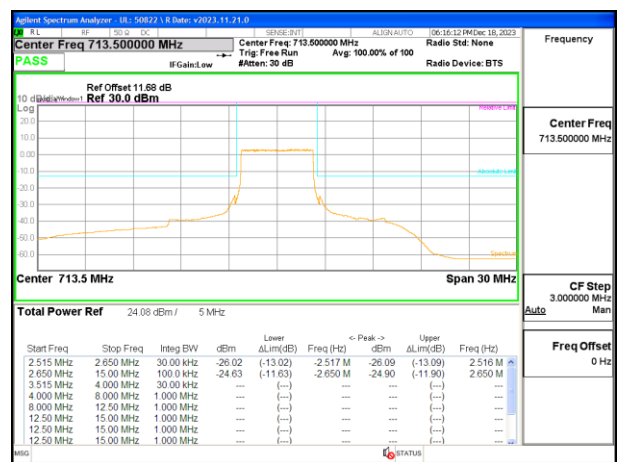

LTE B17 5MHz QPSK High Channel RB25-0

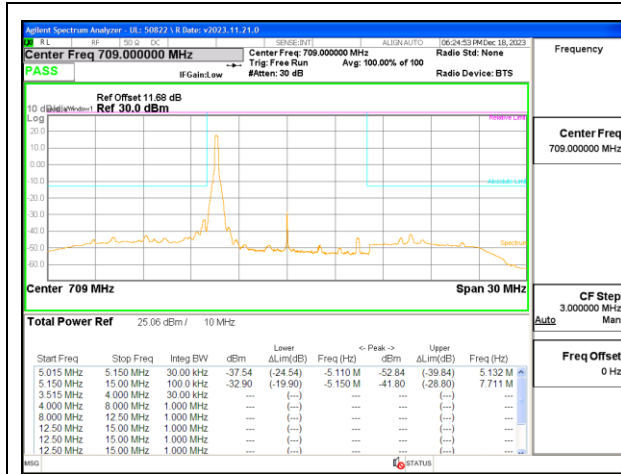

LTE B17 10MHz QPSK Low Channel RB1-0



LTE B17 5MHz QPSK High Channel RB25-0

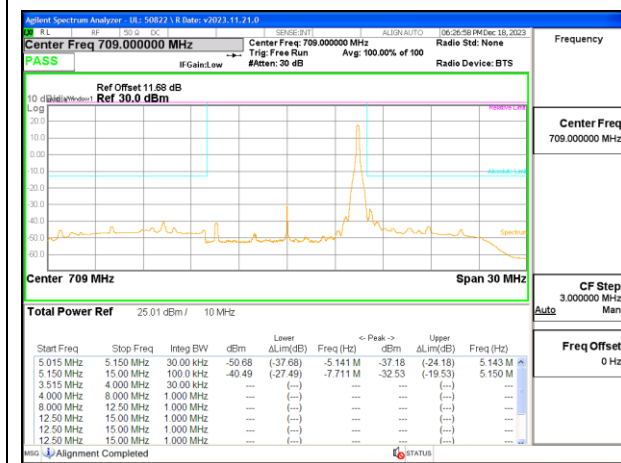

LTE B17 10MHz QPSK Low Channel RB1-49

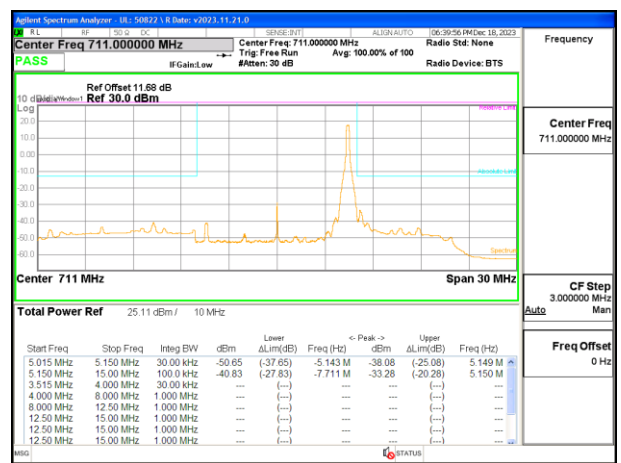

LTE B17 10MHz QPSK High Channel RB1-49

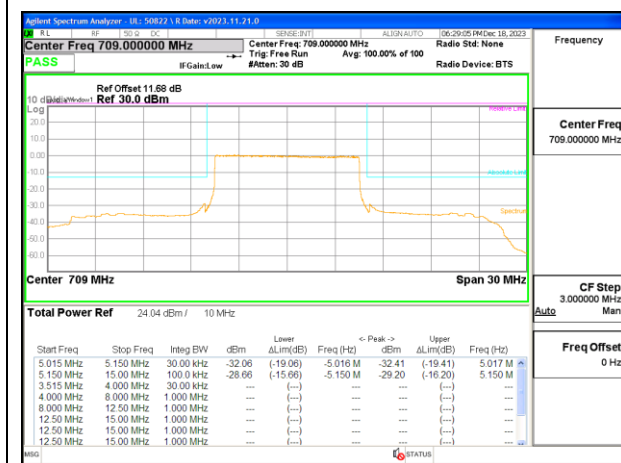

LTE B17 10MHz QPSK Low Channel RB50-0

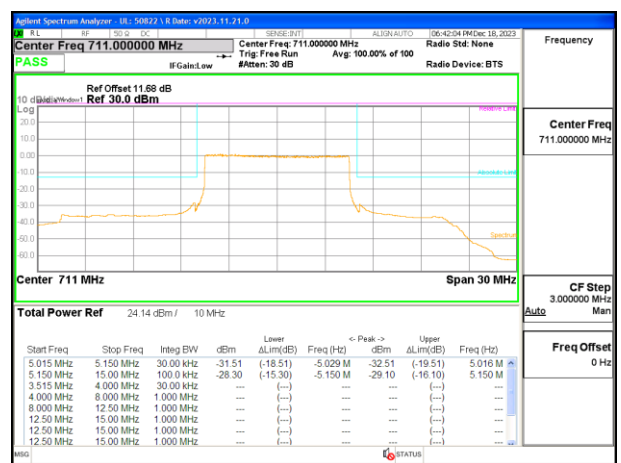

LTE B17 10MHz QPSK High Channel RB50-0

9.2.7. LTE BAND 25 AND 5G NR n25

LIMITS

FCC: §24.238 (a)

The power of any emission outside of the authorized operating frequency ranges must be attenuated below the transmitting power (P) by a factor of at least $43 + 10 \log (P)$ dB.

LTE BAND 25 BANDEDGE

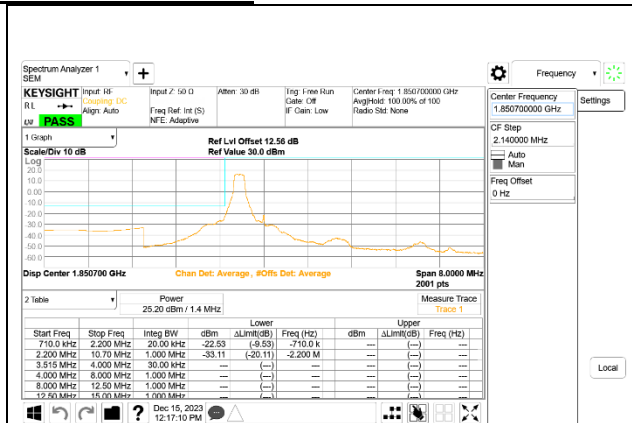

LTE B25 1.4MHz QPSK Low Channel RB1-0, ID:50822

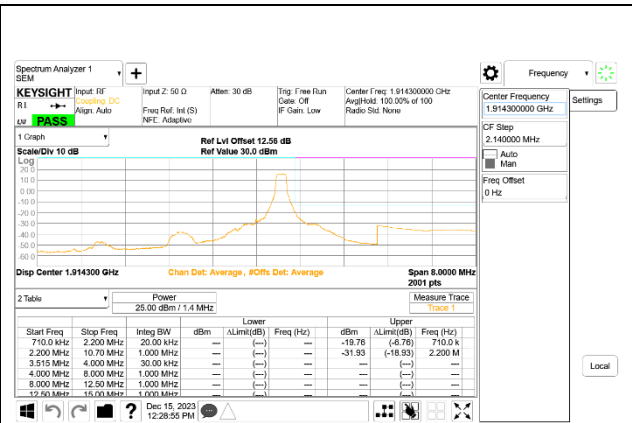

LTE B25 1.4MHz QPSK High Channel RB1-5, ID:50822

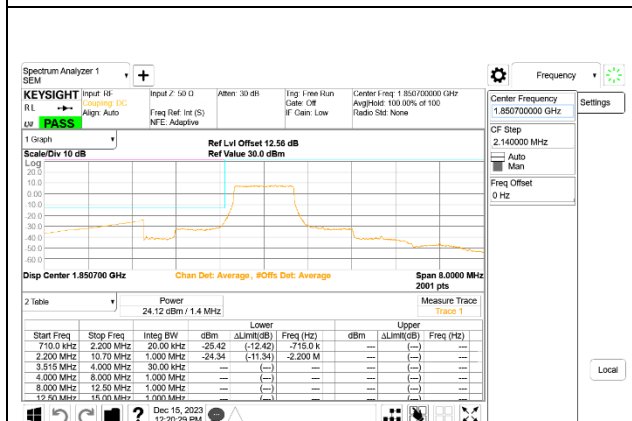

LTE B25 1.4MHz QPSK Low Channel RB6-0 ID:50822

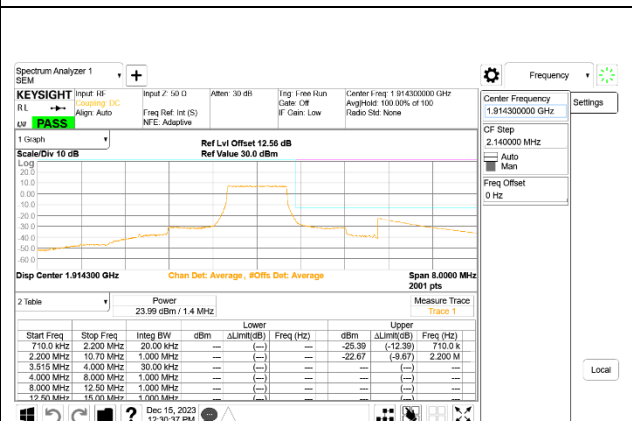

LTE B25 1.4MHz QPSK High Channel RB6-0 ID:50822

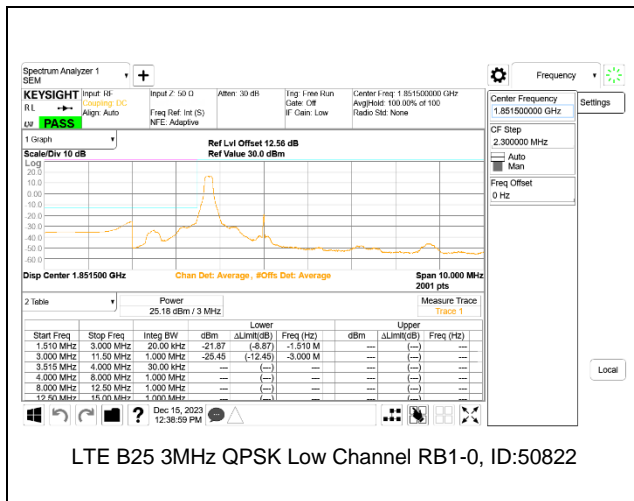

LTE B25 3MHz QPSK Low Channel RB1-0, ID:50822

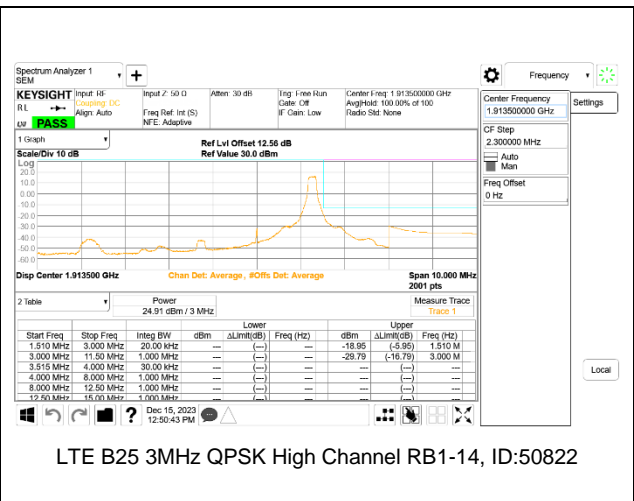

LTE B25 3MHz QPSK High Channel RB1-14, ID:50822

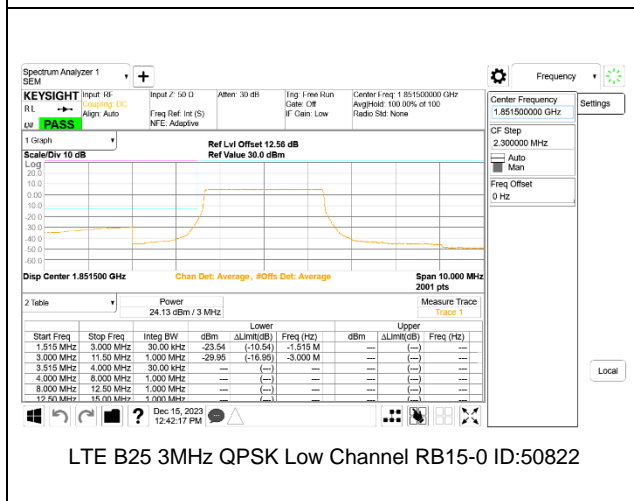

LTE B25 3MHz QPSK Low Channel RB15-0 ID:50822

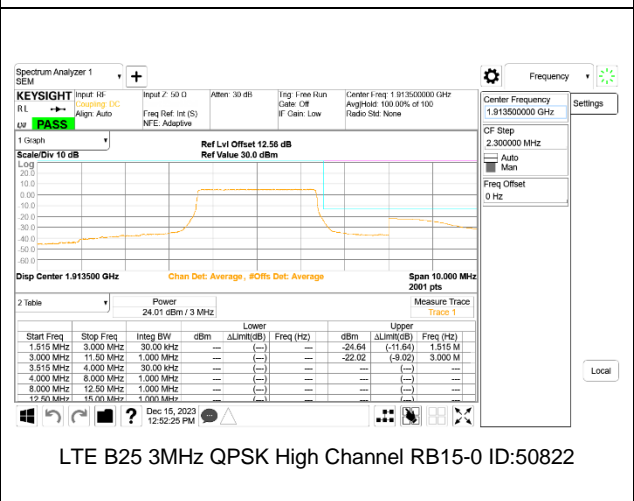

LTE B25 3MHz QPSK High Channel RB15-0 ID:50822

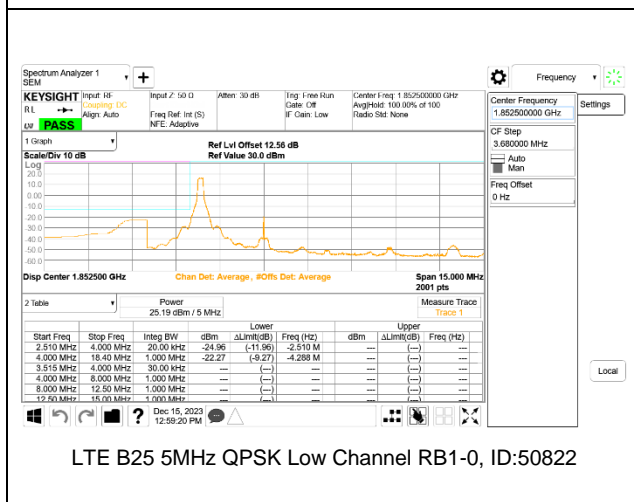

LTE B25 5MHz QPSK Low Channel RB1-0, ID:50822

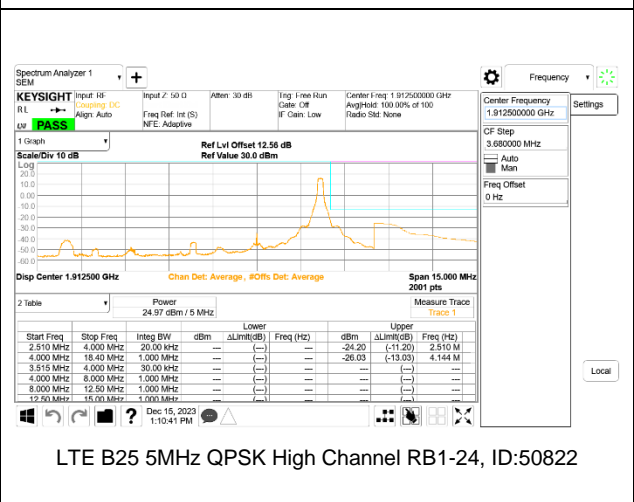

LTE B25 5MHz QPSK High Channel RB1-24, ID:50822

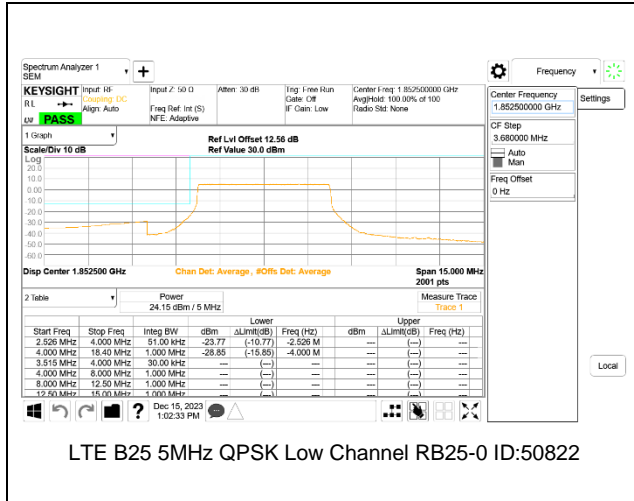

LTE B25 5MHz QPSK Low Channel RB25-0 ID:50822

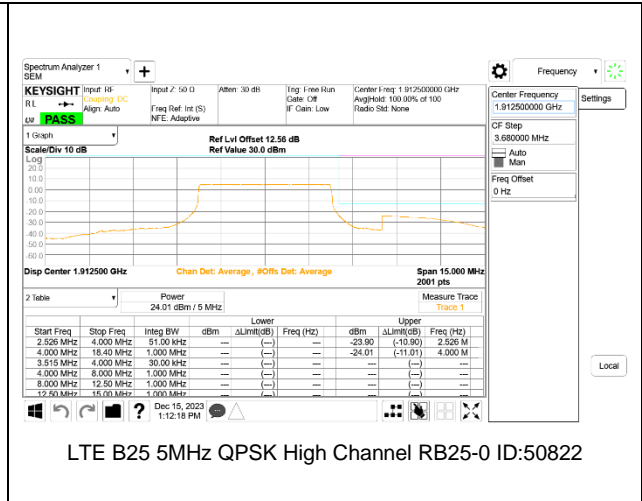

LTE B25 5MHz QPSK High Channel RB25-0 ID:50822

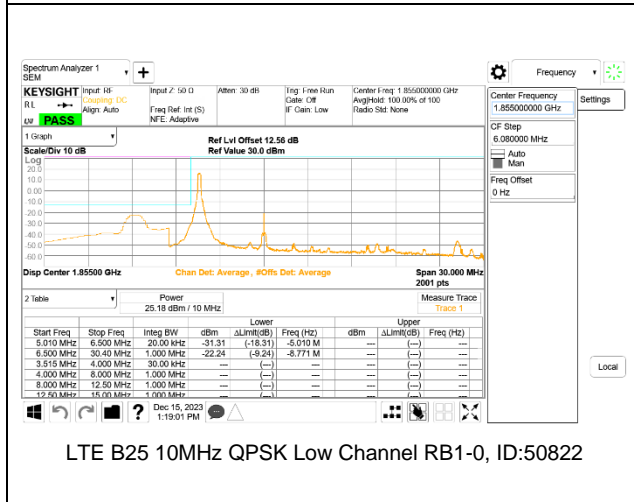

LTE B25 10MHz QPSK Low Channel RB1-0, ID:50822

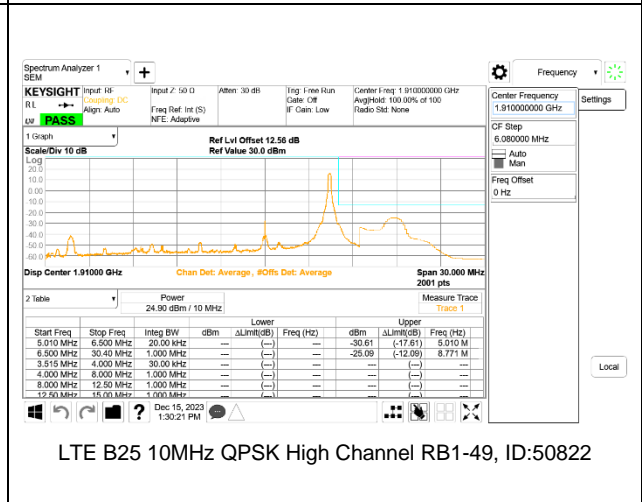

LTE B25 10MHz QPSK High Channel RB1-49, ID:50822

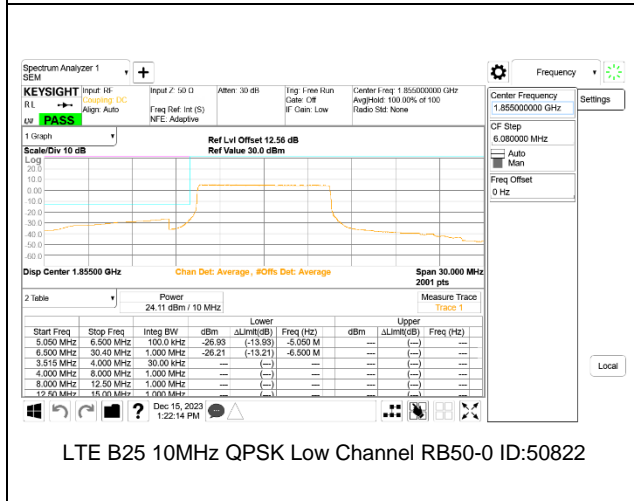

LTE B25 10MHz QPSK Low Channel RB50-0 ID:50822

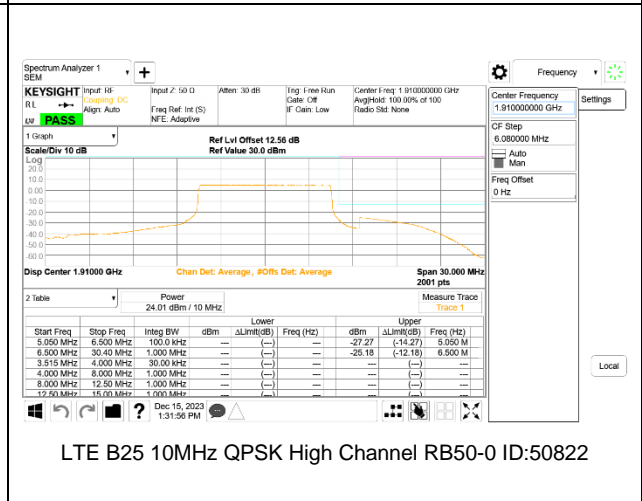

LTE B25 10MHz QPSK High Channel RB50-0 ID:50822

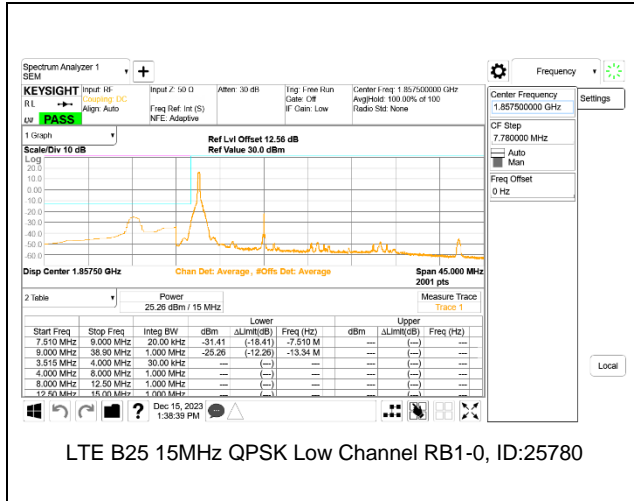

LTE B25 15MHz QPSK Low Channel RB1-0, ID:25780

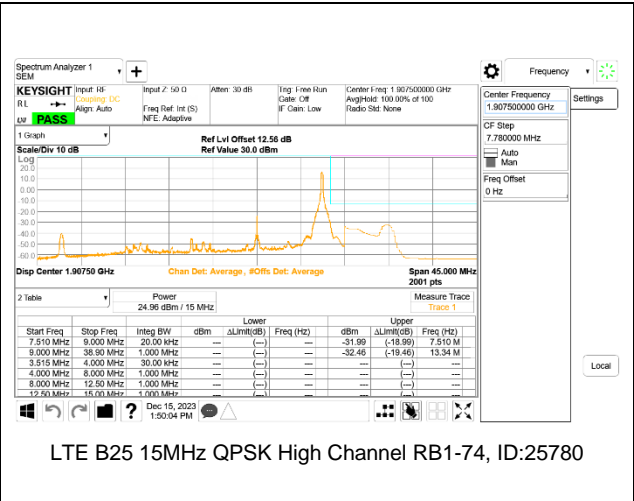

LTE B25 15MHz QPSK High Channel RB1-74, ID:25780

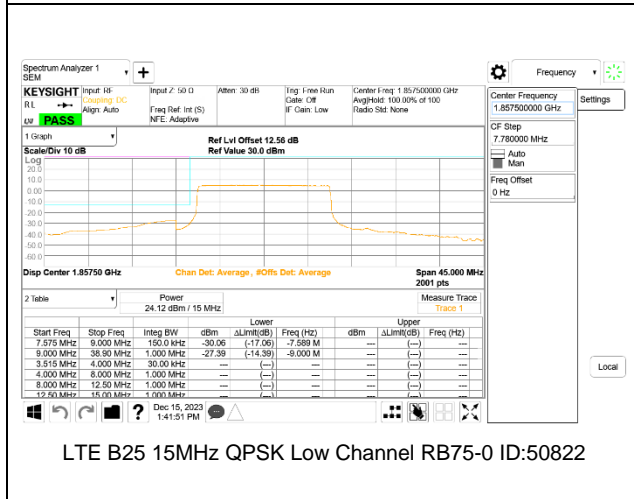

LTE B25 15MHz QPSK Low Channel RB75-0 ID:50822

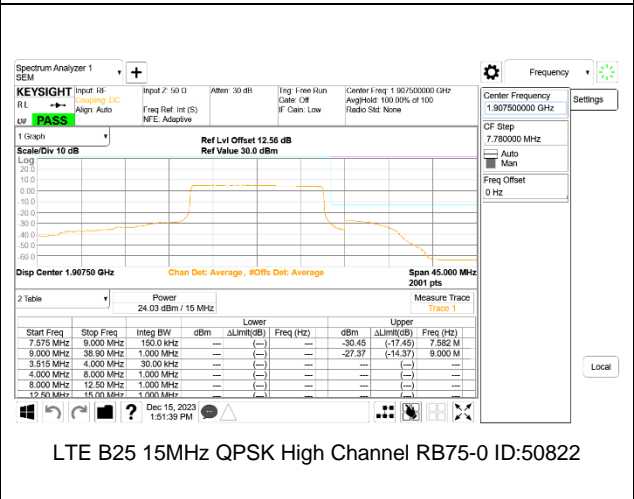

LTE B25 15MHz QPSK High Channel RB75-0 ID:50822

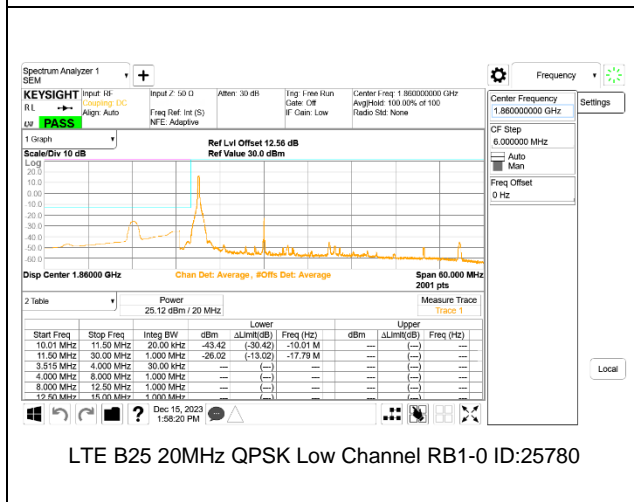

LTE B25 20MHz QPSK Low Channel RB1-0 ID:25780

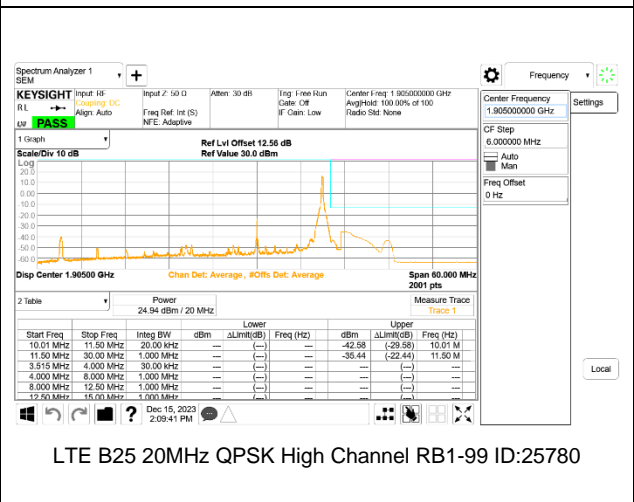

LTE B25 20MHz QPSK High Channel RB1-99 ID:25780

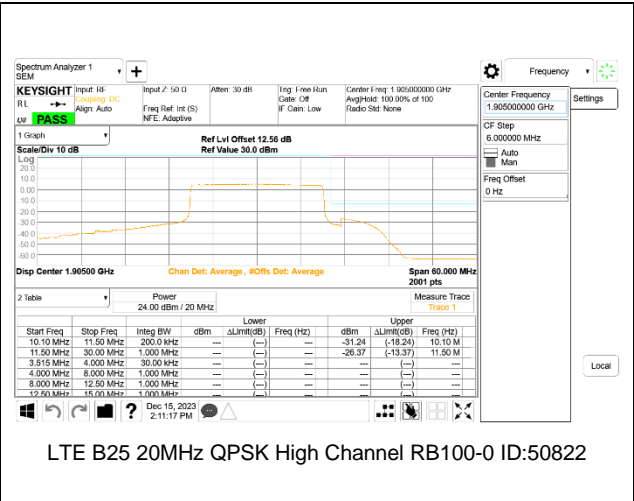
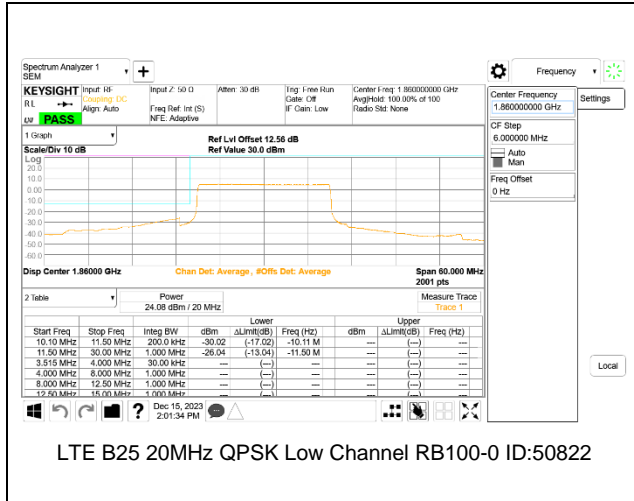

5G NR n25 BANDEDGE

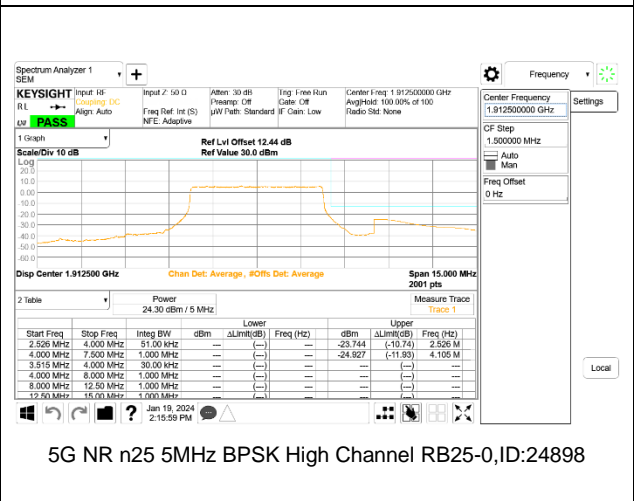
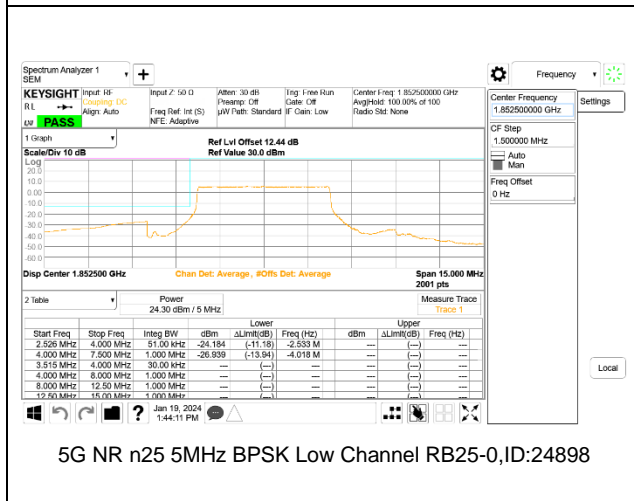
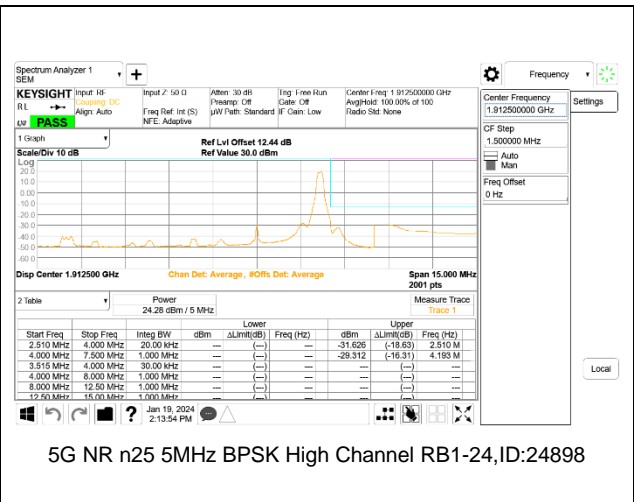
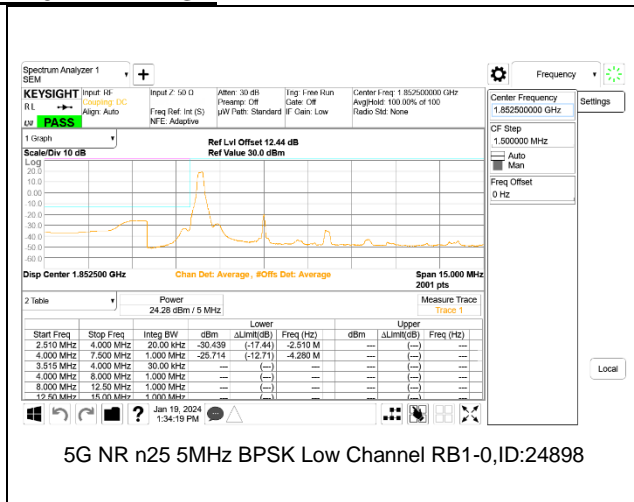

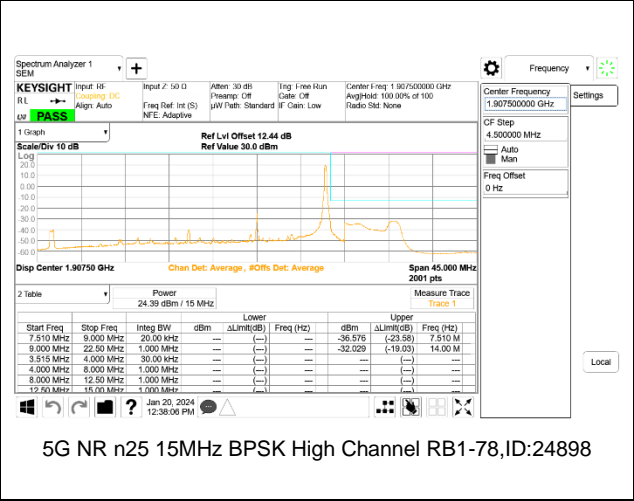
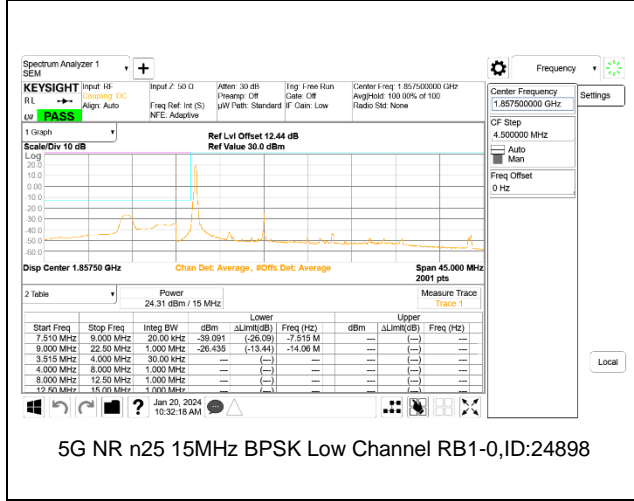
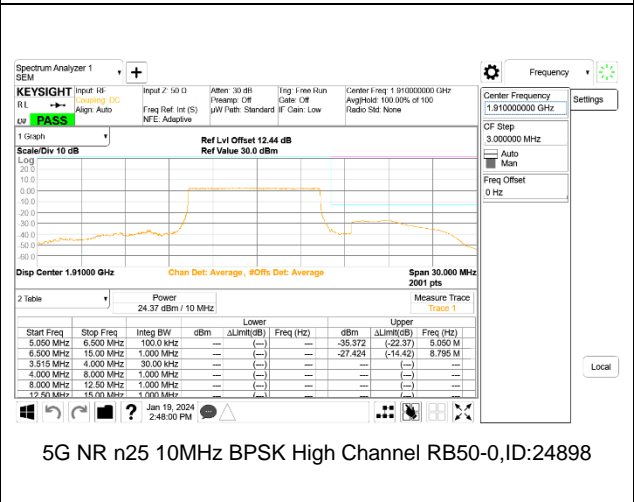
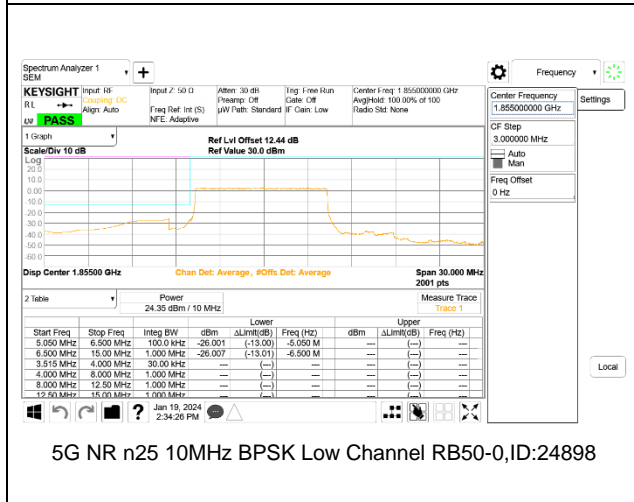
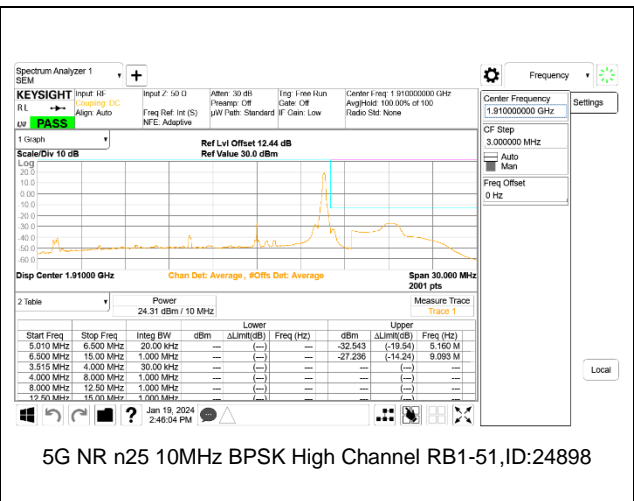
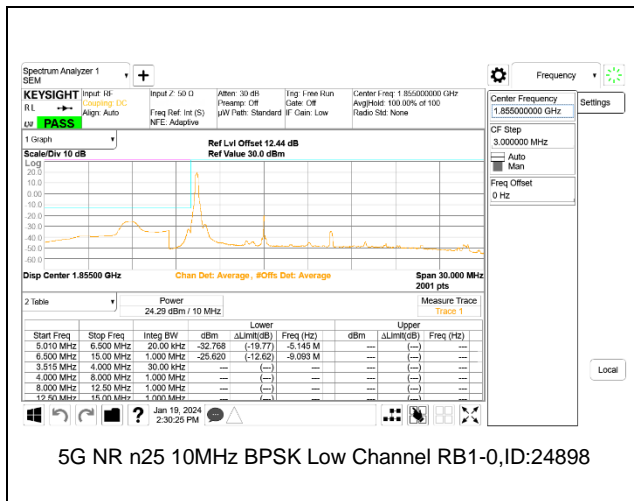

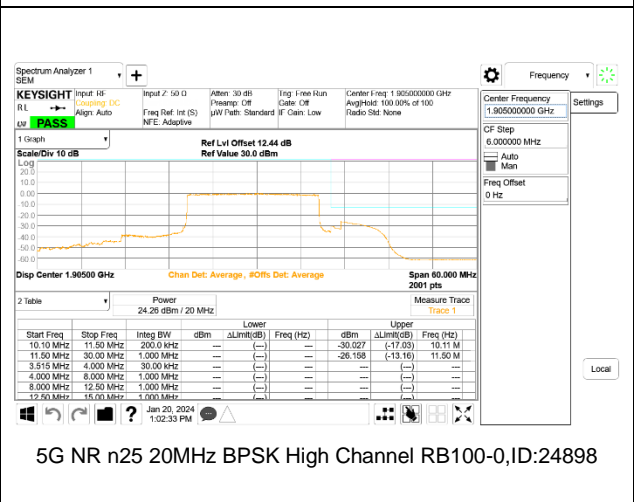
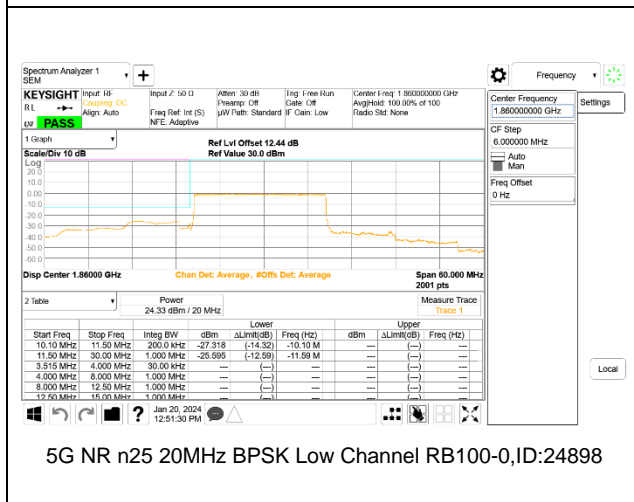
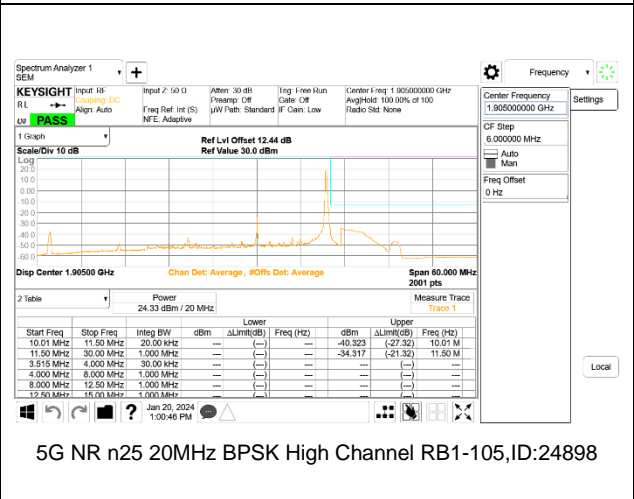
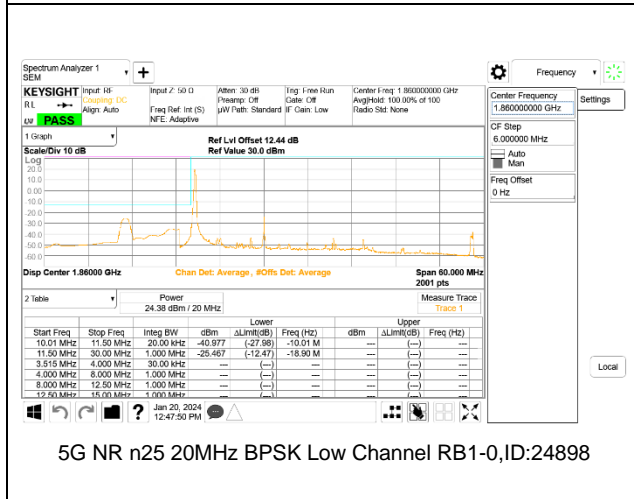
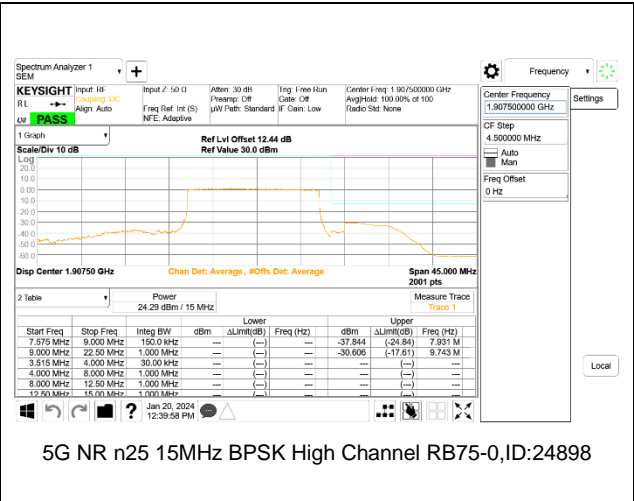
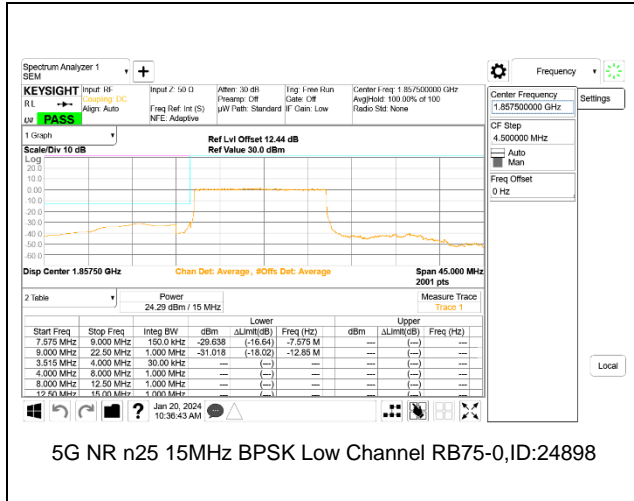

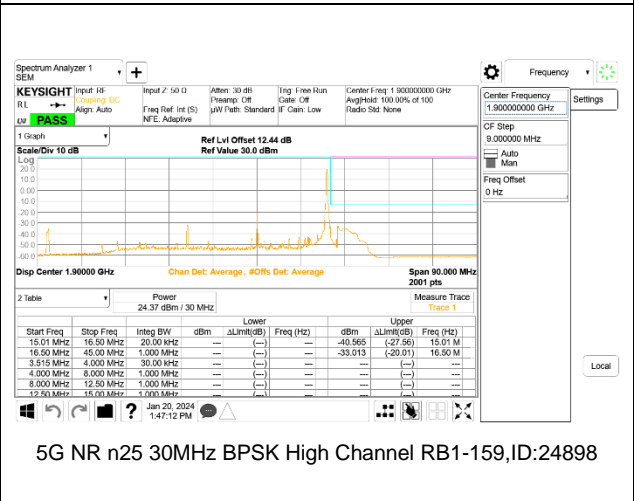
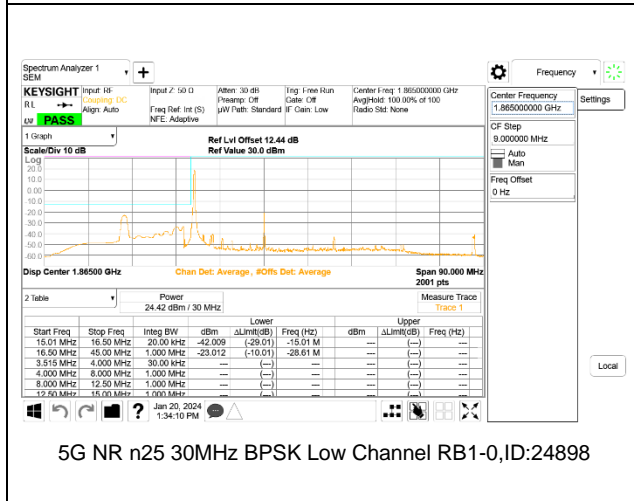
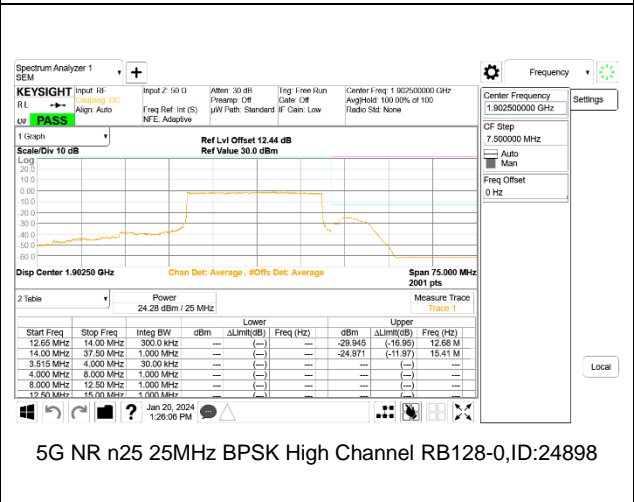
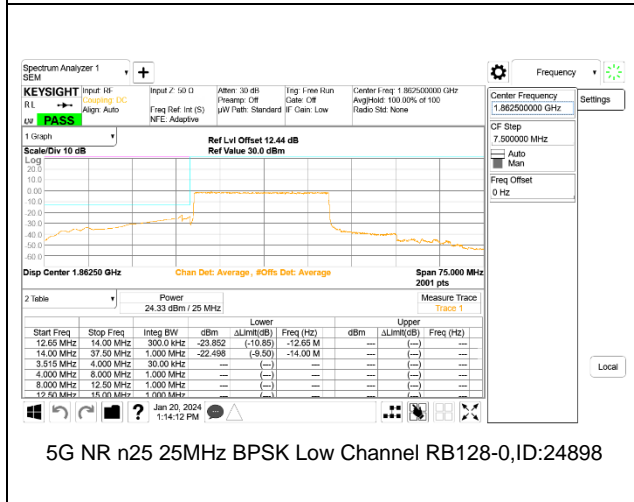
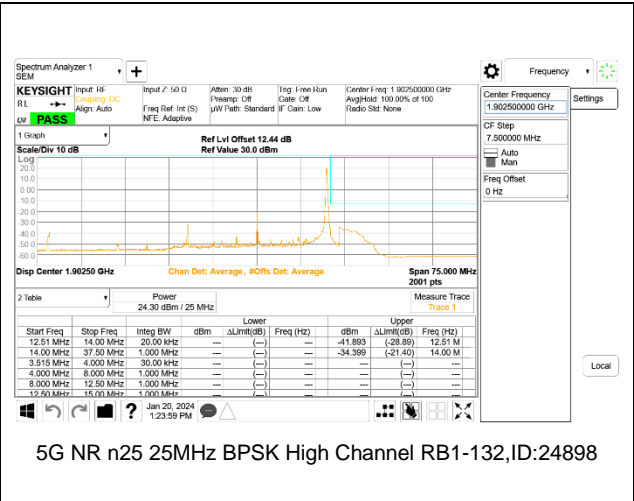
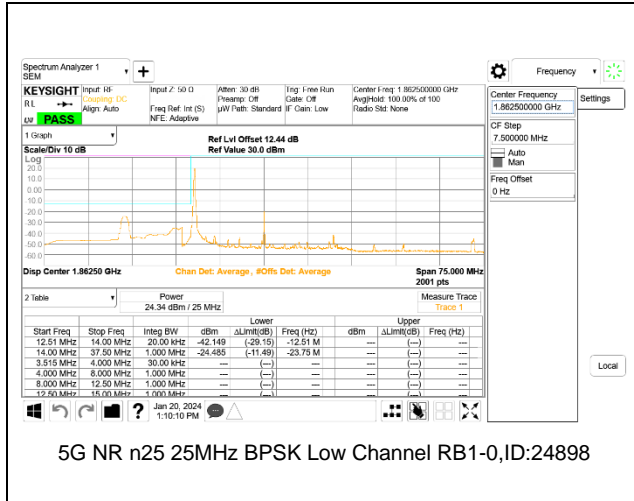

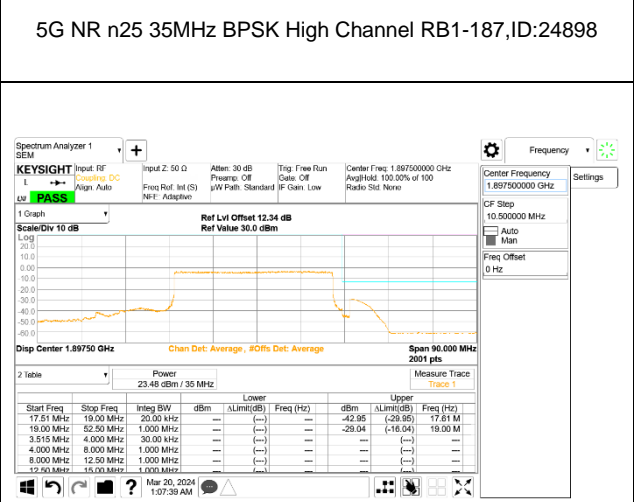
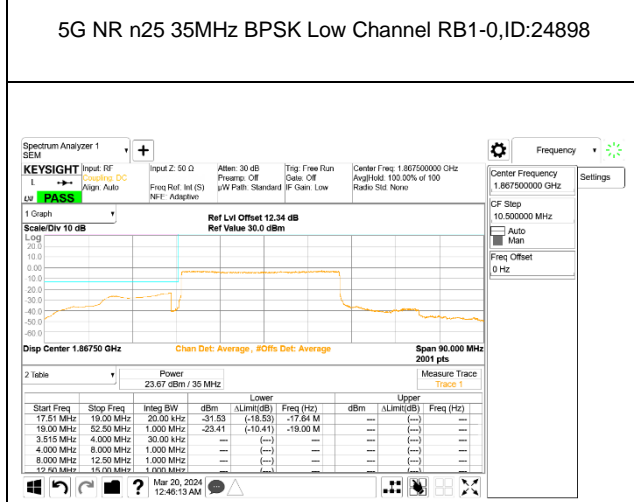
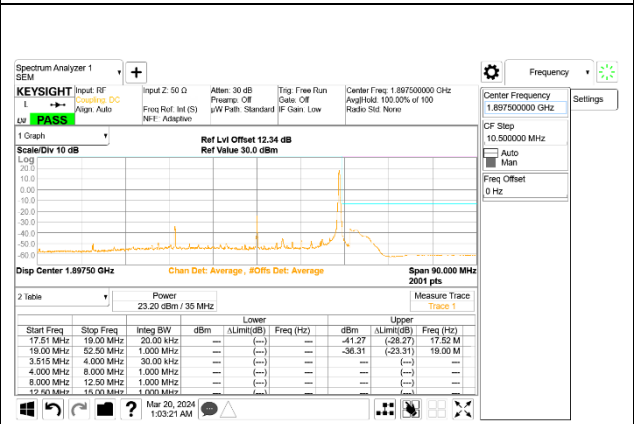
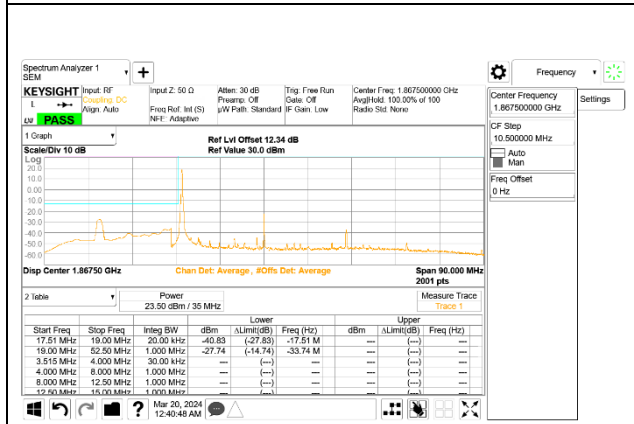
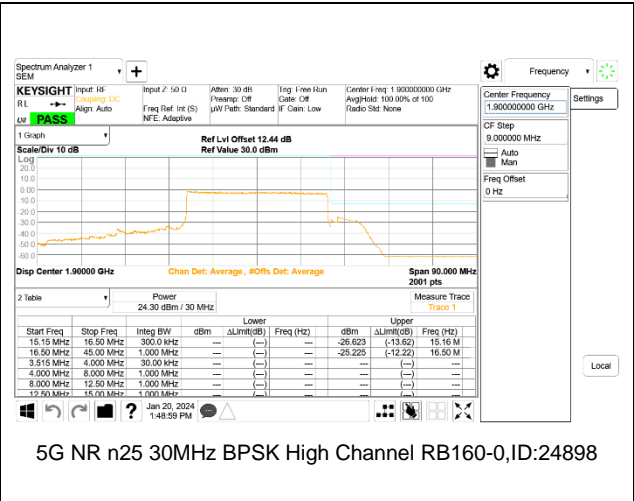
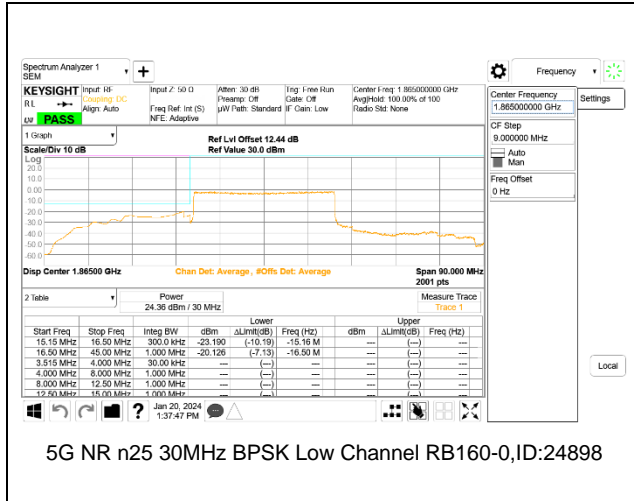

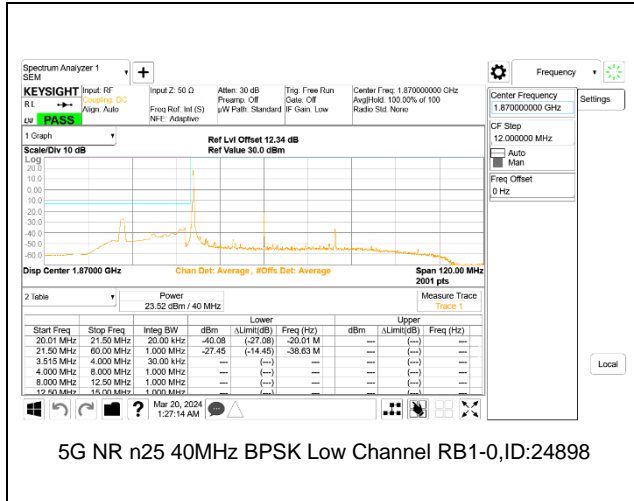

5G NR n25 40MHz BPSK Low Channel RB1-0, ID:24898

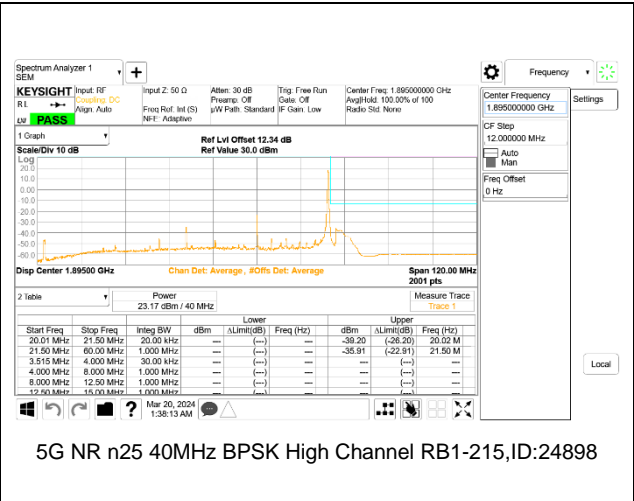

5G NR n25 40MHz BPSK High Channel RB1-215, ID:24898

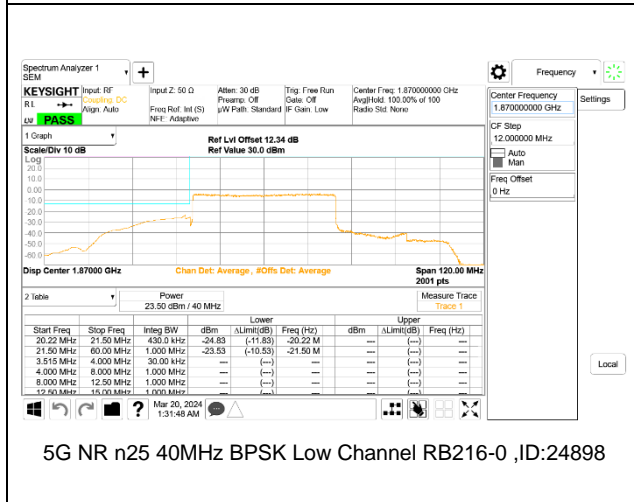

5G NR n25 40MHz BPSK Low Channel RB216-0, ID:24898

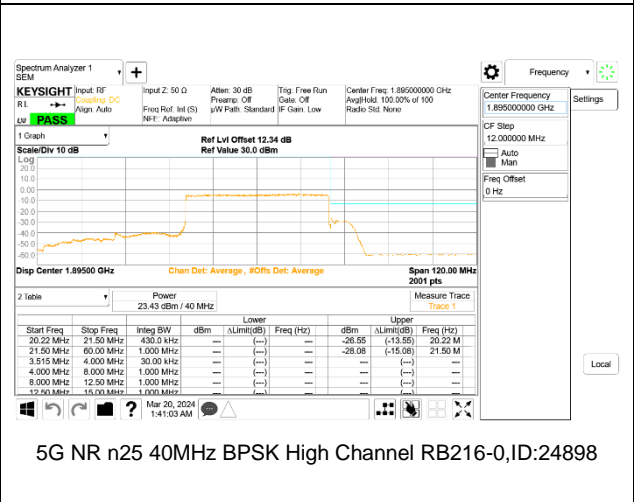

5G NR n25 40MHz BPSK High Channel RB216-0, ID:24898

9.2.8. LTE BAND 26 AND 5G NR n26 (FCC PART 90S)

LIMITS

FCC: §90.691 Emission mask requirements for EA-based systems.

(a) Out-of-band emission requirement shall apply only to the “outer” channels included in an EA license and to spectrum adjacent to interior channels used by incumbent licensees. The emission limits are as follows:

(1) For any frequency removed from the EA licensee's frequency block by up to and including 37.5 kHz, the power of any emission shall be attenuated below the transmitter power (P) in watts by at least $116 \text{ Log}_{10}(f/6.1)$ decibels or $50 + 10 \text{ Log}_{10}(P)$ decibels or 80 decibels, whichever is the lesser attenuation, where f is the frequency removed from the center of the outer channel in the block in kilohertz and where f is greater than 12.5 kHz.

(2) For any frequency removed from the EA licensee's frequency block greater than 37.5 kHz, the power of any emission shall be attenuated below the transmitter power (P) in watts by at least $43 + 10 \text{ Log}_{10}(P)$ decibels or 80 decibels, whichever is the lesser attenuation, where f is the frequency removed from the center of the outer channel in the block in kilohertz and where f is greater than 37.5 kHz.