



# TEST REPORT

**Report Number:** 15107858-E18V2

**Applicant :** Google LLC  
1600 Amphitheatre Parkway  
Mountain View, CA 94043 U.S.A.

**Model :** GZC4K,GQ57S

**FCC ID :** A4RGZC4K

**EUT Description :** PHONE

**Test Standard(s) :** FCC 47 CFR PART 22H, 24E, AND 27L

**Date Of Issue:**

2024-05-17

**Prepared by:**

UL Verification Services Inc.  
47173 Benicia Street  
Fremont, CA 94538, U.S.A.  
TEL: (510) 319-4000  
FAX: (510) 661-0888



Revision History

<u>Rev.</u>	<u>Issue Date</u>	<u>Revisions</u>	<u>Revised By</u>
V1	2024-05-02	Initial Review	--
V2	2024-05-17	Updated Section 2, 5.3, 5.4 ,5.5	Kiya Kedida

## TABLE OF CONTENTS

<b>1. ATTESTATION OF TEST RESULTS</b>	<b>4</b>
<b>2. TEST METHODOLOGY</b>	<b>5</b>
<b>3. FACILITIES AND ACCREDITATION</b>	<b>5</b>
<b>4. DECISION RULES AND MEASUREMENT UNCERTAINTY</b>	<b>6</b>
4.1. METROLOGICAL TRACEABILITY	6
4.2. DECISION RULES	6
4.3. MEASUREMENT UNCERTAINTY	6
4.4. SAMPLE CALCULATION	6
<b>5. INTRODUCTION OF TEST DATA REUSE</b>	<b>7</b>
5.1. DESCRIPTION OF EUT	7
5.2. INTRODUCTION	7
5.3. MODEL DIFFERENCES	7
5.4. SPOT CHECK VERIFICATION RESULTS SUMMARY FOR GZC4K and GQ57S.	8
5.5. REFERENCE DETAIL	9
5.6. SPOT CHECK WORST-CASE CONFIGURATION AND MODE	9
5.7. DESCRIPTION OF TEST SETUP	10
<b>6. TEST AND MEASUREMENT EQUIPMENT</b>	<b>12</b>
<b>Appendix A – Reference Test Report</b>	<b>13</b>

# 1. ATTESTATION OF TEST RESULTS

Applicant Name and Address	Google LLC 1600 Amphitheatre Parkway Mountain View, CA 94043 U.S.A.
Model	GZC4K, GQ57S
FCC ID	A4RGZC4K
EUT Description	Phone
Serial Number	Conducted: 41111FDAS0002H Radiated: 41051FDAS0009P
Sample Receipt Date	2024-03-13
Date Tested	2024-03-11 to 2024-05-01
Applicable Standards	FCC 47 CFR PART 2, PART 22H, PART 24E, AND PART 27L
Test Results	COMPLIES
<p>UL Verification Services Inc. tested the above equipment in accordance with the requirements set forth in the above standards. The test results show that the equipment tested is capable of demonstrating compliance with the requirements as documented in this report.</p> <p>The results documented in this report apply only to the tested sample, under the conditions and modes of operation as described herein. It is the manufacturer's responsibility to assure that additional production units of this model are manufactured with identical electrical and mechanical components. All samples tested were in good operating condition throughout the entire test program. Measurement Uncertainties are published for informational purposes only and were not taken into account unless noted otherwise.</p> <p>This document may not be altered or revised in any way unless done so by UL Verification Services Inc and all revisions are duly noted in the revisions section. Any alteration of this document not carried out by UL Verification Services Inc will constitute fraud and shall nullify the document.</p>	
	
<p>Dan Corona Operations Leader UL Verification Services Inc.</p>	<p>Kiya Kedida Lead Project Engineer UL Verification Services Inc</p>

## 2. TEST METHODOLOGY

The tests documented in this report were performed in accordance with the following:

- ANSI C63.26:2015
- FCC CFR 47 Part 2, Part 22, Part 24, Part 27
- [FCC KDB 971168 D01 v03r01](#): Power Meas License Digital Systems
- [FCC KDB 971168 D02 v02r02](#): Misc Rev Approv License Devices
- [FCC KDB 412172 D01 v01r01](#): Determining ERP and EIRP
- [FCC KDB 484596 D01 v02r03](#): Referencing Test Data

## 3. FACILITIES AND ACCREDITATION

UL Verification Services Inc. is accredited by A2LA, certification #0751.05, for all testing performed within the scope of this report. Testing was performed at the locations noted below.

	Address	ISED CABID	ISED Company Number	FCC Registration
<input type="checkbox"/>	Building 1: 47173 Benicia Street, Fremont, CA 94538 USA	US0104	2324A	550739
<input type="checkbox"/>	Building 2: 47266 Benicia Street, Fremont, CA 94538 USA			
<input type="checkbox"/>	Building 3: 843 Auburn Court, Fremont, CA 94538 USA			
<input checked="" type="checkbox"/>	Building 4: 47658 Kato Rd, Fremont, CA 94538 USA			
<input checked="" type="checkbox"/>	Building 5: 47670 Kato Rd, Fremont, CA 94538 USA			

## 4. DECISION RULES AND MEASUREMENT UNCERTAINTY

### 4.1. METROLOGICAL TRACEABILITY

All test and measuring equipment utilized to perform the tests documented in this report are calibrated on a regular basis, with a maximum time between calibrations of one year or the manufacturers' recommendation, whichever is less, and where applicable is traceable to recognized national standards.

### 4.2. DECISION RULES

The Decision Rule is based on Simple Acceptance in accordance with ISO Guide 98-4:2012 Clause 8.2. (Measurement uncertainty is not taken into account when stating conformity with a specified requirement.)

### 4.3. MEASUREMENT UNCERTAINTY

Where relevant, the following measurement uncertainty levels have been estimated for tests performed on the apparatus:

PARAMETER	U <sub>Lab</sub>
Conducted Antenna Port Emission Measurement	1.940 db
Power Spectral Density	2.466 db
Time Domain Measurements Using SA	3.39 %
RF Power Measurement Direct Method Using Power Meter	0.450 db Peak 1.300 db Ave.
Radio Frequency (Spectrum Analyzer)	141.16 Hz
Occupied Bandwidth	1.22%
Worst Case Conducted Disturbance, 9KHz to 0.15 MHz	3.78 db
Worst Case Conducted Disturbance, 0.15 to 30 MHz	3.40 db
Worst Case Radiated Disturbance, 9KHz to 30 MHz	2.87 db
Worst Case Radiated Disturbance, 30 to 1000 MHz	6.01 db
Worst Case Radiated Disturbance, 1000 to 18000 MHz	4.73 db
Worst Case Radiated Disturbance, 18000 to 26000 MHz	4.51 db
Worst Case Radiated Disturbance, 26000 to 40000 MHz	5.29 db

Uncertainty figures are valid to a confidence level of 95%.

### 4.4. SAMPLE CALCULATION

#### RADIATED EMISSIONS

Where relevant, the following sample calculation is provided:

Field Strength (dBuV/m) = Measured Voltage (dBuV) + Antenna Factor (dB/m) + Cable Loss (dB) – Preamp Gain (dB)

$$36.5 \text{ dBuV} + 18.7 \text{ dB/m} + 0.6 \text{ dB} - 26.9 \text{ dB} = 28.9 \text{ dBuV/m}$$

## 5. INTRODUCTION OF TEST DATA REUSE

### 5.1. DESCRIPTION OF EUT

The EUT is a Phone.

Testing was performed on the parent model and is used to support the application for the parent and variants identified in this report based on the test plan submitted and approved via KDB inquiry by the FCC.

### 5.2. INTRODUCTION

This application for certification is leveraging the data reuse procedures from KDB 484596 D01 based on reference FCC ID: A4RGGX8B to cover variant model FCC ID: A4RGZC4K. The major difference between the parent/reference model and the variant model is depopulation of LTE and 5G NR Bands. All other circuitry and features are identical. The data reuse test plan was approved via manufacturer KDB inquiry.

### 5.3. MODEL DIFFERENCES

The manufacturer hereby declares the following for models GZC4K and GQ57S.

GGX8B, GZC4K and GQ57S are highly similar, with the only differences being listed on the table below.

They have the same PCB layout, design, common components, antennas, antenna locations and housing cases.

Spot check verification has been done on models GZC4K in accordance with the test plan approved via KDB inquiry. Comparison of the models, upper deviation is within 0.5dB range of antenna port data and all tests are under FCC Technical Limits. The results documented for model GGX8B may be applied as representative to models GZC4K and GQ57S.

Model	FCC ID	Model Changes
GGX8B	A4RGGX8B	Reference model
GZC4K, GQ57S	A4RGZC4K	Variant model, Disabled LTE B29, 5G NR n29, n48, n70, n79 from the reference model via software. The Variant device A4RGZC4K supports NR band n79 for non-US carriers, and the reference device A4RGGX8B does not. NR n79 will not be part of FCC certification. FR2 mmWave depopulated.  The GZC4K and GQ57S are identical in Hardware / Software to each other. The only difference lies in the model names, which serve marketing purposes. All test samples used are Model GZC4K..

### 5.4.SPOT CHECK VERIFICATION RESULTS SUMMARY

Technology	Worst Mode	Test Item	Frequency MHz	FCC ID:A4RGGX8B (dBm)	FCC ID:A4RGZC4K (dBm)	Delta (dB)
GSM 850	GPRS 1 Slot	Cond Power	848.8	32.60	32.50	-0.1
	GPRS 1 Slot	RSE	848.8	-56.94	-55.69	1.25
GSM 1900	GPRS 1 Slot	Cond Power	1909.8	29.90	29.92	0.02
	GPRS 1 Slot	RSE	1909.8	-53.53	-51.77	1.76
WCDMA B5	REL 99	Cond Power	836.6	24.90	24.95	0.05
	REL 99	RSE	836.6	-56.78	-57.12	-0.34
WCDMA B2	REL 99	Cond Power	1852.4	24.80	24.75	-0.05
	REL 99	RSE	1852.4	-54.53	-53.07	1.46
WCDMA B4	REL 99	Cond Power	1752.6	24.80	25.11	0.31
	REL 99	RSE	1752.6	-54.94	-52.80	2.14



### 5.5. REFERENCE DETAIL

Reference application that contains the reused reference data.

Reference FCC ID	Reference Application	Variant model FCC ID	Report Title/Section
A4RGGX8B	15107858-E1	A4RGZC4K	FCC Report WWAN [2G3G] / All Sections

### 5.6. SPOT CHECK WORST-CASE CONFIGURATION AND MODE

The spot checks were performed on the worst-case configurations based on the parent model of reference report.

## 5.7. DESCRIPTION OF TEST SETUP

SUPPORT TEST EQUIPMENT						
Description	Manufacturer	Model	Serial Number	FCC ID/ DoC		
Laptop	Dell	Latitude 7300	876819127	DoC		
AC/DC adapter	Dell	DA130PE1-00	CN-0M55GJ-DES00-066-5THK-A02	DoC		
Power Adapter	Google	GW8L7	1HV003B901000B9DE	DoC		
I/O CABLES (RF CONDUCTED TEST)						
Cable No.	Port	# of Identical Ports	Connector Type	Cable Type	Cable Length (m)	Remarks
1	AC	3	US 115V	Un-shielded	2.0	N/A
2	USB	1	USB-C	Un-shielded	1.0	N/A
3	RF In/Out	1	EUT	Un-shielded	0.6	N/A
4	RF In/Out	1	Communication Test Set	Un-shielded	1.2	N/A
5	RF In/Out	1	Barrel	N/A	N/A	N/A
I/O CABLES (RF RADIATED TEST)						
Cable No.	Port	# of Identical Ports	Connector Type	Cable Type	Cable Length (m)	Remarks
1	AC	1	US 115V	Un-shielded	2.0	N/A
1	USB	1	USB-C	Un-shielded	1	N/A
2	RF In/Out	1	Antenna	Un-shielded	5.0	N/A

**CONDUCTED SETUP**

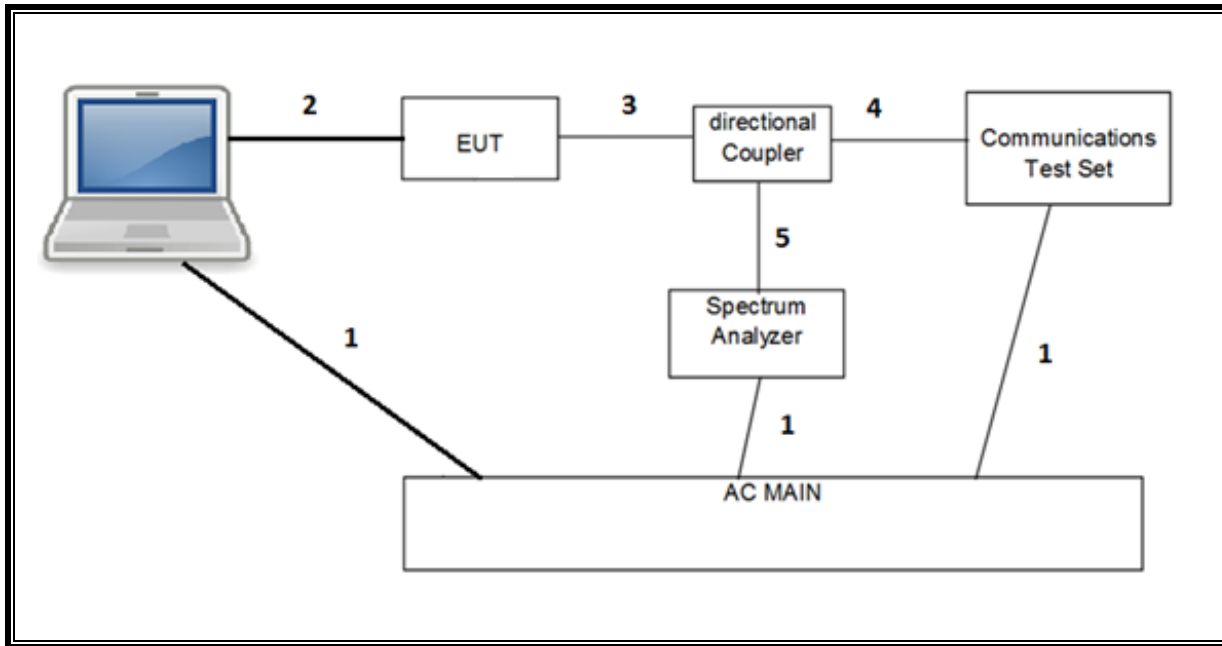

**RADIATED SETUP**

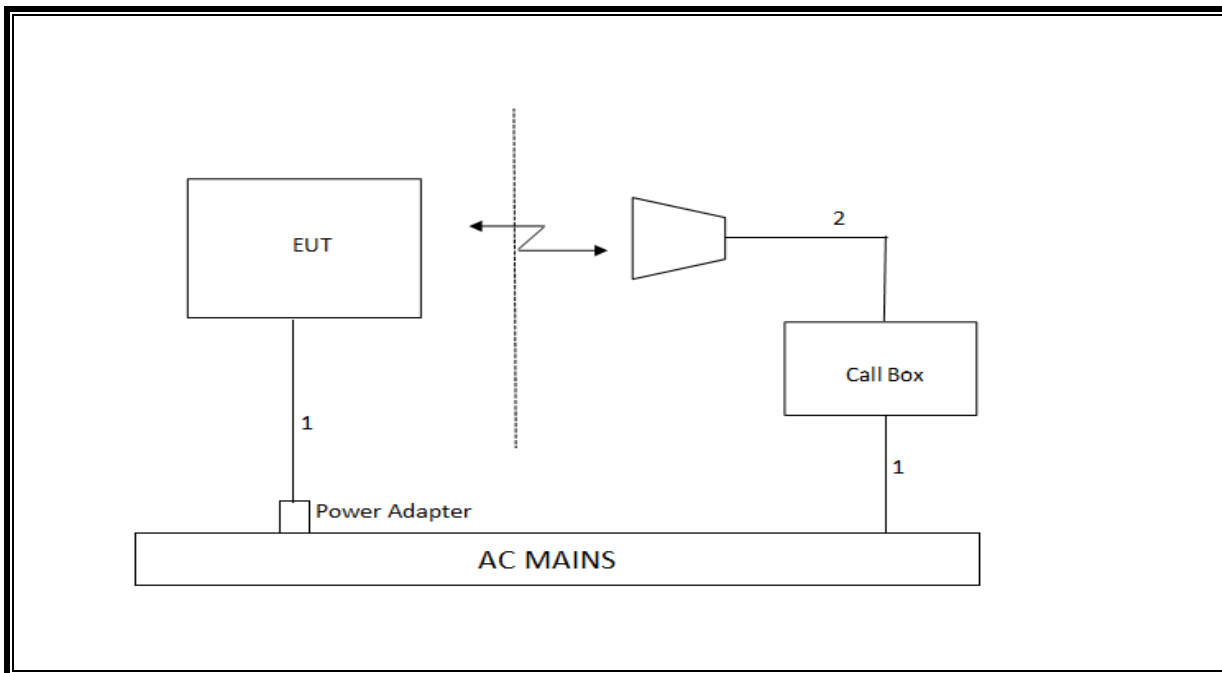

## 6. TEST AND MEASUREMENT EQUIPMENT

The following test and measurement equipment was utilized for the tests documented in this report:

TEST EQUIPMENT LIST				
Description	Manufacturer	Model	Asset	Cal Due
Antenna, Horn 1-18GHz	ETS-Lindgren	3117	80430	2024-08-31
Antenna, Horn 1-18GHz	ETS Lindgren	3117	84796	2024-09-30
Antenna, Broadband Hybrid, 30MHz to 3000MHz	SUNAR	JB3	222009	2024-10-31
RF Filter Box, 1-18GHz	UL-FR1	NA	217255	2024-10-31
RF Filter Box, 1-18GHz (Chamber T)	UL-FR1	RATS 2	226781	2024-09-30
Amplifier, 10KHz to 1GHz, 32dB	Sonoma	310N	430250	2024-09-30
EMI TEST RECEIVER	Rohde & Schwarz	ESW44	169936	2025-02-28
EMI TEST RECEIVER	Rohde & Schwarz	ESW44	169935	2025-02-28
Wideband Communication Test Set, Call Box	R&S GmbH & Co. KG	CMW500	85943	2025-02-28
Directional Coupler	KRYTAR	152610	198816	2024-10-31
Power Meter, P-series single channel	Keysight	N1912A	90719	2025-01-31
Power Sensor, P - series, 50MHz to 18GHz, Wideband	Keysight	N1921A	81319	2025-01-31
Filter, HPF 1.2GHz	Wainwright Instruments GmbH	WHKX6-948-1.2/15G-40ST	99	2024-10-31
Spectrum Analyzer, PXA, 2Hz to 44GHz	Keysight	N9030B	231739	2025-01-31
Spectrum Analyzer, PXA, 2Hz to 44GHz	Keysight	N9030B	245120	2025-02-28
Wideband Communication Test Set, Call Box	R&S GmbH & Co. KG	CMW500	222793	2025-02-28
Wideband Communication Test Set, Call Box	R&S GmbH & Co. KG	CMW500	222797	2025-02-28
Chamber, Environmental	Thermotron Corp.	SM-16C Mini-Max	179936	2024-06-30
Transmitting Antenna, Horn Antenna	TEKBOX Digital Solutions	TBMA4	226709	C.N.R.
Antenna, Horn 18 to 26.5GHz	A.R.A.	MWH-1826/B	199659	2024-12-31
Amplifier 18-26.5GHz, +5Vdc, -54dBm P1dB	AMPLICAL	AMP18G26.5-60	234683	2024-03-29
DC Power Supply	GWINSTEK	GPS18500	N/A	C.N.R.
UL AUTOMATION SOFTWARE				
CLT Software	UL	UL RF	V2023.11.21.0	
Power Measurement Software	UL	UL RF	V2023.08.14.0	
Radiated test software	UL	UL RF	Ver 9.5 2023-05-01	

**NOTES:**

- \* Testing is completed before equipment expiration date.

---

## Appendix A – Reference Test Report

Attached is the test report (15107858-E1) containing the reference data from the parent model as detailed in section 5.5.