

**5G NR n30 EMISSION MASK**

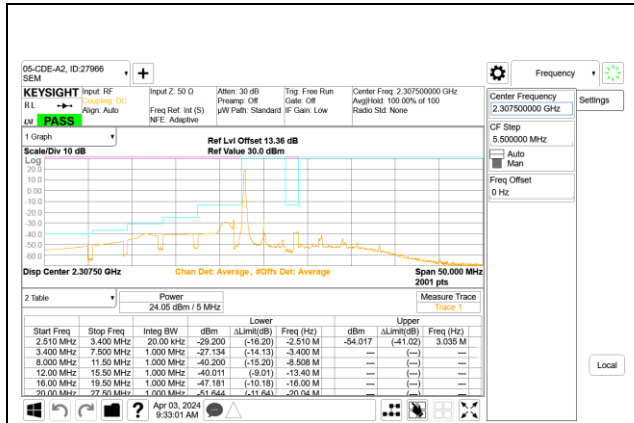

5G NR n30 5MHz BPSK Low Channel RB1-0 (Low side), ID:27966

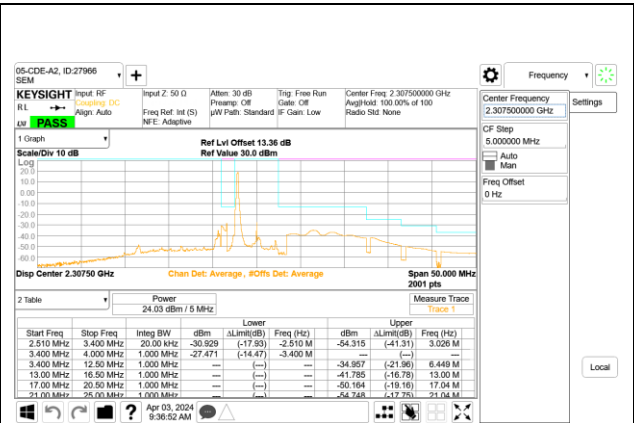

5G NR n30 5MHz BPSK Low Channel RB1-0 (High side), ID:27966

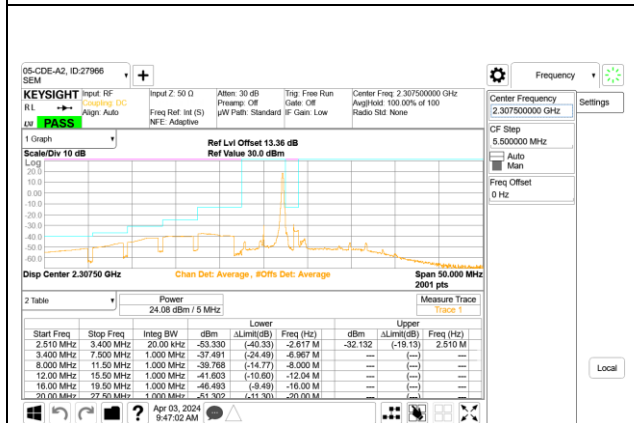

5G NR n30 5MHz BPSK Low Channel RB1-24 (Low side), ID:27966

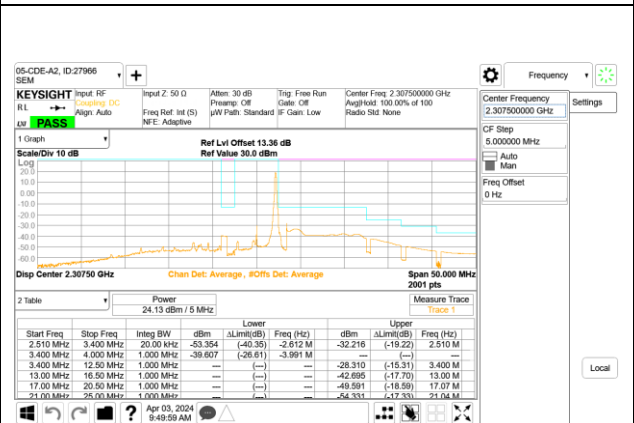

5G NR n30 5MHz BPSK Low Channel RB1-24 (High side), ID:27966

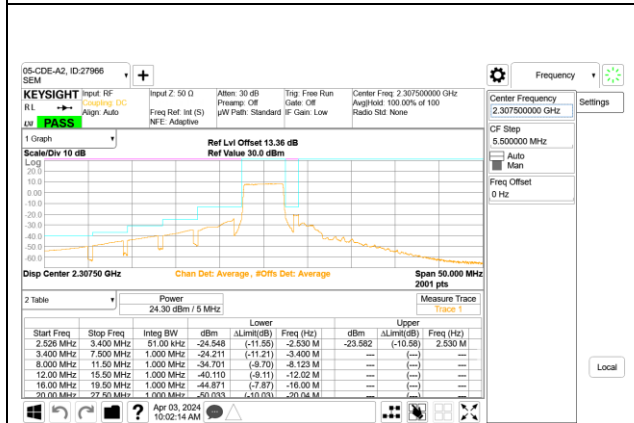

5G NR n30 5MHz BPSK Low Channel RB25-0 (Low side), ID:27966

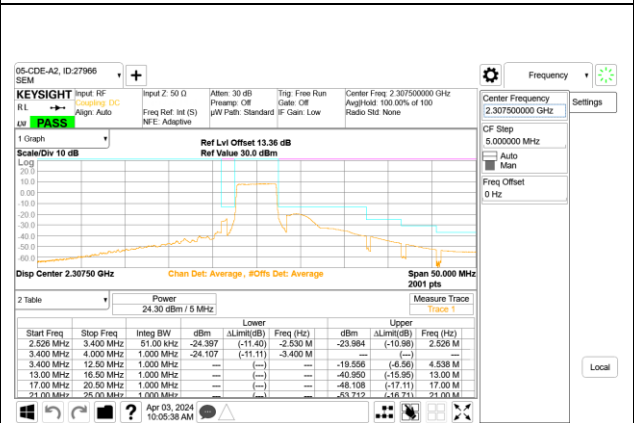

5G NR n30 5MHz BPSK Low Channel RB25-0 (High side), ID:27966

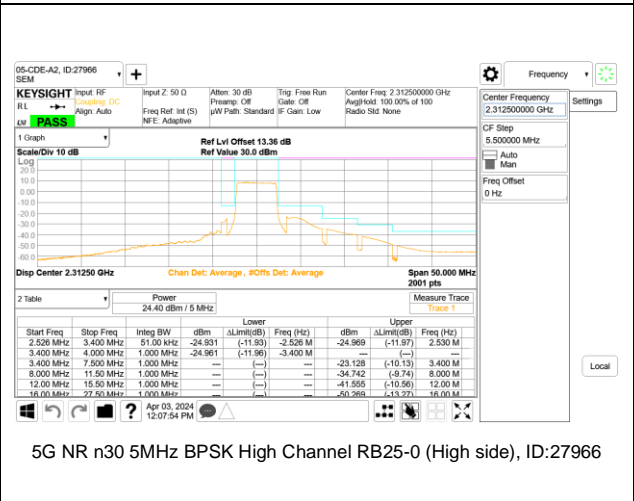
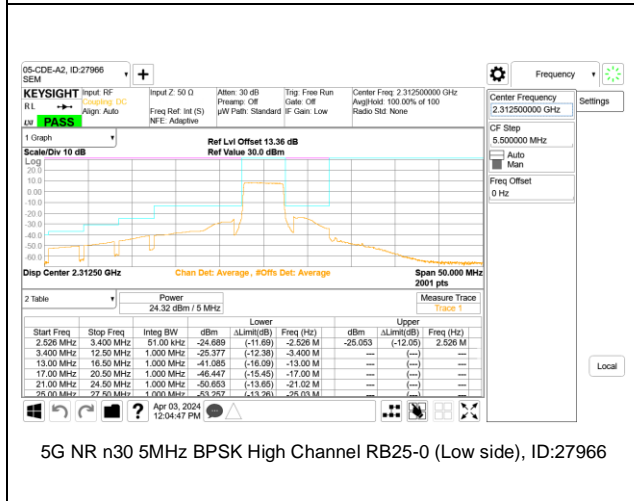
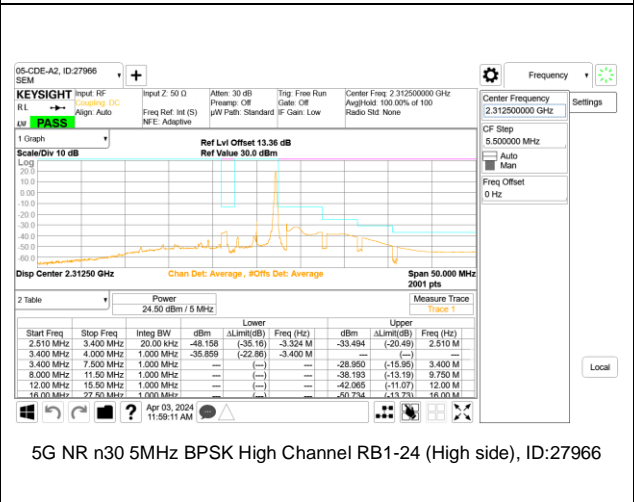
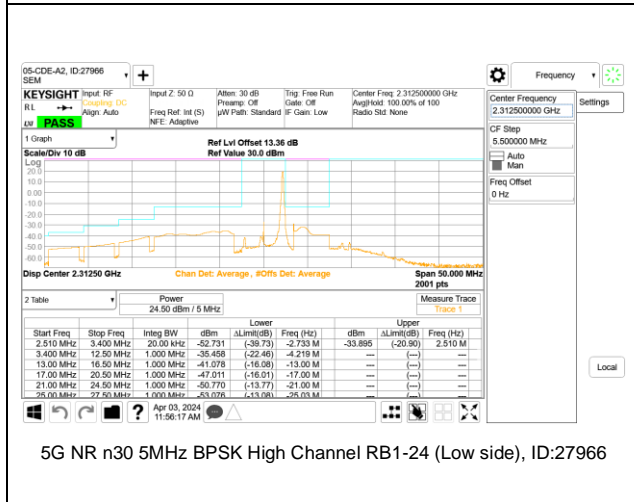
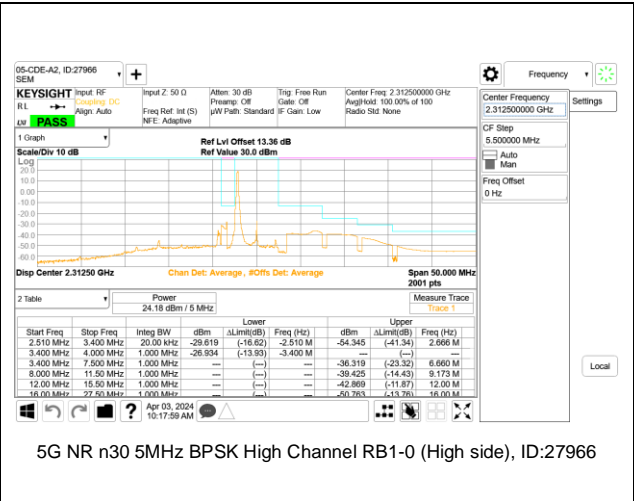
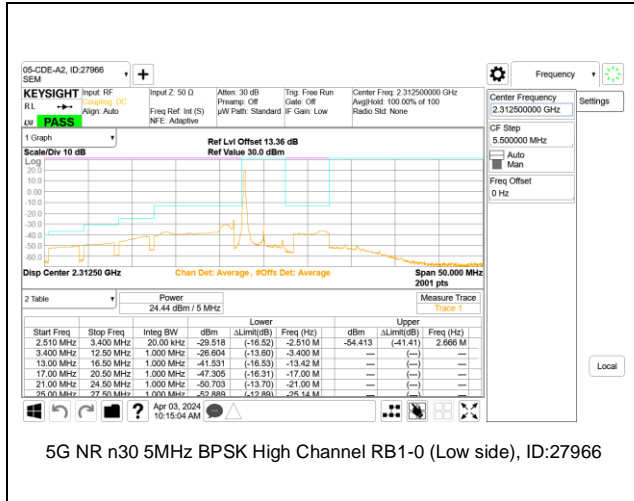

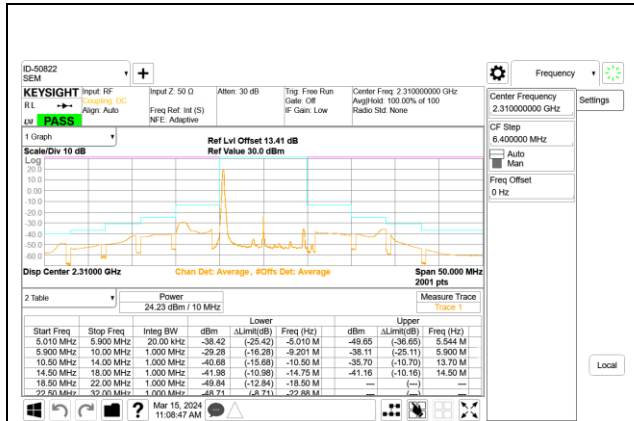

5G NR n30 10MHz BPSK Middle Channel RB1-0, ID:50822

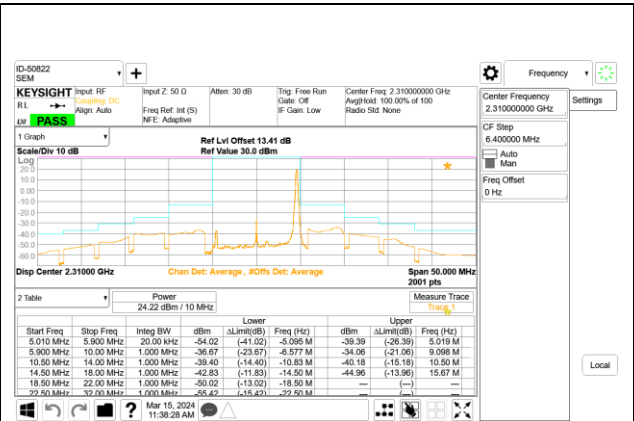

5G NR n30 10MHz BPSK Middle Channel RB1-51, ID:50822

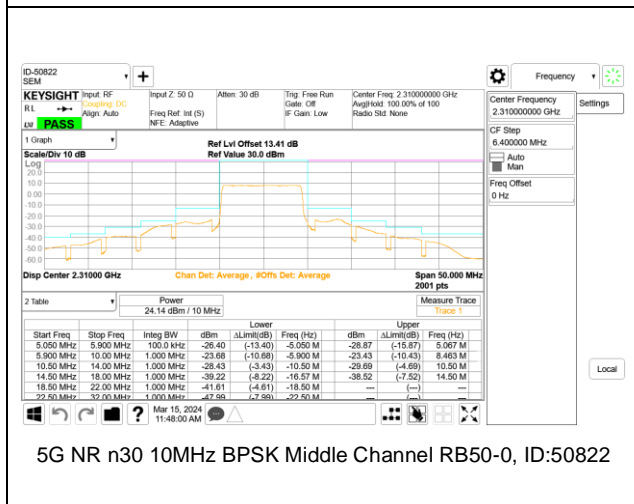

5G NR n30 10MHz BPSK Middle Channel RB50-0, ID:50822

Intentionally Blank

## 9.2.11. LTE BAND 41 AND 5G NR n41HPUE

### LIMITS

FCC: §27.53

(m)(4) For mobile digital stations, the attenuation factor shall be not less than  $40 + 10 \log (P)$  dB on all frequencies between the channel edge and 5 megahertz from the channel edge,  $43 + 10 \log (P)$  dB on all frequencies between 5 megahertz and X megahertz from the channel edge, and  $55 + 10 \log (P)$  dB on all frequencies more than X megahertz from the channel edge, where X is the greater of 6 megahertz or the actual emission bandwidth as defined in paragraph (m)(6) of this section. In addition, the attenuation factor shall not be less than  $43 + 10 \log (P)$  dB on all frequencies between 2490.5 MHz and 2496 MHz and  $55 + 10 \log (P)$  dB at or below 2490.5 MHz. Mobile Satellite Service licensees operating on frequencies below 2495 MHz may also submit a documented interference complaint against BRS licensees operating on channel BRS Channel 1 on the same terms and conditions as adjacent channel BRS or EBS licensees.

**LTE BAND 41 ADJACENT CHANNEL POWER**

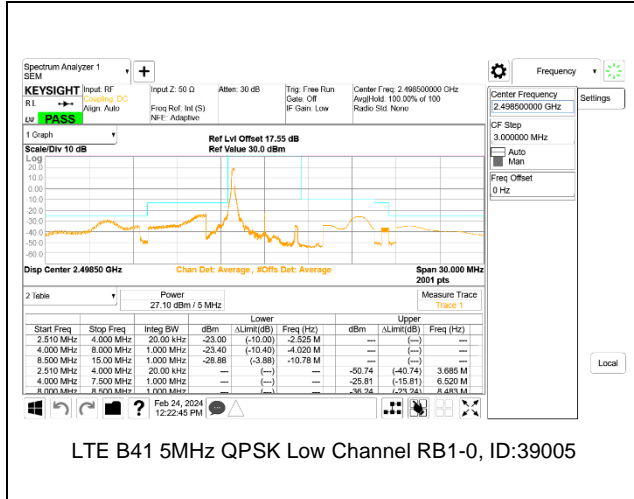

LTE B41 5MHz QPSK Low Channel RB1-0, ID:39005

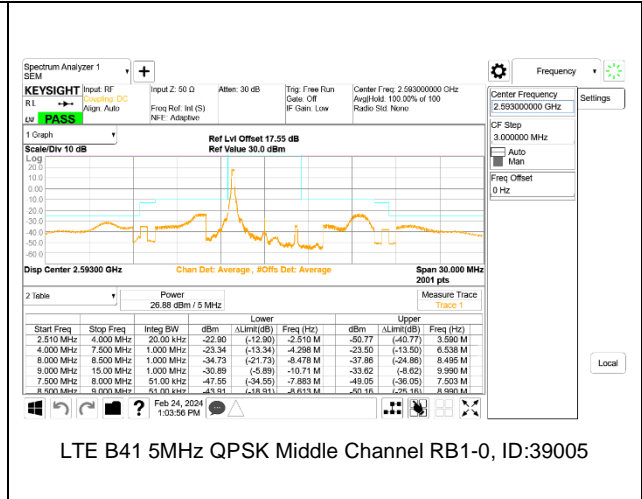

LTE B41 5MHz QPSK Middle Channel RB1-0, ID:39005

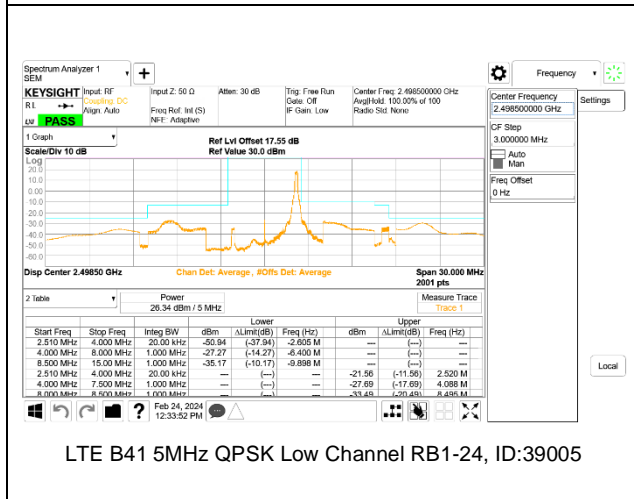

LTE B41 5MHz QPSK Low Channel RB1-24, ID:39005

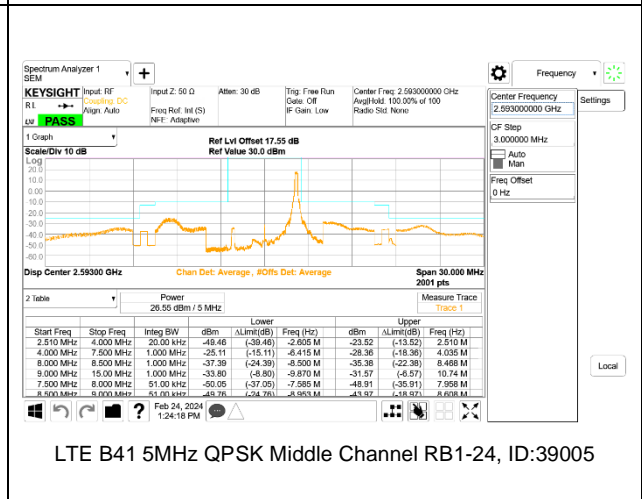

LTE B41 5MHz QPSK Middle Channel RB1-24, ID:39005

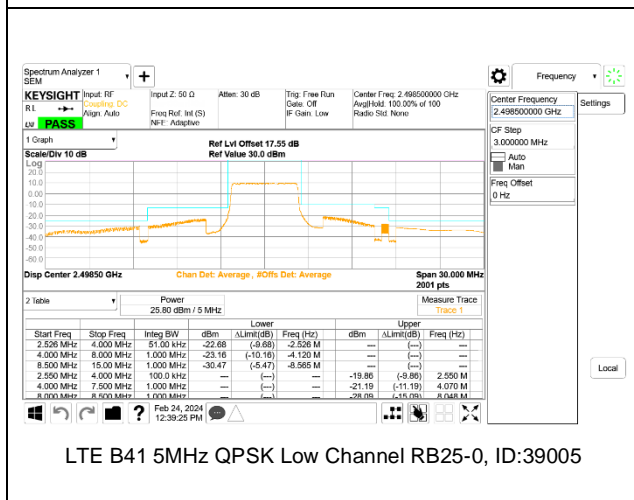

LTE B41 5MHz QPSK Low Channel RB25-0, ID:39005

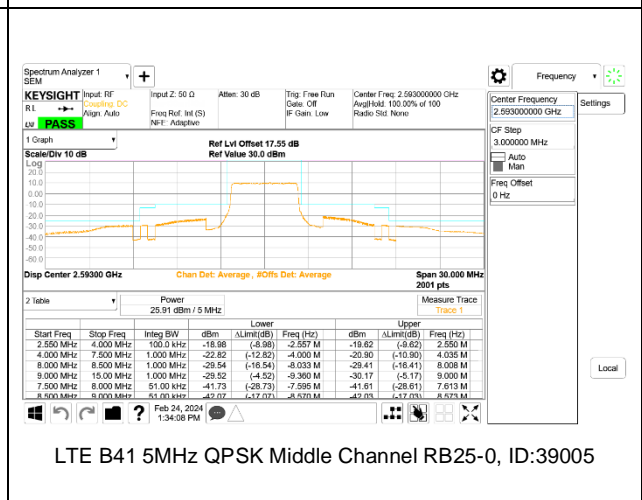

LTE B41 5MHz QPSK Middle Channel RB25-0, ID:39005

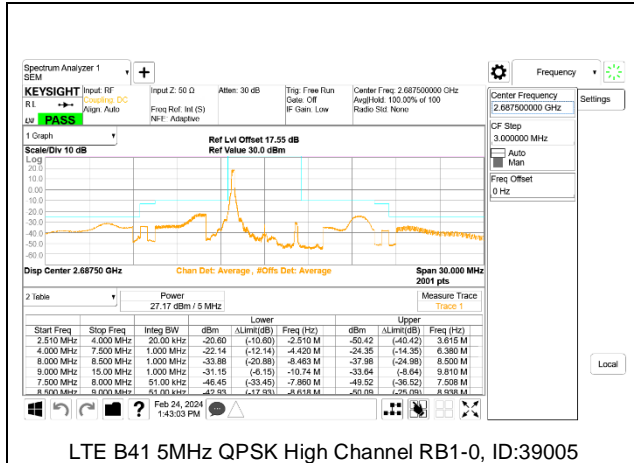

LTE B41 5MHz QPSK High Channel RB1-0, ID:39005

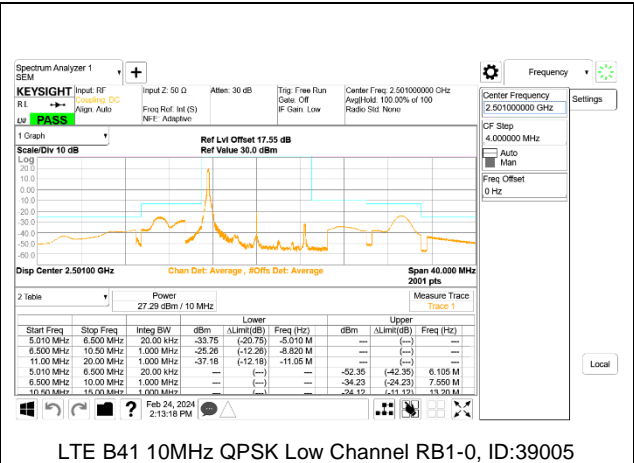

LTE B41 10MHz QPSK Low Channel RB1-0, ID:39005

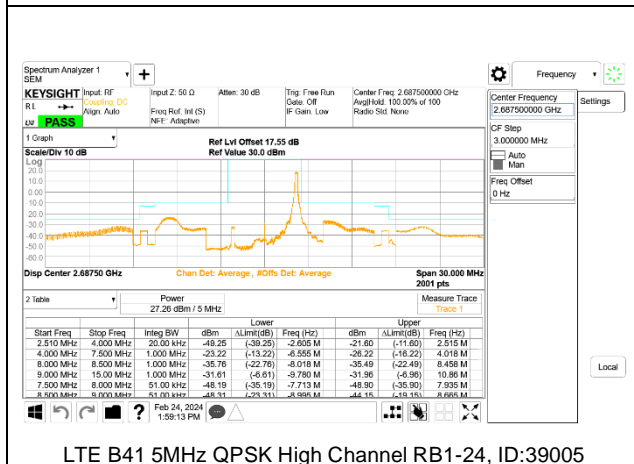

LTE B41 5MHz QPSK High Channel RB1-24, ID:39005

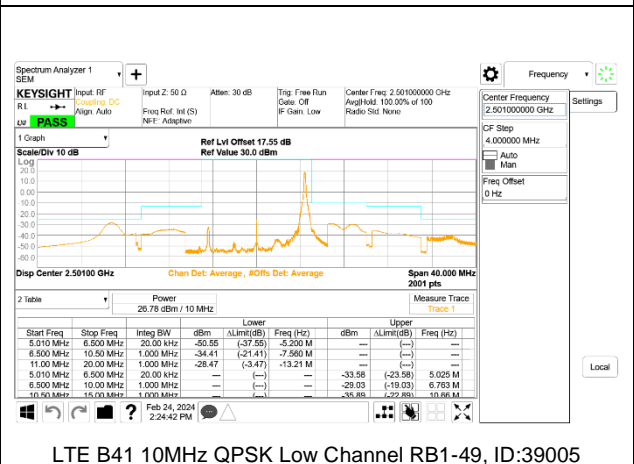

LTE B41 10MHz QPSK Low Channel RB1-49, ID:39005

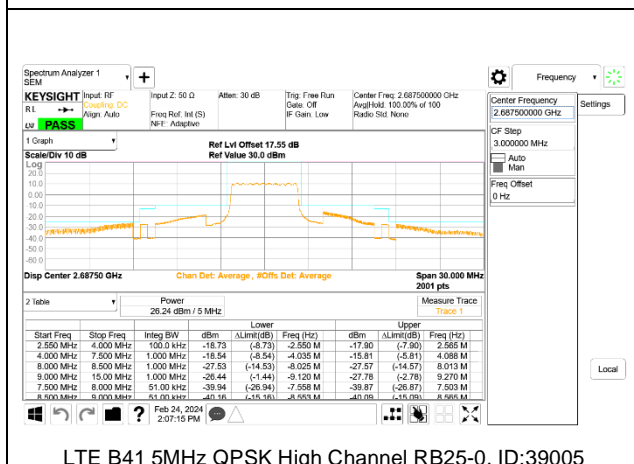

LTE B41 5MHz QPSK High Channel RB25-0, ID:39005

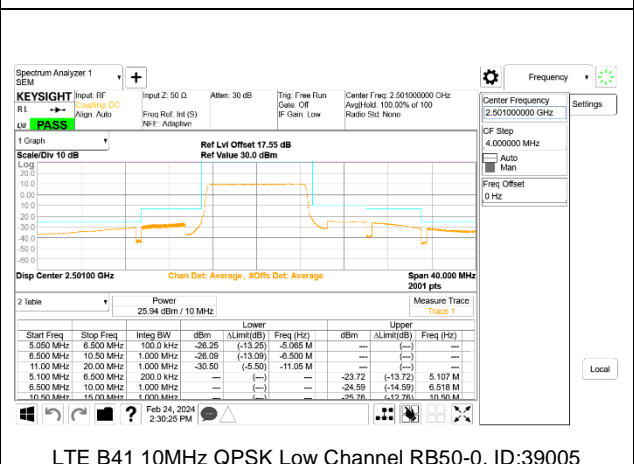

LTE B41 10MHz QPSK Low Channel RB50-0, ID:39005

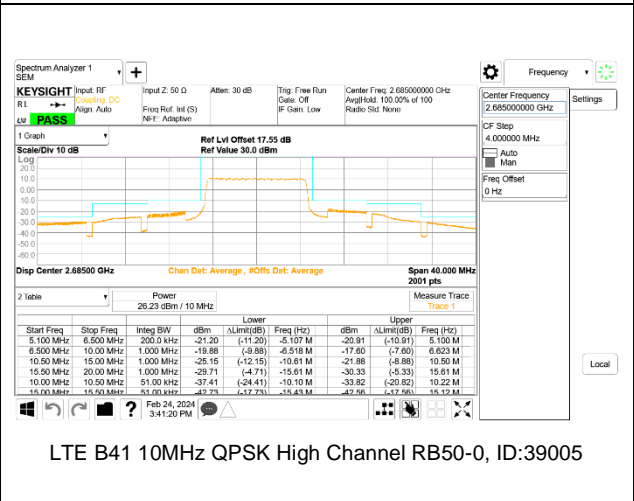
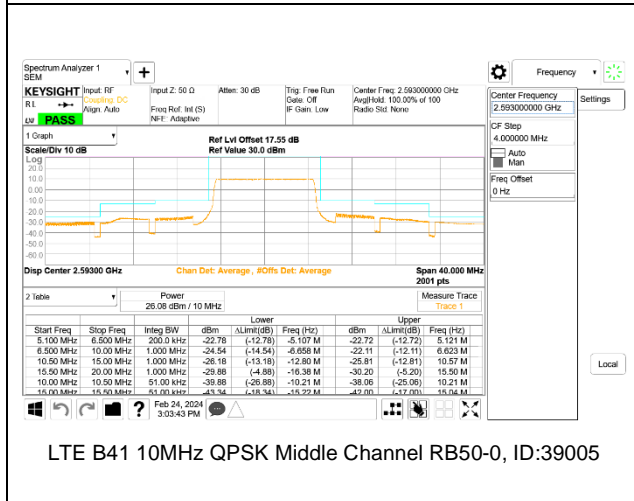
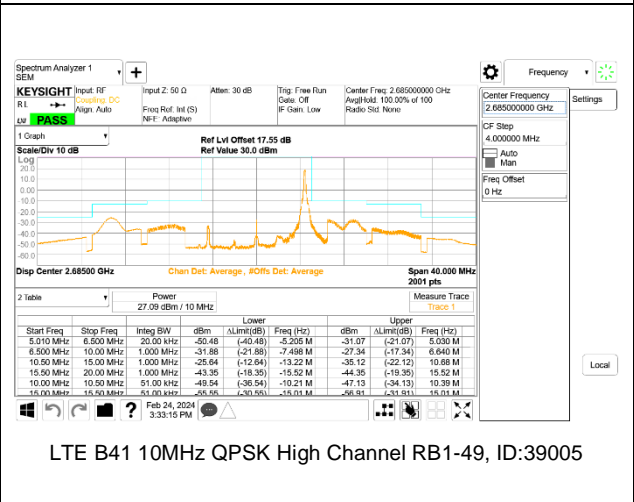
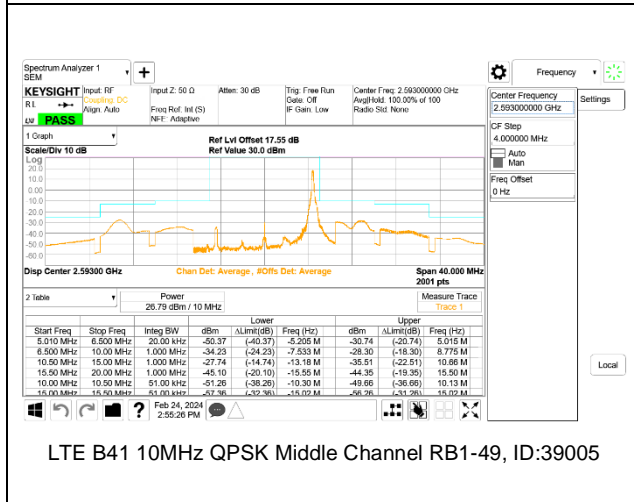
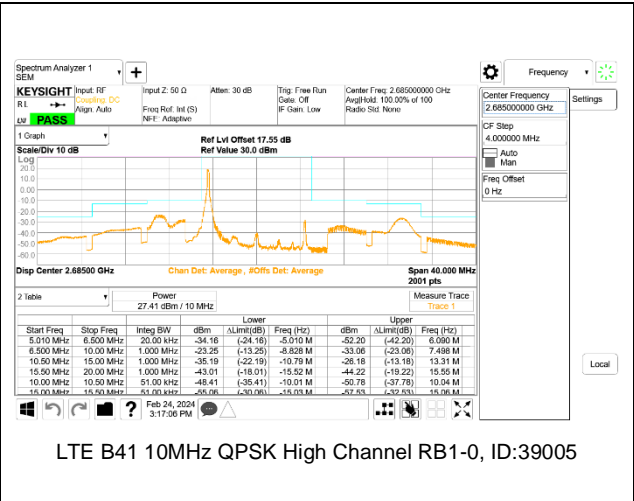
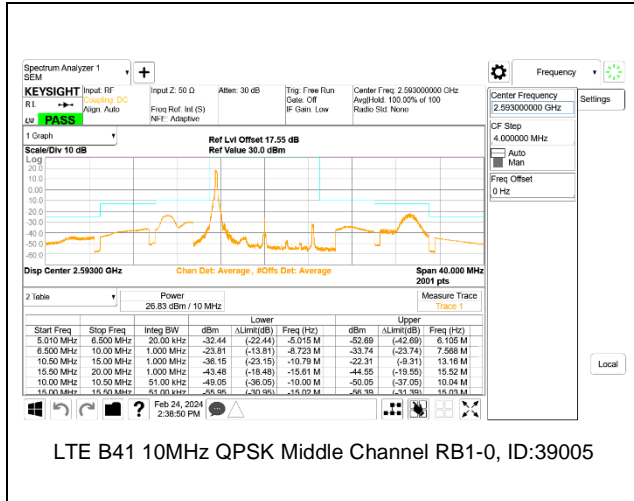

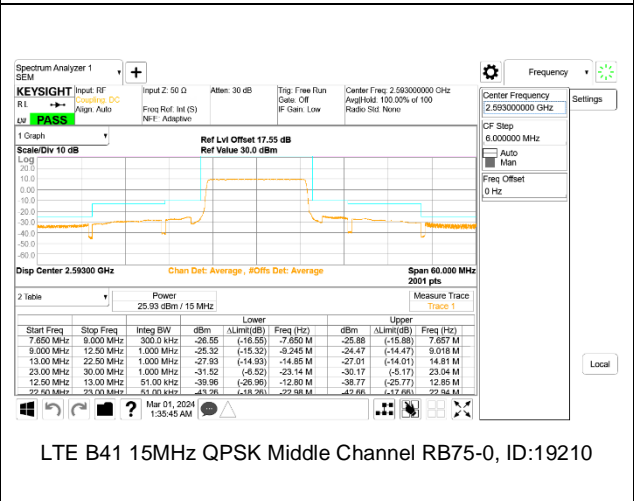
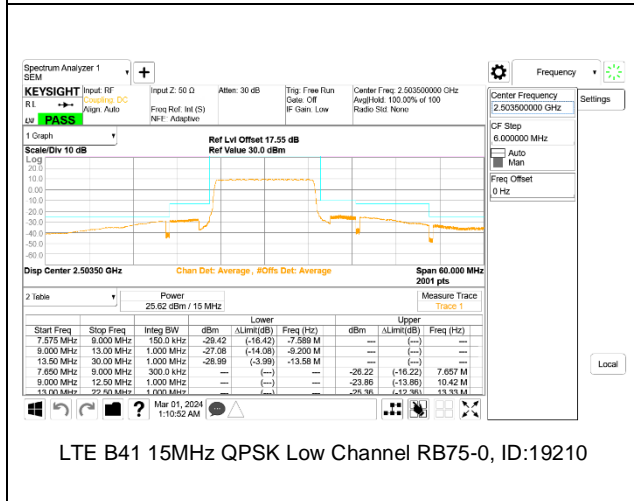
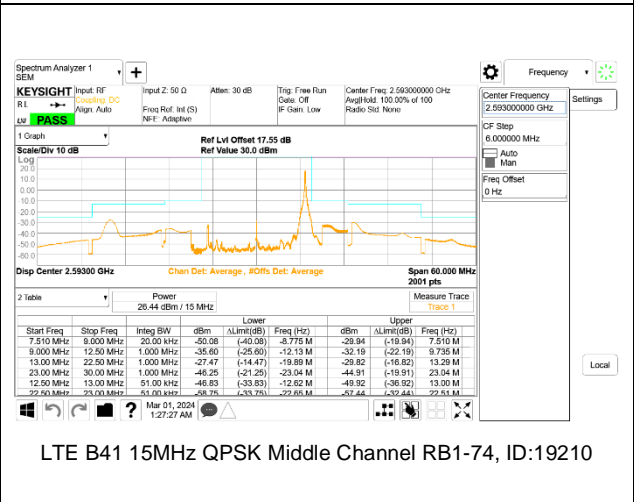
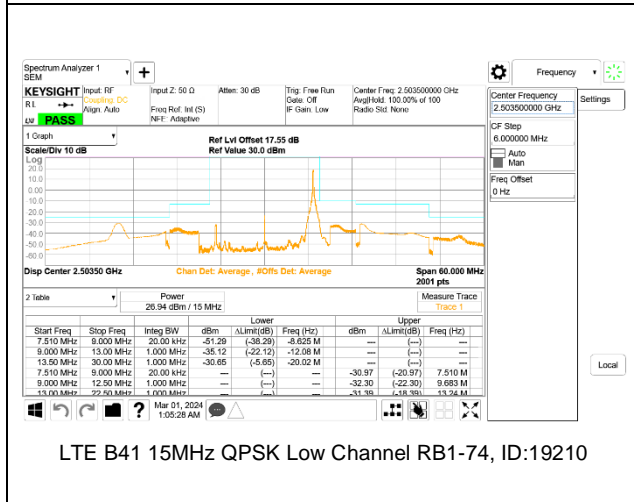
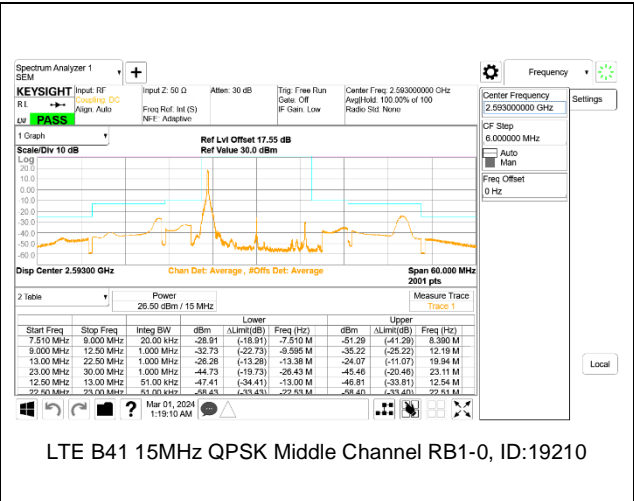
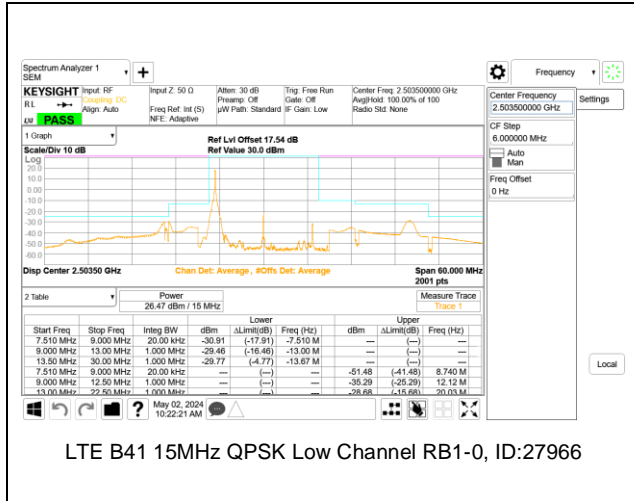



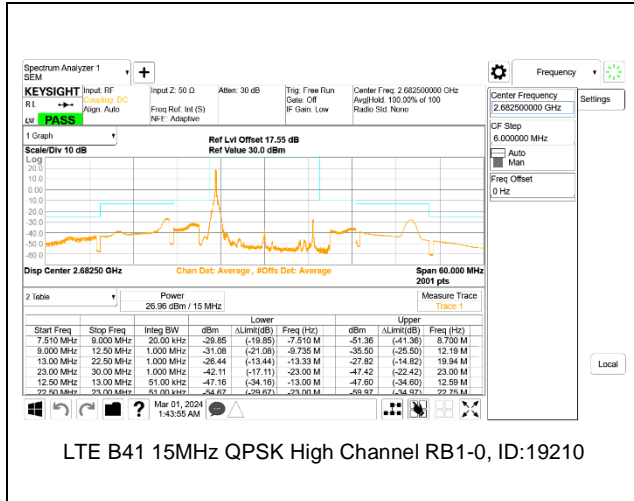

LTE B41 15MHz QPSK High Channel RB1-0, ID:19210

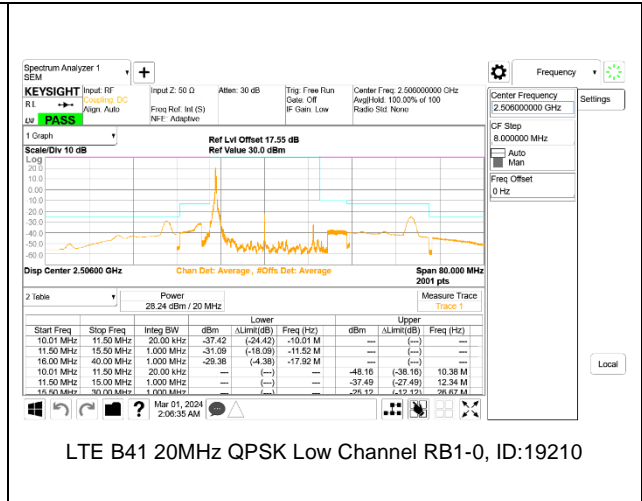

LTE B41 20MHz QPSK Low Channel RB1-0, ID:19210

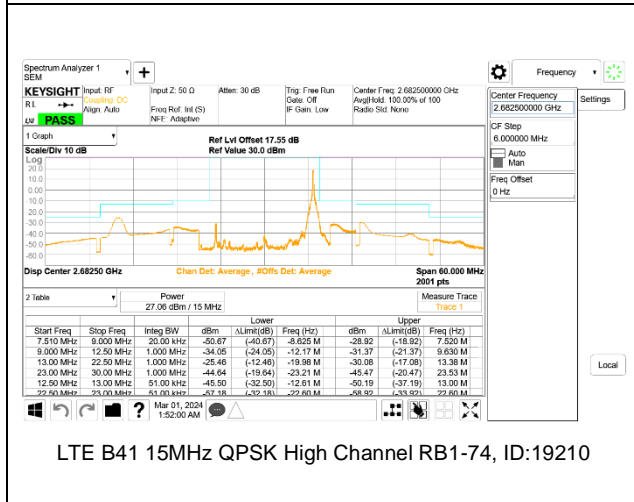

LTE B41 15MHz QPSK High Channel RB1-74, ID:19210

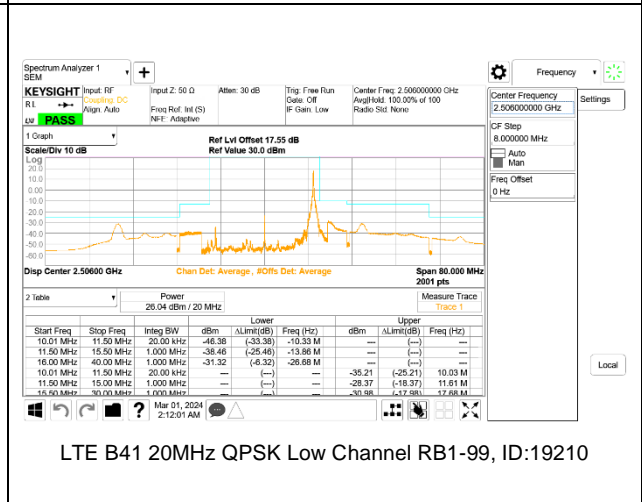

LTE B41 20MHz QPSK Low Channel RB1-99, ID:19210

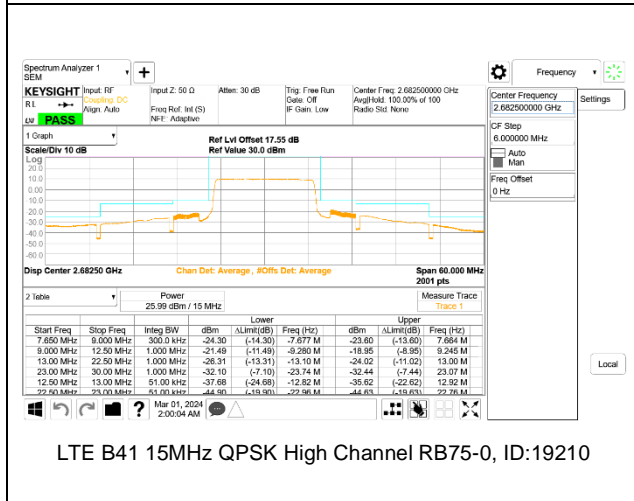

LTE B41 15MHz QPSK High Channel RB75-0, ID:19210

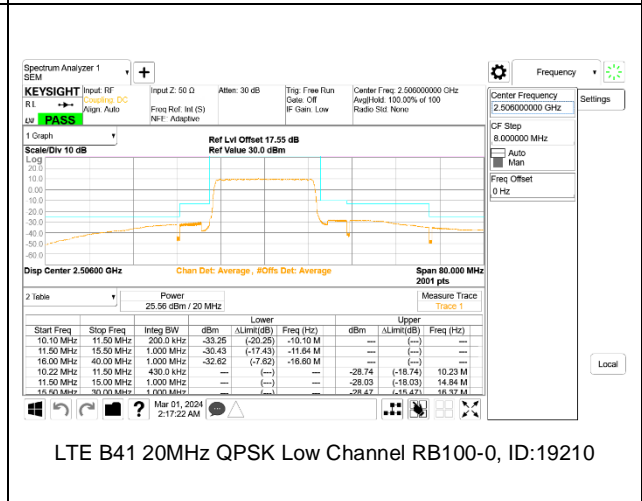

LTE B41 20MHz QPSK Low Channel RB100-0, ID:19210

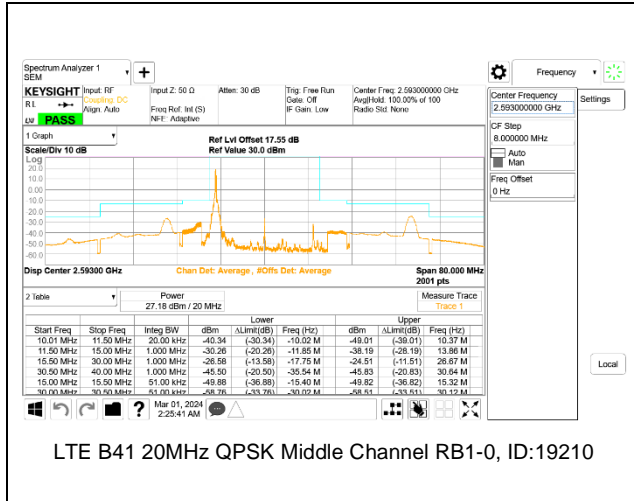

LTE B41 20MHz QPSK Middle Channel RB1-0, ID:19210

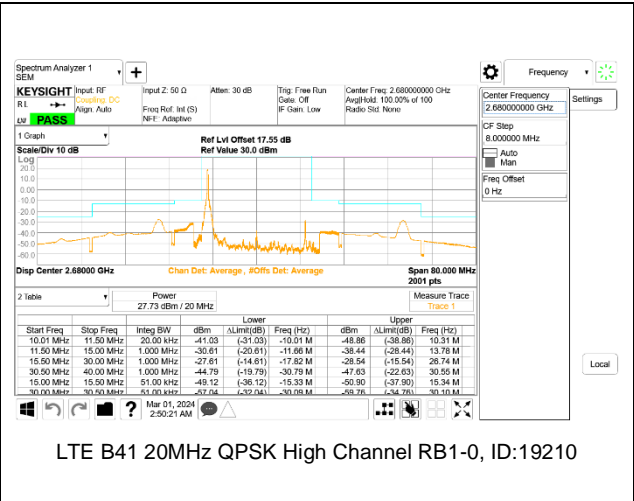

LTE B41 20MHz QPSK High Channel RB1-0, ID:19210

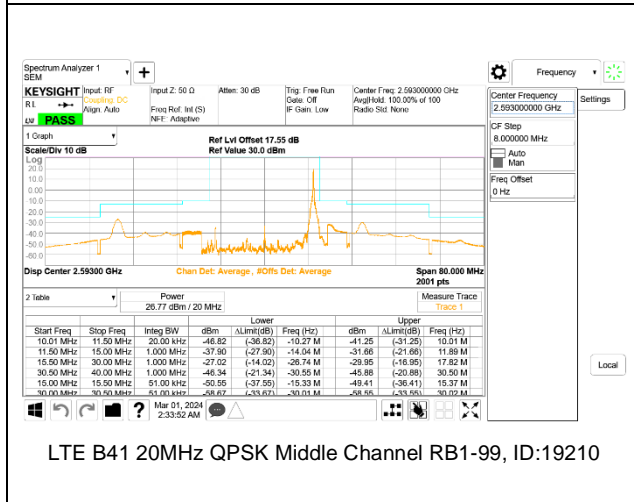

LTE B41 20MHz QPSK Middle Channel RB1-99, ID:19210

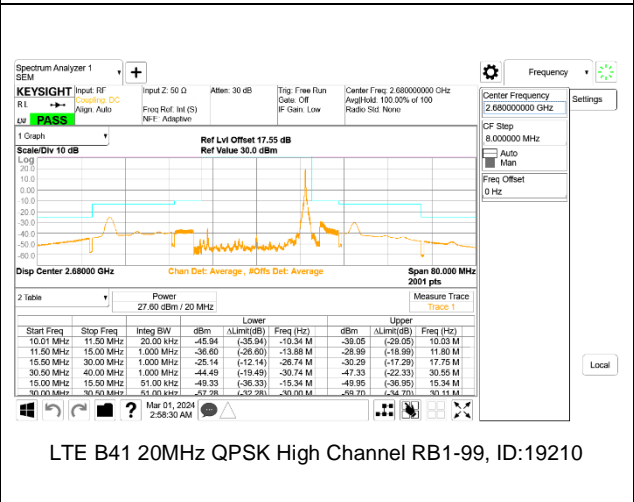

LTE B41 20MHz QPSK High Channel RB1-99, ID:19210

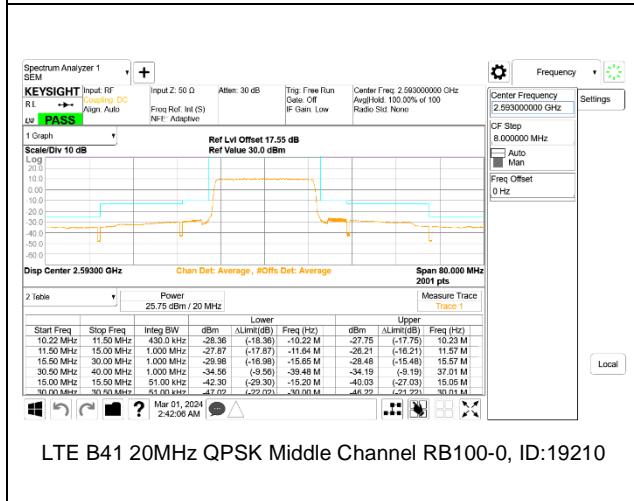

LTE B41 20MHz QPSK Middle Channel RB100-0, ID:19210

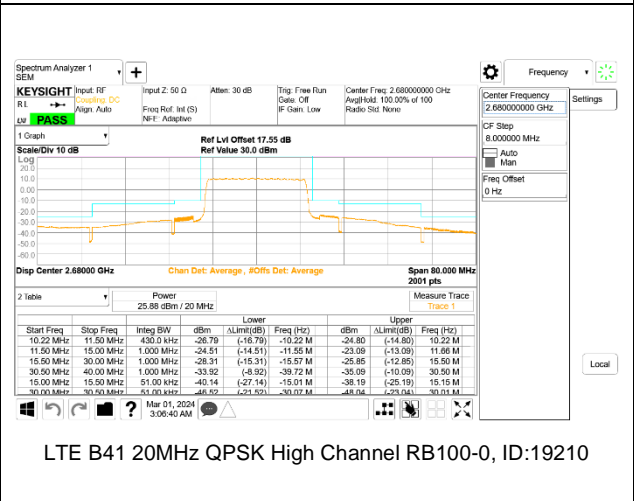

LTE B41 20MHz QPSK High Channel RB100-0, ID:19210

**5G NR n41 ADJACENT CHANNEL POWER (FCC)**

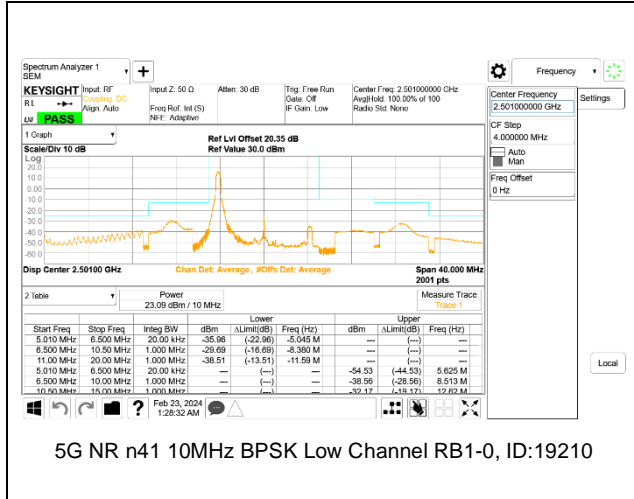

5G NR n41 10MHz BPSK Low Channel RB1-0, ID:19210

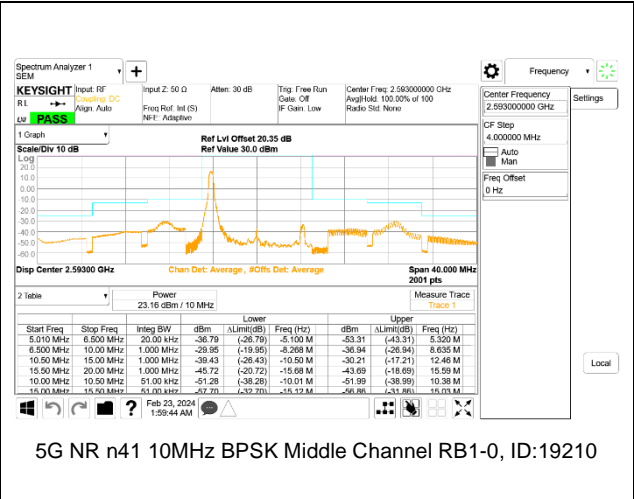

5G NR n41 10MHz BPSK Middle Channel RB1-0, ID:19210

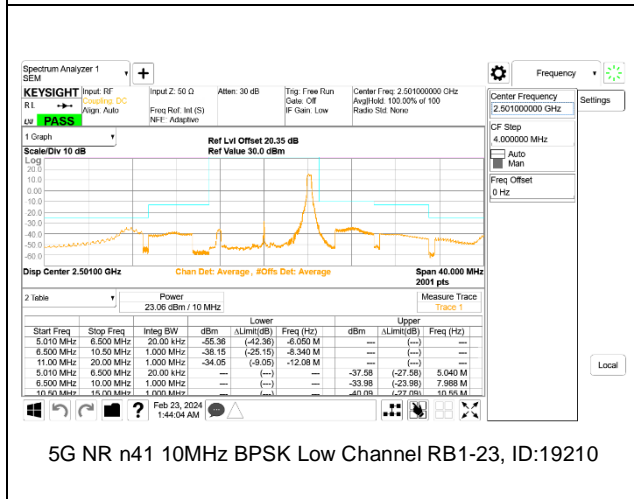

5G NR n41 10MHz BPSK Low Channel RB1-23, ID:19210

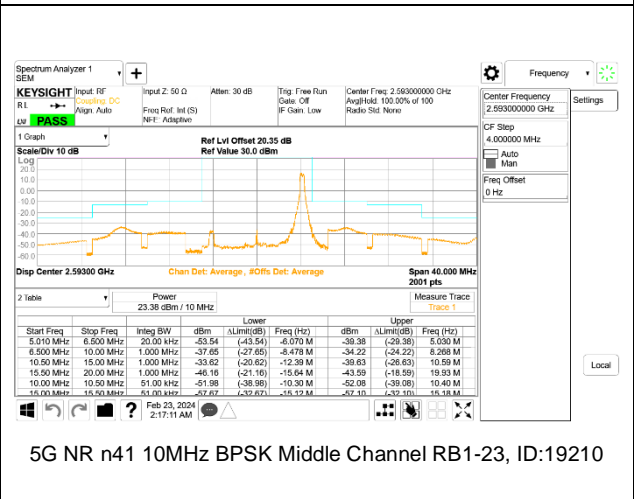

5G NR n41 10MHz BPSK Middle Channel RB1-23, ID:19210

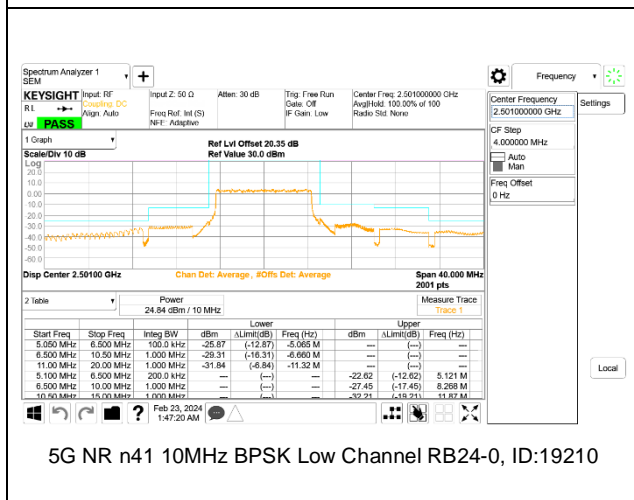

5G NR n41 10MHz BPSK Low Channel RB24-0, ID:19210

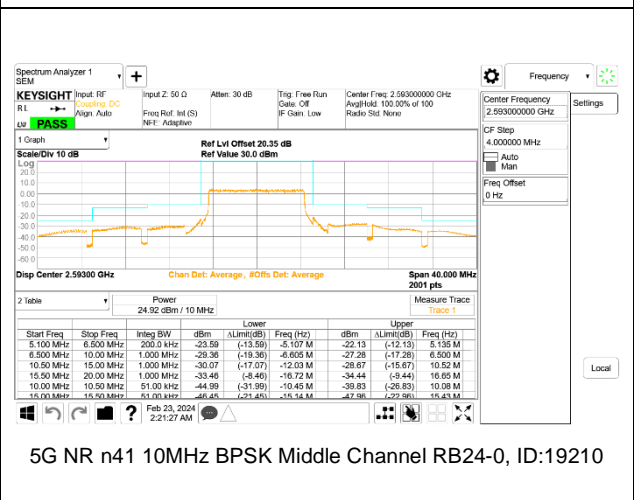

5G NR n41 10MHz BPSK Middle Channel RB24-0, ID:19210

