

5G NR n7 EMISSION MASK

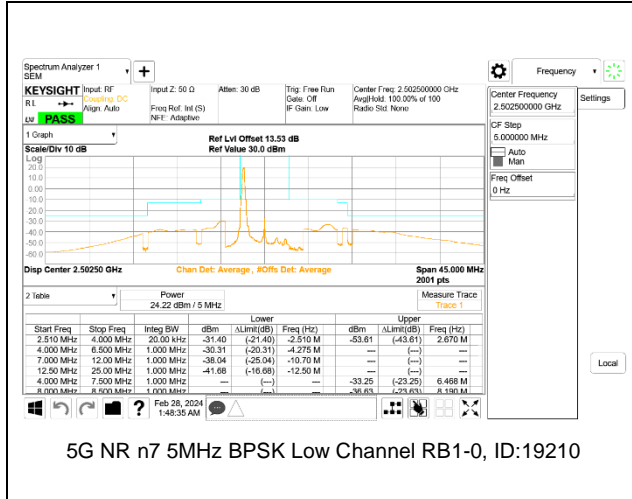

5G NR n7 5MHz BPSK Low Channel RB1-0, ID:19210

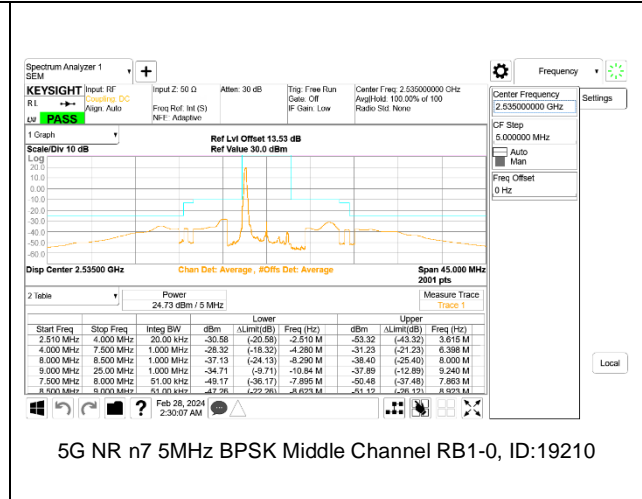

5G NR n7 5MHz BPSK Middle Channel RB1-0, ID:19210

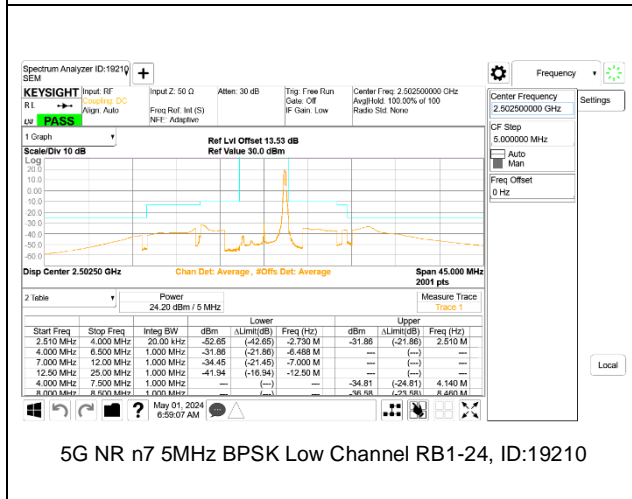

5G NR n7 5MHz BPSK Low Channel RB1-24, ID:19210

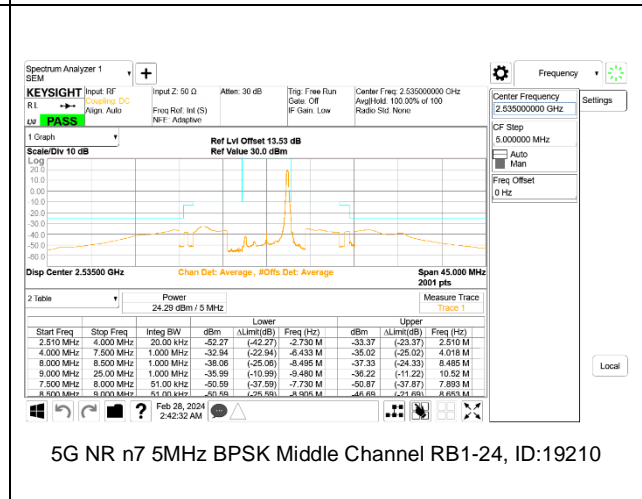

5G NR n7 5MHz BPSK Middle Channel RB1-24, ID:19210

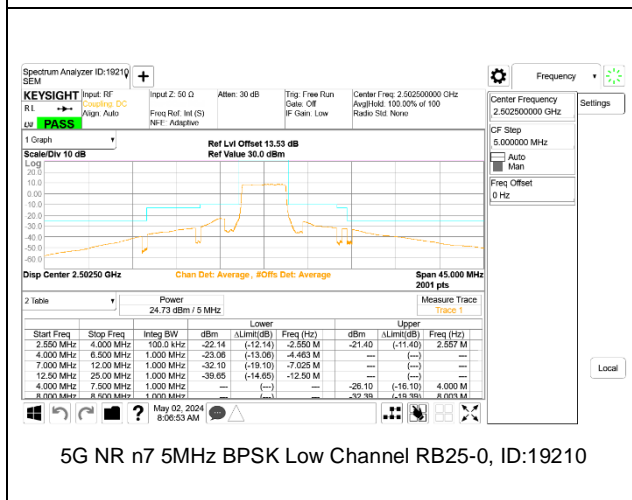

5G NR n7 5MHz BPSK Low Channel RB25-0, ID:19210

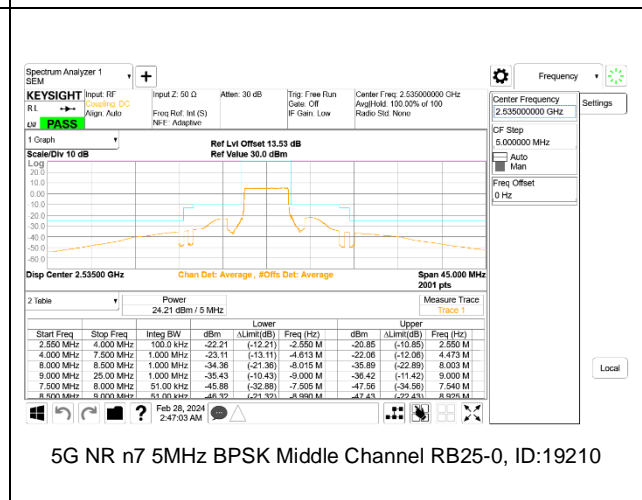

5G NR n7 5MHz BPSK Middle Channel RB25-0, ID:19210

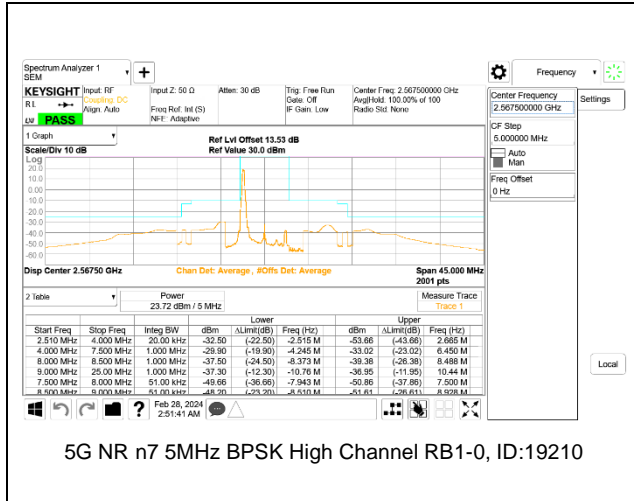

5G NR n7 5MHz BPSK High Channel RB1-0, ID:19210

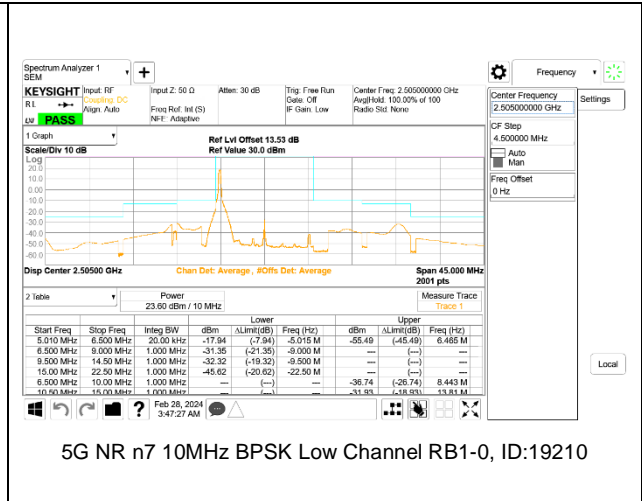

5G NR n7 10MHz BPSK Low Channel RB1-0, ID:19210

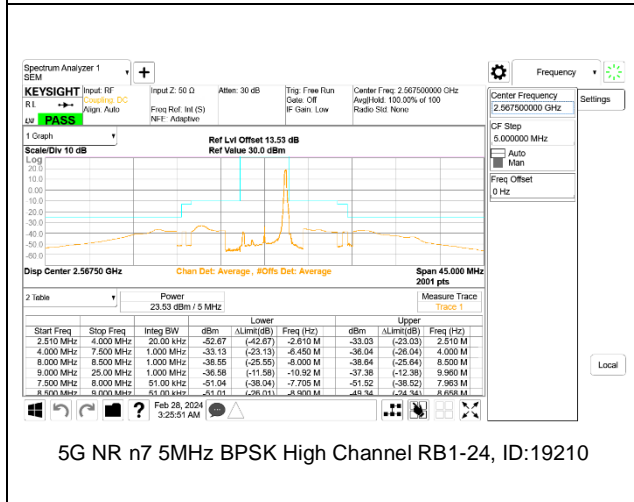

5G NR n7 5MHz BPSK High Channel RB1-24, ID:19210

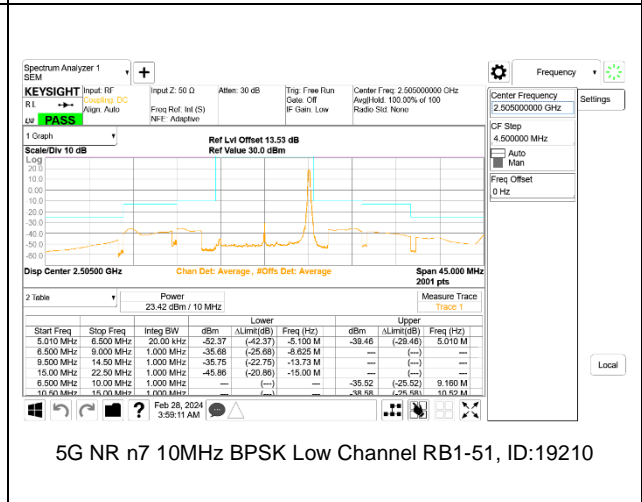

5G NR n7 10MHz BPSK Low Channel RB1-51, ID:19210

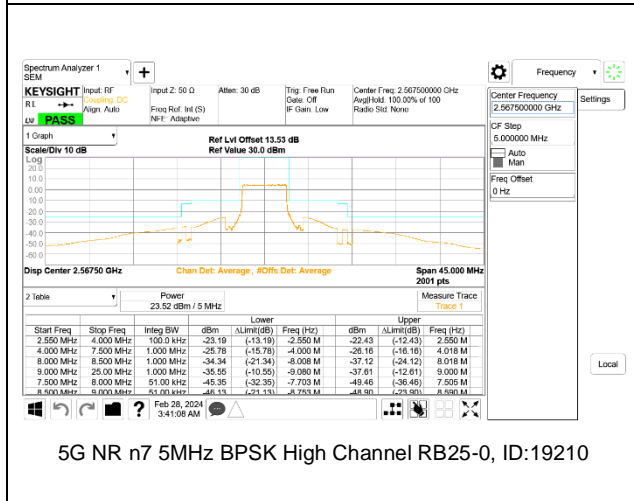

5G NR n7 5MHz BPSK High Channel RB25-0, ID:19210

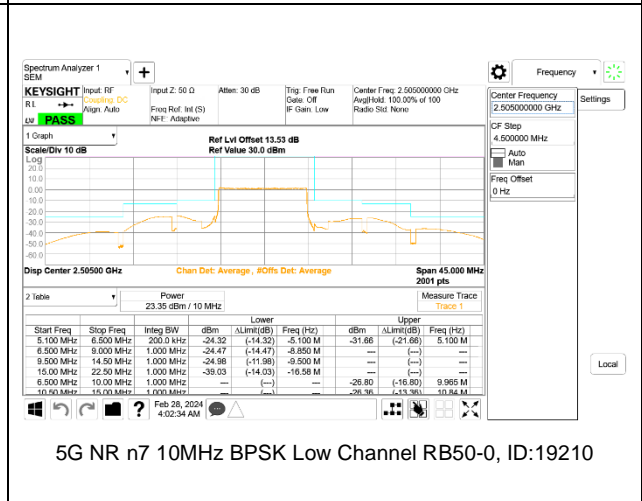

5G NR n7 10MHz BPSK Low Channel RB50-0, ID:19210

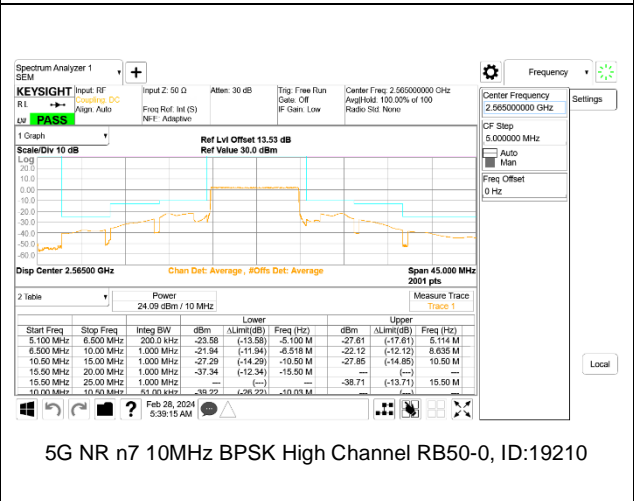
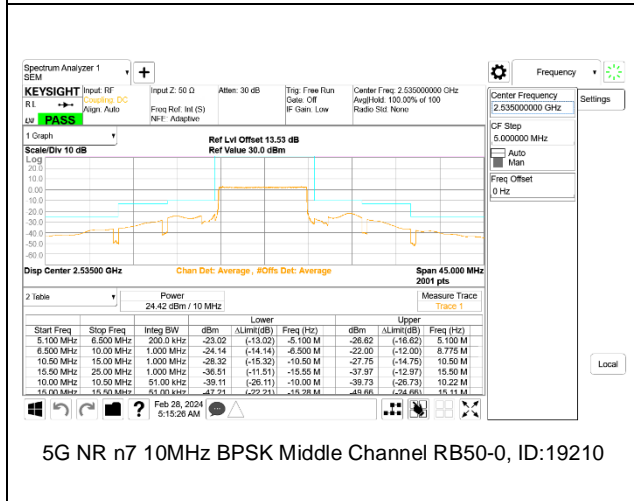
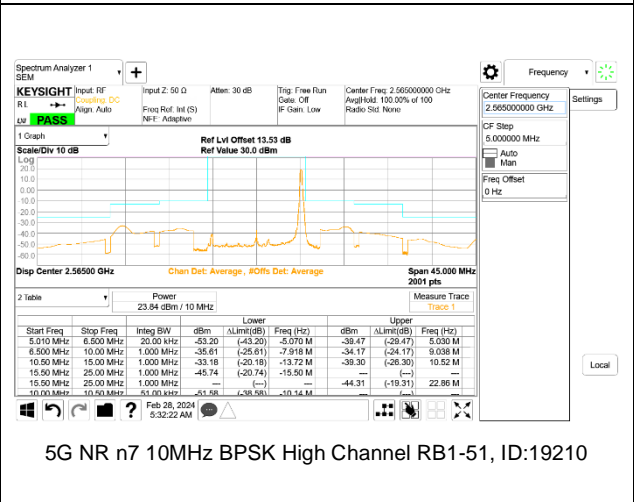
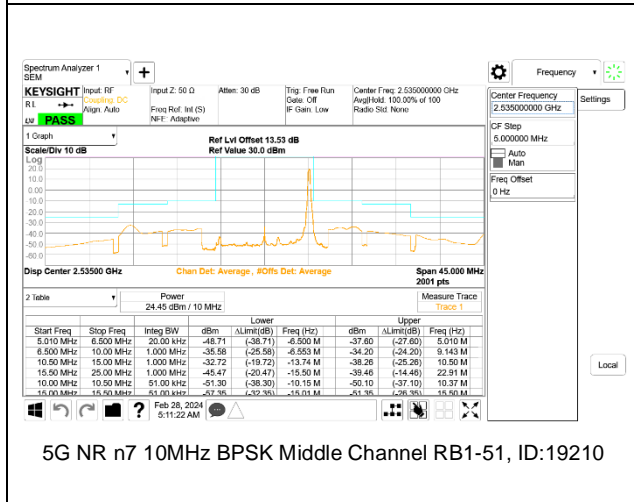
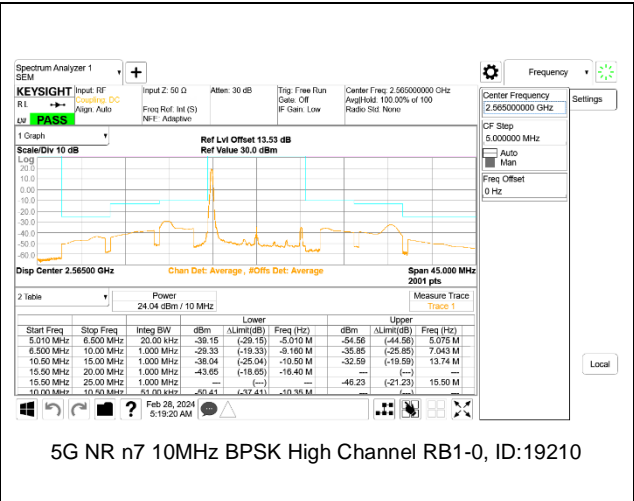
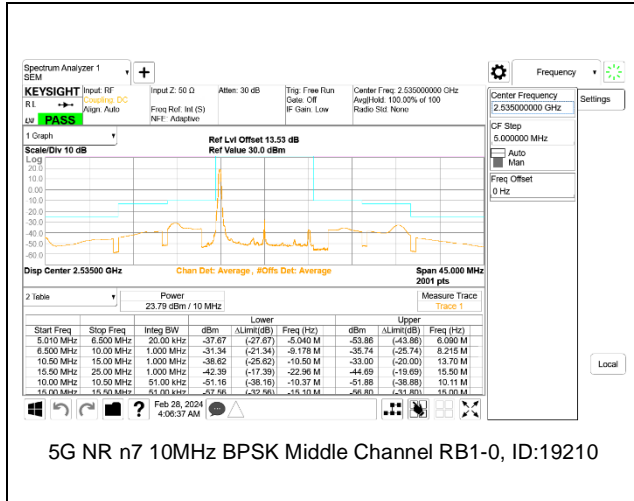

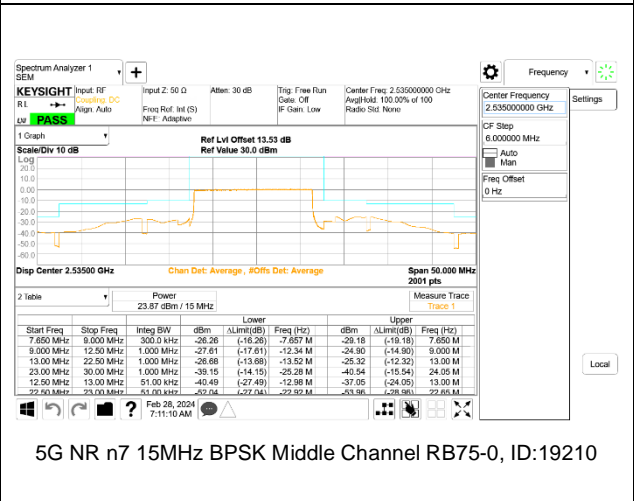
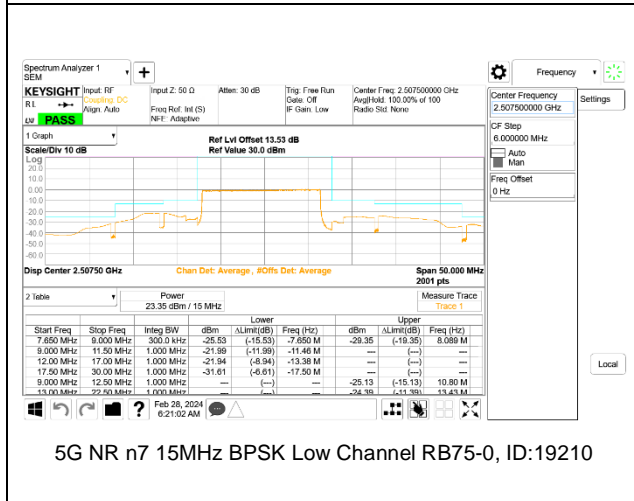
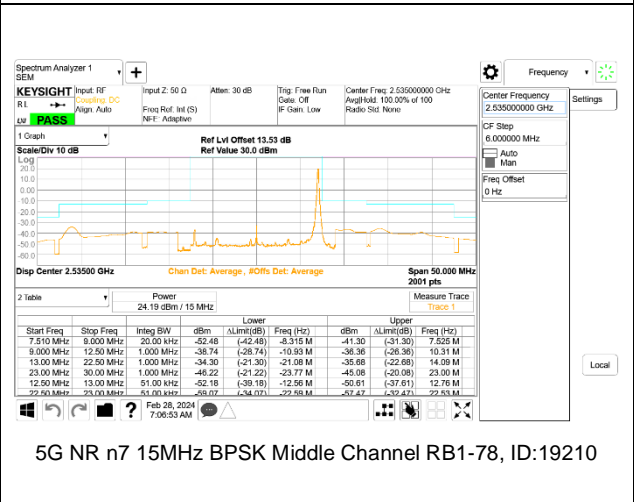
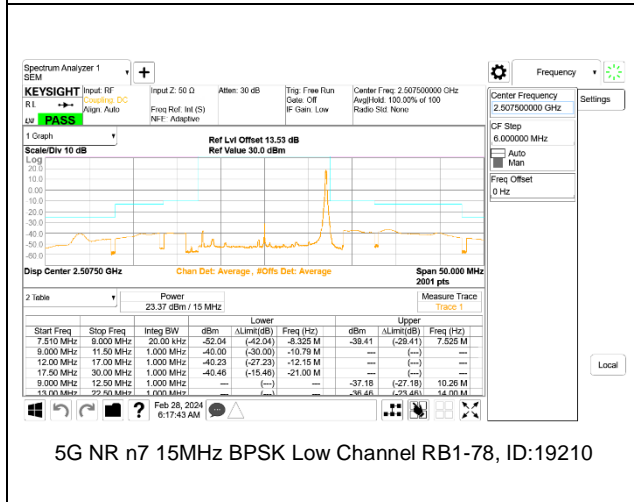
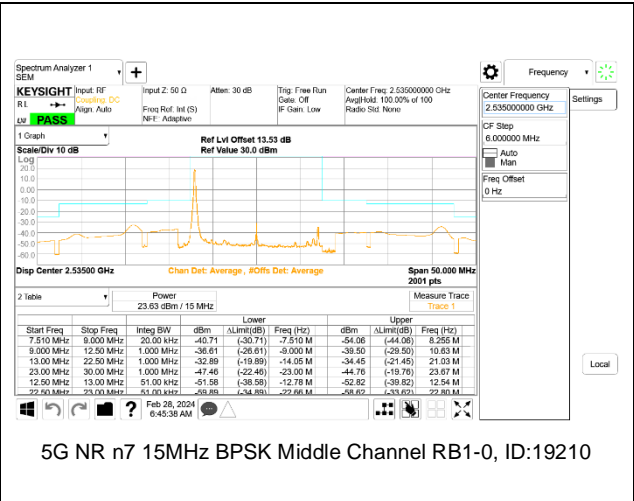
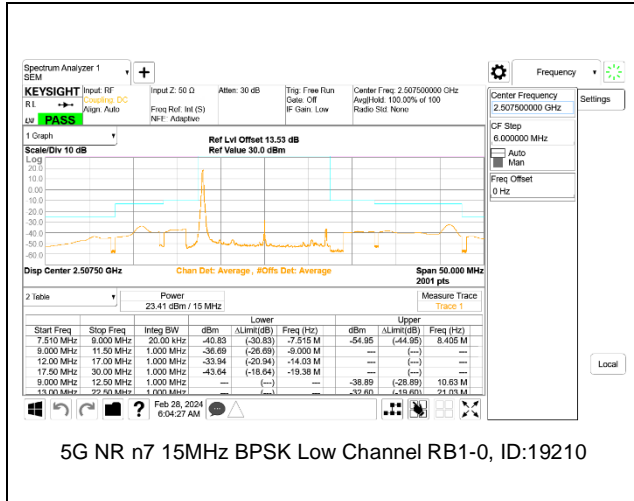

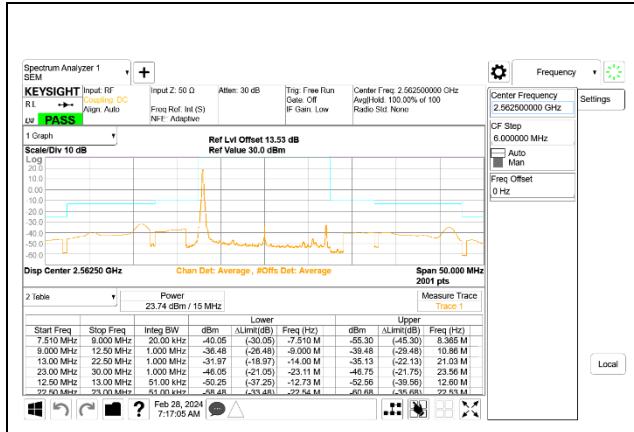

5G NR n7 15MHz BPSK High Channel RB1-0, ID:19210

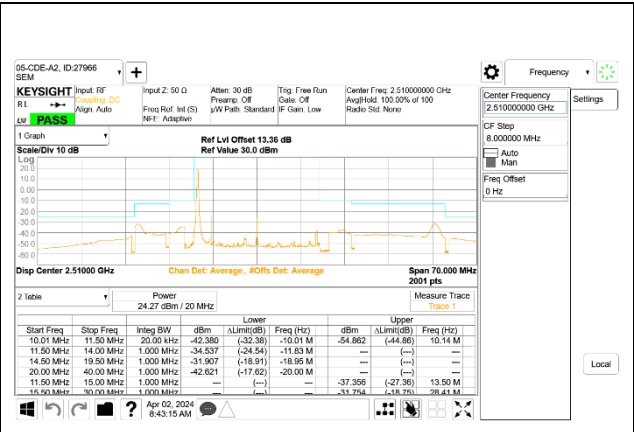

5G NR n7 20MHz BPSK Low Channel RB1-0, ID:27966

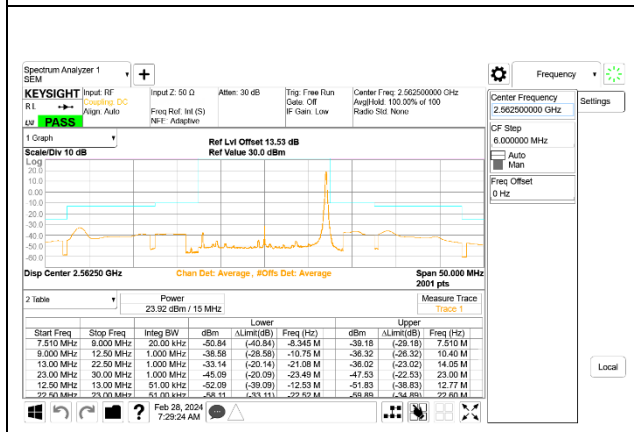

5G NR n7 15MHz BPSK High Channel RB1-78, ID:19210

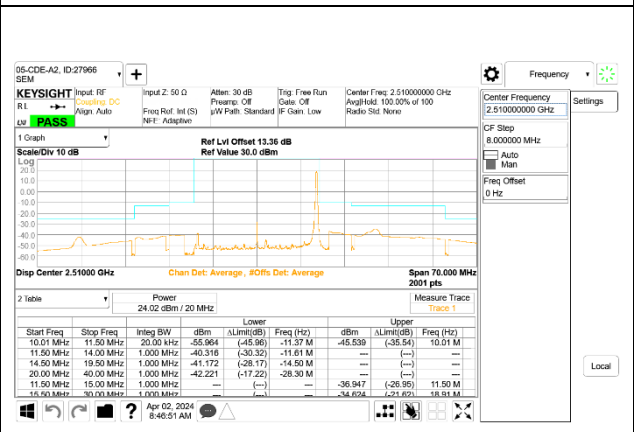

5G NR n7 20MHz BPSK Low Channel RB1-105, ID:27966

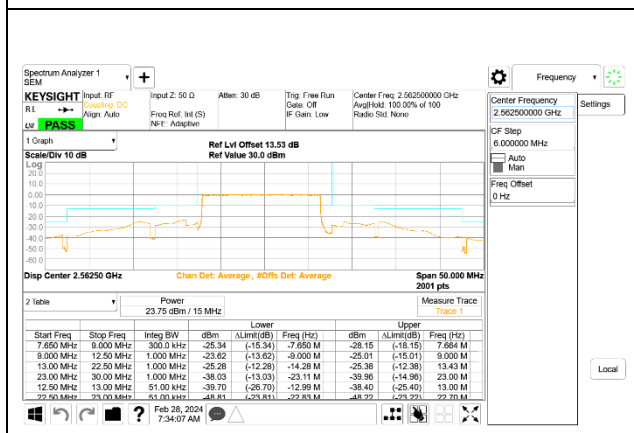

5G NR n7 15MHz BPSK High Channel RB75-0, ID:19210

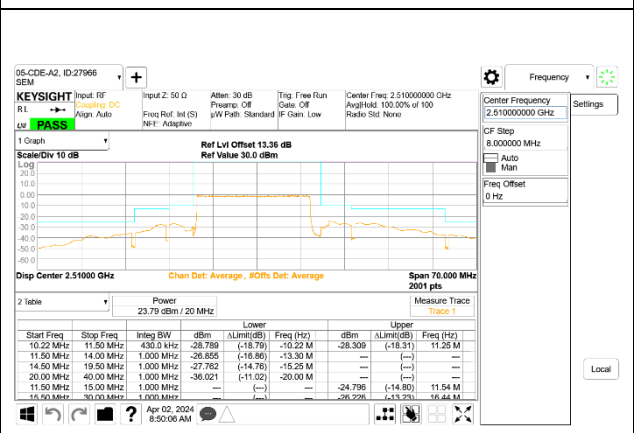

5G NR n7 20MHz BPSK Low Channel RB100-0, ID:27966

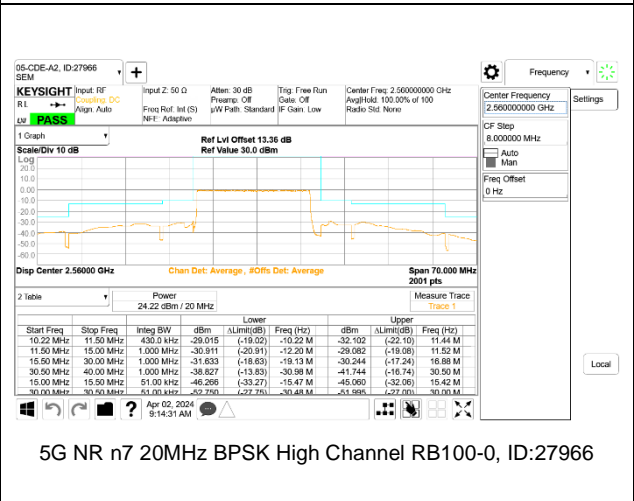
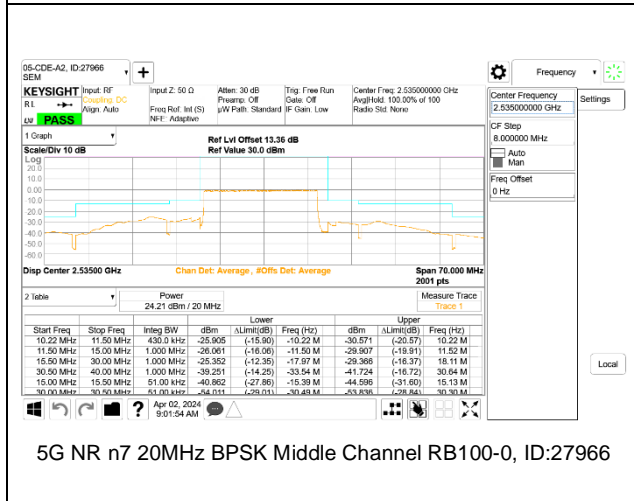
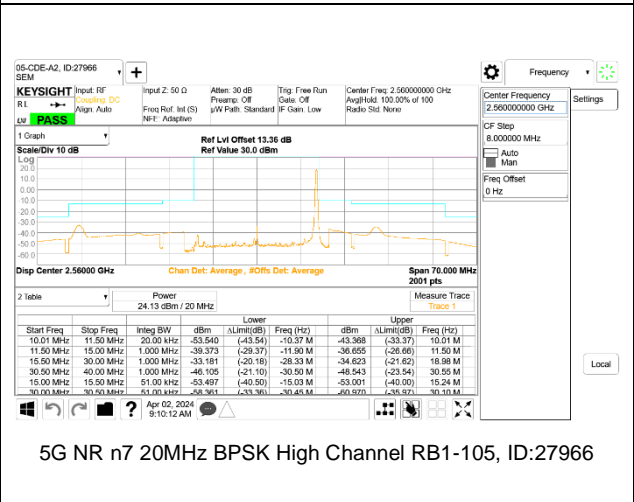
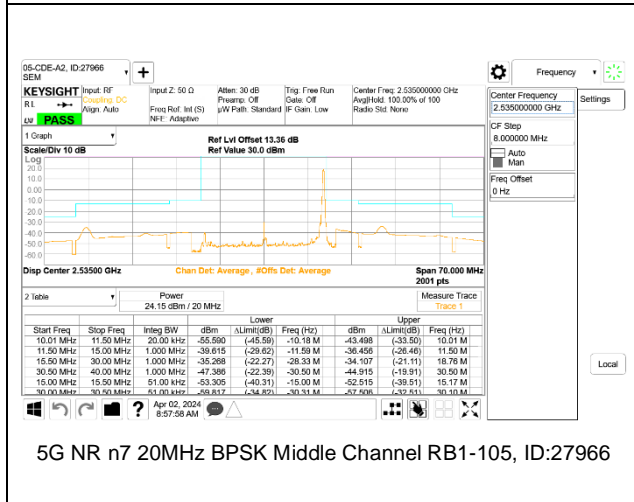
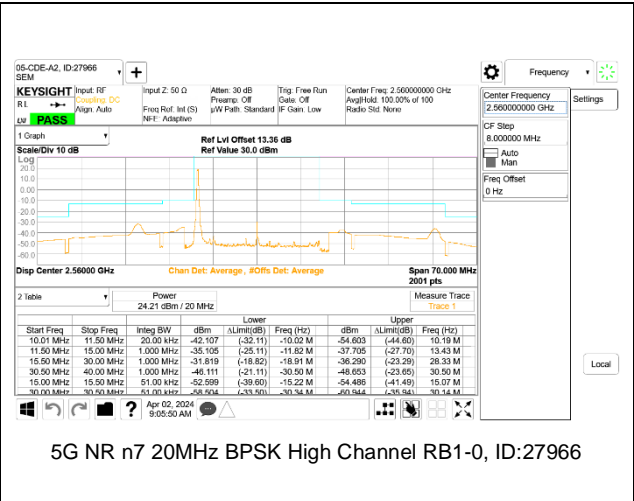
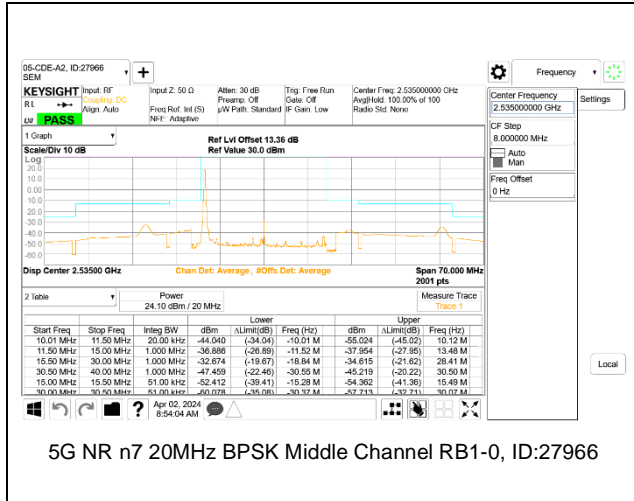

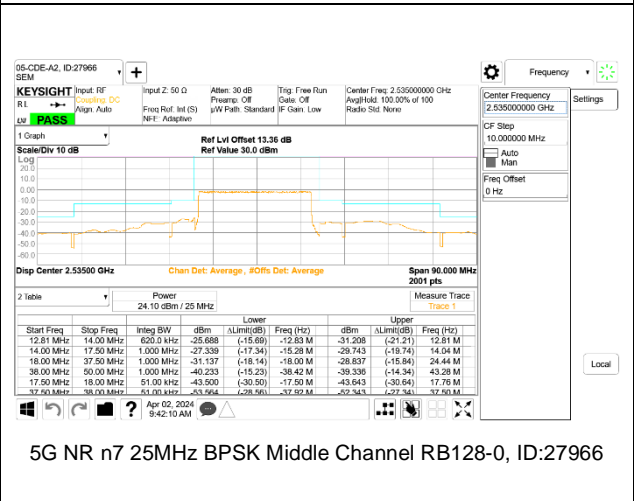
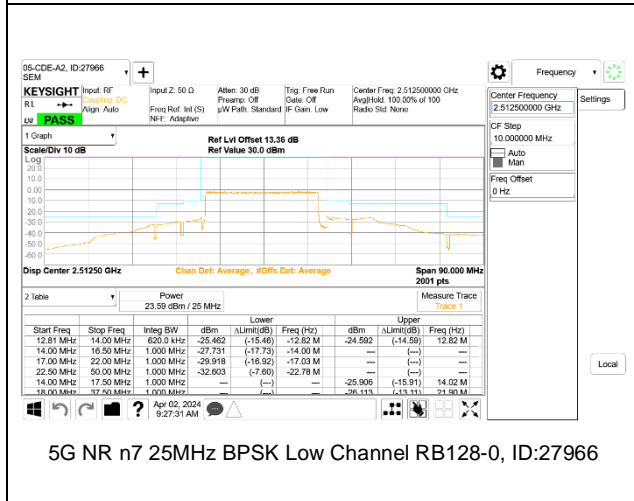
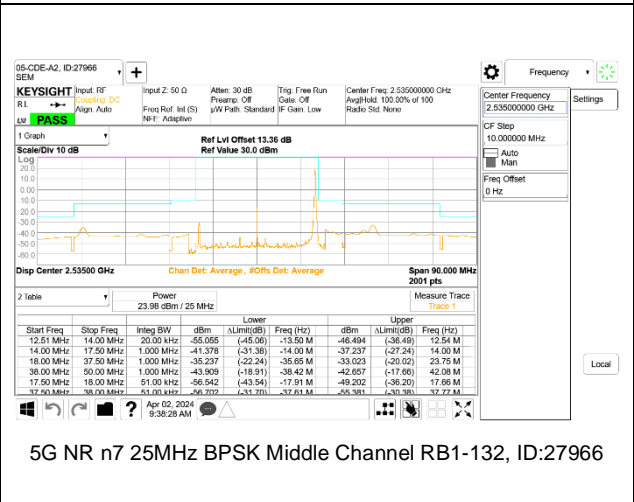
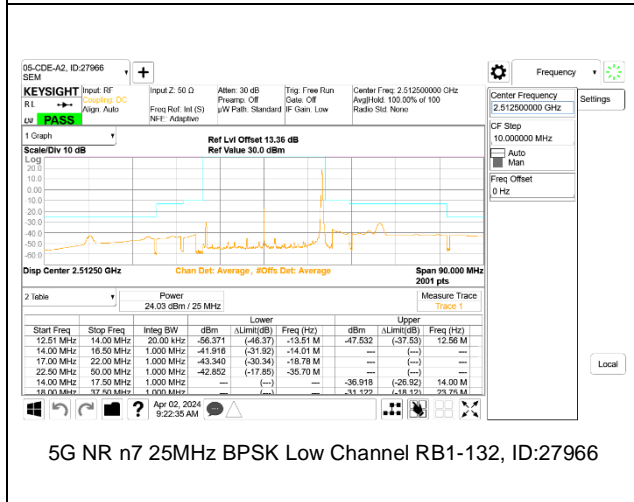
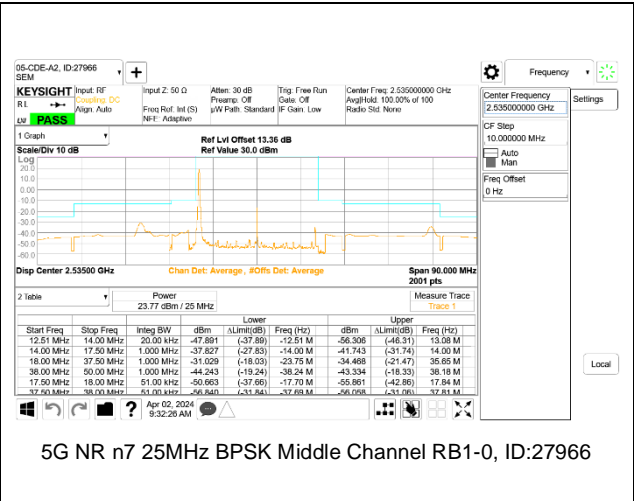
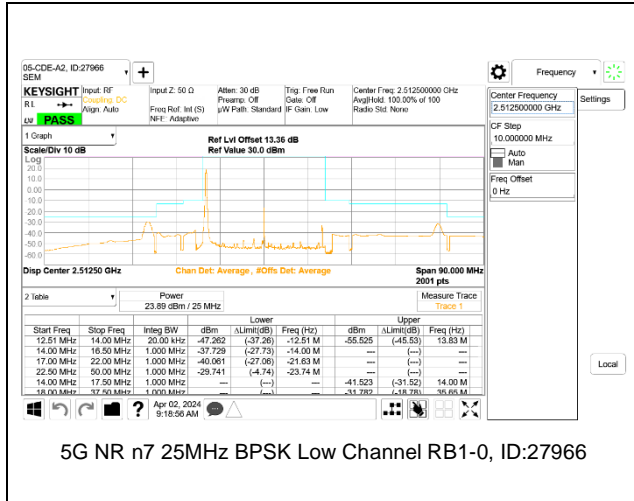

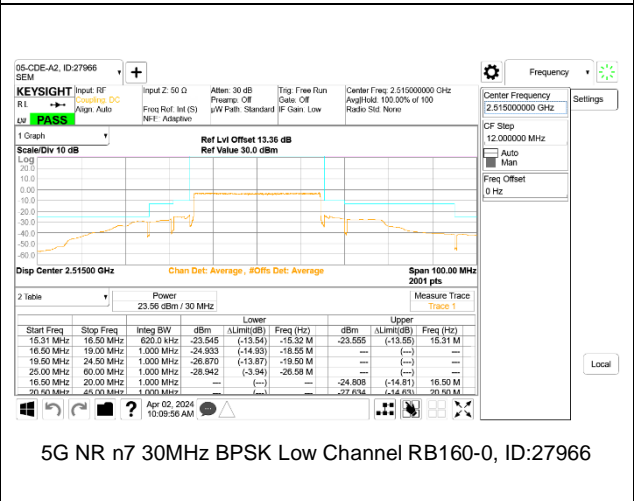
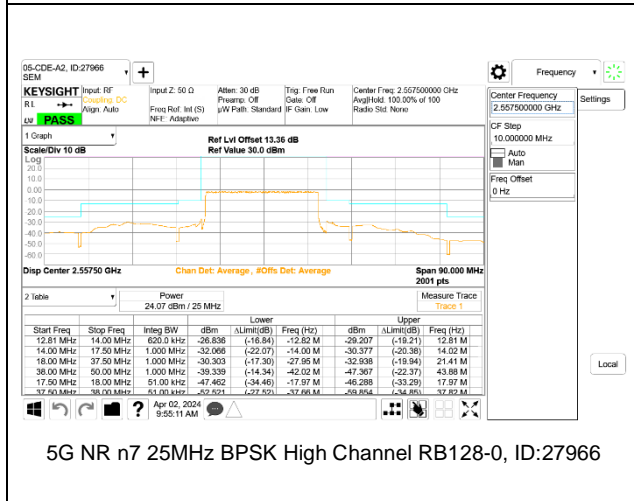
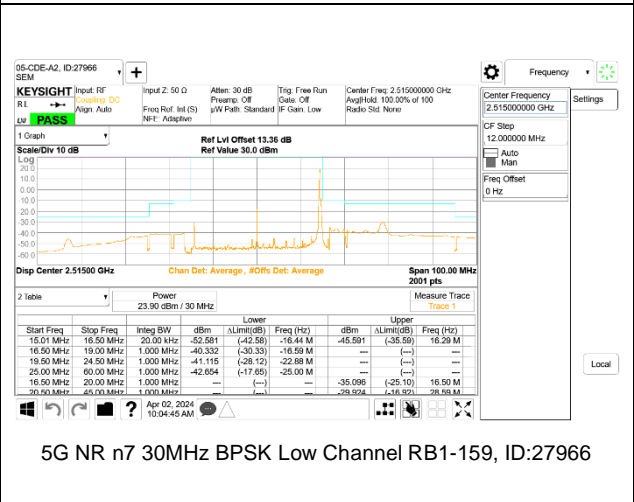
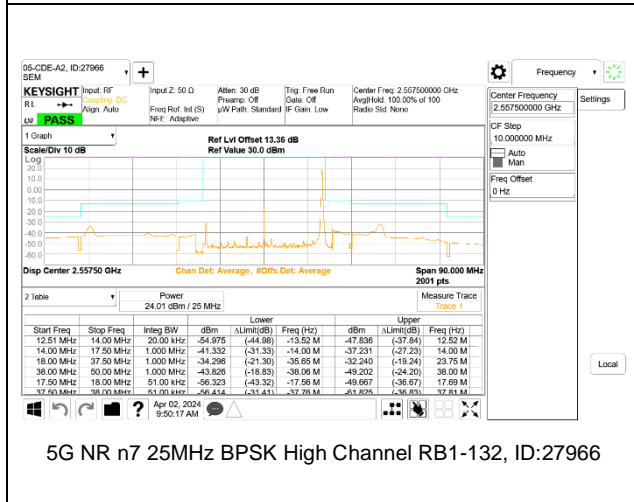
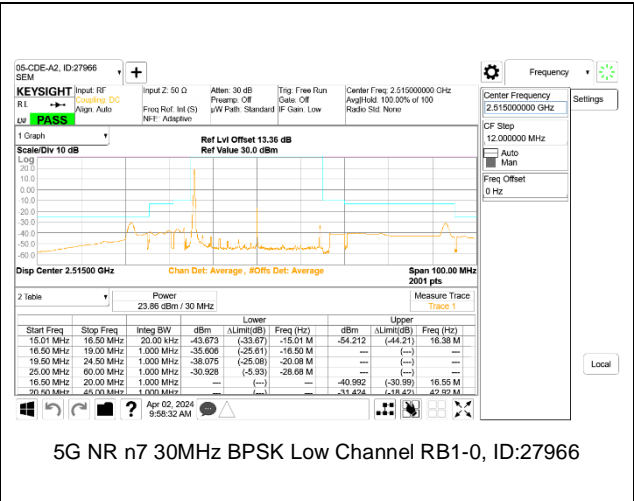
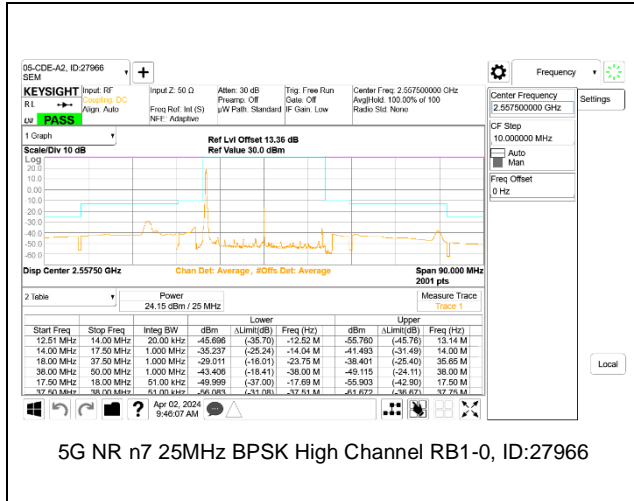

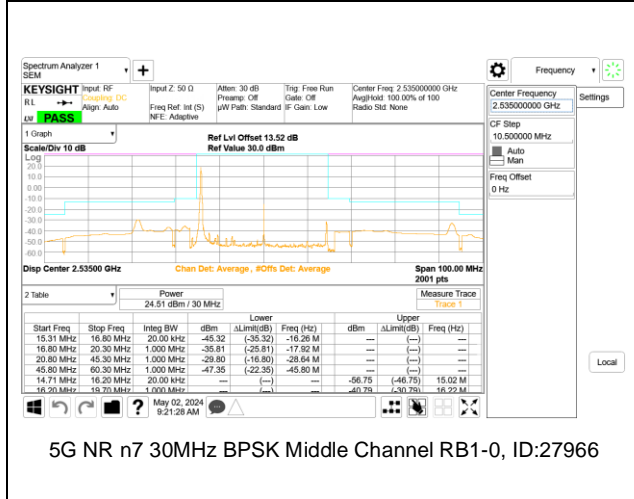

5G NR n7 30MHz BPSK Middle Channel RB1-0, ID:27966

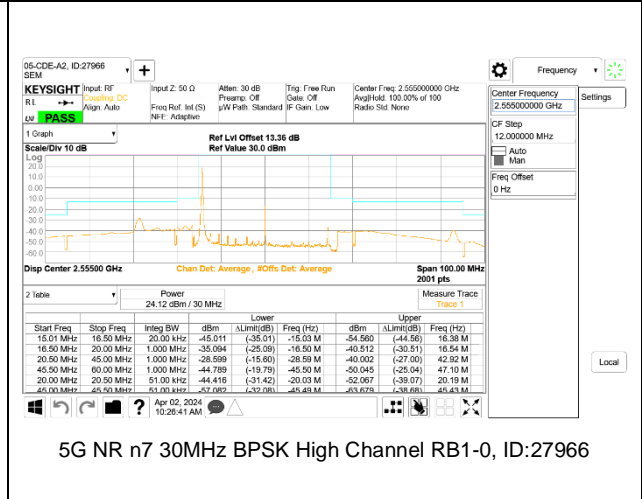

5G NR n7 30MHz BPSK High Channel RB1-0, ID:27966

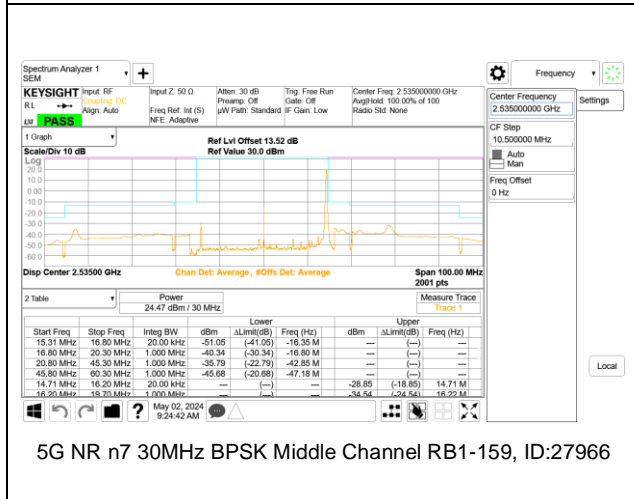

5G NR n7 30MHz BPSK Middle Channel RB1-159, ID:27966

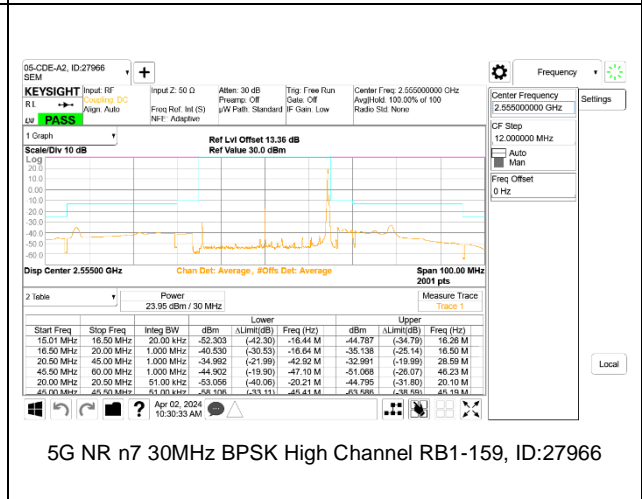

5G NR n7 30MHz BPSK High Channel RB1-159, ID:27966

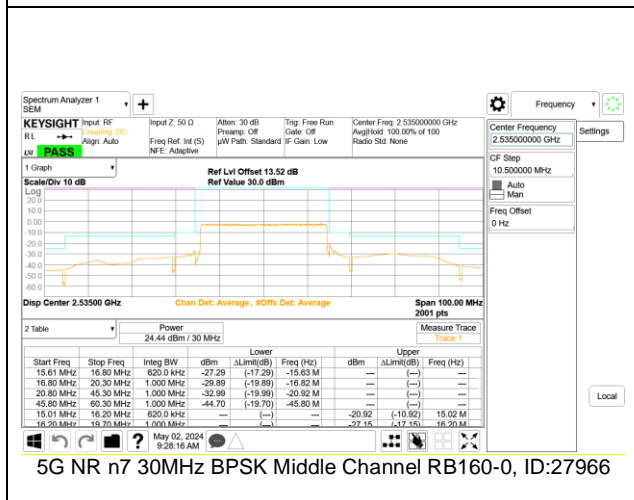

5G NR n7 30MHz BPSK Middle Channel RB160-0, ID:27966

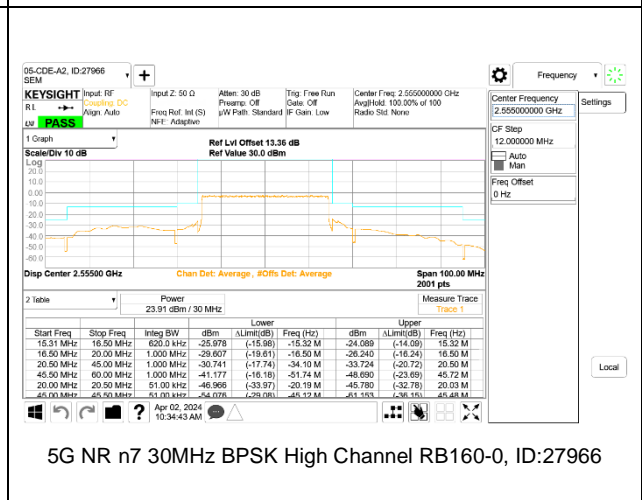

5G NR n7 30MHz BPSK High Channel RB160-0, ID:27966

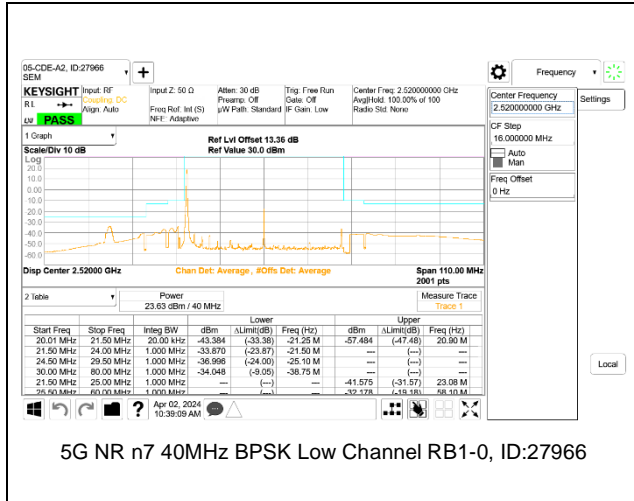

5G NR n7 40MHz BPSK Low Channel RB1-0, ID:27966

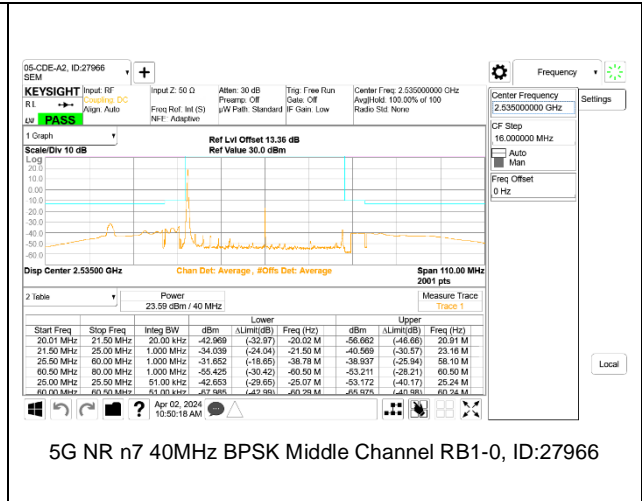

5G NR n7 40MHz BPSK Middle Channel RB1-0, ID:27966

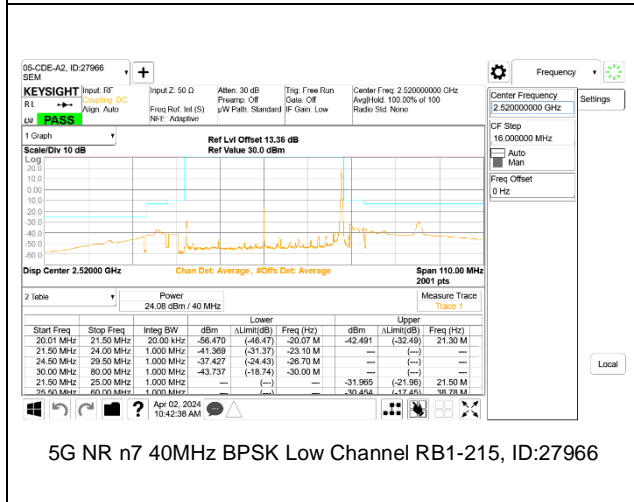

5G NR n7 40MHz BPSK Low Channel RB1-215, ID:27966

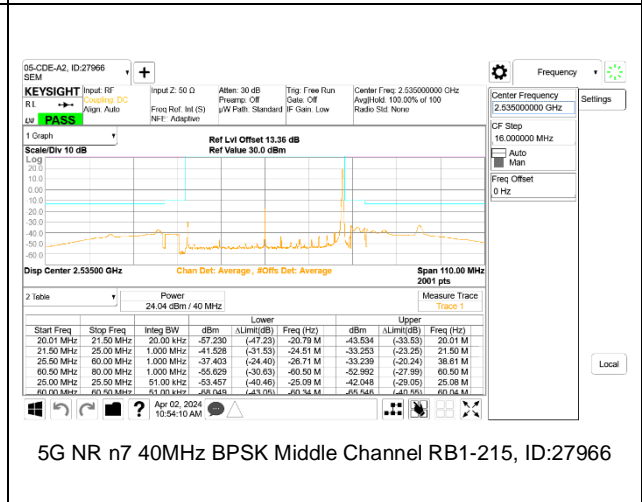

5G NR n7 40MHz BPSK Middle Channel RB1-215, ID:27966

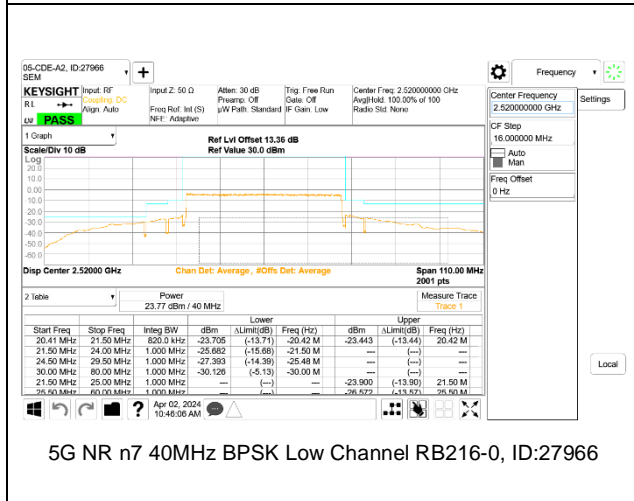

5G NR n7 40MHz BPSK Low Channel RB216-0, ID:27966

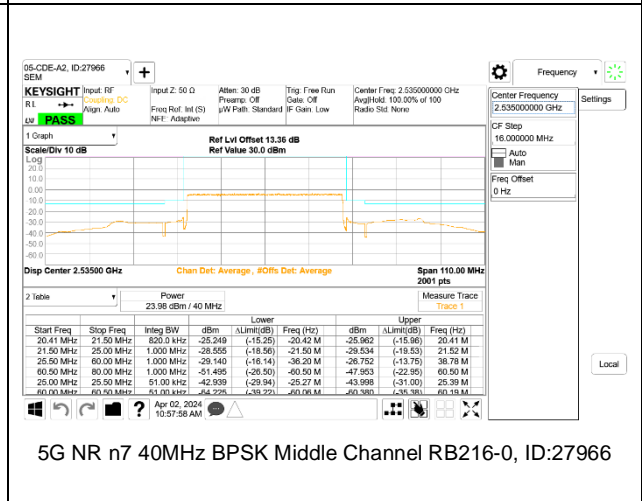

5G NR n7 40MHz BPSK Middle Channel RB216-0, ID:27966

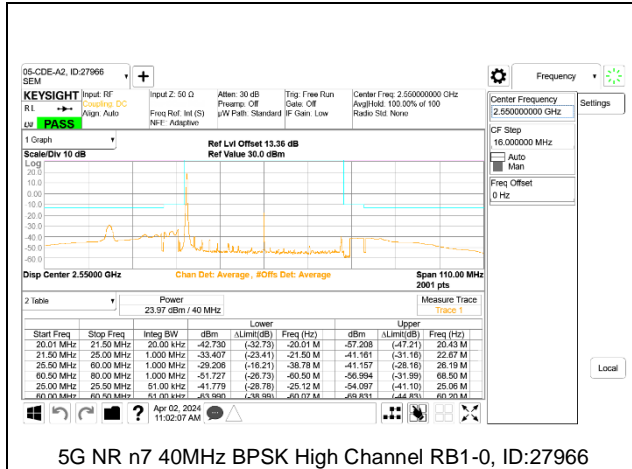

5G NR n7 40MHz BPSK High Channel RB1-0, ID:27966

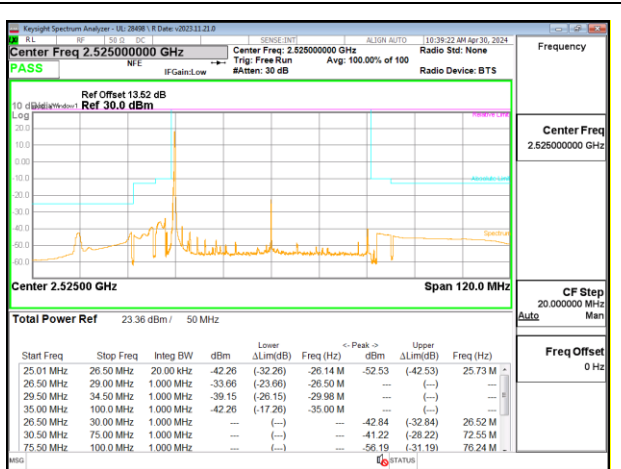

5G NR n7 50MHz BPSK Low Channel RB1-0, ID:28498

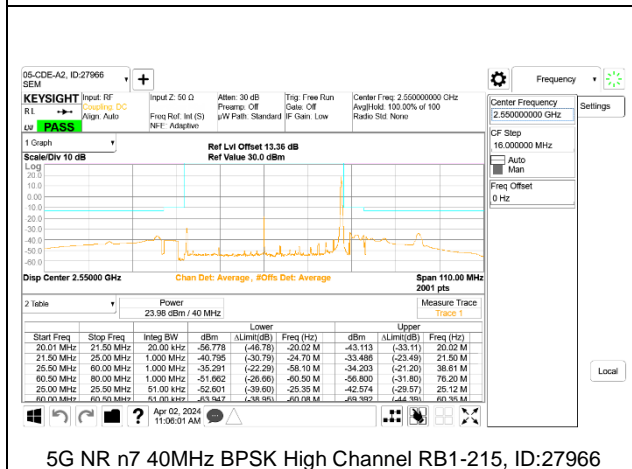

5G NR n7 40MHz BPSK High Channel RB1-215, ID:27966

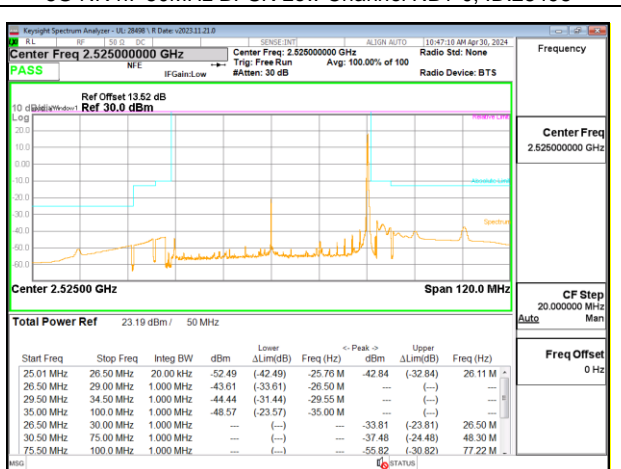

5G NR n7 50MHz BPSK Low Channel RB1-271, ID: 28498

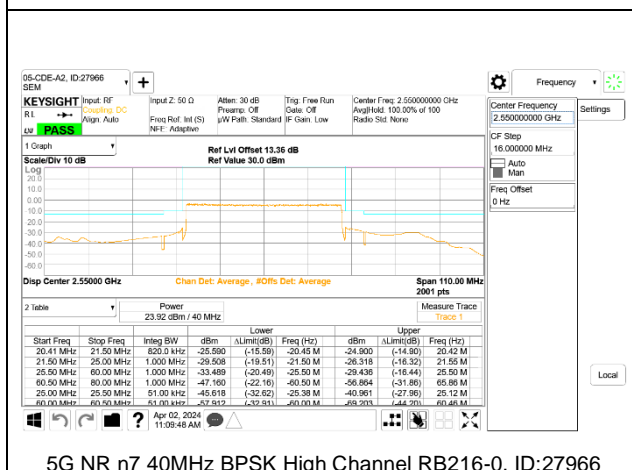

5G NR n7 40MHz BPSK High Channel RB216-0, ID:27966

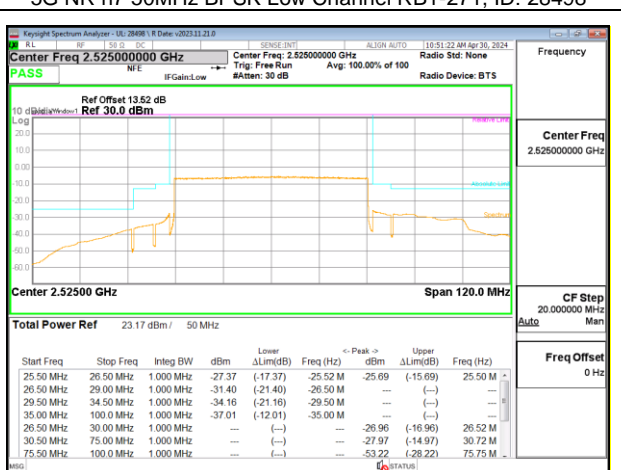

5G NR n7 50MHz BPSK Middle Channel RB270-0, ID: 28498

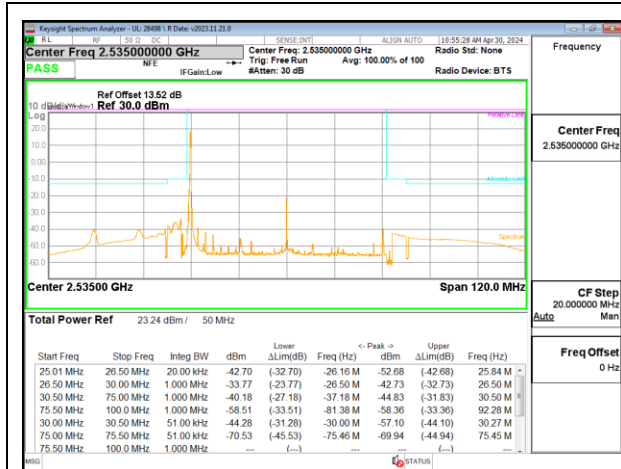

5G NR n7 50MHz BPSK Middle Channel RB1-0, ID: 28498

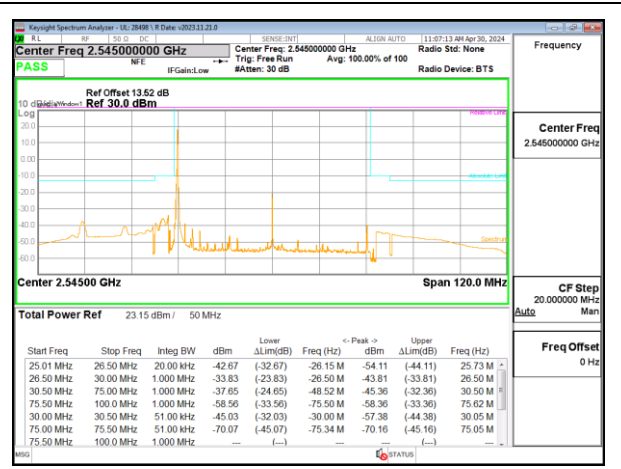

5G NR n7 50MHz BPSK High Channel RB1-0, ID: 28498

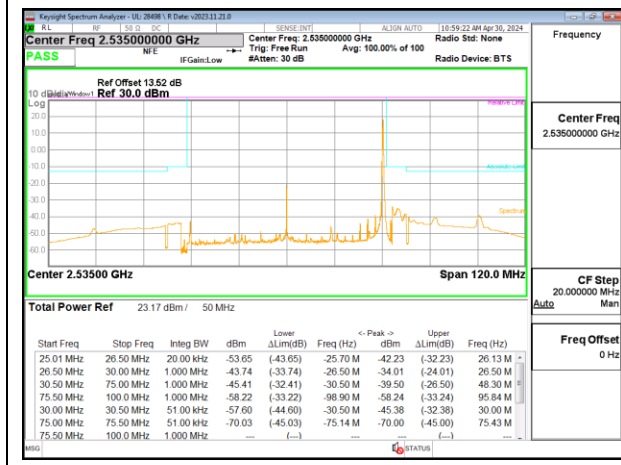

5G NR n7 50MHz BPSK Middle Channel RB1-271, ID: 28498

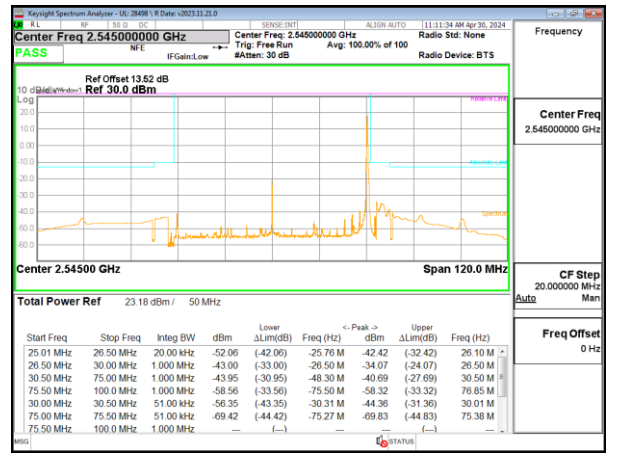

5G NR n7 50MHz BPSK High Channel RB1-271, ID: 28498

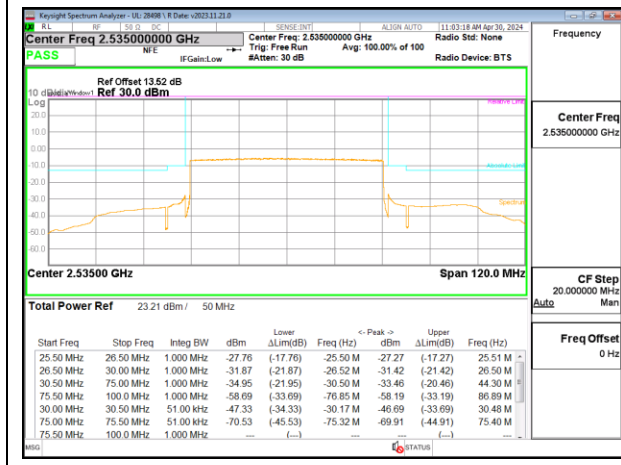

5G NR n7 50MHz BPSK High Channel RB270-0, ID: 28498

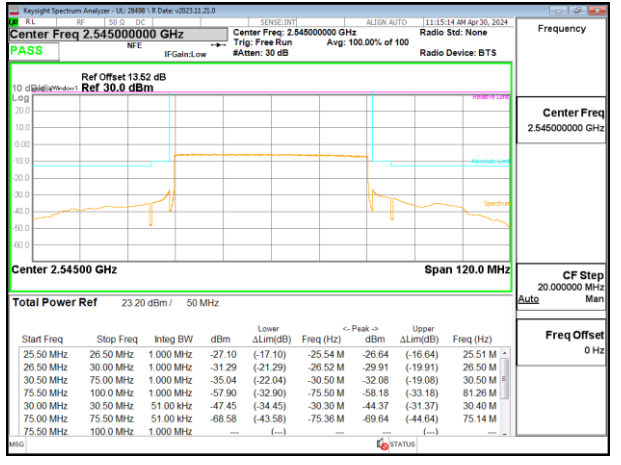

5G NR n7 50MHz BPSK High Channel RB270-0, ID: 28498

9.2.3. LTE BAND 12 AND 5G NR n12

LIMITS

FCC: §27.53

(g) For operations in the 600 MHz band and the 698-746 MHz band, the power of any emission outside a licensee's frequency band(s) of operation shall be attenuated below the transmitter power (P) within the licensed band(s) of operation, measured in watts, by at least $43 + 10 \log (P)$ dB. Compliance with this provision is based on the use of measurement instrumentation employing a resolution bandwidth of 100 kilohertz or greater. However, in the 100 kilohertz bands immediately outside and adjacent to a licensee's frequency block, a resolution bandwidth of at least 30 kHz may be employed.