

9.1.8. LTE BAND 26 AND 5G NR n26 (PART 90S)

LTE BAND 26 (PART 90S)

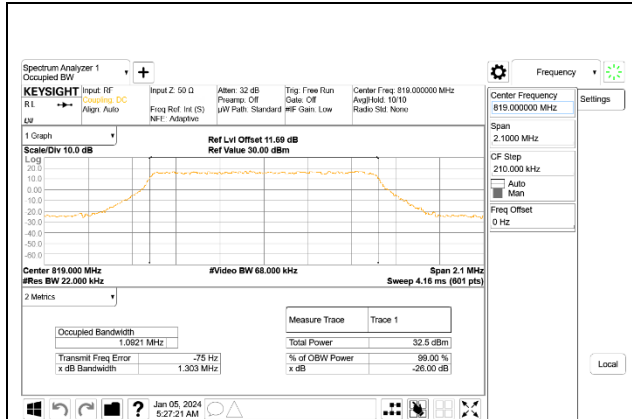

LTE B26 1.4MHz QPSK Middle Channel RB6-0, ID:27979

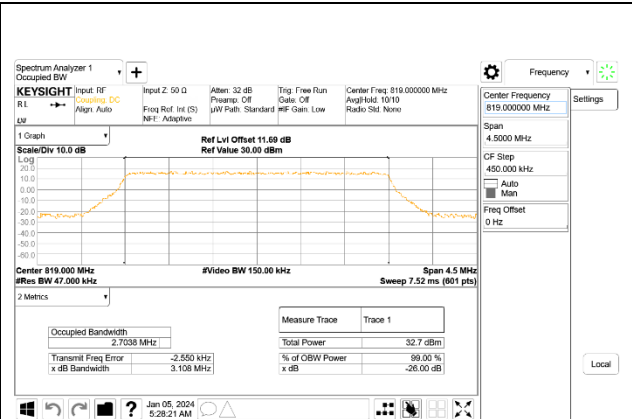

LTE B26 3MHz QPSK Middle Channel RB15-0, ID:27979

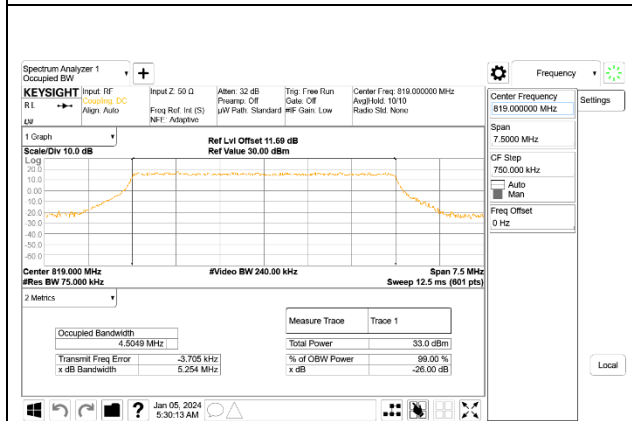

LTE B26 5MHz QPSK Middle Channel RB25-0, ID:27979

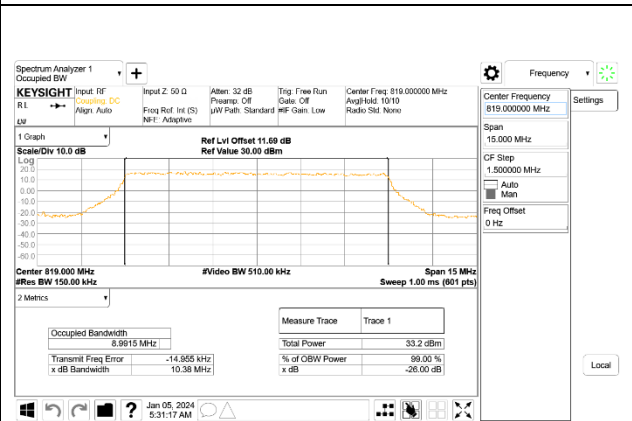

LTE B26 10MHz QPSK Middle Channel RB50-0, ID:27979

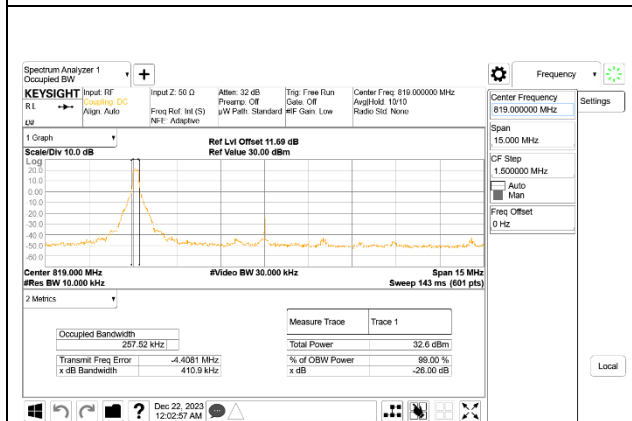

LTE B26 10MHz QPSK Middle Channel RB1-0, ID:27979

Intentionally Blank

5G NR n26 (PART 90S)

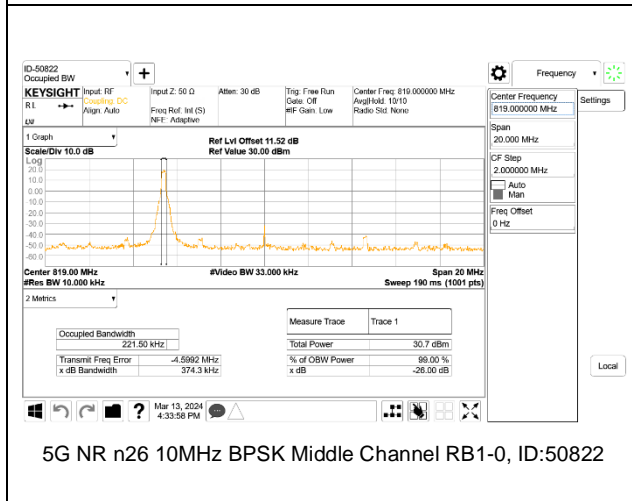
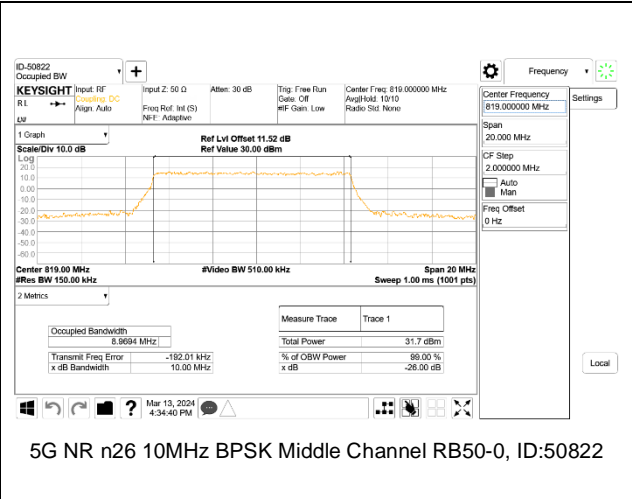
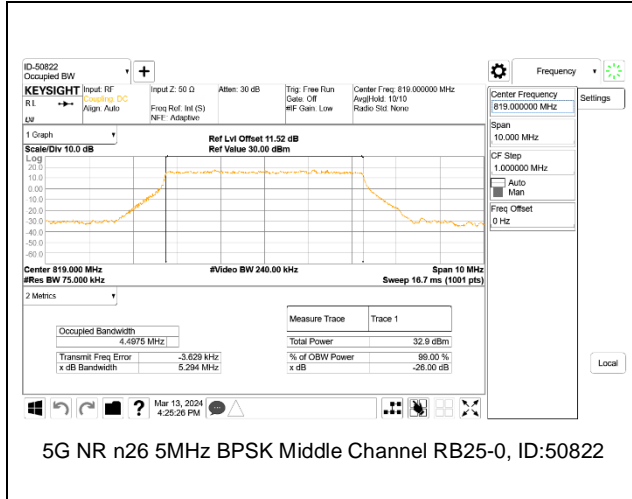

Intentionally Blank

9.1.9. LTE BAND 26 AND 5G NR n26 (PART 22)

LTE BAND 26

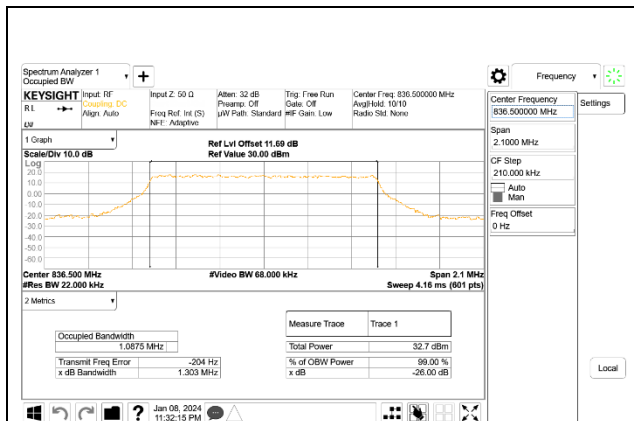

LTE B26 1.4MHz QPSK Middle Channel RB6-0, ID:27979

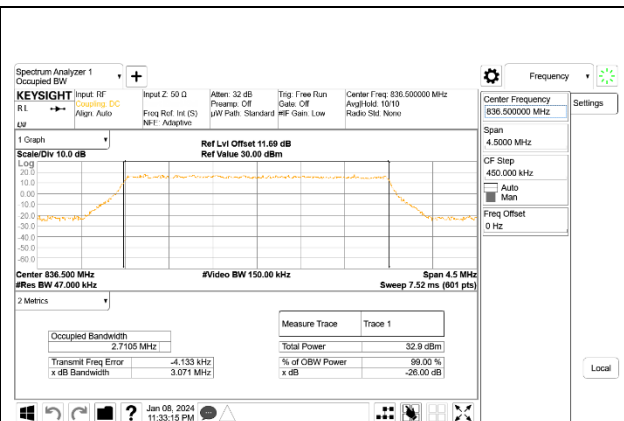

LTE B26 3MHz QPSK Middle Channel RB15-0, ID:27979

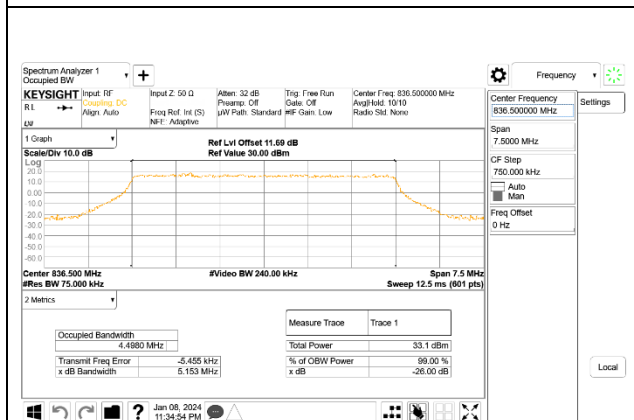

LTE B26 5MHz QPSK Middle Channel RB25-0, ID:27979

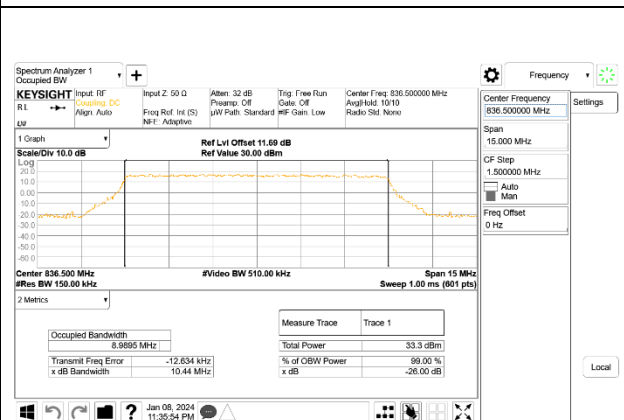

LTE B26 10MHz QPSK Middle Channel RB50-0, ID:27979

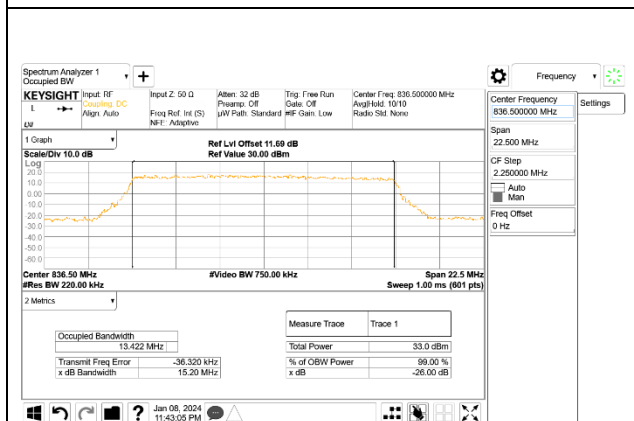

LTE B26 15MHz QPSK Middle Channel RB75-0, ID:27979

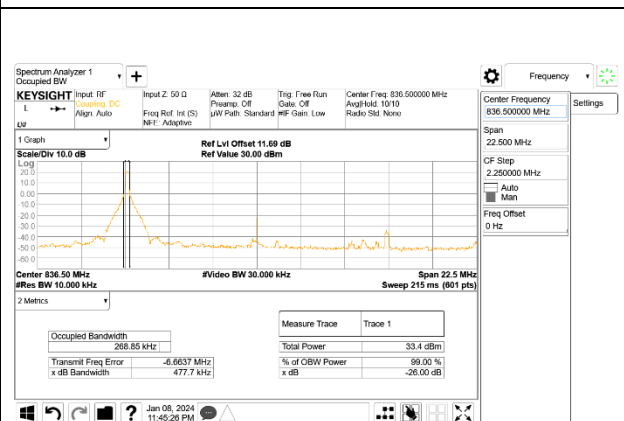

LTE B26 15MHz QPSK Middle Channel RB1-0, ID:27979

5G NR n26 (PART 22)

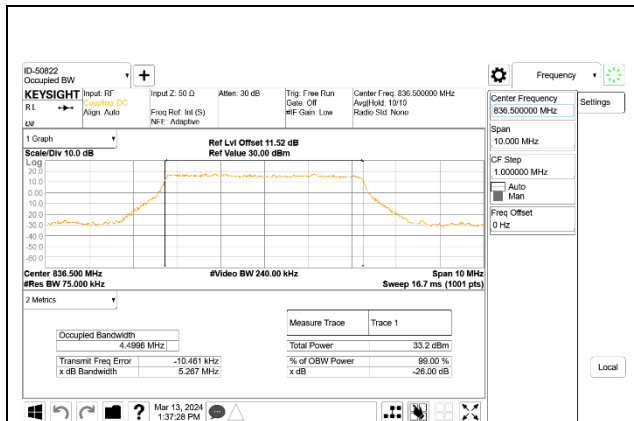

5G NR n26 5MHz BPSK Middle Channel RB25-0, ID:50822

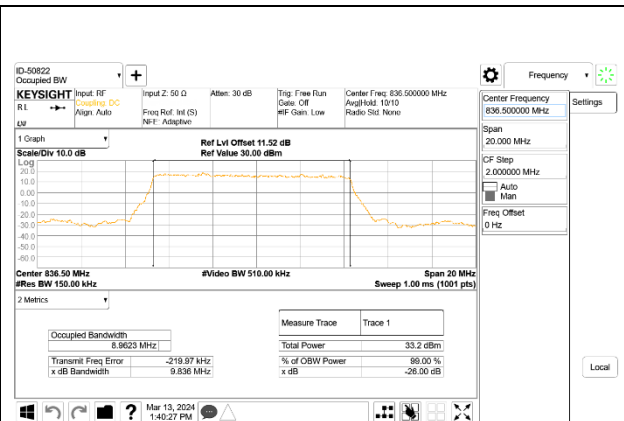

5G NR n26 10MHz BPSK Middle Channel RB50-0, ID:50822

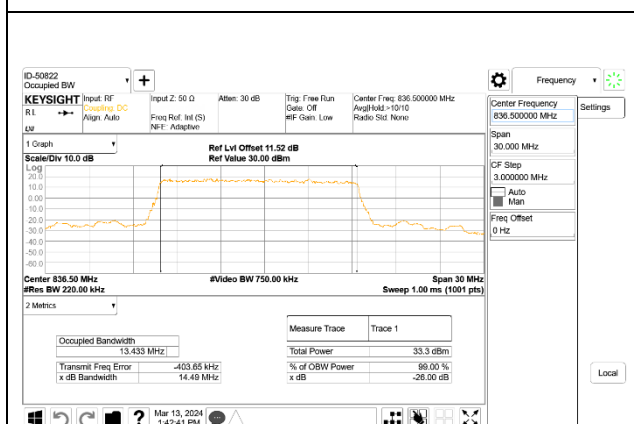

5G NR n26 15MHz BPSK Middle Channel RB75-0, ID:50822

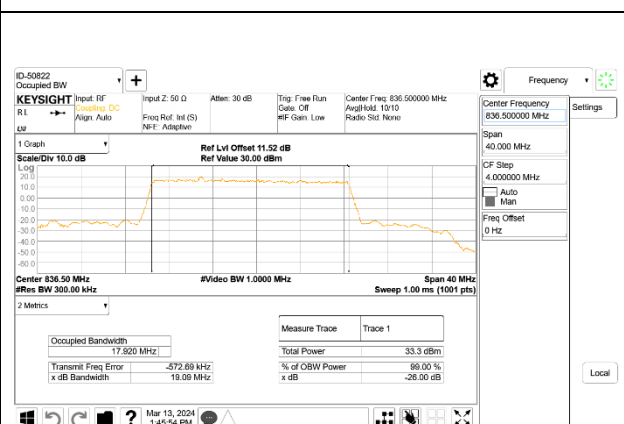

5G NR n26 20MHz BPSK Middle Channel RB100-0, ID:50822

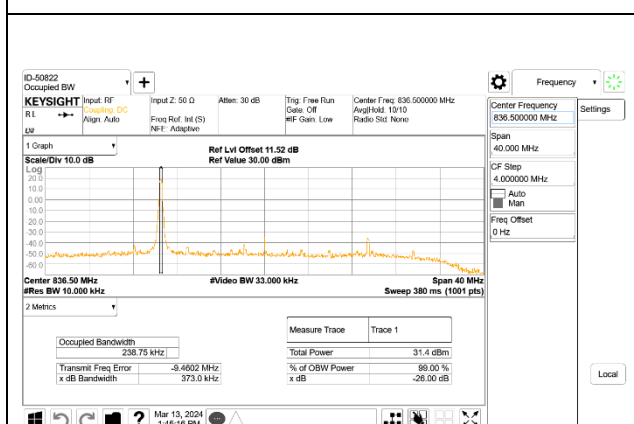

5G NR n26 20MHz Middle High Channel RB1-0, ID:50822

Intentionally Blank

9.1.10. LTE BAND 30 AND 5G NR n30

LTE BAND 30

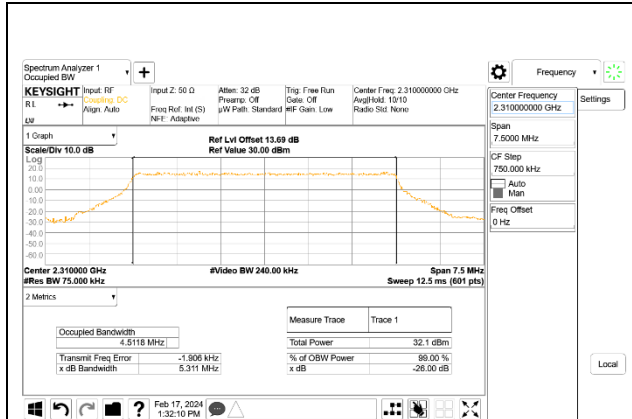

LTE B30 5MHz QPSK Middle Channel RB25-0, ID:39005

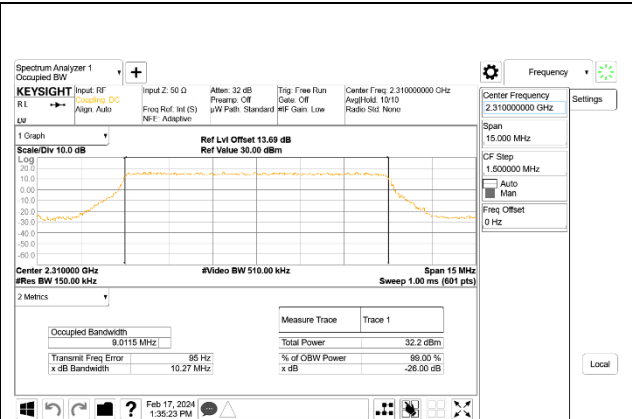

LTE B30 10MHz QPSK Middle Channel RB50-0, ID:39005

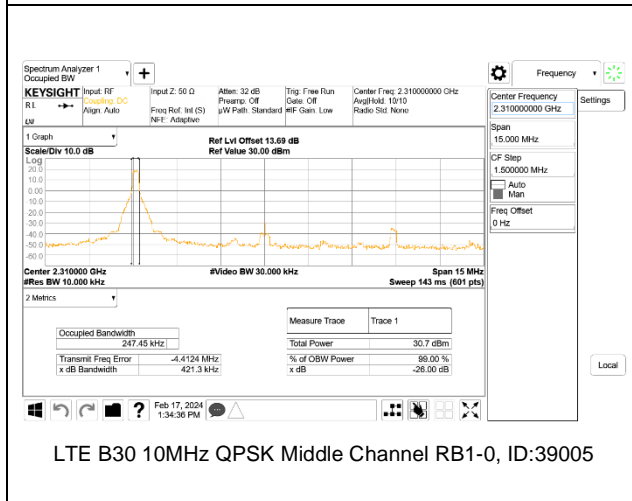

LTE B30 10MHz QPSK Middle Channel RB1-0, ID:39005

Intentionally Blank

5G NR n30

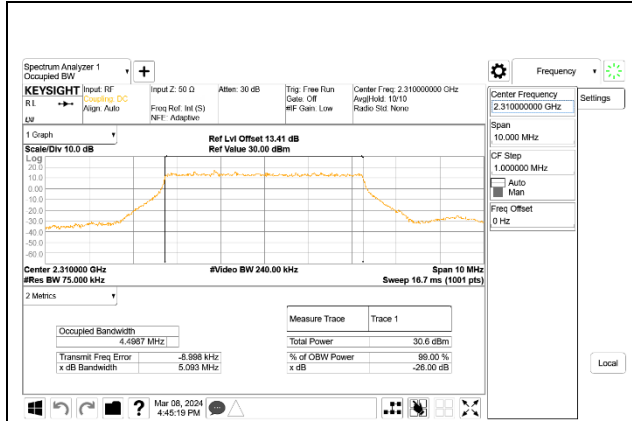

5G NR n30 5MHz BPSK Middle Channel RB25-0, ID:50822

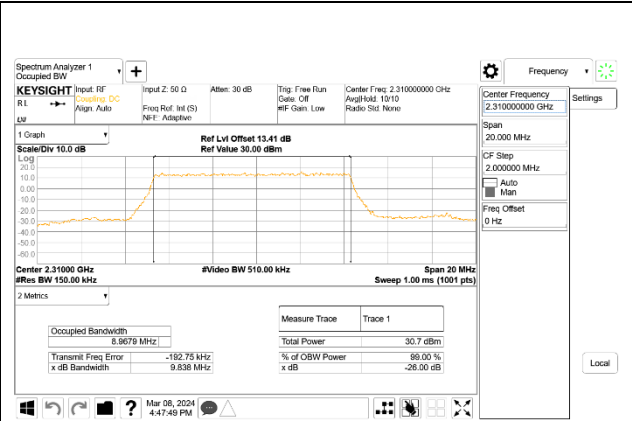

5G NR n30 10MHz BPSK Middle Channel RB50-0, ID:50822

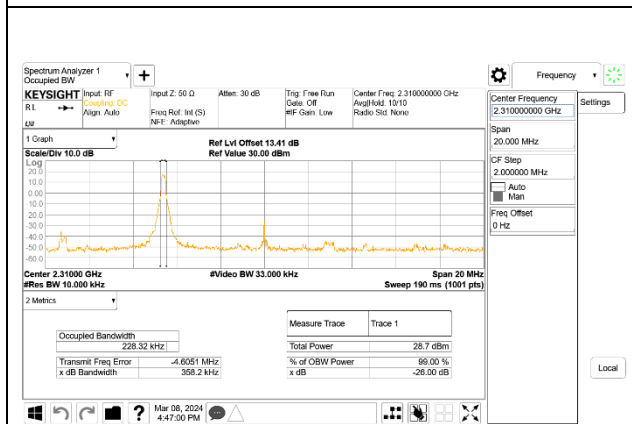

5G NR n30 10MHz BPSK Middle Channel RB1-0, ID:50822

Intentionally Blank

9.1.11. LTE BAND 41 AND 5G NR n41 HPUE

LTE BAND 41

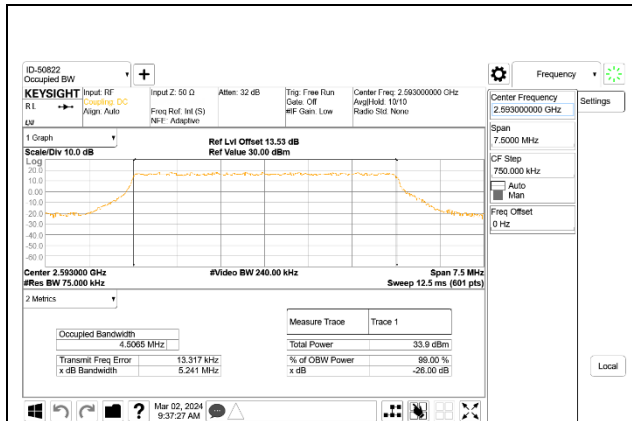

LTE B41 5MHz QPSK Middle Channel RB25-0, ID:50822

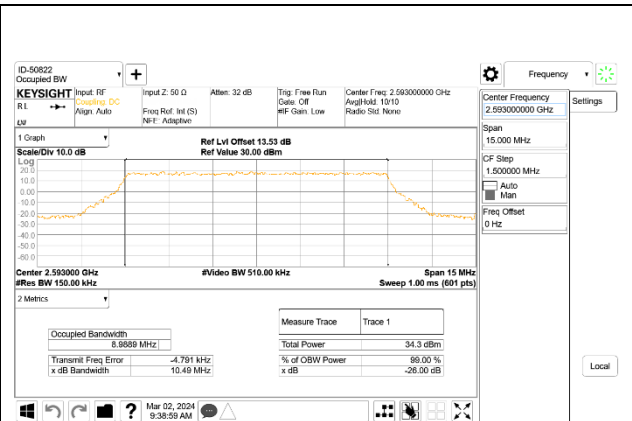

LTE B41 10MHz QPSK Middle Channel RB50-0, ID:50822

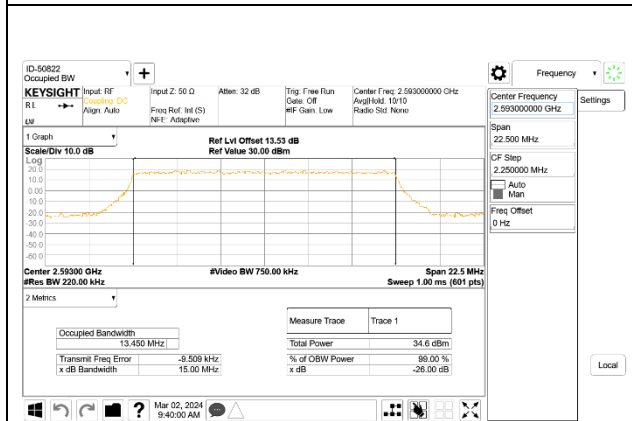

LTE B41 15MHz QPSK Middle Channel RB75-0, ID:50822

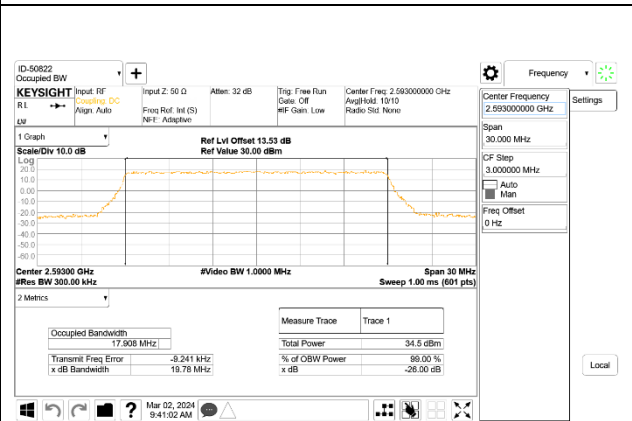

LTE B41 20MHz QPSK Middle Channel RB100-0, ID:50822

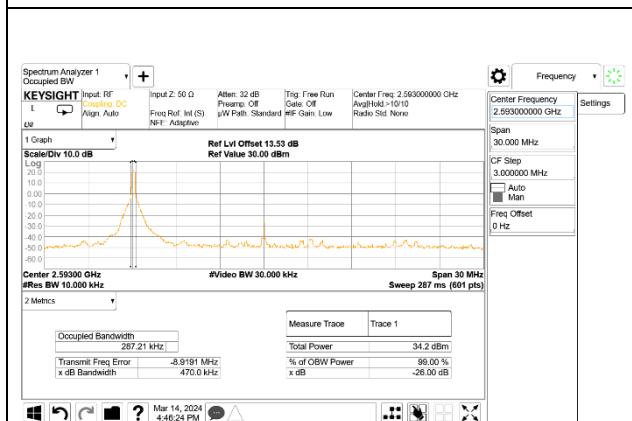

LTE B41 20MHz QPSK Middle Channel RB1-0, ID:39005

Intentionally Blank

5G NR n41

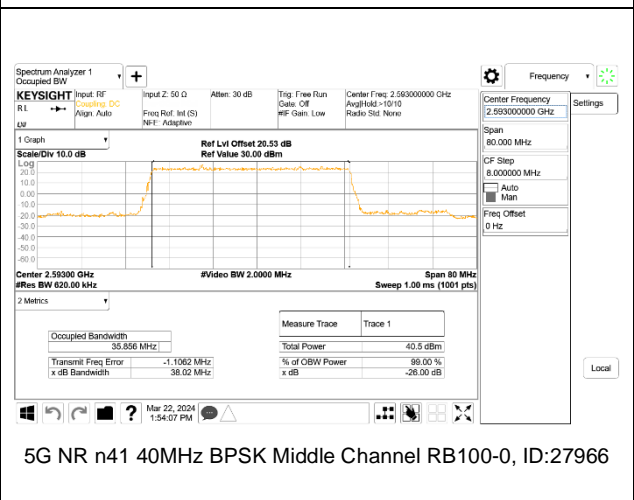
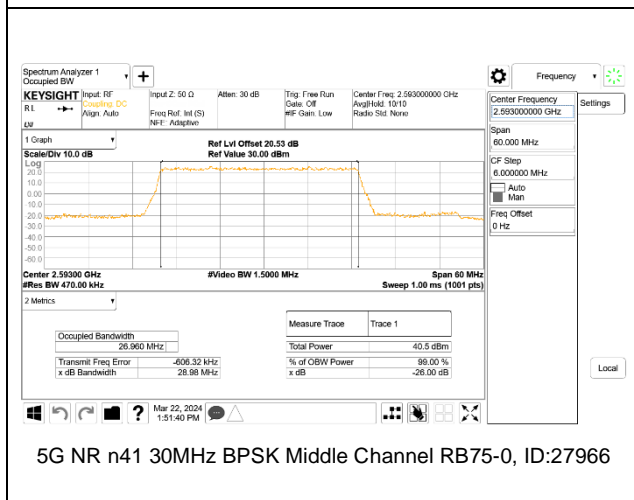
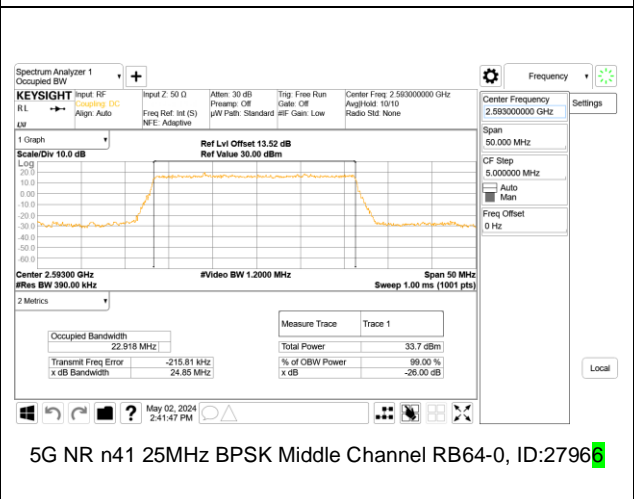
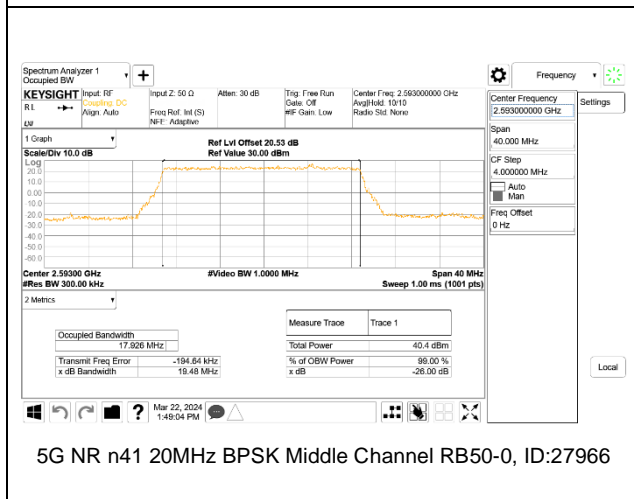
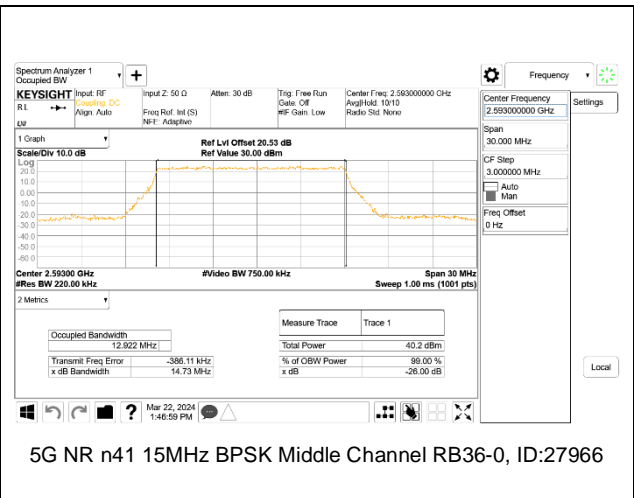
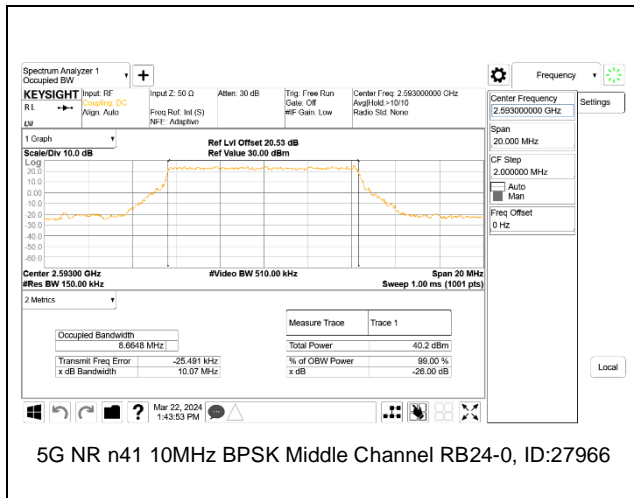

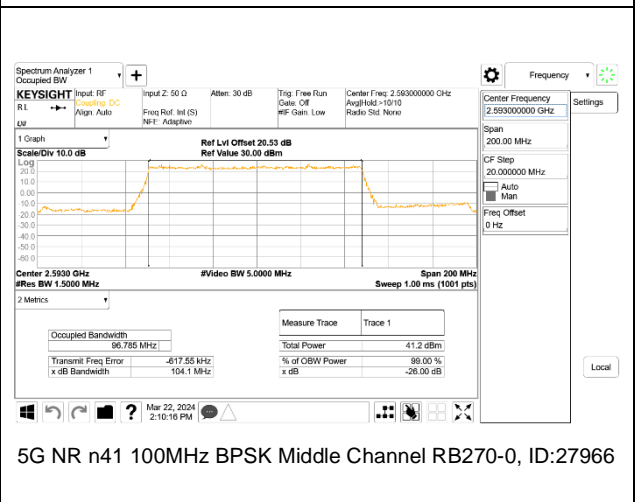
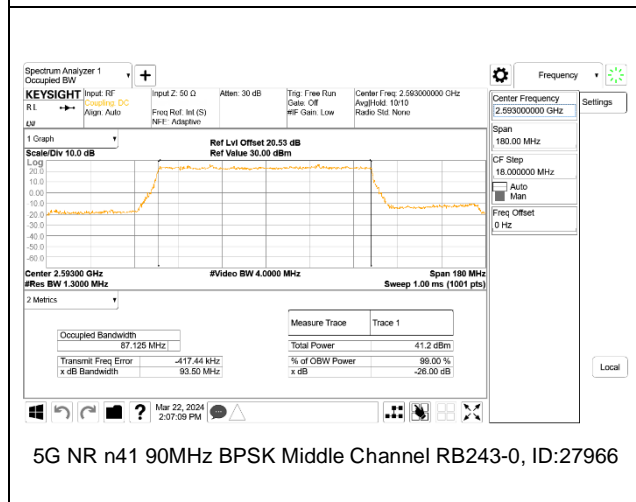
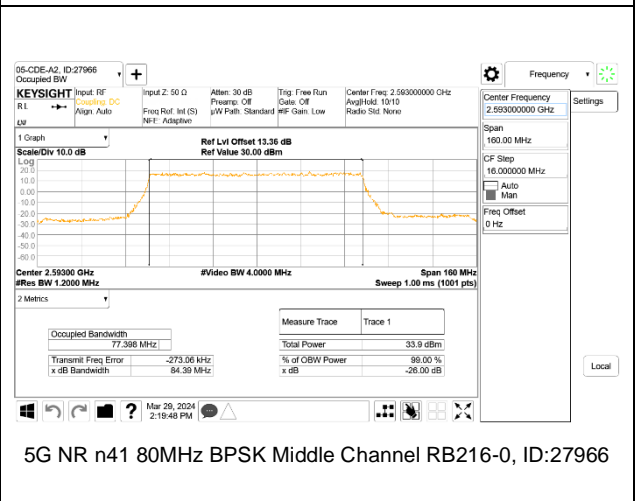
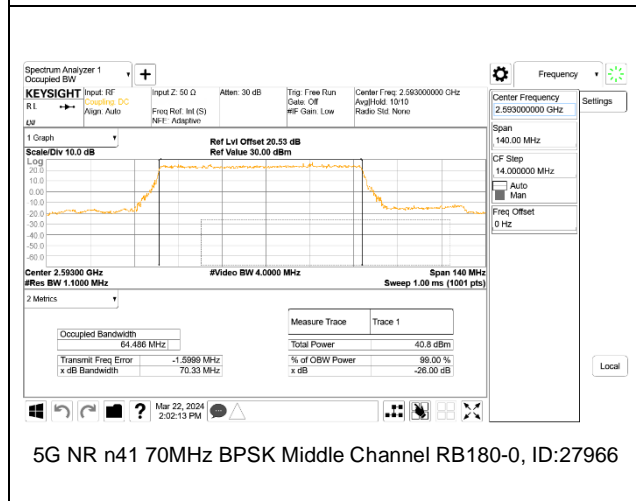
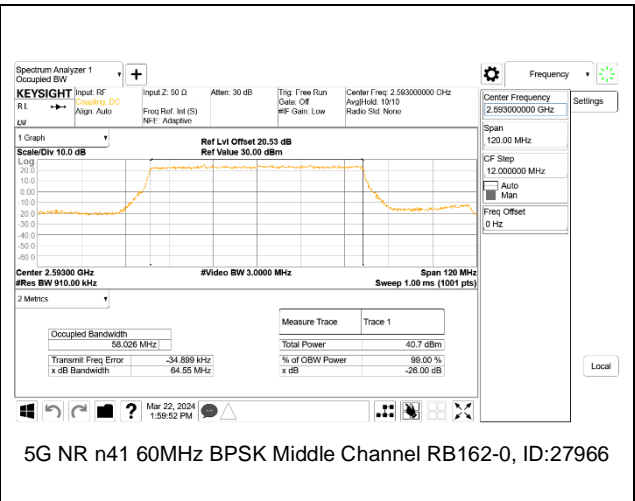
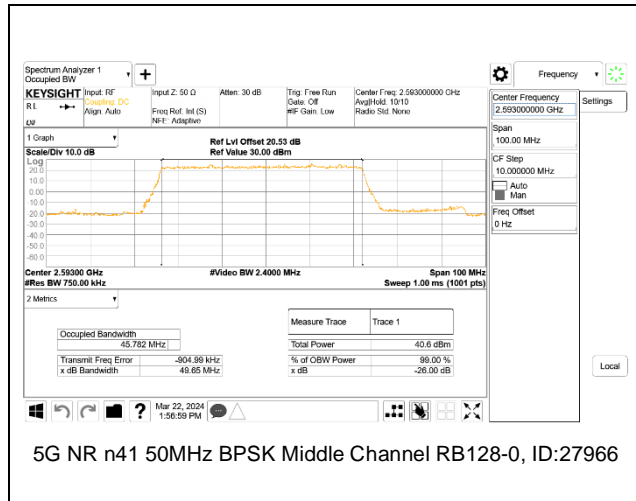

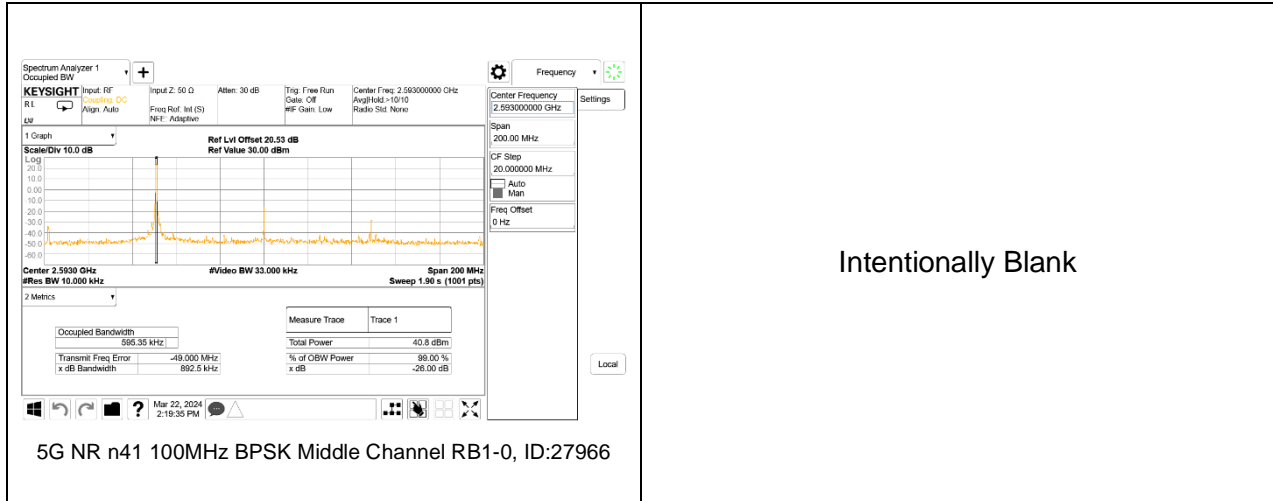

Intentionally Blank

9.1.12. LTE BAND 48 AND 5G NR n48

LTE BAND 48

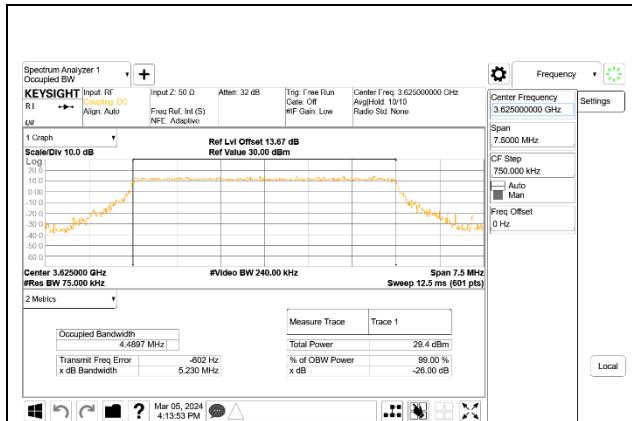

LTE B48 5MHz QPSK Middle Channel RB25-0, ID:39005

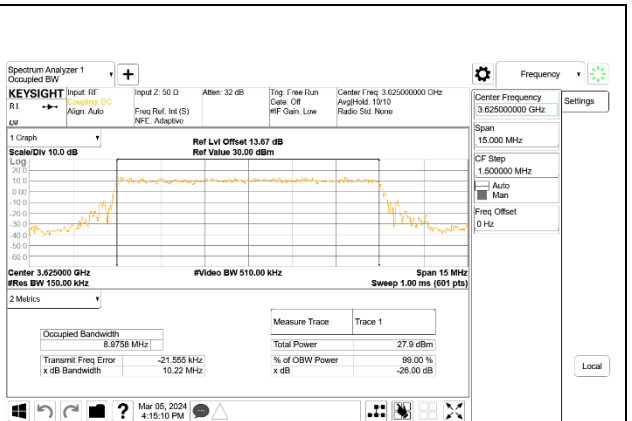

LTE B48 10MHz QPSK Middle Channel RB50-0, ID:39005

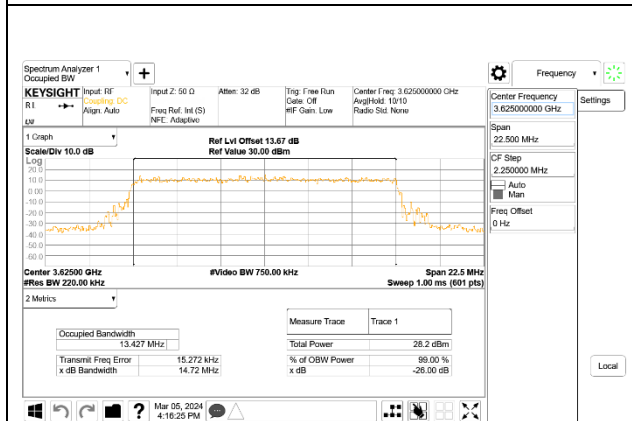

LTE B48 15MHz QPSK Middle Channel RB75-0, ID:39005

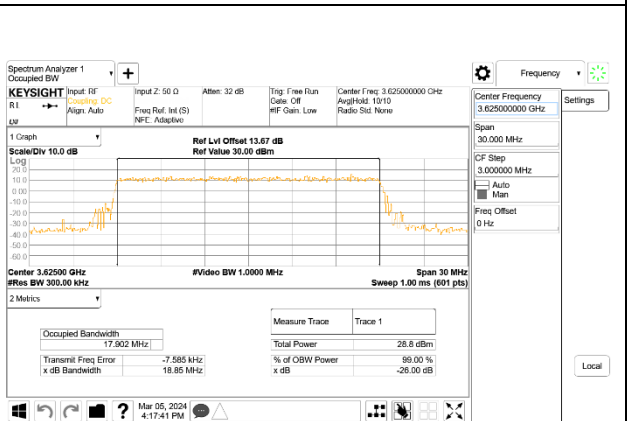

LTE B48 20MHz QPSK Middle Channel RB100-0, ID:39005

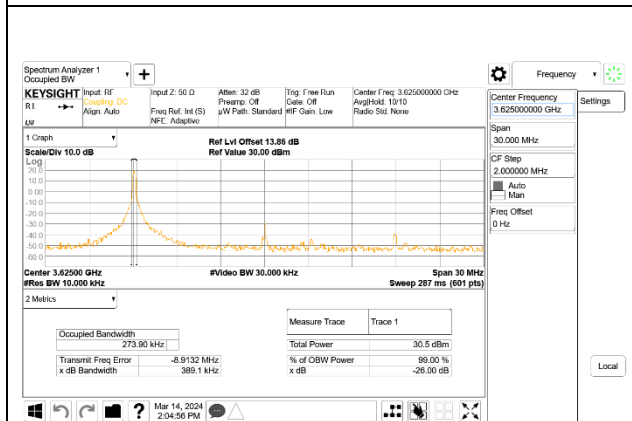

LTE B48 20MHz QPSK Middle Channel RB1-0, ID:39005

Intentionally Blank

5G NR n48

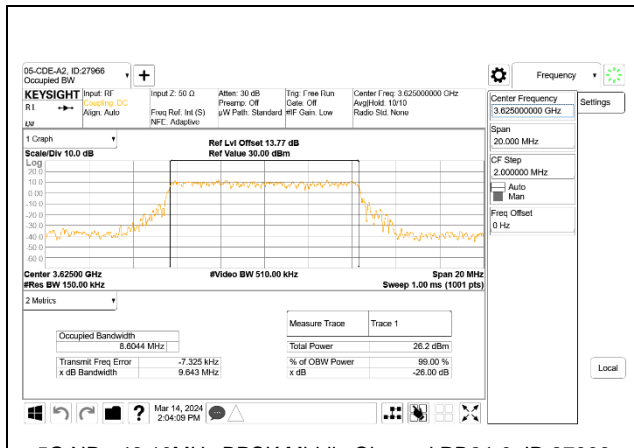

5G NR n48 10MHz BPSK Middle Channel RB24-0, ID:27966

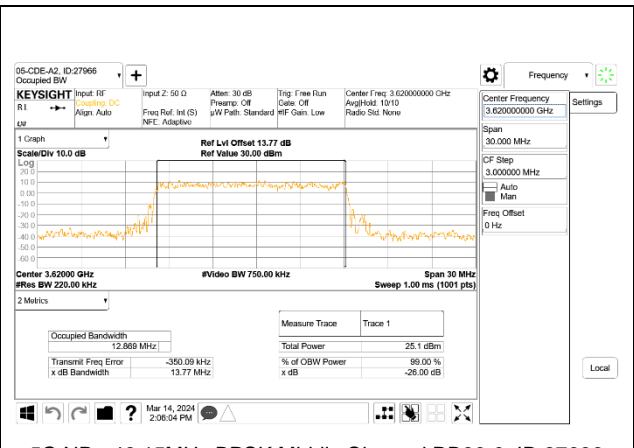

5G NR n48 15MHz BPSK Middle Channel RB36-0, ID:27966

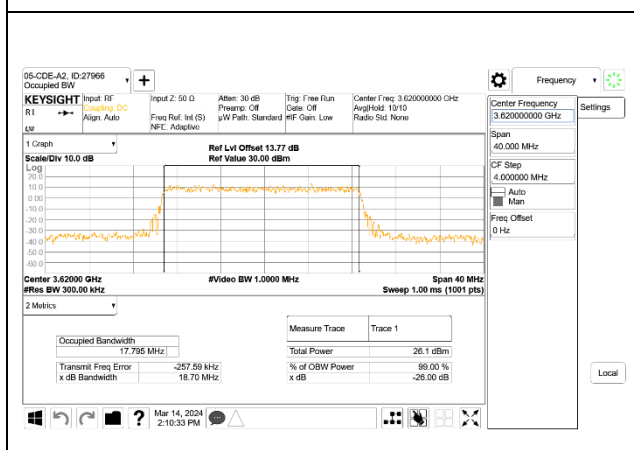

5G NR n48 20MHz BPSK Middle Channel RB50-0, ID:27966

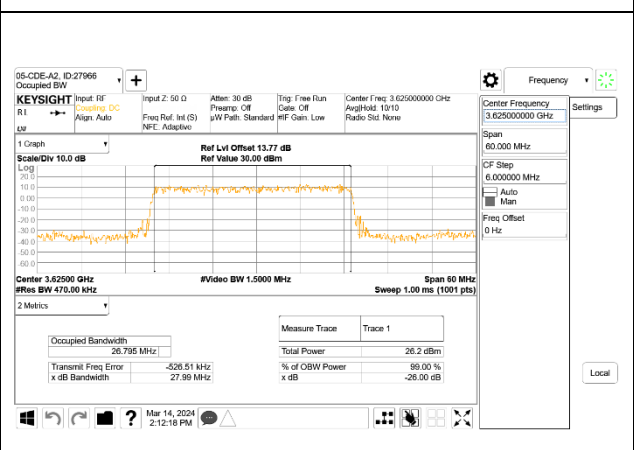

5G NR n48 30MHz BPSK Middle Channel RB75-0, ID:27966

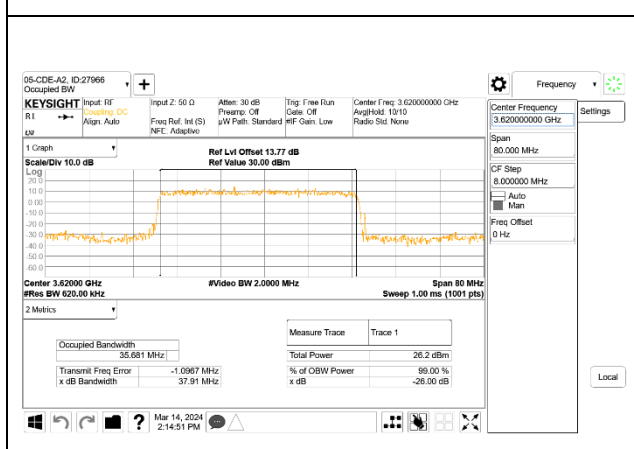

5G NR n48 40MHz BPSK Middle Channel RB100-0, ID:27966

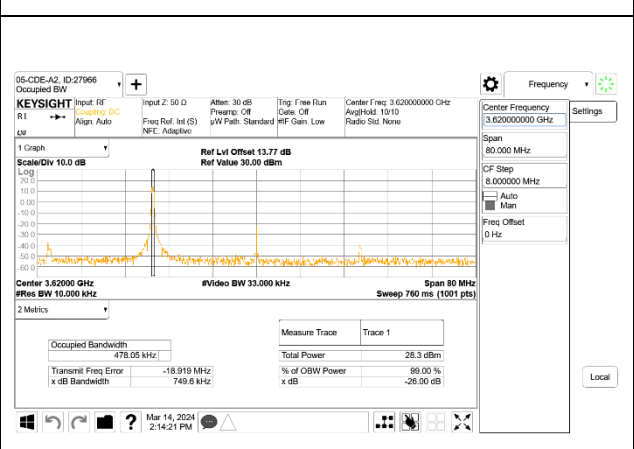

5G NR n48 40MHz BPSK Middle Channel RB1-0, ID:27966

9.1.13. LTE BAND 66 AND 5G NR n66

LTE BAND 66

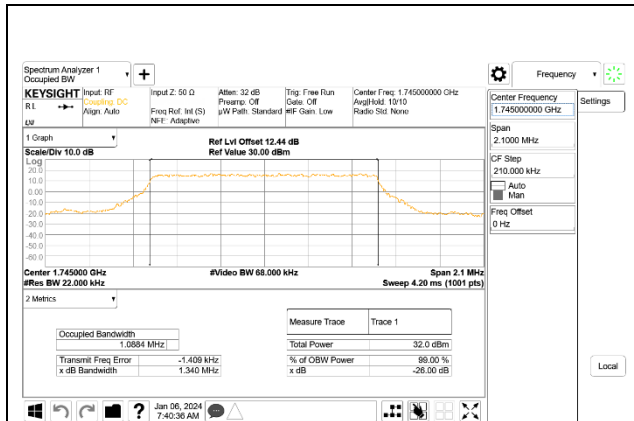

LTE B66 1.4MHz QPSK Middle Channel RB6-0, ID:39005

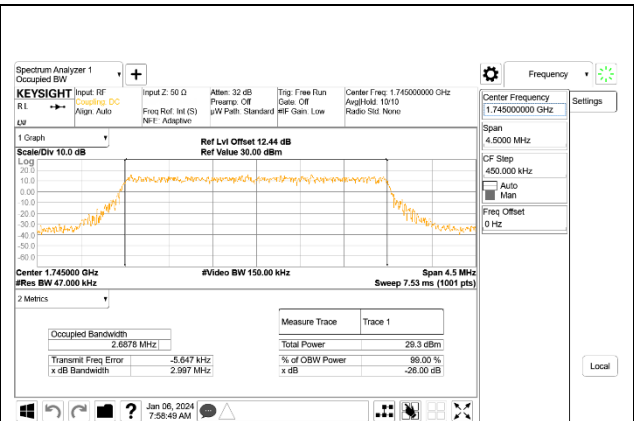

LTE B66 3MHz QPSK Middle Channel RB15-0, ID:39005

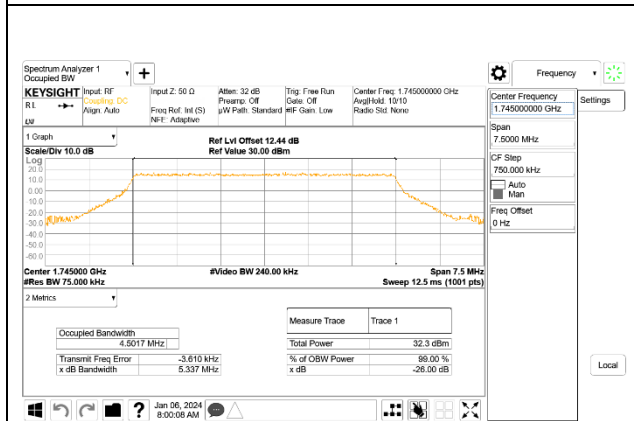

LTE B66 5MHz QPSK Middle Channel RB25-0, ID:39005

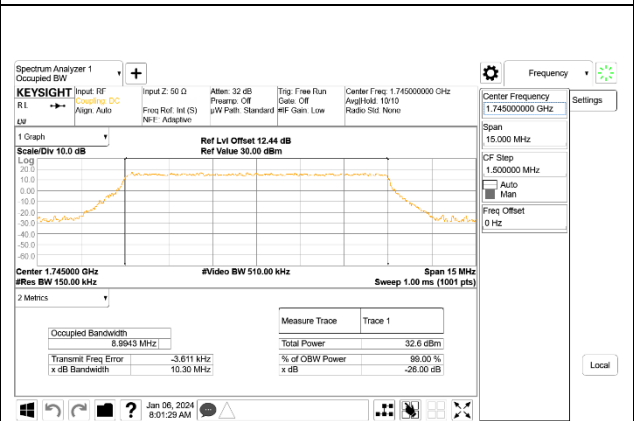

LTE B66 10MHz QPSK Middle Channel RB50-0, ID:39005

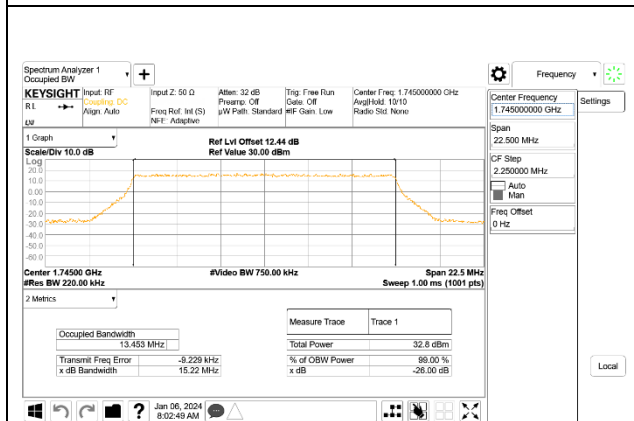

LTE B66 15MHz QPSK Middle Channel RB75-0, ID:39005

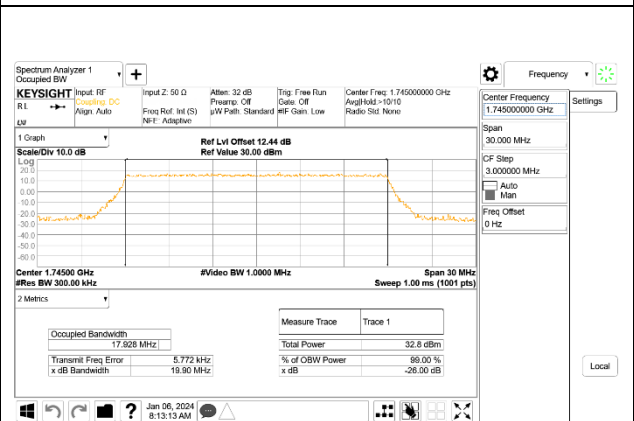

LTE B66 20MHz QPSK Middle Channel RB100-0, ID:39005

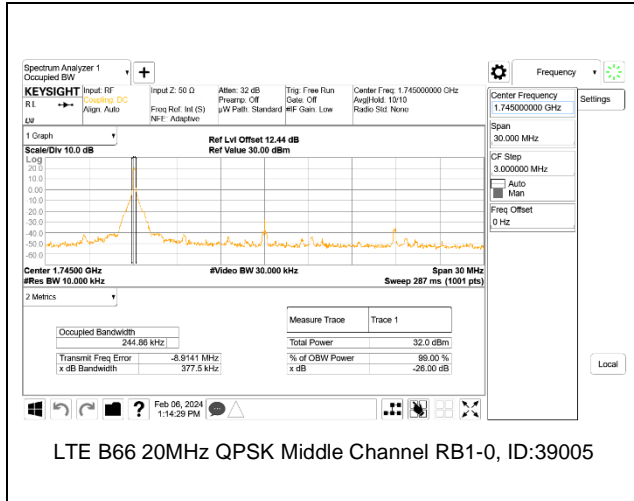

Intentionally Blank

5G NR n66

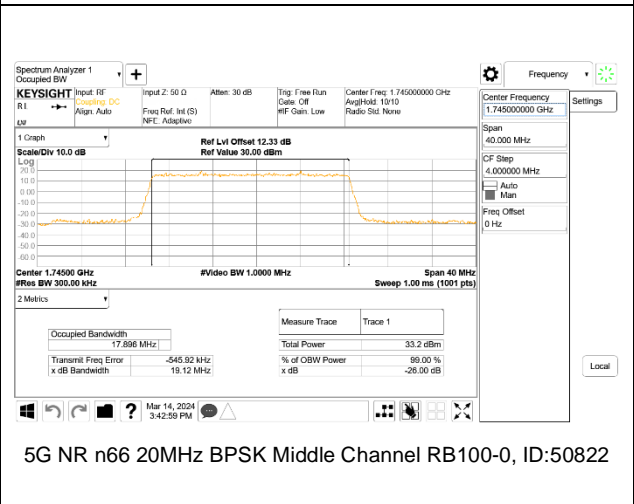
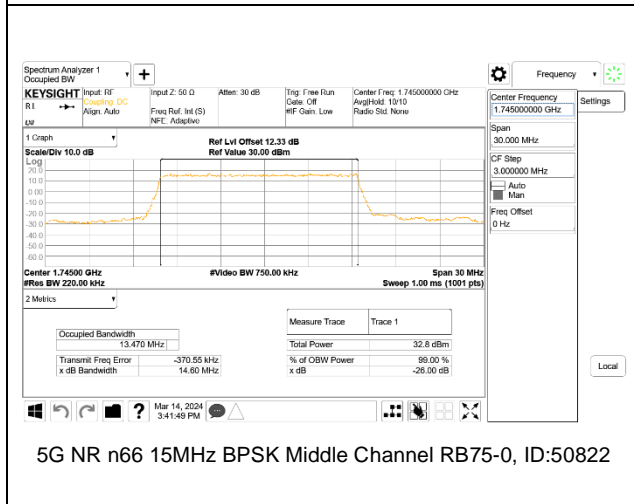
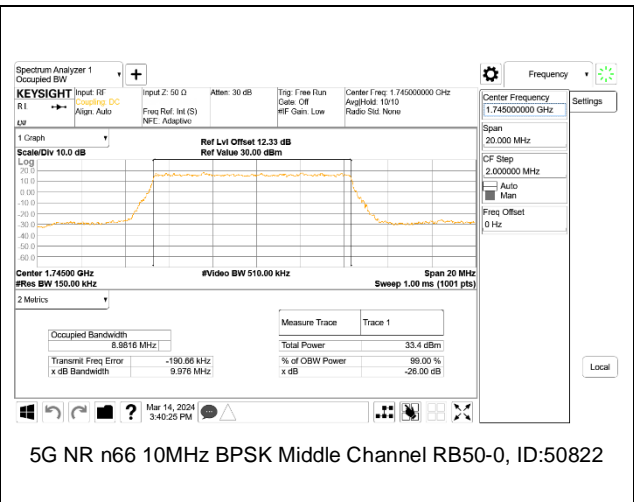
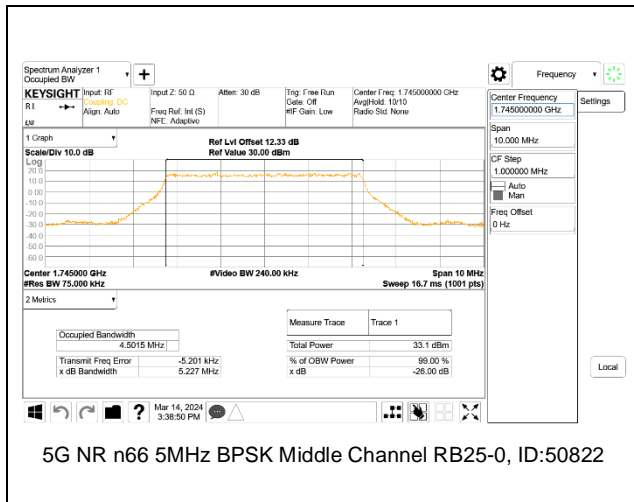

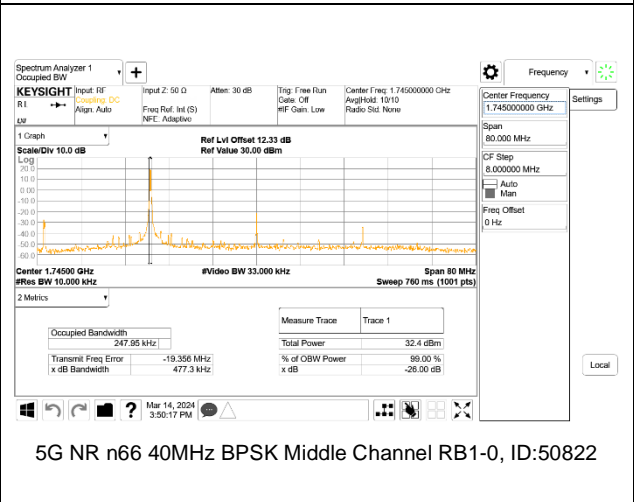
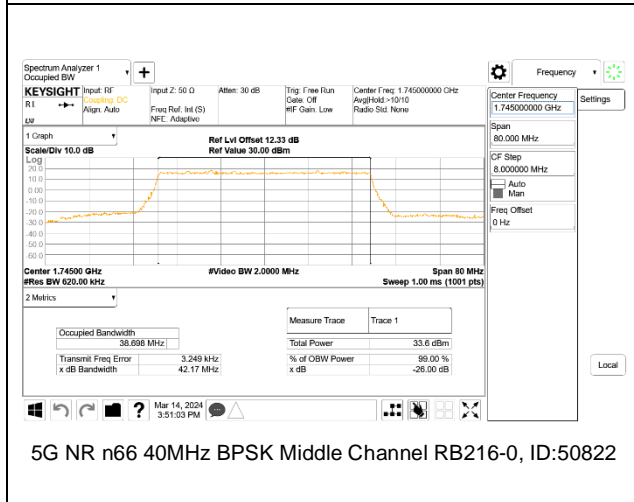
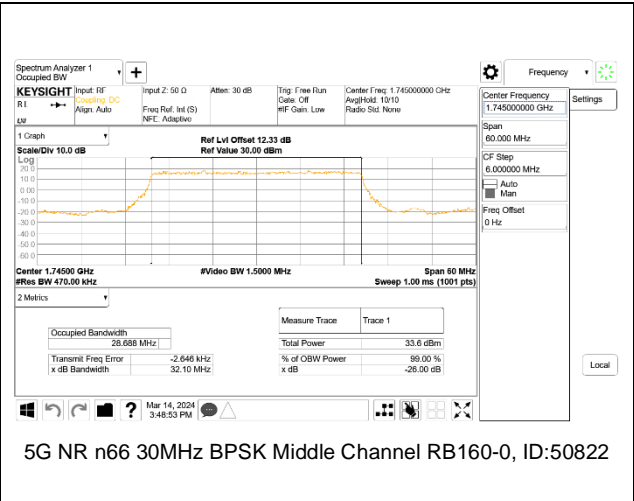
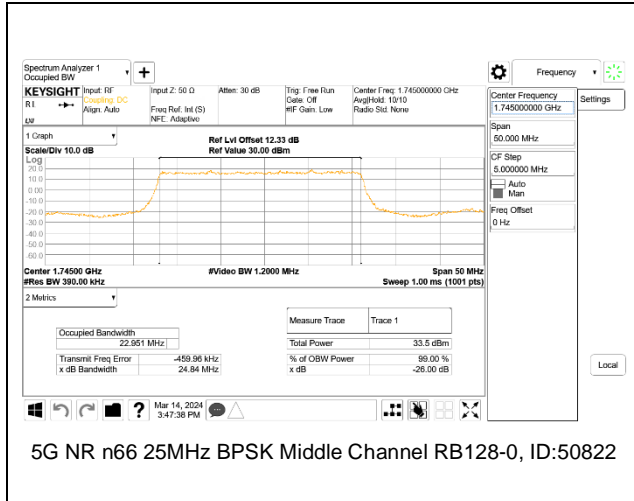

9.1.14. 5G NR n70

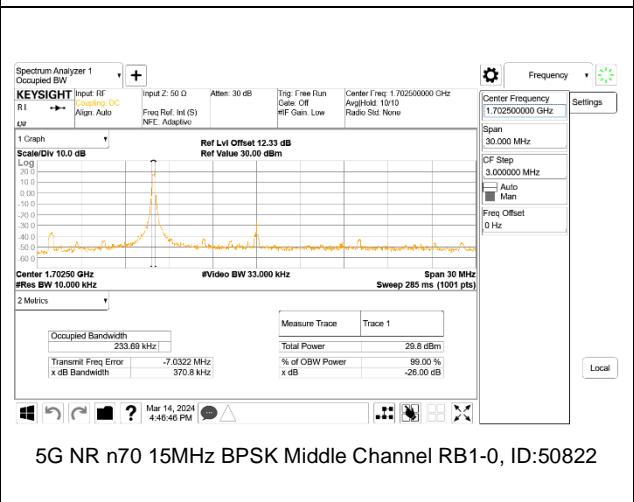
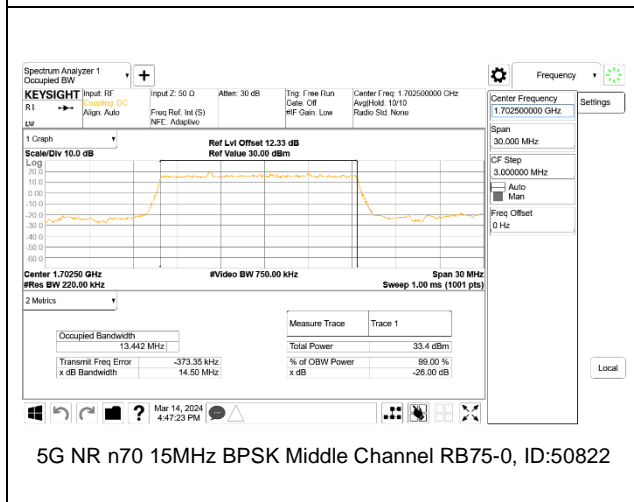
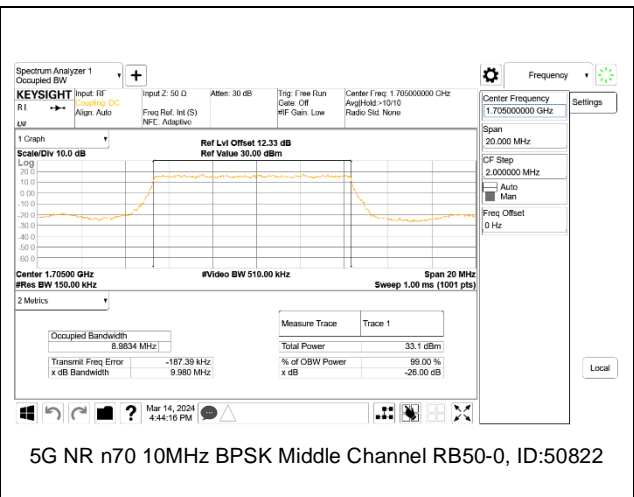
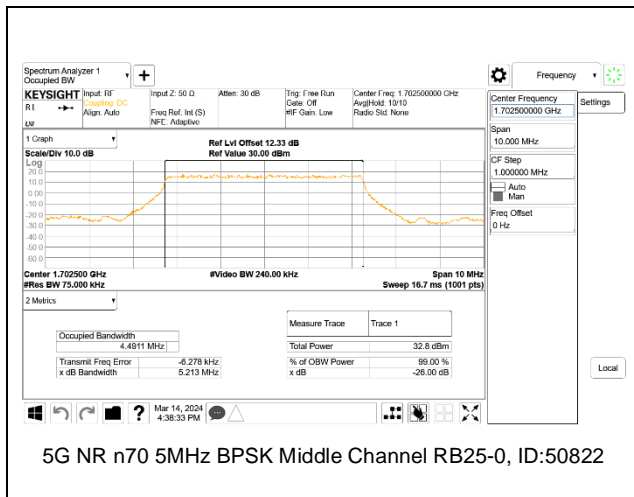

9.1.15. LTE BAND 71 AND 5G NR n71

LTE BAND 71

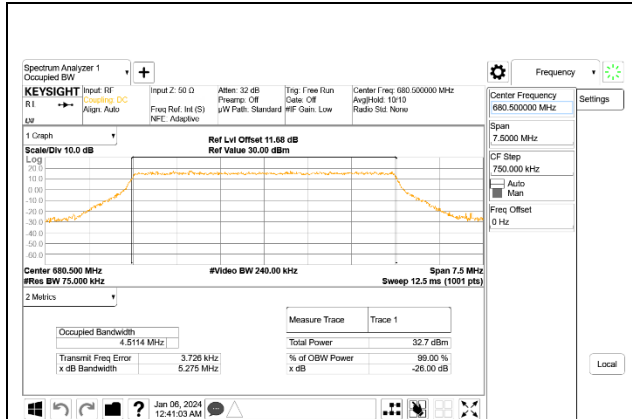

LTE B71 5MHz QPSK Middle Channel RB25-0, ID:19210

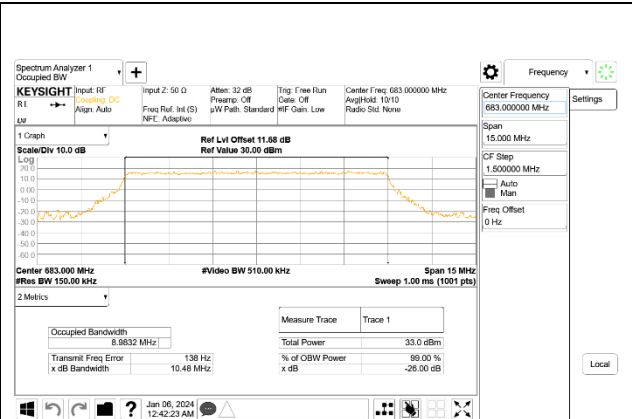

LTE B71 10MHz QPSK Middle Channel RB50-0, ID:19210

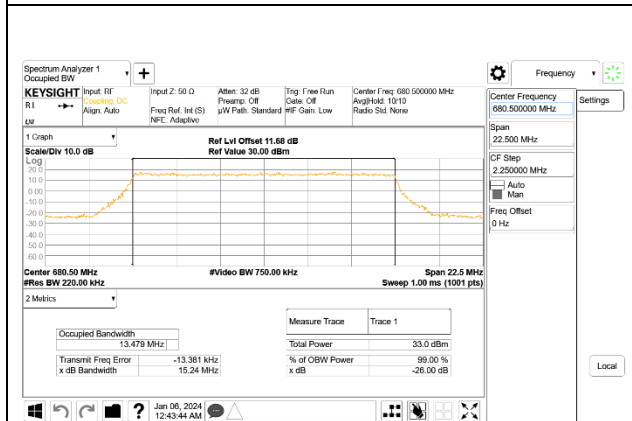

LTE B71 15MHz QPSK Middle Channel RB75-0, ID:19210

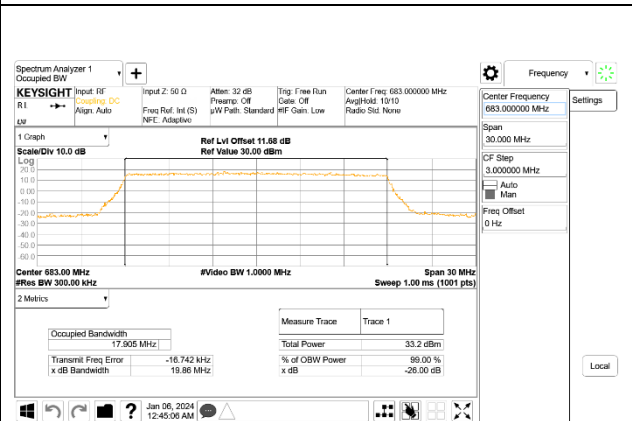

LTE B71 20MHz QPSK Middle Channel RB100-0, ID:19210

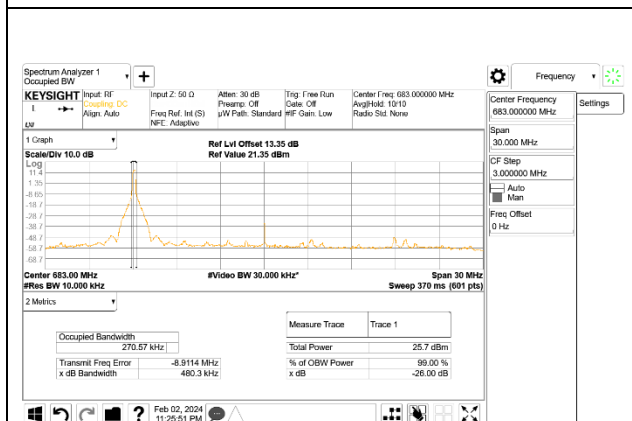

LTE B71 20MHz QPSK Middle Channel RB1-0, ID:19210

Intentionally Blank

5G NR n71

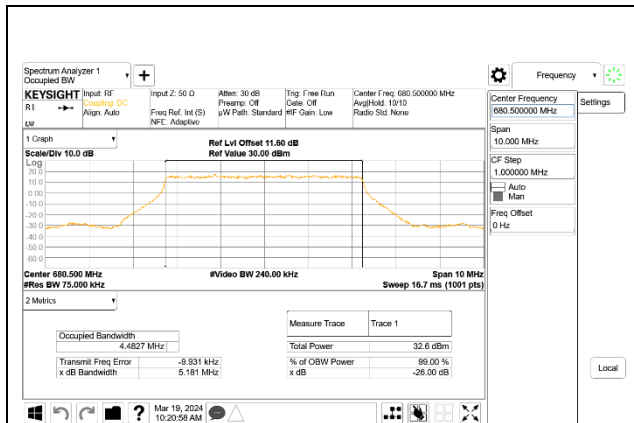

5G NR n71 5MHz BPSK Middle Channel RB25-0, ID:50822

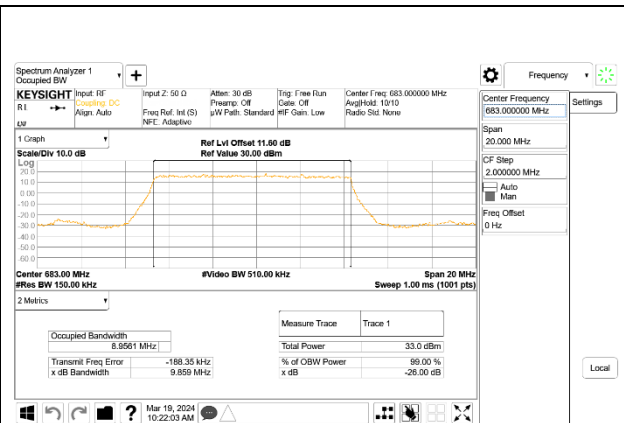

5G NR n71 10MHz BPSK Middle Channel RB50-0, ID:50822

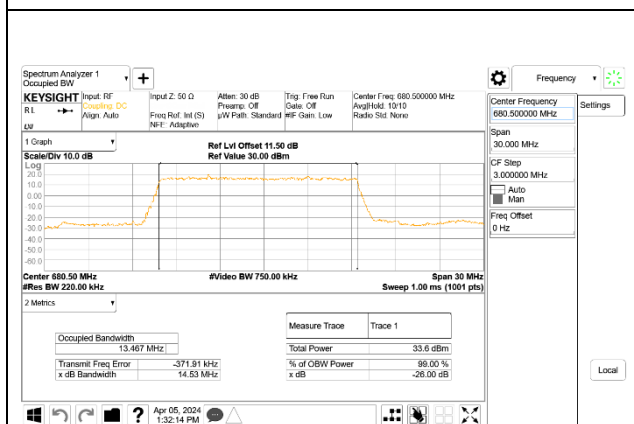

5G NR n71 15MHz BPSK Middle Channel RB75-0, ID:50822

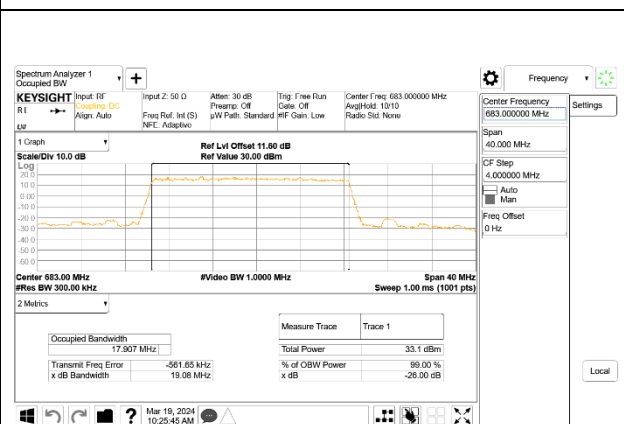

5G NR n71 20MHz BPSK Middle Channel RB100-0, ID:50822

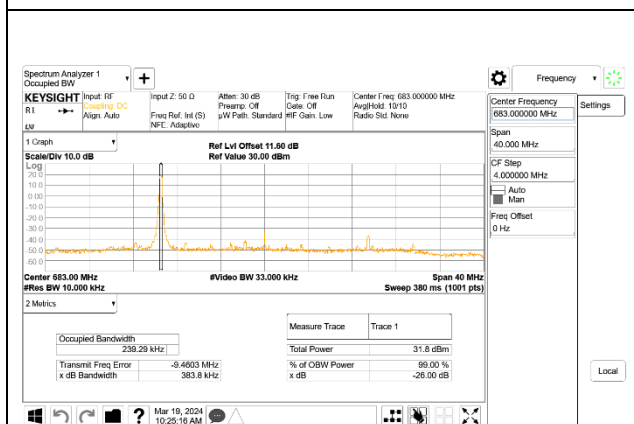

5G NR n71 20MHz BPSK Middle Channel RB1-0, ID:50822

Intentionally Blank

9.1.16. 5G NR n77 (Part 27 3450-3550MHz) HPUE

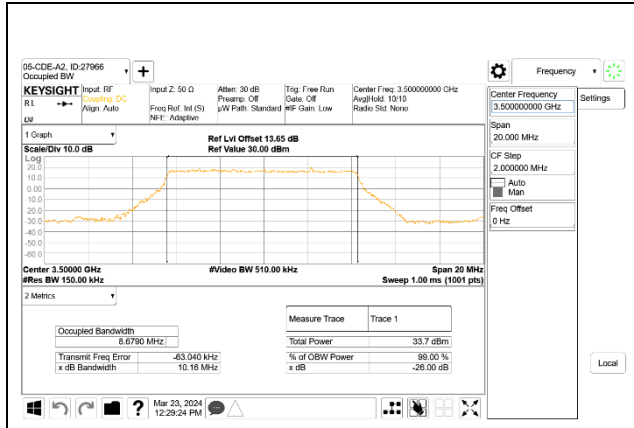

5G NR n77 10MHz BPSK Middle Channel RB24-0, ID:27966

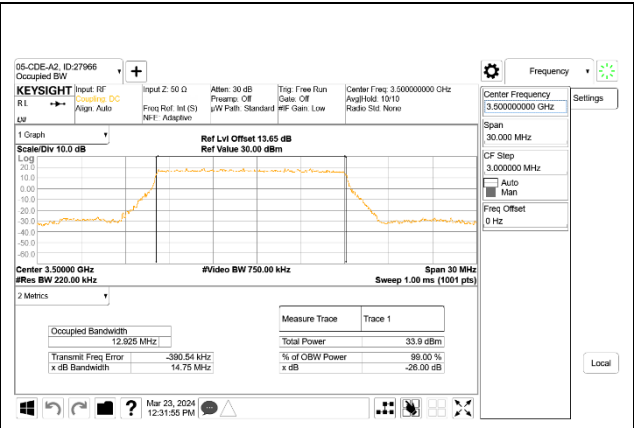

5G NR n77 15MHz BPSK Middle Channel RB36-0, ID:27966

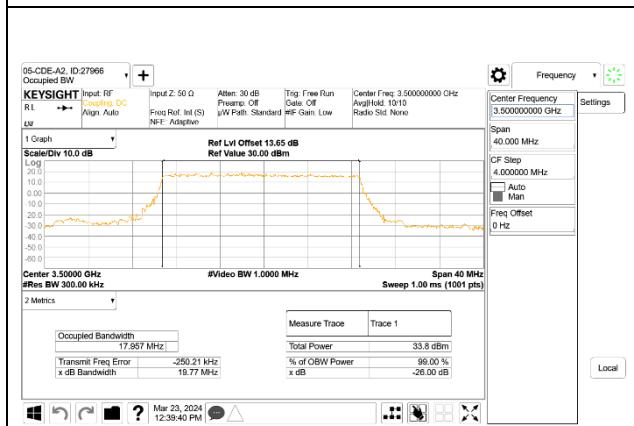

5G NR n77 20MHz BPSK Middle Channel RB50-0, ID:27966

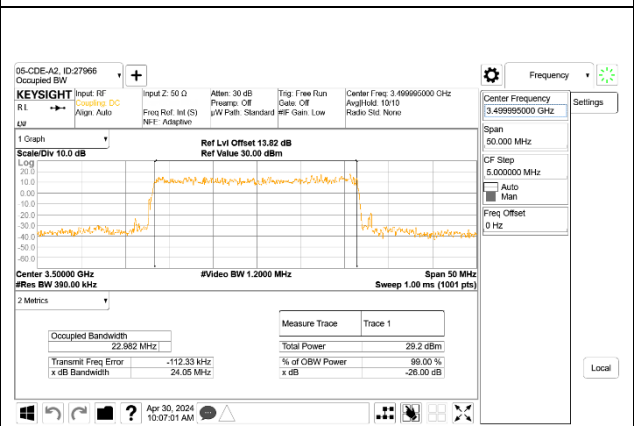

5G NR n77 25MHz BPSK Middle Channel RB64-0, ID:27966

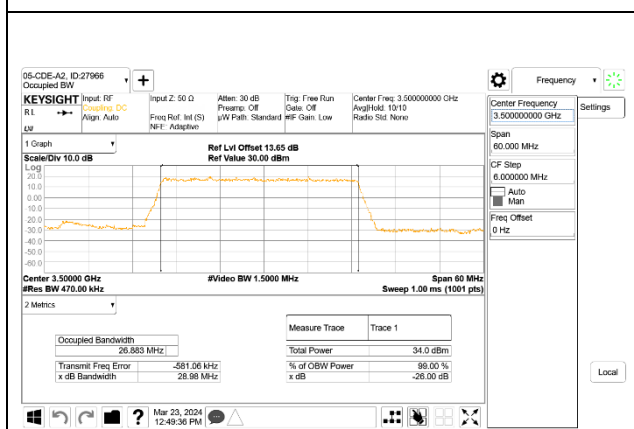

5G NR n77 30MHz BPSK Middle Channel RB75-0, ID:27966

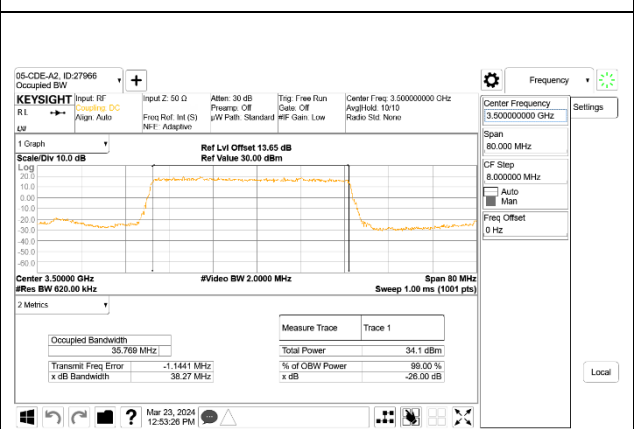

5G NR n77 40MHz BPSK Middle Channel RB100-0, ID:27966

