



FCC Part 96.47 TEST REPORT

FCC ID : A4RGR83Y
Equipment : Phone
Model Name : GR83Y
Applicant : Google LLC
1600 Amphitheatre Parkway,
Mountain View, California, 94043 USA
Standard : FCC Part 96.47
RF Interface : NR n48

The product was received on Nov. 30, 2023, and testing was performed from Jan. 16, 2024 to Jan. 16, 2024. We, Sporton International Inc. Wensan Laboratory, would like to declare that the tested sample has been evaluated in accordance with the test procedures and has been in compliance with the applicable technical standards.

The test results in this report apply exclusively to the tested model / sample. Without written approval of Sporton International Inc. Wensan Laboratory, the test report shall not be reproduced except in full.

Approved by: Jones Tsai

Sporton International Inc. Wensan Laboratory

No.58, Aly. 75, Ln. 564, Wenhua 3rd, Rd., Guishan Dist., Taoyuan City 333010, Taiwan (R.O.C)



Table of Contents

History of this test report.....3

Summary of Test Result.....4

1 General Description5

 1.1 Product Feature of Equipment Under Test.....5

 1.2 Modification of EUT5

 1.3 Testing Laboratory.....5

 1.4 Applicable Standards.....6

2 Test Configuration of Equipment Under Test7

 2.1 Connection Diagram of Test System.....7

3 End User Device additional requirement8

 3.1 Test Requirement8

 3.2 Test Procedure8

 3.3 Test Result.....9

4 List of Measuring Equipment.....11

Appendix A. Setup Photographs



Summary of Test Result

Report Clause	Ref Std. Clause	Test Items	Result (PASS/FAIL)	Remark
3	96.47	End User Device additional requirement	Pass	-

Conformity Assessment Condition:

The test results (PASS/FAIL) with all measurement uncertainty excluded are presented against the regulation limits or in accordance with the requirements stipulated by the applicant/manufacturer who shall bear all the risks of non-compliance that may potentially occur if measurement uncertainty is taken into account.

Disclaimer:

The product specifications of the EUT presented in the test report that may affect the test assessments are declared by the manufacturer who shall take full responsibility for the authenticity.

Reviewed by: William Chen

Report Producer: Michelle Chen



1 General Description

1.1 Product Feature of Equipment Under Test

Product Feature
<p>General Specs GSM/WCDMA/LTE/5G NR, Bluetooth, BLE, BLE channel sounding, Thread, Wi-Fi 802.11be, UWB, NFC, WPT, NTN and GNSS.</p> <p>Antenna Type WWAN: <Ant. 0>: PIFA Antenna <Ant. 1>: PIFA Antenna <Ant. 2>: IFA Antenna <Ant. 5>: PIFA Antenna <Ant. 6>: PIFA Antenna <Ant. 7>: PIFA Antenna</p>

Remark: The above EUT's information was declared by manufacturer. Please refer to Disclaimer in report summary.

EUT Information List	
S/N	Performed Test Item
3B181FDAP00052	Conducted Measurement

1.2 Modification of EUT

No modifications are made to the EUT during the entire test sessions.

1.3 Testing Laboratory

Test Site	Sporton International Inc. Wensan Laboratory
Test Site Location	No.58, Aly. 75, Ln. 564, Wenhua 3rd, Rd., Guishan Dist., Taoyuan City 333010, Taiwan (R.O.C.) TEL: +886-3-327-0868 FAX: +886-3-327-0855
Test Site No.	Sporton Site No. TH05-HY
Test Engineer	Alston Tsai
Temperature	21 ~ 23 °C
Relative Humidity	47 ~ 52 %

FCC designation No.: TW3786



1.4 Applicable Standards

- ♦ FCC Part 96.47
- ♦ FCC KDB 940660 D01 Part 96 CBRS Eqpt v03
- ♦ WINNF-TS-0122-V1.0.2 CBRS CBSD Test Specification

Remark:

1. All test items were verified and recorded according to the standards and without any deviation during the test.
2. The TAF code is not including all the FCC KDB listed without accreditation.

2 Test Configuration of Equipment Under Test

2.1 Connection Diagram of Test System

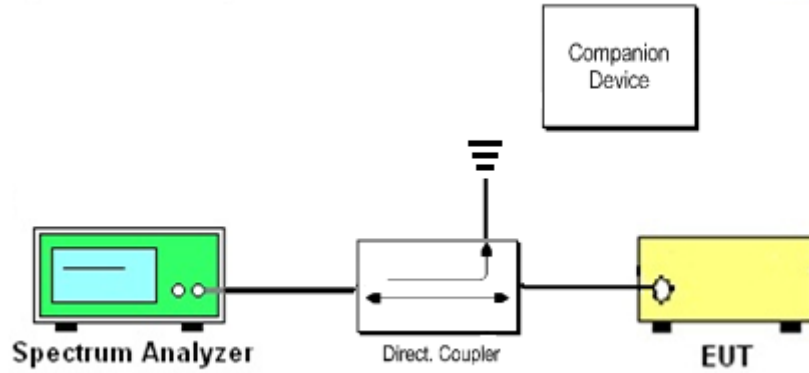

The companion device is a certified NR CBSD (FCC ID: PIDAS2900)



3 End User Device additional requirement

3.1 Test Requirement

FCC Part 96.47

(a) End User Devices may operate only if they can positively receive and decode an authorization signal transmitted by a CBSD, including the frequencies and power limits for their operation.

(1) An End User Device must discontinue operations, change frequencies, or change its operational power level within 10 seconds of receiving instructions from its associated CBSD.

3.2 Test Procedure

The following procedure is following in accordance with WINNF-TS-0122-V1.0.2 CBRS CBSD Test Specification, using the certified Airspan NR CBSD (FCC ID: PIDAS2900) as companion device to present compliance with Part 96.47 requirement for End User Device (EUD):

1. Configure SAS granted CBSD to operate at frequency 3560-3600 MHz and power level 10 dBm/MHz
2. Enable CBSD service from Airspan ACP management
3. Check EUD Tx Frequency and power
4. Disable CBSD service from Airspan ACP management
 - a. Check if EUD stops transmission within 10 seconds.

5. Configure SAS granted CBSD to operate at frequency 3650-3690 MHz and power level 20 dBm/MHz
6. Enable CBSD service from Airspan ACP management
7. Check EUD Tx Frequency and power
8. Disable CBSD service from Airspan ACP management
 - a. Check if EUD stops transmission within 10 seconds.

3.3 Test Result

[Step 1] Configure SAS granted CBSD to operate at frequency 3560-3600 MHz and power level 10 dBm/MHz

[Step 3] Check EUD Tx Frequency and power

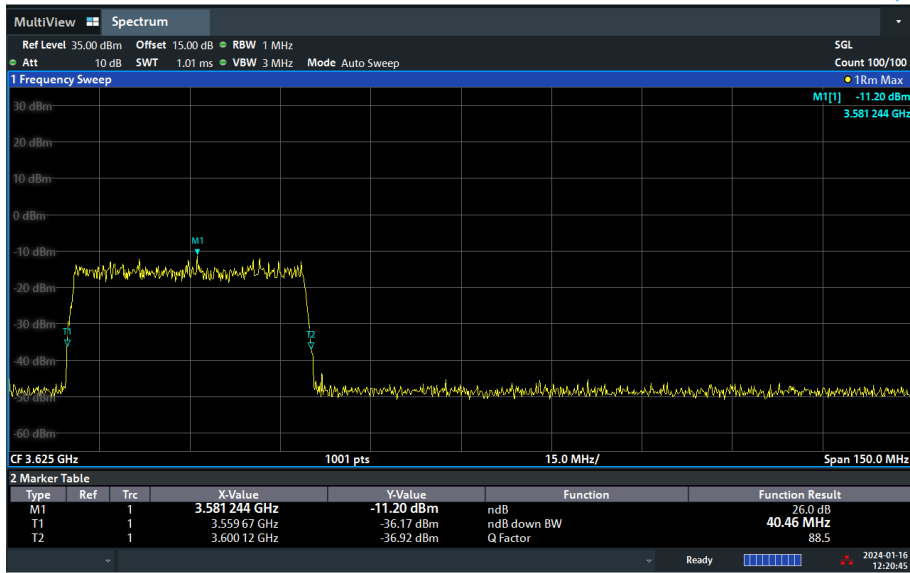

12:20:45 PM 01/16/2024

[Step 4.a.] EUD stops transmission within 10 seconds right after receiving instructions from its associated CBSD.

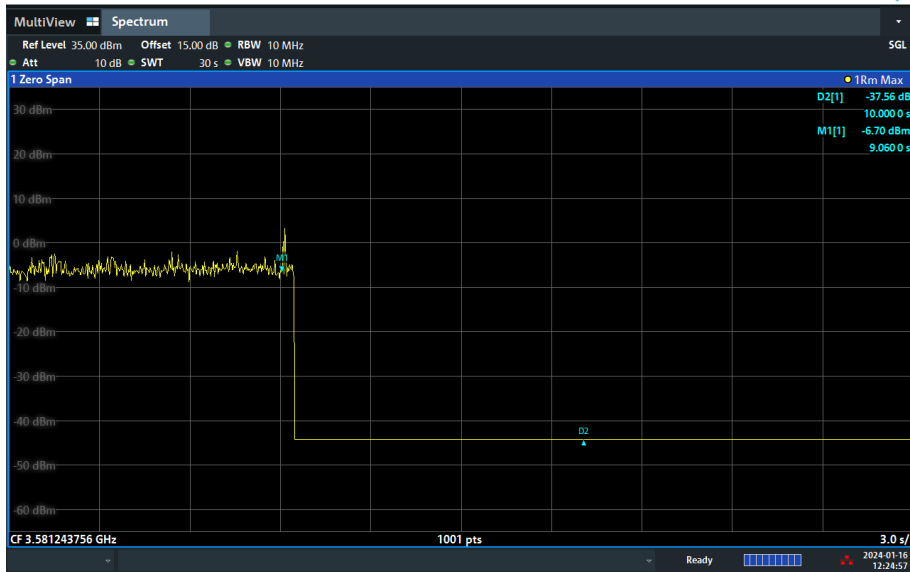

12:24:58 PM 01/16/2024



[Step 5] Configure SAS granted CBSD to operate at frequency 3650-3690 MHz & power level 20 dBm/MHz

[Step 7] Check EUD Tx Frequency and power

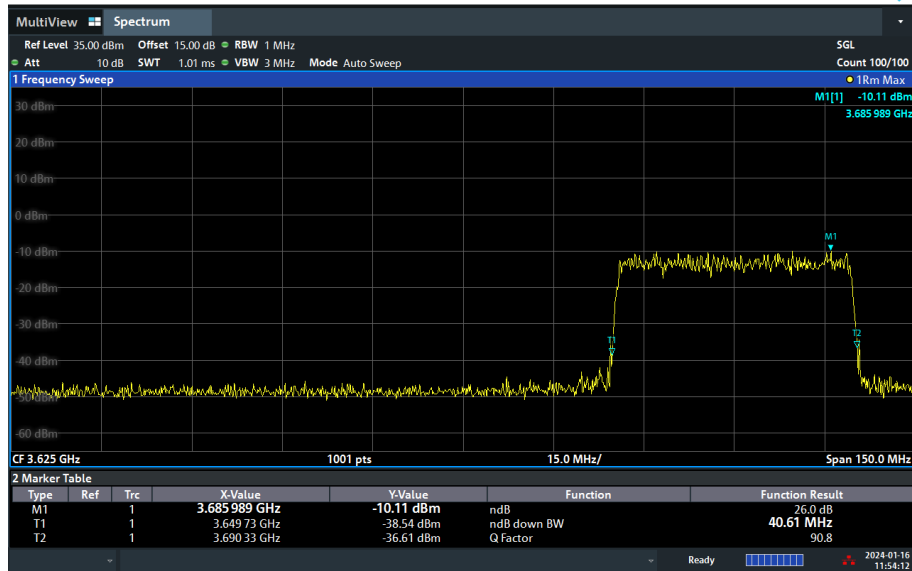

11:54:12 AM 01/16/2024

[Step 8.a.] After changing the frequency and power level,

The EUD discontinues operating, changes frequencies, or changes its operational power level within 10 seconds right after receiving instructions from its associated CBSD. Test result is a PASS.



12:05:55 PM 01/16/2024



4 List of Measuring Equipment

Instrument	Brand Name	Model No.	Serial No.	Characteristics	Calibration Date	Test Date	Due Date	Remark
Spectrum Analyzer	R&S	FSV3044	101433	10Hz~44GHz	Nov. 17, 2023	Jan. 16, 2024	Nov. 16, 2024	Conducted (TH05-HY)

————THE END————