



CERTIFICATION TEST REPORT

Report No. : 15U21863-E1V4

Applicant : GOOGLE
1600 AMPHITHEATRE PARKWAY
MOUNTAIN VIEW, CA 94043, U.S.A

Model : GFRG250

FCC ID : A4RGFRG250

EUT Description : STORAGE NETWORK BOX II, 2TB HD, WIFI AP

Test Standard(s) : FCC 47 CFR PART 15 SUBPART E

Date of Issue:

November 10th, 2016

Prepared by:

UL Verification Services Inc.
47173 Benicia Street
Fremont, CA 94538, U.S.A.
TEL: (510) 771-1000
FAX: (510) 661-0888



NVLAP LAB CODE 200065-0

REVISION HISTORY

Rev.	Issue Date	Revisions	Revised By
V1	09/29/2016	Initial Issue	---
V2	10/07/2016	Updated section 5	---
V3	11/02/2016	<ul style="list-style-type: none">Updated power in sections 4.5.6 – 4.5.8 and 5.1.6 – 5.1.8 for channels 149, 151 and 155 for BF 1 stream mode.Updated power in sections 4.5.7, 4.5.8, 5.1.7 and 5.1.8 for channels 151 and 155 for BF 3 stream mode	Clifford Susa
V4	11/10/2016	Updated section 3.1.	Francisco de Anda

TABLE OF CONTENTS

REVISION HISTORY	2
TABLE OF CONTENTS	3
1. ATTESTATION OF TEST RESULTS	5
2. SUMMARY OF TESTING	6
2.1. <i>FACILITIES AND ACCREDITATION</i>	<i>6</i>
2.2. <i>TEST METHODOLOGY.....</i>	<i>6</i>
2.3. <i>CALIBRATION AND UNCERTAINTY</i>	<i>7</i>
2.4. <i>MEASUREMENT METHOD.....</i>	<i>8</i>
2.5. <i>TEST AND MEASUREMENT EQUIPMENT.....</i>	<i>9</i>
3. EQUIPMENT UNDER TEST	10
3.1. <i>MAXIMUM OUTPUT POWER.....</i>	<i>10</i>
3.2. <i>DESCRIPTION OF AVAILABLE ANTENNAS</i>	<i>11</i>
3.3. <i>SOFTWARE AND FIRMWARE.....</i>	<i>11</i>
3.4. <i>WORST-CASE CONFIGURATION AND MODE.....</i>	<i>11</i>
3.5. <i>DESCRIPTION OF TEST SETUP.....</i>	<i>12</i>
4. ANTENNA PORT TEST RESULTS	17
4.1. <i>ON TIME AND DUTY CYCLE.....</i>	<i>17</i>
4.1.1. <i>RESULTS</i>	<i>17</i>
4.2. <i>26 dB BANDWIDTH.....</i>	<i>22</i>
4.2.1. <i>802.11a MODE IN THE 5.2 GHz BAND.....</i>	<i>22</i>
4.2.2. <i>802.11ac VHT20 MODE IN THE 5.2 GHz BAND</i>	<i>25</i>
4.2.3. <i>802.11ac VHT40 MODE IN THE 5.2 GHz BAND</i>	<i>28</i>
4.2.4. <i>802.11ac VHT80 MODE IN THE 5.2 GHz BAND</i>	<i>30</i>
4.2.5. <i>802.11a MODE IN THE 5.8 GHz BAND.....</i>	<i>31</i>
4.2.6. <i>802.11ac VHT20 MODE IN THE 5.8 GHz BAND</i>	<i>34</i>
4.2.7. <i>802.11ac VHT40 MODE IN THE 5.8 GHz BAND</i>	<i>37</i>
4.2.8. <i>802.11ac VHT80 MODE IN THE 5.8 GHz BAND</i>	<i>39</i>
4.3. <i>99% BANDWIDTH.....</i>	<i>40</i>
4.3.1. <i>802.11a MODE IN THE 5.2 GHz BAND.....</i>	<i>41</i>
4.3.2. <i>802.11ac VHT20 MODE IN THE 5.2 GHz BAND</i>	<i>44</i>
4.3.3. <i>802.11ac VHT40 MODE IN THE 5.2 GHz BAND</i>	<i>47</i>
4.3.4. <i>802.11ac VHT80 MODE IN THE 5.2 GHz BAND</i>	<i>49</i>
4.3.5. <i>802.11a MODE IN THE 5.8 GHz BAND.....</i>	<i>50</i>
4.3.6. <i>802.11ac VHT20 MODE IN THE 5.8 GHz BAND</i>	<i>53</i>
4.3.7. <i>802.11ac VHT40 MODE IN THE 5.8 GHz BAND</i>	<i>56</i>
4.3.8. <i>802.11ac VHT80 MODE IN THE 5.8 GHz BAND</i>	<i>58</i>
4.4. <i>6 dB BANDWIDTH.....</i>	<i>59</i>
4.4.1. <i>802.11a MODE IN THE 5.8 GHz BAND.....</i>	<i>60</i>

4.4.2.	802.11ac VHT20 MODE IN THE 5.8 GHz BAND	63
4.4.3.	802.11ac VHT40 MODE IN THE 5.8 GHz BAND	66
4.4.4.	802.11ac VHT80 MODE IN THE 5.8 GHz BAND	68
4.5.	<i>OUTPUT POWER AND PPSD</i>	69
4.5.1.	802.11a MODE IN THE 5.2 GHz BAND	71
4.5.2.	802.11ac VHT20 MODE IN THE 5.2 GHz BAND	75
4.5.3.	802.11ac VHT40 MODE IN THE 5.2 GHz BAND	91
4.5.4.	802.11ac VHT80 MODE IN THE 5.2 GHz BAND	103
4.5.5.	802.11a MODE IN THE 5.8 GHz BAND.....	111
4.5.6.	802.11ac VHT20 MODE IN THE 5.8 GHz BAND (low channel 1 stream BF)	118
4.5.7.	802.11ac VHT40 MODE IN THE 5.8 GHz BAND (low channel 3 stream and 1 stream BF)	146
4.5.8.	802.11ac VHT80 MODE IN THE 5.8 GHz BAND (3 and 1 stream BF).....	166
5.	RADIATED TEST RESULTS	178
5.1.	<i>TRANSMITTER ABOVE 1 GHz</i>	179
5.1.1.	802.11a MODE IN THE 5.2GHz BAND.....	179
5.1.2.	802.11ac VHT20 MODE IN THE 5.2GHz BAND	187
5.1.3.	802.11ac VHT40 MODE IN THE 5.2GHz BAND	219
5.1.4.	802.11ac VHT80 MODE IN THE 5.2GHz BAND	243
5.1.5.	802.11a MODE IN THE 5.8GHz BAND.....	259
5.1.6.	802.11ac VHT20 MODE IN THE 5.8GHz BAND (1 stream BF mode low channel) 269	
5.1.7.	802.11ac VHT40 MODE IN THE 5.8GHz BAND (low channel 3 stream and 1 stream BF)	309
5.1.8.	802.11ac VHT80 MODE IN THE 5.8GHz BAND (3 and 1 stream BF).....	341
5.2.	<i>WORST-CASE BELOW 1 GHz</i>	365
5.3.	<i>WORST-CASE ABOVE 18 GHz</i>	369
5.3.1.	SPURIOUS EMISSIONS 18 TO 26 GHz (WORST-CASE CONFIGURATION) ..	369
5.3.2.	SPURIOUS EMISSIONS 26 TO 40 GHz (WORST-CASE CONFIGURATION) ..	371
6.	AC POWER LINE CONDUCTED EMISSIONS	373
7.	SETUP PHOTOS	378

1. ATTESTATION OF TEST RESULTS

COMPANY NAME: GOOGLE
1600 AMPHITHEATRE PARKWAY
MOUNTAIN VIEW, CA 94043, U.S.A

EUT DESCRIPTION: STORAGE NETWORK BOX II, 2TB HD, WIFI AP

MODEL: GFRG250

SERIAL NUMBER: BFAFSJ1538E0015, BFAFSJ1546E0047

DATE TESTED: October 22nd, 2015 to November 1st, 2016

APPLICABLE STANDARDS	
STANDARD	TEST RESULTS
CFR 47 Part 15 Subpart E	Pass

UL Verification Services Inc. tested the above equipment in accordance with the requirements set forth in the above standards. All indications of Pass/Fail in this report are opinions expressed by UL Verification Services Inc. based on interpretations and/or observations of test results. Measurement Uncertainties were not taken into account and are published for informational purposes only. The test results show that the equipment tested is capable of demonstrating compliance with the requirements as documented in this report.

Note: The results documented in this report apply only to the tested sample, under the conditions and modes of operation as described herein. This document may not be altered or revised in any way unless done so by UL Verification Services Inc. and all revisions are duly noted in the revisions section. Any alteration of this document not carried out by UL Verification Services Inc. will constitute fraud and shall nullify the document. This report must not be used by the client to claim product certification, approval, or endorsement by NVLAP, NIST, any agency of the Federal Government, or any agency of any government.

Approved & Released For
UL Verification Services Inc. By:



FRANCISCO DE ANDA
CONSUMER TECHNOLOGY DIVISION
PROJECT MANAGER
UL Verification Services Inc.

Prepared By:



CLIFFORD SUSA
CONSUMER TECHNOLOGY DIVISION
EMC ENGINEER
UL Verification Services Inc.

2. SUMMARY OF TESTING

2.1. FACILITIES AND ACCREDITATION

The test sites and measurement facilities used to collect data are located at 47173 and 47266 Benicia Street, Fremont, California, USA. Line conducted emissions are measured only at the 47173 address. The following table identifies which facilities were utilized for radiated emission measurements documented in this report. Specific facilities are also identified in the test results sections.

47173 Benicia Street	47266 Benicia Street
<input checked="" type="checkbox"/> Chamber A(IC: 2324B-1)	<input type="checkbox"/> Chamber D(IC: 2324B-4)
<input checked="" type="checkbox"/> Chamber B(IC: 2324B-2)	<input type="checkbox"/> Chamber E(IC: 2324B-5)
<input type="checkbox"/> Chamber C(IC: 2324B-3)	<input type="checkbox"/> Chamber F(IC: 2324B-6)
	<input type="checkbox"/> Chamber G(IC: 2324B-7)
	<input checked="" type="checkbox"/> Chamber H(IC: 2324B-8)

UL Verification Services Inc. is accredited by NVLAP, Laboratory Code 200065-0. The full scope of accreditation can be viewed at <http://ts.nist.gov/standards/scopes/2000650.htm>.

2.2. TEST METHODOLOGY

The tests documented in this report were performed in accordance with FCC CFR 47 Part 2, FCC CFR 47 Part 15, FCC 14-30, FCC KDB 662911 D01 v02r01, FCC KDB 789033 D02 v01r02, FCC KDB 644545 D03 v01, ANSI C63.10-2013.

2.3. CALIBRATION AND UNCERTAINTY

MEASURING INSTRUMENT CALIBRATION

The measuring equipment utilized to perform the tests documented in this report has been calibrated in accordance with the manufacturer's recommendations, and is traceable to recognized national standards.

SAMPLE CALCULATION

Where relevant, the following sample calculation is provided:

$$\begin{aligned} \text{Field Strength (dBuV/m)} &= \text{Measured Voltage (dBuV)} + \text{Antenna Factor (dB/m)} + \\ &\text{Cable Loss (dB)} - \text{Preamp Gain (dB)} \\ 36.5 \text{ dBuV} + 18.7 \text{ dB/m} + 0.6 \text{ dB} - 26.9 \text{ dB} &= 28.9 \text{ dBuV/m} \end{aligned}$$

MEASUREMENT UNCERTAINTY

Where relevant, the following measurement uncertainty levels have been estimated for tests performed on the apparatus:

Parameter	Uncertainty
Worst Case Conducted Disturbance, 9KHz to 0.15 MHz	3.84 dB
Worst Case Conducted Disturbance, 0.15 to 30 MHz	3.65 dB
Worst Case Radiated Disturbance, 9KHz to 30 MHz	3.15 dB
Worst Case Radiated Disturbance, 30 to 1000 MHz	5.36 dB
Worst Case Radiated Disturbance, 1000 to 18000 MHz	4.32 dB
Worst Case Radiated Disturbance, 18000 to 26000 MHz	4.45 dB
Worst Case Radiated Disturbance, 26000 to 40000 MHz	5.24 dB

Uncertainty figures are valid to a confidence level of 95%.

2.4. MEASUREMENT METHOD

On Time and Duty Cycle: KDB 789033 D02 v01r02, Section B

6 dB Emission BW: KDB 789033 D02 v01 r02, Section C2.

26 dB Emission BW: KDB 789033 D02 v01 r02, Section C.

99% Occupied BW: KDB 789033 D02 v01 r02, Section D.

Conducted Output Power: KDB 789033 D02 v01 r02, Section E.2.d (Method SA-2).

Power Spectral Density: KDB 789033 D02 v01 r02, Section F.

Unwanted emissions in restricted bands: KDB 789033 D02 v01 r02, Sections G.3, G.4, G.5, and G.6.

Unwanted emissions in non-restricted bands: KDB 789033 D02 v01 r02, Sections G.3, G.4, and G.5.

AC Power Line Conducted Emissions: ANSI C63.10-2009, Section 6.2.

2.5. TEST AND MEASUREMENT EQUIPMENT

The following test and measurement equipment was utilized for the tests documented in this report:

Test Equipment List				
Description	Manufacturer	Model	ID Num	Cal Due
Spectrum Analyzer, 44 GHz	Keysight	N9030A	PRE126763	12/09/16
Spectrum Analyzer, 44 GHz	Keysight	N9030A	T917	06/30/16
Spectrum Analyzer, 44 GHz	Keysight	N9030A	T907	01/06/17
Spectrum Analyzer, 44 GHz	Keysight	N9030A	T906	02/03/17
Spectrum Analyzer, 40GHz	Keysight	8564E	T106	08/14/16
Spectrum Analyzer, 26.5 GHz	Keysight	E4440A	T200	09/02/16
EMI Test Receiver, 9 kHz-7 GHz	R & S	ESCI 7	T284	09/10/16
EMI Test Receiver, 9 kHz-7 GHz	R & S	ESCR 7	T1436	12/19/16
Antenna, Horn, 1-18 GHz	ETS Lindgren	3117	T863	04/06/17
Antenna, Horn, 1-18 GHz	ETS Lindgren	3117	T346	02/22/17
Antenna, Horn, 1-18 GHz	ETS Lindgren	3117	T345	03/07/17
Antenna, Horn, 1-18 GHz	ETS Lindgren	3117	T120	04/05/17
Antenna, Horn, 18- 26 GHz	ARA	MWH-1826	T447	05/26/16
Antenna, Horn, 26-40 GHz	ARA	MWH-2640	T90	07/28/16
Antenna, Bilog, 30MHz-1 GHz	Sunol Sciences	JB3	T477	06/09/17
RF Preamplifier, 10kHz - 1000MHz	Sonoma	310N	T300	11/05/16
RF Preamplifier, 1GHz - 8GHz	Miteq	AMF-4D-01000800-30-29P	T782	10/21/16
RF Preamplifier, 1GHz - 8GHz	Miteq	AMF-4D-01000800-30-29P	T1156	03/09/17
RF Preamplifier, 1GHz - 7GHz	Ampical	AMP1G7-20-27	T1562	05/17/17
RF Preamplifier, 1GHz - 7GHz	Ampical	AMP1G7-20-27	T1563	09/15/17
RF Preamplifier, 1GHz - 18GHz	Miteq	AFS42-00101800-25-S-42	T493	03/09/17
RF Preamplifier, 1GHz - 18GHz	Miteq	AFS42-00101800-25-S-42	T1172	07/09/16
RF Preamplifier, 1GHz - 18GHz	Miteq	AFS42-00101800-25-S-42	T495	09/15/17
RF Preamplifier, 18GHz - 26.5GHz	Keysight	8449B	T404	06/29/16
RF Preamplifier, 26GHz - 40GHz	Miteq	NSP4000-SP2	T88	04/09/17
Low Pass Filter 5GHz	Micro-Tronics	LPS17541	T891	09/15/17
Low Pass Filter 5GHz	Micro-Tronics	LPS17541	T481	07/09/16
Low Pass Filter 5GHz	Micro-Tronics	LPS17541	T483	03/09/17
High Pass Filter 6GHz	Micro-Tronics	HPS17542	T894	09/15/17
High Pass Filter 6GHz	Micro-Tronics	HPS17542	T484	07/09/16
High Pass Filter 6GHz	Micro-Tronics	HPS17542	T485	03/09/17
LISN	Fischer	FCC-LISN-50/250-25-2-01-C	T1310	09/16/16
Radiated Software	UL	UL EMC	Ver 9.5, April 26, 2016	
Conducted Software	UL	UL EMC	Ver 4.7	

NOTE: *testing is completed before equipment calibration expiration date.

3. EQUIPMENT UNDER TEST

3.1. MAXIMUM OUTPUT POWER

The transmitter has a maximum conducted output power as follows:

5.2 GHz BAND

Frequency Range (MHz)	Mode	Total Output Power (dBm)	Total Output Power (mW)
4TX CDD			
5180 - 5240	802.11a	24.17	261.22
5180 - 5240	802.11n VHT20	27.26	532.11
5190 - 5230	802.11n VHT40	27.75	595.66
5210	802.11ac VHT80	22.42	174.58
4TX BF			
5180 - 5240	802.11n VHT20	27.73	592.93
5190 - 5230	802.11n VHT40	28.98	790.68
5210	802.11ac VHT80	21.21	132.13

5.8 GHz BAND

Frequency Range (MHz)	Mode	Total Output Power (dBm)	Total Output Power (mW)
4TX CDD			
5745 - 5825	802.11a	26.17	414.00
5745 - 5825	802.11n VHT20	26.01	399.02
5755 - 5795	802.11n VHT40	25.59	362.24
5775	802.11ac VHT80	20.63	115.61
4TX BF			
5745 - 5825	802.11n VHT20	26.71	468.81
5755 - 5795	802.11n VHT40	28.35	683.91
5775	802.11ac VHT80	27.47	558.47

List of test reduction

Antenna Port & Radiated Testing		
Band	Mode	Covered by
5 GHz bands	802.11n HT20 CDD 4TX	802.11ac VHT20 CDD 4TX
5 GHz bands	802.11n HT40 CDD 4TX	802.11ac VHT40 CDD 4TX

3.2. DESCRIPTION OF AVAILABLE ANTENNAS

Frequency Band (GHz)	Directional Antenna Gain			
	1	2	3	4
	Spatial Stream (dBi)	Spatial Streams (dBi)	Spatial Streams (dBi)	Spatial Streams (dBi)
5.2	9.92	6.95	6.03	3.98
5.8	9.95	6.99	6.07	4.01

3.3. SOFTWARE AND FIRMWARE

The firmware installed in the EUT during testing was version: V37.4.0.46.

The SW installed in the EUT during testing was version: Linux version 3.2.26

3.4. WORST-CASE CONFIGURATION AND MODE

Radiated emission and power line conducted emission were performed with the EUT set to transmit at the channel with highest output power as worst-case scenario. The EUT was also evaluated according to ANSIC 63.10:2013, Clause 5.10.7 for external accessories. Reported is only the worst case configuration.

Based on the baseline scan, the worst-case data rates were:

802.11a mode: MCS0
802.11ac VHT20 mode: MCS0
802.11ac VHT40 mode: MCS0
802.11ac VHT80 mode: MCS0

802.11ac VHT20 and VHT40 mode are different from 802.11nHT20 and HT40 only in control messages and have the same power settings.

3.5. DESCRIPTION OF TEST SETUP

SUPPORT EQUIPMENT

Support Equipment List				
Description	Manufacturer	Model	Serial Number	FCC ID
EUT AC Adapter	Liteon	PB-1600-29	9T54 E132068	N/A
EUT AC Adapter	Acbel	OTD018	7Z00 E131875	N/A
Storage network box	Google	GFRG250	BFAFSJ1538E0020	N/A
Laptop	Lenovo	T440	PC-00TFVU	DoC
Laptop AC Adapter	Lenovo	ADLX65NDC2A	11S36200282ZZ20048SD3S	N/A
USB-Serial adapter	Trip-Lite	USA-19HS	2448ATRCU791104077	N/A

I/O CABLES

I/O Cable List						
Cable No	Port	# of identical ports	Connector Type	Cable Type	Cable Length (m)	Remarks
1	DC	1	Barrel	unshielded	2.7	N/A
2	DC	1	Barrel	unshielded	1.8	N/A
3	USB	1	USB	unshielded	2.8	N/A
4	Serial	1	Serial	unshielded	0.35	N/A

TEST SETUP

The EUT was connected to a host Laptop via USB – Serial cable adapter. Test software exercised the EUT.

SETUP DIAGRAM FOR CONDUCTED TESTS

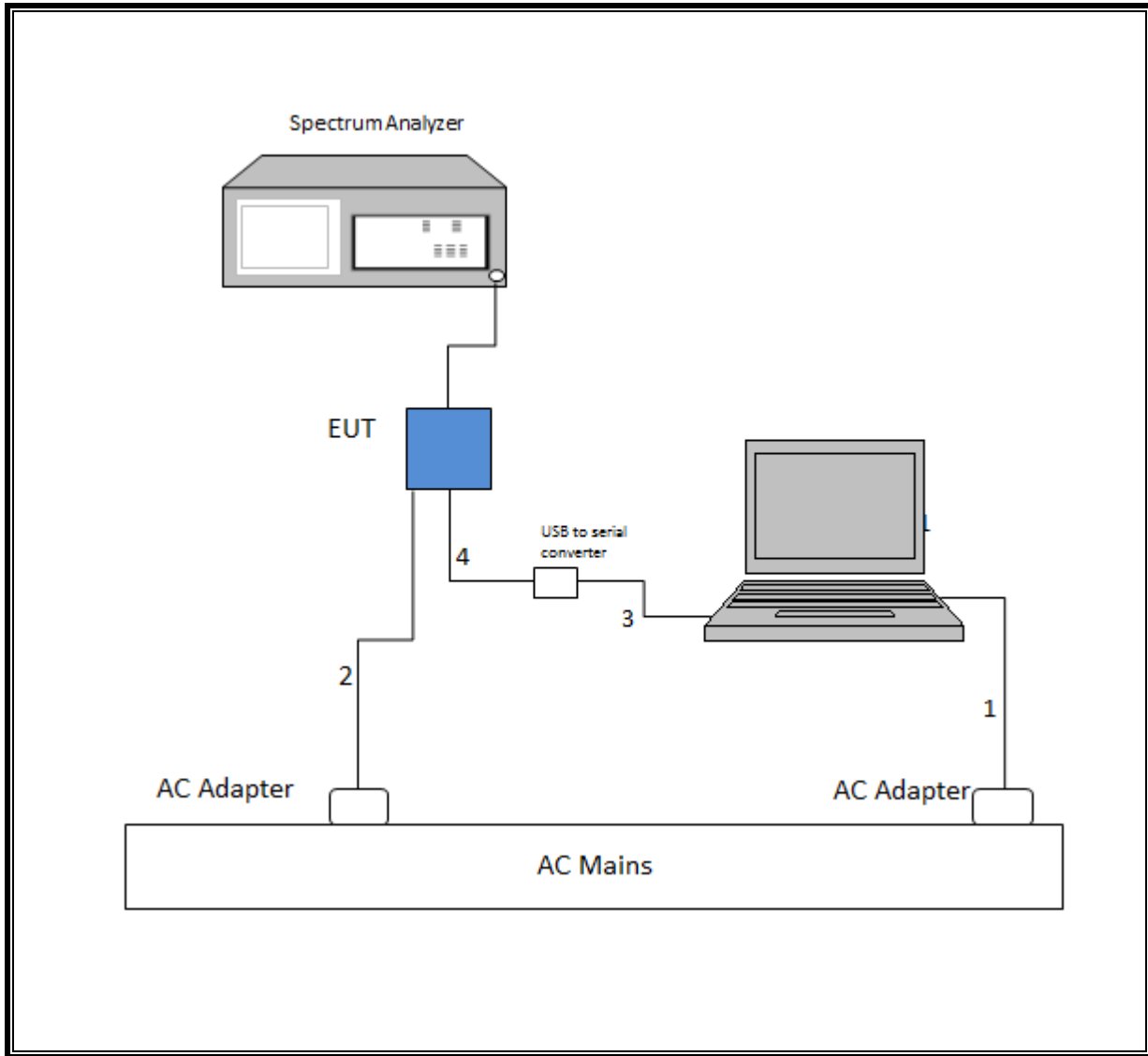

SETUP DIAGRAM FOR RADIATED TESTS

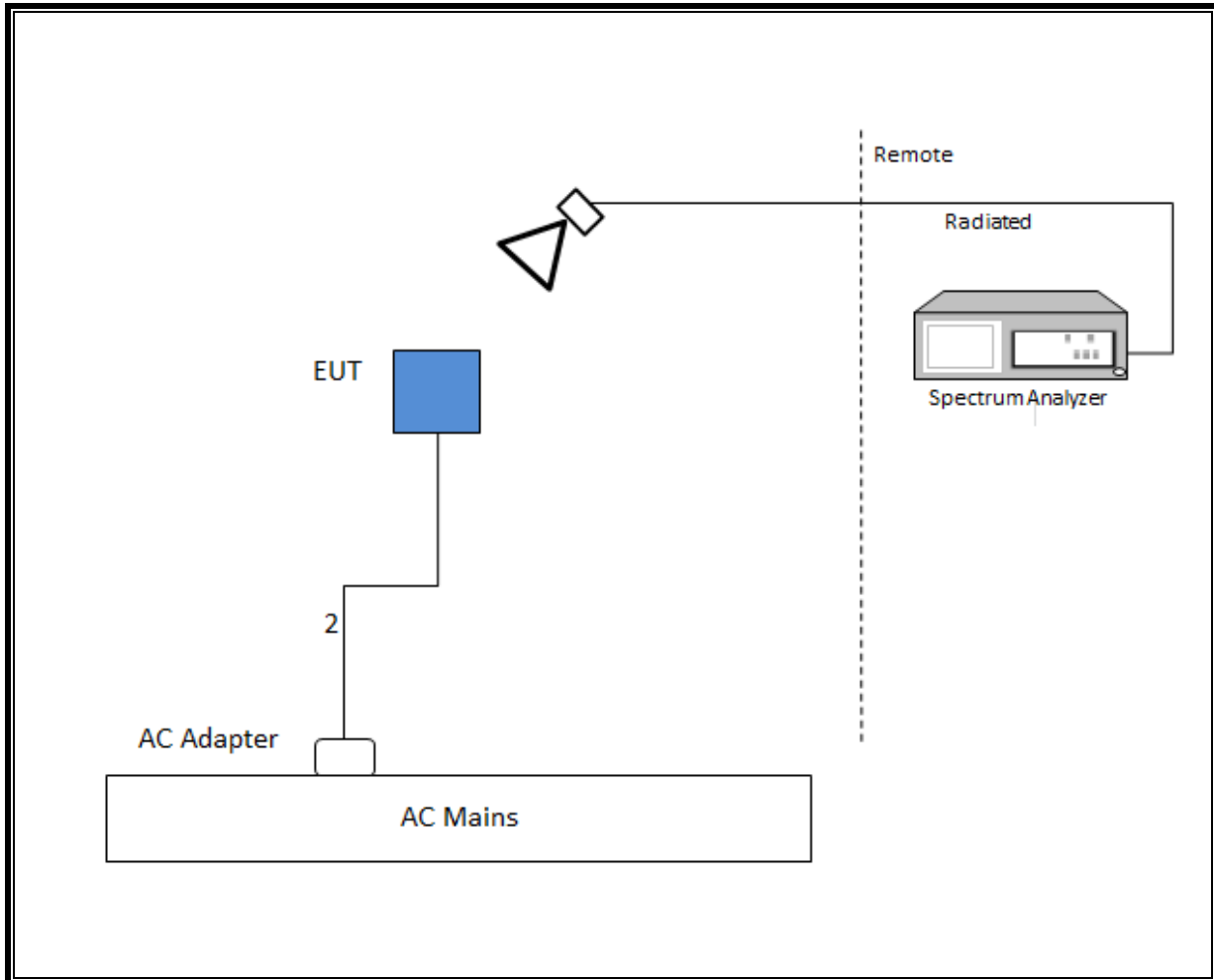

SETUP DIAGRAM FOR RADIATED TESTS - Beamforming Mode

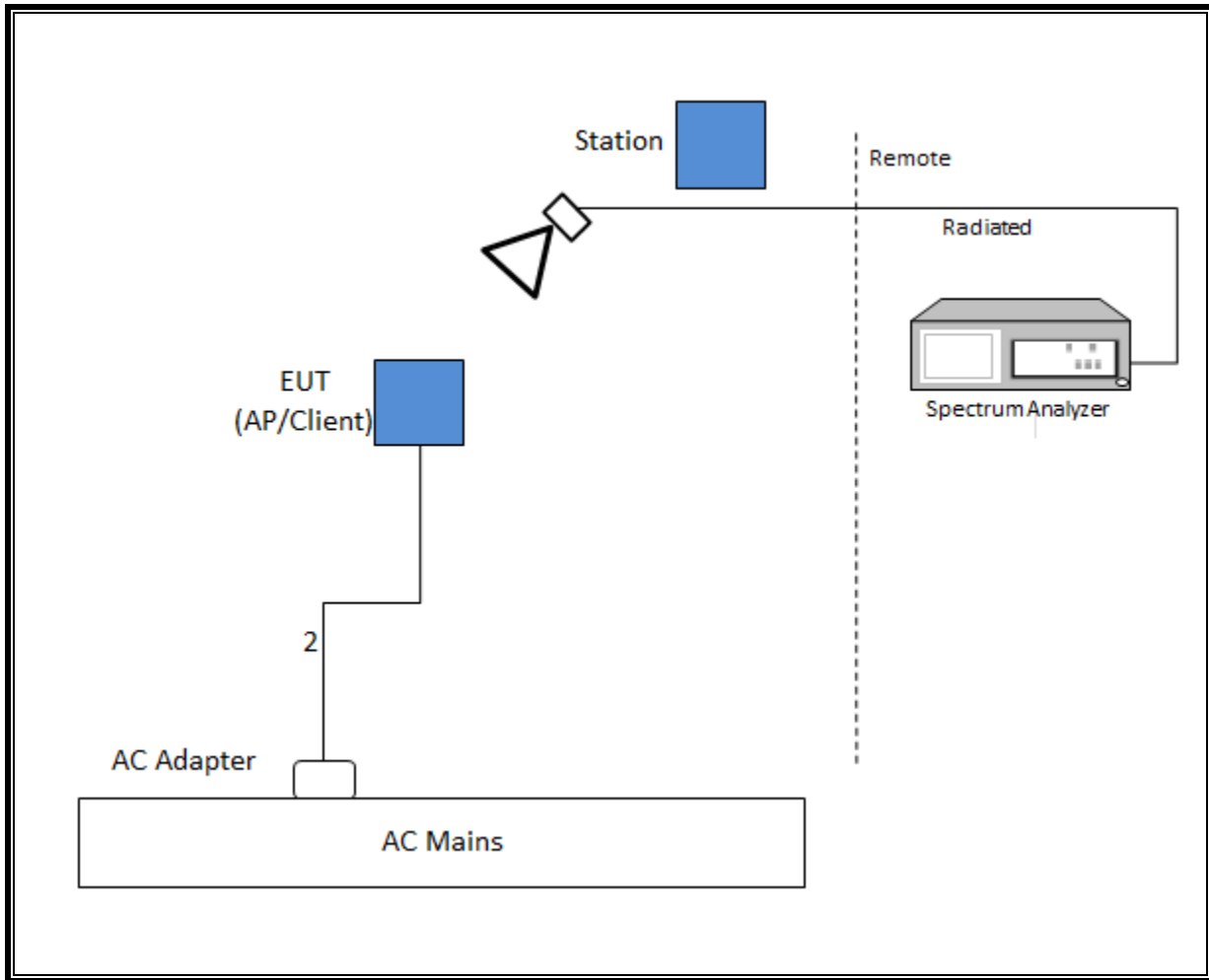

SETUP DIAGRAM FOR LINE CONDUCTED TEST

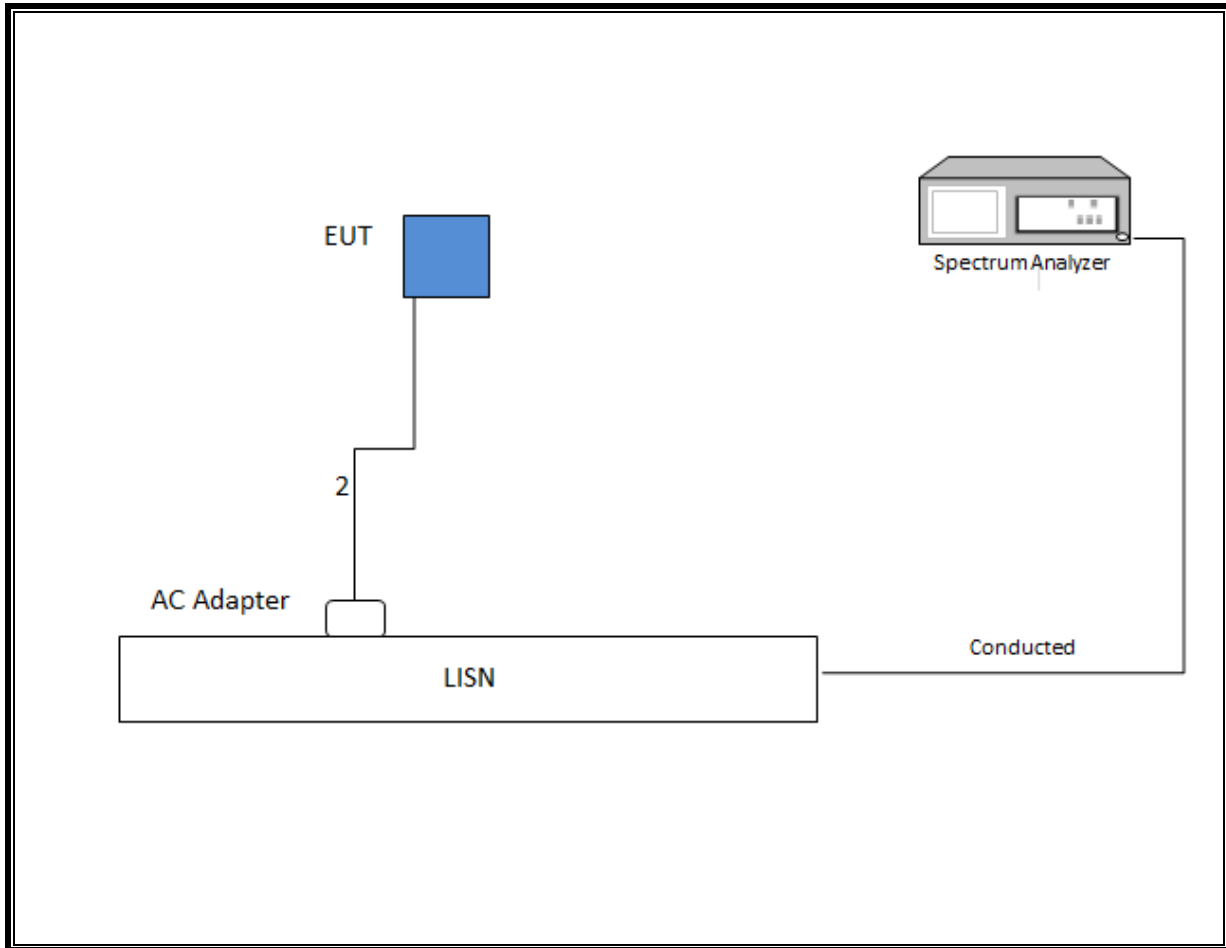

4. ANTENNA PORT TEST RESULTS

4.1. ON TIME AND DUTY CYCLE

LIMITS

None; for reporting purposes only.

PROCEDURE

KDB 789033 Zero-Span Spectrum Analyzer Method.

4.1.1. RESULTS

Mode	ON Time B (msec)	Period (msec)	Duty Cycle x (linear)	Duty Cycle (%)	Duty Cycle Correction Factor (dB)	1/T Minimum VBW (kHz)
4Tx 4 STREAM CDD MODE						
802.11ac VHT20	1.286	1.340	0.960	96.0%	0.18	0.778
802.11ac VHT40	0.648	0.697	0.930	93.0%	0.32	1.543
802.11ac VHT80	0.328	0.387	0.847	84.7%	0.72	3.053
4Tx 1 STREAM CDD MODE						
802.11a	0.563	0.604	0.932	93.2%	0.31	1.777
802.11ac VHT20	4.907	5.000	0.981	98.1%	0.00	0.010
802.11ac VHT40	2.423	2.510	0.965	96.5%	0.15	0.413
802.11ac VHT80	1.134	1.201	0.944	94.4%	0.25	0.882
4Tx 3 STREAM BF MODE						
802.11ac VHT20	11.050	12.380	0.893	89.3%	0.49	0.090
802.11ac VHT40	6.705	8.090	0.829	82.9%	0.82	0.149
802.11ac VHT80	11.710	13.600	0.861	86.1%	0.65	0.085
4Tx 1 STREAM BF MODE						
802.11ac VHT20	10.480	12.250	0.856	85.6%	0.68	0.095
802.11ac VHT40	5.000	6.455	0.775	77.5%	1.11	0.200
802.11ac VHT80	4.246	5.123	0.829	82.9%	0.82	0.236

Tested by: 37699 CS

Test Date: 10/22/15 – 6/1/16

4Tx 4 STREAM CDD MODE DUTY CYCLE PLOTS

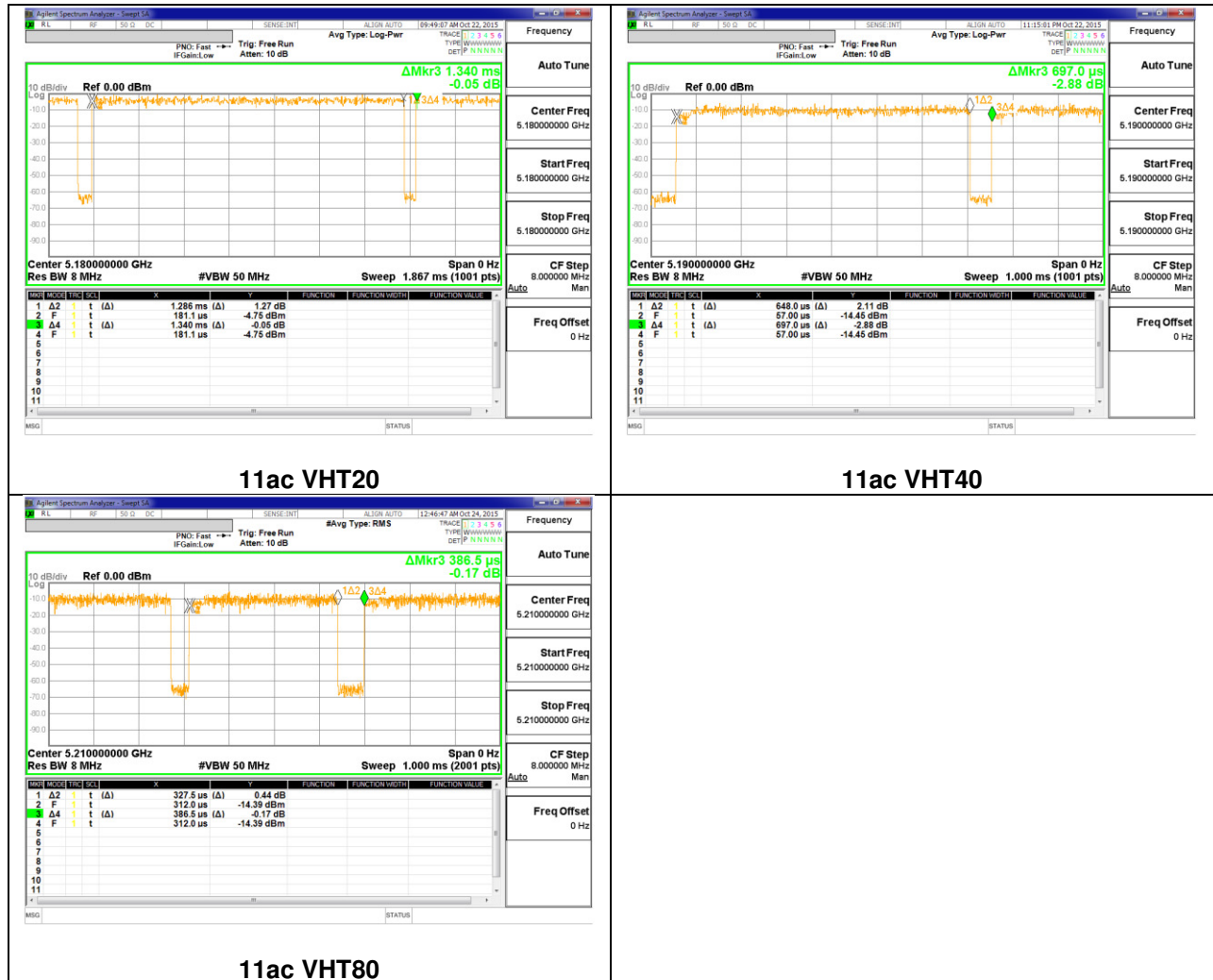

4Tx 1 STREAM CDD MODE DUTY CYCLE PLOTS



4Tx 3 STREAM BF MODE DUTY CYCLE PLOTS

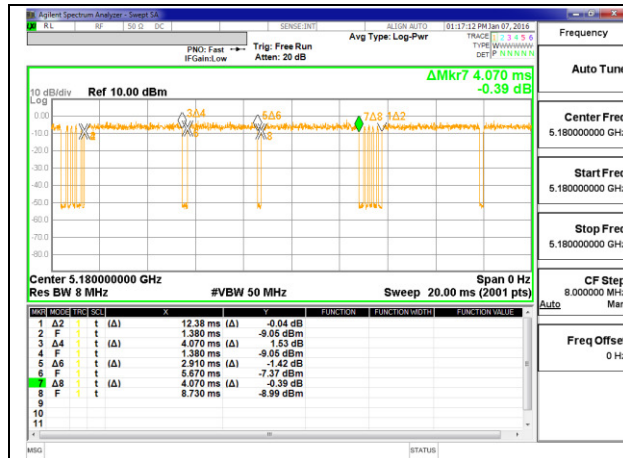

11ac VHT20

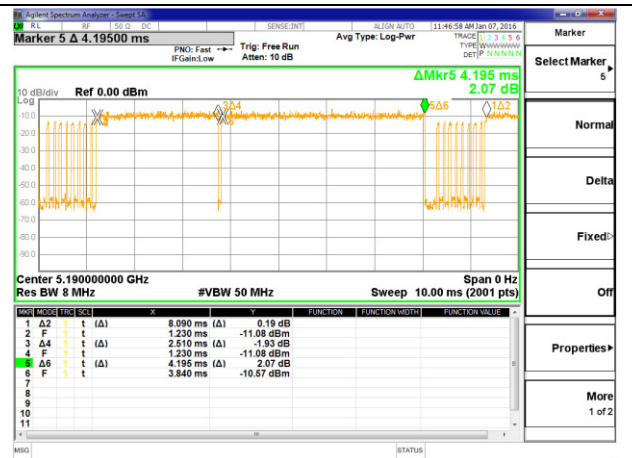

11ac VHT40

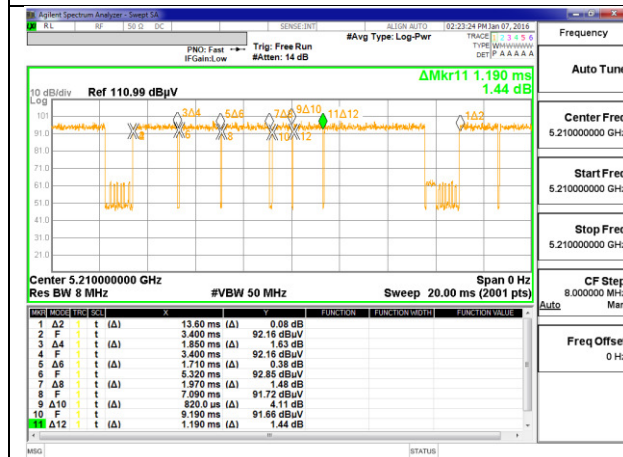

11ac VHT80 (PART 1 of 2)

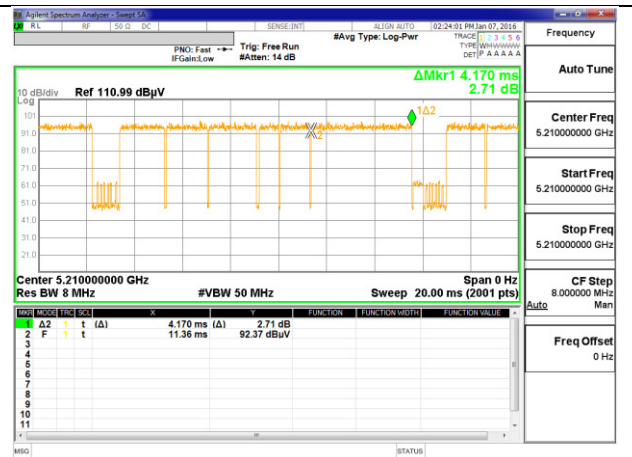

11ac VHT80 (PART 2 of 2)

4Tx 1 STREAM BF MODE DUTY CYCLE PLOTS

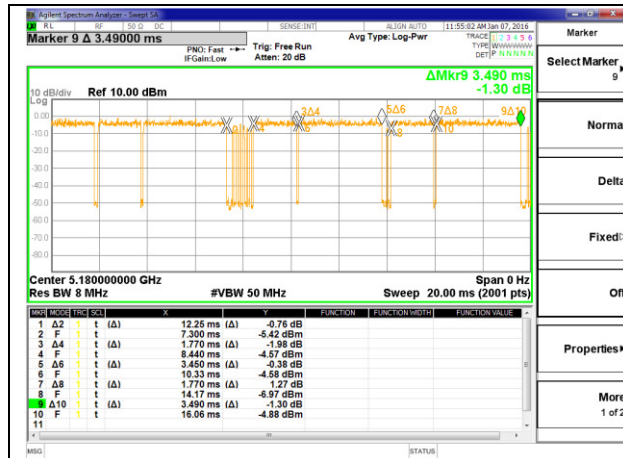

11ac VHT20

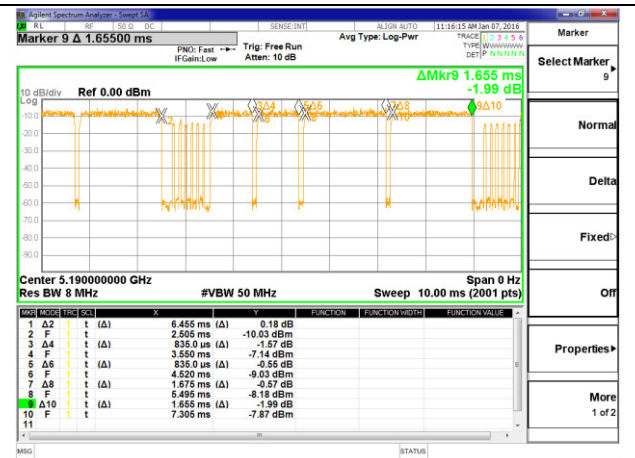

11ac VHT40

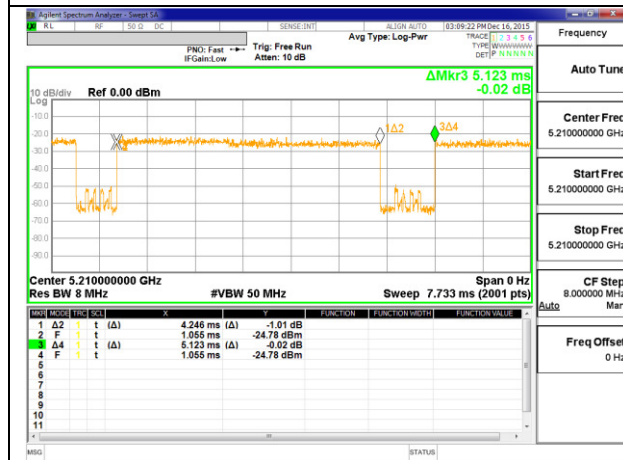

11ac VHT80

4.2. 26 dB BANDWIDTH

LIMITS

None; for reporting purposes only.

RESULTS

4.2.1. 802.11a MODE IN THE 5.2 GHz BAND

Channel	Frequency (MHz)	26 dB Bandwidth Chain 0 (MHz)	26 dB Bandwidth Chain 1 (MHz)	26 dB Bandwidth Chain 2 (MHz)	26 dB Bandwidth Chain 3 (MHz)
Low	5180	23.544	23.688	23.652	23.652
Mid	5200	23.400	23.544	23.688	23.544
High	5240	23.940	23.508	23.544	23.508

4Tx CDD MODE

LOW CHANNEL

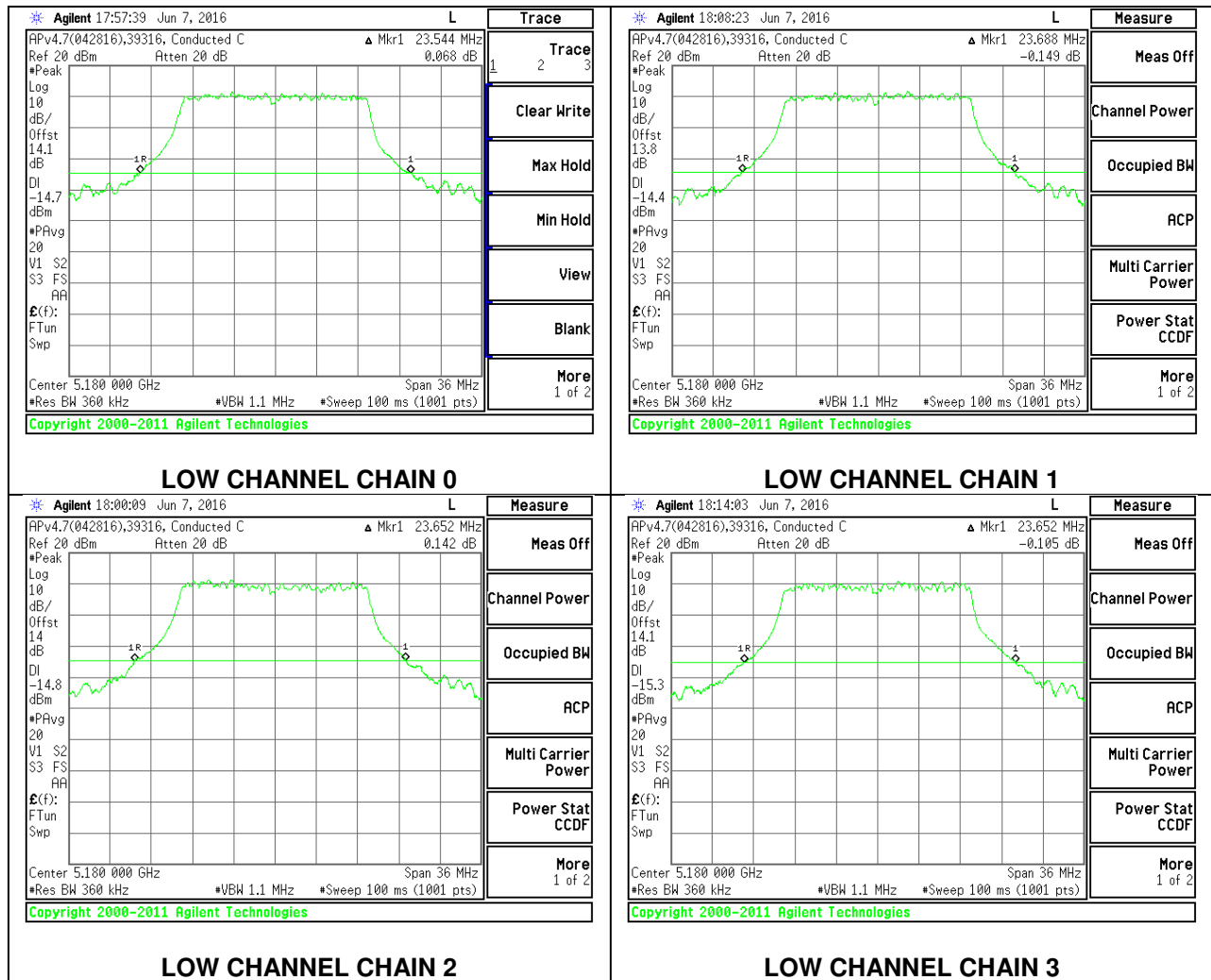

MID CHANNEL

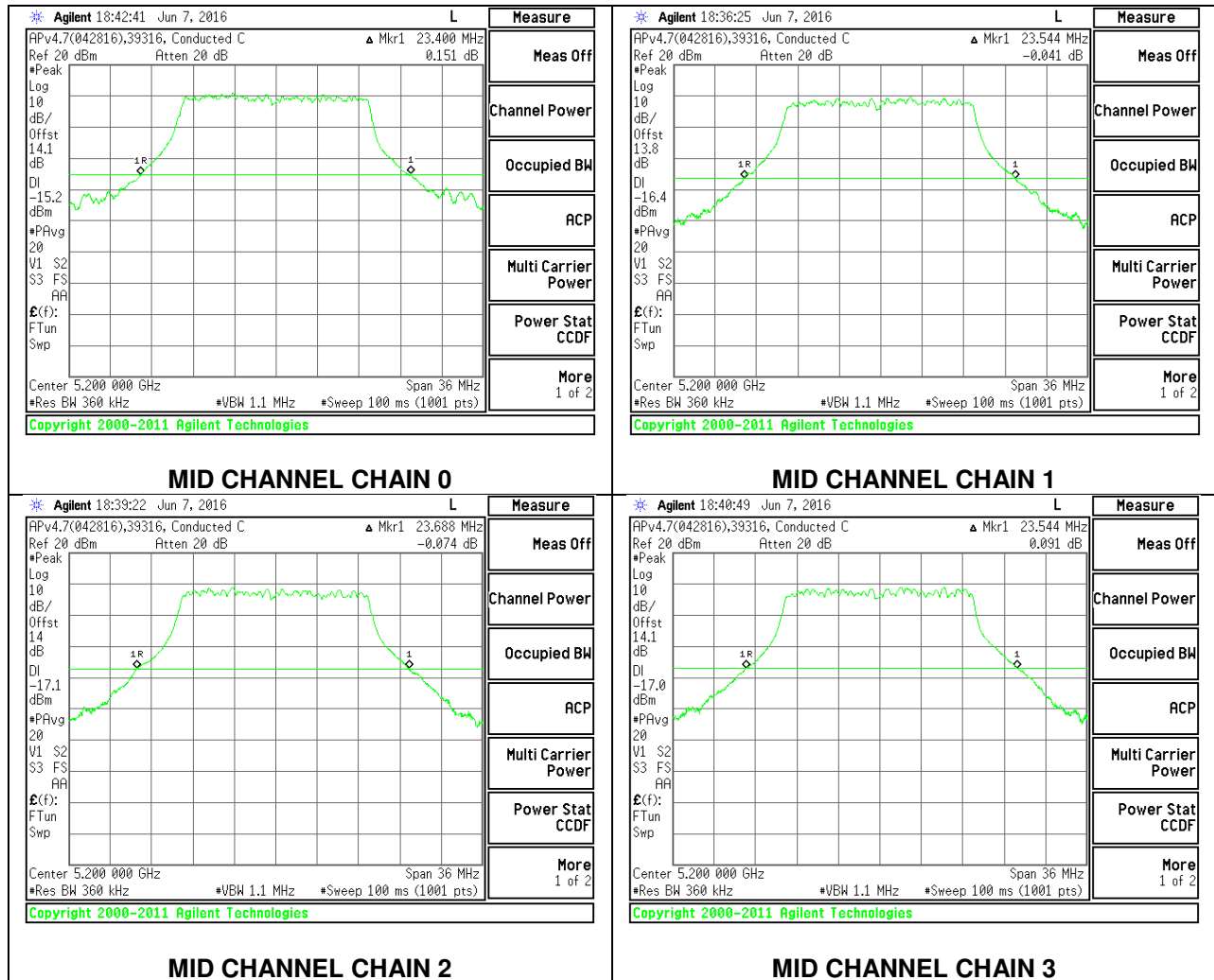

HIGH CHANNEL

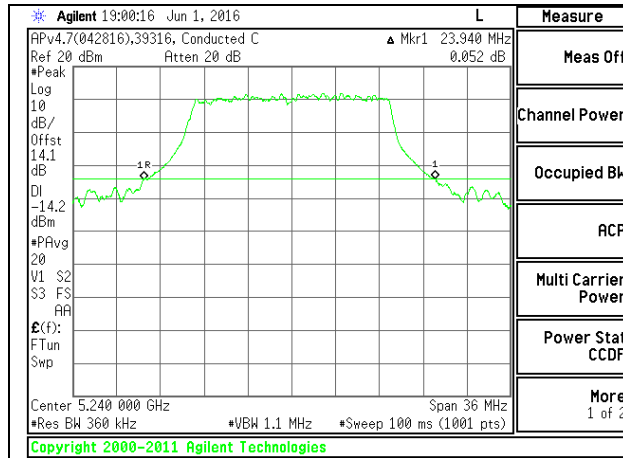

HIGH CHANNEL CHAIN 0

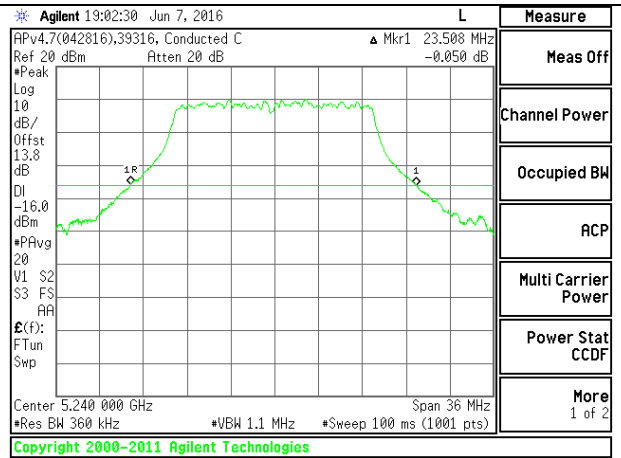

HIGH CHANNEL CHAIN 1

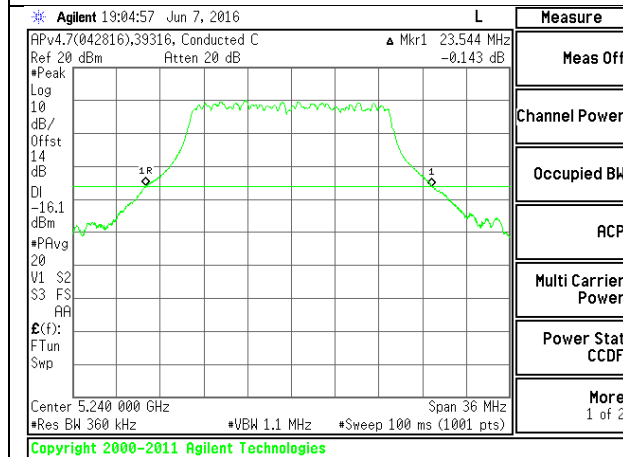

HIGH CHANNEL CHAIN 2

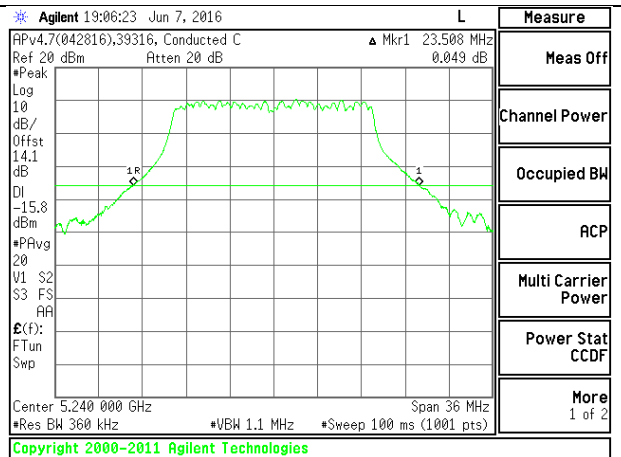

HIGH CHANNEL CHAIN 3

4.2.2. 802.11ac VHT20 MODE IN THE 5.2 GHz BAND

Channel	Frequency (MHz)	26 dB Bandwidth Chain 0 (MHz)	26 dB Bandwidth Chain 1 (MHz)	26 dB Bandwidth Chain 2 (MHz)	26 dB Bandwidth Chain 3 (MHz)
Low	5180	23.135	23.796	23.135	23.796
Mid	5200	22.680	23.940	22.338	22.925
High	5240	22.785	23.760	23.205	23.400

Test By: 39316 CX
 Test Date: 10/23/15

4Tx CDD MODE

LOW CHANNEL

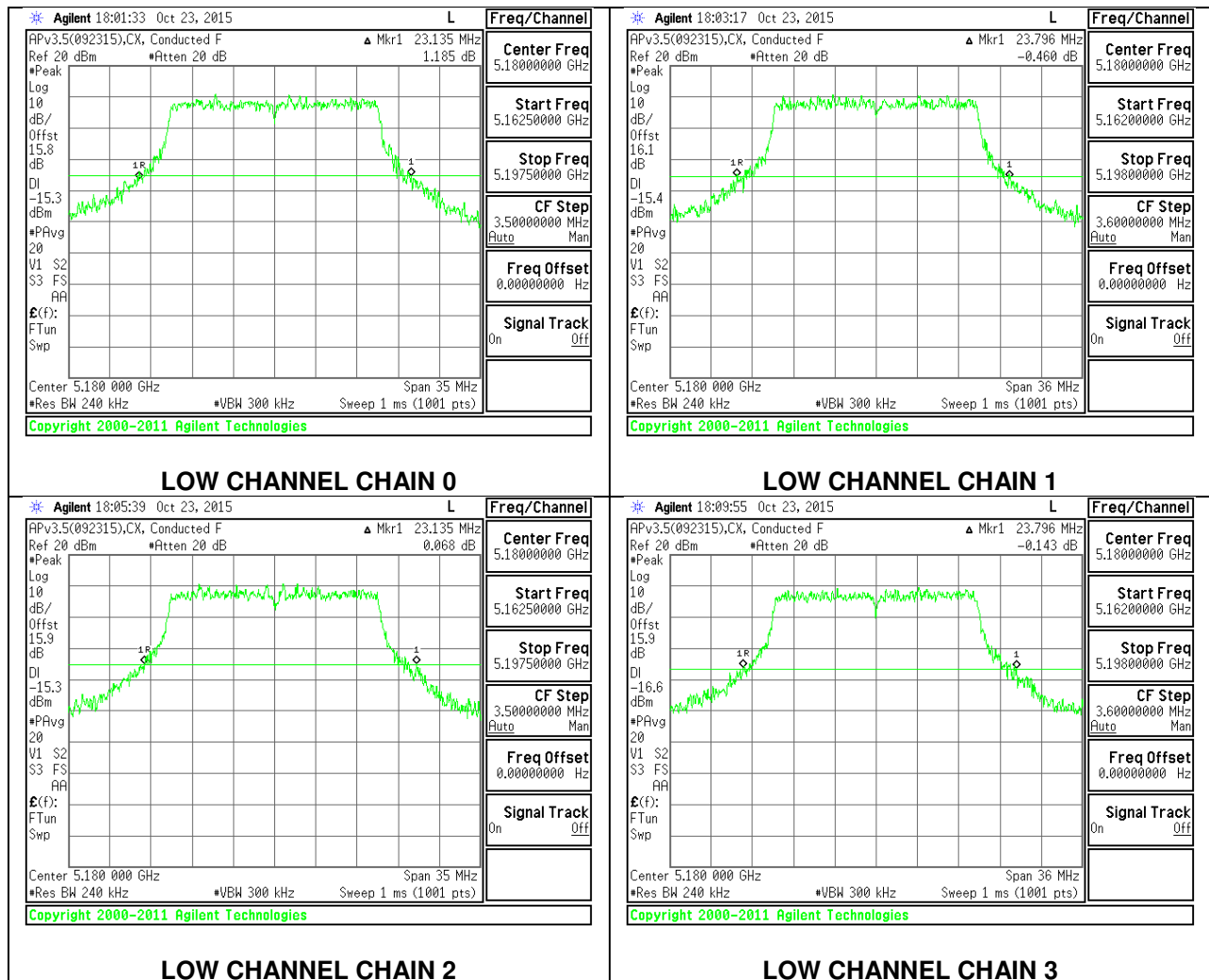

MID CHANNEL

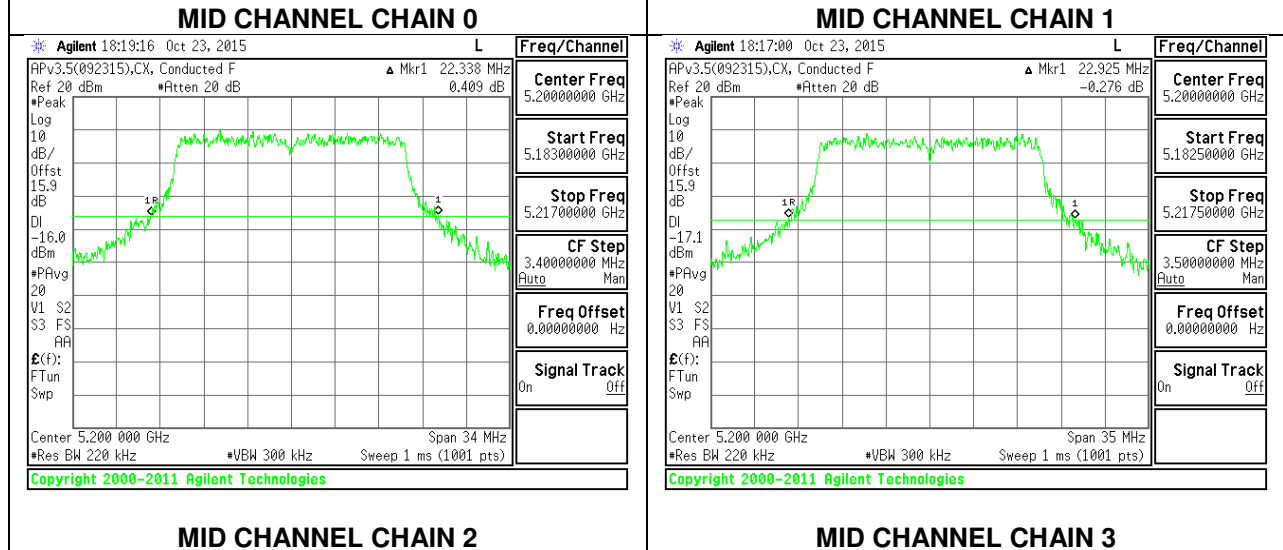
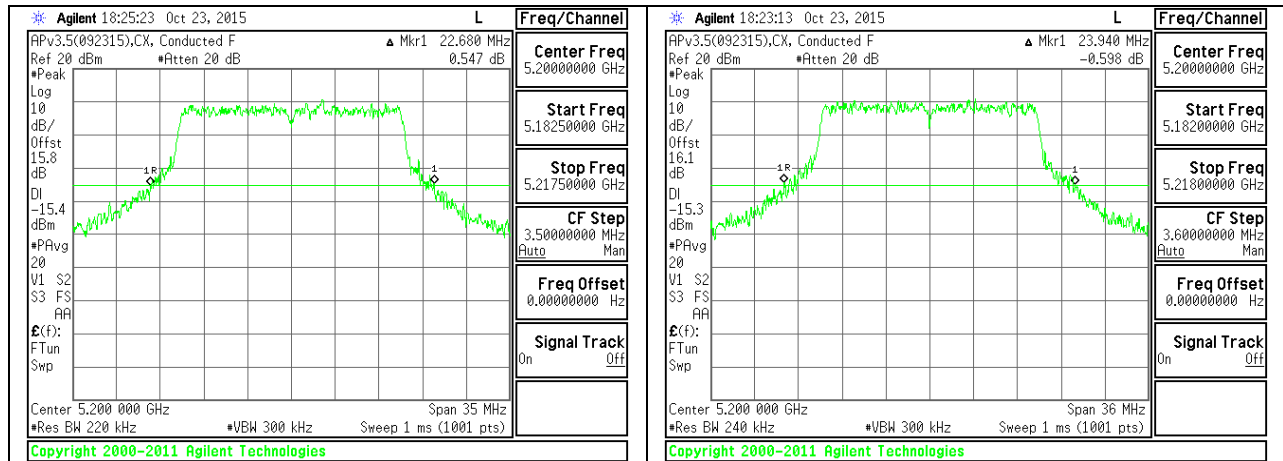

HIGH CHANNEL

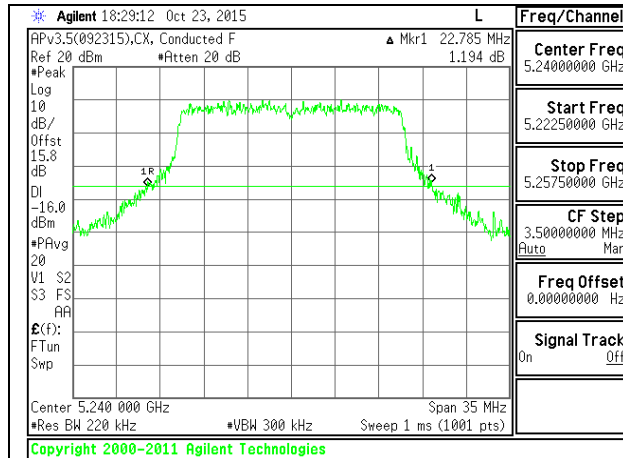

HIGH CHANNEL CHAIN 0

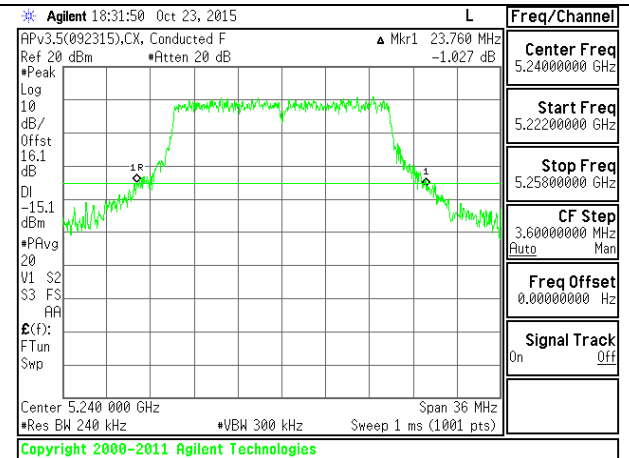

HIGH CHANNEL CHAIN 1

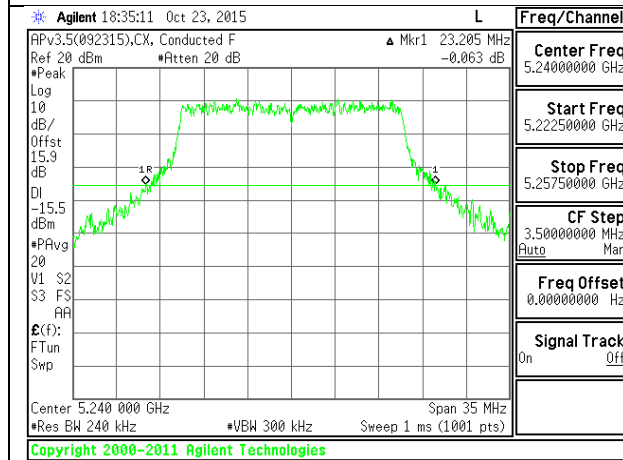

HIGH CHANNEL CHAIN 2

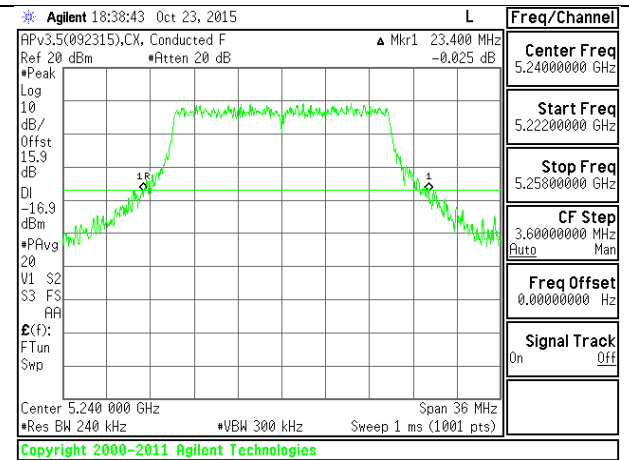

HIGH CHANNEL CHAIN 3

4.2.3. 802.11ac VHT40 MODE IN THE 5.2 GHz BAND

4Tx CDD MODE

Channel	Frequency (MHz)	26 dB Bandwidth Chain 0 (MHz)	26 dB Bandwidth Chain 1 (MHz)	26 dB Bandwidth Chain 2 (MHz)	26 dB Bandwidth Chain 3 (MHz)
Low	5190	42.624	41.958	41.106	41.895
High	5230	42.560	41.769	40.982	41.580

Test By: 39316 CX
 Test Date: 10/23/15

LOW CHANNEL

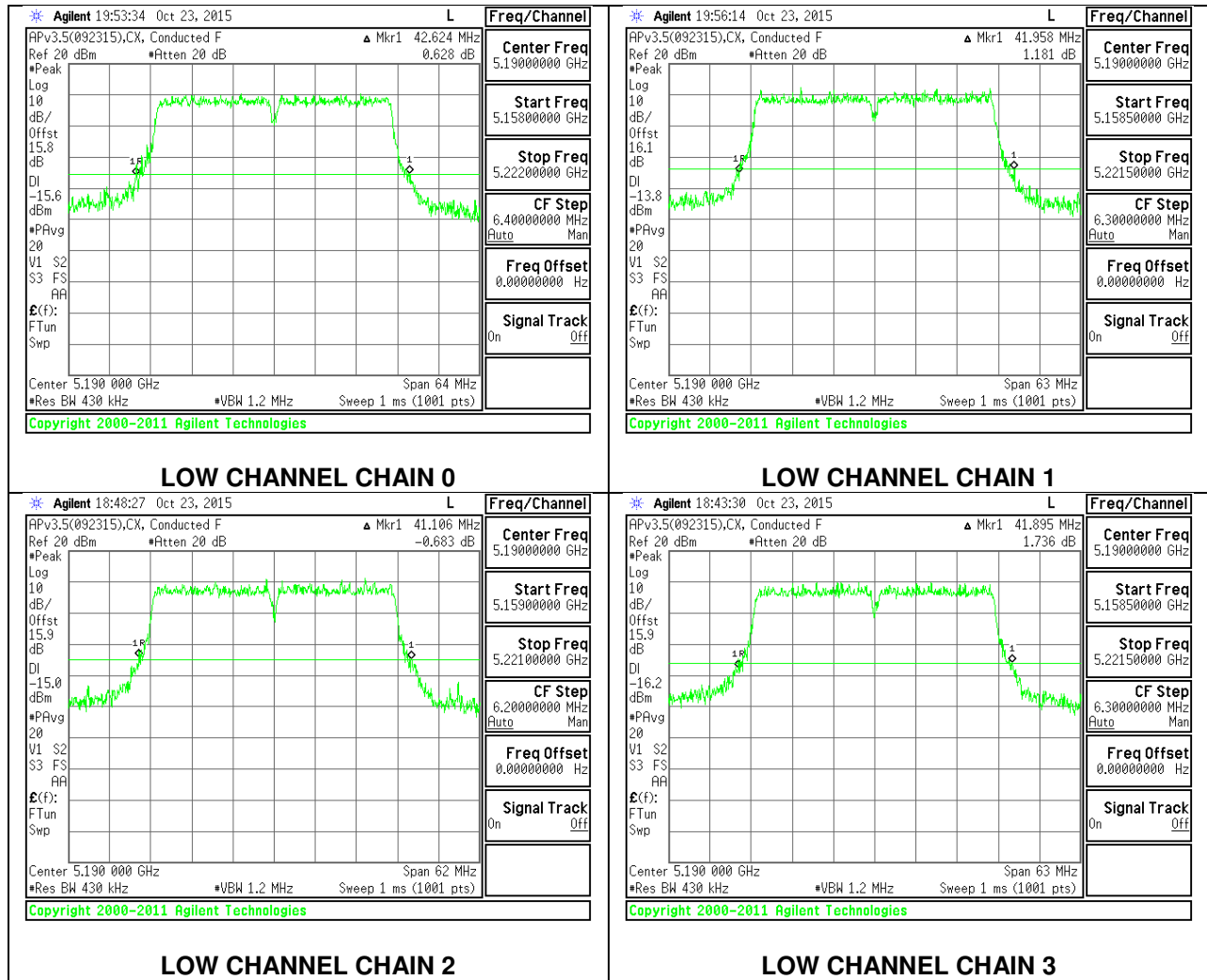

HIGH CHANNEL

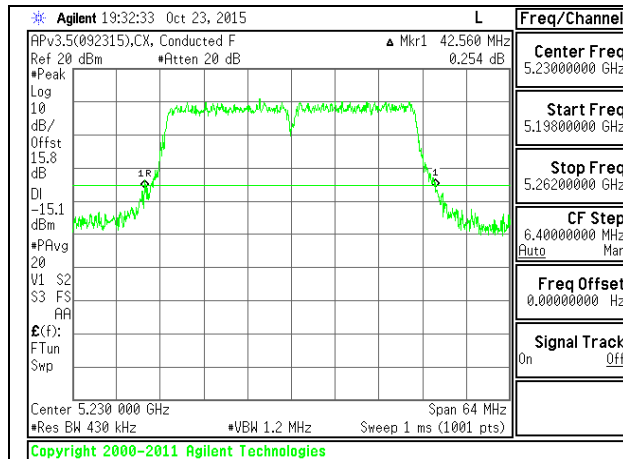

HIGH CHANNEL CHAIN 0

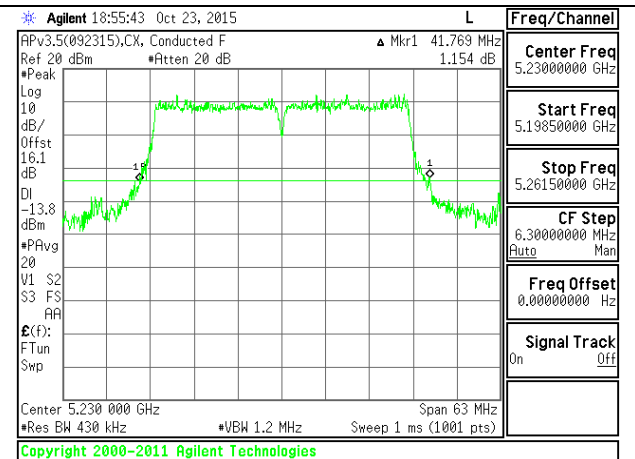

HIGH CHANNEL CHAIN 1

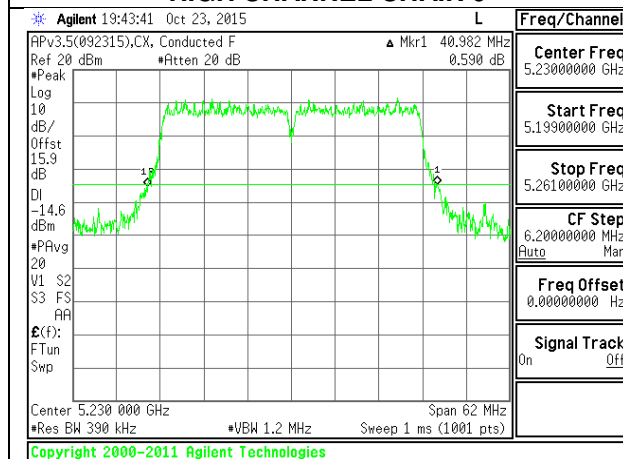

HIGH CHANNEL CHAIN 2

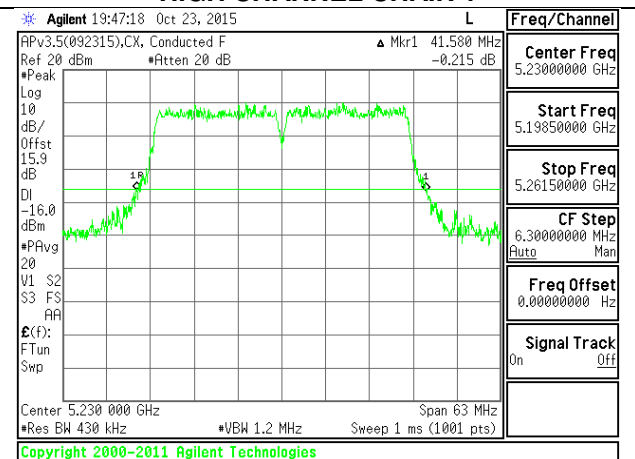

HIGH CHANNEL CHAIN 3

4.2.4. 802.11ac VHT80 MODE IN THE 5.2 GHz BAND

4Tx CDD MODE

Channel	Frequency (MHz)	26 dB Bandwidth Chain 0 (MHz)	26 dB Bandwidth Chain 1 (MHz)	26 dB Bandwidth Chain 2 (MHz)	26 dB Bandwidth Chain 3 (MHz)
Mid	5210	82.336	79.680	81.008	80.344

Test By: 39316 CX
 Test Date: 10/23/15

MID CHANNEL

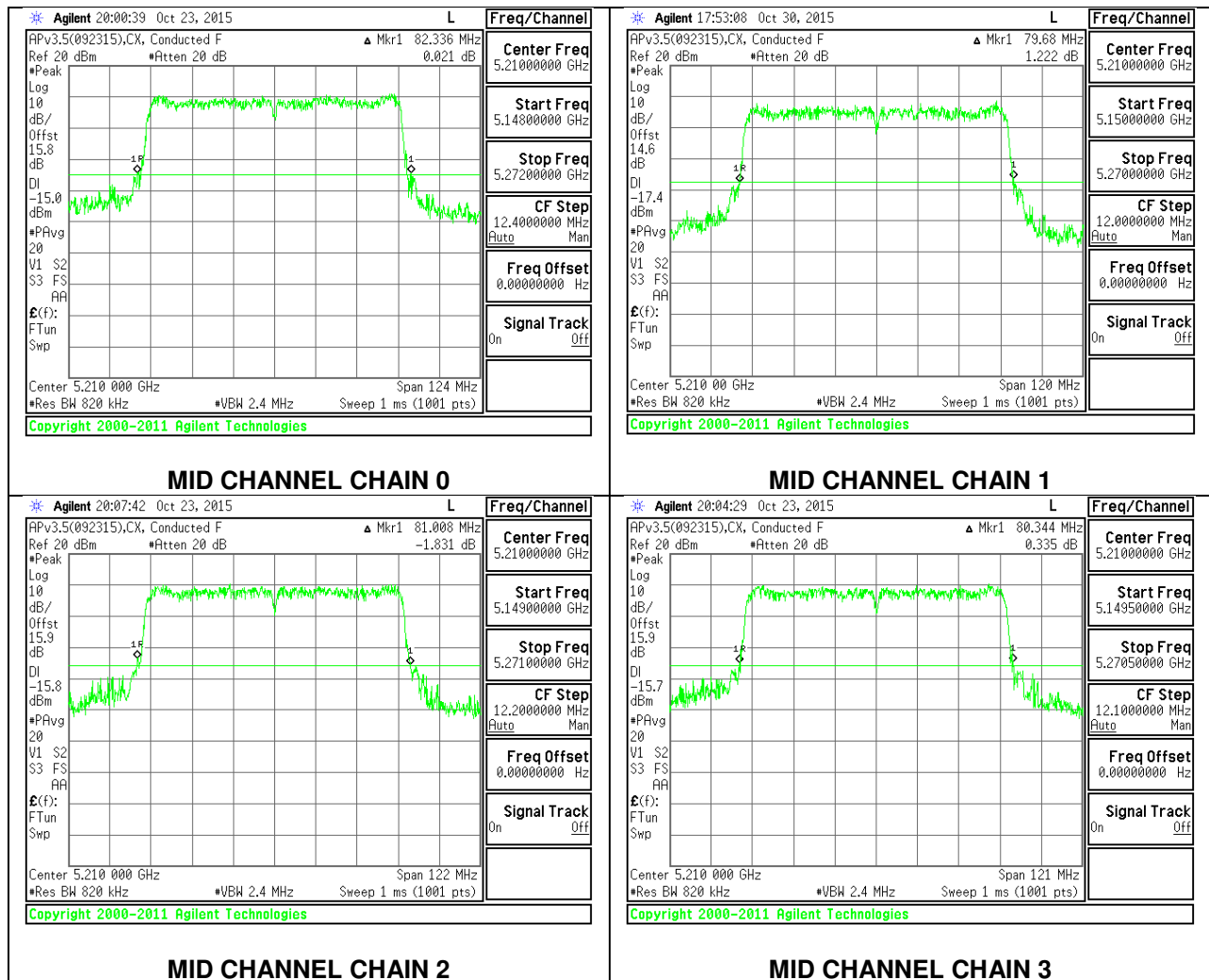

4.2.5. 802.11a MODE IN THE 5.8 GHz BAND

Channel	Frequency (MHz)	26 dB Bandwidth Chain 0 (MHz)	26 dB Bandwidth Chain 1 (MHz)	26 dB Bandwidth Chain 2 (MHz)	26 dB Bandwidth Chain 3 (MHz)
Low	5745	23.616	23.275	23.652	23.652
Mid	5785	23.065	23.616	22.820	23.868
High	5825	23.508	23.724	23.292	23.724

4Tx CDD MODE

LOW CHANNEL

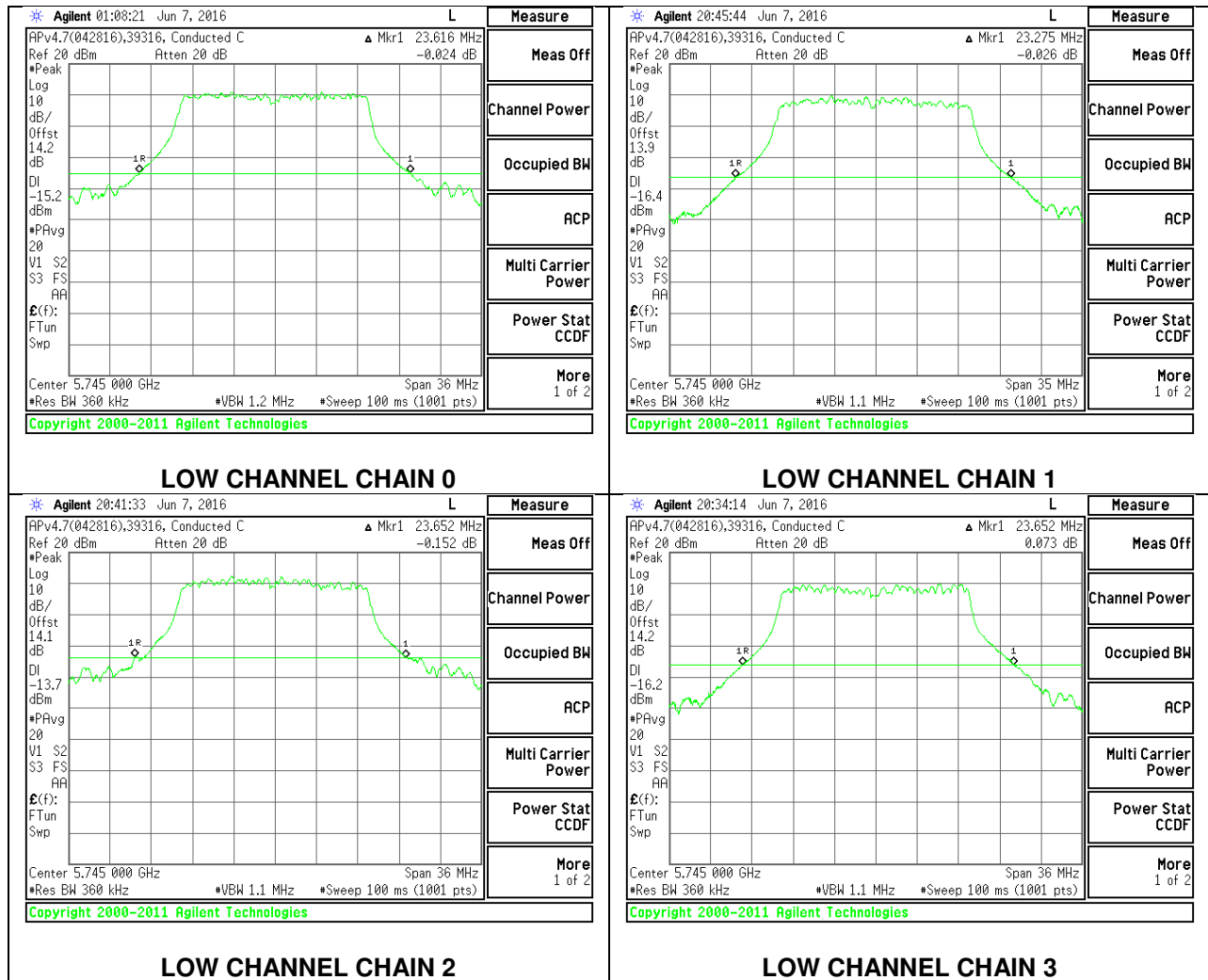

MID CHANNEL

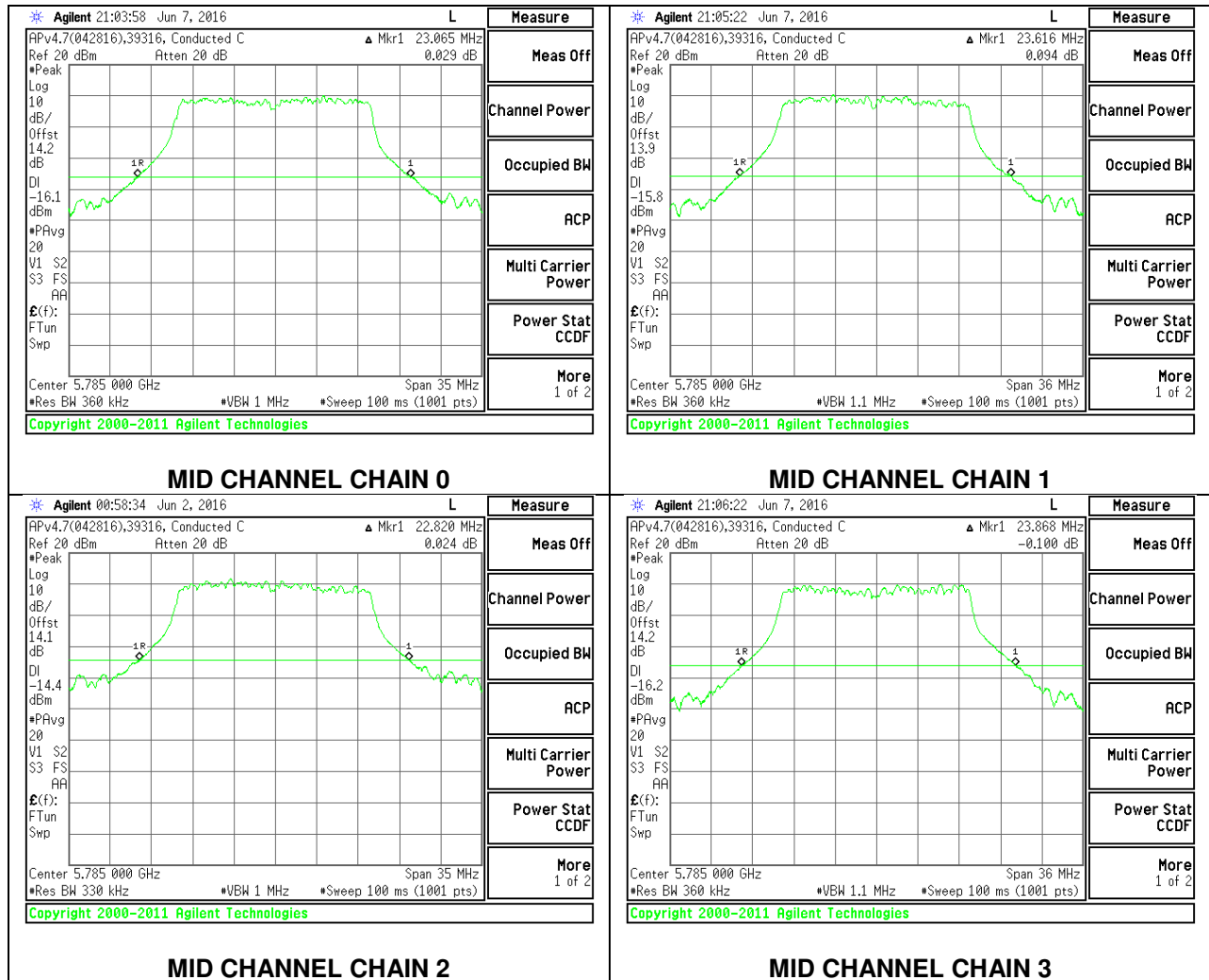

HIGH CHANNEL

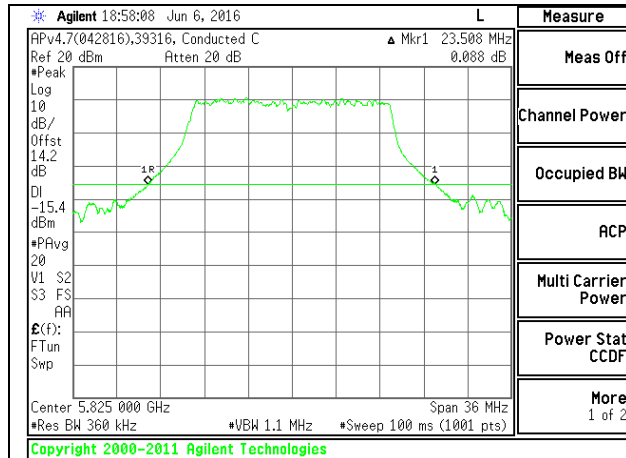

HIGH CHANNEL CHAIN 0

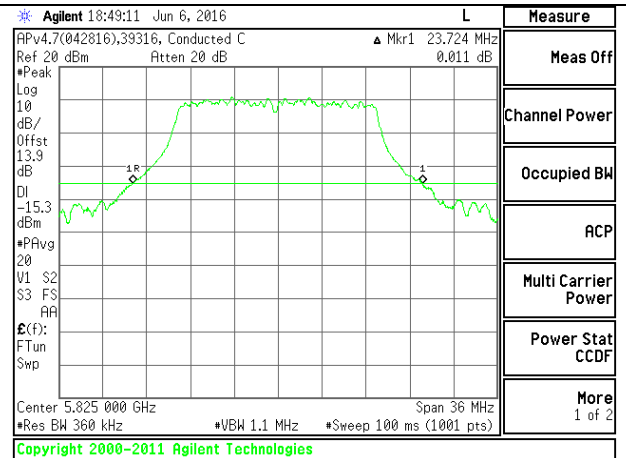

HIGH CHANNEL CHAIN 1

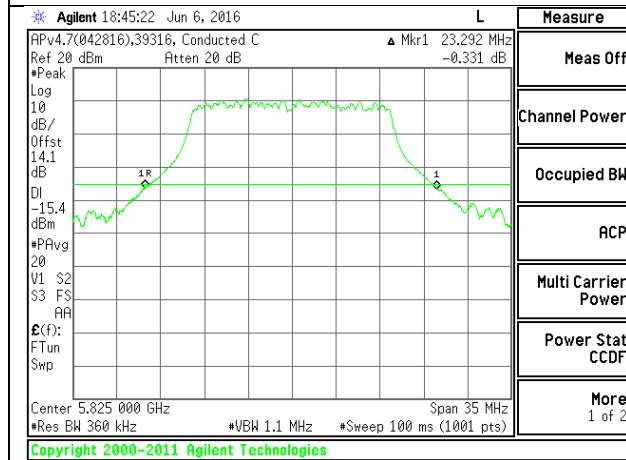

HIGH CHANNEL CHAIN 2

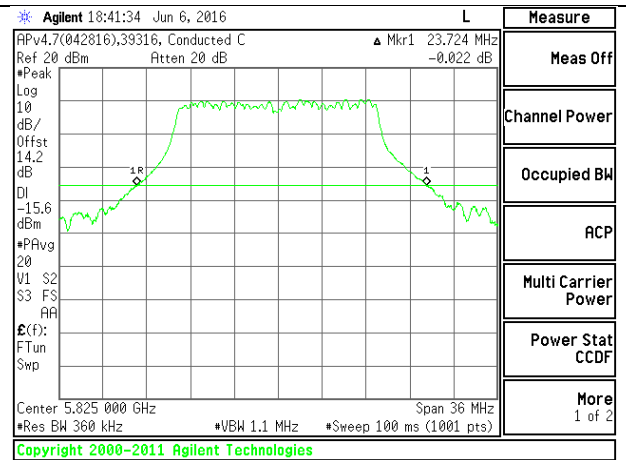

HIGH CHANNEL CHAIN 3

4.2.6. 802.11ac VHT20 MODE IN THE 5.8 GHz BAND

4 Tx CDD MODE

Channel	Frequency (MHz)	26 dB Bandwidth Chain 0 (MHz)	26 dB Bandwidth Chain 1 (MHz)	26 dB Bandwidth Chain 2 (MHz)	26 dB Bandwidth Chain 3 (MHz)
Low	5745	23.135	22.168	22.270	22.680
Mid	5785	22.474	23.170	22.372	23.310
High	5825	22.474	22.680	22.168	23.508

Test By: 37699 CS
 Test Date: 10/27/15

LOW CHANNEL

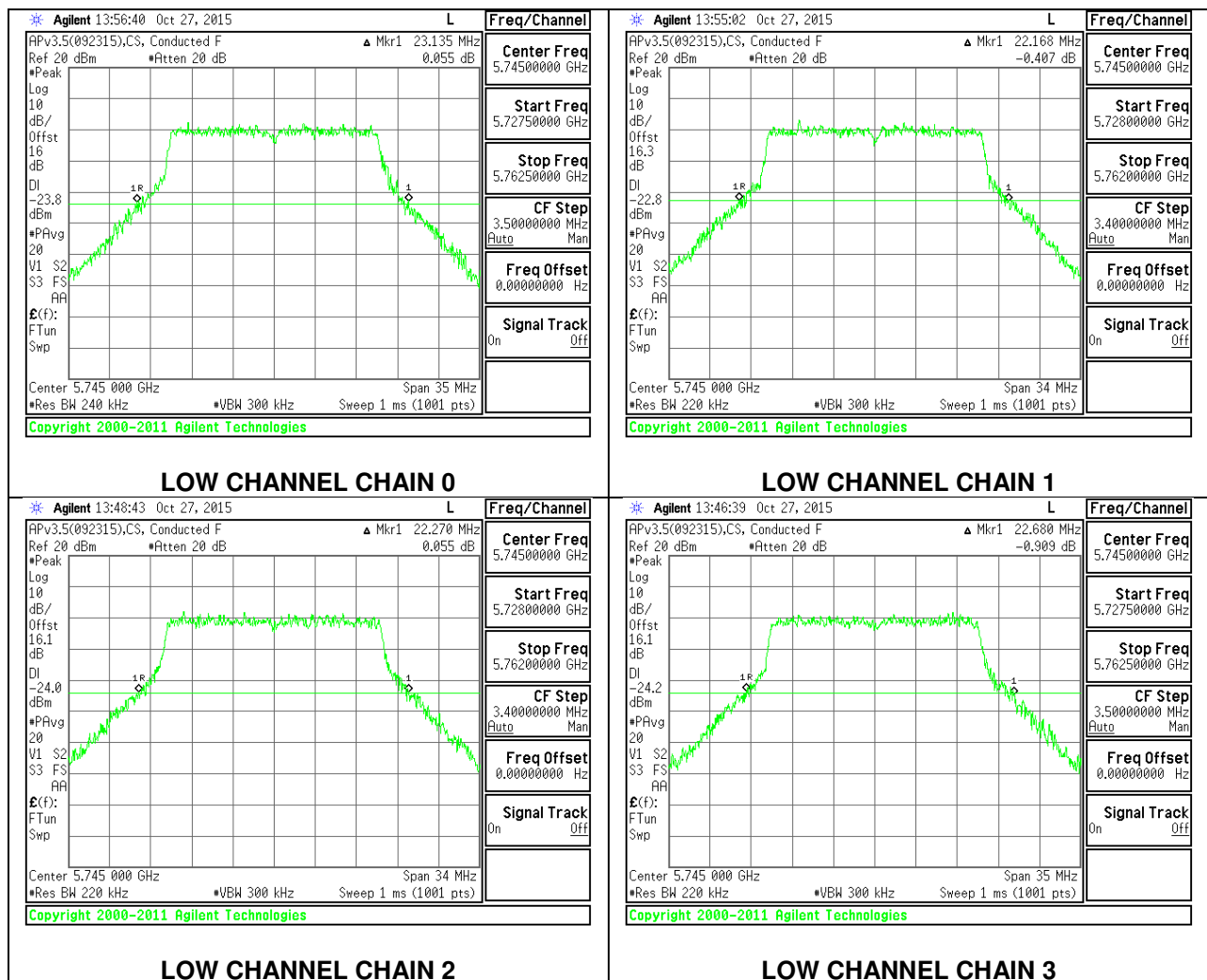

MID CHANNEL

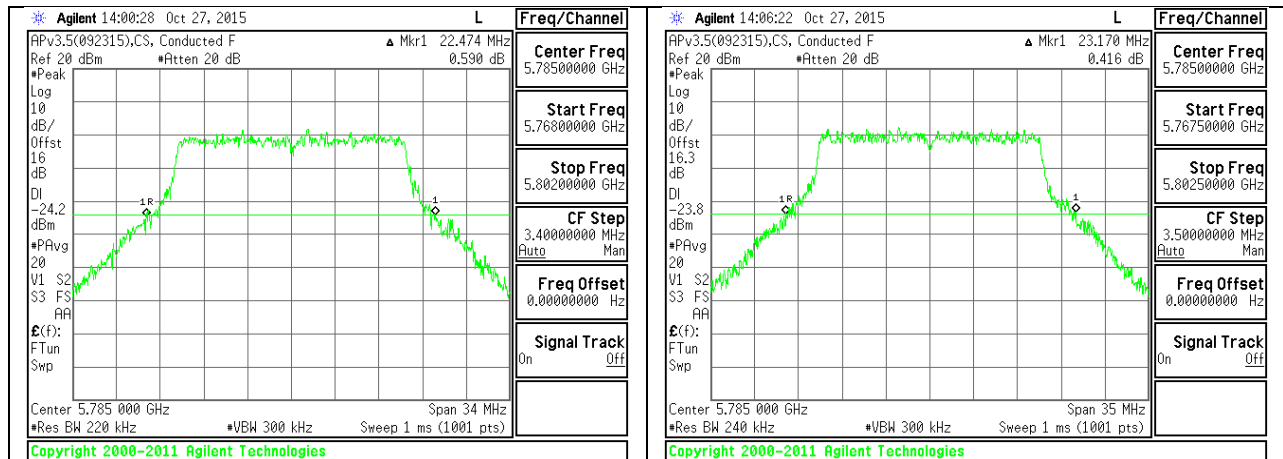

MID CHANNEL CHAIN 0

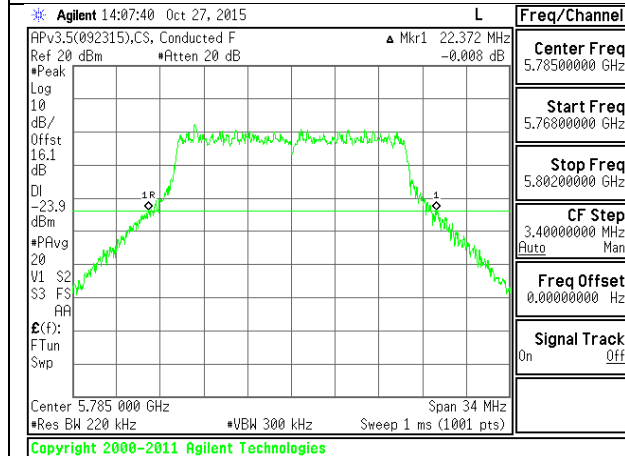

MID CHANNEL CHAIN 2

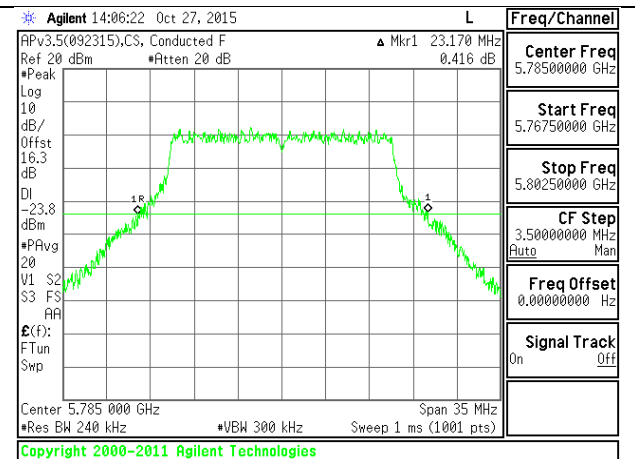

MID CHANNEL CHAIN 1

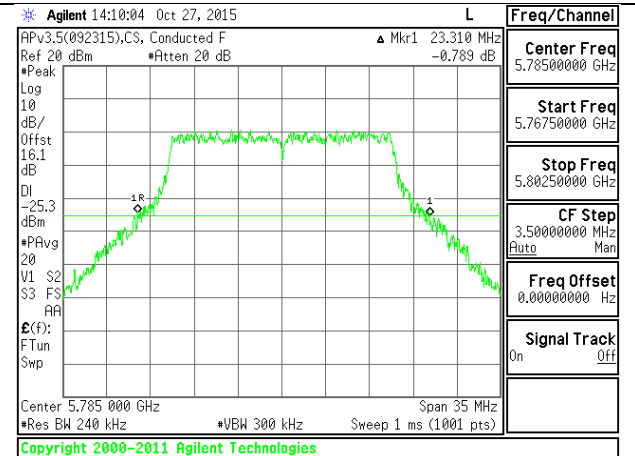

MID CHANNEL CHAIN 3

HIGH CHANNEL

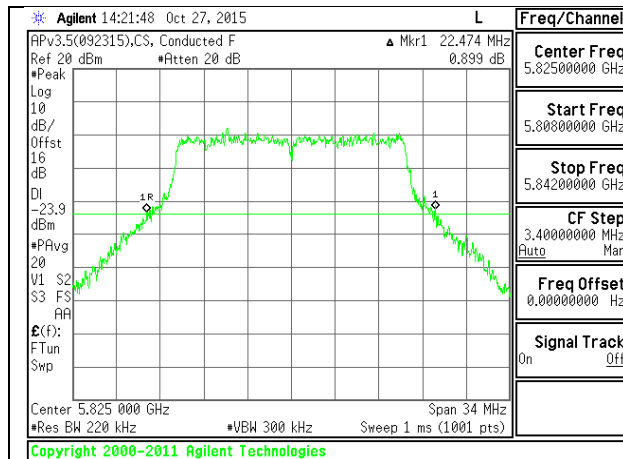

HIGH CHANNEL CHAIN 0

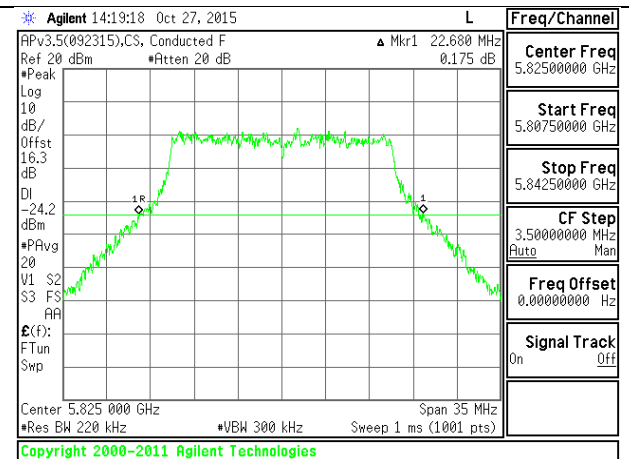

HIGH CHANNEL CHAIN 1

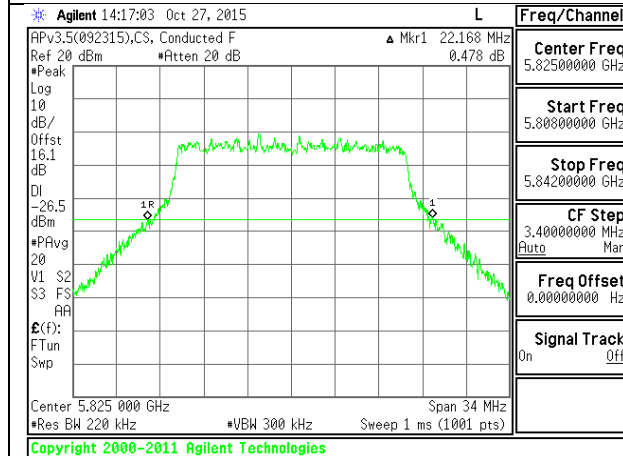

HIGH CHANNEL CHAIN 2

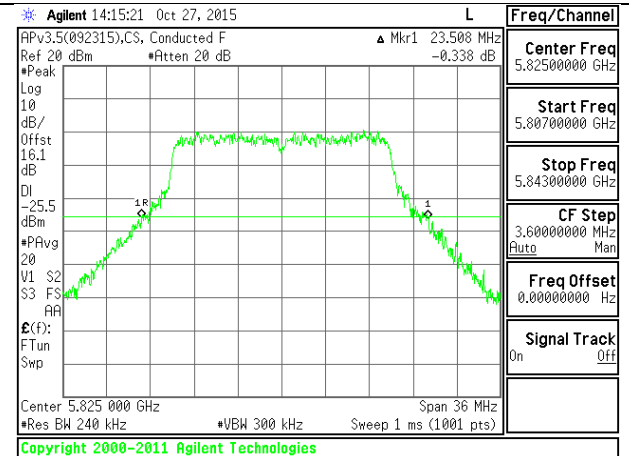

HIGH CHANNEL CHAIN 3

4.2.7. 802.11ac VHT40 MODE IN THE 5.8 GHz BAND

4 Tx CDD MODE

Channel	Frequency (MHz)	26 dB Bandwidth Chain 0 (MHz)	26 dB Bandwidth Chain 1 (MHz)	26 dB Bandwidth Chain 2 (MHz)	26 dB Bandwidth Chain 3 (MHz)
Low	5755	41.958	41.454	40.734	40.796
High	5795	41.454	41.391	41.044	40.920

Test By: 37699 CS
 Test Date: 10/27/15

LOW CHANNEL

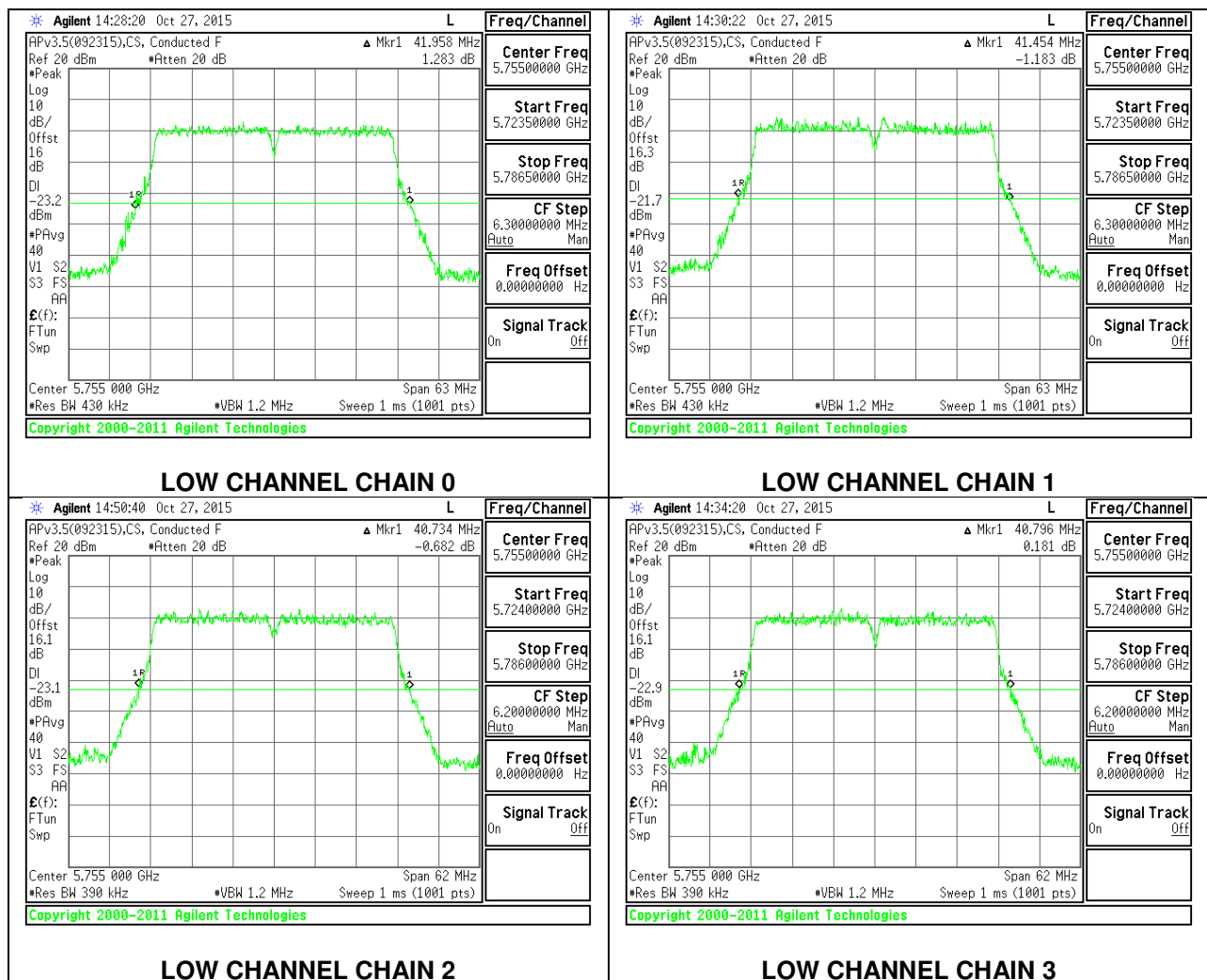

HIGH CHANNEL

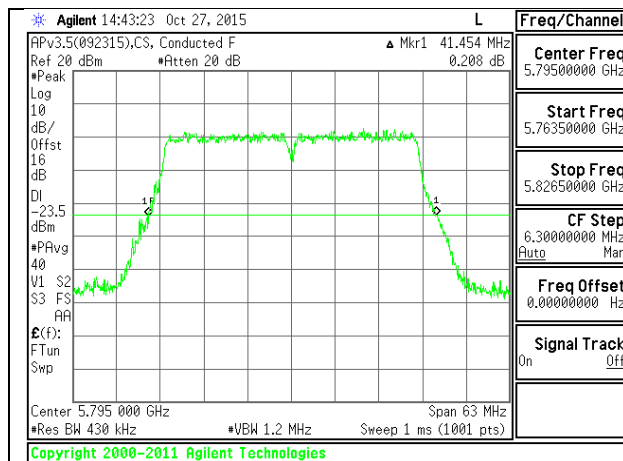

HIGH CHANNEL CHAIN 0

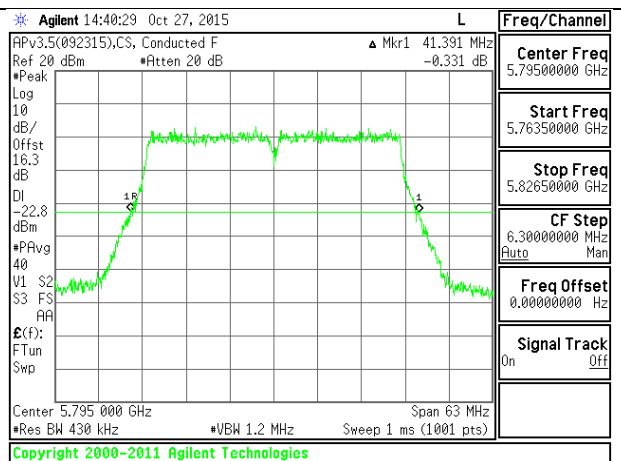

HIGH CHANNEL CHAIN 1

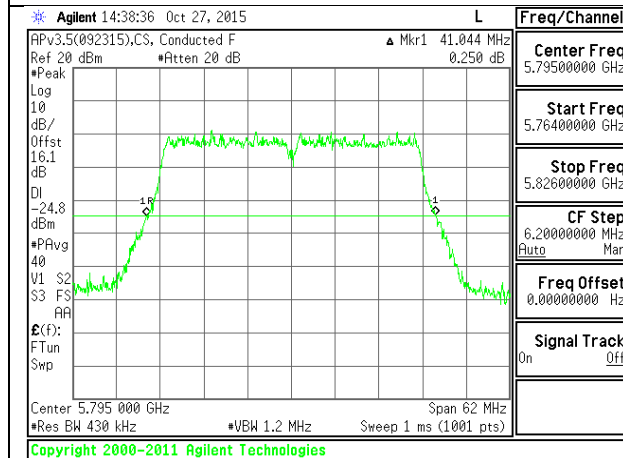

HIGH CHANNEL CHAIN 2

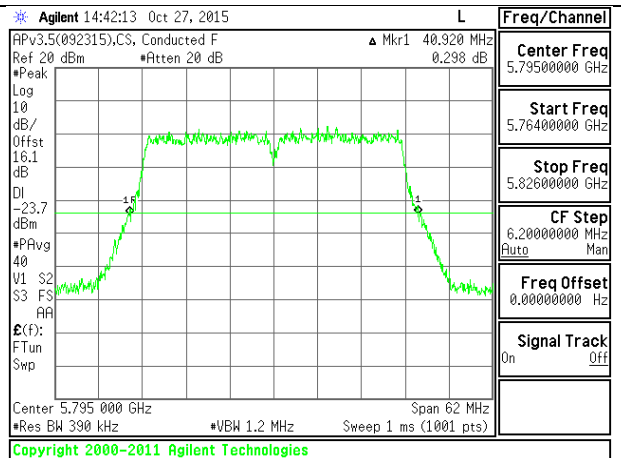

HIGH CHANNEL CHAIN 3

4.2.8. 802.11ac VHT80 MODE IN THE 5.8 GHz BAND

4 Tx CDD MODE

Channel	Frequency (MHz)	26 dB Bandwidth Chain 0 (MHz)	26 dB Bandwidth Chain 1 (MHz)	26 dB Bandwidth Chain 2 (MHz)	26 dB Bandwidth Chain 3 (MHz)
Mid	5775	82.460	80.102	81.549	80.586

Test By: 37699 CS
 Test Date: 10/27/15

MID CHANNEL

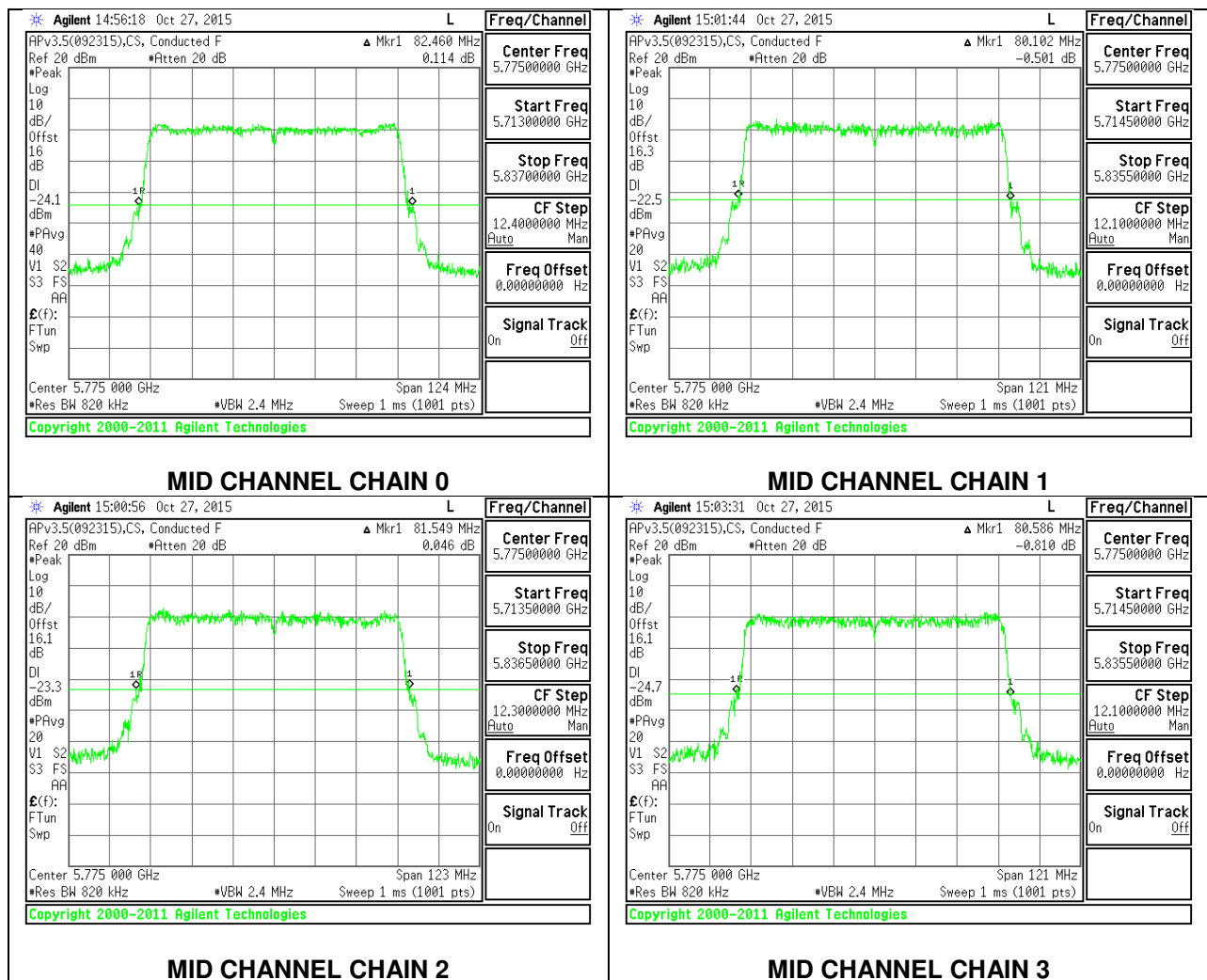

4.3. 99% BANDWIDTH

LIMITS

None; for reporting purposes only.

RESULTS

4.3.1. 802.11a MODE IN THE 5.2 GHz BAND

4 Tx CDD MODE

Channel	Frequency (MHz)	99% Bandwidth Chain 0 (MHz)	99% Bandwidth Chain 1 (MHz)	99% Bandwidth Chain 2 (MHz)	99% Bandwidth Chain 3 (MHz)
Low	5180	16.662	16.852	16.367	16.951
Mid	5200	16.715	16.840	16.836	16.771
High	5240	16.771	16.756	16.883	16.807

LOW CHANNEL

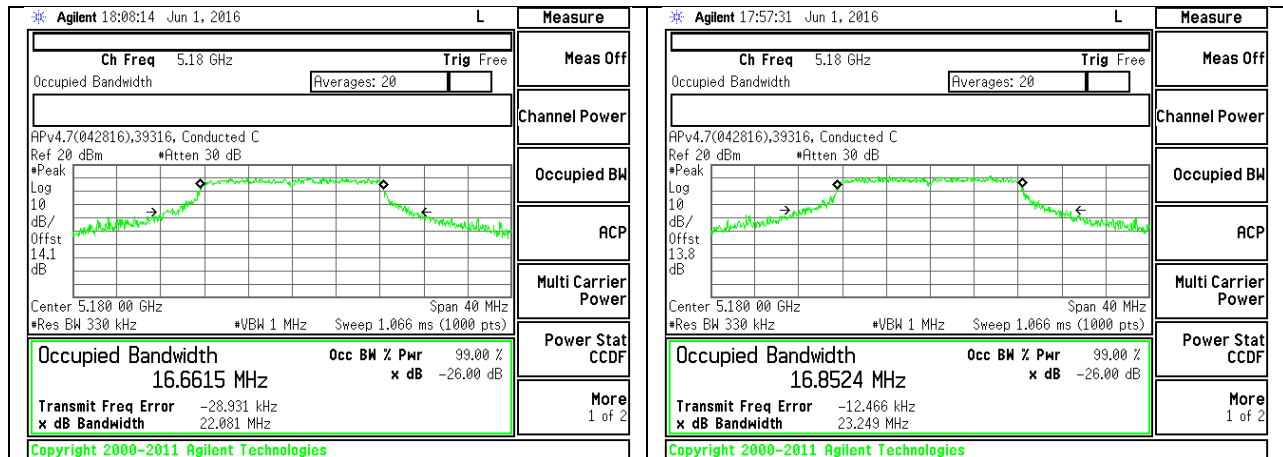

LOW CHANNEL CHAIN 0

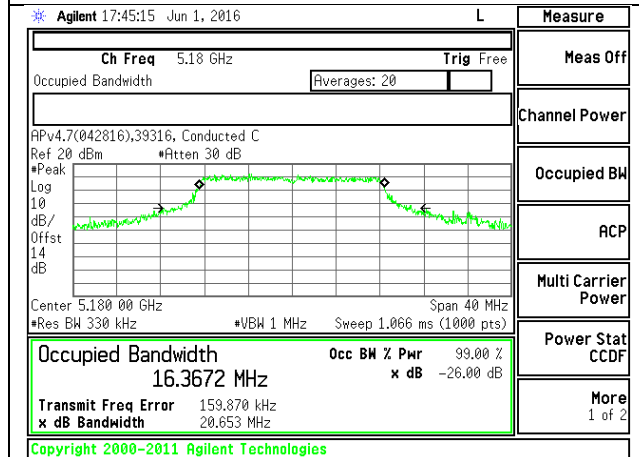

LOW CHANNEL CHAIN 2

LOW CHANNEL CHAIN 1

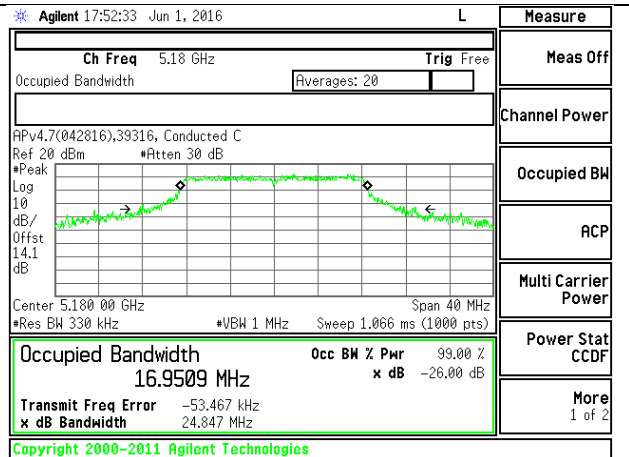

LOW CHANNEL CHAIN 3

MID CHANNEL

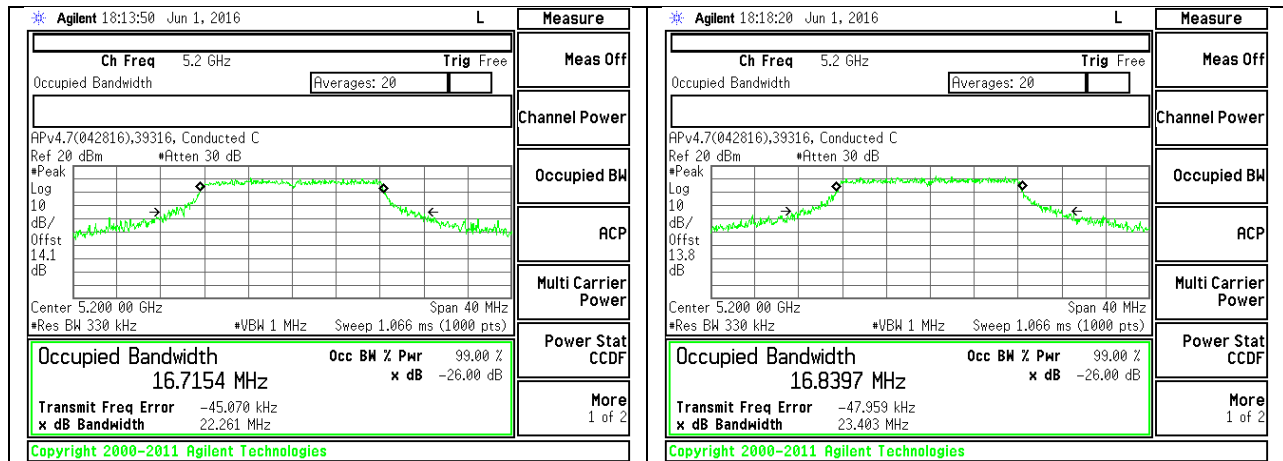

MID CHANNEL CHAIN 0

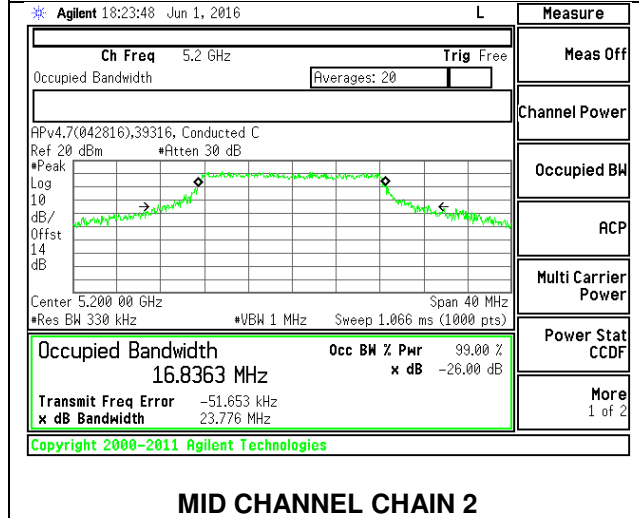

MID CHANNEL CHAIN 1

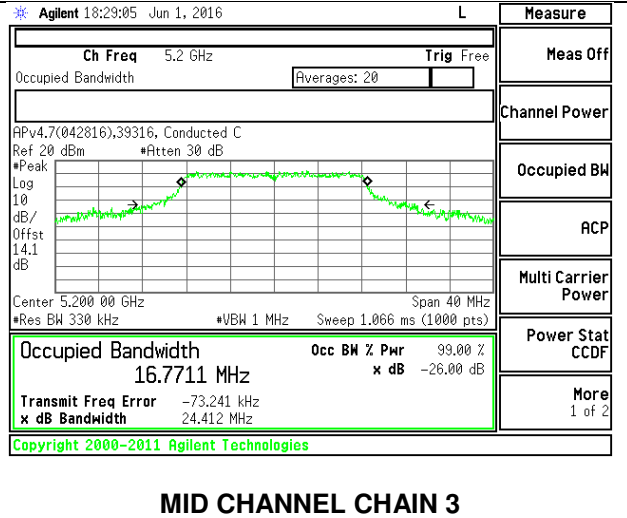

HIGH CHANNEL

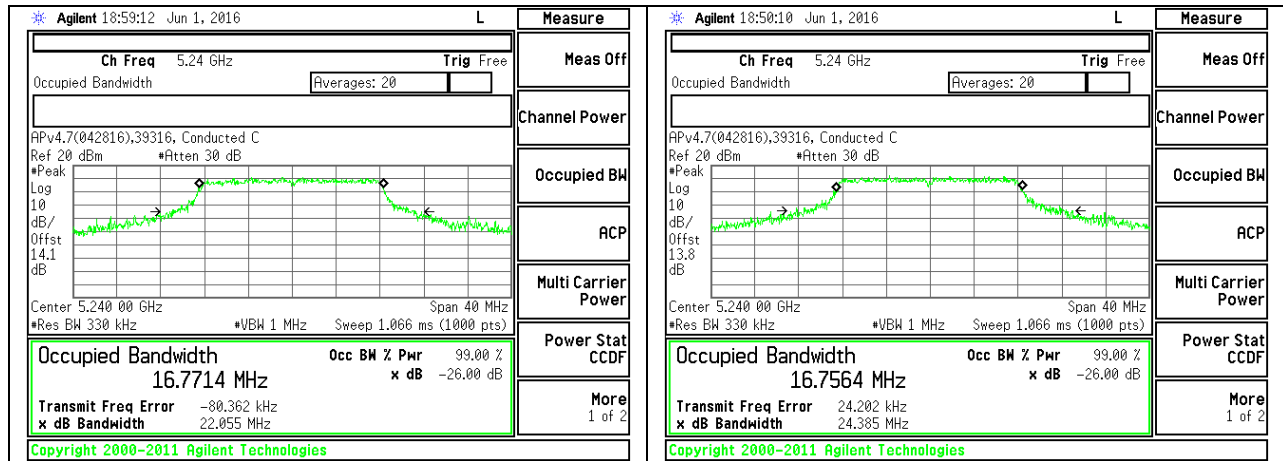

HIGH CHANNEL CHAIN 0

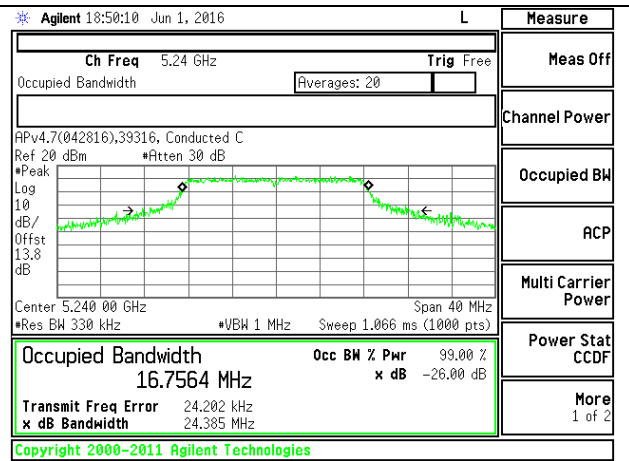

HIGH CHANNEL CHAIN 1

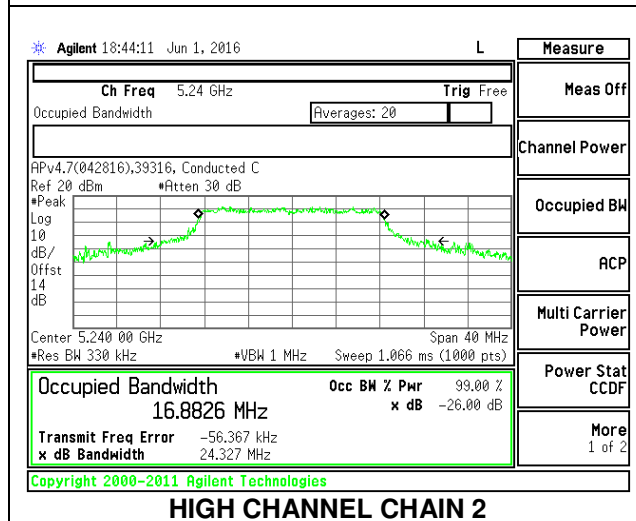

HIGH CHANNEL CHAIN 2

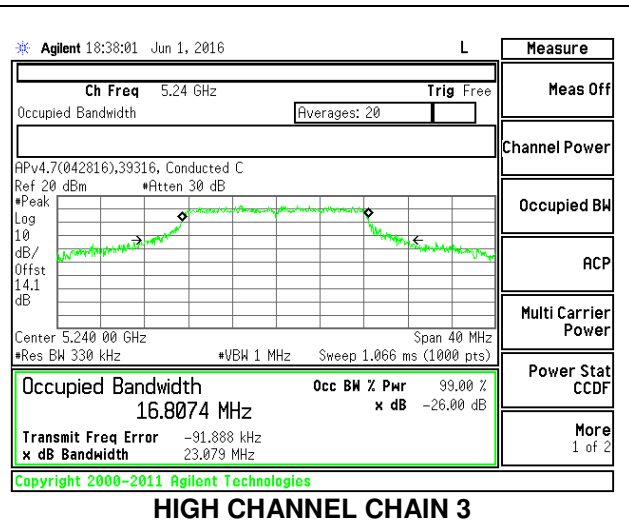

HIGH CHANNEL CHAIN 3

4.3.2. 802.11ac VHT20 MODE IN THE 5.2 GHz BAND

4 Tx CDD MODE

Channel	Frequency (MHz)	99% Bandwidth Chain 0 (MHz)	99% Bandwidth Chain 1 (MHz)	99% Bandwidth Chain 2 (MHz)	99% Bandwidth Chain 3 (MHz)
Low	5180	17.702	17.532	17.621	17.639
Mid	5200	17.567	17.785	17.708	17.479
High	5240	17.767	17.708	17.701	17.829

Test By: 39316 CX
 Test Date: 10/23/15

LOW CHANNEL

LOW CHANNEL CHAIN 0

Occupied Bandwidth: 17.7015 MHz
 Occ BN % Pwr: 99.00 % x dB -26.00 dB
 Transmit Freq Error: 39.302 kHz
 x dB Bandwidth: 23.005 MHz*

LOW CHANNEL CHAIN 1

Occupied Bandwidth: 17.5315 MHz
 Occ BN % Pwr: 99.00 % x dB -26.00 dB
 Transmit Freq Error: -85.684 kHz
 x dB Bandwidth: 22.355 MHz*

LOW CHANNEL CHAIN 2

Occupied Bandwidth: 17.6207 MHz
 Occ BN % Pwr: 99.00 % x dB -26.00 dB
 Transmit Freq Error: -97.596 kHz
 x dB Bandwidth: 21.978 MHz*

LOW CHANNEL CHAIN 3

Occupied Bandwidth: 17.6393 MHz
 Occ BN % Pwr: 99.00 % x dB -26.00 dB
 Transmit Freq Error: -115.847 kHz
 x dB Bandwidth: 22.735 MHz*

MID CHANNEL

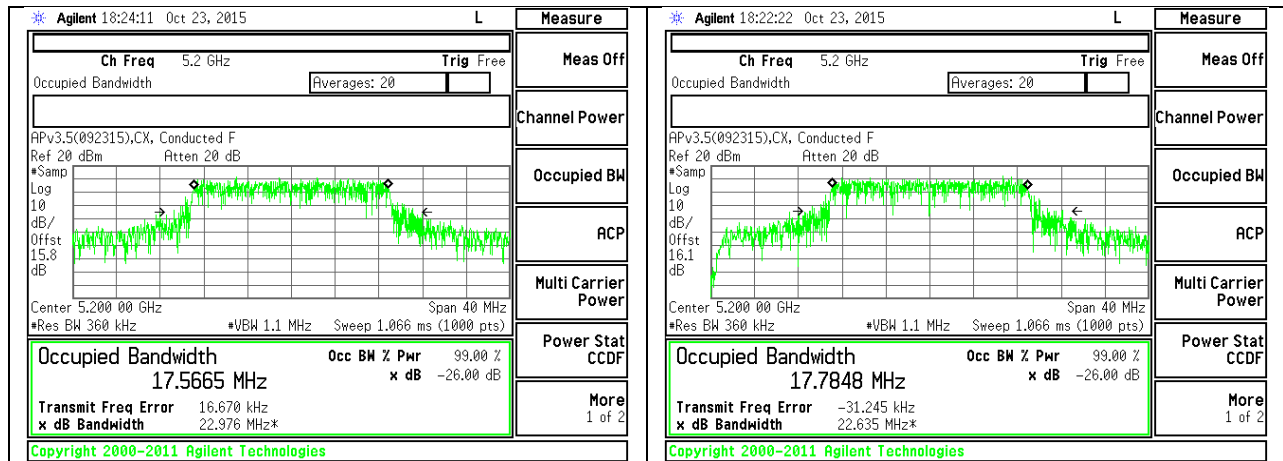

MID CHANNEL CHAIN 0

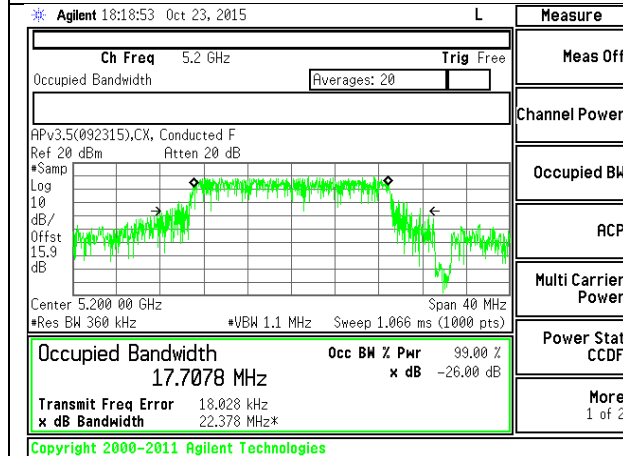

MID CHANNEL CHAIN 2

MID CHANNEL CHAIN 1

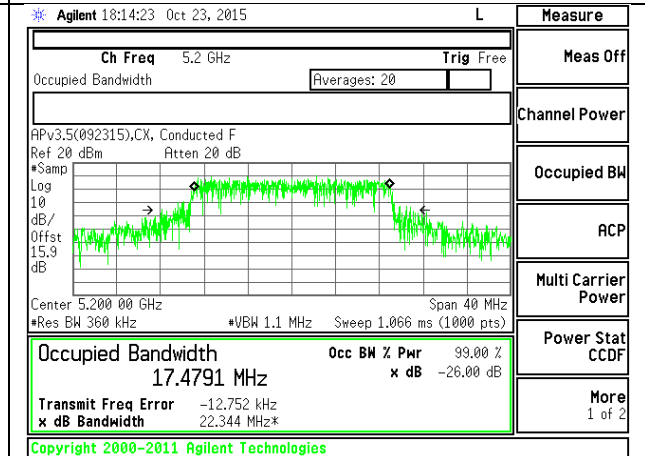

MID CHANNEL CHAIN 3

HIGH CHANNEL

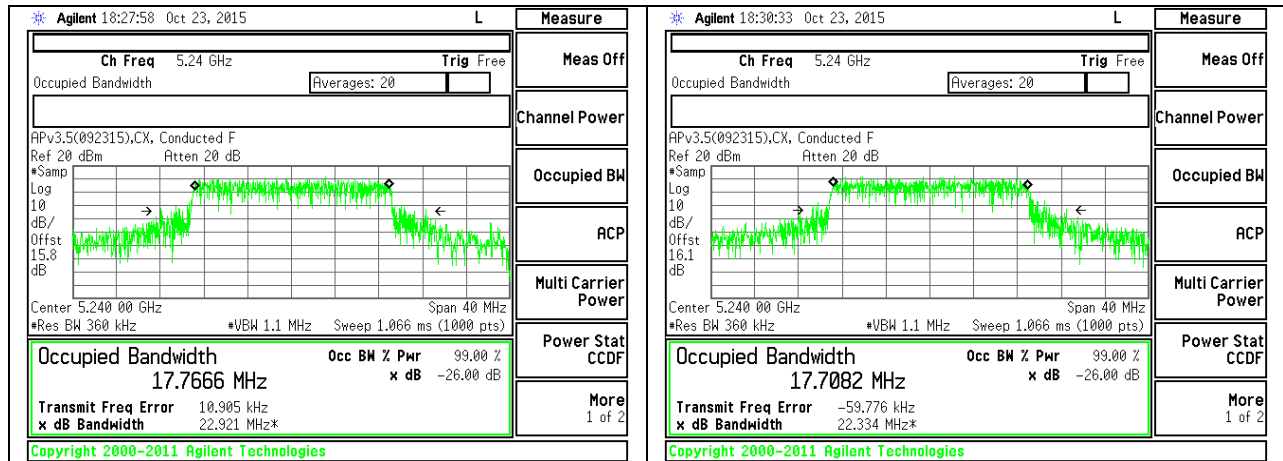

HIGH CHANNEL CHAIN 0

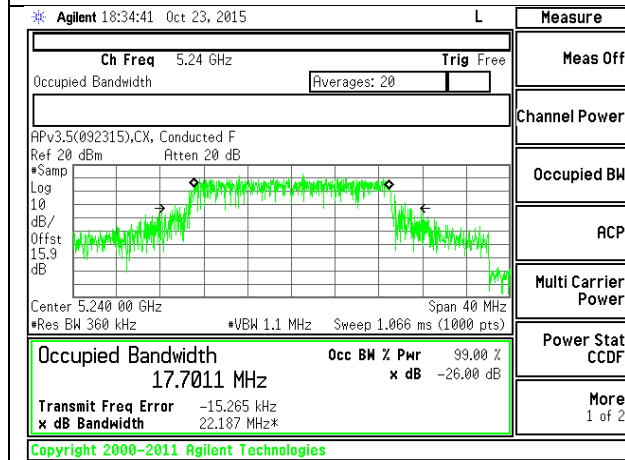

HIGH CHANNEL CHAIN 2

HIGH CHANNEL CHAIN 1

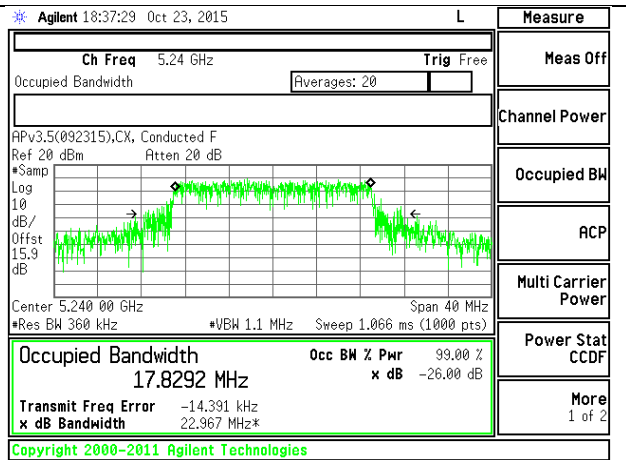

HIGH CHANNEL CHAIN 3

4.3.3. 802.11ac VHT40 MODE IN THE 5.2 GHz BAND

4 Tx CDD MODE

Channel	Frequency (MHz)	99% Bandwidth Chain 0 (MHz)	99% Bandwidth Chain 1 (MHz)	99% Bandwidth Chain 2 (MHz)	99% Bandwidth Chain 3 (MHz)
Low	5190	36.546	36.531	36.513	36.453
High	5230	36.609	36.330	36.577	36.423

Test By: 39316 CX
 Test Date: 10/23/15

LOW CHANNEL

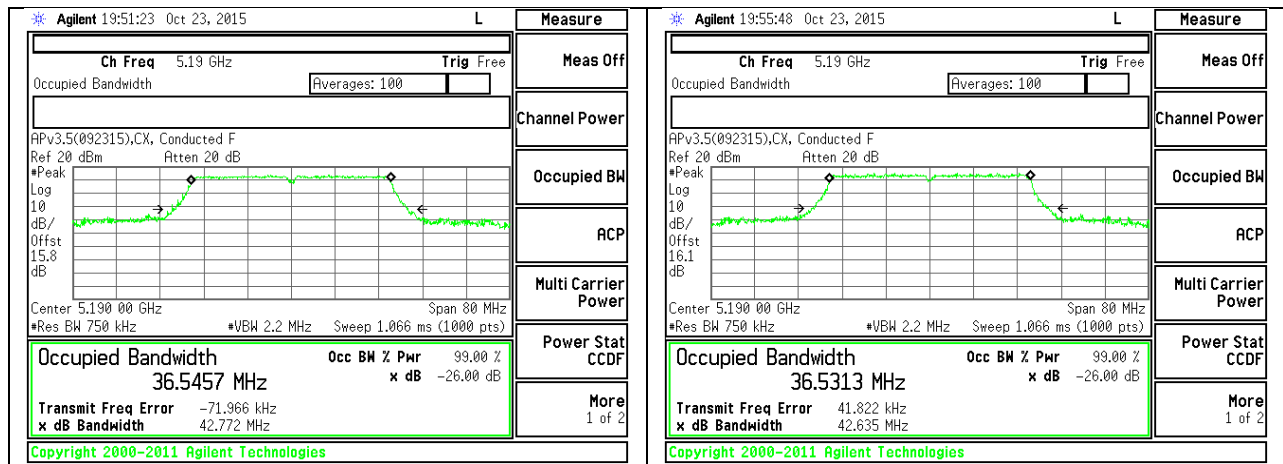

LOW CHANNEL CHAIN 0

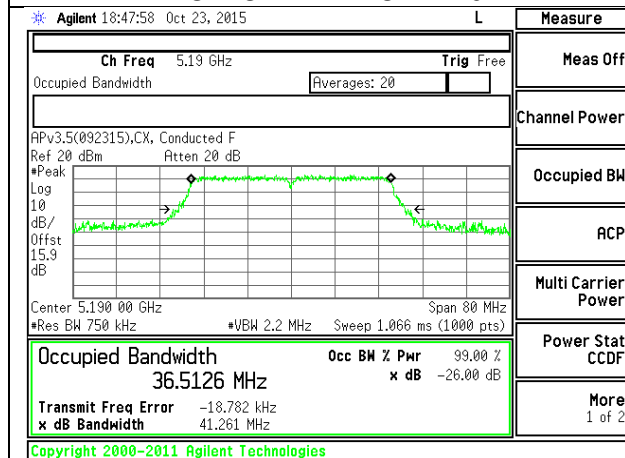

LOW CHANNEL CHAIN 2

LOW CHANNEL CHAIN 1

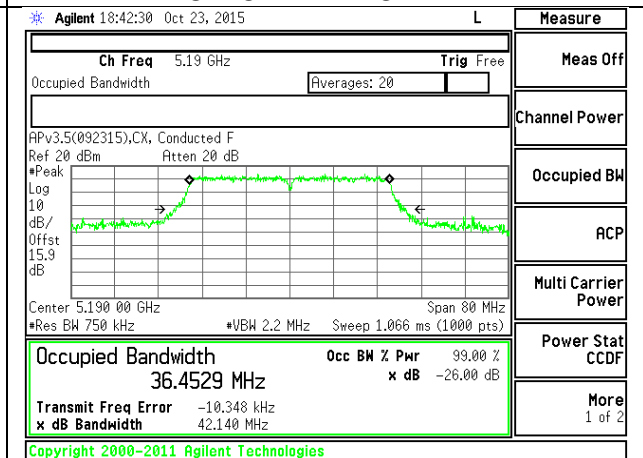

LOW CHANNEL CHAIN 3

HIGH CHANNEL

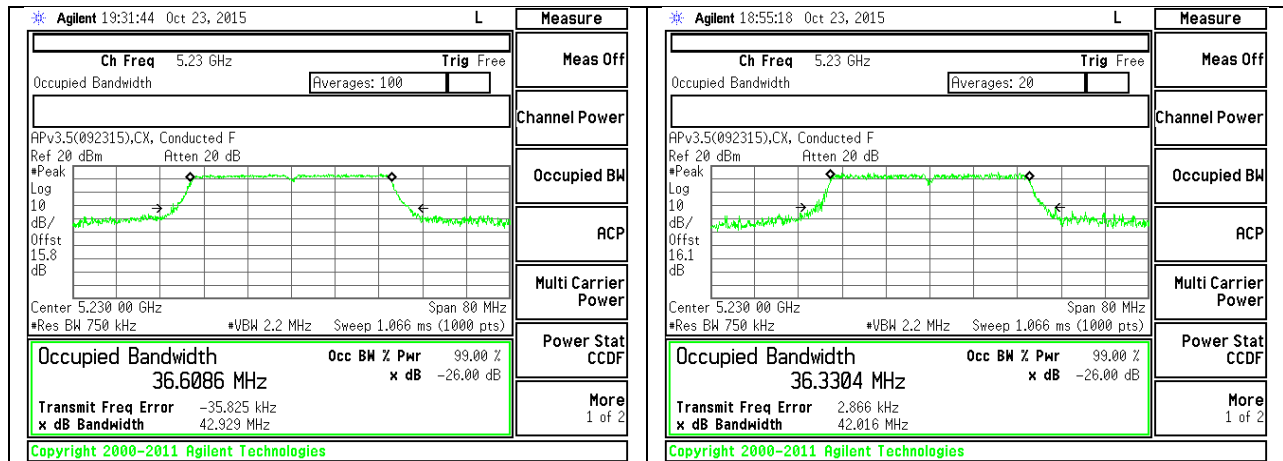

HIGH CHANNEL CHAIN 0

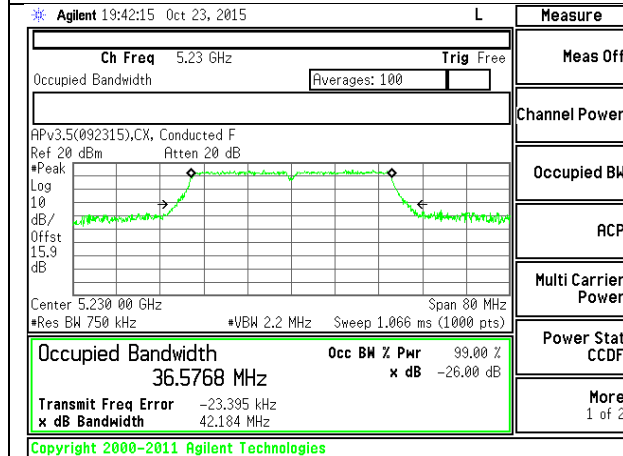

HIGH CHANNEL CHAIN 2

HIGH CHANNEL CHAIN 1

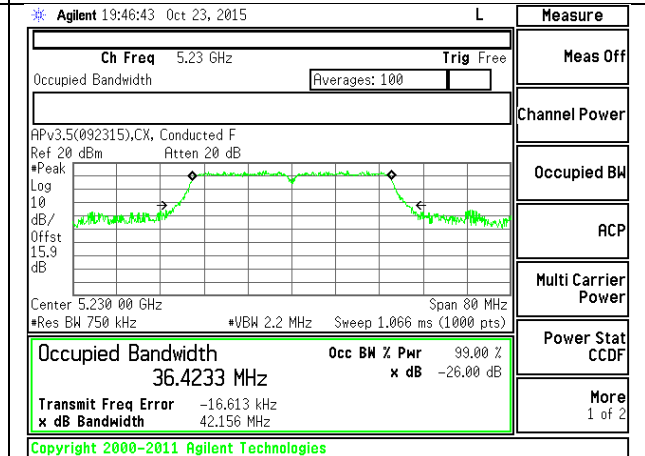

HIGH CHANNEL CHAIN 3

4.3.4. 802.11ac VHT80 MODE IN THE 5.2 GHz BAND

4 Tx CDD MODE

Channel	Frequency (MHz)	99% Bandwidth Chain 0 (MHz)	99% Bandwidth Chain 1 (MHz)	99% Bandwidth Chain 2 (MHz)	99% Bandwidth Chain 3 (MHz)
Mid	5210	75.489	75.540	75.443	75.516

MID CHANNEL

Test By: 39316 CX
 Test Date: 10/23/15

MID CHANNEL CHAIN 0

Agilent 19:59:02 Oct 23, 2015

Ch Freq 5.21 GHz

Occupied Bandwidth 75.4892 MHz

Transmit Freq Error -20.615 kHz

x dB Bandwidth 84.339 MHz

MID CHANNEL CHAIN 1

Agilent 20:01:27 Oct 23, 2015

Ch Freq 5.21 GHz

Occupied Bandwidth 75.5404 MHz

Transmit Freq Error -80.632 kHz

x dB Bandwidth 84.712 MHz

MID CHANNEL CHAIN 2

Agilent 20:06:34 Oct 23, 2015

Ch Freq 5.21 GHz

Occupied Bandwidth 75.4427 MHz

Transmit Freq Error 6.131 kHz

x dB Bandwidth 82.945 MHz

MID CHANNEL CHAIN 3

Agilent 20:03:33 Oct 23, 2015

Ch Freq 5.21 GHz

Occupied Bandwidth 75.5157 MHz

Transmit Freq Error 6.095 kHz

x dB Bandwidth 81.942 MHz

4.3.5. 802.11a MODE IN THE 5.8 GHz BAND

4 Tx CDD MODE

Channel	Frequency (MHz)	99% Bandwidth Chain 0 (MHz)	99% Bandwidth Chain 1 (MHz)	99% Bandwidth Chain 2 (MHz)	99% Bandwidth Chain 3 (MHz)
Low	5745	16.905	16.679	16.724	16.973
Mid	5785	16.821	16.639	16.633	16.912
High	5825	16.768	16.717	16.828	16.843

LOW CHANNEL

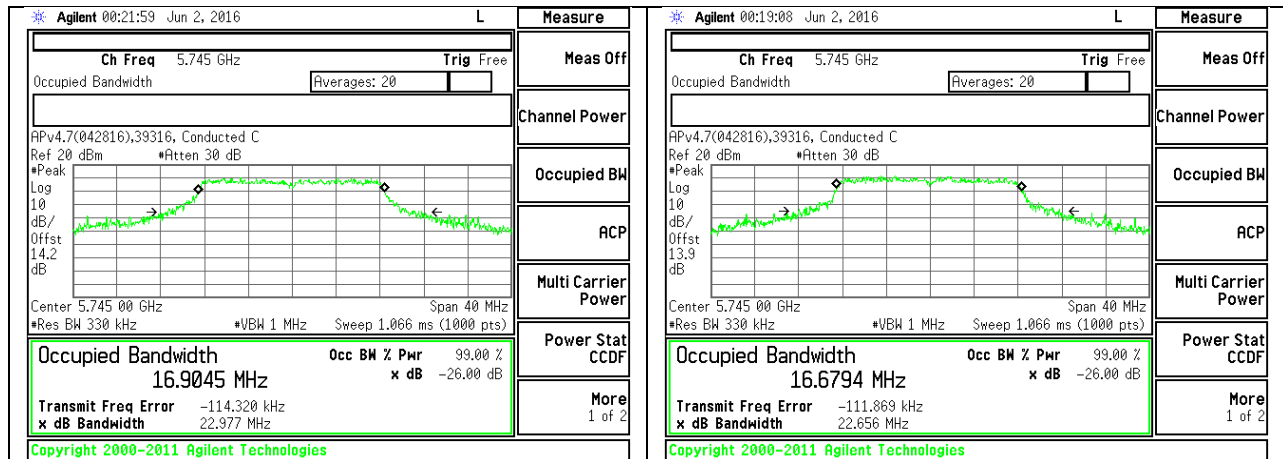

LOW CHANNEL CHAIN 0

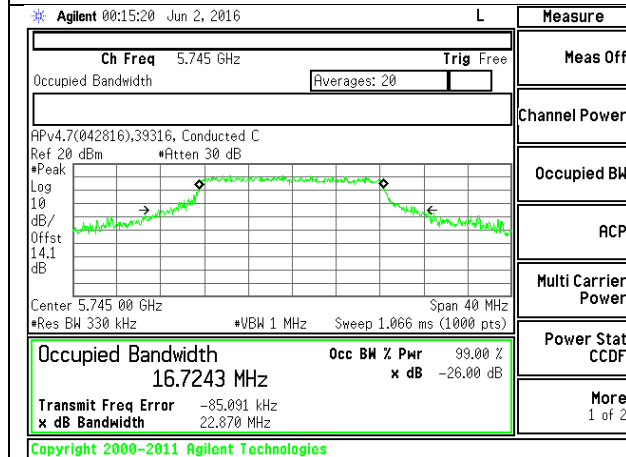

LOW CHANNEL CHAIN 1

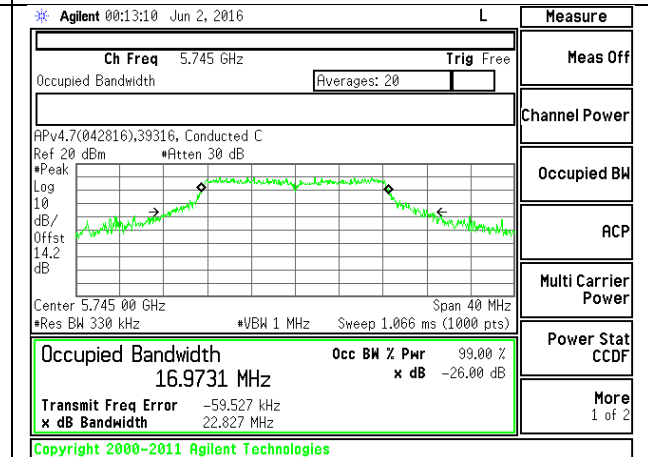

LOW CHANNEL CHAIN 2

LOW CHANNEL CHAIN 3

MID CHANNEL

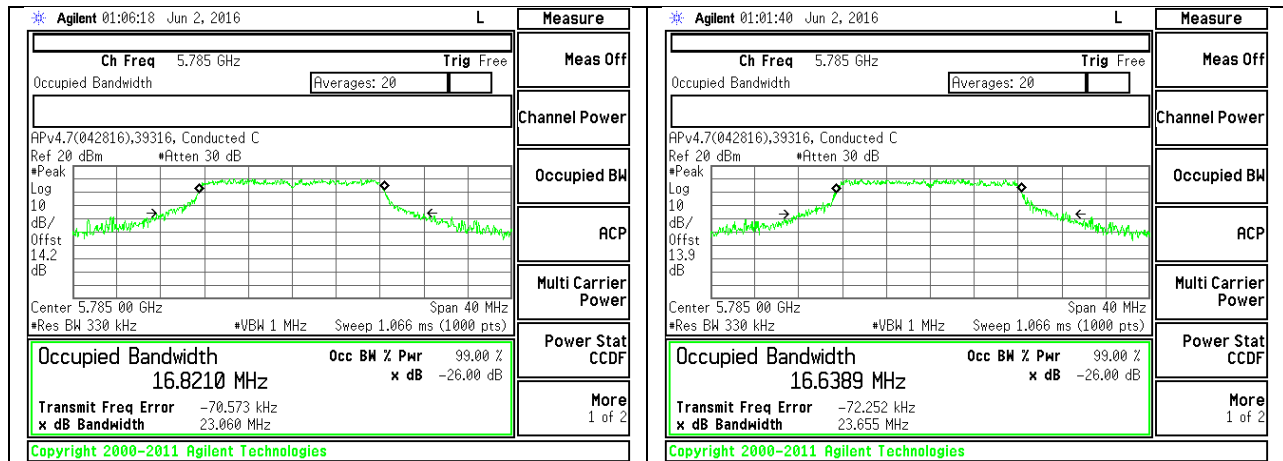

MID CHANNEL CHAIN 0

MID CHANNEL CHAIN 1

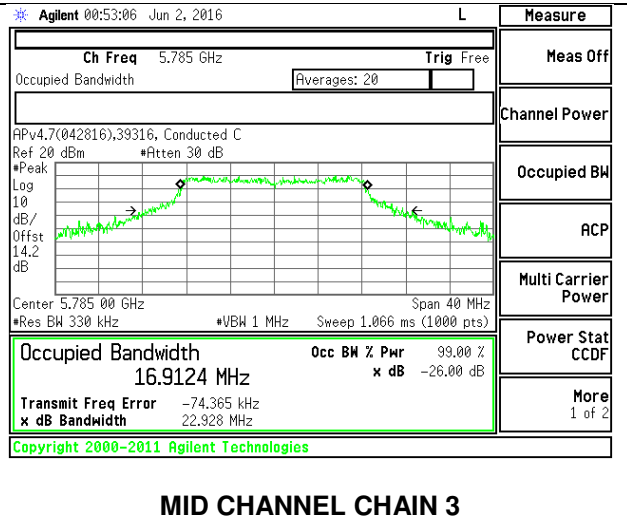
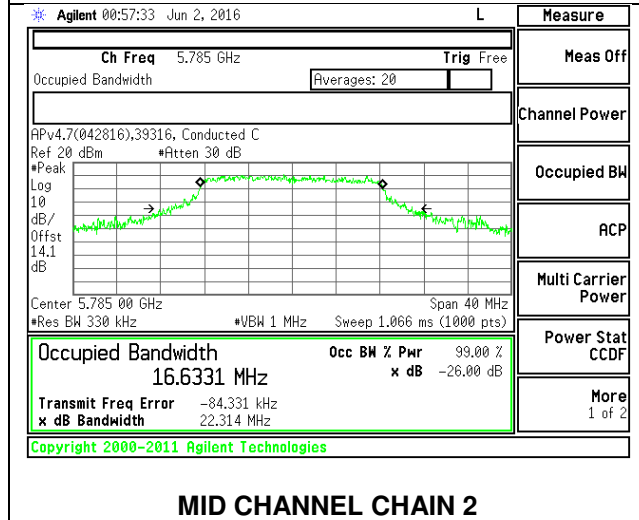

MID CHANNEL CHAIN 2

MID CHANNEL CHAIN 3

HIGH CHANNEL

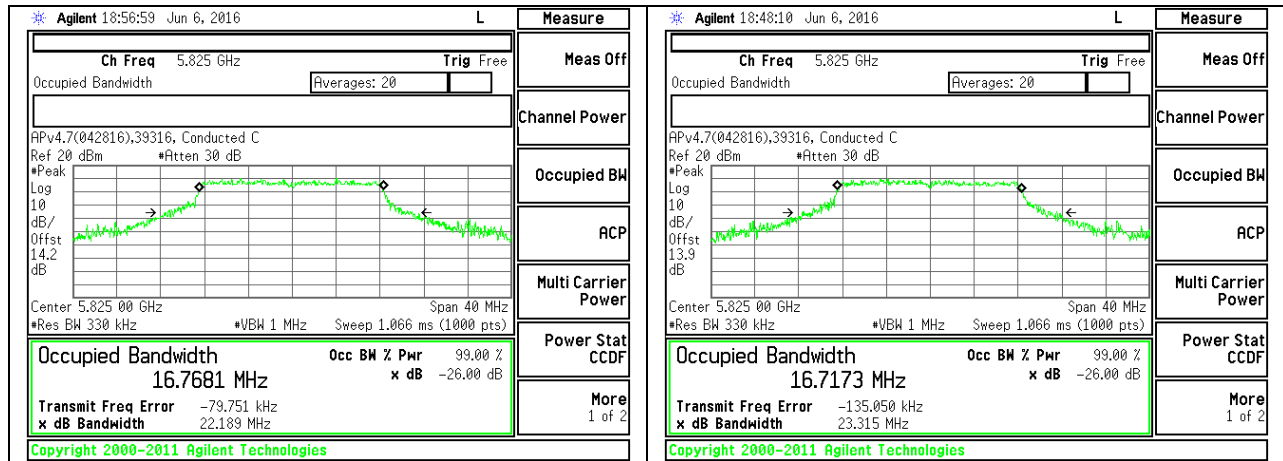

HIGH CHANNEL CHAIN 0

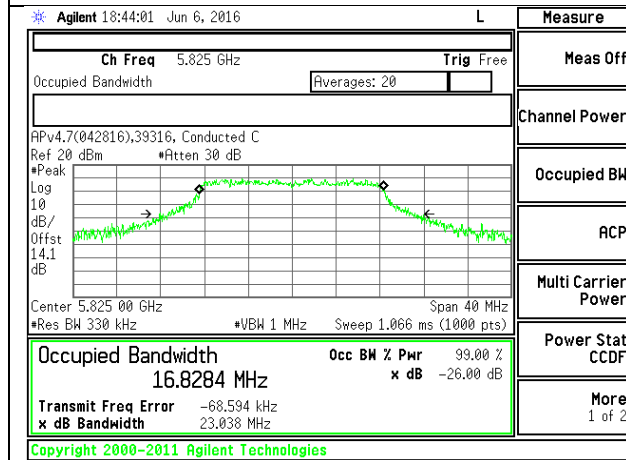

HIGH CHANNEL CHAIN 2

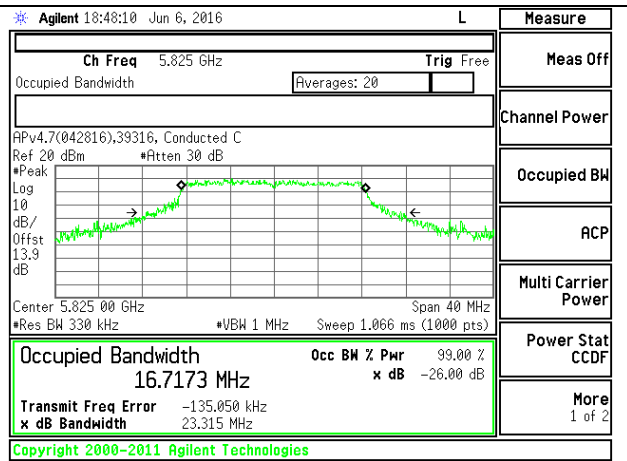

HIGH CHANNEL CHAIN 1

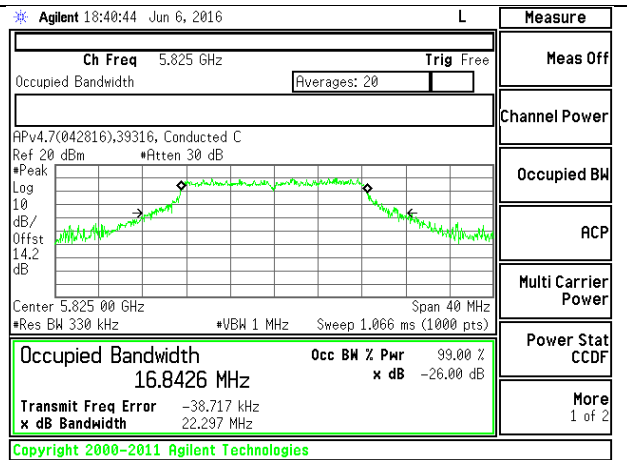

HIGH CHANNEL CHAIN 3

4.3.6. 802.11ac VHT20 MODE IN THE 5.8 GHz BAND

4 Tx CDD MODE

Channel	Frequency (MHz)	99% Bandwidth Chain 0 (MHz)	99% Bandwidth Chain 1 (MHz)	99% Bandwidth Chain 2 (MHz)	99% Bandwidth Chain 3 (MHz)
Low	5745	18.169	18.057	18.062	18.141
Mid	5785	18.173	18.068	18.075	18.164
High	5825	18.090	18.042	17.997	18.133

Test By: 37699 CS
 Test Date: 10/27/15

LOW CHANNEL

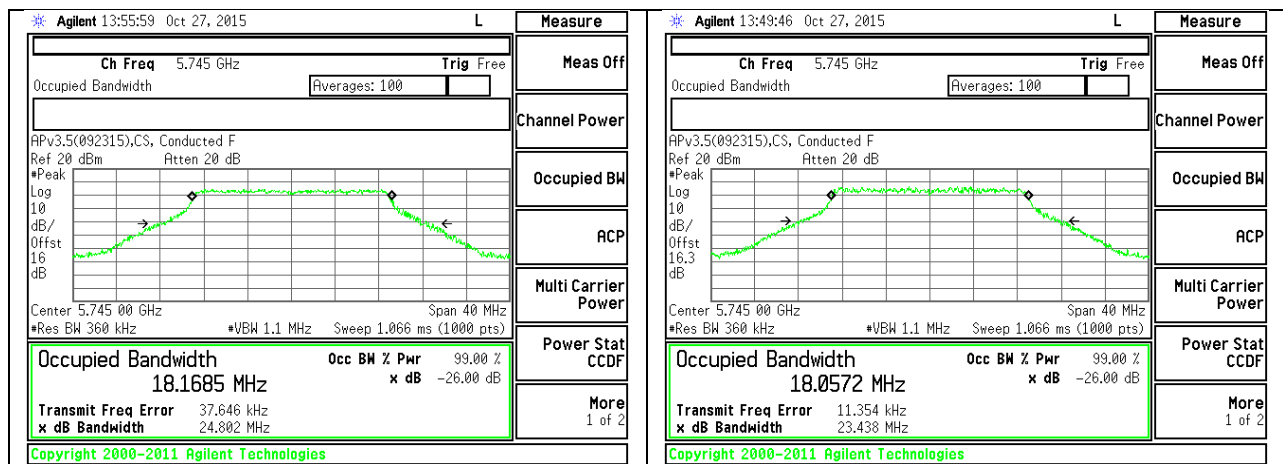

LOW CHANNEL CHAIN 0

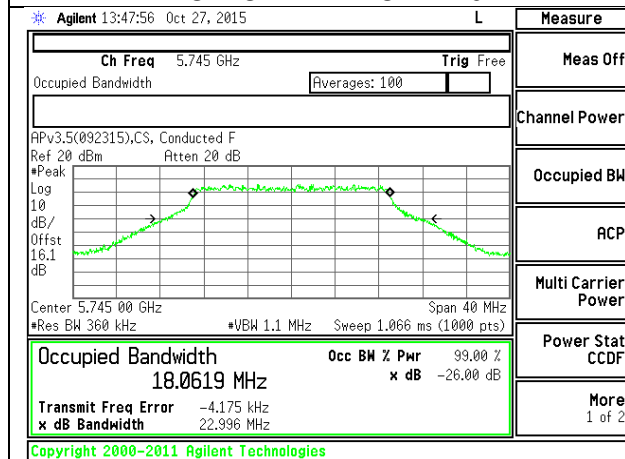

LOW CHANNEL CHAIN 1

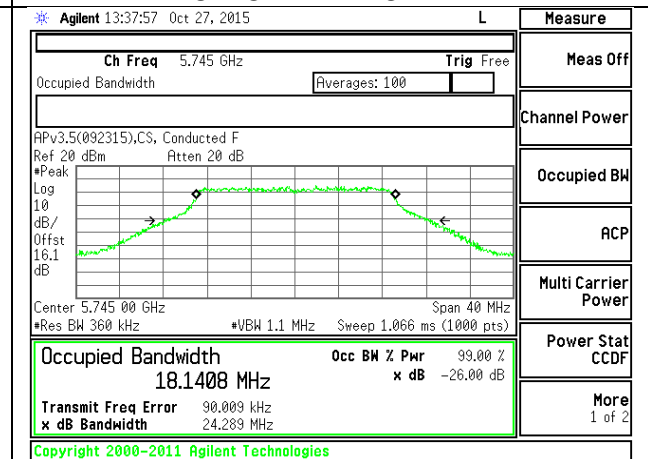

LOW CHANNEL CHAIN 2

LOW CHANNEL CHAIN 3

MID CHANNEL

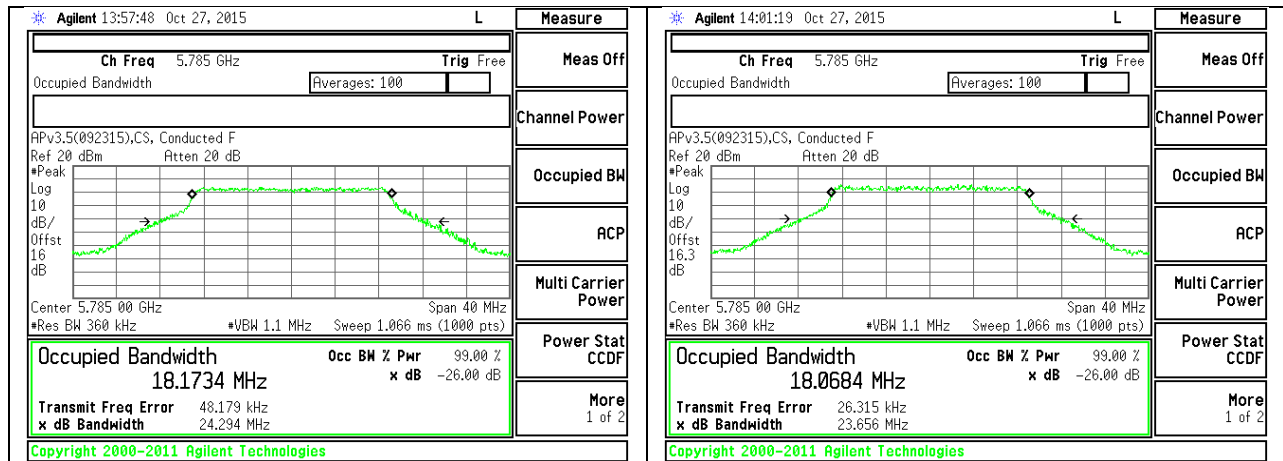

MID CHANNEL CHAIN 0

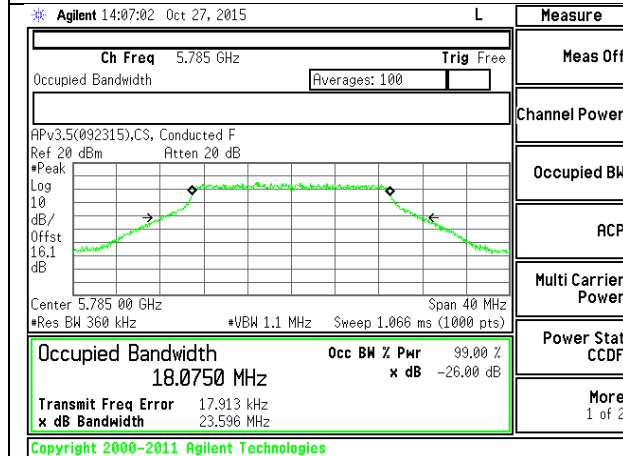

MID CHANNEL CHAIN 2

MID CHANNEL CHAIN 1

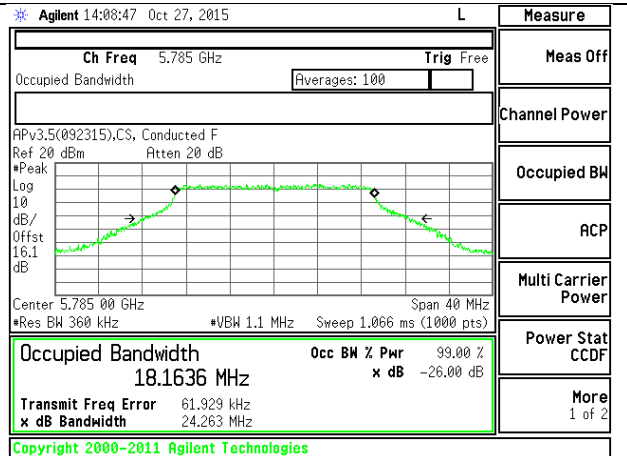

MID CHANNEL CHAIN 3

HIGH CHANNEL

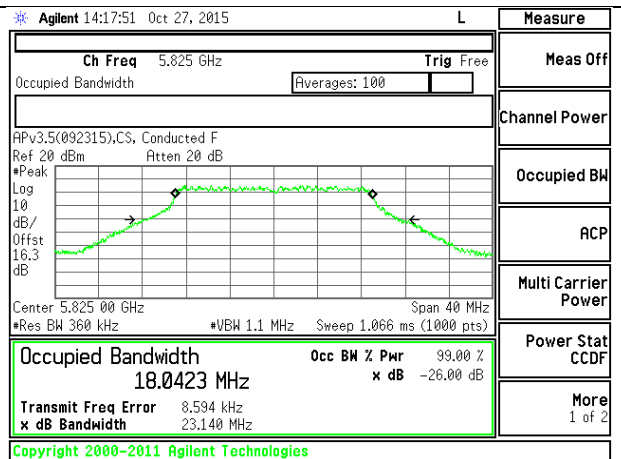
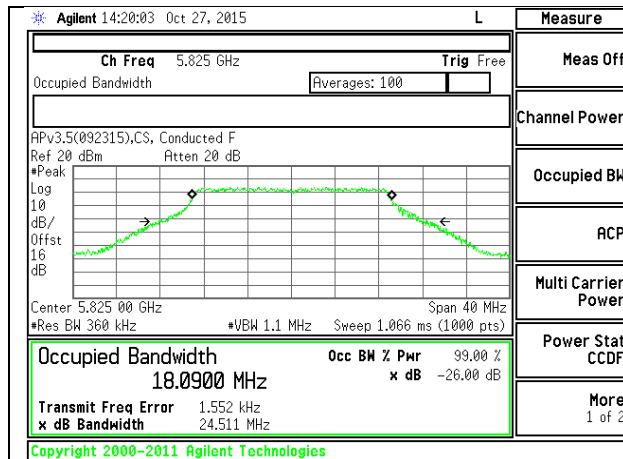

HIGH CHANNEL CHAIN 0

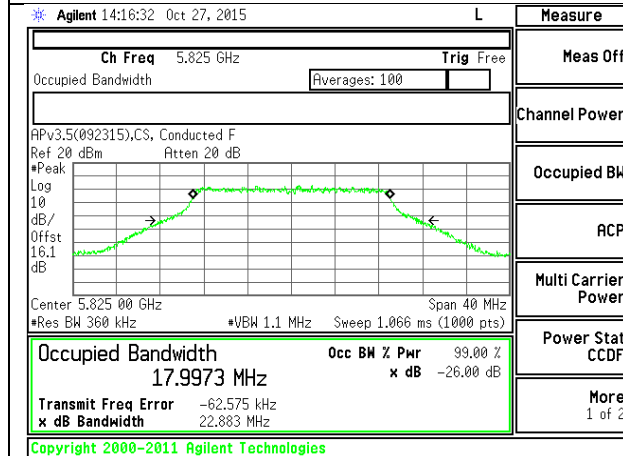

HIGH CHANNEL CHAIN 1

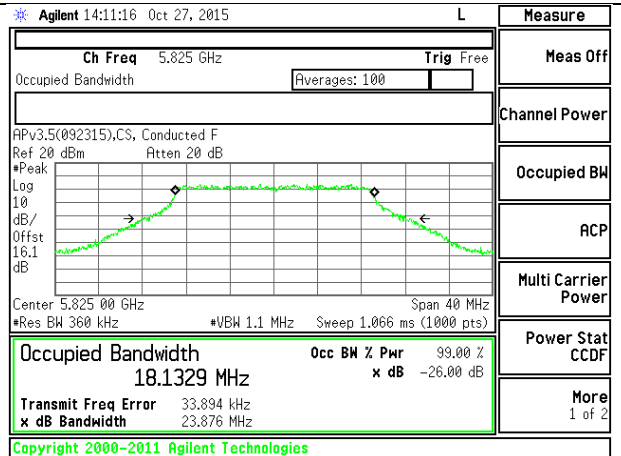

HIGH CHANNEL CHAIN 2

HIGH CHANNEL CHAIN 3

4.3.7. 802.11ac VHT40 MODE IN THE 5.8 GHz BAND

4 Tx CDD MODE

Channel	Frequency (MHz)	99% Bandwidth Chain 0 (MHz)	99% Bandwidth Chain 1 (MHz)	99% Bandwidth Chain 2 (MHz)	99% Bandwidth Chain 3 (MHz)
Low	5755	36.496	36.535	36.412	36.472
High	5795	36.603	36.586	36.443	36.424

Test By: 37699 CS
 Test Date: 10/27/15 – 10/28/15

LOW CHANNEL

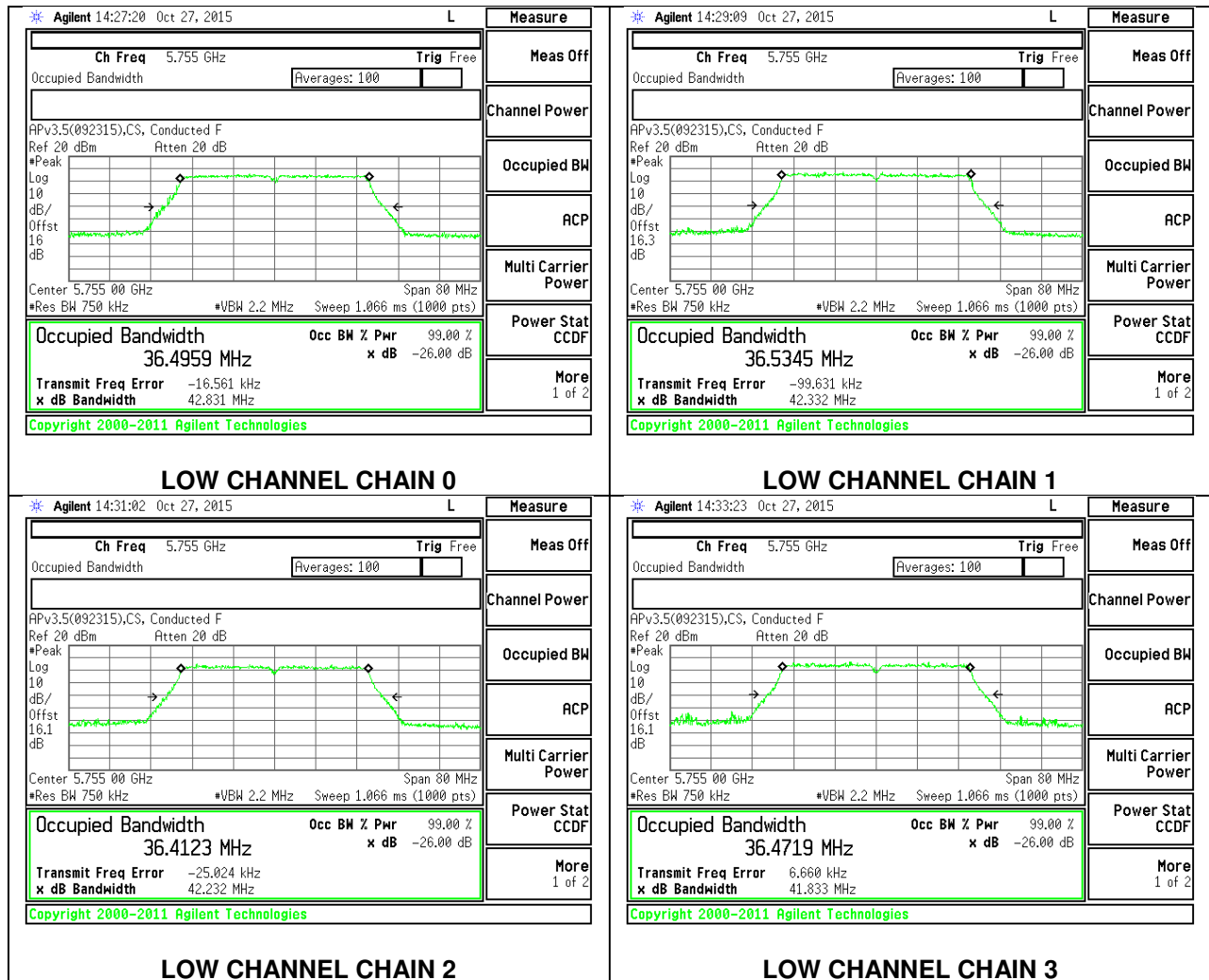

HIGH CHANNEL

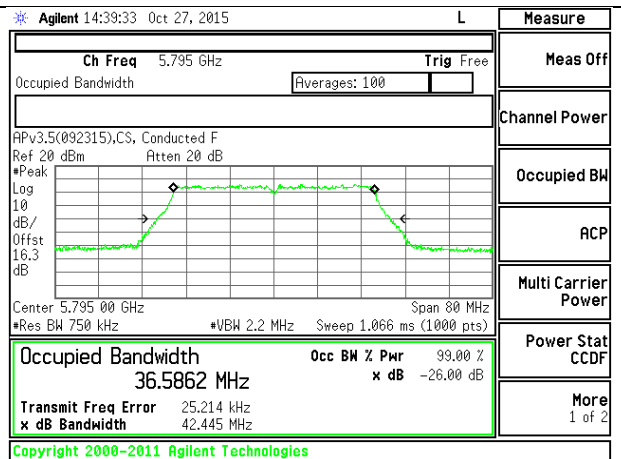
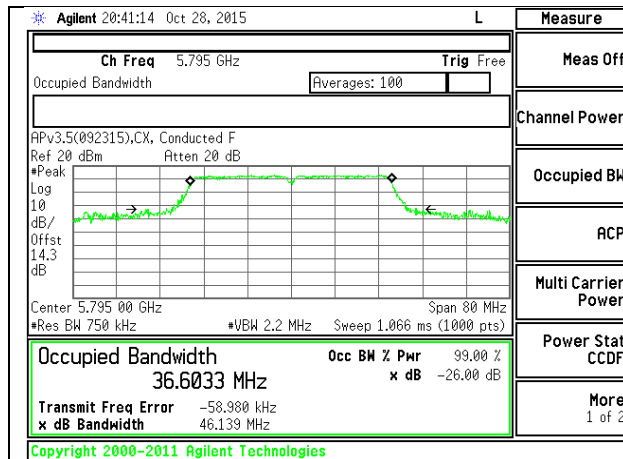

HIGH CHANNEL CHAIN 0

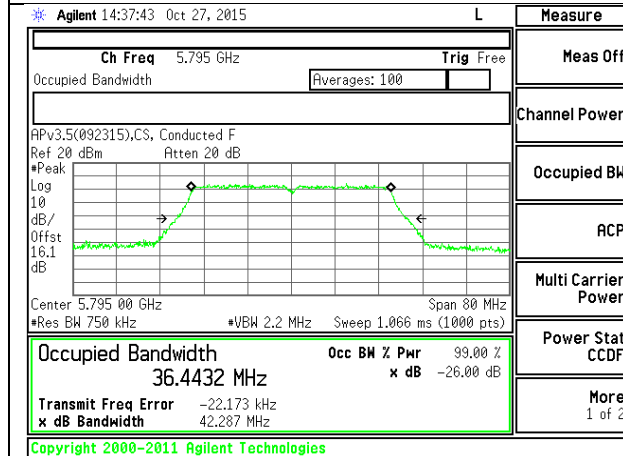

HIGH CHANNEL CHAIN 1

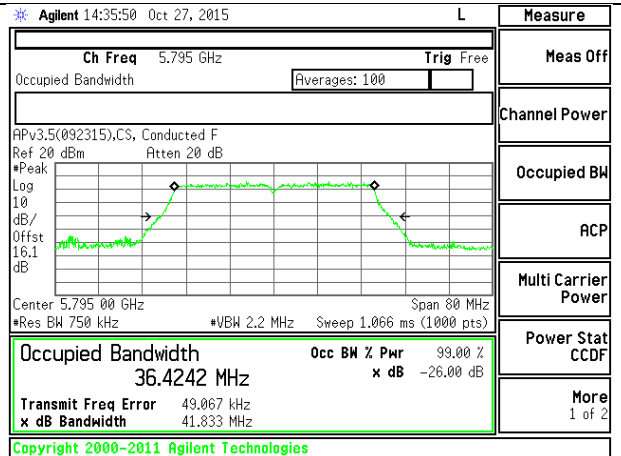

HIGH CHANNEL CHAIN 2

HIGH CHANNEL CHAIN 3

4.3.8. 802.11ac VHT80 MODE IN THE 5.8 GHz BAND

4 Tx CDD MODE

Channel	Frequency (MHz)	99% Bandwidth Chain 0 (MHz)	99% Bandwidth Chain 1 (MHz)	99% Bandwidth Chain 2 (MHz)	99% Bandwidth Chain 3 (MHz)
Mid	5775	75.387	75.439	75.511	75.346

Test By: 37699 CS
 Test Date: 10/27/15

MID CHANNEL

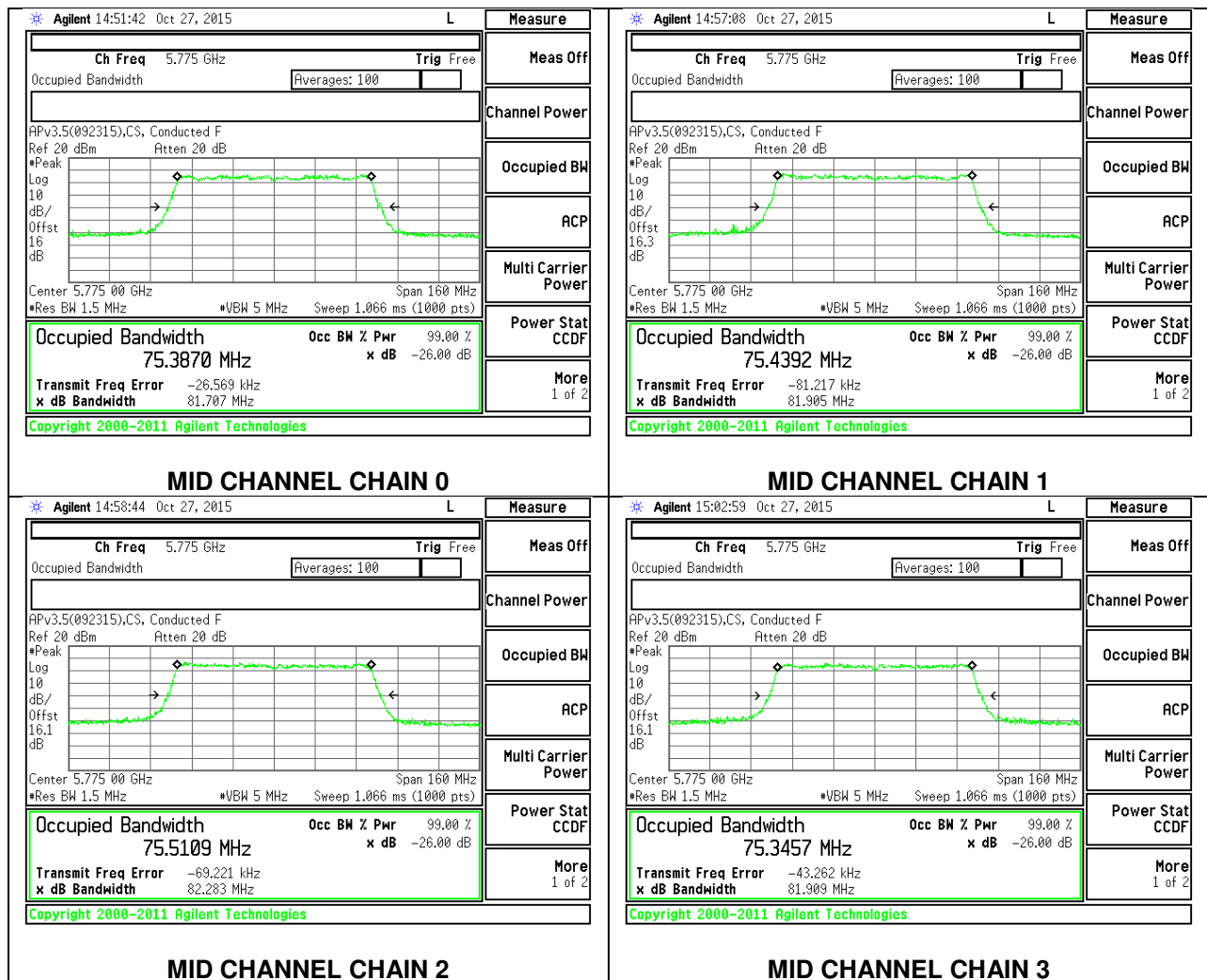

4.4. 6 dB BANDWIDTH

LIMITS

FCC §15.407
RSS-247 6.2.4

The minimum 6 dB bandwidth shall be at least 500 kHz.

TEST PROCEDURE

Reference to 789033 D02 General UNII Test Procedures New Rules v01: The transmitter output is connected to a spectrum analyzer with the RBW set to 100KHz, the VBW $\geq 3 \times$ RBW, peak detector and max hold.

RESULTS

4.4.1. 802.11a MODE IN THE 5.8 GHz BAND

4 Tx CDD MODE

Channel	Frequency (MHz)	6 dB Bandwidth Chain 0 (MHz)	6 dB Bandwidth Chain 1 (MHz)	6 dB Bandwidth Chain 2 (MHz)	6 dB Bandwidth Chain 3 (MHz)	Minimum Limit (MHz)
Low	5745	16.350	16.300	16.375	16.400	0.5
Mid	5785	16.375	16.325	15.936	16.375	0.5
High	5825	16.400	16.375	16.400	16.375	0.5

LOW CHANNEL

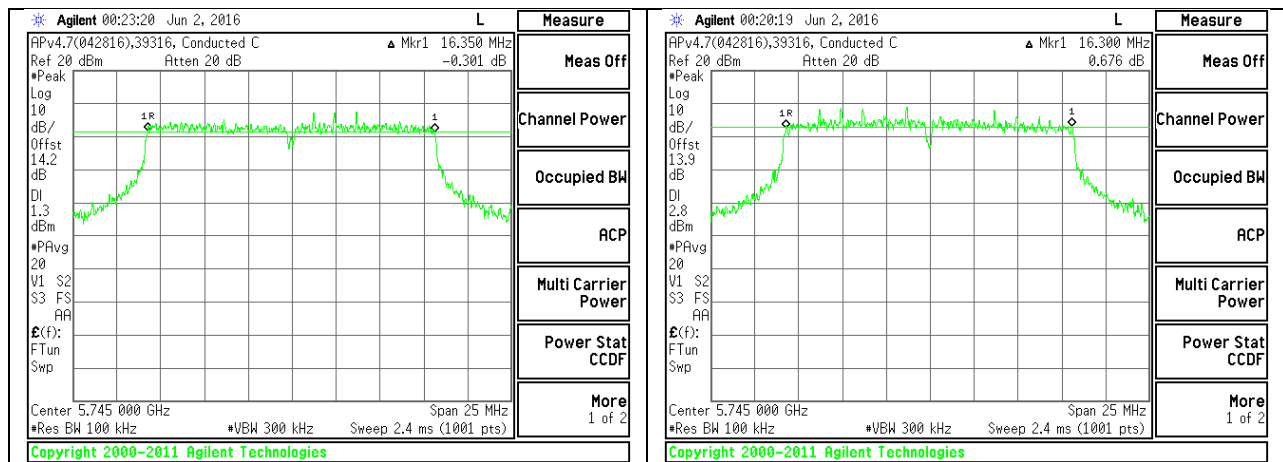

LOW CHANNEL CHAIN 0

LOW CHANNEL CHAIN 1

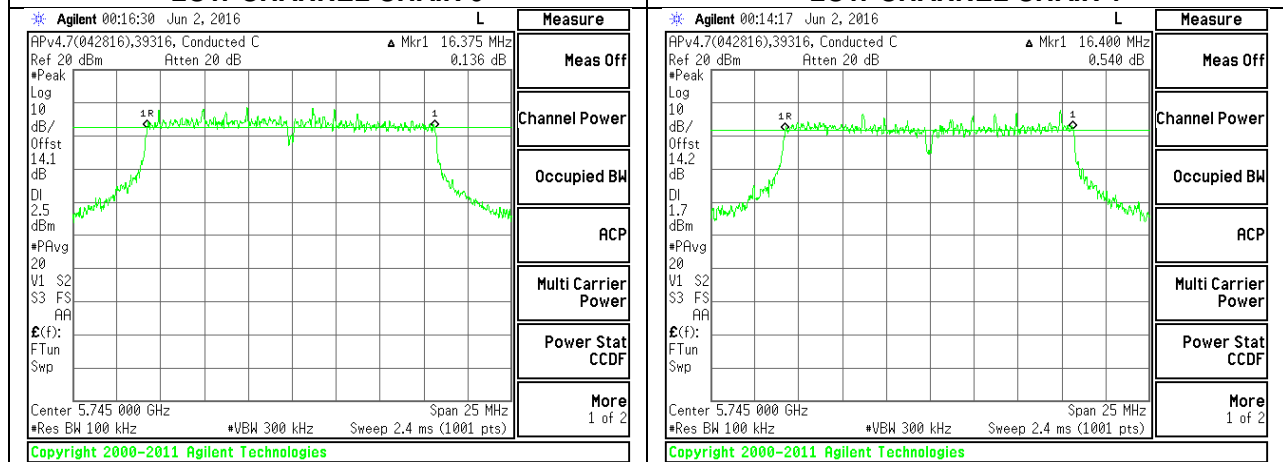

LOW CHANNEL CHAIN 2

LOW CHANNEL CHAIN 3

MID CHANNEL

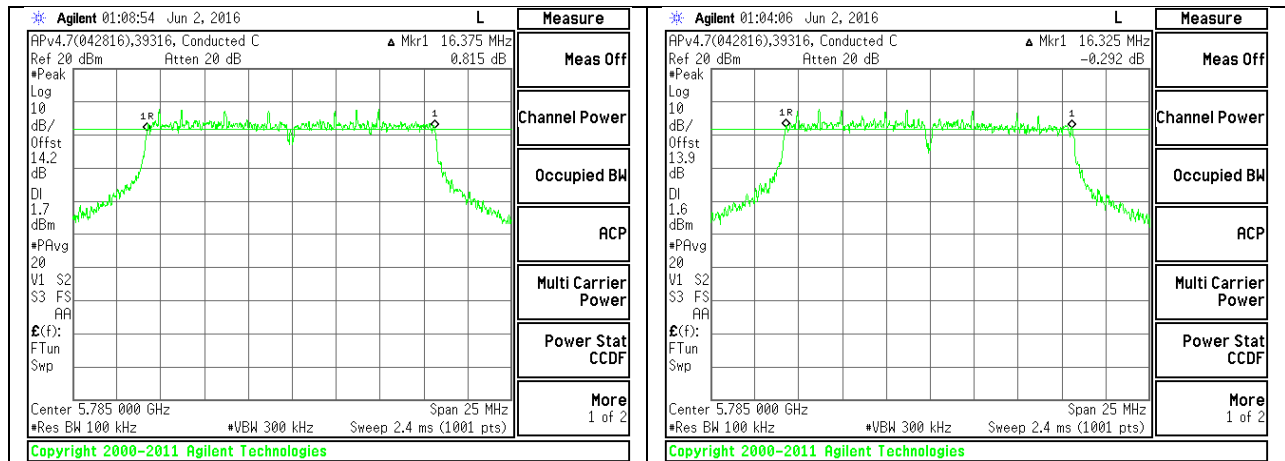

MID CHANNEL CHAIN 0

MID CHANNEL CHAIN 1

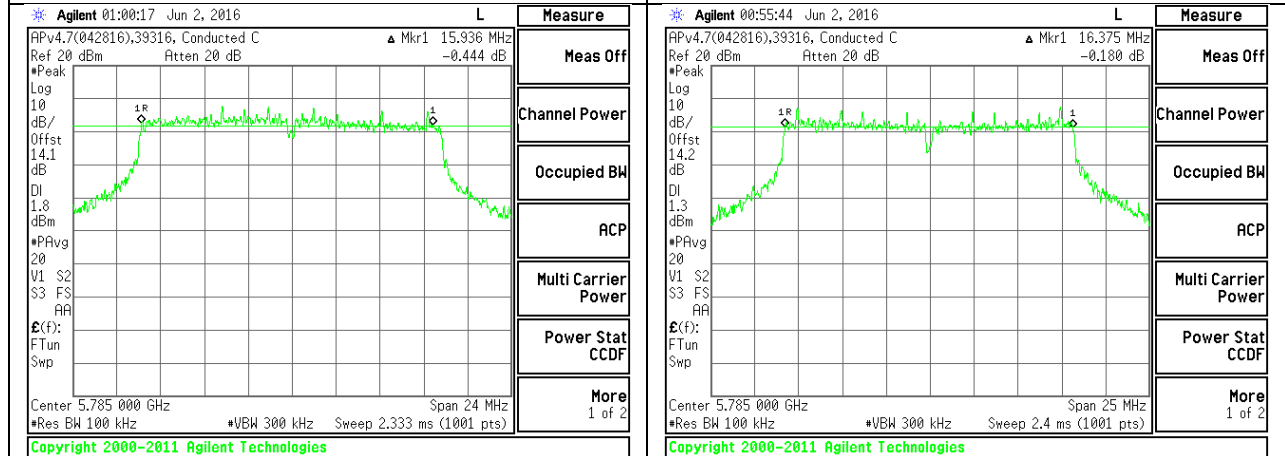

MID CHANNEL CHAIN 2

MID CHANNEL CHAIN 3

HIGH CHANNEL

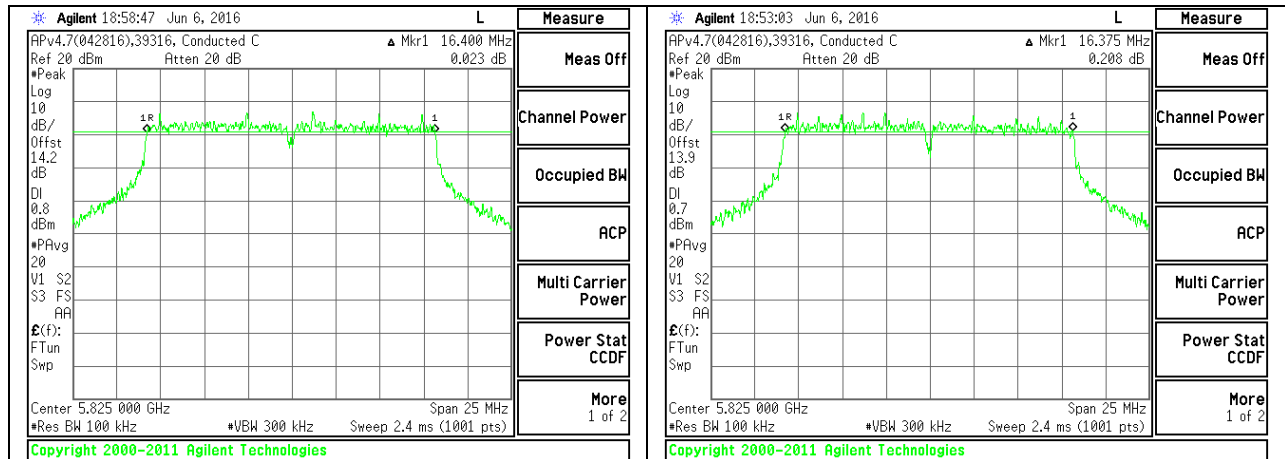

HIGH CHANNEL CHAIN 0

HIGH CHANNEL CHAIN 1

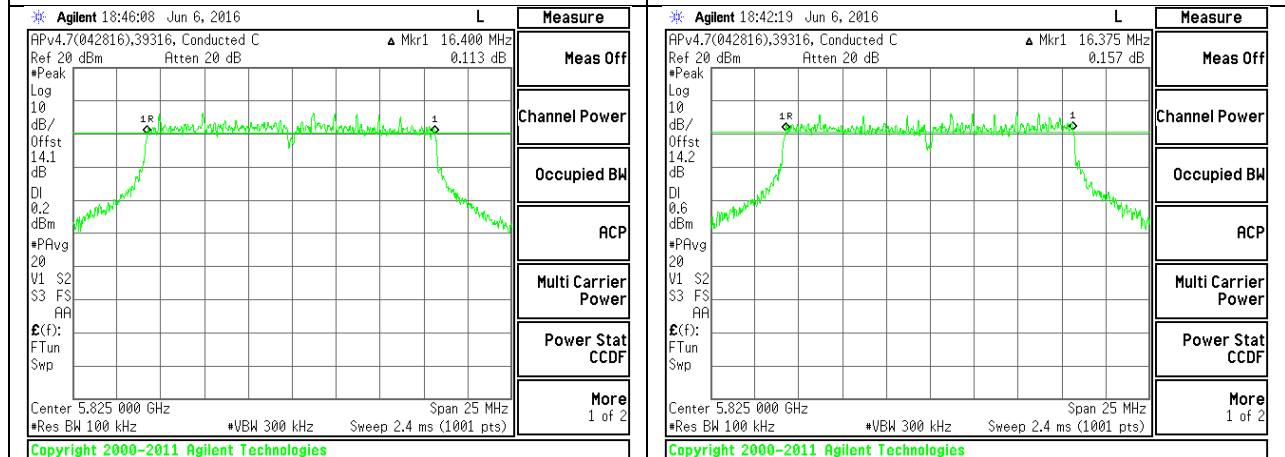

HIGH CHANNEL CHAIN 2

HIGH CHANNEL CHAIN 3

4.4.2. 802.11ac VHT20 MODE IN THE 5.8 GHz BAND

4 Tx CDD MODE

Channel	Frequency (MHz)	6 dB Bandwidth Chain 0 (MHz)	6 dB Bandwidth Chain 1 (MHz)	6 dB Bandwidth Chain 2 (MHz)	6 dB Bandwidth Chain 3 (MHz)	Minimum Limit (MHz)
Low	5745	17.739	17.631	17.604	17.577	0.5
Mid	5785	17.550	17.712	17.658	17.604	0.5
High	5825	17.604	17.739	17.631	17.685	0.5

Test By: 39316 CX
 Test Date: 10/27/15

LOW CHANNEL

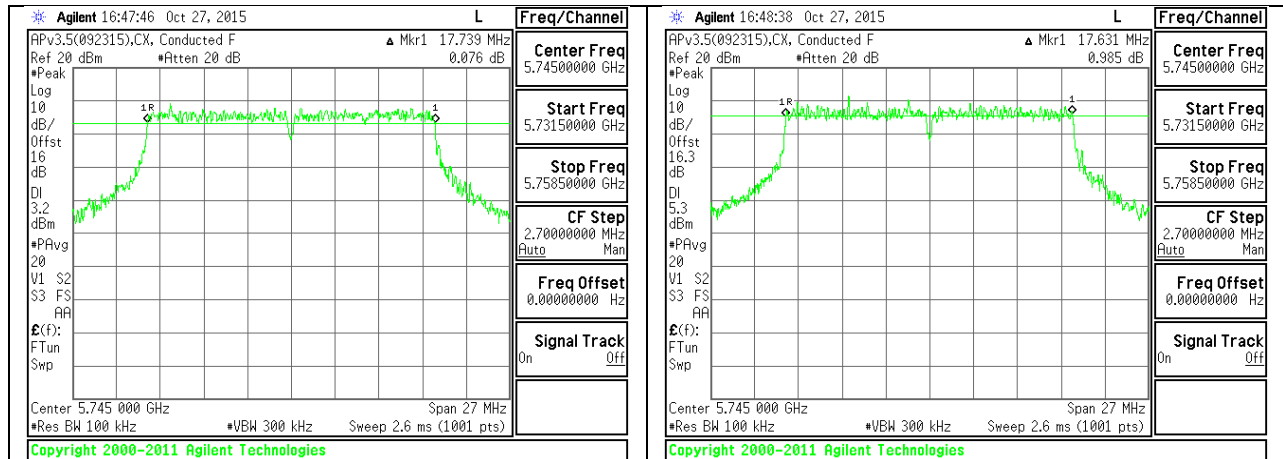

LOW CHANNEL CHAIN 0

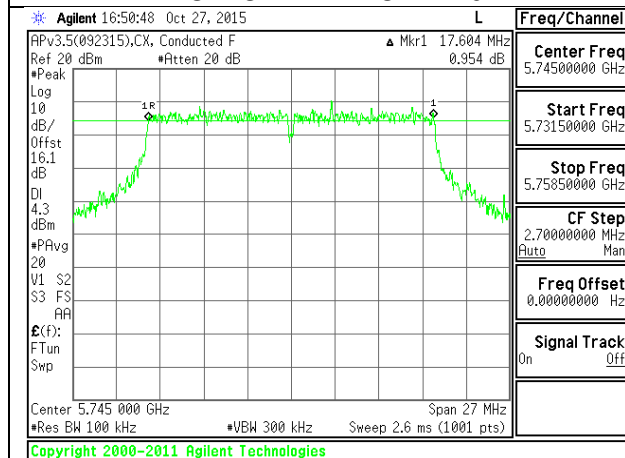

LOW CHANNEL CHAIN 1

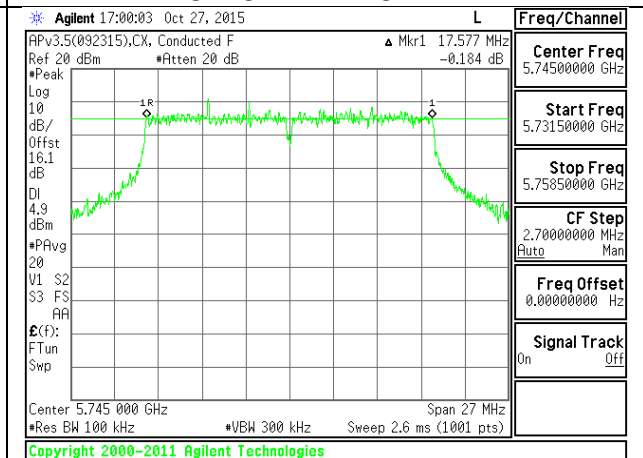

LOW CHANNEL CHAIN 2

LOW CHANNEL CHAIN 3

MID CHANNEL

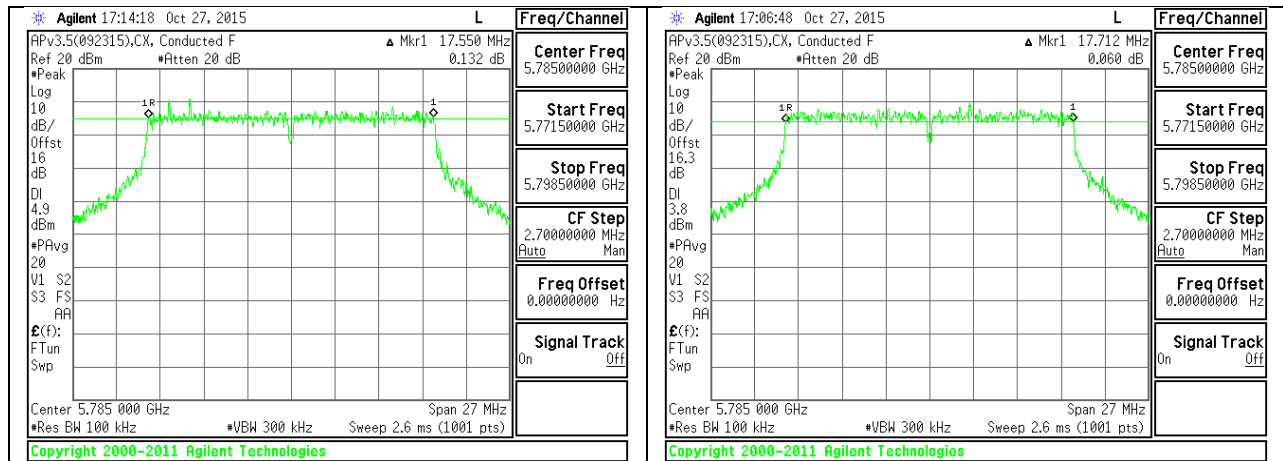

MID CHANNEL CHAIN 0

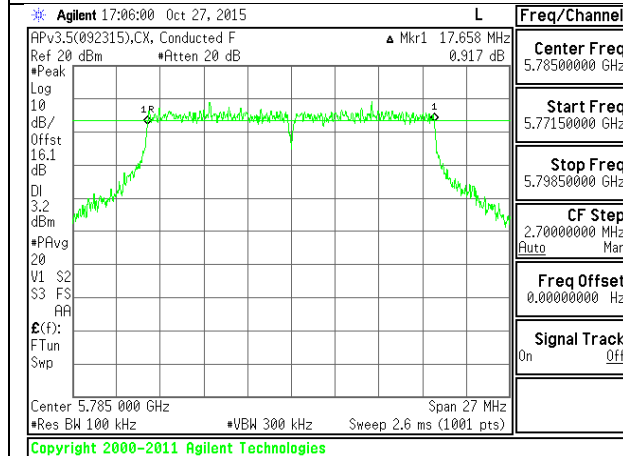

MID CHANNEL CHAIN 1

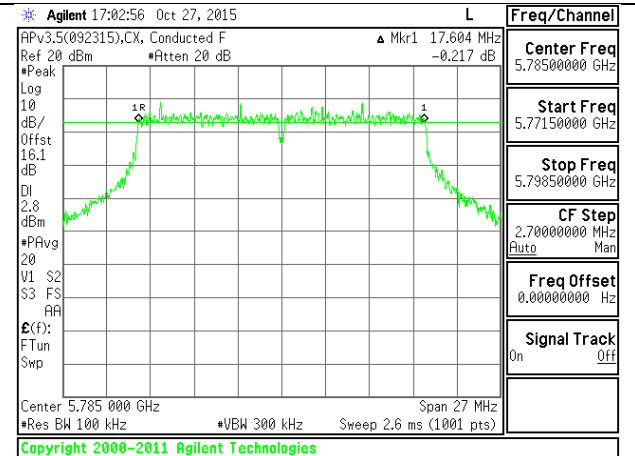

MID CHANNEL CHAIN 2



MID CHANNEL CHAIN 3



HIGH CHANNEL

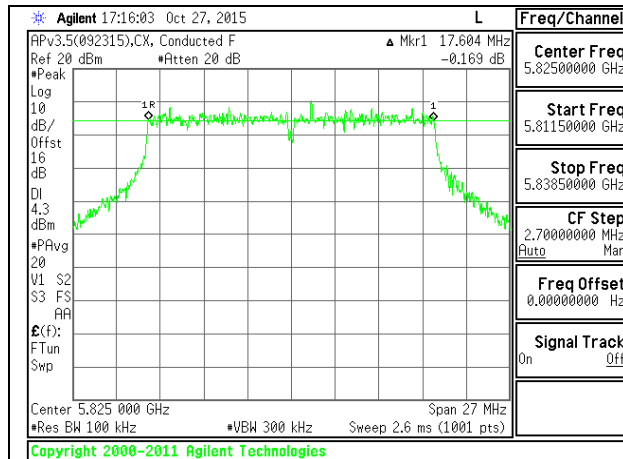

HIGH CHANNEL CHAIN 0

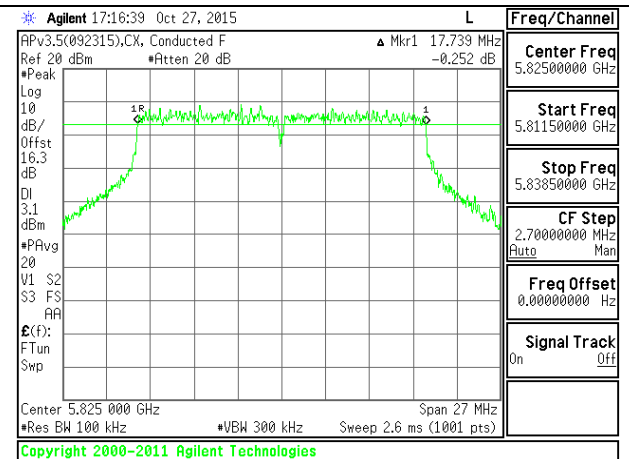

HIGH CHANNEL CHAIN 1

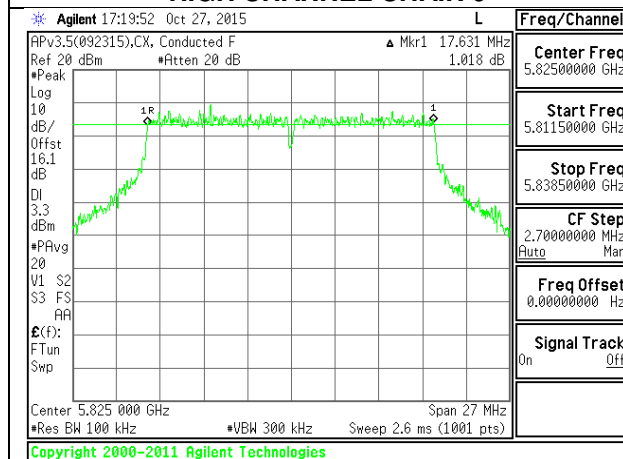

HIGH CHANNEL CHAIN 2

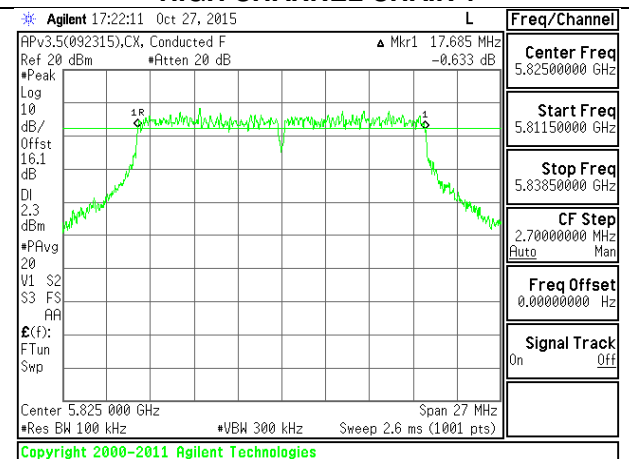

HIGH CHANNEL CHAIN 3

4.4.3. 802.11ac VHT40 MODE IN THE 5.8 GHz BAND

4 Tx CDD MODE

Channel	Frequency (MHz)	6 dB Bandwidth Chain 0 (MHz)	6 dB Bandwidth Chain 1 (MHz)	6 dB Bandwidth Chain 2 (MHz)	6 dB Bandwidth Chain 3 (MHz)	Minimum Limit (MHz)
Low	5755	36.080	36.355	36.080	36.300	0.5
High	5795	35.964	36.410	36.300	36.025	0.5

Test By: 39316 CX

Test Date: 10/27/15

LOW CHANNEL

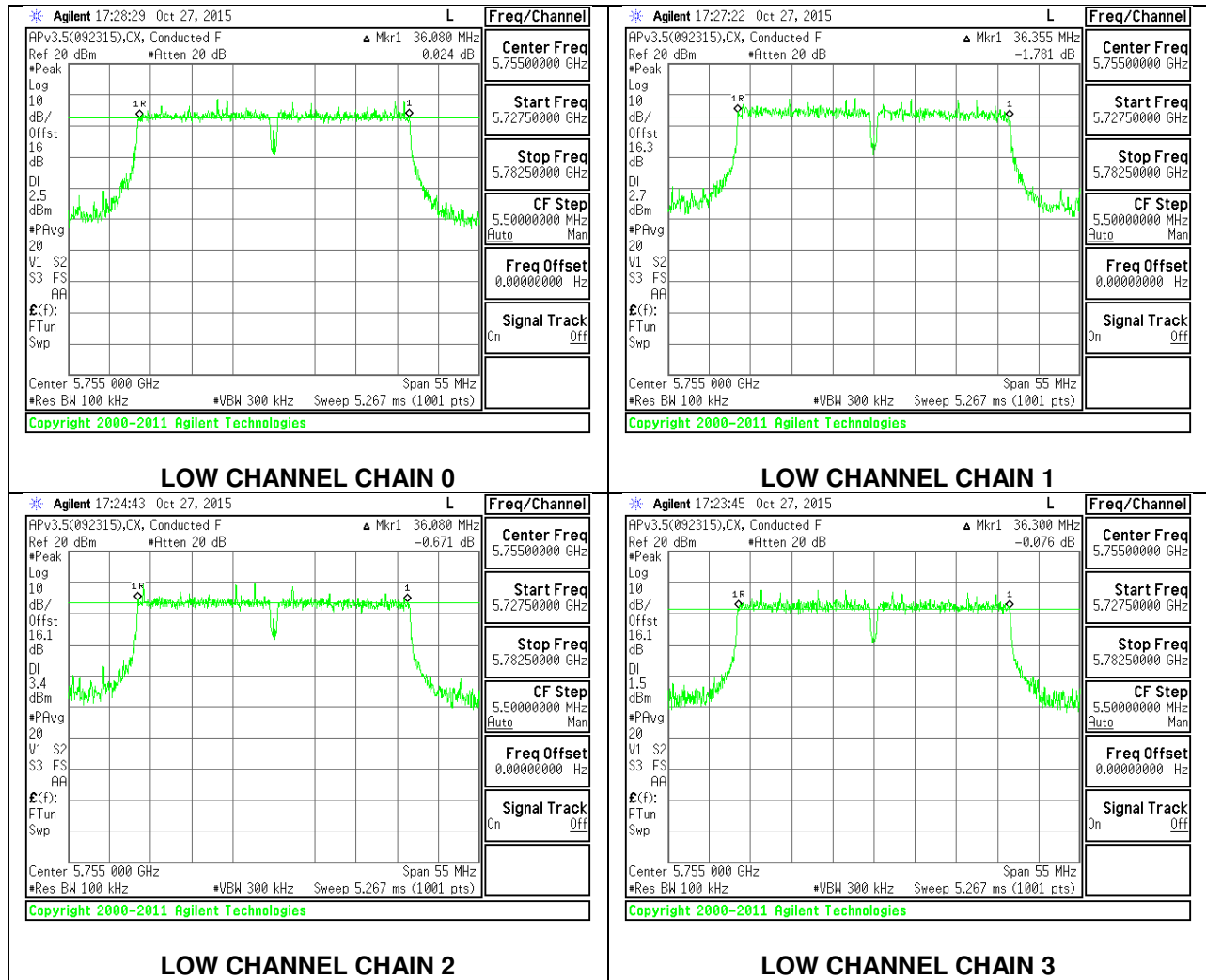

HIGH CHANNEL

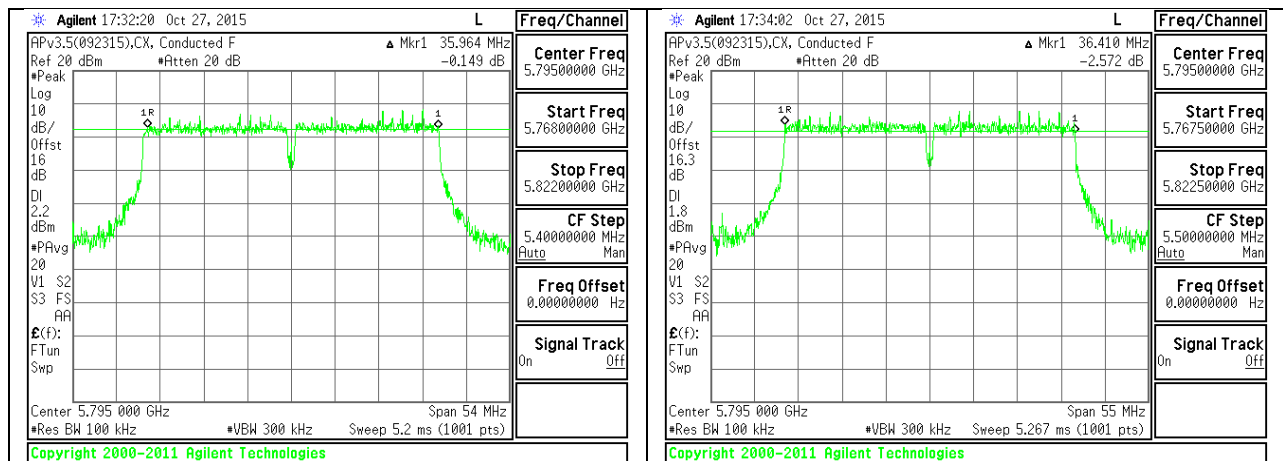

HIGH CHANNEL CHAIN 0

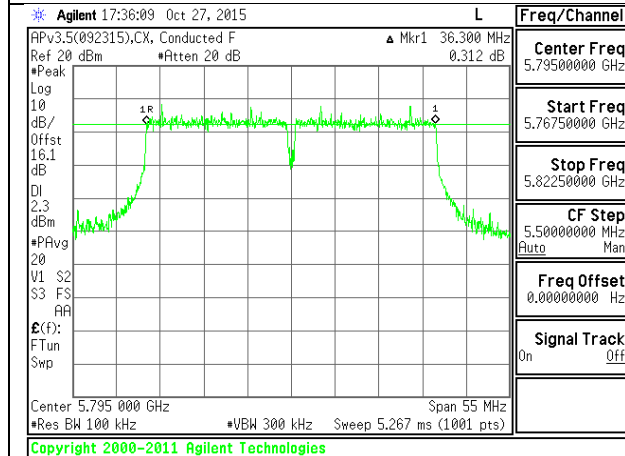

HIGH CHANNEL CHAIN 1

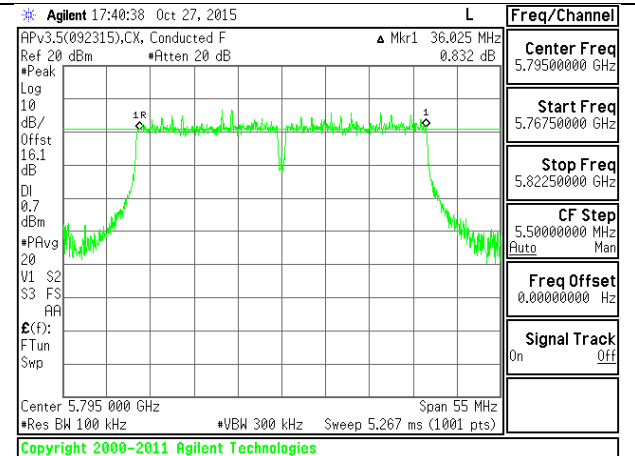

HIGH CHANNEL CHAIN 2



HIGH CHANNEL CHAIN 3



4.4.4. 802.11ac VHT80 MODE IN THE 5.8 GHz BAND

4 Tx CDD MODE

Channel	Frequency (MHz)	6 dB Bandwidth Chain 0 (MHz)	6 dB Bandwidth Chain 1 (MHz)	6 dB Bandwidth Chain 2 (MHz)	6 dB Bandwidth Chain 3 (MHz)	Minimum Limit (MHz)
Mid	5775	75.260	75.140	74.480	74.140	0.5

Test By: 39316 CX
 Test Date: 10/27/15

MID CHANNEL

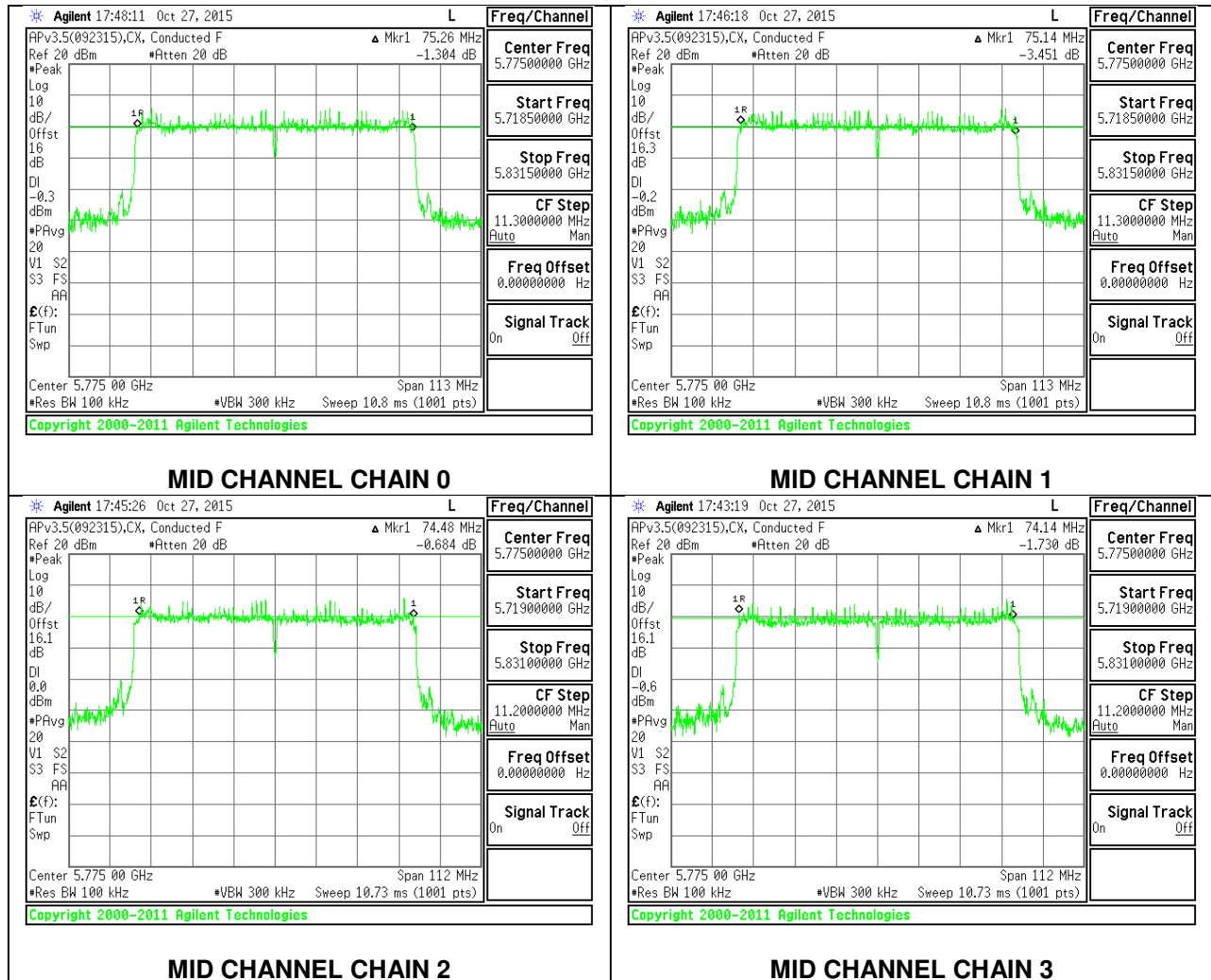

4.5. OUTPUT POWER AND PPSD

LIMITS

FCC §15.407 (a)

(1)(ii) For an indoor access point operating in the band 5.15-5.25 GHz, the maximum conducted output power over the frequency band of operation shall not exceed 1 W provided the maximum antenna gain does not exceed 6 dBi. In addition, the maximum power spectral density shall not exceed 17 dBm in any 1 megahertz band. If transmitting antennas of directional gain greater than 6 dBi are used, both the maximum conducted output power and the maximum power spectral density shall be reduced by the amount in dB that the directional gain of the antenna exceeds 6 dBi.

(2) For the 5.25-5.35 GHz and 5.47-5.725 GHz bands, the maximum conducted output power over the frequency bands of operation shall not exceed the lesser of 250 mW or $11 \text{ dBm} + 10 \log B$, where B is the 26 dB emission bandwidth in megahertz. In addition, the maximum power spectral density shall not exceed 11 dBm in any 1 megahertz band. If transmitting antennas of directional gain greater than 6 dBi are used, both the maximum conducted output power and the maximum power spectral density shall be reduced by the amount in dB that the directional gain of the antenna exceeds 6 dBi.

(3) For the band 5.725-5.85 GHz, the maximum conducted output power over the frequency band of operation shall not exceed 1 W. In addition, the maximum power spectral density shall not exceed 30 dBm in any 500-kHz band.

DIRECTIONAL ANTENNA GAIN

Frequency Band (GHz)	Directional Antenna Gain			
	1	2	3	4
	Spatial Stream (dBi)	Spatial Streams (dBi)	Spatial Streams (dBi)	Spatial Streams (dBi)
5.2	9.92	6.95	6.03	3.98
5.8	9.95	6.99	6.07	4.01

RESULTS

4.5.1. 802.11a MODE IN THE 5.2 GHz BAND

4Tx 1 STREAM CDD MODE

Antenna Gain and Limits

Channel	Frequency (MHz)	Directional Gain for Power (dBi)	Directional Gain for PSD (dBi)	Power Limit (dBm)	PSD Limit (dBm)
Low	5180	3.98	9.92	30.00	13.08
Mid	5200	3.98	9.92	30.00	13.08
High	5240	3.98	9.92	30.00	13.08

Duty Cycle CF (dB)	0.31	Included in Calculations of Corr'd Power & PSD
---------------------------	------	---

Output Power Results

Channel	Frequency (MHz)	Chain 0 Meas Power (dBm)	Chain 1 Meas Power (dBm)	Chain 2 Meas Power (dBm)	Chain 3 Meas Power (dBm)	Total Corr'd Power (dBm)	Power Limit (dBm)	Power Margin (dB)
Low	5180	15.38	15.15	14.87	15.33	21.52	30.00	-8.48
Mid	5200	18.18	17.38	17.51	18.22	24.17	30.00	-5.83
High	5240	17.35	17.04	17.13	17.43	23.57	30.00	-6.43

PSD Results

Channel	Frequency (MHz)	Chain 0 Meas PSD (dBm)	Chain 1 Meas PSD (dBm)	Chain 2 Meas PSD (dBm)	Chain 3 Meas PSD (dBm)	Total Corr'd PSD (dBm)	PSD Limit (dBm)	PSD Margin (dB)
Low	5180	3.95	3.86	3.43	4.03	10.15	13.08	-2.93
Mid	5200	7.30	6.28	6.07	6.81	12.97	13.08	-0.11
High	5240	6.15	5.65	5.70	5.92	12.19	13.08	-0.89

LOW CHANNEL

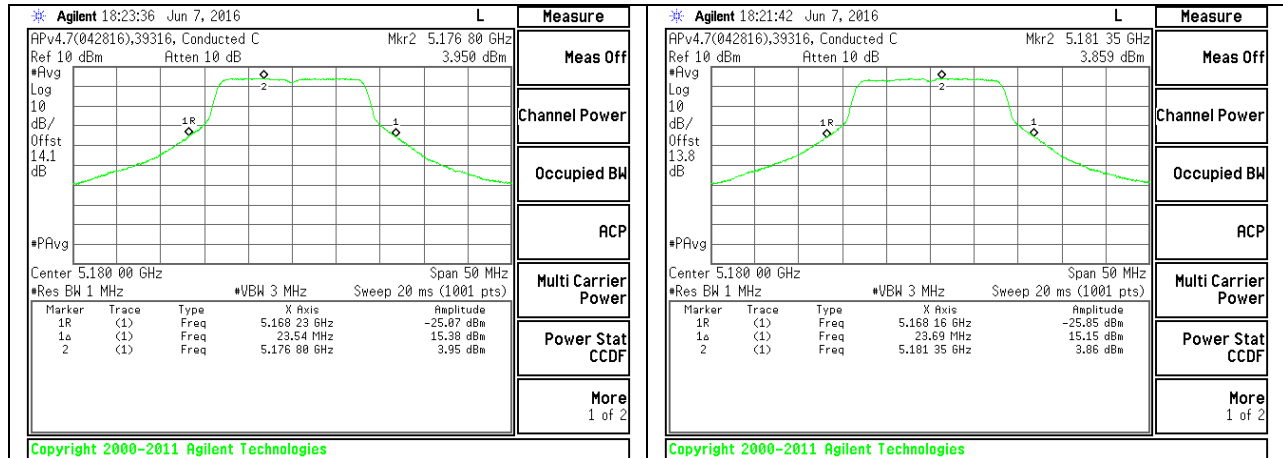

LOW CHANNEL CHAIN 0

LOW CHANNEL CHAIN 1

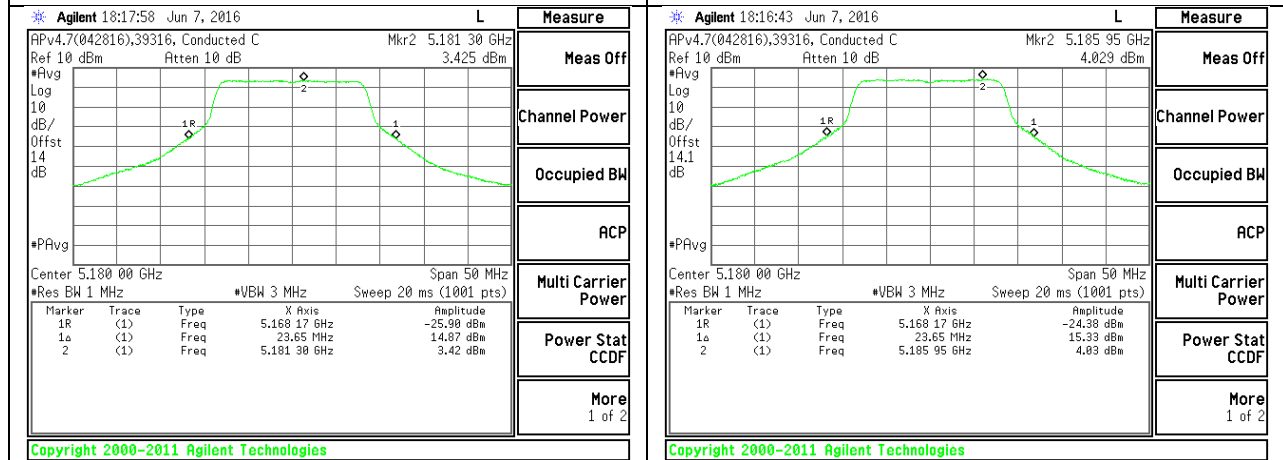

LOW CHANNEL CHAIN 2

LOW CHANNEL CHAIN 3

MID CHANNEL

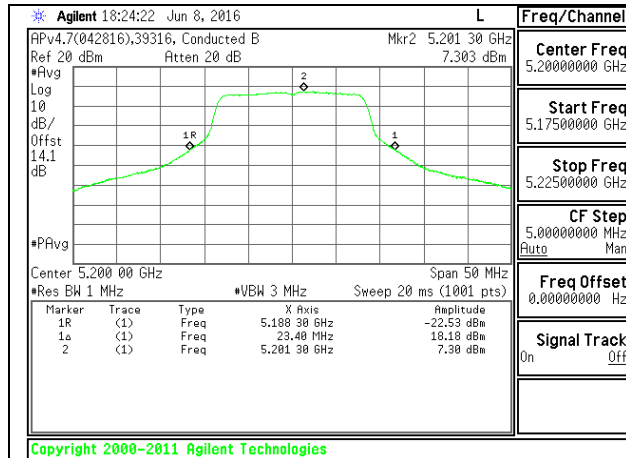

MID CHANNEL CHAIN 0

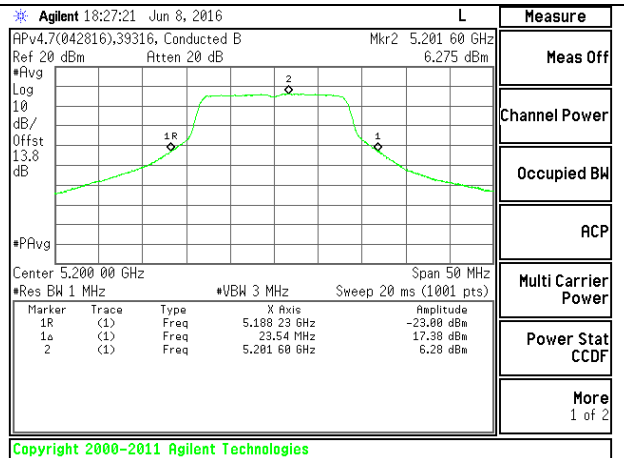

MID CHANNEL CHAIN 1

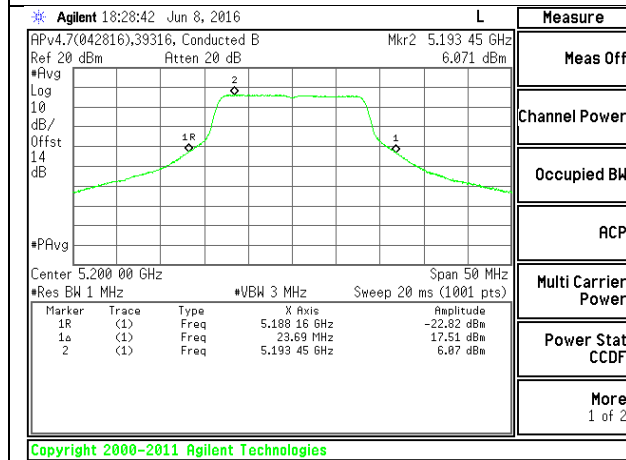

MID CHANNEL CHAIN 2

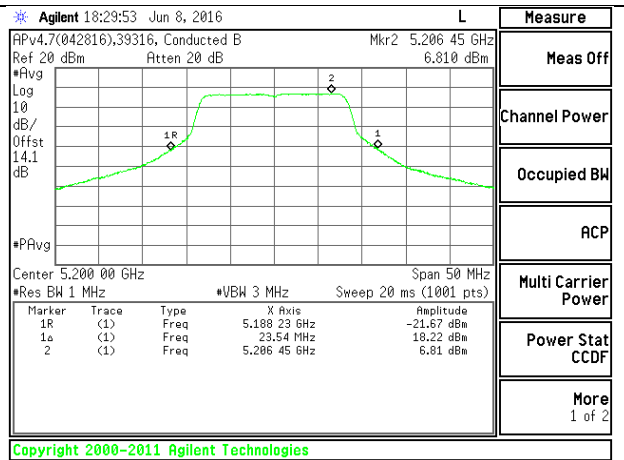

MID CHANNEL CHAIN 3

HIGH CHANNEL

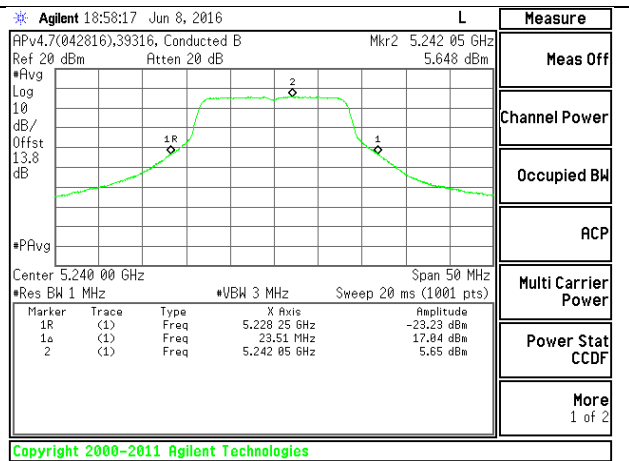
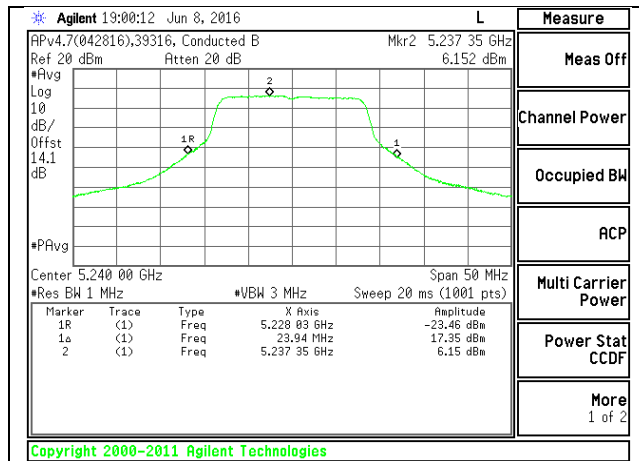

HIGH CHANNEL CHAIN 0

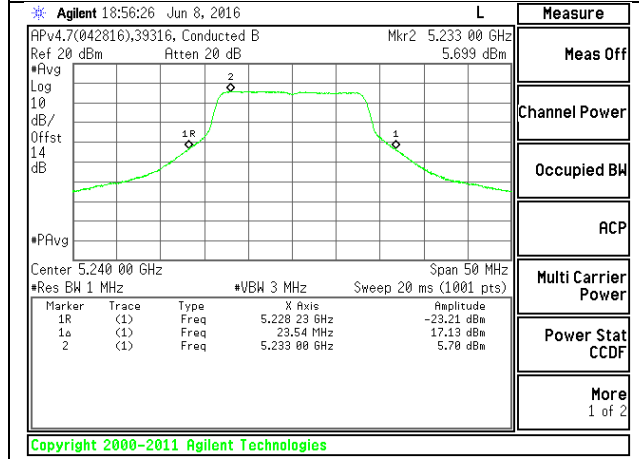

HIGH CHANNEL CHAIN 1

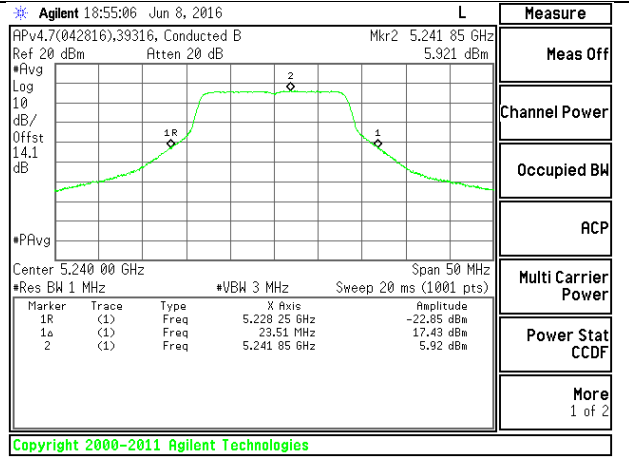

HIGH CHANNEL CHAIN 2

HIGH CHANNEL CHAIN 3

4.5.2. 802.11ac VHT20 MODE IN THE 5.2 GHz BAND

4Tx 4 STREAM CDD MODE

Antenna Gain and Limits

Channel	Frequency (MHz)	Directional Gain for Power (dBi)	Directional Gain for PSD (dBi)	Power Limit (dBm)	PSD Limit (dBm)
Low	5180	3.98	3.98	30.00	17.00
Mid	5200	3.98	3.98	30.00	17.00
High	5240	3.98	3.98	30.00	17.00

Duty Cycle CF (dB)	0.18	Included in Calculations of Corr'd Power & PSD
---------------------------	------	---

Output Power Results

Channel	Frequency (MHz)	Chain 0 Meas Power (dBm)	Chain 1 Meas Power (dBm)	Chain 2 Meas Power (dBm)	Chain 3 Meas Power (dBm)	Total Corr'd Power (dBm)	Power Limit (dBm)	Power Margin (dB)
Low	5180	18.39	18.87	18.15	18.42	24.67	30.00	-5.33
Mid	5200	20.99	20.93	20.56	21.00	27.07	30.00	-2.93
High	5240	21.09	21.20	20.92	21.01	27.26	30.00	-2.74

PSD Results

Channel	Frequency (MHz)	Chain 0 Meas PSD (dBm)	Chain 1 Meas PSD (dBm)	Chain 2 Meas PSD (dBm)	Chain 3 Meas PSD (dBm)	Total Corr'd PSD (dBm)	PSD Limit (dBm)	PSD Margin (dB)
Low	5180	6.56	7.04	6.34	6.65	12.85	17.00	-4.15
Mid	5200	9.00	8.96	8.59	9.05	15.10	17.00	-1.90
High	5240	9.18	9.25	8.98	9.06	15.32	17.00	-1.68

LOW CHANNEL

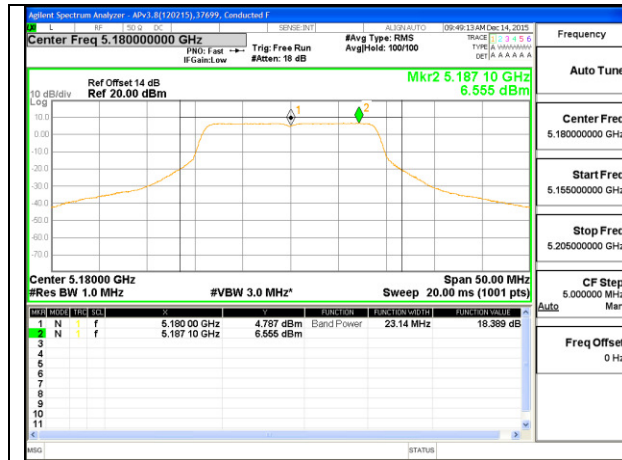

LOW CHANNEL CHAIN 0

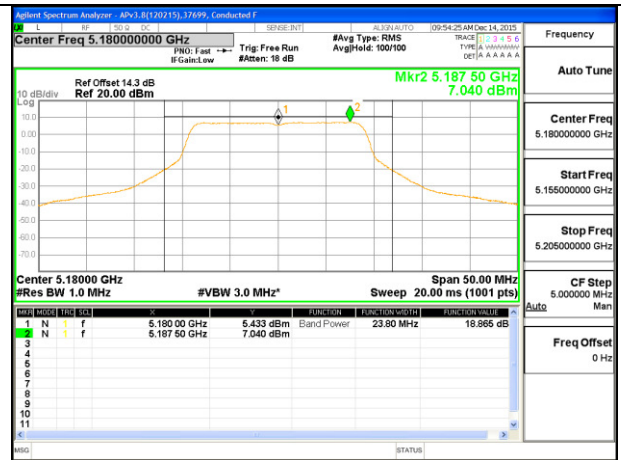

LOW CHANNEL CHAIN 1

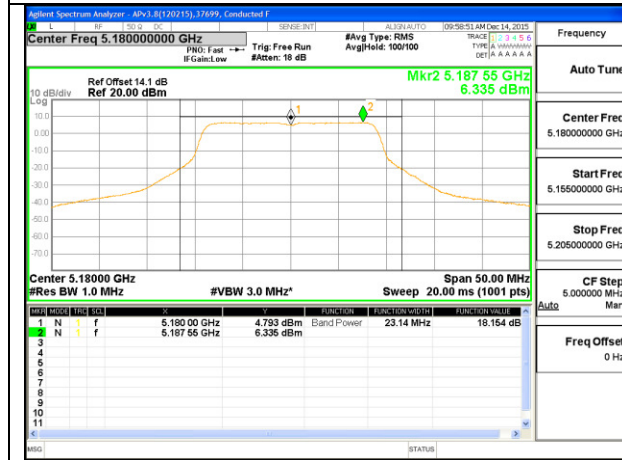

LOW CHANNEL CHAIN 2

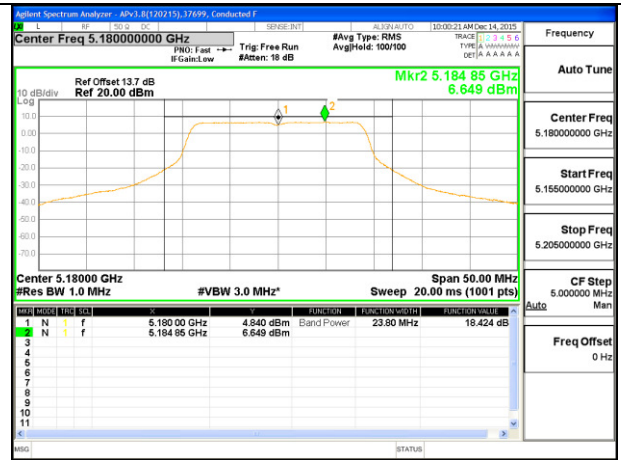

LOW CHANNEL CHAIN 3

MID CHANNEL

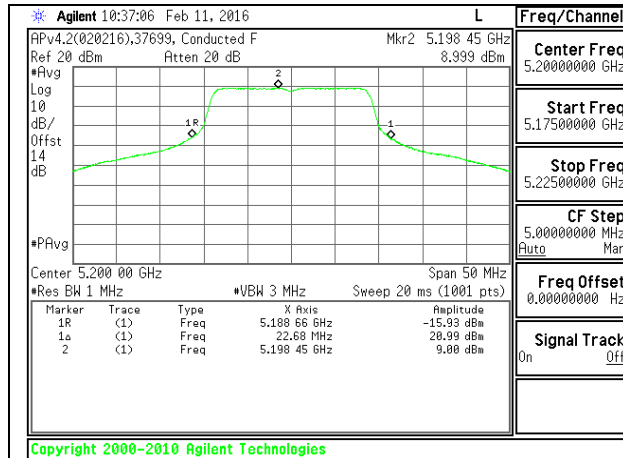

MID CHANNEL CHAIN 0

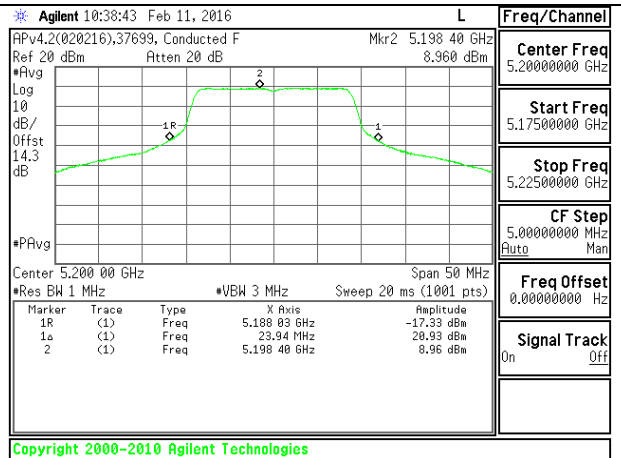

MID CHANNEL CHAIN 1

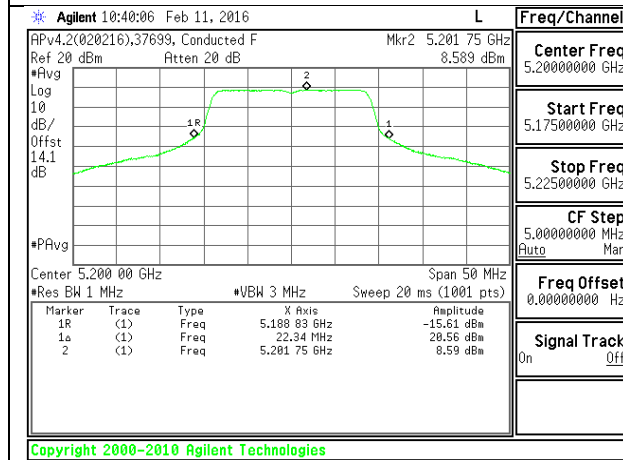

MID CHANNEL CHAIN 2

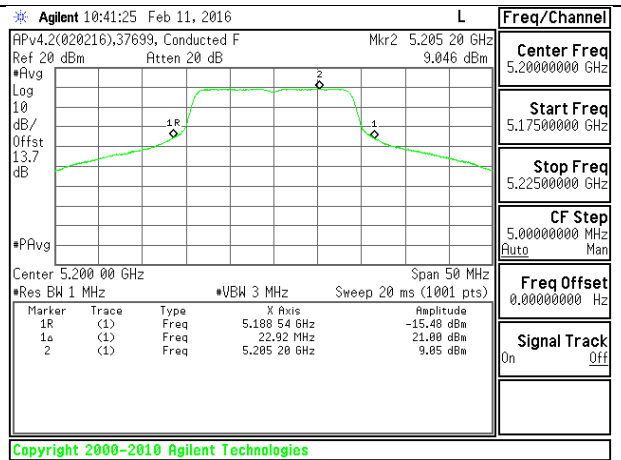

MID CHANNEL CHAIN 3

HIGH CHANNEL

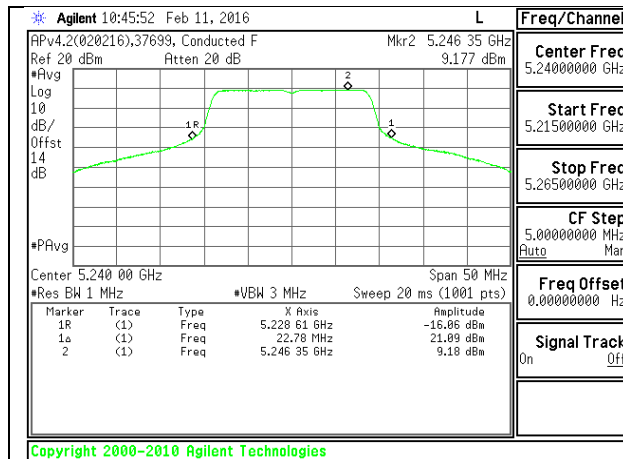

HIGH CHANNEL CHAIN 0

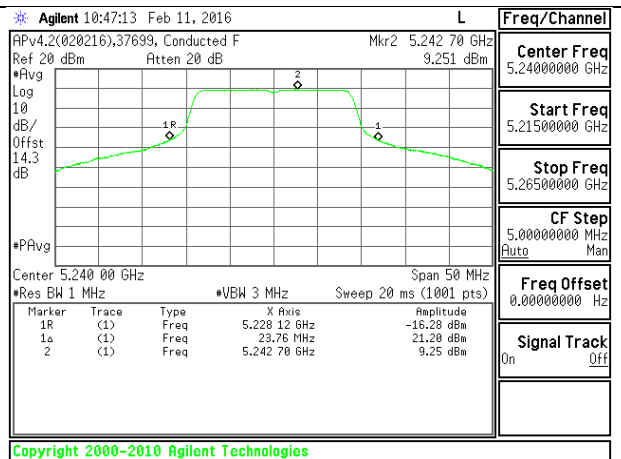

HIGH CHANNEL CHAIN 1

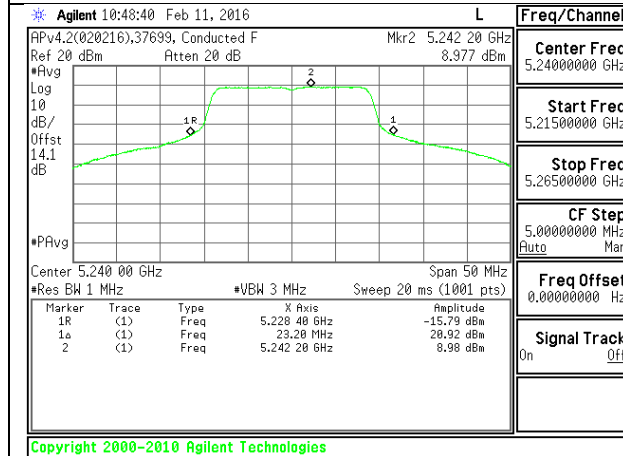

HIGH CHANNEL CHAIN 2

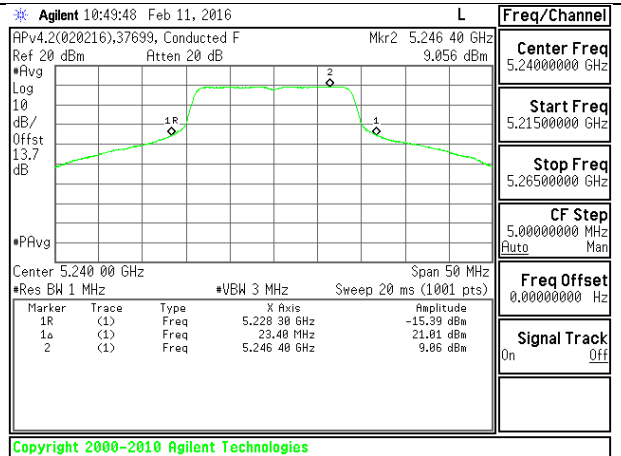

HIGH CHANNEL CHAIN 3

4Tx 1 STREAM CDD MODE

Antenna Gain and Limits

Channel	Frequency (MHz)	Directional Gain for Power (dBi)	Directional Gain for PSD (dBi)	Power Limit (dBm)	PSD Limit (dBm)
Low	5180	3.98	9.92	30.00	13.08
Mid	5200	3.98	9.92	30.00	13.08
High	5240	3.98	9.92	30.00	13.08

Duty Cycle CF (dB)	0.00	Included in Calculations of Corr'd Power & PSD
---------------------------	------	---

Output Power Results

Channel	Frequency (MHz)	Chain 0 Meas Power (dBm)	Chain 1 Meas Power (dBm)	Chain 2 Meas Power (dBm)	Chain 3 Meas Power (dBm)	Total Corr'd Power (dBm)	Power Limit (dBm)	Power Margin (dB)
Low	5180	18.81	18.59	18.73	18.54	24.69	30.00	-5.31
Mid	5200	18.93	18.80	18.85	18.23	24.73	30.00	-5.27
High	5240	19.20	18.79	18.80	18.60	24.87	30.00	-5.13

PSD Results

Channel	Frequency (MHz)	Chain 0 Meas PSD (dBm)	Chain 1 Meas PSD (dBm)	Chain 2 Meas PSD (dBm)	Chain 3 Meas PSD (dBm)	Total Corr'd PSD (dBm)	PSD Limit (dBm)	PSD Margin (dB)
Low	5180	6.87	6.67	6.92	6.70	12.81	13.08	-0.27
Mid	5200	6.95	6.87	6.92	6.29	12.78	13.08	-0.30
High	5240	7.32	6.89	6.98	6.73	13.01	13.08	-0.07

LOW CHANNEL

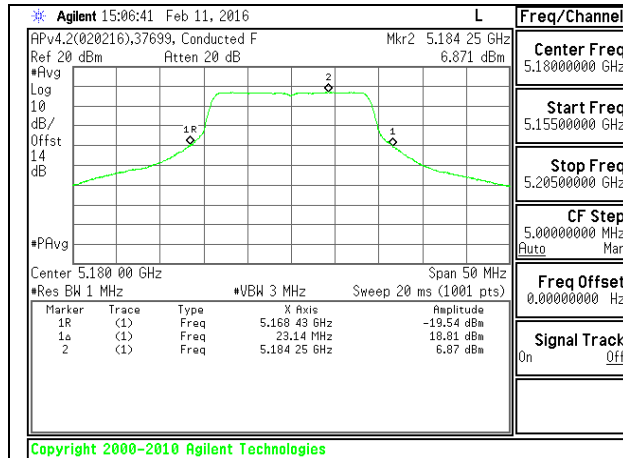

LOW CHANNEL CHAIN 0

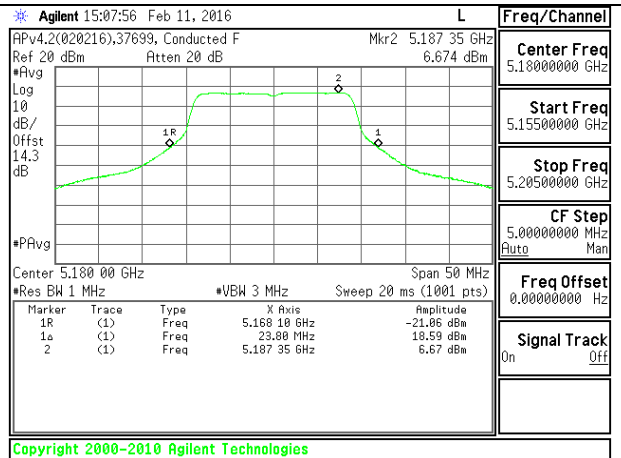

LOW CHANNEL CHAIN 1

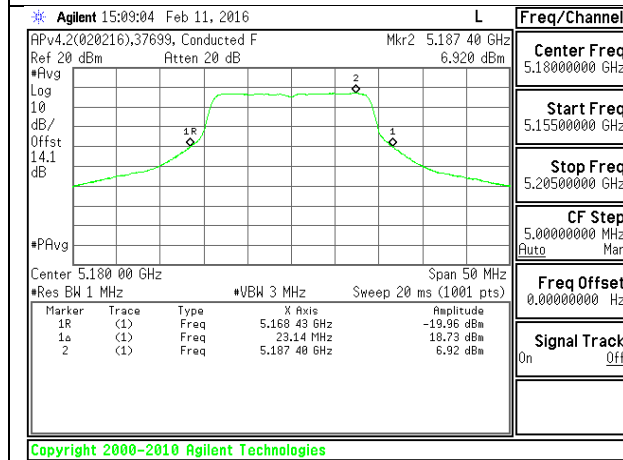

LOW CHANNEL CHAIN 2

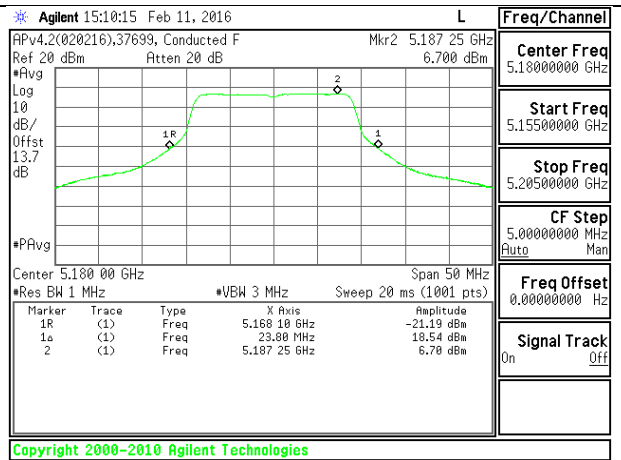

LOW CHANNEL CHAIN 3

MID CHANNEL

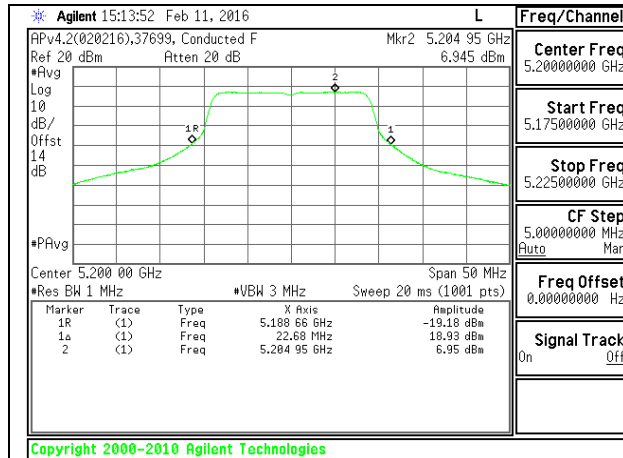

MID CHANNEL CHAIN 0

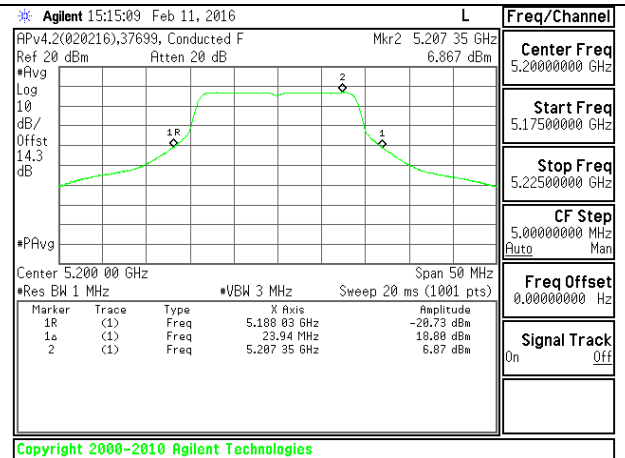

MID CHANNEL CHAIN 1

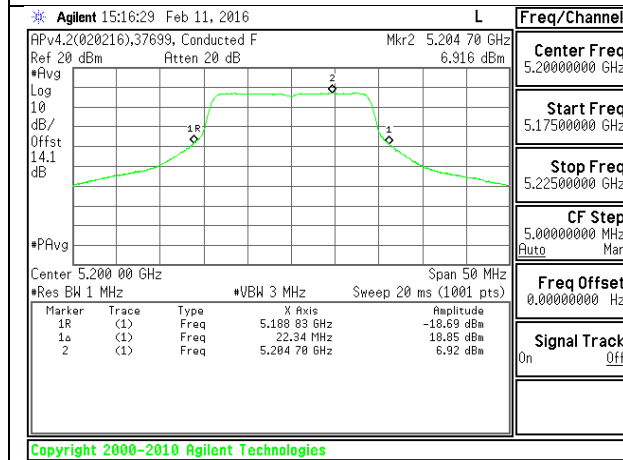

MID CHANNEL CHAIN 2

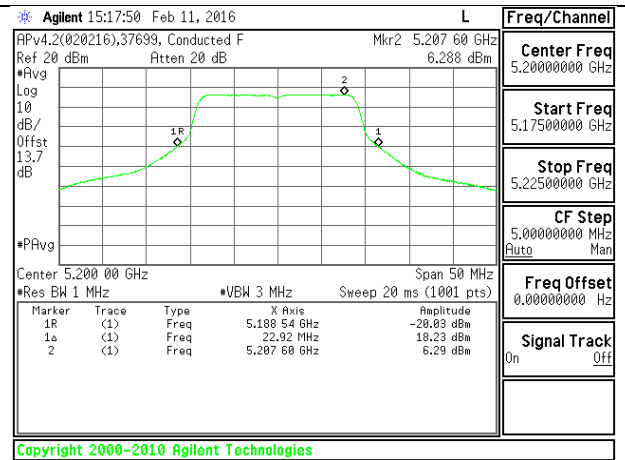

MID CHANNEL CHAIN 3

HIGH CHANNEL

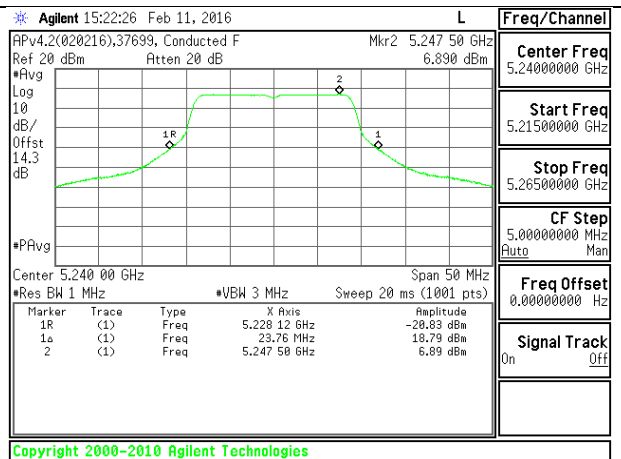
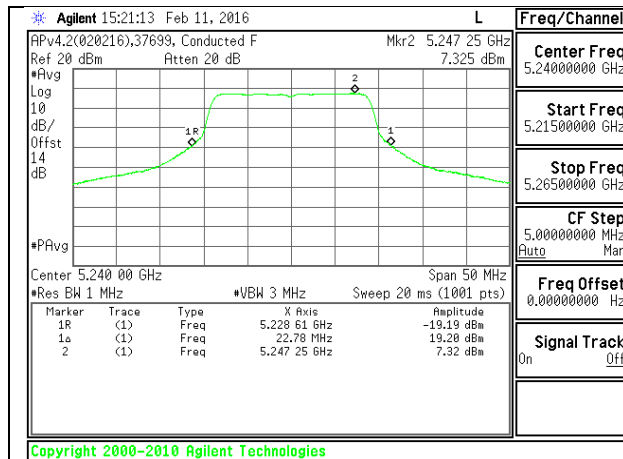

HIGH CHANNEL CHAIN 0

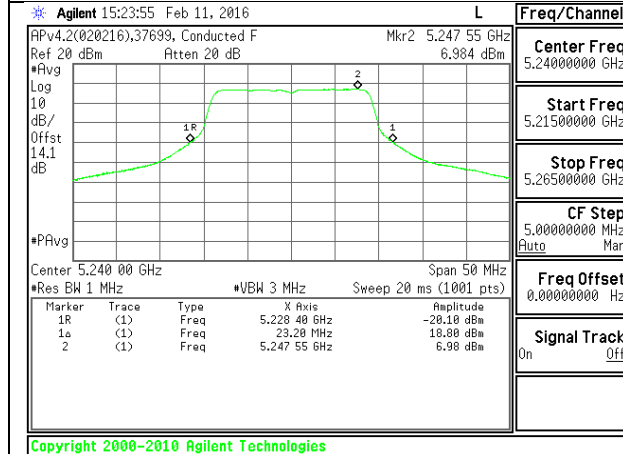

HIGH CHANNEL CHAIN 1

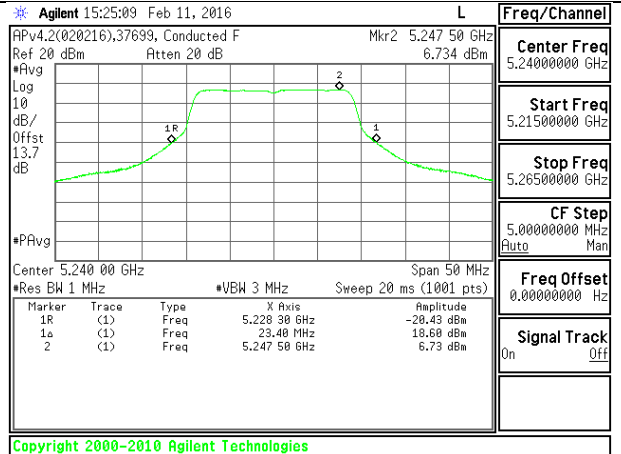

HIGH CHANNEL CHAIN 2

HIGH CHANNEL CHAIN 3

4Tx 3 STREAM BF MODE

Antenna Gain and Limits

Channel	Frequency (MHz)	Directional Gain for Power (dBi)	Directional Gain for PSD (dBi)	Power Limit (dBm)	PSD Limit (dBm)
Low	5180	6.03	6.03	29.97	16.97
Mid	5200	6.03	6.03	29.97	16.97
High	5240	6.03	6.03	29.97	16.97

Duty Cycle CF (dB)	0.49	Included in Calculations of Corr'd Power & PSD
---------------------------	------	---

Output Power Results

Channel	Frequency (MHz)	Chain 0 Meas Power (dBm)	Chain 1 Meas Power (dBm)	Chain 2 Meas Power (dBm)	Chain 3 Meas Power (dBm)	Total Corr'd Power (dBm)	Power Limit (dBm)	Power Margin (dB)
Low	5180	16.52	16.70	16.48	15.64	22.86	29.97	-7.11
Mid	5200	17.90	17.82	17.38	16.75	24.00	29.97	-5.97
High	5240	21.49	21.54	20.96	20.86	27.73	29.97	-2.24

PSD Results

Channel	Frequency (MHz)	Chain 0 Meas PSD (dBm)	Chain 1 Meas PSD (dBm)	Chain 2 Meas PSD (dBm)	Chain 3 Meas PSD (dBm)	Total Corr'd PSD (dBm)	PSD Limit (dBm)	PSD Margin (dB)
Low	5180	5.11	5.30	5.18	3.86	11.41	16.97	-5.56
Mid	5200	6.39	6.25	6.84	4.95	12.67	16.97	-4.30
High	5240	9.90	10.52	9.70	9.26	16.38	16.97	-0.59

LOW CHANNEL

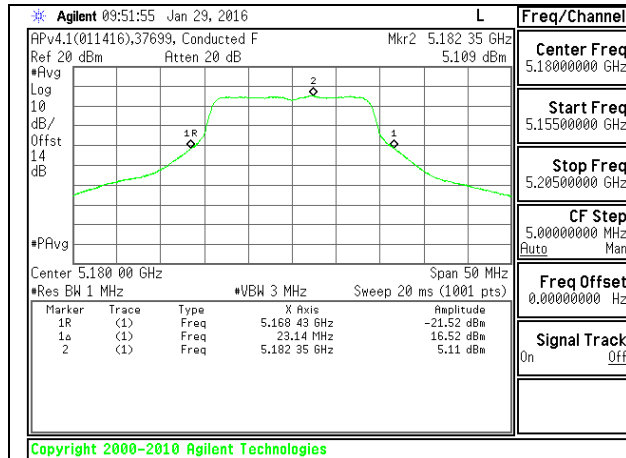

LOW CHANNEL CHAIN 0

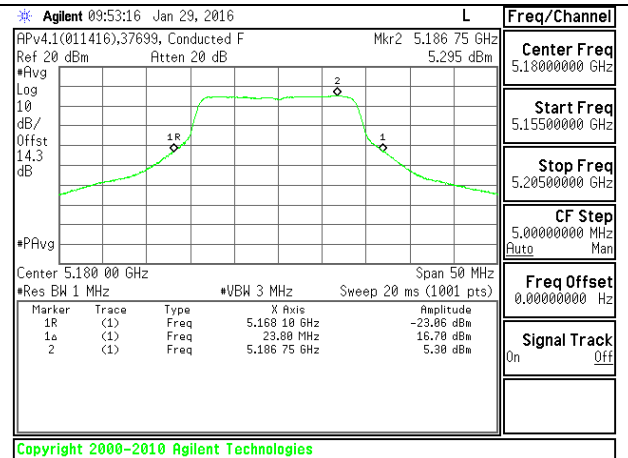

LOW CHANNEL CHAIN 1

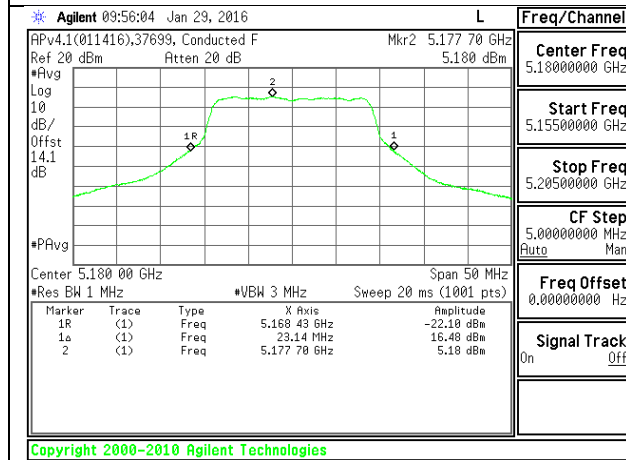

LOW CHANNEL CHAIN 2

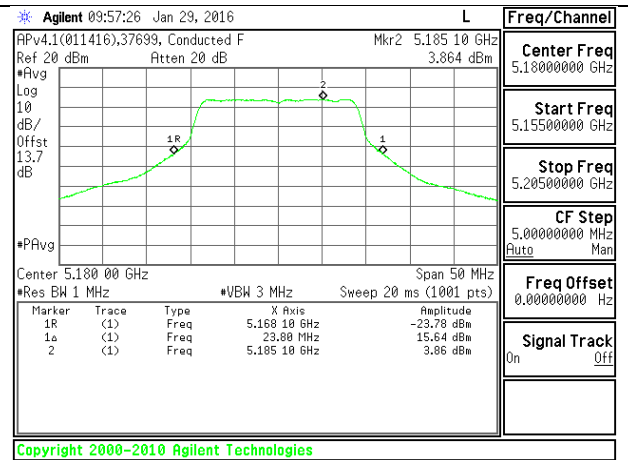

LOW CHANNEL CHAIN 3

MID CHANNEL

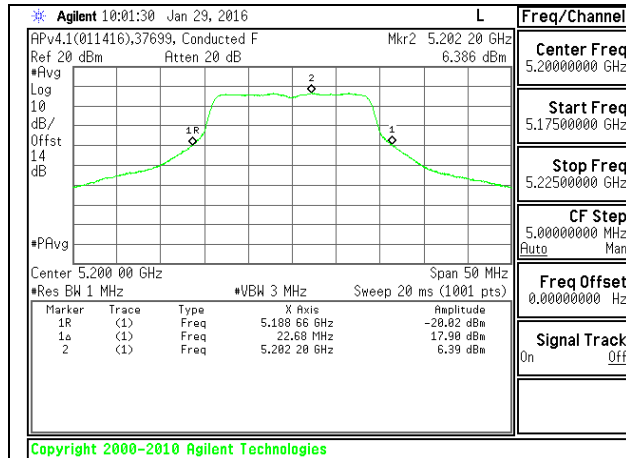

MID CHANNEL CHAIN 0

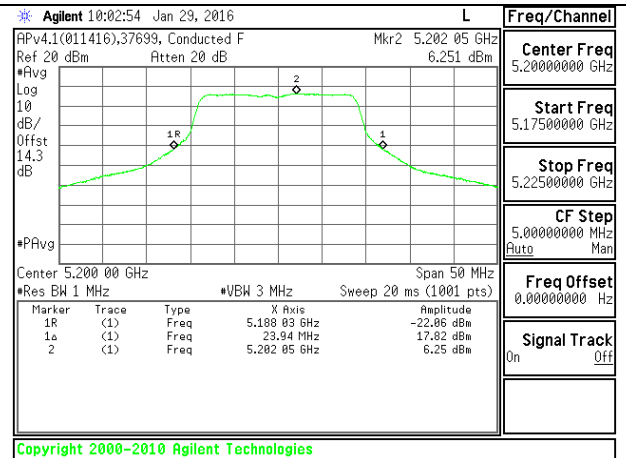

MID CHANNEL CHAIN 1

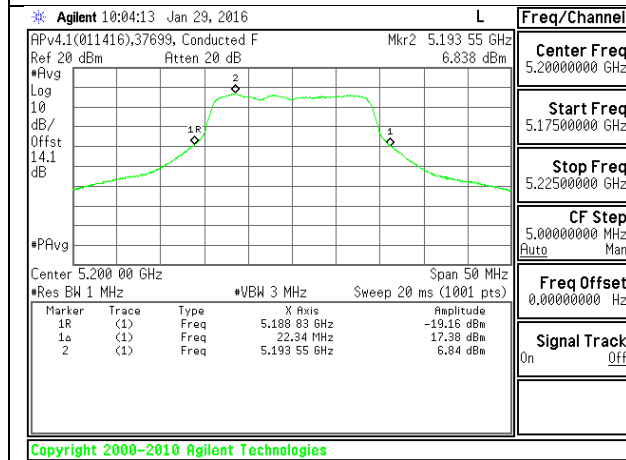

MID CHANNEL CHAIN 2

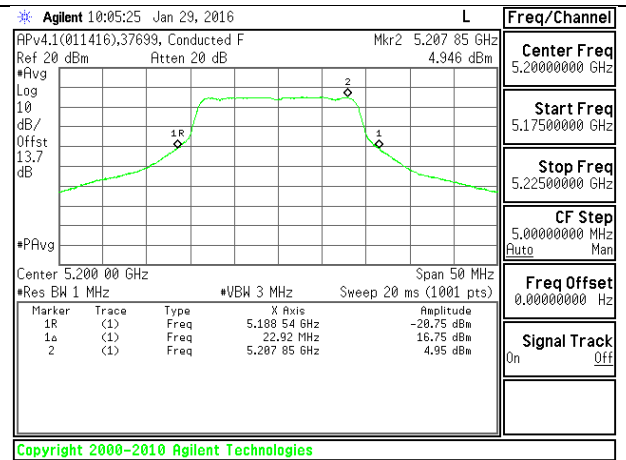

MID CHANNEL CHAIN 3

HIGH CHANNEL

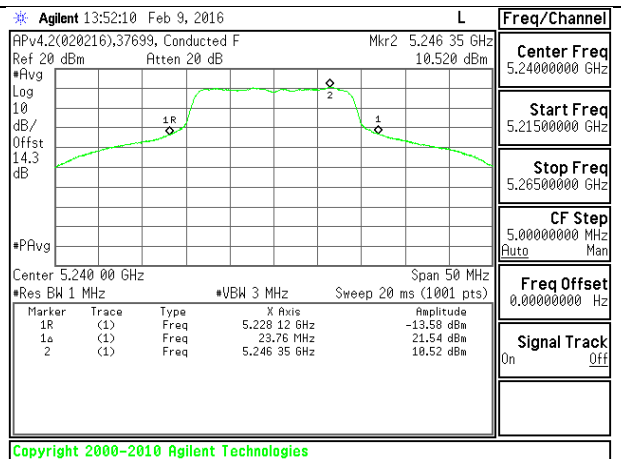
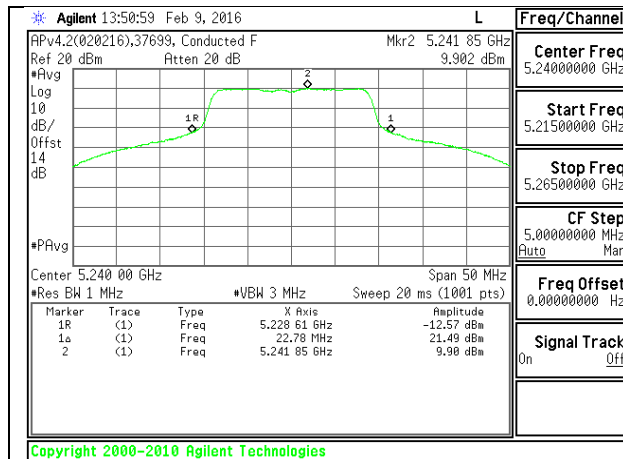

HIGH CHANNEL CHAIN 0

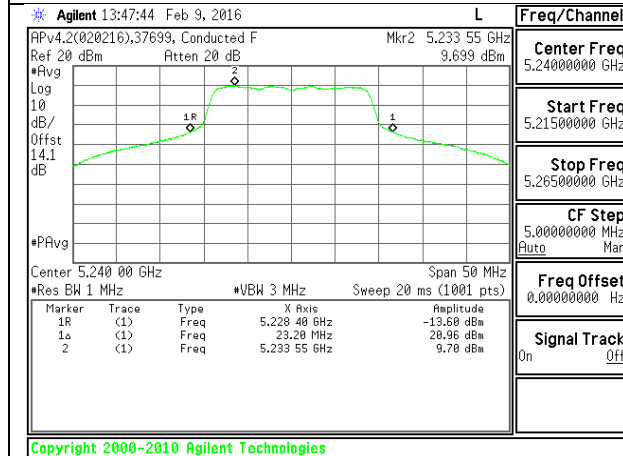

HIGH CHANNEL CHAIN 1

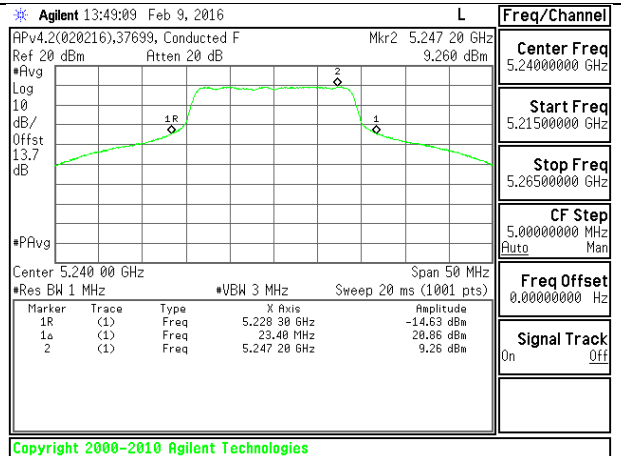

HIGH CHANNEL CHAIN 2

HIGH CHANNEL CHAIN 3

4Tx 1 STREAM BF MODE

Antenna Gain and Limits

Channel	Frequency (MHz)	Directional Gain for Power (dBi)	Directional Gain for PSD (dBi)	Power Limit (dBm)	PSD Limit (dBm)
Low	5180	9.92	9.92	26.08	13.08
Mid	5200	9.92	9.92	26.08	13.08
High	5240	9.92	9.92	26.08	13.08

Duty Cycle CF (dB)	0.68	Included in Calculations of Corr'd Power & PSD
---------------------------	------	---

Output Power Results

Channel	Frequency (MHz)	Chain 0 Meas Power (dBm)	Chain 1 Meas Power (dBm)	Chain 2 Meas Power (dBm)	Chain 3 Meas Power (dBm)	Total Corr'd Power (dBm)	Power Limit (dBm)	Power Margin (dB)
Low	5180	17.83	18.04	15.14	16.55	23.74	26.08	-2.34
Mid	5200	18.64	19.37	17.03	17.24	24.88	26.08	-1.20
High	5240	17.77	17.95	15.70	16.63	23.81	26.08	-2.27

PSD Results

Channel	Frequency (MHz)	Chain 0 Meas PSD (dBm)	Chain 1 Meas PSD (dBm)	Chain 2 Meas PSD (dBm)	Chain 3 Meas PSD (dBm)	Total Corr'd PSD (dBm)	PSD Limit (dBm)	PSD Margin (dB)
Low	5180	5.98	6.19	3.46	4.66	11.91	13.08	-1.17
Mid	5200	6.78	7.41	5.43	5.45	13.05	13.08	-0.03
High	5240	6.05	6.26	4.92	5.00	12.30	13.08	-0.78

LOW CHANNEL

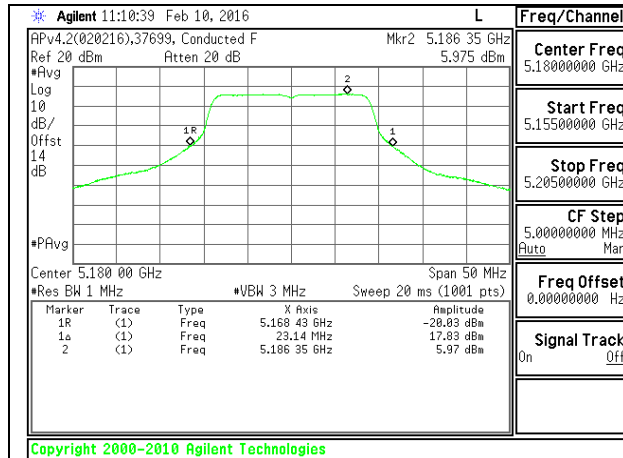

LOW CHANNEL CHAIN 0

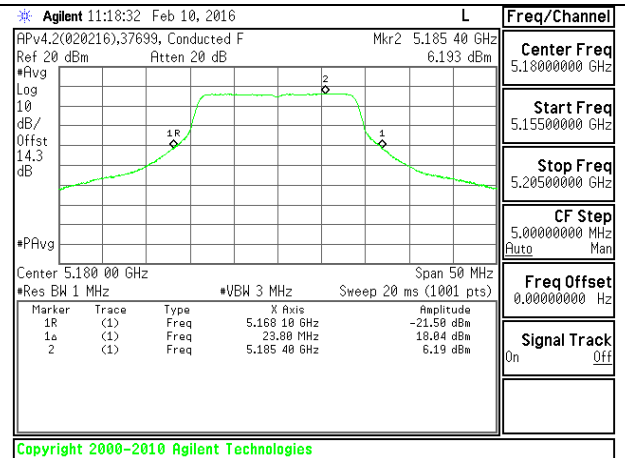

LOW CHANNEL CHAIN 1

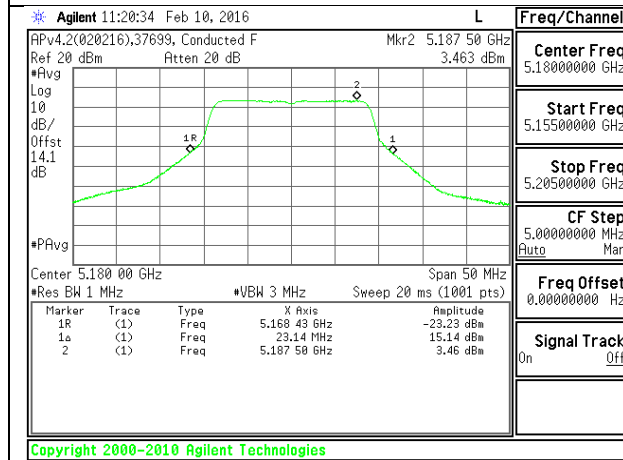

LOW CHANNEL CHAIN 2

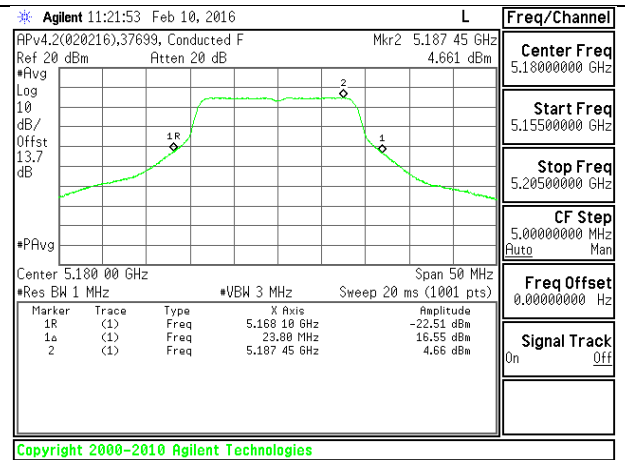

LOW CHANNEL CHAIN 3

MID CHANNEL

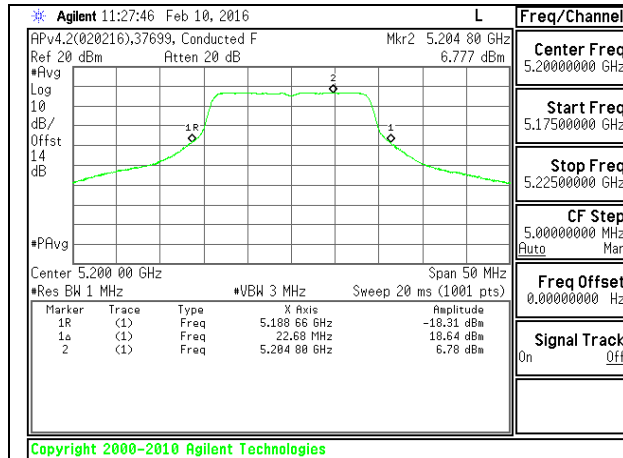

MID CHANNEL CHAIN 0

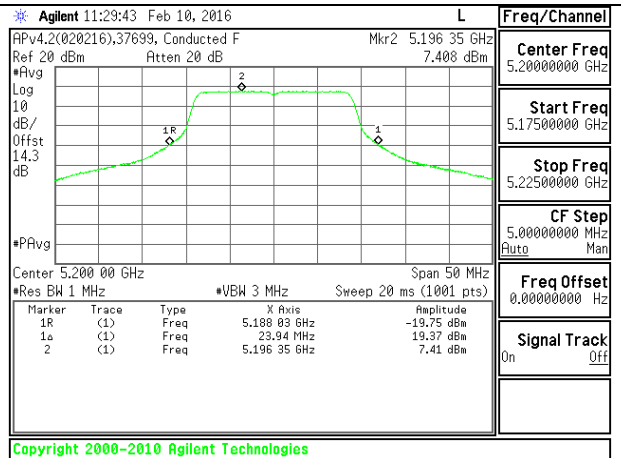

MID CHANNEL CHAIN 1

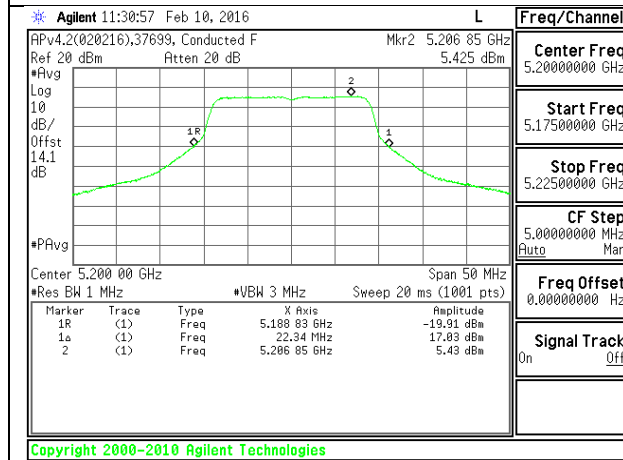

MID CHANNEL CHAIN 2

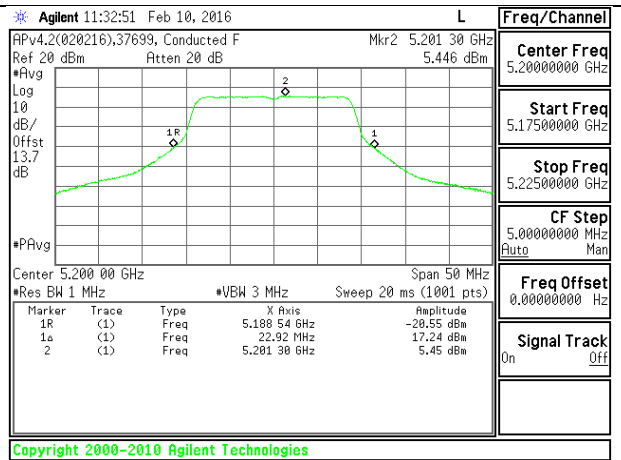

MID CHANNEL CHAIN 3

HIGH CHANNEL

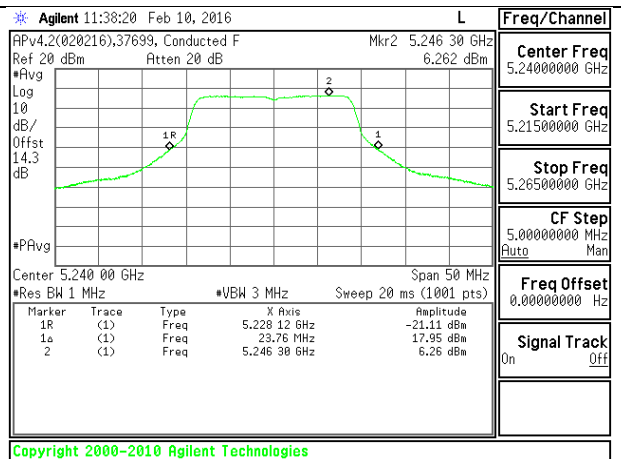
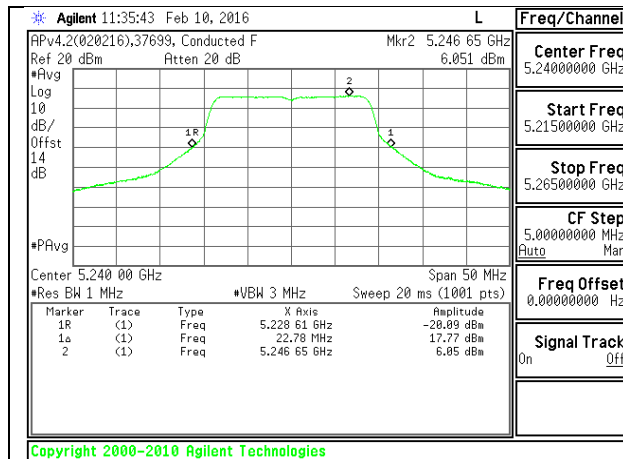

HIGH CHANNEL CHAIN 0

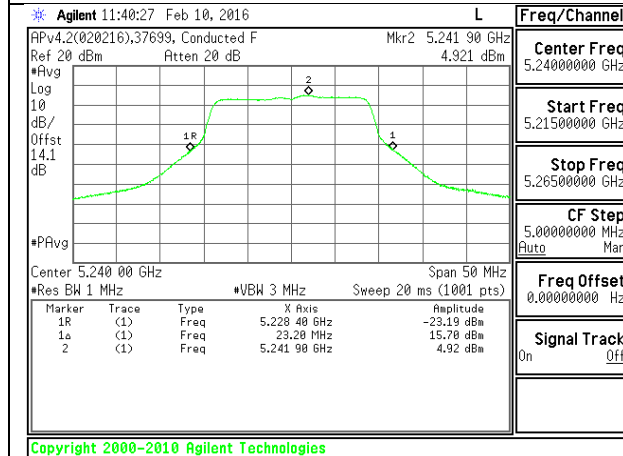

HIGH CHANNEL CHAIN 2

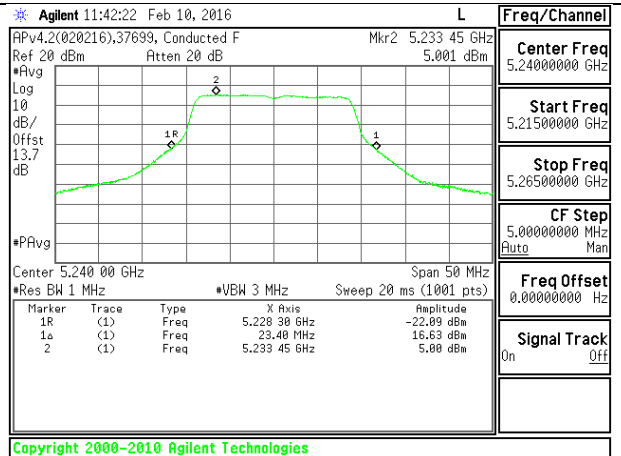

HIGH CHANNEL CHAIN 3