



FCC RADIO TEST REPORT

FCC ID : A4RGR83Y
Equipment : Phone
Model Name : GR83Y
Applicant : Google LLC
1600 Amphitheatre Parkway,
Mountain View, CA 94043 USA
Standard : FCC Part 15 Subpart C §15.247

The product was received on Dec. 20, 2023 and testing was performed from Jan. 11, 2024 to Mar. 28, 2024. We, Sporton International Inc. Wensan Laboratory, would like to declare that the tested sample has been evaluated in accordance with the test procedures and has been in compliance with the applicable technical standards.

The test results in this report apply exclusively to the tested model / sample. Without written approval from Sporton International Inc. Wensan Laboratory, the test report shall not be reproduced except in full.

Approved by: Louis Wu

Sporton International Inc. Wensan Laboratory

No.58, Aly. 75, Ln. 564, Wenhua 3rd, Rd., Guishan Dist., Taoyuan City 333010, Taiwan (R.O.C.)



Table of Contents

History of this test report..... 3

Summary of Test Result..... 4

1 General Description..... 5

 1.1 Product Feature of Equipment Under Test..... 5

 1.2 Modification of EUT 5

 1.3 Testing Location 6

 1.4 Applicable Standards..... 6

2 Test Configuration of Equipment Under Test 7

 2.1 Carrier Frequency Channel 7

 2.2 Test Mode..... 8

 2.3 Connection Diagram of Test System..... 9

 2.4 Support Unit used in test configuration and system 10

 2.5 EUT Operation Test Setup 10

 2.6 Measurement Results Explanation Example..... 10

3 Test Result..... 11

 3.1 6dB and 99% Bandwidth Measurement 11

 3.2 Output Power Measurement..... 12

 3.3 Power Spectral Density Measurement 13

 3.4 Conducted Band Edges and Spurious Emission Measurement 14

 3.5 Radiated Band Edges and Spurious Emission Measurement 15

 3.6 AC Conducted Emission Measurement..... 19

 3.7 Antenna Requirements 21

4 List of Measuring Equipment 22

5 Measurement Uncertainty 24

Appendix A. Conducted Test Results

Appendix B. AC Conducted Emission Test Result

Appendix C. Radiated Spurious Emission

Appendix D. Radiated Spurious Emission Plots

Appendix E. Duty Cycle Plots

Appendix F. Setup Photographs



Summary of Test Result

Report Clause	Ref Std. Clause	Test Items	Result (PASS/FAIL)	Remark
3.1	15.247(a)(2)	6dB Bandwidth	Pass	-
3.1	2.1049	99% Occupied Bandwidth	Reporting only	-
3.2	15.247(b)(3) 15.247(b)(4)	Output Power	Pass	-
3.3	15.247(e)	Power Spectral Density	Pass	-
3.4	15.247(d)	Conducted Band Edges and Spurious Emission	Pass	-
3.5	15.247(d)	Radiated Band Edges and Spurious Emission	Pass	6.59 dB under the limit at 51.78 MHz
3.6	15.207	AC Conducted Emission	Pass	6.79 dB under the limit at 0.18 MHz
3.7	15.203	Antenna Requirement	Pass	-

Conformity Assessment Condition:

1. The test results (PASS/FAIL) with all measurement uncertainty excluded are presented against the regulation limits or in accordance with the requirements stipulated by the applicant/manufacturer who shall bear all the risks of non-compliance that may potentially occur if measurement uncertainty is taken into account.
2. The measurement uncertainty please refer to each test result in the section "Measurement Uncertainty".

Disclaimer:

The product specifications of the EUT presented in the test report that may affect the test assessments are declared by the manufacturer who shall take full responsibility for the authenticity.

Reviewed by: William Chen
Report Producer: Mila Chen



1 General Description

1.1 Product Feature of Equipment Under Test

Product Feature
<p>General Specs GSM/WCDMA/LTE/5G NR, Bluetooth, BLE, BLE channel sounding, Thread, Wi-Fi 802.11be, UWB, NFC, WPT, NTN and GNSS.</p> <p>Antenna Type Thread: <Ant. 3>: PIFA Antenna</p>

EUT Information List	
S/N	Performed Test Item
41101FDAP0002H	RF Conducted Measurement
3B131FDAP0007E	Radiated Spurious Emission
3B131FDAP0007E	Conducted Emission

Antenna information		
2400 MHz ~ 2483.5 MHz	Peak Gain (dBi)	-0.1

Remark: The EUT's information above is declared by manufacturer. Please refer to Disclaimer in report summary.

1.2 Modification of EUT

No modifications made to the EUT during the testing.



1.3 Testing Location

Test Site	Sporton International Inc. Wensan Laboratory
Test Site Location	No.58, Aly. 75, Ln. 564, Wenhua 3rd, Rd., Guishan Dist., Taoyuan City 333010, Taiwan (R.O.C.) TEL: +886-3-327-0868 FAX: +886-3-327-0855
Test Site No.	Sporton Site No.
	TH05-HY, CO07-HY, 03CH15-HY

Note: The test site complies with ANSI C63.4 2014 requirement.

FCC designation No.: TW3786

1.4 Applicable Standards

According to the specifications declared by the manufacturer, the EUT must comply with the requirements of the following standards:

- ♦ FCC Part 15 Subpart C §15.247
- ♦ FCC KDB Publication No. 558074 D01 15.247 Meas Guidance v05r02
- ♦ FCC KDB 414788 D01 Radiated Test Site v01r01
- ♦ ANSI C63.10-2013

Remark:

1. All the test items were validated and recorded in accordance with the standards without any modification during the testing.
2. The TAF code is not including all the FCC KDB listed without accreditation.



2 Test Configuration of Equipment Under Test

2.1 Carrier Frequency Channel

Frequency Band	Channel	Freq. (MHz)	Channel	Freq. (MHz)
2400-2483.5 MHz	11	2405	19	2445
	12	2410	20	2450
	13	2415	21	2455
	14	2420	22	2460
	15	2425	23	2465
	16	2430	24	2470
	17	2435	25	2475
	18	2440	26	2480



2.2 Test Mode

- a. The EUT has been associated with peripherals and configuration operated in a manner tended to maximize its emission characteristics in a typical application. Frequency range investigated: conduction emission (150 kHz to 30 MHz), radiation emission (9 kHz to the 10th harmonic of the highest fundamental frequency or to 40 GHz, whichever is lower). For radiated measurement, the measured emission level of the EUT was maximized by rotating the EUT on a turntable, adjusting the orientation of the EUT and EUT antenna in three orthogonal axis (X: flat, Y: portrait, Z: landscape) and accessory (Adapter or Earphone), and adjusting the measurement antenna orientation, following C63.10 exploratory test procedures and find X Plane with Adapter as worst plane.
- b. AC power line Conducted Emission was tested under maximum output power.

The following summary table is showing all test modes to demonstrate in compliance with the standard.

Summary table of Test Cases	
Test Item	Data Rate / Modulation
Conducted Test Cases	Bluetooth – LE / GFSK
	Mode 1: Thread Tx CH11_2405 MHz
	Mode 2: Thread Tx CH18_2440 MHz
	Mode 3: Thread Tx CH25_2475 MHz
	Mode 4: Thread Tx CH26_2480 MHz
Radiated Test Cases	Mode 1: Thread Tx CH11_2405 MHz
	Mode 2: Thread Tx CH18_2440 MHz
	Mode 3: Thread Tx CH25_2475 MHz
	Mode 4: Thread Tx CH26_2480 MHz
	AC Conducted Emission
Remark:	
<ol style="list-style-type: none"> 1. For Radiated Test Cases, the tests were performed with Adapter 1 and USB Cable 2. 2. During the preliminary test, both charging modes (Adapter mode and WPT Charging mode) were verified. It is determined that the adaptor mode is the worst case for official test. 3. For radiation spurious emission, the modulation and the data rate picked for testing are determined by the Max. RF conducted power. 	

2.3 Connection Diagram of Test System

<AC Conducted Emission Mode>

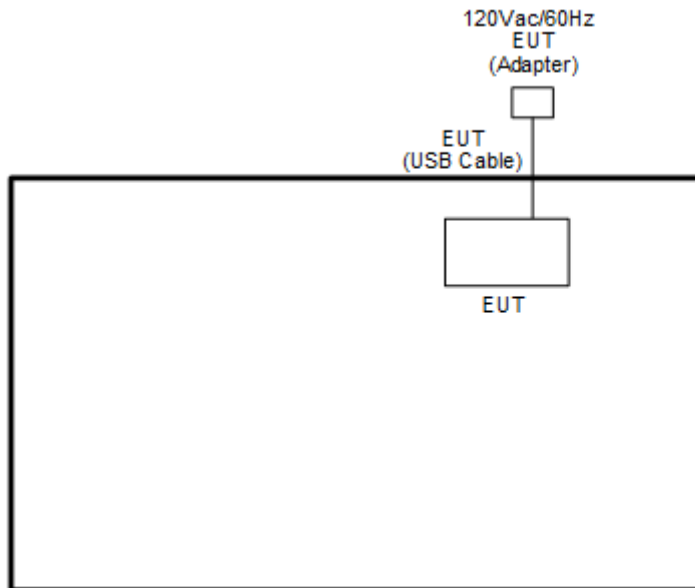

< Radiated Emission Mode>

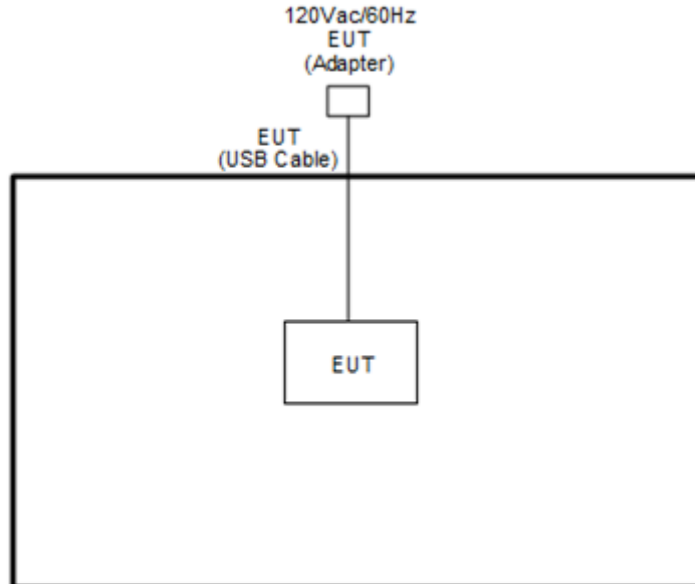



2.4 Support Unit used in test configuration and system

Item	Equipment	Brand Name	Model Name	FCC ID	Data Cable	Power Cord
1.	Notebook	DELL	Latitude 3400	FCC DoC	N/A	AC I/P: Unshielded, 1.2 m DC O/P: Shielded, 1.8 m

2.5 EUT Operation Test Setup

The RF test items, utility “BT_DUT_Control_GUI_03-11-24.exe” was installed in Notebook which was programmed in order to make the EUT get into the engineering modes to provide channel selection, power level, data rate and the application type and for continuous transmitting signals.

2.6 Measurement Results Explanation Example

For all conducted test items:

The offset level is set in the spectrum analyzer to compensate the RF cable loss and attenuator factor between EUT conducted output port and spectrum analyzer. With the offset compensation, the spectrum analyzer reading level is exactly the EUT RF output level.

Example :

The spectrum analyzer offset is derived from RF cable loss and attenuator factor.

Offset = RF cable loss + attenuator factor.

Following shows an offset computation example with cable loss 4.2 dB and 10 dB attenuator.

$$\begin{aligned} \text{Offset(dB)} &= \text{RF cable loss(dB)} + \text{attenuator factor(dB)}. \\ &= 4.2 + 10 = 14.2 \text{ (dB)} \end{aligned}$$

3 Test Result

3.1 6dB and 99% Bandwidth Measurement

3.1.1 Limit of 6dB and 99% Bandwidth

The minimum 6 dB bandwidth shall be at least 500 kHz.

3.1.2 Measuring Instruments

Please refer to the measuring equipment list in this test report.

3.1.3 Test Procedures

1. The testing follows the ANSI C63.10 Section 6.9.3 (OBW) and 11.8.1 (6dB BW).
2. The RF output of EUT is connected to the spectrum analyzer by RF cable and attenuator. The path loss is compensated to the results for each measurement.
3. Set the maximum power setting and enable the EUT to transmit continuously.
4. Make the measurement with the spectrum analyzer's resolution bandwidth (RBW) = 100 kHz. Set the Video bandwidth (VBW) = 300 kHz. In order to make an accurate measurement. The 6dB bandwidth must be greater than 500 kHz.
5. For 99% Bandwidth Measurement, the spectrum analyzer's resolution bandwidth (RBW) is set 1-5% of the emission bandwidth and set the Video bandwidth (VBW) $\geq 3 * RBW$.
6. Measure and record the results in the test report.

3.1.4 Test Setup



3.1.5 Test Result of 6dB Bandwidth

Please refer to Appendix A.

3.1.6 Test Result of 99% Occupied Bandwidth

Please refer to Appendix A.

3.2 Output Power Measurement

3.2.1 Limit of Output Power

For systems using digital modulation in the 2400-2483.5 MHz, the limit for output power is 30 dBm. If transmitting antenna of directional gain greater than 6 dBi is used, the peak output power from the intentional radiator shall be reduced below the above stated value by the amount in dB that the directional gain of the antenna exceeds 6 dBi. In case of point-to-point operation, the limit has to be reduced by 1 dB for every 3 dB that the directional gain of the antenna exceeds 6 dBi.

3.2.2 Measuring Instruments

Please refer to the measuring equipment list in this test report.

3.2.3 Test Procedures

1. For Peak Power, the testing follows ANSI C63.10 Section 11.9.1.3 PKPM1.
2. For Average Power, the testing follows ANSI C63.10 Section 11.9.2.3.2 Method AVGPM-G
3. The RF output of EUT is connected to the power meter by RF cable and attenuator.
4. The path loss is compensated to the results for each measurement.
5. Set the maximum power setting and enable the EUT to transmit continuously.
6. Measure the conducted output power and record the results in the test report.

3.2.4 Test Setup

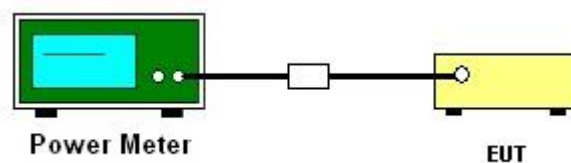

3.2.5 Test Result of Peak Output Power

Please refer to Appendix A.

3.2.6 Test Result of Average Output Power (Reporting Only)

Please refer to Appendix A.

3.3 Power Spectral Density Measurement

3.3.1 Limit of Power Spectral Density

The peak power spectral density shall not be greater than 8 dBm in any 3 kHz band at any time interval of continuous transmission.

3.3.2 Measuring Instruments

Please refer to the measuring equipment list in this test report.

3.3.3 Test Procedures

1. The testing follows the ANSI C63.10 Section 11.10.2 Method PKPSD.
2. The RF output of EUT is connected to the spectrum analyzer by RF cable and attenuator. The path loss is compensated to the results for each measurement.
3. Set the maximum power setting and enable the EUT to transmit continuously.
4. Make the measurement with the spectrum analyzer's resolution bandwidth (RBW) = 3 kHz. Video bandwidth (VBW) = 10 kHz. In order to make an accurate measurement, set the span to 1.5 times DTS Channel Bandwidth. (6 dB BW)
5. Detector = peak, Sweep time = auto couple, Trace mode = max hold, Allow trace to fully stabilize. Use the peak marker function to determine the maximum power level.
6. Measure and record the results in the test report.
7. The Measured power density (dBm)/ 100 kHz is a reference level and is used as 20 dBc down limit line for Conducted Band Edges and Conducted Spurious Emission.

3.3.4 Test Setup

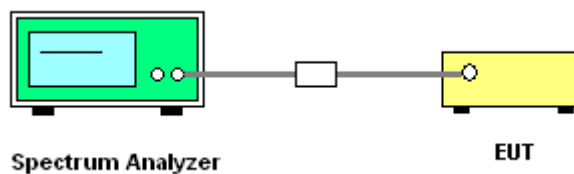

3.3.5 Test Result of Power Spectral Density

Please refer to Appendix A.

3.4 Conducted Band Edges and Spurious Emission Measurement

3.4.1 Limit of Conducted Band Edges and Spurious Emission

All harmonics/spurious must be at least 20 dB down from the highest emission level within the authorized band.

3.4.2 Measuring Instruments

Please refer to the measuring equipment list in this test report.

3.4.3 Test Procedure

1. The testing follows the ANSI C63.10 Section 11.11.3 Emission level measurement.
2. The RF output of EUT is connected to the spectrum analyzer by RF cable and attenuator. The path loss is compensated to the results for each measurement.
3. Set the maximum power setting and enable the EUT to transmit continuously.
4. Set RBW = 100 kHz, VBW = 300 kHz, Peak Detector. Unwanted Emissions measured in any 100 kHz bandwidth outside of the authorized frequency band shall be attenuated by at least 20 dB relative to the maximum in-band peak PSD level in 100 kHz when maximum peak conducted output power procedure is used. If the transmitter complies with the conducted power limits based on the use of RMS averaging over a time interval, the attenuation required under this paragraph shall be 30 dB instead of 20 dB.
5. Measure and record the results in the test report.
6. The RF fundamental frequency should be excluded against the limit line in the operating frequency band.

3.4.4 Test Setup

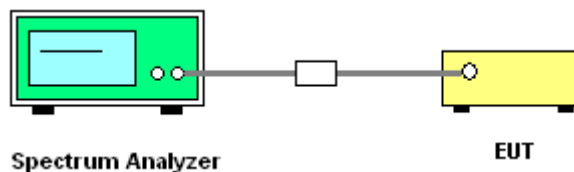

3.4.5 Test Result of Conducted Band Edges Plots

Please refer to Appendix A.

3.4.6 Test Result of Conducted Spurious Emission Plots

Please refer to Appendix A.



3.5 Radiated Band Edges and Spurious Emission Measurement

3.5.1 Limit of Radiated Band Edges and Spurious Emission

In any 100 kHz bandwidth outside the intentional radiator frequency band, all harmonics/spurious must be at least 20 dB below the highest emission level within the authorized band. If the output power of this device is measured by spectrum analyzer, the attenuation under this paragraph shall be 30 dB instead of 20 dB. In addition, radiated emissions which fall in the restricted bands must also comply with the limits as below.

Frequency (MHz)	Field Strength (microvolts/meter)	Measurement Distance (meters)
0.009 – 0.490	2400/F(kHz)	300
0.490 – 1.705	24000/F(kHz)	30
1.705 – 30.0	30	30
30 – 88	100	3
88 – 216	150	3
216 - 960	200	3
Above 960	500	3

3.5.2 Measuring Instruments

Please refer to the measuring equipment list in this test report.



3.5.3 Test Procedures

1. The testing follows the ANSI C63.10 Section 11.12.1 Radiated emission measurements.
2. The EUT is arranged to its worst case and then tune the antenna tower (from 1 m to 4 m) and turntable (from 0 degree to 360 degrees) to find the maximum reading. A pre-amp and a high pass filter are used for the test in order to get better signal level.
3. The EUT is placed on a turntable with 0.8 meter for frequency below 1 GHz and 1.5 meter for frequency above 1 GHz respectively above ground.
4. The EUT is set 3 meters away from the receiving antenna, which is mounted on the top of a variable height antenna tower.
5. Corrected Reading: Antenna Factor + Cable Loss + Read Level - Preamp Factor = Level
6. Radiated testing below 1 GHz is performed by adjusting the antenna tower from 1 m to 4 m and by rotating the turn table from 0 degree to 360 degrees to find the peak maximum hold reading. When there is no suspected emission found and the emission level is with at least 6 dB margin against QP limit line, the position is marked as “-“.
7. Radiated testing above 1 GHz is performed by adjusting the antenna tower from 1 m to 4 m and by rotating the turn table from 0 degree to 360 degrees to find the peak maximum hold reading for scanning all frequencies. When there is no suspected emission found and the harmonic emission level is with at least 6 dB margin against average limit line, the position is marked as “-“.
8. Use the following spectrum analyzer settings:
 - (1) Span shall wide enough to fully capture the emission being measured;
 - (2) Set RBW = 100 kHz for $f < 1$ GHz; VBW \geq RBW; Sweep = auto; Detector function = peak; Trace = max hold;
 - (3) Set RBW = 1 MHz, VBW = 3 MHz for $f \geq 1$ GHz for peak measurement.
For average measurement:
 - VBW = 10 Hz, when duty cycle is no less than 98 percent.
 - VBW $\geq 1/T$, when duty cycle is less than 98 percent where T is the minimum transmission duration over which the transmitter is on and is transmitting at its maximum power control level for the tested mode of operation.

3.5.4 Test Setup

For radiated test below 30MHz

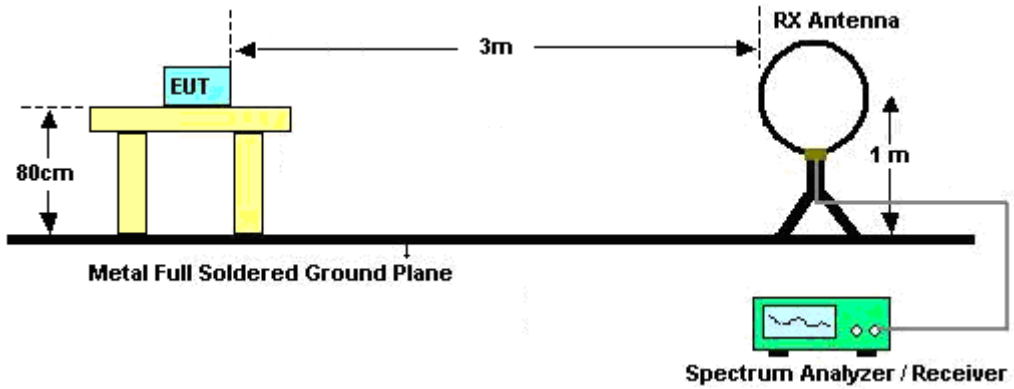

For radiated test from 30MHz to 1GHz

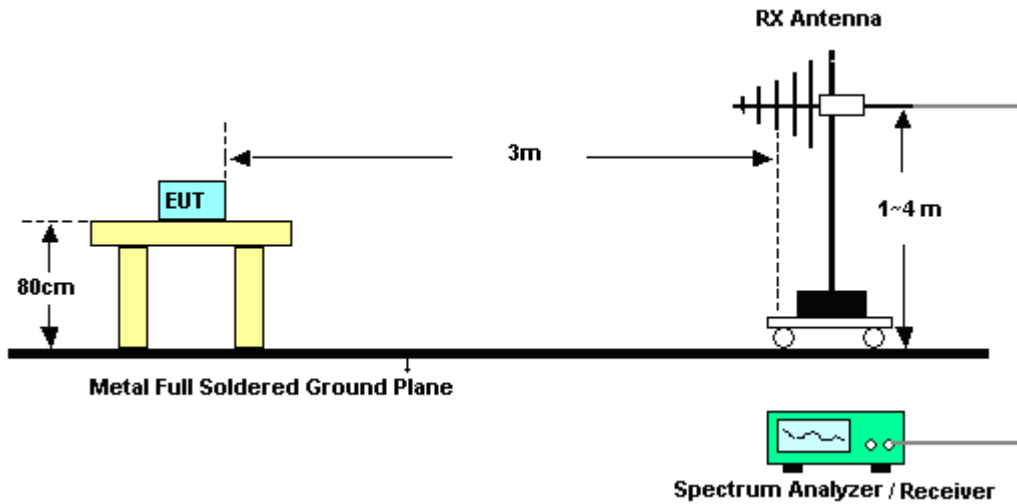

For radiated test from 1GHz to 18GHz

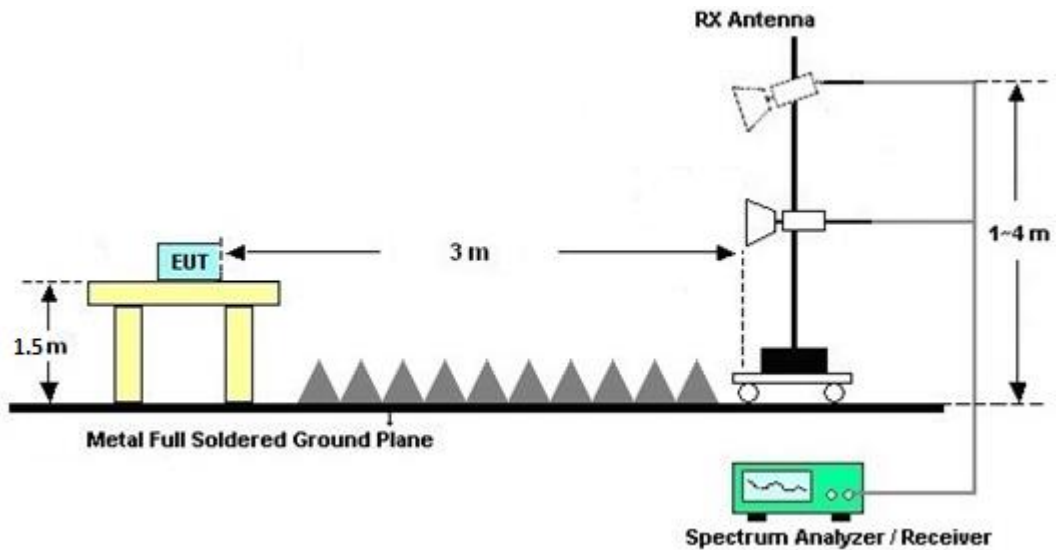

For radiated test above 18GHz

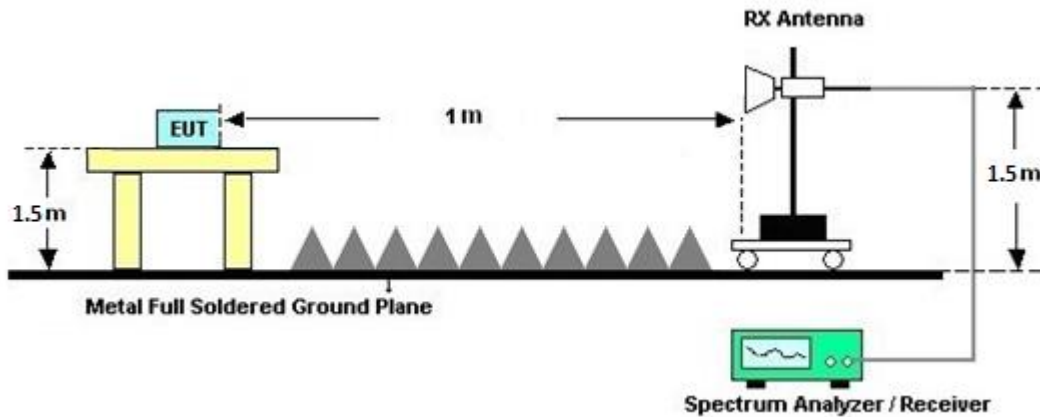

3.5.5 Test Results of Radiated Spurious Emissions (9 kHz ~ 30 MHz)

The low frequency, which starts from 9 kHz to 30 MHz, is pre-scanned and the result which is 20 dB lower than the limit line is not reported.

There is adequate comparison measurement of both open-field test site and alternative test site - semi-Anechoic chamber according to 414788 D01 Radiated Test Site v01r01, and the result comes out very similar.

3.5.6 Test Result of Radiated Spurious at Band Edges

Please refer to Appendix C and D.

3.5.7 Duty Cycle

Please refer to Appendix E.

3.5.8 Test Result of Radiated Spurious Emission (30 MHz ~ 10th Harmonic)

Please refer to Appendix C and D.



3.6 AC Conducted Emission Measurement

3.6.1 Limit of AC Conducted Emission

For equipment that is designed to be connected to the public utility (AC) power line, the radio frequency voltage that is conducted back onto the AC power line on any frequency or frequencies within the band 150 kHz to 30 MHz shall not exceed the limits in the following table.

Frequency of emission (MHz)	Conducted limit (dB μ V)	
	Quasi-peak	Average
0.15-0.5	66 to 56*	56 to 46*
0.5-5	56	46
5-30	60	50

*Decreases with the logarithm of the frequency.

3.6.2 Measuring Instruments

Please refer to the measuring equipment list in this test report.

3.6.3 Test Procedures

1. The EUT is placed 0.4 meter away from the conducting wall of the shielding room, and is kept at least 80 centimeters from any other grounded conducting surface.
2. Connect EUT to the power mains through a line impedance stabilization network (LISN).
3. All the support units are connecting to the other LISN.
4. The LISN provides 50 ohm coupling impedance for the measuring instrument.
5. The FCC states that a 50 ohm, 50 microhenry LISN shall be used.
6. Both Line and Neutral shall be tested in order to find out the maximum conducted emission.
7. The frequency range from 150 kHz to 30 MHz is scanned.
8. Set the test-receiver system to Peak Detect Function and specified bandwidth (IF Bandwidth = 9 kHz) with Maximum Hold Mode. Then measurement is also conducted by Average Detector and Quasi-Peak Detector Function respectively.

3.6.4 Test Setup



3.6.5 Test Result of AC Conducted Emission

Please refer to Appendix B.



3.7 Antenna Requirements

3.7.1 Standard Applicable

The use of a permanently attached antenna or of an antenna that uses a unique coupling to the intentional radiator shall be considered sufficient to comply with the rule.

3.7.2 Antenna Anti-Replacement Construction

An embedded-in antenna design is used.



4 List of Measuring Equipment

Instrument	Brand Name	Model No.	Serial No.	Characteristics	Calibration Date	Test Date	Due Date	Remark
AC Power Source	ACPOWER	AFC-11003G	F317040033	N/A	N/A	Mar. 23, 2024	N/A	Conduction (CO07-HY)
Software	Rohde & Schwarz	EMC32 V10.30	N/A	N/A	N/A	Mar. 23, 2024	N/A	Conduction (CO07-HY)
Pulse Limiter	SCHWARZBECK	VTSD 9561-FN	9561-FN00373	9kHz-200MHz	Oct. 20, 2023	Mar. 23, 2024	Oct. 19, 2024	Conduction (CO07-HY)
RF Cable	HUBER + SUHNER	RG 214/U	1358175	9kHz~30MHz	Mar. 14, 2024	Mar. 23, 2024	Mar. 13, 2025	Conduction (CO07-HY)
Two-Line V-Network	TESEQ	NNB 51	45051	N/A	Mar. 10, 2024	Mar. 23, 2024	Mar. 09, 2025	Conduction (CO07-HY)
Four-Line V-Network	TESEQ	NNB 52	36122	N/A	Mar. 07, 2024	Mar. 23, 2024	Mar. 06, 2025	Conduction (CO07-HY)
EMI Test Receiver	Rohde & Schwarz	ESR3	102317	9kHz~3.6GHz	Sep. 20, 2023	Mar. 23, 2024	Sep. 19, 2024	Conduction (CO07-HY)
Loop Antenna	Rohde & Schwarz	HFH2-Z2	100488	9 kHz~30 MHz	Sep. 12, 2023	Jan. 11, 2024~Mar. 27, 2024	Sep. 11, 2024	Radiation (03CH15-HY)
Bilog Antenna	TESEQ	CBL 6111D & 00800N1D01N-06	47020 & 06	30MHz~1GHz	Oct. 07, 2023	Jan. 11, 2024~Feb. 06, 2024	Oct. 06, 2024	Radiation (03CH15-HY)
Bilog Antenna	TESEQ	CBL 6111D & 00800N1D01N-06	41912 & 05	30MHz~1GHz	Feb. 04, 2024	Feb. 06, 2024~Mar. 27, 2024	Feb. 03, 2025	Radiation (03CH15-HY)
Horn Antenna	SCHWARZBECK	BBHA 9120 D	9120D-02294	1GHz~18GHz	Jun. 30, 2023	Jan. 11, 2024~Mar. 27, 2024	Jun. 29, 2024	Radiation (03CH15-HY)
SHF-EHF Horn Antenna	SCHWARZBECK	BBHA 9170	1225	18GHz~40GHz	Jul. 10, 2023	Jan. 11, 2024~Mar. 27, 2024	Jul. 09, 2024	Radiation (03CH15-HY)
Amplifier	SONOMA	310N	363440	9kHz~1GHz	Dec. 26, 2023	Jan. 11, 2024~Mar. 27, 2024	Dec. 25, 2024	Radiation (03CH15-HY)
Preamplifier	EMEC	EM01G18G	060812	1GHz~18GHz	Dec. 25, 2023	Jan. 11, 2024~Feb. 20, 2024	Dec. 24, 2024	Radiation (03CH15-HY)
Preamplifier	EMEC	EM01G18G	060837	1GHz~18GHz	Feb. 15, 2024	Feb. 20, 2024~Mar. 27, 2024	Feb. 14, 2025	Radiation (03CH15-HY)
Preamplifier	Keysight	83017A	MY53270264	1GHz~26.5GHz	Dec. 07, 2023	Jan. 11, 2024~Mar. 01, 2024	Dec. 06, 2024	Radiation (03CH15-HY)
Preamplifier	EM Electronics	EM01G18G	060802	1GHz~18GHz	Feb. 29, 2024	Mar. 01, 2024~Mar. 27, 2024	Feb. 28, 2025	Radiation (03CH15-HY)
Preamplifier	EMEC	EM18G40G	060801	18GHz~40GHz	Jun. 27, 2023	Jan. 11, 2024~Mar. 27, 2024	Jun. 26, 2024	Radiation (03CH15-HY)
EMI Test Receiver	Keysight	N9038A(MXE)	MY53290045	20MHz~8.4GHz	Oct. 06, 2023	Jan. 11, 2024~Mar. 27, 2024	Oct. 05, 2024	Radiation (03CH15-HY)
Spectrum Analyzer	Keysight	N9010B	MY60241058	10Hz~44GHz	Jul. 06, 2023	Jan. 11, 2024~Mar. 27, 2024	Jul. 05, 2024	Radiation (03CH15-HY)
Antenna Mast	ChainTek	MBS-520-1	N/A	1m~4m	N/A	Jan. 11, 2024~Mar. 27, 2024	N/A	Radiation (03CH15-HY)



Instrument	Brand Name	Model No.	Serial No.	Characteristics	Calibration Date	Test Date	Due Date	Remark
Turn Table	ChainTek	T-200-S-1	N/A	0~360 Degree	N/A	Jan. 11, 2024~ Mar. 27, 2024	N/A	Radiation (03CH15-HY)
Software	Audix	E3 6.2009-8-24(k5)	RK-000451	N/A	N/A	Jan. 11, 2024~ Mar. 27, 2024	N/A	Radiation (03CH15-HY)
RF Cable	HUBER + SUHNER	SUCOFLEX 104, 102E	MY582185/4, 519228/2,803 950/2	N/A	Jun. 13, 2023	Jan. 11, 2024~ Mar. 27, 2024	Jun. 12, 2024	Radiation (03CH15-HY)
RF Cable	HUBER + SUHNER	SUCOFLEX 102	804011/2,804 012/2	18-40G	Jan. 02, 2024	Jan. 11, 2024~ Mar. 27, 2024	Jan. 01, 2025	Radiation (03CH15-HY)
Filter	Wainwright	WLJ4-1000-15 30-6000-40ST	SN4	1.53GHz Low Pass Filter	Jun. 14, 2023	Jan. 11, 2024~ Mar. 27, 2024	Jun. 13, 2024	Radiation (03CH15-HY)
Filter	Wainwright	WHKX12-2700 -3000-18000-6 0ST	SN4	3GHz High Pass Filter	Jun. 14, 2023	Jan. 11, 2024~ Mar. 27, 2024	Jun. 13, 2024	Radiation (03CH15-HY)
Hygrometer	TECPEL	DTM-302	SN4	N/A	Jul. 26, 2023	Jan. 11, 2024~ Mar. 27, 2024	Jul. 25, 2024	Radiation (03CH15-HY)
Hygrometer	TECPEL	DTM-303A	TP201996	N/A	Nov. 07, 2023	Mar. 27, 2024~ Mar. 28, 2024	Nov. 06, 2024	Conducted (TH05-HY)
Power Meter	Agilent	E4416A	GB41292344	N/A	Jul. 12, 2023	Mar. 27, 2024~ Mar. 28, 2024	Jul. 11, 2024	Conducted (TH05-HY)
Power Meter	Agilent	E9327A	US40441548	50MHz~18GHz	Jul. 12, 2023	Mar. 27, 2024~ Mar. 28, 2024	Jul. 11, 2024	Conducted (TH05-HY)
Signal Analyzer	Rohde & Schwarz	FSV3044	101436	10HZ~44GHZ	Nov. 27, 2023	Mar. 27, 2024~ Mar. 28, 2024	Nov. 26, 2024	Conducted (TH05-HY)



5 Measurement Uncertainty

Uncertainty of Conducted Emission Measurement (150 kHz ~ 30 MHz)

Measuring Uncertainty for a Level of Confidence of 95% ($U = 2Uc(y)$)	3.44 dB
---	---------

Uncertainty of Radiated Emission Measurement (30 MHz ~ 1000 MHz)

Measuring Uncertainty for a Level of Confidence of 95% ($U = 2Uc(y)$)	6.3 dB
---	--------

Uncertainty of Radiated Emission Measurement (1000 MHz ~ 6000 MHz)

Measuring Uncertainty for a Level of Confidence of 95% ($U = 2Uc(y)$)	4.5 dB
---	--------

Uncertainty of Radiated Emission Measurement (6000 MHz ~ 18000 MHz)

Measuring Uncertainty for a Level of Confidence of 95% ($U = 2Uc(y)$)	5.5 dB
---	--------

Uncertainty of Radiated Emission Measurement (18000 MHz ~ 40000 MHz)

Measuring Uncertainty for a Level of Confidence of 95% ($U = 2Uc(y)$)	5.4 dB
---	--------

Appendix A. Test Result of Conducted Test Items

Test Engineer:	Willy Chang	Temperature:	21~25	°C
Test Date:	2024/3/27~2024/3/28	Relative Humidity:	51~54	%

TEST RESULTS DATA
6dB and 99% Occupied Bandwidth

Mod.	Data Rate	N _{TX}	CH.	Freq. (MHz)	99% Occupied BW (MHz)	6dB BW (MHz)	6dB BW Limit (MHz)	Pass/Fail
Thread	250K	1	11	2405	2.208	1.541	0.50	Pass
Thread	250K	1	18	2440	2.208	1.533	0.50	Pass
Thread	250K	1	25	2475	2.208	1.544	0.50	Pass
Thread	250K	1	26	2480	2.218	1.545	0.50	Pass

TEST RESULTS DATA
Peak Power Table

Mod.	Data Rate	N _{TX}	CH.	Freq. (MHz)	Peak Conducted Power (dBm)	Conducted Power Limit (dBm)	DG (dBi)	EIRP Power (dBm)	EIRP Power Limit (dBm)	Pass /Fail
Thread	250K	1	11	2405	18.77	30.00	-0.10	18.67	36.00	Pass
Thread	250K	1	18	2440	18.66	30.00	-0.10	18.56	36.00	Pass
Thread	250K	1	25	2475	19.36	30.00	-0.10	19.26	36.00	Pass
Thread	250K	1	26	2480	19.00	30.00	-0.10	18.90	36.00	Pass

TEST RESULTS DATA
Average Power Table
(Reporting Only)

Mod.	Data Rate	N _{TX}	CH.	Freq. (MHz)	Average Conducted Power (dBm)	Conducted Power Limit (dBm)	DG (dBi)	EIRP Power (dBm)	EIRP Power Limit (dBm)	Pass /Fail
Thread	250K	1	11	2405	18.16	30.00	-0.10	18.06	36.00	Pass
Thread	250K	1	18	2440	18.04	30.00	-0.10	17.94	36.00	Pass
Thread	250K	1	25	2475	18.75	30.00	-0.10	18.65	36.00	Pass
Thread	250K	1	26	2480	18.38	30.00	-0.10	18.28	36.00	Pass

TEST RESULTS DATA
Peak Power Density

Mod.	Data Rate	N _{TX}	CH.	Freq. (MHz)	Peak PSD (dBm /100kHz)	Peak PSD (dBm /3kHz)	DG (dBi)	Peak PSD Limit (dBm /3kHz)	Pass/Fail
Thread	250K	1	11	2405	15.28	4.32	-0.10	8.00	Pass
Thread	250K	1	18	2440	14.76	3.84	-0.10	8.00	Pass
Thread	250K	1	25	2475	15.69	4.45	-0.10	8.00	Pass
Thread	250K	1	26	2480	15.26	3.86	-0.10	8.00	Pass

Note: PSD (dBm/ 100kHz) is a reference level used for Conducted Band Edges and Conducted Spurious Emission 20dBc limit.



6dB Bandwidth

6 dB Bandwidth Plot on Channel 11

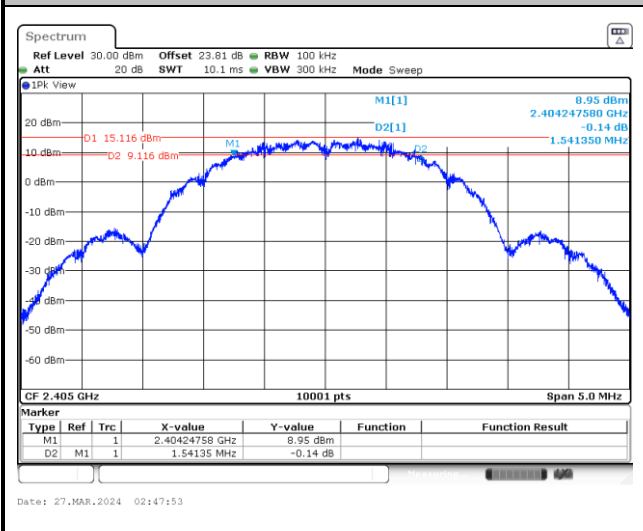

6 dB Bandwidth Plot on Channel 18

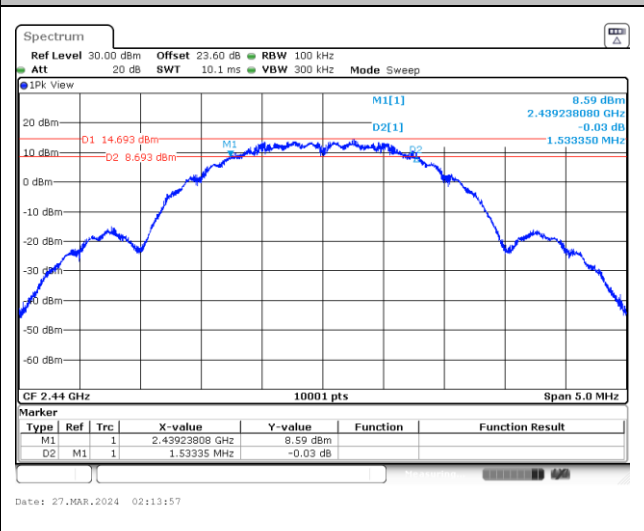

6 dB Bandwidth Plot on Channel 25

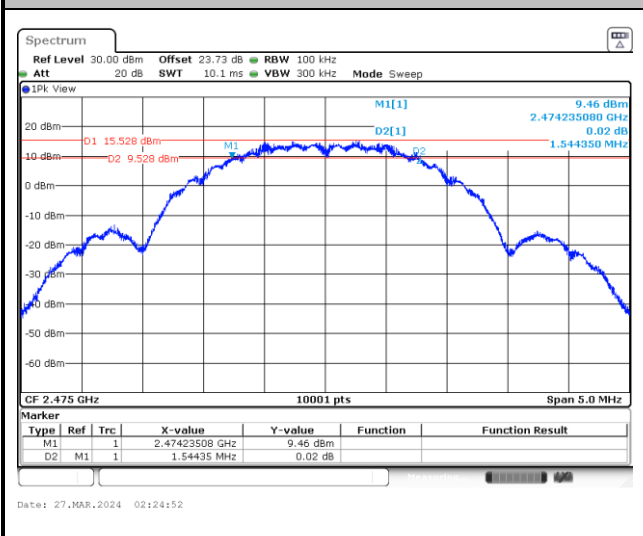

6 dB Bandwidth Plot on Channel 26

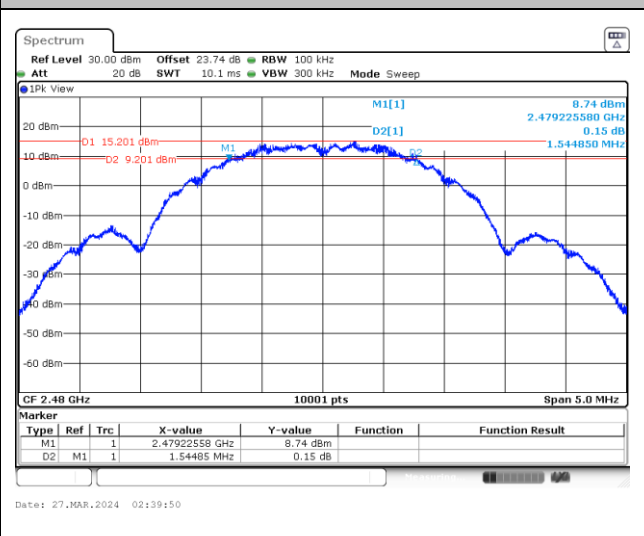



99% Occupied Bandwidth

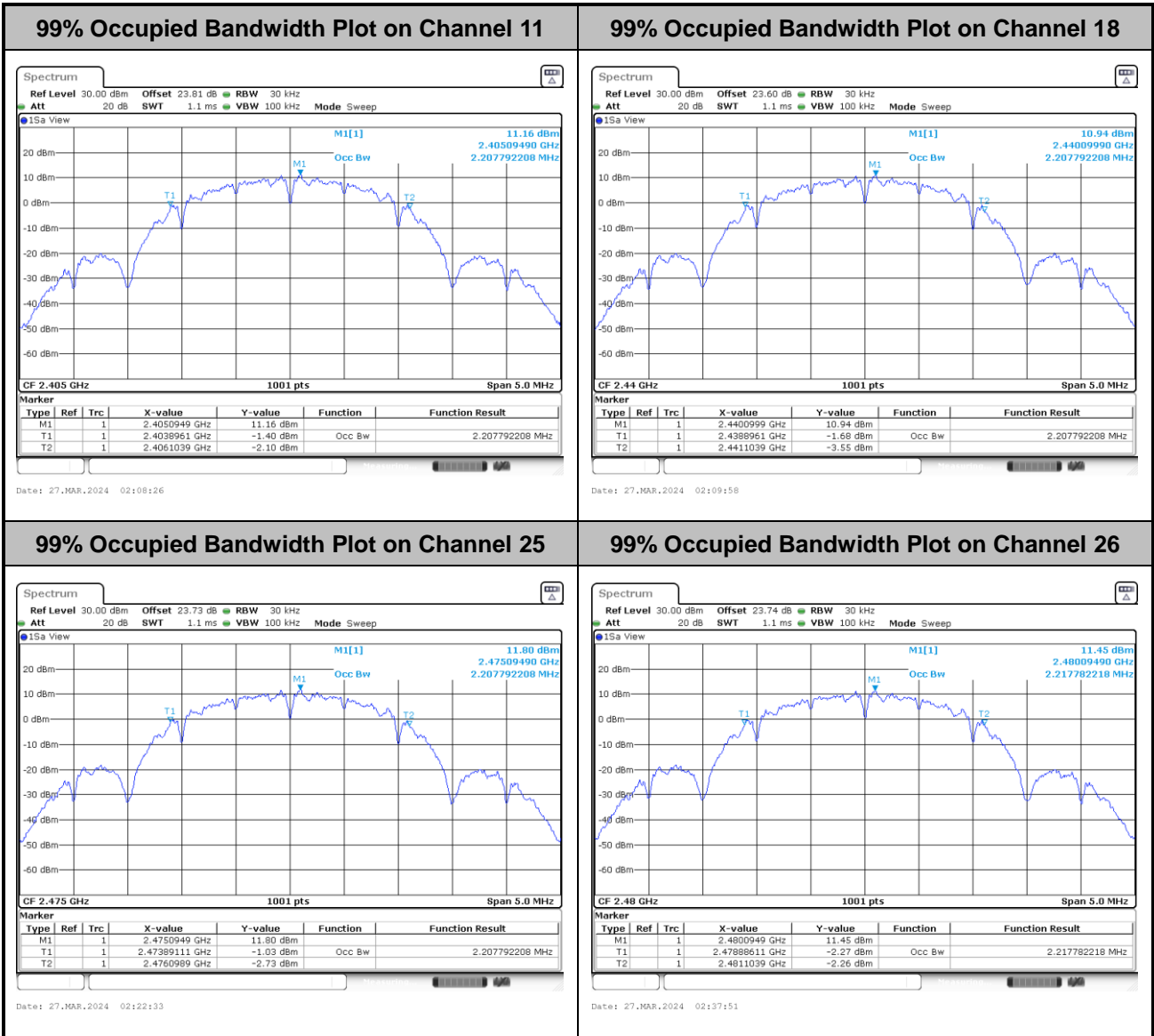



Power Spectral Density (dBm/3kHz)

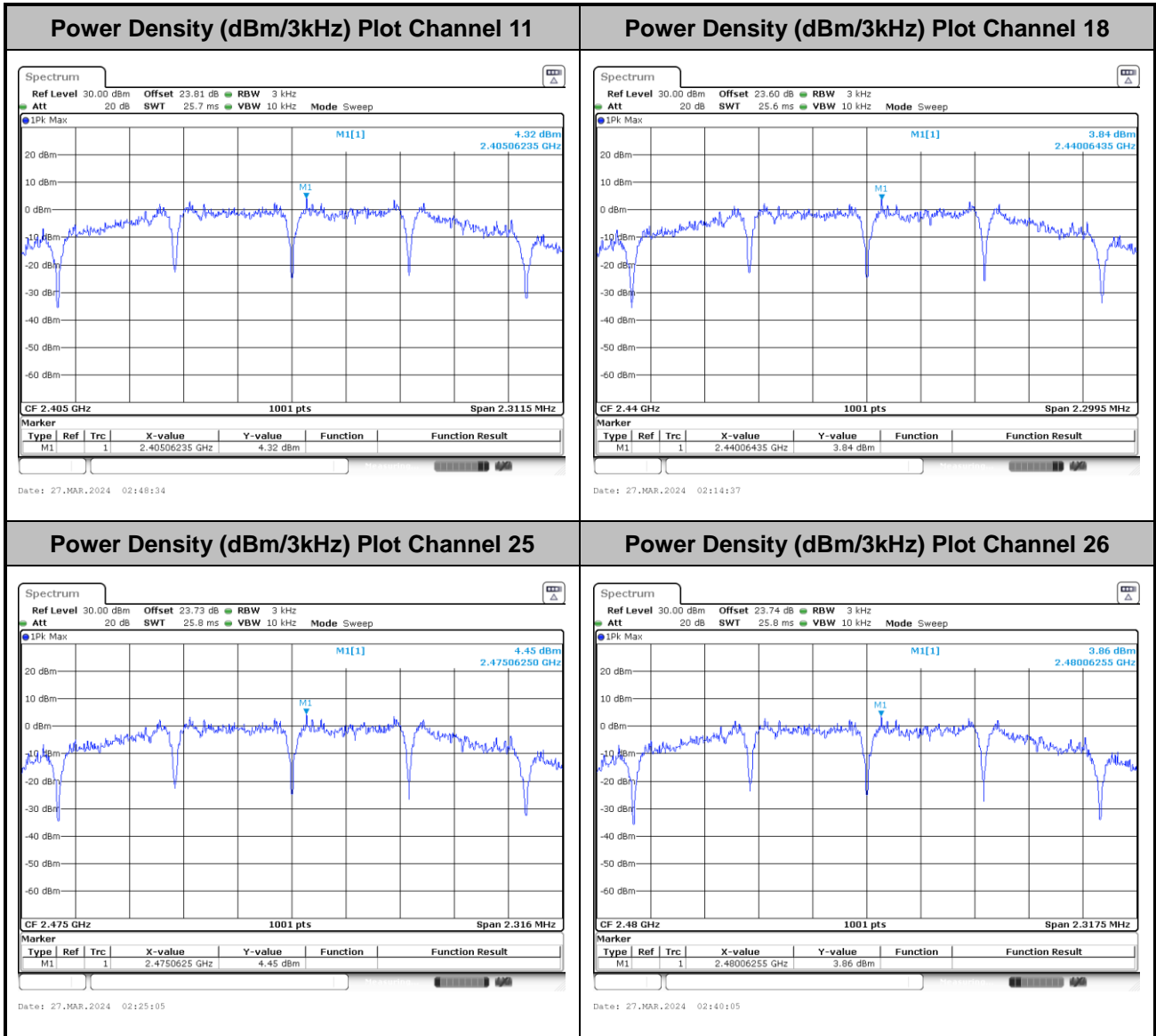



Band Edge and Conducted Spurious Emission

Channel 11

100kHz PSD reference Level Plot

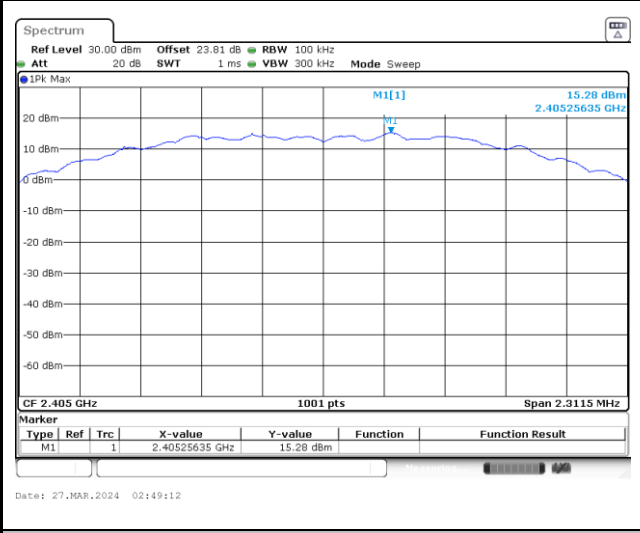

Low Channel Plot

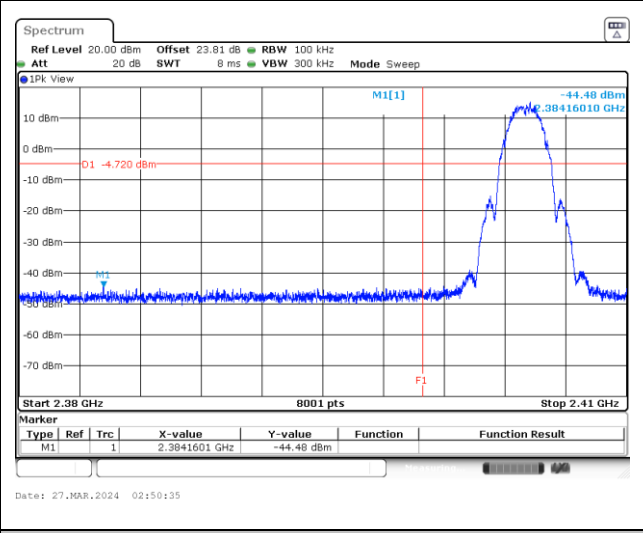

Spurious Emission 30MHz~1GHz Plot

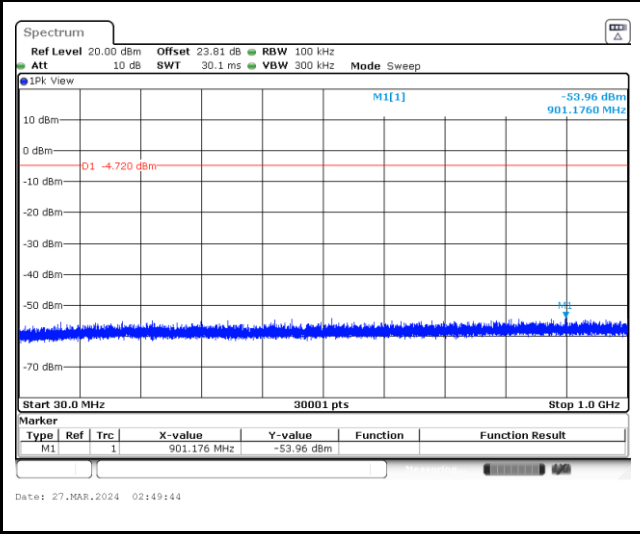

Spurious Emission 1GHz~26.5GHz Plot

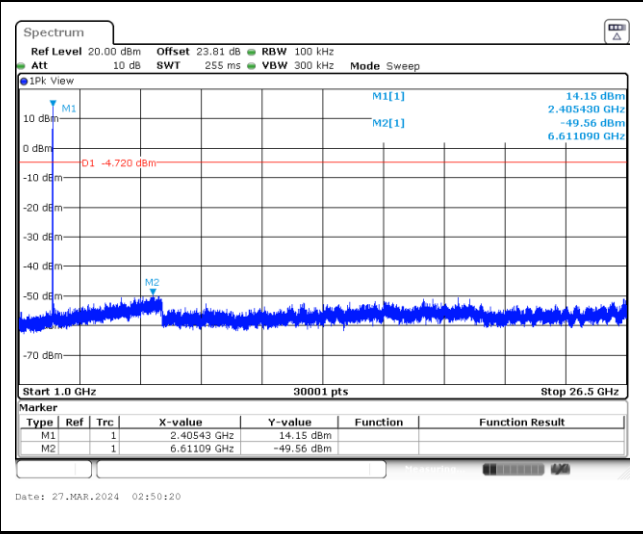



Channel 18

100kHz PSD reference Level Plot

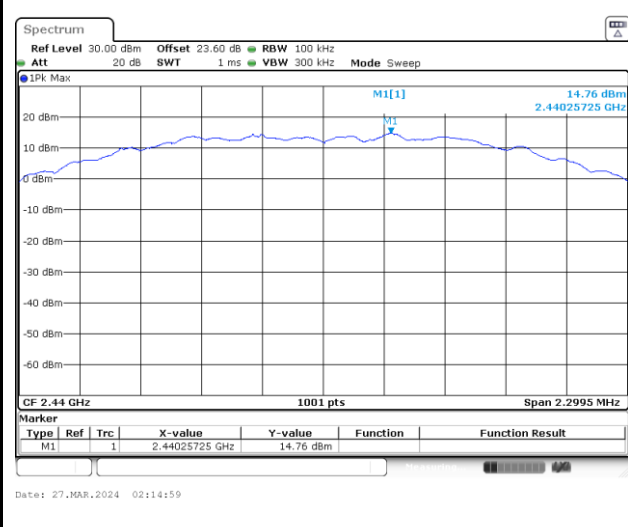

Middle Channel Plot



Spurious Emission 30MHz~1GHz Plot

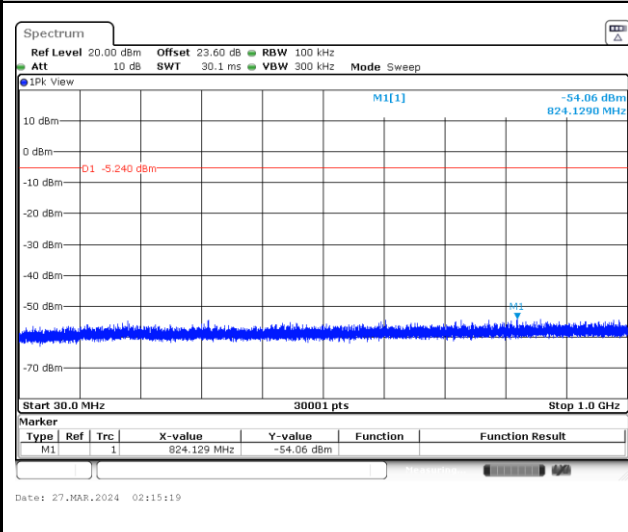

Spurious Emission 1GHz~26.5GHz Plot

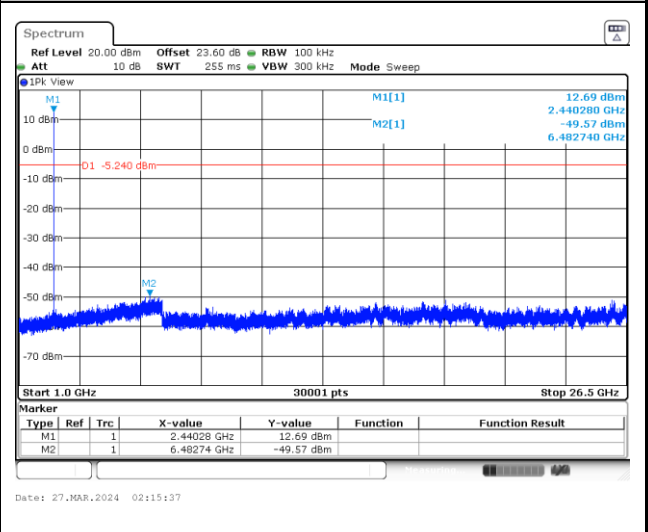



Channel 25

100kHz PSD reference Level Plot

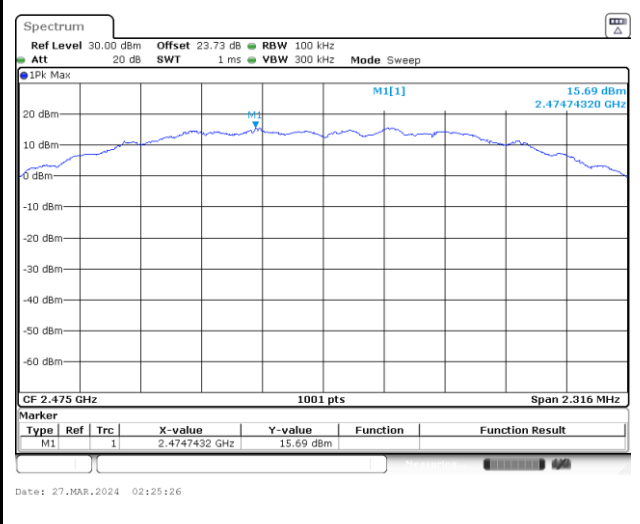

High Channel Plot



Spurious Emission 30MHz~1GHz Plot

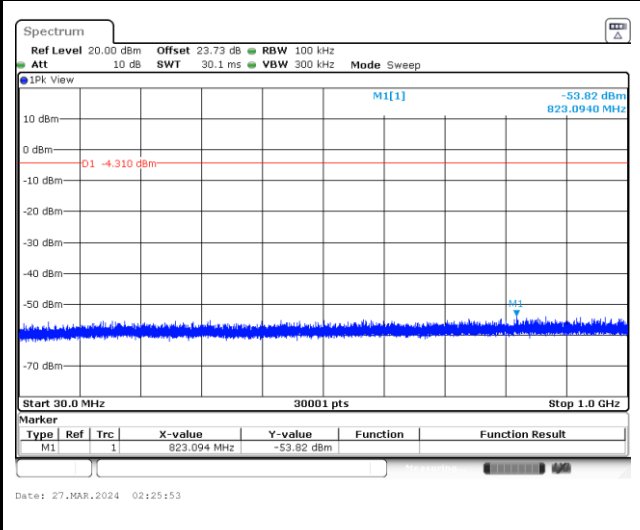

Spurious Emission 1GHz~26.5GHz Plot

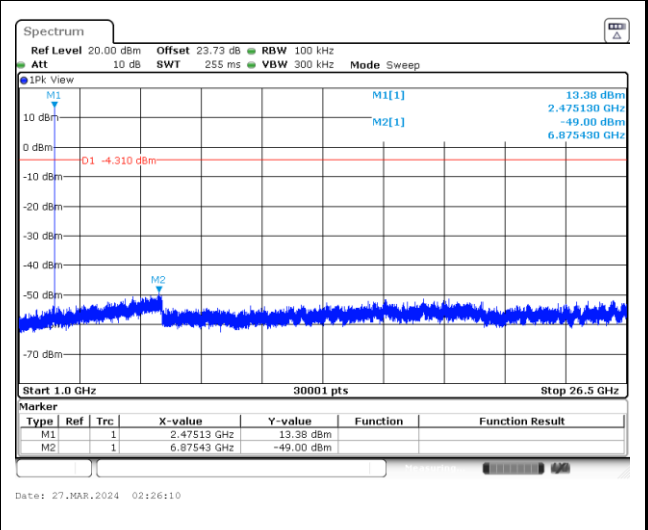



Channel 26

100kHz PSD reference Level Plot

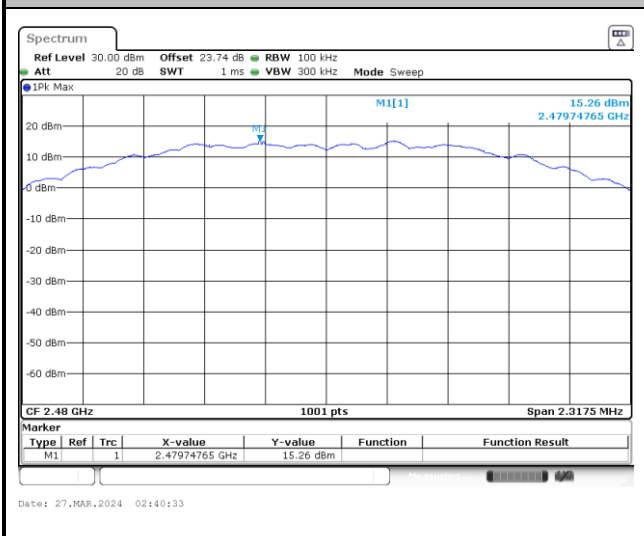

High Channel Plot

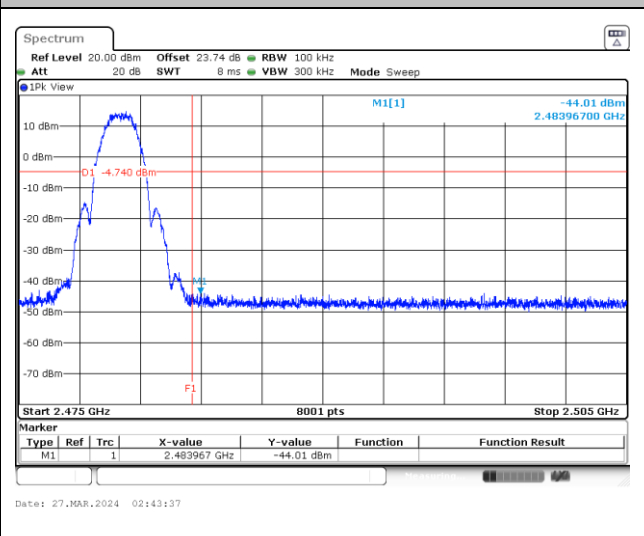

Spurious Emission 30MHz~1GHz Plot

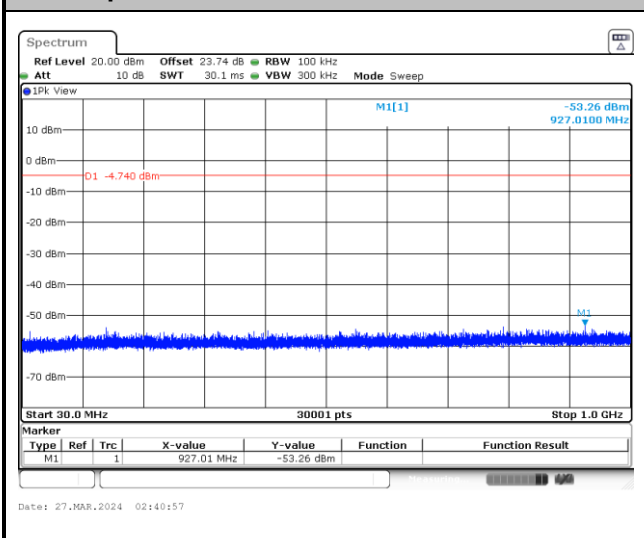

Spurious Emission 1GHz~26.5GHz Plot

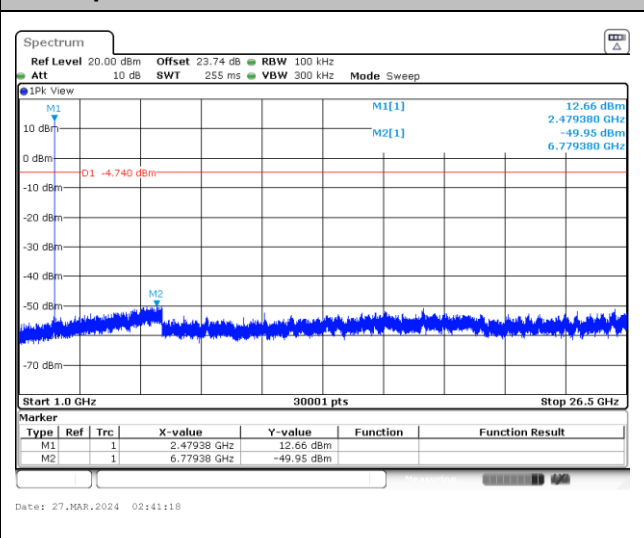



Appendix B. AC Conducted Emission Test Results

Test Engineer :	Louis Chung	Temperature :	19.2~23.3°C
		Relative Humidity :	49.5~53.6%

EUT Information

Report NO : 3N2325

Test Voltage : 120Vac/60Hz
Phase : Line

Full Spectrum

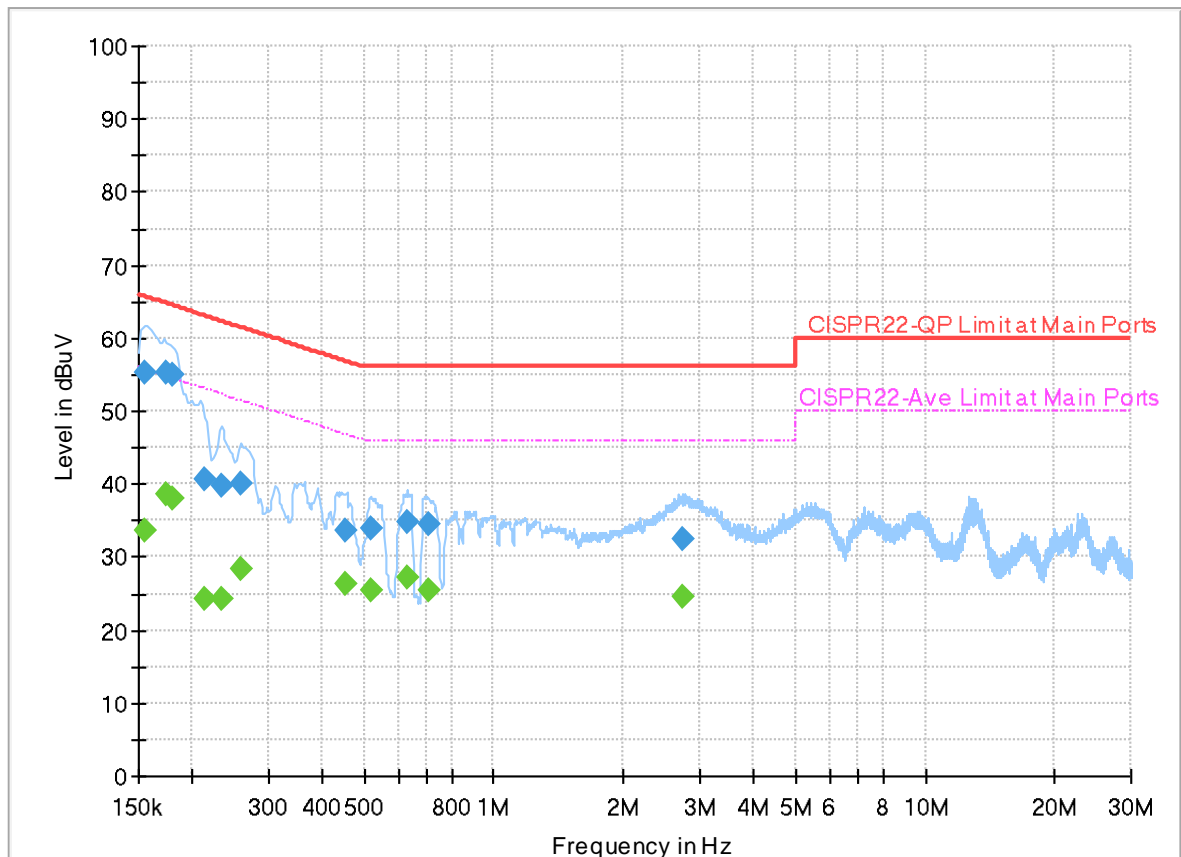

Final_Result

Frequency (MHz)	QuasiPeak (dBuV)	CAverage (dBuV)	Limit (dBuV)	Margin (dB)	Line	Filter	Corr. (dB)
0.155760	---	33.53	55.69	22.16	L1	OFF	19.9
0.155760	55.14	---	65.69	10.55	L1	OFF	19.9
0.174750	---	38.69	54.73	16.04	L1	OFF	19.9
0.174750	55.14	---	64.73	9.59	L1	OFF	19.9
0.179250	---	38.06	54.52	16.46	L1	OFF	19.9
0.179250	55.04	---	64.52	9.48	L1	OFF	19.9
0.213000	---	24.12	53.09	28.97	L1	OFF	19.9
0.213000	40.51	---	63.09	22.58	L1	OFF	19.9
0.233160	---	24.15	52.34	28.19	L1	OFF	19.9
0.233160	39.65	---	62.34	22.69	L1	OFF	19.9
0.260250	---	28.39	51.42	23.03	L1	OFF	19.9
0.260250	40.10	---	61.42	21.32	L1	OFF	19.9
0.455460	---	26.35	46.78	20.43	L1	OFF	19.9
0.455460	33.62	---	56.78	23.16	L1	OFF	19.9
0.520170	---	25.33	46.00	20.67	L1	OFF	19.9
0.520170	34.00	---	56.00	22.00	L1	OFF	19.9
0.629250	---	27.12	46.00	18.88	L1	OFF	19.9
0.629250	34.77	---	56.00	21.23	L1	OFF	19.9
0.705750	---	25.44	46.00	20.56	L1	OFF	19.9

0.705750	34.58	---	56.00	21.42	L1	OFF	19.9
2.737500	---	24.71	46.00	21.29	L1	OFF	20.0
2.737500	32.35	---	56.00	23.65	L1	OFF	20.0

EUT Information

Report NO : 3N2325

Test Voltage : 120Vac/60Hz
Phase : Neutral

Full Spectrum

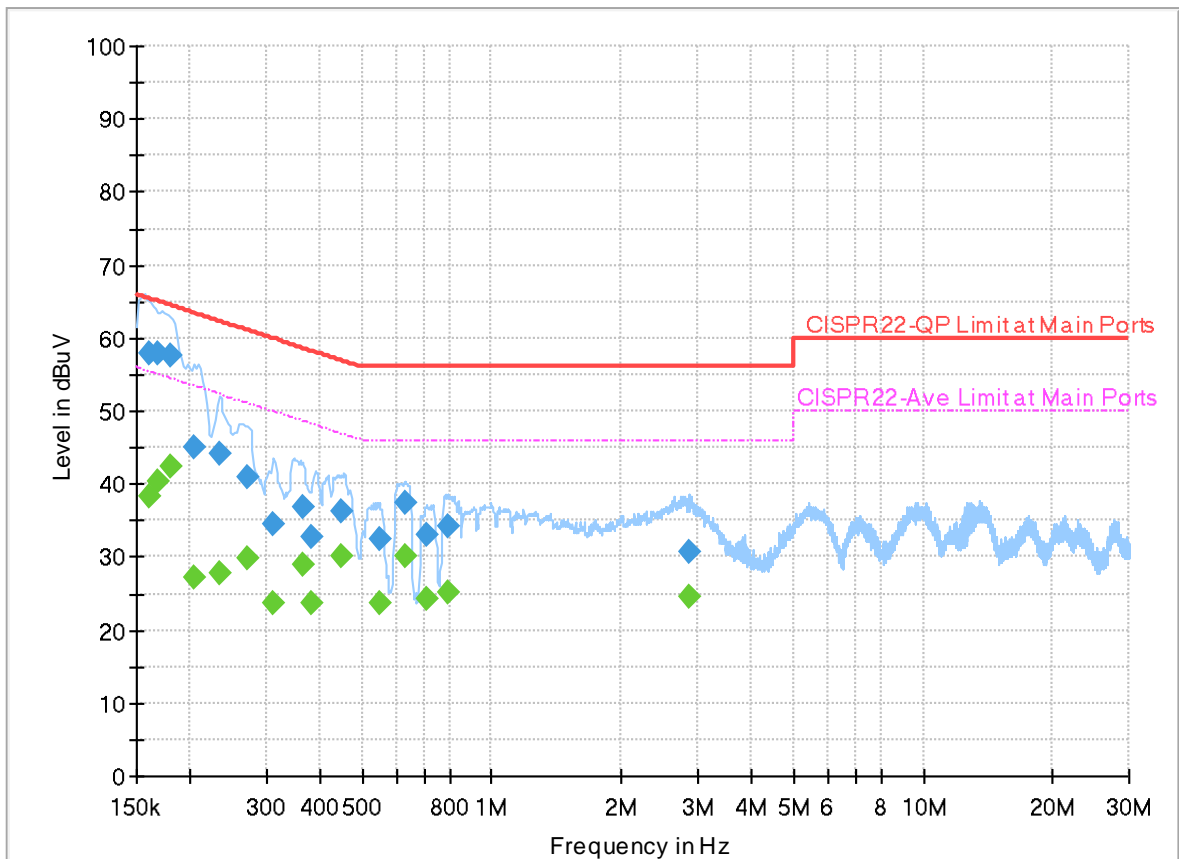

Final_Result

Frequency (MHz)	QuasiPeak (dBuV)	CAverage (dBuV)	Limit (dBuV)	Margin (dB)	Line	Filter	Corr. (dB)
0.161250	---	38.41	55.40	16.99	N	OFF	19.9
0.161250	57.98	---	65.40	7.42	N	OFF	19.9
0.168000	---	40.46	55.06	14.60	N	OFF	19.9
0.168000	57.96	---	65.06	7.10	N	OFF	19.9
0.179880	---	42.44	54.49	12.05	N	OFF	19.9
0.179880	57.70	---	64.49	6.79	N	OFF	19.9
0.204270	---	27.24	53.44	26.20	N	OFF	19.9
0.204270	44.89	---	63.44	18.55	N	OFF	19.9
0.235230	---	27.69	52.26	24.57	N	OFF	19.9
0.235230	44.05	---	62.26	18.21	N	OFF	19.9
0.271590	---	29.76	51.07	21.31	N	OFF	19.9
0.271590	40.93	---	61.07	20.14	N	OFF	19.9
0.309750	---	23.71	49.98	26.27	N	OFF	19.9
0.309750	34.58	---	59.98	25.40	N	OFF	19.9
0.363300	---	29.07	48.65	19.58	N	OFF	19.9
0.363300	36.75	---	58.65	21.90	N	OFF	19.9
0.382920	---	23.74	48.22	24.48	N	OFF	19.9
0.382920	32.74	---	58.22	25.48	N	OFF	19.9
0.449250	---	30.22	46.89	16.67	N	OFF	19.9

0.449250	36.35	---	56.89	20.54	N	OFF	19.9
0.550680	---	23.79	46.00	22.21	N	OFF	19.9
0.550680	32.51	---	56.00	23.49	N	OFF	19.9
0.629430	---	30.13	46.00	15.87	N	OFF	19.9
0.629430	37.45	---	56.00	18.55	N	OFF	19.9
0.708450	---	24.30	46.00	21.70	N	OFF	19.9
0.708450	32.98	---	56.00	23.02	N	OFF	19.9
0.787470	---	25.07	46.00	20.93	N	OFF	19.9
0.787470	34.35	---	56.00	21.65	N	OFF	19.9
2.869620	---	24.52	46.00	21.48	N	OFF	20.0
2.869620	30.66	---	56.00	25.34	N	OFF	20.0



Appendix C. Radiated Spurious Emission

Test Engineer :	Daniel Lee, Quentin Liu, and Bigshow Wang	Temperature :	22.1~22.6°C
		Relative Humidity :	55~57%

2.4GHz 2400~2483.5MHz

THREAD (Band Edge @ 3m)

THREAD	Note	Frequency (MHz)	Level (dBμV/m)	Margin (dB)	Limit Line (dBμV/m)	Read Level (dBμV)	Antenna Factor (dB/m)	Path Loss (dB)	Preamp Factor (dB)	Ant Pos (cm)	Table Pos (deg)	Peak Avg. (P/A)	Pol. (H/V)	
THREAD CH 11 2405MHz		2371.635	50	-24	74	43.65	27.34	15.5	36.49	100	217	P	H	
		2387.07	39.36	-14.64	54	32.95	27.37	15.52	36.48	100	217	A	H	
	*	2405	106.87	-	-	100.38	27.42	15.55	36.48	100	217	P	H	
	*	2405	106.42	-	-	99.93	27.42	15.55	36.48	100	217	A	H	
													H	
			2386.86	49.3	-24.7	74	42.89	27.37	15.52	36.48	377	310	P	V
			2389.065	39.45	-14.55	54	33.02	27.38	15.53	36.48	377	310	A	V
	*		2405	108.93	-	-	102.44	27.42	15.55	36.48	377	310	P	V
	*		2405	105.44	-	-	98.95	27.42	15.55	36.48	377	310	A	V
														V
THREAD CH 18 2440MHz		2378.04	50.4	-23.6	74	44.02	27.36	15.51	36.49	122	223	P	H	
		2389.866	39.33	-14.67	54	32.9	27.38	15.53	36.48	122	223	A	H	
	*	2440	106.6	-	-	99.92	27.56	15.59	36.47	122	223	P	H	
	*	2440	104.47	-	-	97.79	27.56	15.59	36.47	122	223	A	H	
			2491.54	50.31	-23.69	74	43.35	27.77	15.65	36.46	122	223	P	H
			2487.13	40.06	-13.94	54	33.13	27.75	15.64	36.46	122	223	A	H
			2352.282	50.1	-23.9	74	43.81	27.3	15.48	36.49	323	303	P	V
			2388.894	39.42	-14.58	54	32.99	27.38	15.53	36.48	323	303	A	V
	*		2440	108.72	-	-	102.04	27.56	15.59	36.47	323	303	P	V
	*		2440	106.67	-	-	99.99	27.56	15.59	36.47	323	303	A	V
			2493.25	50.37	-23.63	74	43.41	27.77	15.65	36.46	323	303	P	V
			2487.22	40.12	-13.88	54	33.19	27.75	15.64	36.46	323	303	A	V



THREAD CH 25 2475MHz	*	2475	110.2	-	-	103.34	27.7	15.63	36.47	100	211	P	H
	*	2475	108.53	-	-	101.67	27.7	15.63	36.47	100	211	A	H
		2497.15	51.43	-22.57	74	44.45	27.79	15.65	36.46	100	211	P	H
		2483.77	41.05	-12.95	54	34.13	27.74	15.64	36.46	100	211	A	H
													H
													H
	*	2475	109.53	-	-	102.67	27.7	15.63	36.47	398	309	P	V
	*	2475	108.32	-	-	101.46	27.7	15.63	36.47	398	309	A	V
		2487.43	52.62	-21.38	74	45.69	27.75	15.64	36.46	398	309	P	V
		2483.62	40.77	-13.23	54	33.86	27.73	15.64	36.46	398	309	A	V
													V
													V
THREAD CH 26 2480MHz	*	2480	109.8	-	-	102.91	27.72	15.63	36.46	100	218	P	H
	*	2480	109.61	-	-	102.72	27.72	15.63	36.46	100	218	A	H
		2483.5	53.42	-20.58	74	46.51	27.73	15.64	36.46	100	218	P	H
		2483.5	46.11	-7.89	54	39.2	27.73	15.64	36.46	100	218	A	H
													H
													H
	*	2480	108.64	-	-	101.75	27.72	15.63	36.46	400	305	P	V
	*	2480	108.41	-	-	101.52	27.72	15.63	36.46	400	305	A	V
		2483.5	53.5	-20.5	74	46.59	27.73	15.64	36.46	400	305	P	V
		2483.5	46.02	-7.98	54	39.11	27.73	15.64	36.46	400	305	A	V
													V
													V
Remark	1. No other spurious found. 2. All results are PASS against Peak and Average limit line.												



**2.4GHz 2400~2483.5MHz
THREAD (Harmonic @ 3m)**

THREAD	Note	Frequency (MHz)	Level (dBµV/m)	Margin (dB)	Limit Line (dBµV/m)	Read Level (dBµV)	Antenna Factor (dB/m)	Path Loss (dB)	Preamp Factor (dB)	Ant Pos (cm)	Table Pos (deg)	Peak Avg. (P/A)	Pol. (H/V)
THREAD CH 11 2405MHz		4810	37.53	-36.47	74	56.04	32.16	8.5	59.17	-	-	P	H
													H
													H
													H
													H
													H
													H
													H
													H
													H
													H
													H
													H
													H
													H
													H
													H
													H
													H
			4810	37.41	-36.59	74	55.92	32.16	8.5	59.17	-	-	P
													V
													V
													V
													V
													V
													V
													V
													V
													V
													V
													V
													V
													V
													V



THREAD	Note	Frequency (MHz)	Level (dBµV/m)	Margin (dB)	Limit Line (dBµV/m)	Read Level (dBµV)	Antenna Factor (dB/m)	Path Loss (dB)	Preamp Factor (dB)	Ant Pos (cm)	Table Pos (deg)	Peak Avg. (P/A)	Pol. (H/V)
THREAD CH 18 2440MHz		4880	36.69	-37.31	74	54.74	32.58	8.56	59.19	-	-	P	H
		7320	42.62	-31.38	74	55.44	36.68	10.34	59.84	-	-	P	H
													H
													H
													H
													H
													H
													H
													H
													H
													H
													H
													H
													H
													H
													H
													H
													H
													H
			4880	37.32	-36.68	74	55.37	32.58	8.56	59.19	-	-	P
		7320	43.21	-30.79	74	56.03	36.68	10.34	59.84	-	-	P	V
													V
													V
													V
													V
													V
													V
													V
													V
													V
													V
													V
													V
													V
													V



THREAD	Note	Frequency (MHz)	Level (dBµV/m)	Margin (dB)	Limit Line (dBµV/m)	Read Level (dBµV)	Antenna Factor (dB/m)	Path Loss (dB)	Preamp Factor (dB)	Ant Pos (cm)	Table Pos (deg)	Peak Avg. (P/A)	Pol. (H/V)
THREAD CH 25 2475MHz		4950	37.76	-36.24	74	55.39	32.95	8.63	59.21	-	-	P	H
		7425	42.52	-31.48	74	55.89	36.15	10.44	59.96	-	-	P	H
													H
													H
													H
													H
													H
													H
													H
													H
													H
													H
													H
													H
													H
													H
													H
													H
													H
			4950	38.13	-35.87	74	55.76	32.95	8.63	59.21	-	-	P
		7425	43.56	-30.44	74	56.93	36.15	10.44	59.96	-	-	P	V
													V
													V
													V
													V
													V
													V
													V
													V
													V
													V
													V
													V
													V
Remark	<ol style="list-style-type: none"> No other spurious found. All results are PASS against Peak and Average limit line. The emission position marked as "-" means no suspected emission found with sufficient margin against limit line or noise floor only. 												



THREAD	Note	Frequency (MHz)	Level (dBµV/m)	Margin (dB)	Limit Line (dBµV/m)	Read Level (dBµV)	Antenna Factor (dB/m)	Path Loss (dB)	Preamp Factor (dB)	Ant Pos (cm)	Table Pos (deg)	Peak Avg. (P/A)	Pol. (H/V)
THREAD CH 26 2480MHz		4960	37.52	-36.48	74	55.11	33	8.63	59.22	-	-	P	H
		7440	42.54	-31.46	74	55.93	36.12	10.47	59.98	-	-	P	H
													H
													H
													H
													H
													H
													H
													H
													H
													H
													H
													H
													H
													H
													H
													H
													H
													H
			4960	37.82	-36.18	74	55.41	33	8.63	59.22	-	-	P
		7440	42.82	-31.18	74	56.21	36.12	10.47	59.98	-	-	P	V
													V
													V
													V
													V
													V
													V
													V
													V
													V
													V
													V
													V
													V
Remark	<ol style="list-style-type: none"> No other spurious found. All results are PASS against Peak and Average limit line. The emission position marked as "-" means no suspected emission found with sufficient margin against limit line or noise floor only. 												



Emission above 18GHz

2.4GHz THREAD (SHF)

BT	Note	Frequency	Level	Margin	Limit	Read	Antenna	Path	Preamp	Ant	Table	Peak	Pol.
		(MHz)	(dBμV/m)	(dB)	(dBμV/m)	(dBμV)	(dB/m)	(dB)	(dB)	(cm)	(deg)	(P/A)	(H/V)
2.4GHz THREAD SHF		24723.5	40.44	-33.56	74	57.05	39.21	-2.41	53.41	-	-	P	H
													H
													H
													H
													H
													H
													H
													H
													H
													H
													H
													H
													H
													H
													H
													H
													H
													H
													H
			24638.5	40.86	-33.14	74	57.53	39.18	-2.41	53.44	-	-	P
													V
													V
													V
													V
													V
													V
													V
													V
													V
													V
													V
													V
													V
													V

Remark

- No other spurious found.
- All results are PASS against limit line.
- The emission position marked as "-" means no suspected emission found with sufficient margin against limit line or noise floor only.



Emission below 1GHz

2.4GHz THREAD (LF)

THREAD	Note	Frequency	Level	Margin	Limit	Read	Antenna	Path	Preamp	Ant	Table	Peak	Pol.	
		(MHz)	(dBμV/m)	(dB)	(dBμV/m)	(dBμV)	(dB/m)	(dB)	(dB)	(cm)	(deg)	(P/A)	(H/V)	
2.4GHz THREAD LF		30.18	23.54	-16.46	40	30.56	24.58	0.72	32.32	-	-	P	H	
		85.8	22.54	-17.46	40	39.47	14.2	1.23	32.36	-	-	P	H	
		178.14	23.22	-20.28	43.5	38.7	15.08	1.81	32.37	-	-	P	H	
		718.4	33.28	-12.72	46	36.15	26.21	3.2	32.28	-	-	P	H	
		897.6	33.74	-12.26	46	33.42	28.2	3.6	31.48	-	-	P	H	
		954.4	33	-13	46	30.39	29.83	3.76	30.98	-	-	P	H	
														H
														H
														H
														H
														H
														H
			34.5	25.37	-14.63	40	34.38	22.65	0.75	32.41	-	-	P	V
			51.78	33.41	-6.59	40	51.1	13.83	0.94	32.46	-	-	P	V
			111.36	23.23	-20.27	43.5	37.45	16.88	1.34	32.44	-	-	P	V
			709.6	37.48	-8.52	46	40.22	26.38	3.18	32.3	-	-	P	V
			854.4	31.16	-14.84	46	31.03	28.43	3.48	31.78	-	-	P	V
			957.6	32.5	-13.5	46	29.85	29.83	3.77	30.95	-	-	P	V
														V
														V
													V	
													V	
													V	
													V	

Remark

- No other spurious found.
- All results are PASS against limit line.
- The emission position marked as "-" means no suspected emission found and emission level has at least 6dB margin against limit or emission is noise floor only.



Note symbol

*	Fundamental Frequency which can be ignored. However, the level of any unwanted emissions shall not exceed the level of the fundamental frequency.
!	Test result is over limit line.
P/A	Peak or Average
H/V	Horizontal or Vertical



A calculation example for radiated spurious emission is shown as below:

THREAD	Note	Frequency	Level	Over	Limit	Read	Antenna	Path	Preamp	Ant	Table	Peak	Pol.
		(MHz)	(dBμV/m)	(dB)	(dBμV/m)	(dBμV)	(dB/m)	(dB)	(dB)	(cm)	(deg)	(P/A)	(H/V)
THREAD CH 02 2404MHz		2390	55.45	-18.55	74	54.51	32.22	4.58	35.86	103	308	P	H
		2390	43.54	-10.46	54	42.6	32.22	4.58	35.86	103	308	A	H

1. Path Loss(dB) = CaThread loss(dB) + Filter loss(dB) + Attenuator loss(dB)
2. Level(dBμV/m) =
Antenna Factor(dB/m) + Path Loss(dB) + Read Level(dBμV) - Preamp Factor(dB)
3. Over Limit(dB) = Level(dBμV/m) – Limit Line(dBμV/m)

For Peak Limit @ 2390MHz:

1. Level(dBμV/m)
= Antenna Factor(dB/m) + Path Loss(dB) + Read Level(dBμV) - Preamp Factor(dB)
= 32.22(dB/m) + 4.58(dB) + 54.51(dBμV) – 35.86 (dB)
= 55.45 (dBμV/m)
2. Over Limit(dB)
= Level(dBμV/m) – Limit Line(dBμV/m)
= 55.45(dBμV/m) – 74(dBμV/m)
= -18.55(dB)

For Average Limit @ 2390MHz:

1. Level(dBμV/m)
= Antenna Factor(dB/m) + Path Loss(dB) + Read Level(dBμV) - Preamp Factor(dB)
= 32.22(dB/m) + 4.58(dB) + 42.6(dBμV) – 35.86 (dB)
= 43.54 (dBμV/m)
2. Over Limit(dB)
= Level(dBμV/m) – Limit Line(dBμV/m)
= 43.54(dBμV/m) – 54(dBμV/m)
= -10.46(dB)

Both peak and average measured complies with the limit line, so test result is “PASS”.



Appendix D. Radiated Spurious Emission Plots

Test Engineer :	Daniel Lee, Quentin Liu, and Bigshow Wang	Temperature :	22.1~22.6°C
		Relative Humidity :	55~57%

Note symbol

-L	Low channel location
-R	High channel location

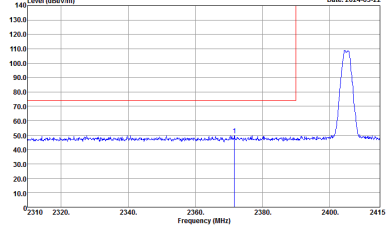
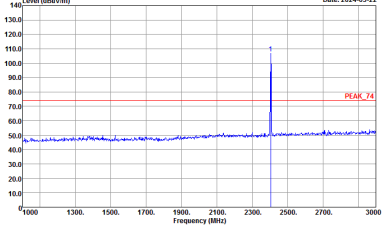
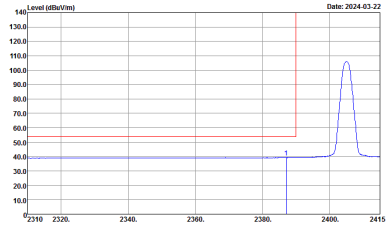
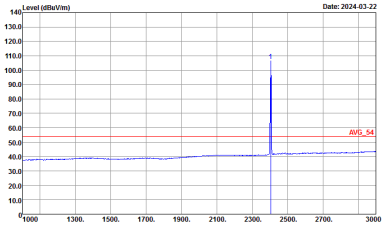

2.4GHz 2400~2483.5MHz
THREAD (Band Edge @ 3m)

THRE	2.4GHz 2400~2483.5MHz Band Edge @ 3m	
AD		
ANT	THREAD CH11 2405MHz	
3	Horizontal	Fundamental
Peak	 <p>Site : 03CH15-HY Condition : PEAK_BE_74 3m 91200_02294_230630 HORIZONTAL : RBW:1000.000KHz VBW:3000.000KHz SWT:Auto</p>	 <p>Site : 03CH15-HY Condition : PEAK_74 3m 91200_02294_230630 HORIZONTAL : RBW:1000.000KHz VBW:3000.000KHz SWT:Auto</p>
Avg.	 <p>Site : 03CH15-HY Condition : AVG_BE_54 3m 91200_02294_230630 HORIZONTAL : RBW:1000.000KHz VBW:0.300KHz SWT:Auto</p>	 <p>Site : 03CH15-HY Condition : AVG_54 3m 91200_02294_230630 HORIZONTAL : RBW:1000.000KHz VBW:0.300KHz SWT:Auto</p>

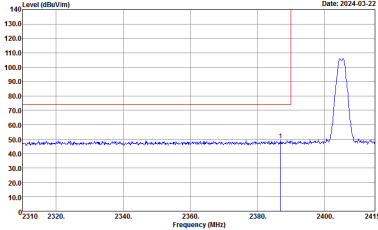
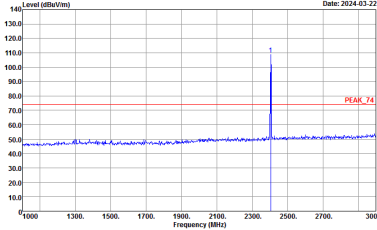
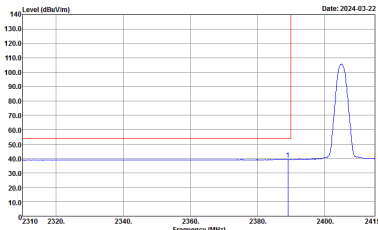
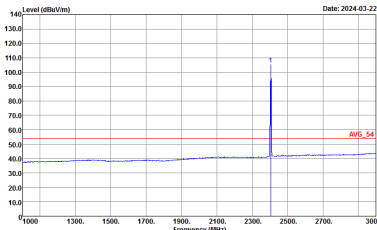

THRE AD	2.4GHz 2400~2483.5MHz Band Edge @ 3m	
ANT	THREAD CH11 2405MHz	
3	Vertical	Fundamental
Peak	 <p>Site : 03CH15-HY Condition : PEAK_BE_74 3m 91200_02294_230630 VERTICAL : RBW:1000.000KHz VBW:3000.000KHz SWT:Auto</p>	 <p>Site : 03CH15-HY Condition : PEAK_74 3m 91200_02294_230630 VERTICAL : RBW:1000.000KHz VBW:3000.000KHz SWT:Auto</p>
Avg.	 <p>Site : 03CH15-HY Condition : AVG_BE_54 3m 91200_02294_230630 VERTICAL : RBW:1000.000KHz VBW:0.300KHz SWT:Auto</p>	 <p>Site : 03CH15-HY Condition : AVG_54 3m 91200_02294_230630 VERTICAL : RBW:1000.000KHz VBW:0.300KHz SWT:Auto</p>

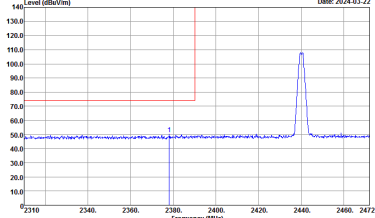
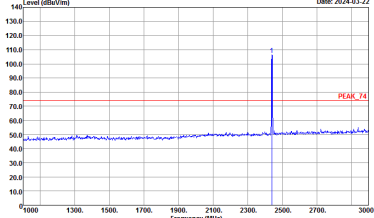
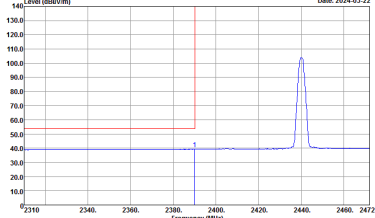
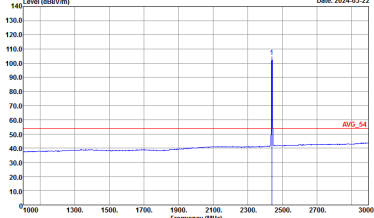

THRE AD	2.4GHz 2400~2483.5MHz Band Edge @ 3m	
ANT	THREAD CH18 2440MHz - L	
3	Horizontal	Fundamental
Peak	 <p>Date: 2024-03-22</p> <p>Site : 03CH15-HY Condition : PEAK_BE_74 3m 91200_02294_230630 HORIZONTAL : RBW:1000.000kHz VBW:3000.000kHz SWT:Auto</p>	 <p>Date: 2024-03-22</p> <p>Site : 03CH15-HY Condition : PEAK_74 3m 91200_02294_230630 HORIZONTAL : RBW:1000.000kHz VBW:3000.000kHz SWT:Auto</p>
Avg.	 <p>Date: 2024-03-22</p> <p>Site : 03CH15-HY Condition : AVG_BE_54 3m 91200_02294_230630 HORIZONTAL : RBW:1000.000kHz VBW:3000.000kHz SWT:Auto</p>	 <p>Date: 2024-03-22</p> <p>Site : 03CH15-HY Condition : AVG_54 3m 91200_02294_230630 HORIZONTAL : RBW:1000.000kHz VBW:3000.000kHz SWT:Auto</p>



THRE AD	2.4GHz 2400~2483.5MHz Band Edge @ 3m	
ANT	THREAD CH38 2440MHz - R	
3	Horizontal	Fundamental
Peak	<p>Site : 03CH15-HY Condition : PEAK_BE_74 3m 91200_02294_230630 HORIZONTAL : RBW:1000.000kHz VBW:3000.000kHz SWF:Auto</p>	Left blank
Avg.	<p>Site : 03CH15-HY Condition : AVG_BE_54 3m 91200_02294_230630 HORIZONTAL : RBW:1000.000kHz VBW:3000.000kHz SWF:Auto</p>	Left blank

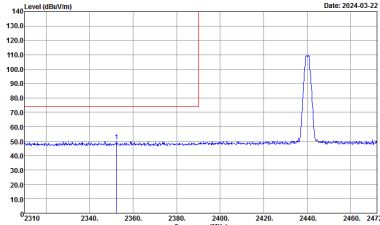
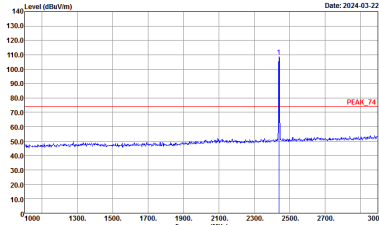
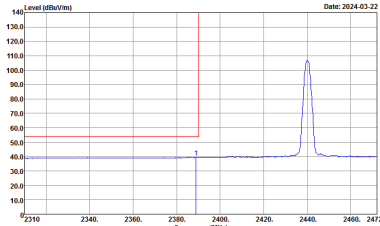
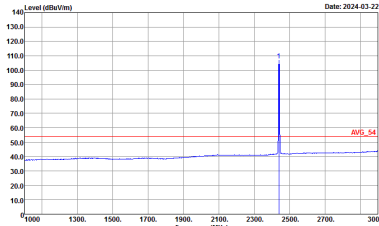

THRE AD	2.4GHz 2400~2483.5MHz Band Edge @ 3m	
ANT	THREAD CH18 2440MHz - L	
3	Vertical	Fundamental
Peak	 <p>Site : 03CH15-HY Condition : PEAK_BE_74 3m 91200_02294_230630 VERTICAL : RBW:1000.000KHz VBW:3000.000KHz SWT:Auto</p>	 <p>Site : 03CH15-HY Condition : PEAK_74 3m 91200_02294_230630 VERTICAL : RBW:1000.000KHz VBW:3000.000KHz SWT:Auto</p>
Avg.	 <p>Site : 03CH15-HY Condition : AVG_BE_54 3m 91200_02294_230630 VERTICAL : RBW:1000.000KHz VBW:0.300KHz SWT:Auto</p>	 <p>Site : 03CH15-HY Condition : AVG_54 3m 91200_02294_230630 VERTICAL : RBW:1000.000KHz VBW:0.300KHz SWT:Auto</p>



THRE AD	2.4GHz 2400~2483.5MHz Band Edge @ 3m	
ANT	THREAD CH38 2440MHz - R	
3	Vertical	Fundamental
Peak		Left blank
Avg.		Left blank



THRE AD	2.4GHz 2400~2483.5MHz Band Edge @ 3m	
ANT	THREAD CH25 2475MHz	
3	Horizontal	Fundamental
Peak	<p>Site : 03CH15-HY Condition : PEAK_BE_74 3m 91200_02294_230630 HORIZONTAL : RBW:1000.000KHz VBW:3000.000KHz SWT:Auto</p>	<p>Site : 03CH15-HY Condition : PEAK_74 3m 91200_02294_230630 HORIZONTAL : RBW:1000.000KHz VBW:3000.000KHz SWT:Auto</p>
Avg.	<p>Site : 03CH15-HY Condition : AVG_BE_54 3m 91200_02294_230630 HORIZONTAL : RBW:1000.000KHz VBW:0.300KHz SWT:Auto</p>	<p>Site : 03CH15-HY Condition : AVG_54 3m 91200_02294_230630 HORIZONTAL : RBW:1000.000KHz VBW:0.300KHz SWT:Auto</p>

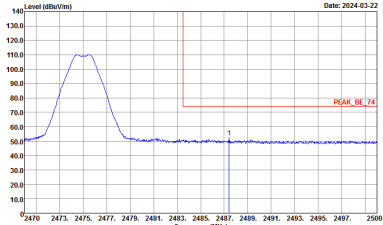
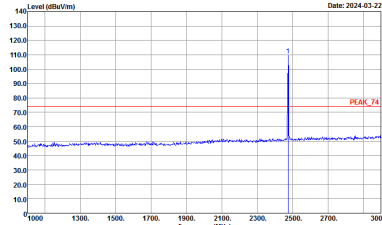
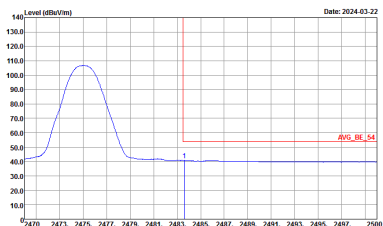
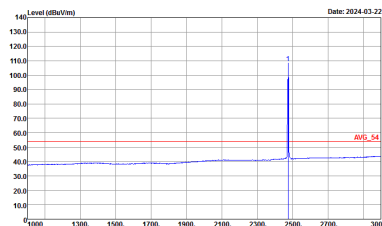

THRE AD	2.4GHz 2400~2483.5MHz Band Edge @ 3m	
ANT	THREAD CH25 2475MHz	
3	Vertical	Fundamental
Peak	 <p>Site : 03CH15-HY Condition : PEAK_BE_74 3m 91200_02294_230630 VERTICAL : RBW:1000.000KHz VBW:3000.000KHz SWT:Auto</p>	 <p>Site : 03CH15-HY Condition : PEAK_74 3m 91200_02294_230630 VERTICAL : RBW:1000.000KHz VBW:3000.000KHz SWT:Auto</p>
Avg.	 <p>Site : 03CH15-HY Condition : AVG_BE_54 3m 91200_02294_230630 VERTICAL : RBW:1000.000KHz VBW:0.300KHz SWT:Auto</p>	 <p>Site : 03CH15-HY Condition : AVG_54 3m 91200_02294_230630 VERTICAL : RBW:1000.000KHz VBW:0.300KHz SWT:Auto</p>

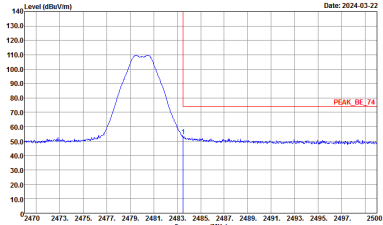
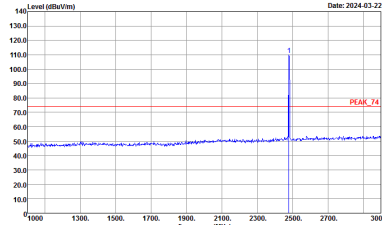
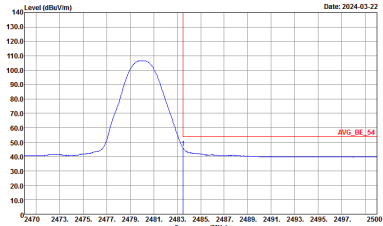
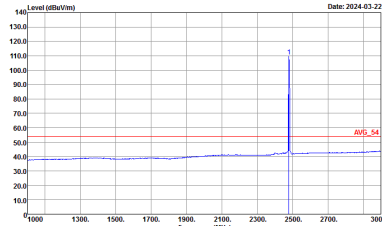

THRE AD	2.4GHz 2400~2483.5MHz Band Edge @ 3m	
ANT	THREAD CH26 2480MHz	
3	Horizontal	Fundamental
Peak	 <p>Level (dBu/Vm) vs Frequency (MHz) plot showing a peak at 2480 MHz. The peak level is approximately 110 dBu/Vm. A red horizontal line indicates the peak level at 74 dBu/Vm.</p> <p>Site : 03CH15-HY Condition : PEAK_BE_74 3m 91200_02294_230630 HORIZONTAL : RBW:1000.000KHz VBW:3000.000KHz SWT:Auto</p>	 <p>Level (dBu/Vm) vs Frequency (MHz) plot showing a sharp peak at 2480 MHz. The peak level is approximately 110 dBu/Vm. A red horizontal line indicates the peak level at 74 dBu/Vm.</p> <p>Site : 03CH15-HY Condition : PEAK_74 3m 91200_02294_230630 HORIZONTAL : RBW:1000.000KHz VBW:3000.000KHz SWT:Auto</p>
Avg.	 <p>Level (dBu/Vm) vs Frequency (MHz) plot showing an averaged peak at 2480 MHz. The peak level is approximately 105 dBu/Vm. A red horizontal line indicates the average level at 54 dBu/Vm.</p> <p>Site : 03CH15-HY Condition : AVG_BE_54 3m 91200_02294_230630 HORIZONTAL : RBW:1000.000KHz VBW:0.300KHz SWT:Auto</p>	 <p>Level (dBu/Vm) vs Frequency (MHz) plot showing an averaged sharp peak at 2480 MHz. The peak level is approximately 105 dBu/Vm. A red horizontal line indicates the average level at 54 dBu/Vm.</p> <p>Site : 03CH15-HY Condition : AVG_54 3m 91200_02294_230630 HORIZONTAL : RBW:1000.000KHz VBW:0.300KHz SWT:Auto</p>

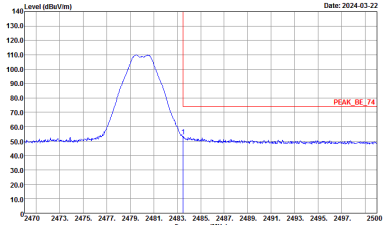
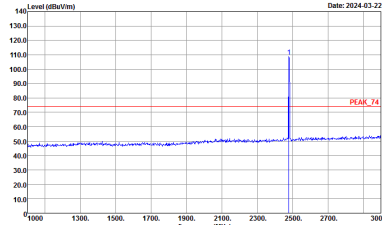
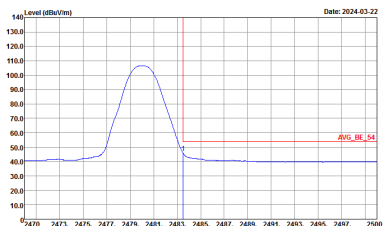
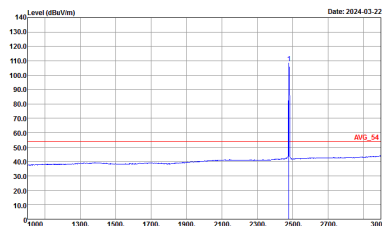

THRE AD	2.4GHz 2400~2483.5MHz Band Edge @ 3m	
ANT	THREAD CH26 2480MHz	
3	Vertical	Fundamental
Peak	 <p>Site : 03CH15-HY Condition : PEAK_BE_74 3m 91200_02294_230630 VERTICAL : RBW:1000.000KHz VBW:3000.000KHz SWT:Auto</p>	 <p>Site : 03CH15-HY Condition : PEAK_74 3m 91200_02294_230630 VERTICAL : RBW:1000.000KHz VBW:3000.000KHz SWT:Auto</p>
Avg.	 <p>Site : 03CH15-HY Condition : AVG_BE_54 3m 91200_02294_230630 VERTICAL : RBW:1000.000KHz VBW:0.300KHz SWT:Auto</p>	 <p>Site : 03CH15-HY Condition : AVG_54 3m 91200_02294_230630 VERTICAL : RBW:1000.000KHz VBW:0.300KHz SWT:Auto</p>



2.4GHz 2400~2483.5MHz
THREAD (Harmonic @ 3m)

THRE	2.4GHz 2400~2483.5MHz Harmonic @ 3m	
AD		
ANT	THREAD CH11 2405MHz	
3	Horizontal	Vertical
Peak Avg.	<p>Site : 03CH15-HV Condition : PEAK_74 3m 91200_02294_230630 HORIZONTAL</p>	<p>Site : 03CH15-HV Condition : PEAK_74 3m 91200_02294_230630 VERTICAL</p>



<p>THRE AD</p>	<p>2.4GHz 2400~2483.5MHz Harmonic @ 3m</p>	
<p>ANT</p>	<p>THREAD CH11 2405MHz</p>	
<p>3</p>	<p>Horizontal</p>	<p>Vertical</p>
<p>14.47G ~14.5G Avg.</p>	<p>Site : 03CH15-HY Condition : AVG_54 3m 91200_02294_230630 HORIZONTAL</p>	<p>Site : 03CH15-HY Condition : AVG_54 3m 91200_02294_230630 VERTICAL</p>
<p>17.7G ~18G Avg.</p>	<p>Site : 03CH15-HY Condition : AVG_54 3m 91200_02294_230630 HORIZONTAL</p>	<p>Site : 03CH15-HY Condition : AVG_54 3m 91200_02294_230630 VERTICAL</p>



THRE AD	2.4GHz 2400~2483.5MHz Harmonic @ 3m	
ANT	THREAD CH18 2440MHz	
3	Horizontal	Vertical
Peak Avg.	<p>Site : 03CH15-14Y Condition : PEAK_74 3m 91200_02294_230630 HORIZONTAL :</p>	<p>Site : 03CH15-14Y Condition : PEAK_74 3m 91200_02294_230630 VERTICAL :</p>



<p>THRE AD</p>	<p>2.4GHz 2400~2483.5MHz Harmonic @ 3m</p>	
<p>ANT</p>	<p>THREAD CH18 2440MHz</p>	
<p>3</p>	<p>Horizontal</p>	<p>Vertical</p>
<p>14.47G ~14.5G Avg.</p>	<p>Site : 03CH15-HY Condition : AVG_54 3m 91200_02294_230630 HORIZONTAL</p>	<p>Site : 03CH15-HY Condition : AVG_54 3m 91200_02294_230630 VERTICAL</p>
<p>17.7G ~18G Avg.</p>	<p>Site : 03CH15-HY Condition : AVG_54 3m 91200_02294_230630 HORIZONTAL</p>	<p>Site : 03CH15-HY Condition : AVG_54 3m 91200_02294_230630 VERTICAL</p>



THRE	2.4GHz 2400~2483.5MHz Harmonic @ 3m	
AD		
ANT	THREAD CH25 2475MHz	
3	Horizontal	Vertical
Peak	<p>Site : 03CH15-14Y Condition : PEAK_74 3m 91200_02294_230630 HORIZONTAL</p>	<p>Site : 03CH15-14Y Condition : PEAK_74 3m 91200_02294_230630 VERTICAL</p>



THRE AD	2.4GHz 2400~2483.5MHz Harmonic @ 3m	
ANT	THREAD CH25 2475MHz	
3	Horizontal	Vertical
14.47G ~14.5G Avg.	<p>Site : 03CH15-HY Condition : AVG_54 3m 91200_02294_230630 HORIZONTAL</p>	<p>Site : 03CH15-HY Condition : AVG_54 3m 91200_02294_230630 VERTICAL</p>
17.7G ~18G Avg.	<p>Site : 03CH15-HY Condition : AVG_54 3m 91200_02294_230630 HORIZONTAL</p>	<p>Site : 03CH15-HY Condition : AVG_54 3m 91200_02294_230630 VERTICAL</p>



THRE	2.4GHz 2400~2483.5MHz Harmonic @ 3m	
AD		
ANT	THREAD CH26 2480MHz	
3	Horizontal	Vertical
Peak	<p>Site : 03CH15-14Y Condition : PEAK_74 3m 91200_02294_230630 HORIZONTAL</p>	<p>Site : 03CH15-14Y Condition : PEAK_74 3m 91200_02294_230630 VERTICAL</p>



<p>THRE AD</p>	<p>2.4GHz 2400~2483.5MHz Harmonic @ 3m</p>	
<p>ANT</p>	<p>THREAD CH26 2480MHz</p>	
<p>3</p>	<p>Horizontal</p>	<p>Vertical</p>
<p>14.47G ~14.5G Avg.</p>	<p>Site : 03CH15-HY Condition : AVG_54 3m 91200_02294_230630 HORIZONTAL</p>	<p>Site : 03CH15-HY Condition : AVG_54 3m 91200_02294_230630 VERTICAL</p>
<p>17.7G ~18G Avg.</p>	<p>Site : 03CH15-HY Condition : AVG_54 3m 91200_02294_230630 HORIZONTAL</p>	<p>Site : 03CH15-HY Condition : AVG_54 3m 91200_02294_230630 VERTICAL</p>



Emission above 18GHz
2.4GHz THREAD (SHF @ 1m)

THRE	2.4GHz 2400~2483.5MHz	
AD		
ANT	THREAD SHF	
3	Horizontal	Vertical
Peak Avg.	<p>Site : 03CH15-HY Condition : PEAK_74 1m SHF_993_231124 HORIZONTAL</p>	<p>Site : 03CH16-HY Condition : PEAK_74 1m SHF_993_231124 VERTICAL</p>



Emission below 1GHz
2.4GHz THREAD (LF)

THRE	2.4GHz 2400~2483.5MHz	
AD		
ANT	THREAD LF	
3	Horizontal	Vertical
QP / Peak	<p>Site : 03CH15-HV Condition : QP-3m 81L06_20240203_1G-HORIZONTAL</p>	<p>Site : 03CH15-HV Condition : QP-3m 81L06_20240203_1G-VERTICAL</p>



Appendix E. Duty Cycle Plots

Antenna	Band	Duty Cycle(%)	T(us)	1/T(kHz)	VBW Setting
3	Thread - 250kbps	90.13	4245	0.24	300Hz

<Ant. 3>

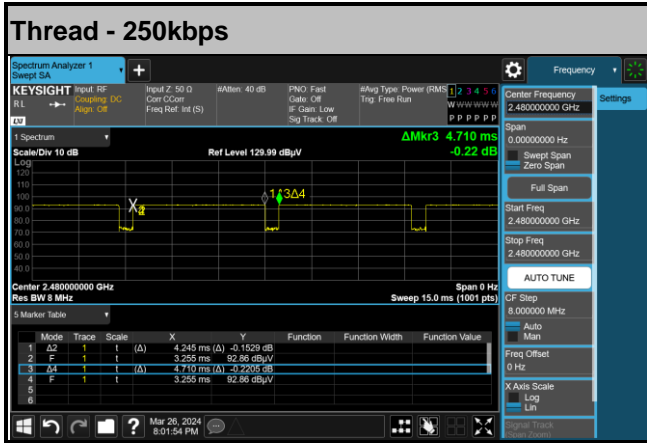

—THE END—