



FCC RADIO TEST REPORT

FCC ID : A4RGD1YQ
Equipment : Phone
Model Name : GD1YQ
Applicant : Google LLC
1600 Amphitheatre Parkway,
Mountain View, California, 94043 USA
Standard : FCC Part 15 Subpart E §15.407

The product was received on Apr. 16, 2020 and testing was started from May 06, 2020 and completed on Jul. 03, 2020. We, SPORTON INTERNATIONAL INC., EMC & Wireless Communications Laboratory, would like to declare that the tested sample has been evaluated in accordance with the test procedures and has been in compliance with the applicable technical standards.

The test results in this report apply exclusively to the tested model / sample. Without written approval of SPORTON INTERNATIONAL INC. EMC & Wireless Communications Laboratory, the test report shall not be reproduced except in full.

Louis Wu

Approved by: Louis Wu

SPORTON INTERNATIONAL INC. EMC & Wireless Communications Laboratory
No. 52, Huaya 1st Rd., Guishan Dist., Taoyuan City, Taiwan (R.O.C.)



Table of Contents

History of this test report.....	3
Summary of Test Result.....	4
1 General Description	5
1.1 Product Feature of Equipment Under Test.....	5
1.2 Product Specification of Equipment Under Test.....	6
1.3 Modification of EUT	8
1.4 Testing Location	8
1.5 Applicable Standards.....	8
2 Test Configuration of Equipment Under Test	9
2.1 Carrier Frequency and Channel	9
2.2 Test Mode.....	10
2.3 Connection Diagram of Test System.....	12
2.4 Support Unit used in test configuration and system	13
2.5 EUT Operation Test Setup	14
2.6 Measurement Results Explanation Example.....	14
3 Test Result	15
3.1 26dB & 99% Occupied Bandwidth Measurement	15
3.2 Maximum Conducted Output Power Measurement	17
3.3 Power Spectral Density Measurement	19
3.4 Unwanted Emissions Measurement.....	21
3.5 AC Conducted Emission Measurement.....	26
3.6 Automatically Discontinue Transmission	28
3.7 Antenna Requirements	30
4 List of Measuring Equipment.....	31
5 Uncertainty of Evaluation.....	33
Appendix A. Conducted Test Results	
Appendix B. AC Conducted Emission Test Result	
Appendix C. Radiated Spurious Emission	
Appendix D. Radiated Spurious Emission Plots	
Appendix E. Duty Cycle Plots	



History of this test report

Report No.	Version	Description	Issued Date
FR011718-01E	01	Initial issue of report	Jul. 13, 2020
FR011718-01E	02	Revise maximum output power	Aug. 11, 2020



Summary of Test Result

Report Clause	Ref Std. Clause	Test Items	Result (PASS/FAIL)	Remark
3.1	15.403(i)	26dB Bandwidth	Pass	-
3.1	2.1049	99% Occupied Bandwidth	Reporting only	-
3.2	15.407(a)	Maximum Conducted Output Power	Pass	-
3.3	15.407(a)	Power Spectral Density	Pass	-
3.4	15.407(b)	Unwanted Emissions	Pass	Under limit 1.58 dB at 5470.000 MHz
3.5	15.207	AC Conducted Emission	Pass	Under limit 11.36 dB at 0.205 MHz
3.6	15.407(c)	Automatically Discontinue Transmission	Pass	-
3.7	15.203 15.407(a)	Antenna Requirement	Pass	-

Declaration of Conformity:

The test results with all measurement uncertainty excluded are presented in accordance with the regulation limits or requirements declared by manufacturers.

Comments and Explanations:

The declared of product specification for EUT presented in the report are provided by the manufacturer, and the manufacturer takes all the responsibilities for the accuracy of product specification.

Reviewed by: Wii Chang

Report Producer: Amy Chen



1 General Description

1.1 Product Feature of Equipment Under Test

Product Feature	
Equipment	Phone
Model Name	GD1YQ
FCC ID	A4RGD1YQ
EUT supports Radios application	CDMA/EV-DO/GSM/EGPRS/WCDMA/HSPA/LTE/5G NR/ NFC/GNSS/WPC/WPT WLAN 11b/g/n HT20 WLAN 11a/n HT20/HT40 WLAN 11ac VHT20/VHT40/VHT80 Bluetooth BR/EDR/LE

Remark: The above EUT's information was declared by manufacturer.

EUT Information List	
S/N	Performed Test Item
06021FDD40012C	RF Conducted Measurement
03281FDD4000BB	Radiated Spurious Emission
03311FDD40001W	Conducted Emission

1.2 Product Specification of Equipment Under Test

Standards-related Product Specification	
Tx/Rx Frequency Range	5180 MHz ~ 5240 MHz 5260 MHz ~ 5320 MHz 5500 MHz ~ 5720 MHz
Maximum Output Power	<p><5180 MHz ~ 5240 MHz></p> <p><Ant. 4> 802.11a : 17.40 dBm / 0.0550 W 802.11n HT20 : 17.50 dBm / 0.0562 W 802.11n HT40 : 20.30 dBm / 0.1072 W 802.11ac VHT20: 17.40 dBm / 0.0550 W 802.11ac VHT40: 20.20 dBm / 0.1047 W 802.11ac VHT80: 12.30 dBm / 0.0170 W</p> <p><Ant. 3> 802.11a : 18.10 dBm / 0.0646 W 802.11n HT20 : 18.10 dBm / 0.0646 W 802.11n HT40 : 19.90 dBm / 0.0977 W 802.11ac VHT20: 18.00 dBm / 0.0631 W 802.11ac VHT40: 19.80 dBm / 0.0955 W 802.11ac VHT80: 12.10 dBm / 0.0162 W</p> <p>MIMO <Ant. 4 + 3> 802.11a : 20.73 dBm / 0.1183 W 802.11n HT20 : 20.73 dBm / 0.1183 W 802.11n HT40 : 23.11 dBm / 0.2046 W 802.11ac VHT20: 20.63 dBm / 0.1156 W 802.11ac VHT40: 23.01 dBm / 0.2000 W 802.11ac VHT80: 15.21 dBm / 0.0332 W</p> <p><5260 MHz ~ 5320 MHz></p> <p><Ant. 4> 802.11a : 17.40 dBm / 0.0550 W 802.11n HT20 : 18.00 dBm / 0.0631 W 802.11n HT40 : 20.30 dBm / 0.1072 W 802.11ac VHT20: 17.90 dBm / 0.0617 W 802.11ac VHT40: 20.20 dBm / 0.1047 W 802.11ac VHT80: 12.00 dBm / 0.0158 W</p> <p><Ant. 3> 802.11a : 16.70 dBm / 0.0468 W 802.11n HT20 : 17.80 dBm / 0.0603 W 802.11n HT40 : 19.90 dBm / 0.0977 W 802.11ac VHT20: 17.70 dBm / 0.0589 W 802.11ac VHT40: 19.80 dBm / 0.0955 W 802.11ac VHT80: 11.10 dBm / 0.0129 W</p> <p>MIMO <Ant. 4 + 3> 802.11a : 20.07 dBm / 0.1016 W 802.11n HT20 : 20.91 dBm / 0.1233 W 802.11n HT40 : 23.11 dBm / 0.2046 W 802.11ac VHT20: 20.81 dBm / 0.1205 W 802.11ac VHT40: 23.01 dBm / 0.2000 W 802.11ac VHT80: 14.58 dBm / 0.0287 W</p>



Standards-related Product Specification										
Maximum Output Power	<p><5500 MHz ~ 5720 MHz> <Ant. 4> 802.11a : 17.20 dBm / 0.0525 W 802.11n HT20 : 17.40 dBm / 0.0550 W 802.11n HT40 : 20.00 dBm / 0.1000 W 802.11ac VHT20: 17.30 dBm / 0.0537 W 802.11ac VHT40: 19.90 dBm / 0.0977 W 802.11ac VHT80: 19.90 dBm / 0.0977 W <Ant. 3> 802.11a : 17.80 dBm / 0.0603 W 802.11n HT20 : 17.90 dBm / 0.0617 W 802.11n HT40 : 20.90 dBm / 0.1230 W 802.11ac VHT20: 17.80 dBm / 0.0603 W 802.11ac VHT40: 20.80 dBm / 0.1202 W 802.11ac VHT80: 20.80 dBm / 0.1202 W MIMO <Ant. 4 + 3> 802.11a : 20.47 dBm / 0.1114 W 802.11n HT20 : 20.91 dBm / 0.1233 W 802.11n HT40 : 23.40 dBm / 0.2188 W 802.11ac VHT20: 20.53 dBm / 0.1130 W 802.11ac VHT40: 23.30 dBm / 0.2138 W 802.11ac VHT80: 23.38 dBm / 0.2178 W</p>									
99% Occupied Bandwidth	<p>MIMO <Ant. 4> 802.11a : 17.55 MHz 802.11n HT20 : 20.75 MHz 802.11n HT40 : 38.60 MHz 802.11ac VHT80: 77.28 MHz MIMO <Ant. 3> 802.11a : 18.50 MHz 802.11n HT20 : 19.25 MHz 802.11n HT40 : 37.30 MHz 802.11ac VHT80: 77.40 MHz</p>									
Type of Modulation	802.11a/n : OFDM (BPSK / QPSK / 16QAM / 64QAM) 802.11ac : OFDM (BPSK / QPSK / 16QAM / 64QAM / 256QAM)									
Antenna Type / Gain	<p><5180 MHz ~ 5240 MHz> <Ant. 4>: ILA Antenna with gain -2.30 dBi <Ant. 3>: Loop Antenna with gain -3.40 dBi <5260 MHz ~ 5320 MHz> <Ant. 4>: ILA Antenna with gain -2.30 dBi <Ant. 3>: Loop Antenna with gain -3.40 dBi <5500 MHz ~ 5720 MHz> <Ant. 4>: ILA Antenna with gain -1.90 dBi <Ant. 3>: Loop Antenna with gain -5.80 dBi</p>									
Antenna Function Description	<table border="1"> <thead> <tr> <th></th> <th>Ant. 4</th> <th>Ant. 3</th> </tr> </thead> <tbody> <tr> <td>802.11 a/n/ac</td> <td>√</td> <td>√</td> </tr> <tr> <td>802.11 a/n/ac MIMO</td> <td>√</td> <td>√</td> </tr> </tbody> </table>		Ant. 4	Ant. 3	802.11 a/n/ac	√	√	802.11 a/n/ac MIMO	√	√
	Ant. 4	Ant. 3								
802.11 a/n/ac	√	√								
802.11 a/n/ac MIMO	√	√								

Note: MIMO Ant. 4+3 is a calculated result from sum of the power MIMO Ant. 4 and MIMO Ant. 3.



1.3 Modification of EUT

No modifications are made to the EUT during all test items.

1.4 Testing Location

Test Site	SPORTON INTERNATIONAL INC. EMC & Wireless Communications Laboratory	
Test Site Location	No.52, Huaya 1st Rd., Guishan Dist., Taoyuan City, Taiwan (R.O.C.) TEL: +886-3-327-3456 FAX: +886-3-328-4978	
Test Site No.	Sporton Site No.	
	TH05-HY	CO05-HY

Note: The test site complies with ANSI C63.4 2014 requirement.

Test Site	SPORTON INTERNATIONAL INC. EMC & Wireless Communications Laboratory	
Test Site Location	No.58, Aly. 75, Ln. 564, Wenhua 3rd, Rd., Guishan Dist., Taoyuan City, Taiwan (R.O.C.) TEL: +886-3-327-0868 FAX: +886-3-327-0855	
Test Site No.	Sporton Site No.	
	03CH16-HY	

Note: The test site complies with ANSI C63.4 2014 requirement.

FCC designation No.: TW1190 and TW0007

1.5 Applicable Standards

According to the specifications of the manufacturer, the EUT must comply with the requirements of the following standards:

- ♦ FCC Part 15 Subpart E
- ♦ FCC KDB 789033 D02 General UNII Test Procedures New Rules v02r01.
- ♦ FCC KDB 414788 D01 Radiated Test Site v01r01.
- ♦ FCC KDB 662911 D01 Multiple Transmitter Output v02r01.
- ♦ ANSI C63.10-2013

Remark:

1. All test items were verified and recorded according to the standards and without any deviation during the test.
2. The TAF code is not including all the FCC KDB listed without accreditation.
3. This EUT has also been tested and complied with the requirements of FCC Part 15, Subpart B, recorded in a separate test report.



2 Test Configuration of Equipment Under Test

- a. The EUT has been associated with peripherals and configuration operated in a manner tended to maximize its emission characteristics in a typical application. Frequency range investigated: conduction emission (150 kHz to 30 MHz), radiation emission (9 kHz to the 10th harmonic of the highest fundamental frequency or to 40 GHz, whichever is lower). For radiated measurement, pre-scanned in three orthogonal panels, X, Y, Z and Accessory (Adapter or Earphone). The worst cases (Z plane with Adapter and WPC Mode) were recorded in this report.
- b. AC power line Conducted Emission was tested under maximum output power.

2.1 Carrier Frequency and Channel

Frequency Band	Channel	Freq. (MHz)	Channel	Freq. (MHz)
5150-5250 MHz Band 1 (U-NII-1)	36	5180	44	5220
	38*	5190	46*	5230
	40	5200	48	5240
	42 [#]	5210		

Frequency Band	Channel	Freq. (MHz)	Channel	Freq. (MHz)
5250-5350 MHz Band 2 (U-NII-2A)	52	5260	60	5300
	54*	5270	62*	5310
	56	5280	64	5320
	58 [#]	5290		

Frequency Band	Channel	Freq. (MHz)	Channel	Freq. (MHz)
5470-5725 MHz Band 3 (U-NII-2C)	100	5500	112	5560
	102*	5510	116	5580
	104	5520	132	5660
	106 [#]	5530	134*	5670
	108	5540	136	5680
	110*	5550	140	5700



Frequency Band	Channel	Freq. (MHz)	Channel	Freq. (MHz)
TDWR Channel	118*	5590	124	5620
	120	5600	126*	5630
	122 [#]	5610	128	5640

Frequency Band	Channel	Freq. (MHz)	Channel	Freq. (MHz)
Straddle Channel	138 [#]	5690	144	5720
	142*	5710		

Note:

1. The above Frequency and Channel in "*" were 802.11n HT40 and 802.11ac VHT40.
2. The above Frequency and Channel in "[#]" were 802.11ac VHT80.

2.2 Test Mode

Final test modes are considering the modulation and worse data rates as below table.

Modulation	Data Rate
802.11a	6 Mbps
802.11n HT20	MCS0
802.11n HT40	MCS0
802.11ac VHT20 (Covered by HT20)	MCS0
802.11ac VHT40 (Covered by HT40)	MCS0
802.11ac VHT80	MCS0

Test Cases	
AC Conducted Emission	Mode 1 : GSM850 Idle + WLAN (5GHz) Link + Bluetooth Link + USB Cable (Charging from Adapter 2)
Remark: For Radiated Test Cases, the tests were performed with Adapter 2.	



Ch. #		Band I : 5150-5250 MHz	Band II : 5250-5350 MHz	Band III : 5470-5725MHz
		802.11a	802.11a	802.11a
L	Low	36	52	100
M	Middle	44	60	116
H	High	48	64	140
Straddle		-	-	144

Ch. #		Band I : 5150-5250 MHz	Band II : 5250-5350 MHz	Band III : 5470-5725MHz
		802.11n HT20	802.11n HT20	802.11n HT20
L	Low	36	52	100
M	Middle	44	60	116
H	High	48	64	140
Straddle		-	-	144

Ch. #		Band I : 5150-5250 MHz	Band II : 5250-5350 MHz	Band III : 5470-5725MHz
		802.11n HT40	802.11n HT40	802.11n HT40
L	Low	38	54	102
M	Middle	-	-	110
H	High	46	62	134
Straddle		-	-	142

Ch. #		Band I : 5150-5250 MHz	Band II : 5250-5350 MHz	Band III : 5470-5725MHz
		802.11ac VHT80	802.11ac VHT80	802.11ac VHT80
L	Low	-	-	106
M	Middle	42	58	122
H	High	-	-	-
Straddle		-	-	138

Remark: For radiation spurious emission, the final modulation and the worst data rate was reference the max RF conducted power.

2.3 Connection Diagram of Test System

<AC Conducted Emissions Mode>

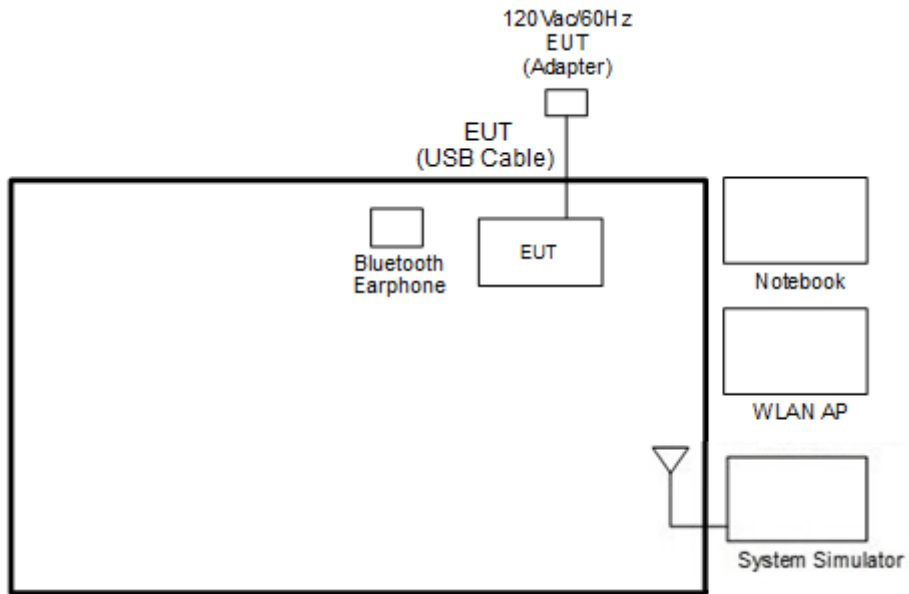

<WLAN Tx Mode>

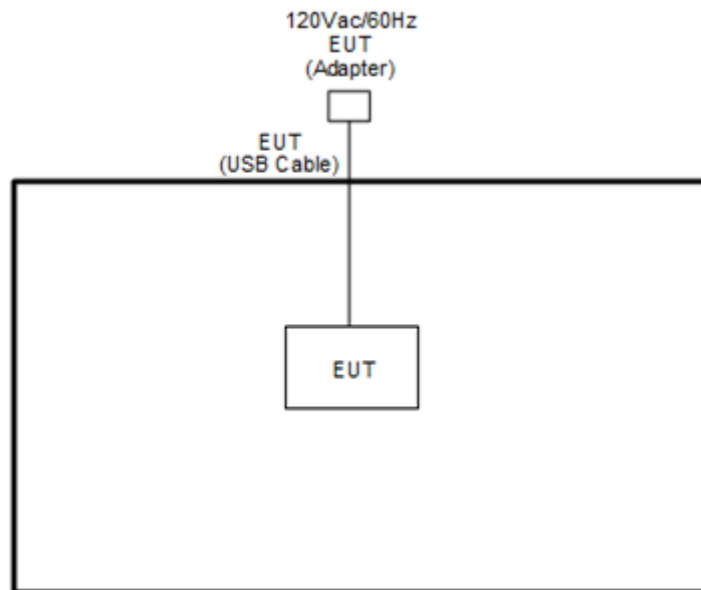

<WPC Mode>

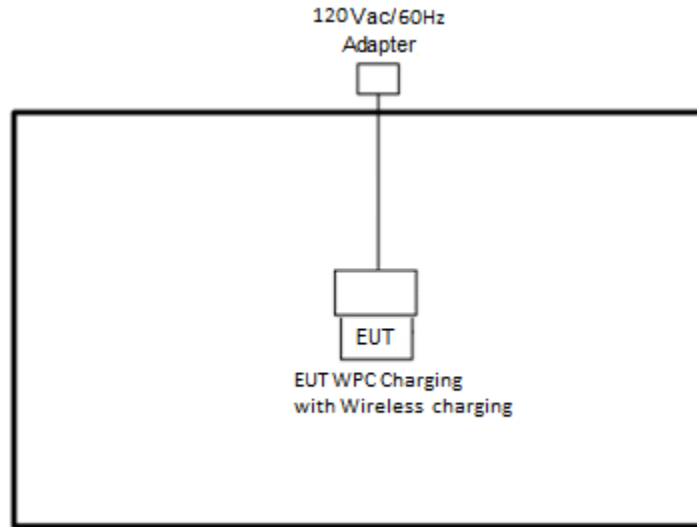

2.4 Support Unit used in test configuration and system

Item	Equipment	Trade Name	Model Name	FCC ID	Data Cable	Power Cord
1.	System Simulator	Anritsu	MT8820C	N/A	N/A	Unshielded, 1.8 m
2.	Bluetooth Earphone	Google	G1007/ G1008	A4RG1007	N/A	N/A
3.	WLAN AP	ASUS	RT-AC66U	MSQ-RTAC66U	N/A	Unshielded, 1.8 m
4.	Notebook	DELL	Latitude 3400	FCC DoC	N/A	AC I/P: Unshielded, 1.2 m DC O/P: Shielded, 1.8 m
5.	Wireless charging	YU-live	K8	N/A	N/A	N/A



2.5 EUT Operation Test Setup

The RF test items, utility “QRCT V4.0.00153.0” was installed in Notebook which was programmed in order to make the EUT get into the engineering modes to provide channel selection, power level, data rate and the application type and for continuous transmitting signals.

2.6 Measurement Results Explanation Example

For all conducted test items:

The offset level is set in the spectrum analyzer to compensate the RF cable loss and attenuator factor between EUT conducted output port and spectrum analyzer. With the offset compensation, the spectrum analyzer reading level is exactly the EUT RF output level.

Example :

The spectrum analyzer offset is derived from RF cable loss and attenuator factor.

Offset = RF cable loss + attenuator factor.

Following shows an offset computation example with cable loss 4.2 dB and 10dB attenuator.

$$\begin{aligned} \text{Offset(dB)} &= \text{RF cable loss(dB)} + \text{attenuator factor(dB)}. \\ &= 4.2 + 10 = 14.2 \text{ (dB)} \end{aligned}$$

3 Test Result

3.1 26dB & 99% Occupied Bandwidth Measurement

3.1.1 Description of 26dB & 99% Occupied Bandwidth

This section is for reporting purpose only.

There is no restriction limits for bandwidth.

For Straddle Channel, according to KDB 789033 D02 General UNII Test Procedures New Rules v02r01, if the power and PSD of the devices are uniform and comply with the lower limits specified for the U-NII-2 bands, a single measurement over the entire emission bandwidth can be performed to show compliance.

3.1.2 Measuring Instruments

See list of measuring equipment of this test report.

3.1.3 Test Procedures

1. The testing follows FCC KDB 789033 D02 General UNII Test Procedures New Rules v02r01. Section C) Emission bandwidth
2. Set RBW = approximately 1% of the emission bandwidth.
3. Set the VBW > RBW.
4. Detector = Peak.
5. Trace mode = max hold
6. Measure the maximum width of the emission that is 26 dB down from the peak of the emission. Compare this with the RBW setting of the analyzer. Readjust RBW and repeat measurement as needed until the RBW/EBW ratio is approximately 1%.
7. For 99% Bandwidth Measurement, the spectrum analyzer's resolution bandwidth (RBW) is set 1-5% of the emission bandwidth and set the Video bandwidth (VBW) $\geq 3 * RBW$.
8. Measure and record the results in the test report.

3.1.4 Test Setup

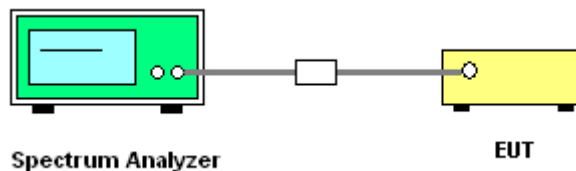

3.1.5 Test Result of 26dB & 99% Occupied Bandwidth

Please refer to Appendix A.

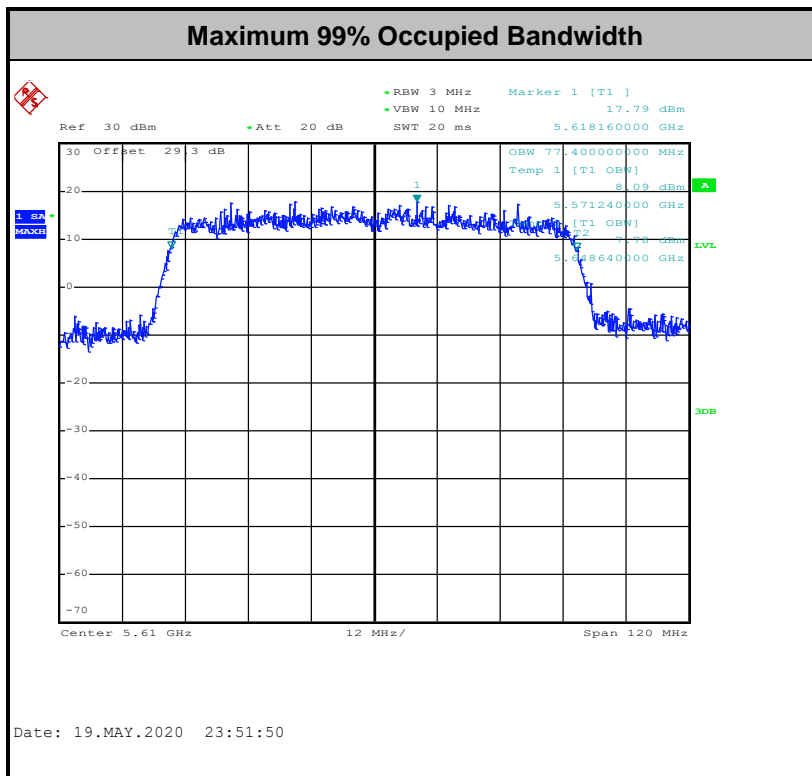
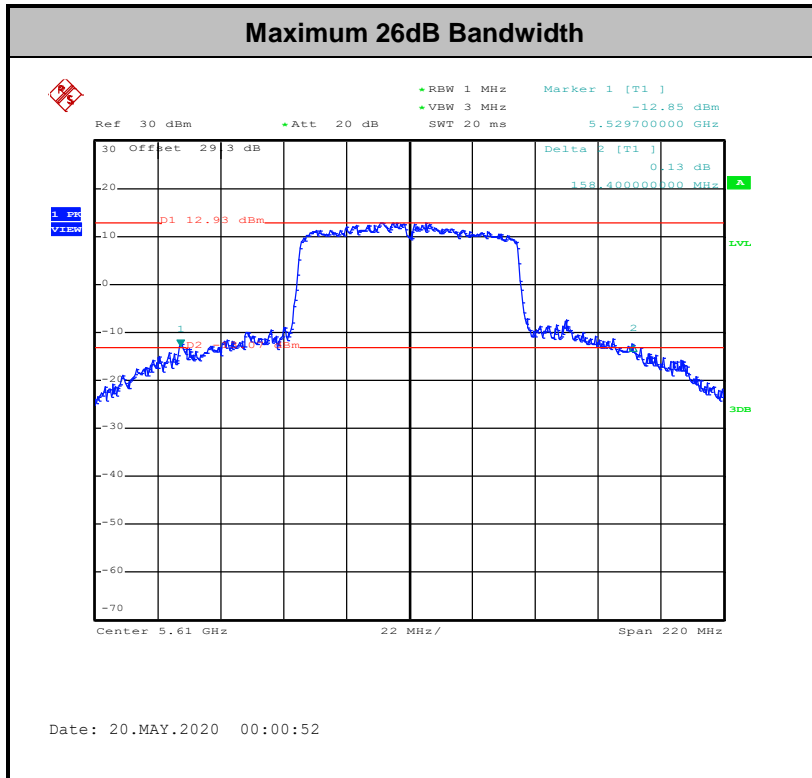

Note: The occupied channel bandwidth is maintained within the band of operation for all of the modulations.



3.2 Maximum Conducted Output Power Measurement

3.2.1 Limit of Maximum Conducted Output Power

<FCC 14-30 CFR 15.407>

For the 5.15–5.25 GHz bands:

- For mobile and portable client devices in the 5.15–5.25 GHz band, the maximum conducted output power over the frequency band of operation shall not exceed 250 mW. For an indoor access point operating in the band 5.15-5.25 GHz, the maximum conducted output power over the frequency band of operation shall not exceed 1 W.

For the 5.25–5.725 GHz bands:

- The maximum conducted output power over the frequency bands of operation shall not exceed the lesser of 250 mW or $11 \text{ dBm} + 10 \log B$, where B is the 26 dB emission bandwidth in megahertz.

For Straddle Channel, according to KDB 789033 D02 General UNII Test Procedures New Rules v02r01, if the power and PSD of the devices are uniform and comply with the lower limits specified for the U-NII-2 bands, a single measurement over the entire emission bandwidth can be performed to show compliance.

If transmitting antennas of directional gain greater than 6 dBi are used, the peak output power shall be reduced by the amount in dB that the directional gain of the antenna exceeds 6 dBi.

Note that U-NII-2 band, devices with a maximum e.i.r.p. greater than 500 mW shall implement TPC in order to have the capability to operate at least 6 dB below the maximum permitted e.i.r.p. of 1 W.

3.2.2 Measuring Instruments

See list of measuring equipment of this test report.

3.2.3 Test Procedures

The testing follows Method PM-G of FCC KDB 789033 D02 General UNII Test Procedures New Rules v02r01.

Method PM-G (Measurement using an RF average power meter):

1. Measurement is performed using a wideband RF power meter.
2. The EUT is configured to transmit at its maximum power control level.
3. Measure the average power of the transmitter
4. Since the measurement is made only during the ON time of the transmitter, no duty cycle correction factor is required.

For Straddle Channel, according to KDB 789033 D02 General UNII Test Procedures New Rules v02r01, if the power and PSD of the devices are uniform and comply with the lower limits specified for the U-NII-2 bands, a single measurement over the entire emission bandwidth can be performed to show compliance.

3.2.4 Test Setup

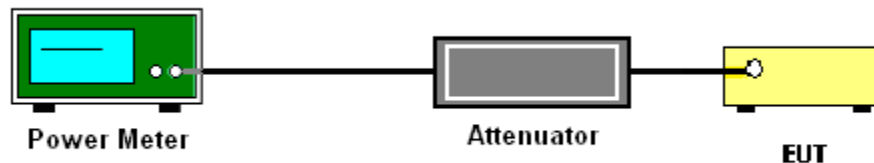

3.2.5 Test Result of Maximum Conducted Output Power

Please refer to Appendix A.



3.3 Power Spectral Density Measurement

3.3.1 Limit of Power Spectral Density

<FCC 14-30 CFR 15.407>

For the 5.15–5.25 GHz bands:

For mobile and portable client devices in the 5.15–5.25 GHz band, the maximum power spectral density shall not exceed 11 dBm in any 1.0 MHz band. For an indoor access point operating in the band 5.15-5.25 GHz, the maximum power spectral density shall not exceed 17 dBm in any 1.0 MHz band.

For the 5.25–5.725 GHz bands:

The maximum power spectral density shall not exceed 11 dBm in any 1.0 MHz band.

For Straddle Channel, according to KDB 789033 D02 General UNII Test Procedures New Rules v02r01, if the power and PSD of the devices are uniform and comply with the lower limits specified for the U-NII-2 bands, a single measurement over the entire emission bandwidth can be performed to show compliance.

If transmitting antennas of directional gain greater than 6 dBi are used, the peak output power shall be reduced by the amount in dB that the directional gain of the antenna exceeds 6 dBi.

3.3.2 Measuring Instruments

See list of measuring equipment of this test report.

3.3.3 Test Procedures

The testing follows FCC KDB 789033 D02 General UNII Test Procedures New Rules v02r01. Section F) Maximum power spectral density.

Method SA-3

(power averaging (rms) detection with max hold):

- Set span to encompass the entire emission bandwidth (EBW) of the signal.
- Set RBW = 1 MHz.
- Set VBW \geq 3 MHz
- Number of points in sweep \geq 2 Span / RBW.
- Sweep time \leq (number of points in sweep) \times T, when duty cycle is less than 98 percent where T is the minimum transmission duration over which the transmitter is on and is transmitting at its maximum power control level for the tested mode of operation.
- Detector = power averaging (rms).
- Trace mode = max hold.
- Allow max hold to run for at least 60 seconds, or longer as needed to allow the trace to stabilize.

1. The RF output of EUT was connected to the spectrum analyzer by a low loss cable.
2. Each plot has already offset with cable loss, and attenuator loss. Measure the PPSD and record it.
3. For MIMO mode, calculation method follows FCC KDB 662911 D01 Multiple Transmitter Output v02r01.

Method (a): Measure and sum the spectra across the outputs.

The total final Power Spectral Density is from a device with 2 transmitter outputs. The spectrum measurements of the individual outputs are all performed with the same span and number of points; the spectrum value in the first spectral bin of output 1 is summed with that in the first spectral bin of output 2 to obtain the value for the first frequency bin of the summed spectrum.

3.3.4 Test Setup

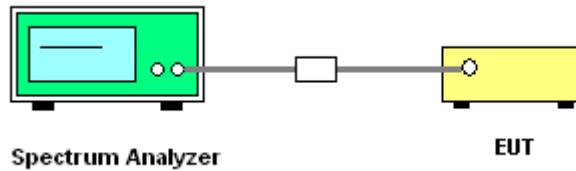

3.3.5 Test Result of Power Spectral Density

Please refer to Appendix A.

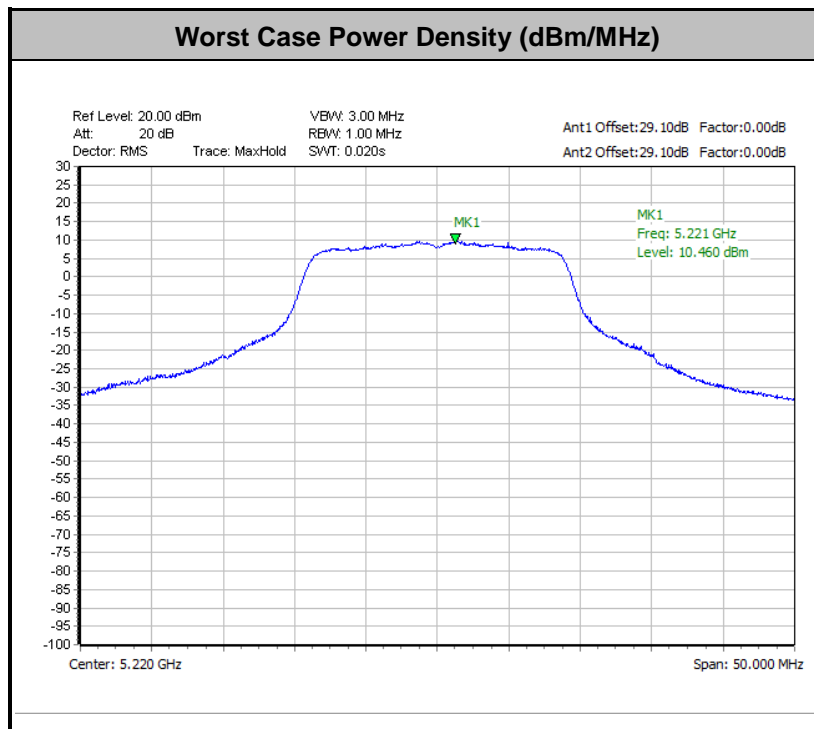



3.4 Unwanted Emissions Measurement

This section is to measure unwanted emissions through radiated measurement for band edge spurious emissions and out of band emissions measurement.

3.4.1 Limit of Unwanted Emissions

- (1) For transmitters operating in the 5150-5250 MHz band: all emissions outside of the 5150-5350 MHz band shall not exceed an EIRP of -27dBm/MHz.

For transmitters operating in the 5250-5350 MHz band: all emissions outside of the 5150-5350 MHz band shall not exceed an EIRP of -27 dBm/MHz. Devices operating in the 5250-5350 MHz band that generate emissions in the 5150-5250 MHz band must meet all applicable technical requirements for operation in the 5150-5250 MHz band (including indoor use) or alternatively meet an out-of-band emission EIRP limit of -27 dBm/MHz in the 5150-5250 MHz band.

For transmitters operating in the 5470-5600 MHz and 5650-5725MHz band: all emissions outside of the 5470-5600 MHz and 5650-5725MHz band shall not exceed an EIRP of -27 dBm/MHz.

- (2) Unwanted spurious emissions fallen in restricted bands shall comply with the general field strength limits as below table:

Frequency (MHz)	Field Strength (microvolts/meter)	Measurement Distance (meters)
0.009 – 0.490	2400/F(kHz)	300
0.490 – 1.705	24000/F(kHz)	30
1.705 – 30.0	30	30
30 – 88	100	3
88 – 216	150	3
216 - 960	200	3
Above 960	500	3

Note: The following formula is used to convert the EIRP to field strength.

$$E = \frac{1000000\sqrt{30P}}{3} \mu\text{V/m, where P is the eirp (Watts)}$$



EIRP (dBm)	Field Strength at 3m (dBμV/m)
- 27	68.3

(3) KDB789033 D02 v02r01 G)2)c)

- (i) Sections 15.407(b)(1-3) specifies the unwanted emissions limit for the U-NII-1 and U-NII-2 bands. As specified, emissions above 1000 MHz that are outside of the restricted bands are subject to a peak emission limit of -27 dBm/MHz.
- (ii) Section 15.407(b)(4) specifies the unwanted emissions limit for the U-NII-3 band. A band emissions mask is specified in Section 15.407(b)(4)(i). The emission limits are based on the use of a peak detector.

3.4.2 Measuring Instruments

See list of measuring equipment of this test report.

3.4.3 Test Procedures

1. The testing follows FCC KDB 789033 D02 General UNII Test Procedures New Rules v02r01. Section G) Unwanted emissions measurement.

(1) Procedure for Unwanted Emissions Measurements Below 1000MHz

- RBW = 120 kHz
- VBW = 300 kHz
- Detector = Peak
- Trace mode = max hold

(2) Procedure for Peak Unwanted Emissions Measurements Above 1000 MHz

- RBW = 1 MHz
- VBW ≥ 3 MHz
- Detector = Peak
- Sweep time = auto
- Trace mode = max hold

(3) Procedures for Average Unwanted Emissions Measurements Above 1000MHz

- RBW = 1 MHz
- VBW = 10 Hz, when duty cycle is no less than 98 percent.
- VBW ≥ 1/T, when duty cycle is less than 98 percent where T is the minimum transmission duration over which the transmitter is on and is transmitting at its maximum power control level for the tested mode of operation.

2. The EUT was placed on a turntable with 0.8 meter for frequency below 1GHz and 1.5 meter for frequency above 1GHz respectively above ground.
3. The EUT was set 3 meters from the interference receiving antenna which was mounted on the top of a variable height antenna tower.
4. The antenna is a broadband antenna and its height is adjusted between one meter and four meters above ground to find the maximum value of the field strength for both horizontal polarization and vertical polarization of the antenna.
5. For each suspected emission, the EUT was arranged to its worst case and then adjust the antenna tower (from 1 m to 4 m) and turntable (from 0 degree to 360 degrees) to find the maximum reading.
6. For testing below 1GHz, if the emission level of the EUT in peak mode was 3 dB lower than the limit specified, then peak values of EUT will be reported, otherwise, the emissions will be repeated one by one using the CISPR quasi-peak method and reported.
7. For testing above 1GHz, the emission level of the EUT in peak mode was 20dB lower than average limit (that means the emission level in average mode also complies with the limit in average mode), then peak values of EUT will be reported, otherwise, the emissions will be measured in average mode again and reported.

3.4.4 Test Setup

For radiated emissions below 30MHz

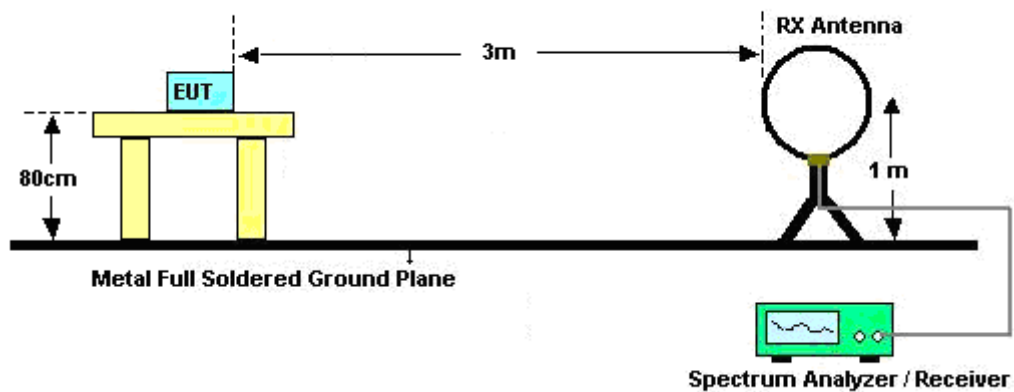

For radiated emissions from 30MHz to 1GHz

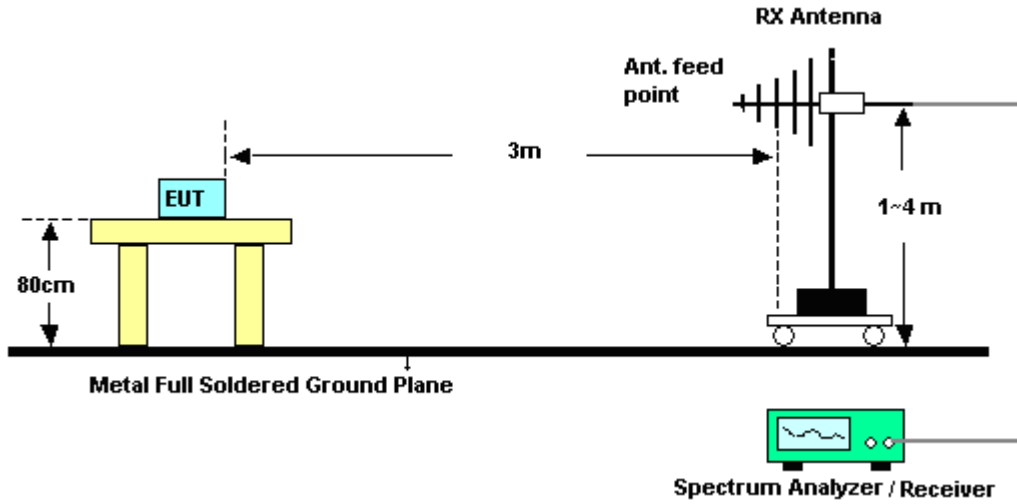

For radiated emissions above 1GHz

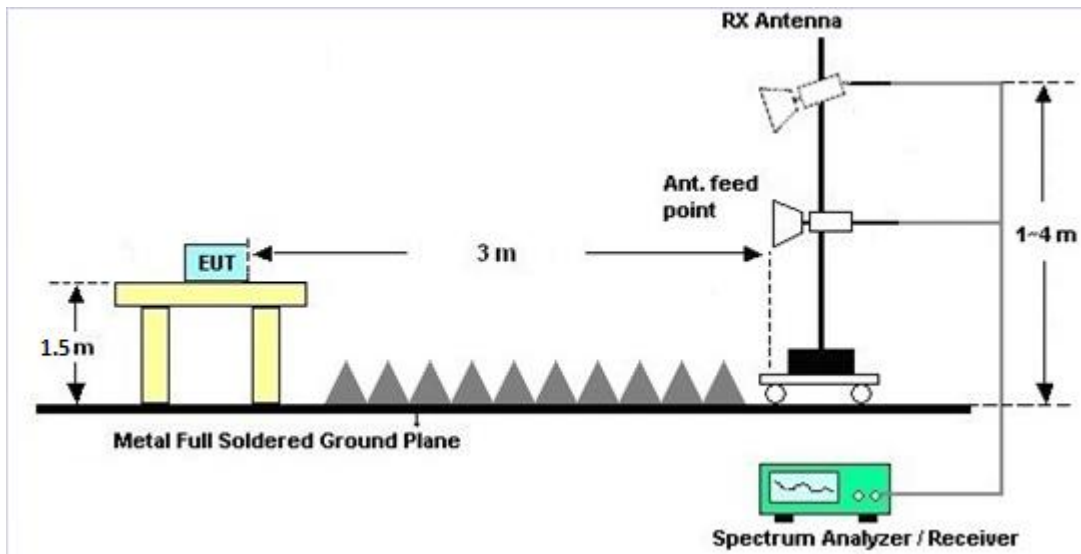

For radiated emissions above 18GHz

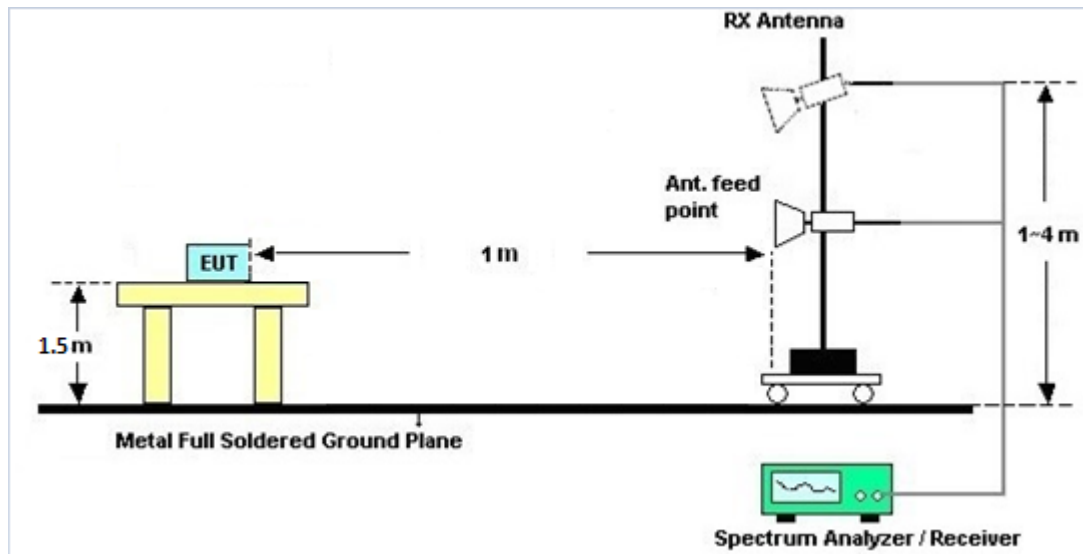

3.4.5 Test Results of Radiated Spurious Emissions (9 kHz ~ 30 MHz)

The low frequency, which started from 9 kHz to 30MHz, was pre-scanned and the result which was 20dB lower than the limit line was not reported.

There is a comparison data of both open-field test site and alternative test site - semi-Anechoic chamber according to 414788 D01 Radiated Test Site v01r01, and the result came out very similar.

3.4.6 Test Result of Radiated Spurious at Band Edges

Please refer to Appendix C and D.

3.4.7 Duty Cycle

Please refer to Appendix E.

3.4.8 Test Result of Radiated Spurious Emissions (30MHz ~ 10th Harmonic)

Please refer to Appendix C and D.



3.5 AC Conducted Emission Measurement

3.5.1 Limit of AC Conducted Emission

For equipment that is designed to be connected to the public utility (AC) power line, the radio frequency voltage that is conducted back onto the AC power line on any frequency or frequencies within the band 150 kHz to 30 MHz shall not exceed the limits in the following table.

Frequency of emission (MHz)	Conducted limit (dB μ V)	
	Quasi-peak	Average
0.15-0.5	66 to 56*	56 to 46*
0.5-5	56	46
5-30	60	50

*Decreases with the logarithm of the frequency.

3.5.2 Measuring Instruments

See list of measuring equipment of this test report.

3.5.3 Test Procedures

1. The EUT was placed 0.4 meter from the conducting wall of the shielding room was kept at least 80 centimeters from any other grounded conducting surface.
2. Connect EUT to the power mains through a line impedance stabilization network (LISN).
3. All the support units are connecting to the other LISN.
4. The LISN provides 50 ohm coupling impedance for the measuring instrument.
5. The FCC states that a 50 ohm, 50 microhenry LISN should be used.
6. Both sides of AC line were checked for maximum conducted interference.
7. The frequency range from 150 kHz to 30 MHz was searched.
8. Set the test-receiver system to Peak Detect Function and specified bandwidth with Maximum Hold Mode.

3.5.4 Test Setup

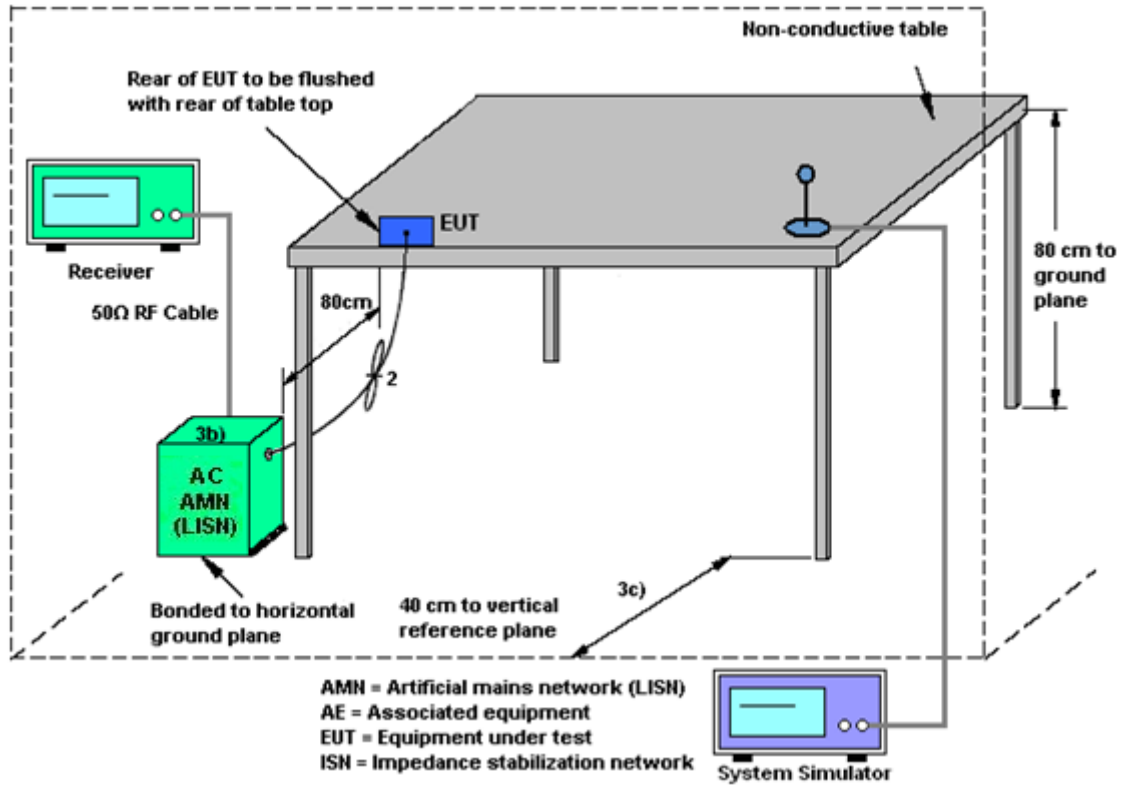

3.5.5 Test Result of AC Conducted Emission

Please refer to Appendix B.



3.6 Automatically Discontinue Transmission

3.6.1 Limit of Automatically Discontinue Transmission

The device shall automatically discontinue transmission in case of either absence of information to transmit or operational failure. These provisions are not intended to preclude the transmission of control or signaling information or the use of repetitive codes used by certain digital technologies to complete frame or burst intervals. Applicants shall include in their application for equipment authorization to describe how this requirement is met.

3.6.2 Measuring Instruments

See list of measuring equipment of this test report.

3.6.3 Test Result of Automatically Discontinue Transmission

EUT is verified this characteristic during the function check of normal sample associated with an access point:

- A. Information start: make EUT supply information to the access point.
- B. Information stop: stop supplying information to the access point.

While the EUT is not transmitting any information, the EUT can automatically discontinue transmission and become standby mode for power saving.

- C. Information start: make EUT supply information to the access point again.

The EUT can detect the controlling signal of ACK message transmitting from remote device and verify whether it shall resend or discontinue transmission.

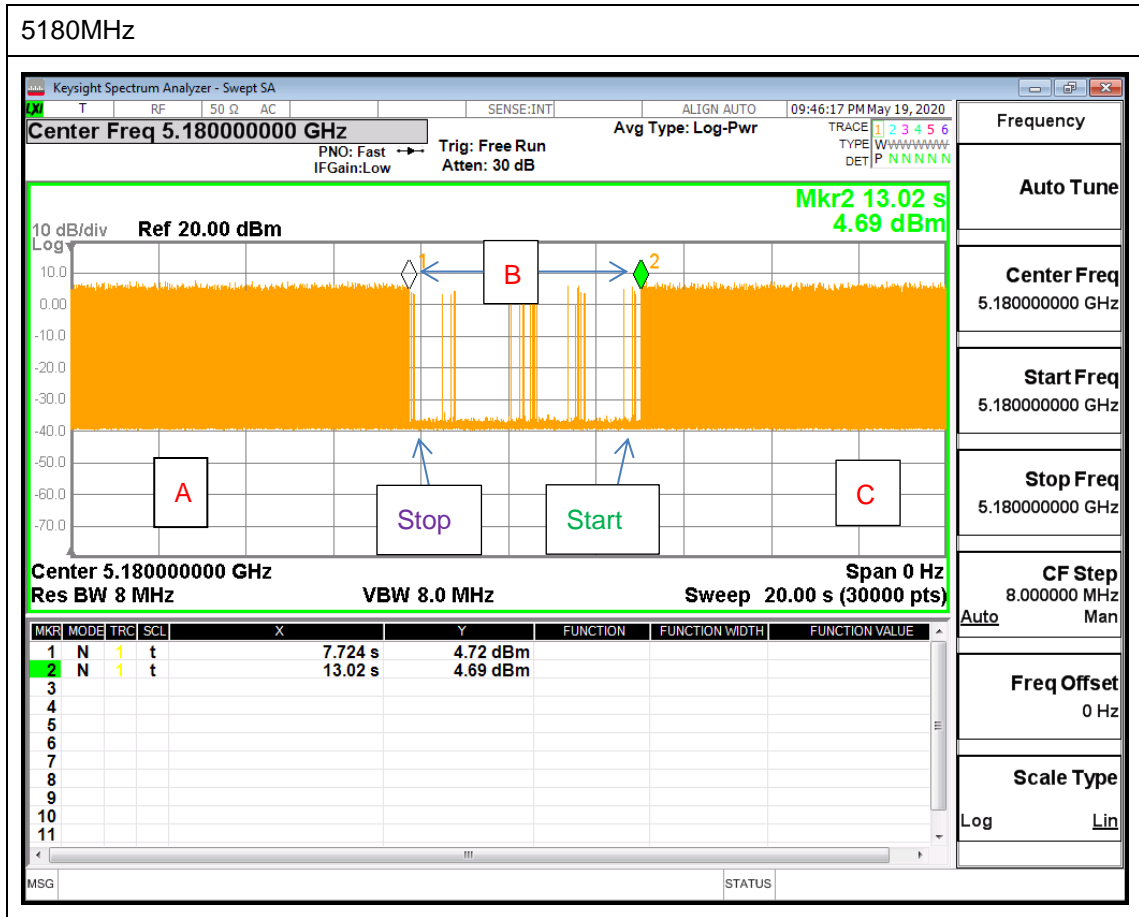

Note : The control / signalling information during the period B is precluded.



3.7 Antenna Requirements

3.7.1 Standard Applicable

If transmitting antenna directional gain is greater than 6 dBi, both the peak transmit power and the peak power spectral density shall be reduced by the amount in dB that the directional gain of the antenna exceeds 6 dBi.

3.7.2 Antenna Anti-Replacement Construction

An embedded-in antenna design is used.

3.7.3 Antenna Gain

<CDD Modes >

FCC KDB 662911 D01 Multiple Transmitter Output v02r01

For CDD transmissions, directional gain is calculated as

Directional gain = GANT + Array Gain, where Array Gain is as follows.

For power spectral density (PSD) measurements on all devices,

Array Gain = 10 log(NANT/NSS=1) dB.

For power measurements on IEEE 802.11 devices,

Array Gain = 0 dB (i.e., no array gain) for NANT ≤ 4.

Directional gain may be calculated by using the formulas applicable to equal gain antennas with GANT set equal to the gain of the antenna having the highest gain;

The EUT supports CDD mode.

For power, the directional gain GANT is set equal to the antenna having the highest gain, i.e., F)2)f)i).

For PSD, the directional gain calculation is following F)2)f)ii) of KDB 662911 D01 v02r01.

The power and PSD limit should be modified if the directional gain of EUT is over 6 dBi,

The directional gain "DG" is calculated as following table.

<CDD Modes>						
			DG	DG	Power	PSD
	Ant. 4	Ant. 3	for	for	Limit	Limit
	(dBi)	(dBi)	Power	PSD	Reduction	Reduction
	(dBi)	(dBi)	(dBi)	(dBi)	(dB)	(dB)
Band I	-2.30	-3.40	-2.30	0.18	0.00	0.00
Band II	-2.30	-3.40	-2.30	0.18	0.00	0.00
Band III	-1.90	-5.80	-1.90	-0.62	0.00	0.00

Power limit reduction = Composite gain – 6dBi, (min = 0)

PSD limit reduction = Composite gain + PSD Array gain – 6dBi, (min = 0)



4 List of Measuring Equipment

Instrument	Manufacturer	Model No.	Serial No.	Characteristics	Calibration Date	Test Date	Due Date	Remark
Loop Antenna	Rohde & Schwarz	HFH2-Z2	100488	9 kHz~30 MHz	Dec. 26, 2019	May 06, 2020~ May 20, 2020	Dec. 25, 2020	Radiation (03CH16-HY)
Bilog Antenna	TESEQ	CBL6111D&0 0802N1D01N- 06	47020&06	30MHz to 1GHz	Oct. 12, 2019	May 06, 2020~ May 20, 2020	Oct. 11, 2020	Radiation (03CH16-HY)
Horn Antenna	SCHWARZBE CK	BBHA 9120 D	9120D-152 2	1G~18GHz	Sep. 19, 2019	May 06, 2020~ May 20, 2020	Sep. 18, 2020	Radiation (03CH16-HY)
SHF-EHF Horn Antenna	SCHWARZBE CK	BBHA 9170	BBHA9170 980	18GHz~40GHz	Jan. 10, 2020	May 06, 2020~ May 20, 2020	Jan. 09, 2021	Radiation (03CH16-HY)
Amplifier	SONOMA	310N	371607	9kHz~1G	Oct. 01, 2019	May 06, 2020~ May 20, 2020	Sep. 30, 2020	Radiation (03CH16-HY)
Preamplifier	Jet-Power	JPA0118-55-3 03	171000180 0055006	1GHz~18GHz	Mar. 31, 2020	May 06, 2020~ May 20, 2020	Mar. 30, 2021	Radiation (03CH16-HY)
Preamplifier	EMEC	EMC184045B	980192	18GHz ~40GHz	Jul. 10, 2019	May 06, 2020~ May 20, 2020	Jul. 09, 2020	Radiation (03CH16-HY)
Preamplifier	Keysight	83017A	MY532702 64	1GHz~26.5GHz	Dec. 11, 2019	May 06, 2020~ May 20, 2020	Dec. 10, 2020	Radiation (03CH16-HY)
EMI Test Receiver	Keysight	N9038A (MXE)	MY572901 11	3Hz~26.5GHz	Dec. 05, 2019	May 06, 2020~ May 20, 2020	Dec. 04, 2020	Radiation (03CH16-HY)
RF Cable	HUBER + SUHNER	SUCOFLEX 104	MY11680/ 4PE	NA	Aug. 30, 2019	May 06, 2020~ May 20, 2020	Aug. 29, 2020	Radiation (03CH16-HY)
RF Cable	HUBER + SUHNER	SUCOFLEX 104	MY11688/ 4PE	NA	Aug. 30, 2019	May 06, 2020~ May 20, 2020	Aug. 29, 2020	Radiation (03CH16-HY)
RF Cable	HUBER + SUHNER	SUCOFLEX 102	EC-A5-300 -5757	NA	Aug. 30, 2019	May 06, 2020~ May 20, 2020	Aug. 29, 2020	Radiation (03CH16-HY)
Hygrometer	TECPEL	DTM-303B	TP161243	N/A	Jun. 17, 2019	May 06, 2020~ May 20, 2020	Jun. 16, 2020	Radiation (03CH16-HY)
Controller	EMEC	EM 1000	N/A	Control Turn table & Ant Mast	N/A	May 06, 2020~ May 20, 2020	N/A	Radiation (03CH16-HY)
Antenna Mast	ChainTek	MBS-520-1	N/A	1~4m	N/A	May 06, 2020~ May 20, 2020	N/A	Radiation (03CH16-HY)
Software	Audix	E3 6.2009-8-24	RK-001136	N/A	N/A	May 06, 2020~ May 20, 2020	N/A	Radiation (03CH16-HY)



Instrument	Manufacturer	Model No.	Serial No.	Characteristics	Calibration Date	Test Date	Due Date	Remark
AC Power Source	ChainTek	APC-1000W	N/A	N/A	N/A	Jun. 24,,2020	N/A	Conduction (CO05-HY)
EMI Test Receiver	Rohde & Schwarz	ESR3	102388	9kHz~3.6GHz	Nov. 15, 2019	Jun. 24,,2020	Nov. 14, 2020	Conduction (CO05-HY)
Hygrometer	Testo	608-H1	34913912	N/A	Nov. 07, 2019	Jun. 24,,2020	Nov. 06, 2020	Conduction (CO05-HY)
LISN	Rohde & Schwarz	ENV216	100080	9kHz~30MHz	Nov. 20, 2019	Jun. 24,,2020	Nov. 19, 2020	Conduction (CO05-HY)
LISN	Rohde & Schwarz	ENV216	100081	9kHz~30MHz	Nov. 15, 2019	Jun. 24,,2020	Nov. 14, 2020	Conduction (CO05-HY)
Software	Rohde & Schwarz	EMC32 V10.30	N/A	N/A	N/A	Jun. 24,,2020	N/A	Conduction (CO05-HY)
LF Cable	HUBER + SUHNER	RG-214/U	LF01	N/A	Jan. 02, 2020	Jun. 24,,2020	Jan. 01, 2021	Conduction (CO05-HY)
Pulse Limiter	Rohde & Schwarz	ESH3-Z2	100851	N/A	Jan. 02, 2020	Jun. 24,,2020	Jan. 01, 2021	Conduction (CO05-HY)
Power Sensor	DARE	RPR3006W	16I00054S NO10	10MHz~6GHz	Dec. 23, 2019	May 07, 2020~ Jul. 03, 2020	Dec. 22, 2020	Conducted (TH05-HY)
Spectrum Analyzer	Rohde & Schwarz	FSP40	100055	9kHz-40GHz	Aug. 14, 2019	May 07, 2020~ Jul. 03, 2020	Aug. 13, 2020	Conducted (TH05-HY)
Switch Box & RF Cable	Burgeon	ETF-058	EC130048 4	N/A	Aug. 22, 2019	May 07, 2020~ Jul. 03, 2020	Aug. 21, 2020	Conducted (TH05-HY)
Hygrometer	Testo	HTC-1	2	N/A	Mar. 02, 2020	May 07, 2020~ Jul. 03, 2020	Mar. 01, 2021	Conducted (TH05-HY)



5 Uncertainty of Evaluation

Uncertainty of Conducted Emission Measurement (150kHz ~ 30MHz)

Measuring Uncertainty for a Level of Confidence of 95% ($U = 2Uc(y)$)	2.3
---	-----

Uncertainty of Radiated Emission Measurement (30 MHz ~ 1000 MHz)

Measuring Uncertainty for a Level of Confidence of 95% ($U = 2Uc(y)$)	4.9
---	-----

Uncertainty of Radiated Emission Measurement (1000 MHz ~ 18000 MHz)

Measuring Uncertainty for a Level of Confidence of 95% ($U = 2Uc(y)$)	6.7
---	-----

Uncertainty of Radiated Emission Measurement (18000 MHz ~ 40000 MHz)

Measuring Uncertainty for a Level of Confidence of 95% ($U = 2Uc(y)$)	3.9
---	-----

Appendix A. Test Result of Conducted Test Items

Test Engineer:	Hank Hsu/Kathy Chen	Temperature:	21~25	°C
Test Date:	2020/5/7~2020/7/3	Relative Humidity:	51~54	%

TEST RESULTS DATA
26dB and 99% OBW

Band I MIMO													
Mod.	Data Rate	NTX	CH.	Freq. (MHz)	99% Bandwidth (MHz)		26 dB Bandwidth (MHz)		IC 99% Bandwidth Power Limit (dBm)		IC 99% Bandwidth EIRP Limit (dBm)		Note
					Ant 4	Ant 3	Ant 4	Ant 3	Ant 4	Ant 3	Ant 4	Ant 3	
11a	6Mbps	2	36	5180	16.75	16.75	25.75	25.40	-	-	22.24	22.24	
11a	6Mbps	2	44	5220	16.90	16.75	25.55	25.45	-	-	22.24	22.24	
11a	6Mbps	2	48	5240	16.75	16.70	25.20	25.20	-	-	22.23	22.23	
HT20	MCS0	2	36	5180	17.95	17.95	26.25	26.10	-	-	22.54	22.54	
HT20	MCS0	2	44	5220	20.40	18.30	26.60	25.85	-	-	22.62	22.62	
HT20	MCS0	2	48	5240	20.75	18.35	26.10	26.05	-	-	22.64	22.64	
HT40	MCS0	2	38	5190	36.60	36.60	42.12	42.30	-	-	23.01	23.01	
HT40	MCS0	2	46	5230	38.60	36.90	74.16	59.49	-	-	23.01	23.01	
VHT80	MCS0	2	42	5210	76.68	76.56	83.84	83.84	-	-	23.01	23.01	

TEST RESULTS DATA
Average Power Table

FCC Band I single antenna												
Mod.	Data Rate	NTX	CH.	Freq. (MHz)	Average Conducted Power (dBm)			FCC Conducted Power Limit (dBm)		DG (dBi)		Pass/Fail
					Ant 4	Ant 3	SUM	Ant 4	Ant 3	Ant 4	Ant 3	
11a	6Mbps	1	36	5180	17.30	18.10		24.00	24.00	-2.30	-3.40	Pass
11a	6Mbps	1	44	5220	17.30	17.20		24.00	24.00	-2.30	-3.40	Pass
11a	6Mbps	1	48	5240	17.40	17.00		24.00	24.00	-2.30	-3.40	Pass
HT20	MCS0	1	36	5180	17.30	18.10		24.00	24.00	-2.30	-3.40	Pass
HT20	MCS0	1	44	5220	17.30	17.20		24.00	24.00	-2.30	-3.40	Pass
HT20	MCS0	1	48	5240	17.50	17.10		24.00	24.00	-2.30	-3.40	Pass
HT40	MCS0	1	38	5190	12.00	12.70		24.00	24.00	-2.30	-3.40	Pass
HT40	MCS0	1	46	5230	20.30	19.90		24.00	24.00	-2.30	-3.40	Pass
VHT20	MCS0	1	36	5180	17.20	18.00		24.00	24.00	-2.30	-3.40	Pass
VHT20	MCS0	1	44	5220	17.20	17.10		24.00	24.00	-2.30	-3.40	Pass
VHT20	MCS0	1	48	5240	17.40	17.00		24.00	24.00	-2.30	-3.40	Pass
VHT40	MCS0	1	38	5190	11.90	12.60		24.00	24.00	-2.30	-3.40	Pass
VHT40	MCS0	1	46	5230	20.20	19.80		24.00	24.00	-2.30	-3.40	Pass
VHT80	MCS0	1	42	5210	12.30	12.10		24.00	24.00	-2.30	-3.40	Pass

FCC Band I MIMO												
Mod.	Data Rate	NTX	CH.	Freq. (MHz)	Average Conducted Power (dBm)			FCC Conducted Power Limit (dBm)		DG (dBi)		Pass/Fail
					Ant 4	Ant 3	SUM	Ant 4	Ant 3	Ant 4	Ant 3	
11a	6Mbps	2	36	5180	17.30	18.10	20.73	24.00		-2.30		Pass
11a	6Mbps	2	44	5220	17.30	17.20	20.26	24.00		-2.30		Pass
11a	6Mbps	2	48	5240	17.40	17.00	20.21	24.00		-2.30		Pass
HT20	MCS0	2	36	5180	17.30	18.10	20.73	24.00		-2.30		Pass
HT20	MCS0	2	44	5220	17.30	17.20	20.26	24.00		-2.30		Pass
HT20	MCS0	2	48	5240	17.50	17.10	20.31	24.00		-2.30		Pass
HT40	MCS0	2	38	5190	12.00	12.70	15.37	24.00		-2.30		Pass
HT40	MCS0	2	46	5230	20.30	19.90	23.11	24.00		-2.30		Pass
VHT20	MCS0	2	36	5180	17.20	18.00	20.63	24.00		-2.30		Pass
VHT20	MCS0	2	44	5220	17.20	17.10	20.16	24.00		-2.30		Pass
VHT20	MCS0	2	48	5240	17.40	17.00	20.21	24.00		-2.30		Pass
VHT40	MCS0	2	38	5190	11.90	12.60	15.27	24.00		-2.30		Pass
VHT40	MCS0	2	46	5230	20.20	19.80	23.01	24.00		-2.30		Pass
VHT80	MCS0	2	42	5210	12.30	12.10	15.21	24.00		-2.30		Pass

TEST RESULTS DATA
Power Spectral Density

FCC Band I MIMO												
Mod.	Data Rate	NTX	CH.	Freq. (MHz)	Average Power Density (dBm/MHz)			Average PSD Limit (dBm/MHz)		DG (dBi)		Pass /Fail
					Ant 4	Ant 3	SUM	Ant 4	Ant 3	Ant 4	Ant 3	
11a	6Mbps	2	36	5180			9.96	11.00	0.18		Pass	
11a	6Mbps	2	44	5220			9.50	11.00	0.18		Pass	
11a	6Mbps	2	48	5240			9.38	11.00	0.18		Pass	
HT20	MCS0	2	36	5180			10.10	11.00	0.18		Pass	
HT20	MCS0	2	44	5220			10.46	11.00	0.18		Pass	
HT20	MCS0	2	48	5240			9.84	11.00	0.18		Pass	
HT40	MCS0	2	38	5190			1.10	11.00	0.18		Pass	
HT40	MCS0	2	46	5230			9.04	11.00	0.18		Pass	
VHT80	MCS0	2	42	5210			-1.20	11.00	0.18		Pass	

TEST RESULTS DATA
26dB and 99% OBW

Band II MIMO															
Mod.	Data Rate	NTX	CH.	Freq. (MHz)	99% Bandwidth (MHz)		26 dB Bandwidth (MHz)		IC 99% Bandwidth Power Limit (dBm)		IC 99% Bandwidth EIRP Limit (dBm)		FCC 26dB Bandwidth Power Limit (dBm)		Note
					Ant 4	Ant 3	Ant 4	Ant 3	Ant 4	Ant 3	Ant 4	Ant 3	Ant 4	Ant 3	
11a	6Mbps	2	52	5260	16.75	16.70	24.90	24.95	23.23		29.23		23.98		
11a	6Mbps	2	60	5300	16.70	16.65	25.05	25.25	23.21		29.21		23.98		
11a	6Mbps	2	64	5320	16.80	16.70	24.95	24.95	23.23		29.23		23.98		
HT20	MCS0	2	52	5260	19.65	18.20	27.15	26.10	23.60		29.60		23.98		
HT20	MCS0	2	60	5300	18.55	18.10	26.05	25.20	23.58		29.58		23.98		
HT20	MCS0	2	64	5320	18.30	17.95	27.00	25.75	23.54		29.54		23.98		
HT40	MCS0	2	54	5270	37.50	36.90	68.40	62.55	23.98		30.00		23.98		
HT40	MCS0	2	62	5310	36.60	36.60	42.03	42.12	23.98		30.00		23.98		
VHT80	MCS0	2	58	5290	76.68	76.56	84.48	84.32	23.98		30.00		23.98		

TEST RESULTS DATA
Average Power Table

FCC Band II single antenna													
Mod.	Data Rate	NTX	CH.	Freq. (MHz)	Average Conducted Power (dBm)			FCC Conducted Power Limit (dBm)		DG (dBi)		EIRP Power Limit (dBm)	Pass/Fail
					Ant 4	Ant 3	SUM	Ant 4	Ant 3	Ant 4	Ant 3		
11a	6Mbps	1	52	5260	17.00	16.70		23.98	23.98	-2.30	-3.40	30	Pass
11a	6Mbps	1	60	5300	17.40	16.50		23.98	23.98	-2.30	-3.40	30	Pass
11a	6Mbps	1	64	5320	17.40	16.70		23.98	23.98	-2.30	-3.40	30	Pass
HT20	MCS0	1	52	5260	18.00	17.80		23.98	23.98	-2.30	-3.40	30	Pass
HT20	MCS0	1	60	5300	17.90	17.00		23.98	23.98	-2.30	-3.40	30	Pass
HT20	MCS0	1	64	5320	18.00	17.20		23.98	23.98	-2.30	-3.40	30	Pass
HT40	MCS0	1	54	5270	20.30	19.90		23.98	23.98	-2.30	-3.40	30	Pass
HT40	MCS0	1	62	5310	13.50	12.50		23.98	23.98	-2.30	-3.40	30	Pass
VHT20	MCS0	1	52	5260	17.90	17.70		23.98	23.98	-2.30	-3.40	30	Pass
VHT20	MCS0	1	60	5300	17.80	16.90		23.98	23.98	-2.30	-3.40	30	Pass
VHT20	MCS0	1	64	5320	17.90	17.10		23.98	23.98	-2.30	-3.40	30	Pass
VHT40	MCS0	1	54	5270	20.20	19.80		23.98	23.98	-2.30	-3.40	30	Pass
VHT40	MCS0	1	62	5310	13.40	12.40		23.98	23.98	-2.30	-3.40	30	Pass
VHT80	MCS0	1	58	5290	12.00	11.10		23.98	23.98	-2.30	-3.40	30	Pass

FCC Band II MIMO													
Mod.	Data Rate	NTX	CH.	Freq. (MHz)	Average Conducted Power (dBm)			FCC Conducted Power Limit (dBm)		DG (dBi)		EIRP Power Limit (dBm)	Pass/Fail
					Ant 4	Ant 3	SUM	Ant 4	Ant 3	Ant 4	Ant 3		
11a	6Mbps	2	52	5260	17.00	16.70	19.86	23.98		-2.30		30	Pass
11a	6Mbps	2	60	5300	17.40	16.50	19.98	23.98		-2.30		30	Pass
11a	6Mbps	2	64	5320	17.40	16.70	20.07	23.98		-2.30		30	Pass
HT20	MCS0	2	52	5260	18.00	17.80	20.91	23.98		-2.30		30	Pass
HT20	MCS0	2	60	5300	17.90	17.00	20.48	23.98		-2.30		30	Pass
HT20	MCS0	2	64	5320	18.00	17.20	20.63	23.98		-2.30		30	Pass
HT40	MCS0	2	54	5270	20.30	19.90	23.11	23.98		-2.30		30	Pass
HT40	MCS0	2	62	5310	13.50	12.50	16.04	23.98		-2.30		30	Pass
VHT20	MCS0	2	52	5260	17.90	17.70	20.81	23.98		-2.30		30	Pass
VHT20	MCS0	2	60	5300	17.80	16.90	20.38	23.98		-2.30		30	Pass
VHT20	MCS0	2	64	5320	17.90	17.10	20.53	23.98		-2.30		30	Pass
VHT40	MCS0	2	54	5270	20.20	19.80	23.01	23.98		-2.30		30	Pass
VHT40	MCS0	2	62	5310	13.40	12.40	15.94	23.98		-2.30		30	Pass
VHT80	MCS0	2	58	5290	12.00	11.10	14.58	23.98		-2.30		30	Pass

TEST RESULTS DATA
Power Spectral Density

Band II MIMO												
Mod.	Data Rate	NTX	CH.	Freq. (MHz)	Average Power Density (dBm/MHz)			Average PSD Limit (dBm/MHz)		DG (dBi)		Pass /Fail
					Ant 4	Ant 3	SUM	Ant 4	Ant 3	Ant 4	Ant 3	
11a	6Mbps	2	52	5260			8.92	11.00	0.18		Pass	
11a	6Mbps	2	60	5300			9.36	11.00	0.18		Pass	
11a	6Mbps	2	64	5320			9.22	11.00	0.18		Pass	
HT20	MCS0	2	52	5260			10.12	11.00	0.18		Pass	
HT20	MCS0	2	60	5300			9.94	11.00	0.18		Pass	
HT20	MCS0	2	64	5320			9.71	11.00	0.18		Pass	
HT40	MCS0	2	54	5270			9.16	11.00	0.18		Pass	
HT40	MCS0	2	62	5310			1.60	11.00	0.18		Pass	
VHT80	MCS0	2	58	5290			-1.65	11.00	0.18		Pass	

TEST RESULTS DATA
26dB and 99% OBW

Band III MIMO																
Mod.	Data Rate	NTX	CH.	Freq. (MHz)	99% Bandwidth In U-NII 2C (MHz)		26 dB Bandwidth In U-NII 2C (MHz)		IC 99% Bandwidth Power Limit (dBm)		IC 99% Bandwidth EIRP Limit (dBm)		FCC 26dB Bandwidth Power Limit (dBm)		6 dB Bandwidth for Straddle Channel (MHz)	
					Ant 4	Ant 3	Ant 4	Ant 3	Ant 4	Ant 3	Ant 4	Ant 3	Ant 4	Ant 3	Ant 4	Ant 3
11a	6Mbps	2	100	5500	17.20	17.85	25.15	25.20	23.36	23.36	29.36	29.36	23.98	23.98	----	----
11a	6Mbps	2	116	5580	17.55	18.50	25.35	24.70	23.44	23.44	29.44	29.44	23.98	23.98	----	----
11a	6Mbps	2	140	5700	16.90	16.75	25.65	24.75	23.24	23.24	29.24	29.24	23.98	23.98	----	----
HT20	MCS0	2	100	5500	18.10	18.15	26.45	25.90	23.58	23.58	29.58	29.58	23.98	23.98	----	----
HT20	MCS0	2	116	5580	18.50	19.25	26.10	25.55	23.67	23.67	29.67	29.67	23.98	23.98	----	----
HT20	MCS0	2	140	5700	17.95	17.90	25.95	27.10	23.53	23.53	29.53	29.53	23.98	23.98	----	----
HT40	MCS0	2	102	5510	36.50	36.50	41.85	41.76	23.98	23.98	30.00	30.00	23.98	23.98	----	----
HT40	MCS0	2	110	5550	36.80	37.30	56.88	67.05	23.98	23.98	30.00	30.00	23.98	23.98	----	----
HT40	MCS0	2	134	5670	37.00	37.10	63.72	53.19	23.98	23.98	30.00	30.00	23.98	23.98	----	----
VHT80	MCS0	2	106	5530	76.68	76.68	84.00	84.32	23.98	23.98	30.00	30.00	23.98	23.98	----	----
VHT80	MCS0	2	122	5610	77.28	77.40	157.96	158.40	23.98	23.98	30.00	30.00	23.98	23.98	----	----

Band III straddle channel MIMO																
Mod.	Data Rate	NTX	CH.	Freq. (MHz)	99% Bandwidth In U-NII 2C (MHz)		26 dB Bandwidth In U-NII 2C (MHz)		IC 99% Bandwidth Power Limit (dBm)		IC 99% Bandwidth EIRP Limit (dBm)		FCC 26dB Bandwidth Power Limit (dBm)		6 dB Bandwidth for Straddle Channel (MHz)	
					Ant 4	Ant 3	Ant 4	Ant 3	Ant 4	Ant 3	Ant 4	Ant 3	Ant 4	Ant 3	Ant 4	Ant 3
11a	6Mbps	2	144	5720	13.90	13.60	17.35	17.35	22.34	22.34	28.34	28.34	23.39	23.39	2.85	2.55
HT20	MCS0	2	144	5720	14.25	14.15	18.20	18.00	22.51	22.51	28.51	28.51	23.55	23.55	2.75	2.55
HT40	MCS0	2	142	5710	33.60	33.50	44.79	36.33	23.98	23.98	30.00	30.00	23.98	23.98	2.55	2.55
VHT80	MCS0	2	138	5690	73.76	73.76	115.30	115.08	23.98	23.98	30.00	30.00	23.98	23.98	2.6	2.6

TEST RESULTS DATA
Average Power Table

FCC Band III single antenna													
Mod.	Data Rate	NTX	CH.	Freq. (MHz)	Average Conducted Power (dBm)			FCC Conducted Power Limit (dBm)		DG (dBi)		EIRP Power Limit (dBm)	Pass/Fail
					Ant 4	Ant 3	SUM	Ant 4	Ant 3	Ant 4	Ant 3		
11a	6Mbps	1	100	5500	17.20	17.40		23.98	23.98	-1.90	-5.80	30	Pass
11a	6Mbps	1	116	5580	16.70	17.60		23.98	23.98	-1.90	-5.80	30	Pass
11a	6Mbps	1	140	5700	17.10	17.80		23.98	23.98	-1.90	-5.80	30	Pass
HT20	MCS0	1	100	5500	17.40	17.50		23.98	23.98	-1.90	-5.80	30	Pass
HT20	MCS0	1	116	5580	16.90	17.80		23.98	23.98	-1.90	-5.80	30	Pass
HT20	MCS0	1	140	5700	17.00	17.90		23.98	23.98	-1.90	-5.80	30	Pass
HT40	MCS0	1	102	5510	15.70	15.80		23.98	23.98	-1.90	-5.80	30	Pass
HT40	MCS0	1	110	5550	19.80	20.90		23.98	23.98	-1.90	-5.80	30	Pass
HT40	MCS0	1	134	5670	20.00	20.60		23.98	23.98	-1.90	-5.80	30	Pass
VHT20	MCS0	1	100	5500	17.30	17.40		23.98	23.98	-1.90	-5.80	30	Pass
VHT20	MCS0	1	116	5580	16.80	17.70		23.98	23.98	-1.90	-5.80	30	Pass
VHT20	MCS0	1	140	5700	16.90	17.80		23.98	23.98	-1.90	-5.80	30	Pass
VHT40	MCS0	1	102	5510	15.60	15.70		23.98	23.98	-1.90	-5.80	30	Pass
VHT40	MCS0	1	110	5550	19.70	20.80		23.98	23.98	-1.90	-5.80	30	Pass
VHT40	MCS0	1	134	5670	19.90	20.50		23.98	23.98	-1.90	-5.80	30	Pass
VHT80	MCS0	1	106	5530	12.80	12.90		23.98	23.98	-1.90	-5.80	30	Pass
VHT80	MCS0	1	122	5610	19.90	20.80		23.98	23.98	-1.90	-5.80	30	Pass

FCC Band III MIMO													
Mod.	Data Rate	NTX	CH.	Freq. (MHz)	Average Conducted Power (dBm)			FCC Conducted Power Limit (dBm)		DG (dBi)		EIRP Power Limit (dBm)	Pass/Fail
					Ant 4	Ant 3	SUM	Ant 4	Ant 3	Ant 4	Ant 3		
11a	6Mbps	2	100	5500	17.20	17.40	20.31	23.98		-1.90		30	Pass
11a	6Mbps	2	116	5580	16.70	17.60	20.18	23.98		-1.90		30	Pass
11a	6Mbps	2	140	5700	17.10	17.80	20.47	23.98		-1.90		30	Pass
HT20	MCS0	2	100	5500	17.40	17.50	20.46	23.98		-1.90		30	Pass
HT20	MCS0	2	116	5580	16.90	17.80	20.38	23.98		-1.90		30	Pass
HT20	MCS0	2	140	5700	17.00	17.90	20.48	23.98		-1.90		30	Pass
HT40	MCS0	2	102	5510	15.70	15.80	18.76	23.98		-1.90		30	Pass
HT40	MCS0	2	110	5550	19.80	20.90	23.40	23.98		-1.90		30	Pass
HT40	MCS0	2	134	5670	20.00	20.60	23.32	23.98		-1.90		30	Pass
VHT20	MCS0	2	100	5500	17.30	17.40	20.36	23.98		-1.90		30	Pass
VHT20	MCS0	2	116	5580	16.80	17.70	20.28	23.98		-1.90		30	Pass
VHT20	MCS0	2	140	5700	16.90	17.80	20.38	23.98		-1.90		30	Pass
VHT40	MCS0	2	102	5510	15.60	15.70	18.66	23.98		-1.90		30	Pass
VHT40	MCS0	2	110	5550	19.70	20.80	23.30	23.98		-1.90		30	Pass
VHT40	MCS0	2	134	5670	19.90	20.50	23.22	23.98		-1.90		30	Pass
VHT80	MCS0	2	106	5530	12.80	12.90	15.86	23.98		-1.90		30	Pass
VHT80	MCS0	2	122	5610	19.90	20.80	23.38	23.98		-1.90		30	Pass

FCC Band III straddle channel single antenna													
Mod.	Data Rate	NTX	CH.	Freq. (MHz)	Average Conducted Power (dBm)			FCC Conducted Power Limit (dBm)		DG (dBi)		EIRP Power Limit (dBm)	Pass/Fail
					Ant 4	Ant 3	SUM	Ant 4	Ant 3	Ant 4	Ant 3		
11a	6Mbps	1	144	5720	17.10	17.80		23.98	23.98	-1.90	-5.80	30	Pass
HT20	MCS0	1	144	5720	17.10	17.90		23.98	23.98	-1.90	-5.80	30	Pass
HT40	MCS0	1	142	5710	19.70	20.30		23.98	23.98	-1.90	-5.80	30	Pass
VHT20	MCS0	1	144	5720	17.00	17.80		23.98	23.98	-1.90	-5.80	30	Pass
VHT40	MCS0	1	142	5710	19.60	20.20		23.98	23.98	-1.90	-5.80	30	Pass
VHT80	MCS0	1	138	5690	19.80	20.20		23.98	23.98	-1.90	-5.80	30	Pass

FCC Band III straddle channel MIMO													
Mod.	Data Rate	NTX	CH.	Freq. (MHz)	Average Conducted Power (dBm)			FCC Conducted Power Limit (dBm)		DG (dBi)		EIRP Power Limit (dBm)	Pass/Fail
					Ant 4	Ant 3	SUM	Ant 4	Ant 3	Ant 4	Ant 3		
11a	6Mbps	2	144	5720	17.10	17.80	20.47	23.39		-1.90		30	Pass
HT20	MCS0	2	144	5720	17.10	17.90	20.53	23.55		-1.90		30	Pass
HT40	MCS0	2	142	5710	19.70	20.30	23.02	23.98		-1.90		30	Pass
VHT20	MCS0	2	144	5720	17.00	17.80	20.43	23.98		-1.90		30	Pass
VHT40	MCS0	2	142	5710	19.60	20.20	22.92	23.98		-1.90		30	Pass
VHT80	MCS0	2	138	5690	19.80	20.20	23.01	23.98		-1.90		30	Pass

TEST RESULTS DATA
Power Spectral Density

Band III MIMO												
Mod.	Data Rate	NTX	CH.	Freq. (MHz)	Average Power Density (dBm/MHz)			Average PSD Limit (dBm/MHz)		DG (dBi)		Pass /Fail
					Ant 4	Ant 3	SUM	Ant 4	Ant 3	Ant 4	Ant 3	
11a	6Mbps	2	100	5500			9.64	11.00		-0.62	Pass	
11a	6Mbps	2	116	5580			10.30	11.00		-0.62	Pass	
11a	6Mbps	2	140	5700			9.88	11.00		-0.62	Pass	
HT20	MCS0	2	100	5500			10.18	11.00		-0.62	Pass	
HT20	MCS0	2	116	5580			10.40	11.00		-0.62	Pass	
HT20	MCS0	2	140	5700			9.72	11.00		-0.62	Pass	
HT40	MCS0	2	102	5510			5.45	11.00		-0.62	Pass	
HT40	MCS0	2	110	5550			9.46	11.00		-0.62	Pass	
HT40	MCS0	2	134	5670			9.32	11.00		-0.62	Pass	
VHT80	MCS0	2	106	5530			0.02	11.00		-0.62	Pass	
VHT80	MCS0	2	122	5610			7.96	11.00		-0.62	Pass	

Band III straddle channel MIMO												
Mod.	Data Rate	NTX	CH.	Freq. (MHz)	Average Power Density (dBm/MHz)			Average PSD Limit (dBm/MHz)		DG (dBi)		Pass /Fail
					Ant 4	Ant 3	SUM	Ant 4	Ant 3	Ant 4	Ant 3	
11a	6Mbps	2	144	5720			9.67	11.00		-0.62	Pass	
HT20	MCS0	2	144	5720			9.78	11.00		-0.62	Pass	
HT40	MCS0	2	142	5710			9.12	11.00		-0.62	Pass	
VHT80	MCS0	2	138	5690			7.22	11.00		-0.62	Pass	



Appendix B. AC Conducted Emission Test Results

Test Engineer :	Tom Lee	Temperature :	23~25°C
		Relative Humidity :	42~50%

EUT Information

Test Mode : Mode 1
 Test Voltage : 120Vac/60Hz
 Phase : Line

Full Spectrum

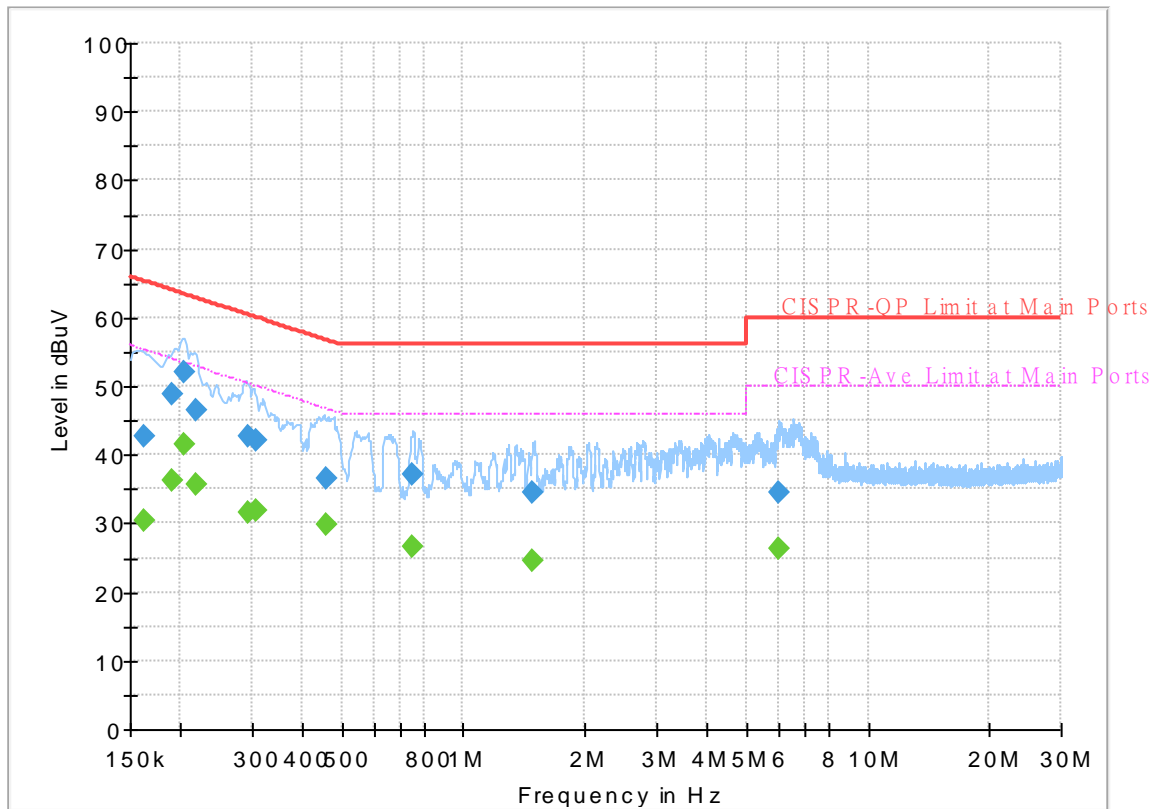

Final_Result

Frequency (MHz)	QuasiPeak (dBuV)	CAverage (dBuV)	Limit (dBuV)	Margin (dB)	Line	Filter	Corr. (dB)
0.162420	---	30.49	55.34	24.85	L1	OFF	19.6
0.162420	42.80	---	65.34	22.54	L1	OFF	19.6
0.191490	---	36.36	53.97	17.61	L1	OFF	19.6
0.191490	48.84	---	63.97	15.13	L1	OFF	19.6
0.204630	---	41.60	53.42	11.82	L1	OFF	19.6
0.204630	52.06	---	63.42	11.36	L1	OFF	19.6
0.217500	---	35.54	52.91	17.37	L1	OFF	19.6
0.217500	46.60	---	62.91	16.31	L1	OFF	19.6
0.293640	---	31.56	50.42	18.86	L1	OFF	19.6
0.293640	42.57	---	60.42	17.85	L1	OFF	19.6
0.306780	---	31.88	50.06	18.18	L1	OFF	19.6
0.306780	42.02	---	60.06	18.04	L1	OFF	19.6
0.456000	---	29.89	46.77	16.88	L1	OFF	19.6
0.456000	36.69	---	56.77	20.08	L1	OFF	19.6
0.744000	---	26.68	46.00	19.32	L1	OFF	19.6
0.744000	37.11	---	56.00	18.89	L1	OFF	19.6
1.486770	---	24.65	46.00	21.35	L1	OFF	19.6
1.486770	34.59	---	56.00	21.41	L1	OFF	19.6
6.031500	---	26.35	50.00	23.65	L1	OFF	19.9
6.031500	34.51	---	60.00	25.49	L1	OFF	19.9

EUT Information

Test Mode : Mode 1
 Test Voltage : 120Vac/60Hz
 Phase : Neutral

Full Spectrum

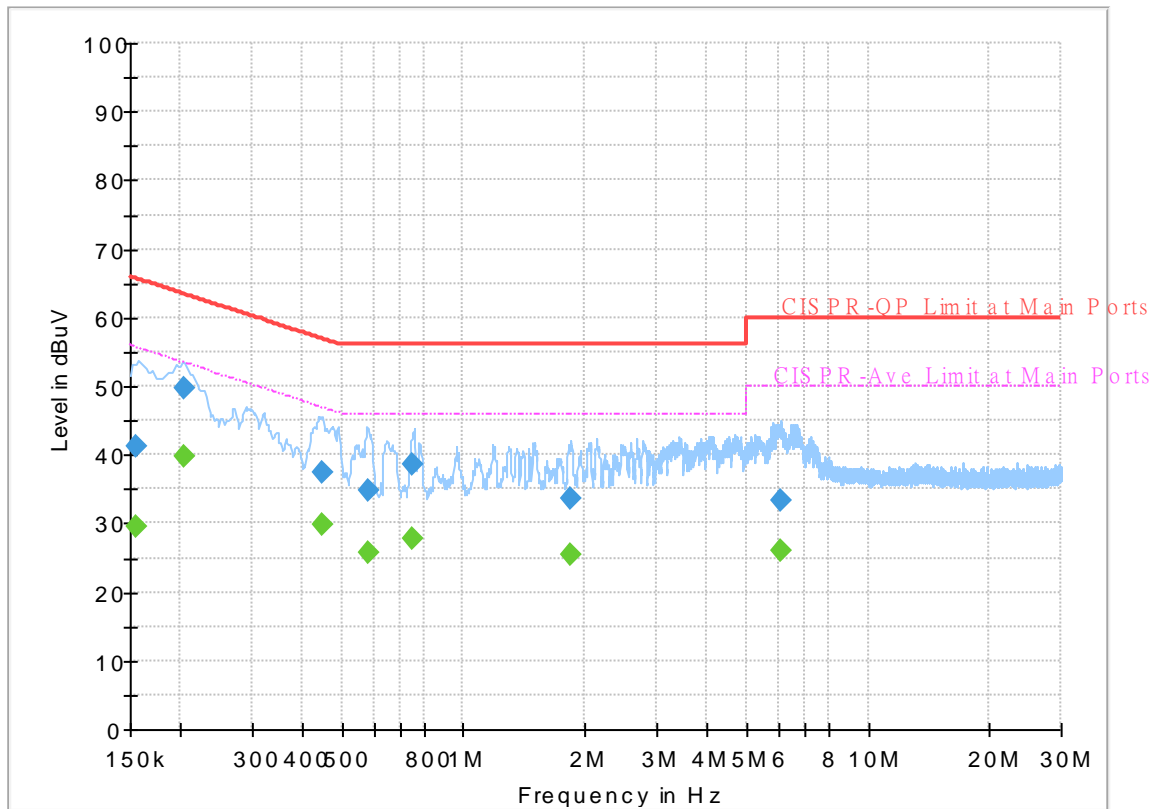

Final_Result

Frequency (MHz)	QuasiPeak (dBuV)	CAverage (dBuV)	Limit (dBuV)	Margin (dB)	Line	Filter	Corr. (dB)
0.154500	---	29.46	55.75	26.29	N	OFF	19.5
0.154500	41.29	---	65.75	24.46	N	OFF	19.5
0.205080	---	39.91	53.40	13.49	N	OFF	19.5
0.205080	49.80	---	63.40	13.60	N	OFF	19.5
0.449250	---	29.70	46.89	17.19	N	OFF	19.5
0.449250	37.41	---	56.89	19.48	N	OFF	19.5
0.579300	---	25.87	46.00	20.13	N	OFF	19.5
0.579300	34.88	---	56.00	21.12	N	OFF	19.5
0.750750	---	27.90	46.00	18.10	N	OFF	19.5
0.750750	38.57	---	56.00	17.43	N	OFF	19.5
1.837500	---	25.41	46.00	20.59	N	OFF	19.6
1.837500	33.62	---	56.00	22.38	N	OFF	19.6
6.090000	---	26.11	50.00	23.89	N	OFF	19.7
6.090000	33.30	---	60.00	26.70	N	OFF	19.7



Appendix C. Radiated Spurious Emission

Test Engineer :	Karl Hou, CR Liao, and Andy Yang	Temperature :	20~25°C
		Relative Humidity :	50~60%

Band 1 - 5150~5250MHz
WIFI 802.11a (Band Edge @ 3m)

WIFI Ant.	Note	Frequency (MHz)	Level (dBμV/m)	Over Limit (dB)	Limit Line (dBμV/m)	Read Level (dBμV)	Antenna Factor (dB/m)	Path Loss (dB)	Preamp Factor (dB)	Ant Pos (cm)	Table Pos (deg)	Peak Avg. (P/A)	Pol. (H/V)	
802.11a CH 36 5180MHz		5150	60.03	-13.97	74	44.86	31.7	12.32	28.85	100	119	P	H	
		5150	51.31	-2.69	54	36.14	31.7	12.32	28.85	100	119	A	H	
	*	5180	112.16	-	-	97.09	31.58	12.36	28.87	100	119	P	H	
	*	5180	104.8	-	-	89.73	31.58	12.36	28.87	100	119	A	H	
													H	
			5149.24	58.19	-15.81	74	43.02	31.7	12.32	28.85	100	96	P	V
			5148.2	48.08	-5.92	54	32.91	31.7	12.32	28.85	100	96	A	V
	*		5180	110.29	-	-	95.22	31.58	12.36	28.87	100	96	P	V
	*		5180	102.58	-	-	87.51	31.58	12.36	28.87	100	96	A	V
														V
802.11a CH 44 5220MHz		5144.04	54.72	-19.28	74	39.55	31.71	12.31	28.85	101	120	P	H	
		5147.94	43.06	-10.94	54	27.89	31.7	12.32	28.85	101	120	A	H	
	*	5220	115.47	-	-	100.54	31.42	12.41	28.9	101	120	P	H	
	*	5220	107.44	-	-	92.51	31.42	12.41	28.9	101	120	A	H	
			5439	53.64	-20.36	74	38.47	31.56	12.65	29.04	101	120	P	H
			5454.68	41.65	-12.35	54	26.41	31.61	12.68	29.05	101	120	A	H
			5064.22	55.42	-18.58	74	40.27	31.73	12.21	28.79	104	98	P	V
			5149.76	42.86	-11.14	54	27.69	31.7	12.32	28.85	104	98	A	V
	*		5220	112.53	-	-	97.6	31.42	12.41	28.9	104	98	P	V
	*		5220	105.59	-	-	90.66	31.42	12.41	28.9	104	98	A	V
			5446	53.51	-20.49	74	38.3	31.58	12.67	29.04	104	98	P	V
			5447.96	41.7	-12.3	54	26.49	31.59	12.67	29.05	104	98	A	V



802.11a CH 48 5240MHz		5026.78	54.32	-19.68	74	39.32	31.61	12.16	28.77	100	119	P	H
		5149.24	42.72	-11.28	54	27.55	31.7	12.32	28.85	100	119	A	H
	*	5240	115.69	-	-	100.83	31.34	12.43	28.91	100	119	P	H
	*	5240	108.05	-	-	93.19	31.34	12.43	28.91	100	119	A	H
		5418.84	53.69	-20.31	74	38.62	31.48	12.62	29.03	100	119	P	H
		5455.24	41.75	-12.25	54	26.51	31.61	12.68	29.05	100	119	A	H
		5077.74	54.19	-19.81	74	39.01	31.76	12.22	28.8	104	99	P	V
		5149.76	42.5	-11.5	54	27.33	31.7	12.32	28.85	104	99	A	V
	*	5240	113.38	-	-	98.52	31.34	12.43	28.91	104	99	P	V
	*	5240	106.18	-	-	91.32	31.34	12.43	28.91	104	99	A	V
		5421.36	52.78	-21.22	74	37.7	31.49	12.62	29.03	104	99	P	V
		5455.52	41.74	-12.26	54	26.49	31.61	12.69	29.05	104	99	A	V
Remark	1. No other spurious found. 2. All results are PASS against Peak and Average limit line.												



Band 1 5150~5250MHz
WIFI 802.11a (Harmonic @ 3m)

WIFI Ant. 4+3	Note	Frequency (MHz)	Level (dBμV/m)	Over Limit (dB)	Limit Line (dBμV/m)	Read Level (dBμV)	Antenna Factor (dB/m)	Path Loss (dB)	Preamp Factor (dB)	Ant Pos (cm)	Table Pos (deg)	Peak Avg. (P/A)	Pol. (H/V)
802.11a CH 36 5180MHz		10360	48.94	-19.26	68.2	51.03	39.64	19.17	60.9	100	0	P	H
		15540	48.41	-25.59	74	48.8	37.94	24.38	62.71	100	0	P	H
													H
													H
		10360	48.89	-19.31	68.2	50.98	39.64	19.17	60.9	100	0	P	V
		15540	49.14	-24.86	74	49.53	37.94	24.38	62.71	100	0	P	V
													V
													V
802.11a CH 44 5220MHz		10440	50.13	-18.07	68.2	51.98	39.88	19.29	61.02	188	266	P	H
		10440	39.7	-14.3	54	41.55	39.88	19.29	61.02	188	266	A	H
													H
													H
		15660	50.35	-23.65	74	50.64	37.46	24.38	62.13	100	0	P	H
		10440	49.78	-18.42	68.2	51.63	39.88	19.29	61.02	100	0	P	V
		15660	47.67	-26.33	74	47.96	37.46	24.38	62.13	100	0	P	V
													V
802.11a CH 48 5240MHz		10480	50.15	-18.05	68.2	51.91	39.96	19.35	61.07	100	0	P	H
		15720	49.09	-24.91	74	49.26	37.3	24.37	61.84	100	0	P	H
													H
													H
		10480	49.74	-18.46	68.2	51.5	39.96	19.35	61.07	100	0	P	V
		15720	47.98	-26.02	74	48.15	37.3	24.37	61.84	100	0	P	V
													V
													V
Remark	1. No other spurious found. 2. All results are PASS against Peak and Average limit line.												



Band 1 5150~5250MHz
WIFI 802.11n HT20 (Band Edge @ 3m)

WIFI Ant. 4+3	Note	Frequency (MHz)	Level (dBμV/m)	Over Limit (dB)	Limit Line (dBμV/m)	Read Level (dBμV)	Antenna Factor (dB/m)	Path Loss (dB)	Preamp Factor (dB)	Ant Pos (cm)	Table Pos (deg)	Peak Avg. (P/A)	Pol. (H/V)	
802.11n HT20 CH 36 5180MHz		5148.72	60.49	-13.51	74	45.32	31.7	12.32	28.85	246	122	P	H	
		5150	50.81	-3.19	54	35.64	31.7	12.32	28.85	246	122	A	H	
	*	5180	111.38	-	-	96.31	31.58	12.36	28.87	246	122	P	H	
	*	5180	103.47	-	-	88.4	31.58	12.36	28.87	246	122	A	H	
													H	
														H
			5146.9	57.06	-16.94	74	41.88	31.71	12.32	28.85	100	99	P	V
			5150	46.4	-7.6	54	31.23	31.7	12.32	28.85	100	99	A	V
		*	5180	109.86	-	-	94.79	31.58	12.36	28.87	100	99	P	V
		*	5180	101.84	-	-	86.77	31.58	12.36	28.87	100	99	A	V
													V	
													V	
802.11n HT20 CH 44 5220MHz		5073.32	53.83	-20.17	74	38.66	31.75	12.22	28.8	269	125	P	H	
		5148.72	43.07	-10.93	54	27.9	31.7	12.32	28.85	269	125	A	H	
		* 5220	114.35	-	-	99.42	31.42	12.41	28.9	269	125	P	H	
		* 5220	106.35	-	-	91.42	31.42	12.41	28.9	269	125	A	H	
			5420.8	52.28	-21.72	74	37.21	31.48	12.62	29.03	269	125	P	H
			5458.32	41.8	-12.2	54	26.54	31.62	12.69	29.05	269	125	A	H
			5146.9	53.39	-20.61	74	38.21	31.71	12.32	28.85	112	105	P	V
			5148.2	42.7	-11.3	54	27.53	31.7	12.32	28.85	112	105	A	V
		*	5220	113.91	-	-	98.98	31.42	12.41	28.9	112	105	P	V
		*	5220	105.7	-	-	90.77	31.42	12.41	28.9	112	105	A	V
		5426.96	53.09	-20.91	74	37.98	31.51	12.63	29.03	112	105	P	V	
		5451.04	41.72	-12.28	54	26.49	31.6	12.68	29.05	112	105	A	V	



802.11n HT20 CH 48 5240MHz		5092.82	54.53	-19.47	74	39.3	31.79	12.25	28.81	284	122	P	H
		5149.24	42.52	-11.48	54	27.35	31.7	12.32	28.85	284	122	A	H
	*	5240	114.7	-	-	99.84	31.34	12.43	28.91	284	122	P	H
	*	5240	106.67	-	-	91.81	31.34	12.43	28.91	284	122	A	H
		5436.48	53.5	-20.5	74	38.34	31.55	12.65	29.04	284	122	P	H
		5458.32	41.7	-12.3	54	26.44	31.62	12.69	29.05	284	122	A	H
		5085.28	53.72	-20.28	74	38.52	31.77	12.24	28.81	106	99	P	V
		5150	42.48	-11.52	54	27.31	31.7	12.32	28.85	106	99	A	V
	*	5240	114.79	-	-	99.93	31.34	12.43	28.91	106	99	P	V
	*	5240	106.4	-	-	91.54	31.34	12.43	28.91	106	99	A	V
		5378.8	53.31	-20.69	74	38.43	31.32	12.56	29	106	99	P	V
		5447.68	41.76	-12.24	54	26.55	31.59	12.67	29.05	106	99	A	V
Remark	1. No other spurious found. 2. All results are PASS against Peak and Average limit line.												



Band 1 5150~5250MHz
WIFI 802.11n HT20 (Harmonic @ 3m)

WIFI Ant. 4+3	Note	Frequency (MHz)	Level (dBμV/m)	Over Limit (dB)	Limit Line (dBμV/m)	Read Level (dBμV)	Antenna Factor (dB/m)	Path Loss (dB)	Preamp Factor (dB)	Ant Pos (cm)	Table Pos (deg)	Peak Avg. (P/A)	Pol. (H/V)	
802.11n HT20 CH 36 5180MHz		10360	48.84	-19.36	68.2	50.93	39.64	19.17	60.9	100	0	P	H	
		15540	48.9	-25.1	74	49.29	37.94	24.38	62.71	100	0	P	H	
													H	
													H	
			10360	49.83	-18.37	68.2	51.92	39.64	19.17	60.9	100	0	P	V
			15540	48.68	-25.32	74	49.07	37.94	24.38	62.71	100	0	P	V
														V
802.11n HT20 CH 44 5220MHz		10440	49.1	-19.1	68.2	50.95	39.88	19.29	61.02	100	0	P	H	
		15660	49.01	-24.99	74	49.3	37.46	24.38	62.13	100	0	P	H	
													H	
													H	
			10440	50.12	-18.08	68.2	51.97	39.88	19.29	61.02	100	0	P	V
			15660	48.37	-25.63	74	48.66	37.46	24.38	62.13	100	0	P	V
														V
802.11n HT20 CH 48 5240MHz		10480	49.35	-18.85	68.2	51.11	39.96	19.35	61.07	100	0	P	H	
		15720	48.41	-25.59	74	48.58	37.3	24.37	61.84	100	0	P	H	
													H	
													H	
			10480	50.89	-17.31	68.2	52.65	39.96	19.35	61.07	100	0	P	V
			15720	49.14	-24.86	74	49.31	37.3	24.37	61.84	100	0	P	V
														V
Remark	1. No other spurious found.													
	2. All results are PASS against Peak and Average limit line.													



**Band 1 5150~5250MHz
WIFI 802.11n HT40 (Band Edge @ 3m)**

WIFI Ant. 4+3	Note	Frequency (MHz)	Level (dBμV/m)	Over Limit (dB)	Limit Line (dBμV/m)	Read Level (dBμV)	Antenna Factor (dB/m)	Path Loss (dB)	Preamp Factor (dB)	Ant Pos (cm)	Table Pos (deg)	Peak Avg. (P/A)	Pol. (H/V)
802.11n HT40 CH 38 5190MHz		5149.76	60.55	-13.45	74	45.38	31.7	12.32	28.85	101	124	P	H
		5150	52.38	-1.62	54	37.21	31.7	12.32	28.85	101	124	A	H
	*	5190	105.5	-	-	90.46	31.54	12.38	28.88	101	124	P	H
	*	5190	97.74	-	-	82.7	31.54	12.38	28.88	101	124	A	H
		5437.88	53.14	-20.86	74	37.98	31.55	12.65	29.04	101	124	P	H
		5377.68	44.25	-9.75	54	29.38	31.31	12.56	29	101	124	A	H
		5147.42	57.25	-16.75	74	42.07	31.71	12.32	28.85	101	104	P	V
		5147.68	48.89	-5.11	54	33.72	31.7	12.32	28.85	101	104	A	V
	*	5190	102.42	-	-	87.38	31.54	12.38	28.88	101	104	P	V
	*	5190	95.28	-	-	80.24	31.54	12.38	28.88	101	104	A	V
		5436.76	53.09	-20.91	74	37.93	31.55	12.65	29.04	101	104	P	V
		5452.16	44.25	-9.75	54	29.02	31.6	12.68	29.05	101	104	A	V
802.11n HT40 CH 46 5230MHz		5149.5	58.61	-15.39	74	43.44	31.7	12.32	28.85	102	122	P	H
		5149.24	50.01	-3.99	54	34.84	31.7	12.32	28.85	102	122	A	H
	*	5230	114.18	-	-	99.28	31.38	12.42	28.9	102	122	P	H
	*	5230	106.48	-	-	91.58	31.38	12.42	28.9	102	122	A	H
		5434.8	53.86	-20.14	74	38.71	31.54	12.65	29.04	102	122	P	H
		5350.8	44.72	-9.28	54	29.97	31.2	12.53	28.98	102	122	A	H
		5148.98	56.18	-17.82	74	41.01	31.7	12.32	28.85	100	104	P	V
		5145.86	47.93	-6.07	54	32.75	31.71	12.32	28.85	100	104	A	V
	*	5230	111.24	-	-	96.34	31.38	12.42	28.9	100	104	P	V
	*	5230	103.71	-	-	88.81	31.38	12.42	28.9	100	104	A	V
	5359.2	54.01	-19.99	74	39.22	31.24	12.54	28.99	100	104	P	V	
	5432.28	44.54	-9.46	54	29.41	31.53	12.64	29.04	100	104	A	V	
Remark	1. No other spurious found. 2. All results are PASS against Peak and Average limit line.												



Band 1 5150~5250MHz
WIFI 802.11n HT40 (Harmonic @ 3m)

WIFI Ant. 4+3	Note	Frequency (MHz)	Level (dBμV/m)	Over Limit (dB)	Limit Line (dBμV/m)	Read Level (dBμV)	Antenna Factor (dB/m)	Path Loss (dB)	Preamp Factor (dB)	Ant Pos (cm)	Table Pos (deg)	Peak Avg. (P/A)	Pol. (H/V)
802.11n HT40 CH 38 5190MHz		10380	48.61	-19.59	68.2	50.62	39.72	19.2	60.93	100	0	P	H
		15570	47.78	-26.22	74	48.14	37.82	24.38	62.56	100	0	P	H
													H
													H
		10380	48.66	-19.54	68.2	50.67	39.72	19.2	60.93	100	0	P	V
		15570	47.16	-26.84	74	47.52	37.82	24.38	62.56	100	0	P	V
													V
													V
802.11n HT40 CH 46 5230MHz		10460	48.32	-19.88	68.2	50.12	39.92	19.32	61.04	100	0	P	H
		15690	47.37	-26.63	74	47.65	37.34	24.37	61.99	100	0	P	H
													H
													H
		10460	48.56	-19.64	68.2	50.36	39.92	19.32	61.04	100	0	P	V
		15690	46.56	-27.44	74	46.84	37.34	24.37	61.99	100	0	P	V
													V
													V
Remark	1. No other spurious found. 2. All results are PASS against Peak and Average limit line.												



Band 1 5150~5250MHz
WIFI 802.11ac VHT80 (Band Edge @ 3m)

WIFI Ant. 4+3	Note	Frequency (MHz)	Level (dBμV/m)	Over Limit (dB)	Limit Line (dBμV/m)	Read Level (dBμV)	Antenna Factor (dB/m)	Path Loss (dB)	Preamp Factor (dB)	Ant Pos (cm)	Table Pos (deg)	Peak Avg. (P/A)	Pol. (H/V)
802.11ac VHT80 CH 42 5210MHz		5140.4	59.63	-14.37	74	44.44	31.72	12.31	28.84	100	123	P	H
		5143	51.63	-2.37	54	36.45	31.71	12.31	28.84	100	123	A	H
	*	5210	101.98	-	-	87.01	31.46	12.4	28.89	100	123	P	H
	*	5210	94.51	-	-	79.54	31.46	12.4	28.89	100	123	A	H
		5424.72	53.58	-20.42	74	38.48	31.5	12.63	29.03	100	123	P	H
		5364.8	44.45	-9.55	54	29.63	31.26	12.55	28.99	100	123	A	H
		5150	59.04	-14.96	74	43.87	31.7	12.32	28.85	100	103	P	V
		5150	51.11	-2.89	54	35.94	31.7	12.32	28.85	100	103	A	V
	*	5210	100.02	-	-	85.05	31.46	12.4	28.89	100	103	P	V
	*	5210	93.24	-	-	78.27	31.46	12.4	28.89	100	103	A	V
		5393.92	53.93	-20.07	74	38.99	31.38	12.57	29.01	100	103	P	V
	5439	45	-9	54	29.83	31.56	12.65	29.04	100	103	A	V	
Remark	1. No other spurious found. 2. All results are PASS against Peak and Average limit line.												



Band 1 5150~5250MHz

WIFI 802.11ac VHT80 (Harmonic @ 3m)

WIFI Ant. 4+3	Note	Frequency (MHz)	Level (dBμV/m)	Over Limit (dB)	Limit Line (dBμV/m)	Read Level (dBμV)	Antenna Factor (dB/m)	Path Loss (dB)	Preamp Factor (dB)	Ant Pos (cm)	Table Pos (deg)	Peak Avg. (P/A)	Pol. (H/V)	
802.11ac VHT80 CH 42 5210MHz		10420	47.7	-20.5	68.2	49.59	39.84	19.26	60.99	100	0	P	H	
		15630	46.94	-27.06	74	47.27	37.58	24.37	62.28	100	0	P	H	
													H	
													H	
			10420	47.92	-20.28	68.2	49.81	39.84	19.26	60.99	100	0	P	V
			15630	46.75	-27.25	74	47.08	37.58	24.37	62.28	100	0	P	V
														V
													V	
Remark	1. No other spurious found. 2. All results are PASS against Peak and Average limit line.													



Band 2 - 5250~5350MHz
WIFI 802.11a (Band Edge @ 3m)

WIFI	Note	Frequency	Level	Over	Limit	Read	Antenna	Path	Preamp	Ant	Table	Peak	Pol.
Ant.				Limit	Line	Level	Factor	Loss	Factor	Pos	Pos	Avg.	
4+3		(MHz)	(dBμV/m)	(dB)	(dBμV/m)	(dBμV)	(dB/m)	(dB)	(dB)	(cm)	(deg)	(P/A)	(H/V)
802.11a CH 52 5260MHz		5051.68	53.48	-20.52	74	38.37	31.7	12.19	28.78	101	120	P	H
		5147.9	42.53	-11.47	54	27.36	31.7	12.32	28.85	101	120	A	H
	*	5260	116.1	-	-	101.27	31.3	12.45	28.92	101	120	P	H
	*	5260	108.34	-	-	93.51	31.3	12.45	28.92	101	120	A	H
		5351.76	54.39	-19.61	74	39.63	31.21	12.53	28.98	101	120	P	H
		5351.76	42.01	-11.99	54	27.25	31.21	12.53	28.98	101	120	A	H
		5100.98	54.02	-19.98	74	38.78	31.8	12.26	28.82	101	98	P	V
		5106.76	42.46	-11.54	54	27.23	31.79	12.26	28.82	101	98	A	V
	*	5260	113.87	-	-	99.04	31.3	12.45	28.92	101	98	P	V
	*	5260	106.59	-	-	91.76	31.3	12.45	28.92	101	98	A	V
		5382.48	53.36	-20.64	74	38.47	31.33	12.56	29	101	98	P	V
		5350.56	41.76	-12.24	54	27.01	31.2	12.53	28.98	101	98	A	V
802.11a CH 60 5300MHz		5061.54	54.16	-19.84	74	39.03	31.72	12.2	28.79	102	120	P	H
		5145.52	42.43	-11.57	54	27.25	31.71	12.32	28.85	102	120	A	H
	*	5300	115.91	-	-	101.07	31.3	12.49	28.95	102	120	P	H
	*	5300	107.94	-	-	93.1	31.3	12.49	28.95	102	120	A	H
		5353.2	54.51	-19.49	74	39.74	31.21	12.54	28.98	102	120	P	H
		5353.2	44.14	-9.86	54	29.37	31.21	12.54	28.98	102	120	A	H
		5119.68	54.26	-19.74	74	39.05	31.76	12.28	28.83	108	100	P	V
		5147.56	42.4	-11.6	54	27.23	31.7	12.32	28.85	108	100	A	V
	*	5300	113.17	-	-	98.33	31.3	12.49	28.95	108	100	P	V
	*	5300	106.02	-	-	91.18	31.3	12.49	28.95	108	100	A	V
		5455.92	53.17	-20.83	74	37.92	31.61	12.69	29.05	108	100	P	V
		5350.8	43.31	-10.69	54	28.56	31.2	12.53	28.98	108	100	A	V



802.11a CH 64 5320MHz	*	5320	115.86	-	-	101.06	31.26	12.5	28.96	100	119	P	H
	*	5320	107.85	-	-	93.05	31.26	12.5	28.96	100	119	A	H
		5353.76	59.59	-14.41	74	44.81	31.22	12.54	28.98	100	119	P	H
		5352.96	48.48	-5.52	54	33.71	31.21	12.54	28.98	100	119	A	H
													H
													H
	*	5320	113.42	-	-	98.62	31.26	12.5	28.96	107	100	P	V
	*	5320	106.26	-	-	91.46	31.26	12.5	28.96	107	100	A	V
		5350.56	58.94	-15.06	74	44.19	31.2	12.53	28.98	107	100	P	V
		5350.08	49.29	-4.71	54	34.54	31.2	12.53	28.98	107	100	A	V
													V
													V
Remark	1. No other spurious found. 2. All results are PASS against Peak and Average limit line.												



Band 2 5250~5350MHz
WIFI 802.11a (Harmonic @ 3m)

WIFI Ant. 4+3	Note	Frequency (MHz)	Level (dBμV/m)	Over Limit (dB)	Limit Line (dBμV/m)	Read Level (dBμV)	Antenna Factor (dB/m)	Path Loss (dB)	Preamp Factor (dB)	Ant Pos (cm)	Table Pos (deg)	Peak Avg. (P/A)	Pol. (H/V)
802.11a CH 52 5260MHz		10520	49.01	-19.19	68.2	50.69	40	19.42	61.1	100	0	P	H
		15780	49.12	-24.88	74	49.01	37.3	24.37	61.56	100	0	P	H
													H
													H
		10520	50.48	-17.72	68.2	52.16	40	19.42	61.1	100	0	P	V
		15780	47.58	-26.42	74	47.47	37.3	24.37	61.56	100	0	P	V
													V
													V
802.11a CH 60 5300MHz		10600	49.74	-24.26	74	51.3	40	19.54	61.1	100	0	P	H
		15900	48.5	-25.5	74	48.02	37.1	24.36	60.98	100	0	P	H
													H
													H
		10600	51.41	-22.59	74	52.97	40	19.54	61.1	317	320	P	V
		10600	40.2	-13.8	54	41.76	40	19.54	61.1	317	320	A	V
		15900	48.22	-25.78	74	47.74	37.1	24.36	60.98	100	0	P	V
													V
802.11a CH 64 5320MHz		10640	47.77	-26.23	74	49.27	40	19.6	61.1	100	0	P	H
		15960	48.2	-25.8	74	47.49	37.04	24.36	60.69	100	0	P	H
													H
													H
		10640	48.8	-25.2	74	50.3	40	19.6	61.1	100	0	P	V
		15960	47.69	-26.31	74	46.98	37.04	24.36	60.69	100	0	P	V
													V
													V
Remark	1. No other spurious found. 2. All results are PASS against Peak and Average limit line.												



Band 2 5250~5350MHz
WIFI 802.11n HT20 (Band Edge @ 3m)

WIFI Ant. 4+3	Note	Frequency (MHz)	Level (dBμV/m)	Over Limit (dB)	Limit Line (dBμV/m)	Read Level (dBμV)	Antenna Factor (dB/m)	Path Loss (dB)	Preamp Factor (dB)	Ant Pos (cm)	Table Pos (deg)	Peak Avg. (P/A)	Pol. (H/V)
802.11n HT20 CH 52 5260MHz		5077.86	54.21	-19.79	74	39.02	31.76	12.23	28.8	101	121	P	H
		5098.94	43.16	-10.84	54	27.93	31.8	12.25	28.82	101	121	A	H
	*	5260	115.31	-	-	100.48	31.3	12.45	28.92	101	121	P	H
	*	5260	107.93	-	-	93.1	31.3	12.45	28.92	101	121	A	H
		5400.96	54.05	-19.95	74	39.08	31.4	12.58	29.01	101	121	P	H
		5350.32	42.74	-11.26	54	27.99	31.2	12.53	28.98	101	121	A	H
		5110.5	54.36	-19.64	74	39.13	31.78	12.27	28.82	105	97	P	V
		5104.38	43.08	-10.92	54	27.85	31.79	12.26	28.82	105	97	A	V
	*	5260	114.75	-	-	99.92	31.3	12.45	28.92	105	97	P	V
	*	5260	107.1	-	-	92.27	31.3	12.45	28.92	105	97	A	V
		5401.44	54.02	-19.98	74	39.04	31.41	12.58	29.01	105	97	P	V
		5350.08	42.42	-11.58	54	27.67	31.2	12.53	28.98	105	97	A	V
802.11n HT20 CH 60 5300MHz		5031.96	54.03	-19.97	74	39.01	31.63	12.16	28.77	101	123	P	H
		5141.78	43.04	-10.96	54	27.85	31.72	12.31	28.84	101	123	A	H
	*	5300	115.04	-	-	100.2	31.3	12.49	28.95	101	123	P	H
	*	5300	107.66	-	-	92.82	31.3	12.49	28.95	101	123	A	H
		5351.52	54.87	-19.13	74	40.11	31.21	12.53	28.98	101	123	P	H
		5351.76	44.88	-9.12	54	30.12	31.21	12.53	28.98	101	123	A	H
		5134.64	55.04	-18.96	74	39.85	31.73	12.3	28.84	103	98	P	V
		5148.24	42.93	-11.07	54	27.76	31.7	12.32	28.85	103	98	A	V
	*	5300	113.86	-	-	99.02	31.3	12.49	28.95	103	98	P	V
	*	5300	106.34	-	-	91.5	31.3	12.49	28.95	103	98	A	V
	5360.64	54.77	-19.23	74	39.98	31.24	12.54	28.99	103	98	P	V	
	5350.08	43.66	-10.34	54	28.91	31.2	12.53	28.98	103	98	A	V	



802.11n HT20 CH 64 5320MHz	*	5320	114.61	-	-	99.81	31.26	12.5	28.96	101	121	P	H
	*	5320	107.27	-	-	92.47	31.26	12.5	28.96	101	121	A	H
		5351.2	62.83	-11.17	74	48.08	31.2	12.53	28.98	101	121	P	H
		5350.08	51.18	-2.82	54	36.43	31.2	12.53	28.98	101	121	A	H
													H
													H
	*	5320	113.21	-	-	98.41	31.26	12.5	28.96	110	99	P	V
	*	5320	106.16	-	-	91.36	31.26	12.5	28.96	110	99	A	V
		5381.44	54.83	-19.17	74	39.94	31.33	12.56	29	110	99	P	V
		5350.08	45.46	-8.54	54	30.71	31.2	12.53	28.98	110	99	A	V
													V
													V
Remark	1. No other spurious found. 2. All results are PASS against Peak and Average limit line.												



Band 2 5250~5350MHz
WIFI 802.11n HT20 (Harmonic @ 3m)

WIFI Ant. 4+3	Note	Frequency (MHz)	Level (dBμV/m)	Over Limit (dB)	Limit Line (dBμV/m)	Read Level (dBμV)	Antenna Factor (dB/m)	Path Loss (dB)	Preamp Factor (dB)	Ant Pos (cm)	Table Pos (deg)	Peak Avg. (P/A)	Pol. (H/V)	
802.11n HT20 CH 52 5260MHz		10520	48.91	-19.29	68.2	50.59	40	19.42	61.1	100	0	P	H	
		15780	47.53	-26.47	74	47.42	37.3	24.37	61.56	100	0	P	H	
													H	
													H	
			10520	47.64	-20.56	68.2	49.32	40	19.42	61.1	100	0	P	V
			15780	46.57	-27.43	74	46.46	37.3	24.37	61.56	100	0	P	V
														V
802.11n HT20 CH 60 5300MHz		10600	48.73	-25.27	74	50.29	40	19.54	61.1	100	0	P	H	
		15900	46.19	-27.81	74	45.71	37.1	24.36	60.98	100	0	P	H	
													H	
													H	
			10600	48.48	-25.52	74	50.04	40	19.54	61.1	100	0	P	V
			15900	46.62	-27.38	74	46.14	37.1	24.36	60.98	100	0	P	V
														V
802.11n HT20 CH 64 5320MHz		10640	48.81	-25.19	74	50.31	40	19.6	61.1	100	0	P	H	
		15960	49	-25	74	48.29	37.04	24.36	60.69	100	0	P	H	
													H	
													H	
			10640	48.19	-25.81	74	49.69	40	19.6	61.1	100	0	P	V
			15960	48.47	-25.53	74	47.76	37.04	24.36	60.69	100	0	P	V
														V
Remark	1. No other spurious found.													
	2. All results are PASS against Peak and Average limit line.													



Band 2 5250~5350MHz
WIFI 802.11n HT40 (Band Edge @ 3m)

WIFI Ant. 4+3	Note	Frequency (MHz)	Level (dBμV/m)	Over Limit (dB)	Limit Line (dBμV/m)	Read Level (dBμV)	Antenna Factor (dB/m)	Path Loss (dB)	Preamp Factor (dB)	Ant Pos (cm)	Table Pos (deg)	Peak Avg. (P/A)	Pol. (H/V)
802.11n HT40 CH 54 5270MHz		5031.96	54.17	-19.83	74	39.15	31.63	12.16	28.77	101	122	P	H
		5083.3	45.1	-8.9	54	29.9	31.77	12.23	28.8	101	122	A	H
	*	5270	114.98	-	-	100.15	31.3	12.46	28.93	101	122	P	H
	*	5270	107.2	-	-	92.37	31.3	12.46	28.93	101	122	A	H
		5351.28	56.8	-17.2	74	42.04	31.21	12.53	28.98	101	122	P	H
		5350.8	48	-6	54	33.25	31.2	12.53	28.98	101	122	A	H
		5146.88	53.52	-20.48	74	38.34	31.71	12.32	28.85	101	100	P	V
		5140.42	45.12	-8.88	54	29.93	31.72	12.31	28.84	101	100	A	V
	*	5270	111.81	-	-	96.98	31.3	12.46	28.93	101	100	P	V
	*	5270	104.18	-	-	89.35	31.3	12.46	28.93	101	100	A	V
		5351.52	54.65	-19.35	74	39.89	31.21	12.53	28.98	101	100	P	V
		5350.08	45.71	-8.29	54	30.96	31.2	12.53	28.98	101	100	P	V
802.11n HT40 CH 62 5310MHz		5135.66	54.1	-19.9	74	38.91	31.73	12.3	28.84	100	124	P	H
		5149.26	42.86	-11.14	54	27.69	31.7	12.32	28.85	100	124	A	H
	*	5310	107.37	-	-	92.55	31.28	12.49	28.95	100	124	P	H
	*	5310	99.09	-	-	84.27	31.28	12.49	28.95	100	124	A	H
		5353.2	61.14	-12.86	74	46.37	31.21	12.54	28.98	100	124	P	H
		5350.08	51.48	-2.52	54	36.73	31.2	12.53	28.98	100	124	A	H
		5053.38	54.85	-19.15	74	39.74	31.71	12.19	28.79	100	102	P	V
		5089.08	42.82	-11.18	54	27.61	31.78	12.24	28.81	100	102	A	V
	*	5310	104.5	-	-	89.68	31.28	12.49	28.95	100	102	P	V
	*	5310	96.68	-	-	81.86	31.28	12.49	28.95	100	102	A	V
	5351.52	55.52	-18.48	74	40.76	31.21	12.53	28.98	100	102	P	V	
	5350.08	46.98	-7.02	54	32.23	31.2	12.53	28.98	100	102	A	V	
Remark	1. No other spurious found. 2. All results are PASS against Peak and Average limit line.												



Band 2 5250~5350MHz
WIFI 802.11n HT40 (Harmonic @ 3m)

WIFI Ant. 4+3	Note	Frequency (MHz)	Level (dBμV/m)	Over Limit (dB)	Limit Line (dBμV/m)	Read Level (dBμV)	Antenna Factor (dB/m)	Path Loss (dB)	Preamp Factor (dB)	Ant Pos (cm)	Table Pos (deg)	Peak Avg. (P/A)	Pol. (H/V)
802.11n HT40 CH 54 5270MHz		10540	47.72	-20.48	68.2	49.37	40	19.45	61.1	100	0	P	H
		15810	45.57	-28.43	74	45.33	37.28	24.37	61.41	100	0	P	H
													H
													H
		10540	47.49	-20.71	68.2	49.14	40	19.45	61.1	100	0	P	V
		15810	45.43	-28.57	74	45.19	37.28	24.37	61.41	100	0	P	V
													V
													V
802.11n HT40 CH 62 5310MHz		10620	48.21	-25.79	74	49.74	40	19.57	61.1	100	0	P	H
		15930	46.02	-27.98	74	45.42	37.07	24.37	60.84	100	0	P	H
													H
													H
		10620	48.43	-25.57	74	49.96	40	19.57	61.1	100	0	P	V
		15930	45.42	-28.58	74	44.82	37.07	24.37	60.84	100	0	P	V
													V
													V
Remark	1. No other spurious found. 2. All results are PASS against Peak and Average limit line.												



Band 2 5250~5350MHz
WIFI 802.11ac VHT80 (Band Edge @ 3m)

WIFI Ant. 4+3	Note	Frequency (MHz)	Level (dBμV/m)	Over Limit (dB)	Limit Line (dBμV/m)	Read Level (dBμV)	Antenna Factor (dB/m)	Path Loss (dB)	Preamp Factor (dB)	Ant Pos (cm)	Table Pos (deg)	Peak Avg. (P/A)	Pol. (H/V)
802.11ac VHT80 CH 58 5290MHz		5146.88	53.4	-20.6	74	38.22	31.71	12.32	28.85	100	123	P	H
		5145.86	45.03	-8.97	54	29.85	31.71	12.32	28.85	100	123	A	H
	*	5290	102.27	-	-	87.43	31.3	12.48	28.94	100	123	P	H
	*	5290	95.02	-	-	80.18	31.3	12.48	28.94	100	123	A	H
		5350.08	59.34	-14.66	74	44.59	31.2	12.53	28.98	100	123	P	H
		5350.32	51.65	-2.35	54	36.9	31.2	12.53	28.98	100	123	A	H
		5123.76	54.19	-19.81	74	38.98	31.75	12.29	28.83	100	102	P	V
		5141.1	45.06	-8.94	54	29.87	31.72	12.31	28.84	100	102	A	V
	*	5290	100.46	-	-	85.62	31.3	12.48	28.94	100	102	P	V
	*	5290	93.11	-	-	78.27	31.3	12.48	28.94	100	102	A	V
		5362.8	57.43	-16.57	74	42.63	31.25	12.54	28.99	100	102	P	V
	5360.4	48.47	-5.53	54	33.68	31.24	12.54	28.99	100	102	A	V	
Remark	1. No other spurious found. 2. All results are PASS against Peak and Average limit line.												



**Band 2 5250~5350MHz
WIFI 802.11ac VHT80 (Harmonic @ 3m)**

WIFI Ant. 4+3	Note	Frequency (MHz)	Level (dBμV/m)	Over Limit (dB)	Limit Line (dBμV/m)	Read Level (dBμV)	Antenna Factor (dB/m)	Path Loss (dB)	Preamp Factor (dB)	Ant Pos (cm)	Table Pos (deg)	Peak Avg. (P/A)	Pol. (H/V)	
802.11ac VHT80 CH 58 5290MHz		10580	48.39	-19.81	68.2	49.98	40	19.51	61.1	100	0	P	H	
		15870	45.73	-28.27	74	45.32	37.16	24.37	61.12	100	0	P	H	
													H	
													H	
			10580	48.27	-19.93	68.2	49.86	40	19.51	61.1	100	0	P	V
			15870	45.72	-28.28	74	45.31	37.16	24.37	61.12	100	0	P	V
														V
													V	
Remark	1. No other spurious found. 2. All results are PASS against Peak and Average limit line.													



Band 3 - 5470~5725MHz
WIFI 802.11a (Band Edge @ 3m)

WIFI	Note	Frequency	Level	Over	Limit	Read	Antenna	Path	Preamp	Ant	Table	Peak	Pol.	
Ant.				Limit	Line	Level	Factor	Loss	Factor	Pos	Pos	Avg.		
4+3		(MHz)	(dBμV/m)	(dB)	(dBμV/m)	(dBμV)	(dB/m)	(dB)	(dB)	(cm)	(deg)	(P/A)	(H/V)	
802.11a CH 100 5500MHz		5459.98	58.26	-15.74	74	43	31.62	12.69	29.05	100	119	P	H	
		5470	66.62	-1.58	68.2	51.33	31.64	12.71	29.06	100	119	P	H	
		5460	46.6	-7.4	54	31.34	31.62	12.69	29.05	100	119	A	H	
	*	5500	113.35	-	-	97.96	31.7	12.77	29.08	100	119	P	H	
	*	5500	106.29	-	-	90.9	31.7	12.77	29.08	100	119	A	H	
														H
			5459.98	57.58	-16.42	74	42.32	31.62	12.69	29.05	100	98	P	V
			5467.6	64.6	-3.6	68.2	49.31	31.64	12.71	29.06	100	98	P	V
			5459.6	46.53	-7.47	54	31.27	31.62	12.69	29.05	100	98	A	V
	*		5500	113.03	-	-	97.64	31.7	12.77	29.08	100	98	P	V
	*		5500	105.37	-	-	89.98	31.7	12.77	29.08	100	98	A	V
														V
802.11a CH 116 5580MHz		5364.16	54.91	-19.09	74	40.09	31.26	12.55	28.99	100	120	P	H	
		5465.44	54.07	-14.13	68.2	38.8	31.63	12.7	29.06	100	120	P	H	
		5458	42.23	-11.77	54	26.97	31.62	12.69	29.05	100	120	A	H	
	*	5580	115.15	-	-	99.55	31.74	12.92	29.06	100	120	P	H	
	*	5580	107.1	-	-	91.5	31.74	12.92	29.06	100	120	A	H	
			5750.195	54.16	-14.04	68.2	37.98	32	13.2	29.02	100	120	P	H
			5442.4	54.32	-19.68	74	39.13	31.57	12.66	29.04	100	101	P	V
			5461.84	54.03	-14.17	68.2	38.76	31.62	12.7	29.05	100	101	P	V
			5431.84	42.21	-11.79	54	27.08	31.53	12.64	29.04	100	101	A	V
	*		5580	114.44	-	-	98.84	31.74	12.92	29.06	100	101	P	V
	*		5580	106.94	-	-	91.34	31.74	12.92	29.06	100	101	A	V
			5733.5	54.78	-13.42	68.2	38.7	31.93	13.17	29.02	100	101	P	V



802.11a CH 140 5700MHz	*	5700	113.05	-	-	97.16	31.8	13.12	29.03	108	119	P	H
	*	5700	105.47	-	-	89.58	31.8	13.12	29.03	108	119	A	H
		5725.16	64.1	-4.1	68.2	48.07	31.9	13.16	29.03	108	119	P	H
													H
													H
													H
	*	5700	113.93	-	-	98.04	31.8	13.12	29.03	108	100	P	V
	*	5700	106.3	-	-	90.41	31.8	13.12	29.03	108	100	A	V
		5725	63.6	-4.6	68.2	47.57	31.9	13.16	29.03	108	100	P	V
													V
													V
													V
Remark	1. No other spurious found. 2. All results are PASS against Peak and Average limit line.												



Band 3 - 5470~5725MHz
WIFI 802.11a (Harmonic @ 3m)

WIFI Ant. 4+3	Note	Frequency (MHz)	Level (dBμV/m)	Over Limit (dB)	Limit Line (dBμV/m)	Read Level (dBμV)	Antenna Factor (dB/m)	Path Loss (dB)	Preamp Factor (dB)	Ant Pos (cm)	Table Pos (deg)	Peak Avg. (P/A)	Pol. (H/V)
802.11a CH 100 5500MHz		11000	50.88	-23.12	74	51.45	40.4	20.13	61.1	244	244	P	H
		11000	39.84	-14.16	54	40.41	40.4	20.13	61.1	244	244	A	H
		16500	48.68	-19.52	68.2	44.06	38.8	25.22	59.4	100	0	P	H
													H
		11000	51.05	-22.95	74	51.62	40.4	20.13	61.1	100	0	P	V
		11000	39.67	-14.33	54	40.24	40.4	20.13	61.1	100	0	A	V
		16500	48.7	-19.5	68.2	44.08	38.8	25.22	59.4	100	0	P	V
													V
802.11a CH 116 5580MHz		11160	49.81	-24.19	74	50.57	39.98	20.3	61.04	100	0	P	H
		16740	50.77	-17.43	68.2	44.6	39.8	25.63	59.26	100	0	P	H
													H
													H
		11160	50.24	-23.76	74	51	39.98	20.3	61.04	180	236	P	V
		11160	39.41	-14.59	54	40.17	39.98	20.3	61.04	180	236	A	V
		16740	50.85	-17.35	68.2	44.68	39.8	25.63	59.26	100	0	P	V
													V
802.11a CH 140 5700MHz		11400	48.95	-25.05	74	49.22	40.1	20.57	60.94	100	0	P	H
		17100	48.47	-19.73	68.2	40.9	40.3	26.25	58.98	100	0	P	H
													H
													H
		11400	49.26	-24.74	74	49.53	40.1	20.57	60.94	100	0	P	V
		17100	48.84	-19.36	68.2	41.27	40.3	26.25	58.98	100	0	P	V
													V
													V
Remark	1. No other spurious found. 2. All results are PASS against Peak and Average limit line.												



**Band 3 - 5470~5725MHz
WIFI 802.11n HT20 (Band Edge @ 3m)**

WIFI Ant. 4+3	Note	Frequency (MHz)	Level (dBμV/m)	Over Limit (dB)	Limit Line (dBμV/m)	Read Level (dBμV)	Antenna Factor (dB/m)	Path Loss (dB)	Preamp Factor (dB)	Ant Pos (cm)	Table Pos (deg)	Peak Avg. (P/A)	Pol. (H/V)	
802.11n HT20 CH 100 5500MHz		5453.2	57.16	-16.84	74	41.92	31.61	12.68	29.05	100	120	P	H	
		5469.84	66.55	-1.65	68.2	51.26	31.64	12.71	29.06	100	120	P	H	
		5458.48	46.22	-7.78	54	30.96	31.62	12.69	29.05	100	120	A	H	
	*	5500	111.7	-	-	96.31	31.7	12.77	29.08	100	120	P	H	
	*	5500	104.04	-	-	88.65	31.7	12.77	29.08	100	120	A	H	
														H
			5453.2	55.47	-18.53	74	40.23	31.61	12.68	29.05	110	98	P	V
			5466.96	61.93	-6.27	68.2	46.65	31.63	12.71	29.06	110	98	P	V
			5460	45.15	-8.85	54	29.89	31.62	12.69	29.05	110	98	A	V
	*		5500	112.3	-	-	96.91	31.7	12.77	29.08	110	98	P	V
	*		5500	104.7	-	-	89.31	31.7	12.77	29.08	110	98	A	V
													V	
802.11n HT20 CH 116 5580MHz		5443.6	54.84	-19.16	74	39.65	31.57	12.66	29.04	101	120	P	H	
		5464.72	53.12	-15.08	68.2	37.85	31.63	12.7	29.06	101	120	P	H	
		5459.2	42.21	-11.79	54	26.95	31.62	12.69	29.05	101	120	A	H	
	*	5580	114.31	-	-	98.71	31.74	12.92	29.06	101	120	P	H	
	*	5580	106.29	-	-	90.69	31.74	12.92	29.06	101	120	A	H	
			5746.1	54.37	-13.83	68.2	38.22	31.98	13.19	29.02	101	120	P	H
			5422.48	53.99	-20.01	74	38.91	31.49	12.62	29.03	100	95	P	V
			5462.8	52.82	-15.38	68.2	37.55	31.63	12.7	29.06	100	95	P	V
			5457.76	42.15	-11.85	54	26.89	31.62	12.69	29.05	100	95	A	V
	*		5580	114.79	-	-	99.19	31.74	12.92	29.06	100	95	P	V
	*		5580	107.43	-	-	91.83	31.74	12.92	29.06	100	95	A	V
		5744.525	56.03	-12.17	68.2	39.88	31.98	13.19	29.02	100	95	P	V	



802.11n HT20 CH 140 5700MHz	*	5700	111.88	-	-	95.99	31.8	13.12	29.03	101	121	P	H
	*	5700	104.29	-	-	88.4	31.8	13.12	29.03	101	121	A	H
		5725	64.45	-3.75	68.2	48.42	31.9	13.16	29.03	101	121	P	H
													H
													H
													H
	*	5700	111.19	-	-	95.3	31.8	13.12	29.03	101	98	P	V
	*	5700	102.74	-	-	86.85	31.8	13.12	29.03	101	98	A	V
		5725	65.09	-3.11	68.2	49.06	31.9	13.16	29.03	101	98	P	V
													V
													V
													V
Remark	1. No other spurious found. 2. All results are PASS against Peak and Average limit line.												



**Band 3 - 5470~5725MHz
WIFI 802.11n HT20 (Harmonic @ 3m)**

WIFI Ant. 4+3	Note	Frequency (MHz)	Level (dBμV/m)	Over Limit (dB)	Limit Line (dBμV/m)	Read Level (dBμV)	Antenna Factor (dB/m)	Path Loss (dB)	Preamp Factor (dB)	Ant Pos (cm)	Table Pos (deg)	Peak Avg. (P/A)	Pol. (H/V)
802.11n HT20 CH 100 5500MHz		11000	48.68	-25.32	74	49.25	40.4	20.13	61.1	100	0	P	H
		16500	47.14	-21.06	68.2	42.52	38.8	25.22	59.4	100	0	P	H
													H
													H
		11000	49.26	-24.74	74	49.83	40.4	20.13	61.1	100	0	P	V
		16500	47.72	-20.48	68.2	43.1	38.8	25.22	59.4	100	0	P	V
													V
802.11n HT20 CH 116 5580MHz		11160	49.37	-24.63	74	50.13	39.98	20.3	61.04	100	0	P	H
		16740	49.76	-18.44	68.2	43.59	39.8	25.63	59.26	100	0	P	H
													H
													H
		11160	49.39	-24.61	74	50.15	39.98	20.3	61.04	100	0	P	V
		16740	50.77	-17.43	68.2	44.6	39.8	25.63	59.26	100	0	P	V
													V
802.11n HT20 CH 140 5700MHz		11400	49.34	-24.66	74	49.61	40.1	20.57	60.94	100	0	P	H
		17100	48.7	-19.5	68.2	41.13	40.3	26.25	58.98	100	0	P	H
													H
													H
		11400	49.06	-24.94	74	49.33	40.1	20.57	60.94	100	0	P	V
		17100	48.5	-19.7	68.2	40.93	40.3	26.25	58.98	100	0	P	V
													V
Remark	1. No other spurious found.												
	2. All results are PASS against Peak and Average limit line.												



**Band 3 - 5470~5725MHz
WIFI 802.11n HT40 (Band Edge @ 3m)**

WIFI Ant. 4+3	Note	Frequency (MHz)	Level (dBμV/m)	Over Limit (dB)	Limit Line (dBμV/m)	Read Level (dBμV)	Antenna Factor (dB/m)	Path Loss (dB)	Preamp Factor (dB)	Ant Pos (cm)	Table Pos (deg)	Peak Avg. (P/A)	Pol. (H/V)
802.11n HT40 CH 102 5510MHz		5458.96	59.73	-14.27	74	44.47	31.62	12.69	29.05	100	120	P	H
		5465.44	65.36	-2.84	68.2	50.09	31.63	12.7	29.06	100	120	P	H
		5459.92	51.51	-2.49	54	36.25	31.62	12.69	29.05	100	120	A	H
	*	5510	105.84	-	-	90.41	31.72	12.79	29.08	100	120	P	H
	*	5510	98.31	-	-	82.88	31.72	12.79	29.08	100	120	A	H
		5761.85	54.96	-13.24	68.2	38.74	32.02	13.22	29.02	100	120	P	H
		5458.48	56.18	-17.82	74	40.92	31.62	12.69	29.05	107	98	P	V
		5470	65.86	-2.34	68.2	50.57	31.64	12.71	29.06	107	98	P	V
		5458.24	46.87	-7.13	54	31.61	31.62	12.69	29.05	107	98	A	V
	*	5510	105.24	-	-	89.81	31.72	12.79	29.08	107	98	P	V
	*	5510	97.53	-	-	82.1	31.72	12.79	29.08	107	98	A	V
		5763.74	53.86	-14.34	68.2	37.63	32.03	13.22	29.02	107	98	P	V
802.11n HT40 CH 110 5550MHz		5456.56	53.88	-20.12	74	38.63	31.61	12.69	29.05	100	122	P	H
		5466.16	54.79	-13.41	68.2	39.51	31.63	12.71	29.06	100	122	P	H
		5459.92	45.48	-8.52	54	30.22	31.62	12.69	29.05	100	122	A	H
	*	5550	111.15	-	-	95.56	31.8	12.86	29.07	100	122	P	H
	*	5550	103.01	-	-	87.42	31.8	12.86	29.07	100	122	A	H
		5755.865	54.26	-13.94	68.2	38.06	32.01	13.21	29.02	100	122	P	H
		5370.88	53.9	-20.1	74	39.06	31.28	12.55	28.99	105	98	P	V
		5470	54.29	-13.91	68.2	39	31.64	12.71	29.06	105	98	P	V
		5456.32	44.85	-9.15	54	29.6	31.61	12.69	29.05	105	98	A	V
	*	5550	111.05	-	-	95.46	31.8	12.86	29.07	105	98	P	V
	*	5550	103.16	-	-	87.57	31.8	12.86	29.07	105	98	A	V
		5763.11	54.27	-13.93	68.2	38.04	32.03	13.22	29.02	105	98	P	V



802.11n HT40 CH 134 5670MHz		5447.3	52.55	-21.45	74	37.34	31.59	12.67	29.05	100	120	P	H
		5466.9	51.56	-16.64	68.2	36.28	31.63	12.71	29.06	100	120	P	H
		5415.45	43.84	-10.16	54	28.79	31.46	12.61	29.02	100	120	A	H
	*	5670	112.72	-	-	96.95	31.74	13.07	29.04	100	120	P	H
	*	5670	104.4	-	-	88.63	31.74	13.07	29.04	100	120	A	H
		5731.05	66.52	-1.68	68.2	50.45	31.92	13.17	29.02	100	120	P	H
		5352.8	52.64	-21.36	74	37.87	31.21	12.54	28.98	104	93	P	V
		5465.5	52.26	-15.94	68.2	36.99	31.63	12.7	29.06	104	93	P	V
		5457.45	43.73	-10.27	54	28.48	31.61	12.69	29.05	104	93	A	V
	*	5670	111.29	-	-	95.52	31.74	13.07	29.04	104	93	P	V
	*	5670	103.09	-	-	87.32	31.74	13.07	29.04	104	93	A	V
		5726.5	64	-4.2	68.2	47.96	31.91	13.16	29.03	104	93	P	V
Remark	1. No other spurious found. 2. All results are PASS against Peak and Average limit line.												



Band 3 - 5470~5725MHz
WIFI 802.11n HT40 (Harmonic @ 3m)

WIFI Ant. 4+3	Note	Frequency (MHz)	Level (dBμV/m)	Over Limit (dB)	Limit Line (dBμV/m)	Read Level (dBμV)	Antenna Factor (dB/m)	Path Loss (dB)	Preamp Factor (dB)	Ant Pos (cm)	Table Pos (deg)	Peak Avg. (P/A)	Pol. (H/V)	
802.11n HT40 CH 102 5510MHz		11020	49.21	-24.79	74	49.81	40.34	20.15	61.09	100	0	P	H	
		16530	49.04	-19.16	68.2	44.2	38.95	25.27	59.38	100	0	P	H	
													H	
													H	
			11020	49.9	-24.1	74	50.5	40.34	20.15	61.09	100	0	P	V
			16530	48.17	-20.03	68.2	43.33	38.95	25.27	59.38	100	0	P	V
														V
802.11n HT40 CH 110 5550MHz		11100	48.32	-25.68	74	49.04	40.1	20.24	61.06	100	0	P	H	
		16650	47.84	-20.36	68.2	42.23	39.45	25.47	59.31	100	0	P	H	
													H	
													H	
			11100	47.95	-26.05	74	48.67	40.1	20.24	61.06	100	0	P	V
			16650	49.01	-19.19	68.2	43.4	39.45	25.47	59.31	100	0	P	V
														V
802.11n HT40 CH 134 5670MHz		11340	48.39	-25.61	74	48.93	39.92	20.5	60.96	100	0	P	H	
		17010	50.41	-17.79	68.2	42.83	40.57	26.1	59.09	100	0	P	H	
													H	
													H	
			11340	48.88	-25.12	74	49.42	39.92	20.5	60.96	100	0	P	V
			17010	49.01	-19.19	68.2	41.43	40.57	26.1	59.09	100	0	P	V
														V
Remark	1. No other spurious found.													
	2. All results are PASS against Peak and Average limit line.													



Band 3 - 5470~5725MHz
WIFI 802.11ac VHT80 (Band Edge @ 3m)

WIFI Ant. 4+3	Note	Frequency (MHz)	Level (dBμV/m)	Over Limit (dB)	Limit Line (dBμV/m)	Read Level (dBμV)	Antenna Factor (dB/m)	Path Loss (dB)	Preamp Factor (dB)	Ant Pos (cm)	Table Pos (deg)	Peak Avg. (P/A)	Pol. (H/V)
802.11ac VHT80 CH 106 5530MHz		5443.12	59.11	-14.89	74	43.92	31.57	12.66	29.04	101	121	P	H
		5464.72	60.87	-7.33	68.2	45.6	31.63	12.7	29.06	101	121	P	H
		5459.92	51.37	-2.63	54	36.11	31.62	12.69	29.05	101	121	A	H
	*	5530	101.16	-	-	85.64	31.76	12.83	29.07	101	121	P	H
	*	5530	93.54	-	-	78.02	31.76	12.83	29.07	101	121	A	H
		5731.295	54.22	-13.98	68.2	38.14	31.93	13.17	29.02	101	121	P	H
		5456.56	56.53	-17.47	74	41.28	31.61	12.69	29.05	100	101	P	V
		5469.52	57.29	-10.91	68.2	42	31.64	12.71	29.06	100	101	P	V
		5456.56	49.1	-4.9	54	33.85	31.61	12.69	29.05	100	101	A	V
	*	5530	99.51	-	-	83.99	31.76	12.83	29.07	100	101	P	V
	*	5530	91.72	-	-	76.2	31.76	12.83	29.07	100	101	A	V
	5751.455	53.59	-14.61	68.2	37.41	32	13.2	29.02	100	101	P	V	
802.11ac VHT80 CH 122 5610MHz		5451.76	54.85	-19.15	74	39.62	31.6	12.68	29.05	100	121	P	H
		5466.16	56.15	-12.05	68.2	40.87	31.63	12.71	29.06	100	121	P	H
		5453.68	46.14	-7.86	54	30.9	31.61	12.68	29.05	100	121	A	H
	*	5610	109.75	-	-	94.12	31.7	12.98	29.05	100	121	P	H
	*	5610	101.89	-	-	86.26	31.7	12.98	29.05	100	121	A	H
		5728.46	59.52	-8.68	68.2	43.47	31.91	13.17	29.03	100	121	P	H
		5443.36	54.87	-19.13	74	39.68	31.57	12.66	29.04	104	97	P	V
		5466.88	56.24	-11.96	68.2	40.96	31.63	12.71	29.06	104	97	P	V
		5458	45.47	-8.53	54	30.21	31.62	12.69	29.05	104	97	A	V
	*	5610	109.29	-	-	93.66	31.7	12.98	29.05	104	97	P	V
	*	5610	102.4	-	-	86.77	31.7	12.98	29.05	104	97	A	V
	5731.61	59.51	-8.69	68.2	43.43	31.93	13.17	29.02	104	97	P	V	
Remark	1. No other spurious found. 2. All results are PASS against Peak and Average limit line.												



**Band 3 5470~5725MHz
WIFI 802.11ac VHT80 (Harmonic @ 3m)**

WIFI Ant. 4+3	Note	Frequency (MHz)	Level (dBμV/m)	Over Limit (dB)	Limit Line (dBμV/m)	Read Level (dBμV)	Antenna Factor (dB/m)	Path Loss (dB)	Preamp Factor (dB)	Ant Pos (cm)	Table Pos (deg)	Peak Avg. (P/A)	Pol. (H/V)	
802.11ac VHT80 CH 106 5530MHz		11060	48.9	-25.1	74	49.56	40.22	20.2	61.08	100	0	P	H	
		16590	49.1	-19.1	68.2	43.83	39.25	25.37	59.35	100	0	P	H	
													H	
													H	
			11060	48.68	-25.32	74	49.34	40.22	20.2	61.08	100	0	P	V
			16590	49.63	-18.57	68.2	44.36	39.25	25.37	59.35	100	0	P	V
														V
802.11ac VHT80 CH 122 5610MHz		11220	49.15	-24.85	74	49.91	39.88	20.37	61.01	100	0	P	H	
		16830	49.2	-19	68.2	42.37	40.25	25.78	59.2	100	0	P	H	
													H	
													H	
			11220	49.48	-24.52	74	50.24	39.88	20.37	61.01	100	0	P	V
			16830	48.79	-19.41	68.2	41.96	40.25	25.78	59.2	100	0	P	V
														V
Remark	1. No other spurious found.													
	2. All results are PASS against Peak and Average limit line.													



Band 3 - Straddle Channel
WIFI 802.11a (Band Edge @ 3m)

WIFI	Note	Frequency	Level	Over	Limit	Read	Antenna	Path	Preamp	Ant	Table	Peak	Pol.
Ant.				Limit	Line	Level	Factor	Loss	Factor	Pos	Pos	Avg.	
4+3		(MHz)	(dBμV/m)	(dB)	(dBμV/m)	(dBμV)	(dB/m)	(dB)	(dB)	(cm)	(deg)	(P/A)	(H/V)
802.11a CH 144 5720MHz		5440.48	54.56	-19.44	74	39.38	31.56	12.66	29.04	100	120	P	H
		5462.71	54.03	-14.17	68.2	38.76	31.63	12.7	29.06	100	120	P	H
		5455.69	42.09	-11.91	54	26.84	31.61	12.69	29.05	100	120	A	H
	*	5720	114.39	-	-	98.39	31.88	13.15	29.03	100	120	P	H
	*	5720	107.09	-	-	91.09	31.88	13.15	29.03	100	120	A	H
		5927	57.01	-11.19	68.2	40.32	32.31	13.36	28.98	100	120	P	H
		5398.36	54.87	-19.13	74	39.91	31.39	12.58	29.01	100	101	P	V
		5466.22	54.65	-13.55	68.2	39.37	31.63	12.71	29.06	100	101	P	V
		5456.47	42.09	-11.91	54	26.84	31.61	12.69	29.05	100	101	A	V
	*	5720	115.1	-	-	99.1	31.88	13.15	29.03	100	101	P	V
	*	5720	107.38	-	-	91.38	31.88	13.15	29.03	100	101	A	V
			5884.75	57.96	-10.24	68.2	41.45	32.17	13.33	28.99	100	101	P
Remark	1. No other spurious found. 2. All results are PASS against Peak and Average limit line.												



**Band 3 - Straddle Channel
WIFI 802.11a (Harmonic @ 3m)**

WIFI Ant. 4+3	Note	Frequency (MHz)	Level (dBμV/m)	Over Limit (dB)	Limit Line (dBμV/m)	Read Level (dBμV)	Antenna Factor (dB/m)	Path Loss (dB)	Preamp Factor (dB)	Ant Pos (cm)	Table Pos (deg)	Peak Avg. (P/A)	Pol. (H/V)	
802.11a CH 144 5720MHz		11440	49.45	-24.55	74	49.66	40.1	20.61	60.92	100	0	P	H	
		17160	49.56	-18.64	68.2	41.58	40.54	26.35	58.91	100	0	P	H	
													H	
													H	
			11440	49.83	-24.17	74	50.04	40.1	20.61	60.92	100	0	P	V
			17160	49.97	-18.23	68.2	41.99	40.54	26.35	58.91	100	0	P	V
														V
														V
Remark	1. No other spurious found. 2. All results are PASS against Peak and Average limit line.													



Band 3 - Straddle Channel
WIFI 802.11n HT20 (Band Edge @ 3m)

WIFI Ant. 4+3	Note	Frequency (MHz)	Level (dBμV/m)	Over Limit (dB)	Limit Line (dBμV/m)	Read Level (dBμV)	Antenna Factor (dB/m)	Path Loss (dB)	Preamp Factor (dB)	Ant Pos (cm)	Table Pos (deg)	Peak Avg. (P/A)	Pol. (H/V)
802.11n HT20 CH 144 5720MHz		5412.4	55.07	-18.93	74	40.04	31.45	12.6	29.02	100	121	P	H
		5462.71	54.34	-13.86	68.2	39.07	31.63	12.7	29.06	100	121	P	H
		5455.69	41.97	-12.03	54	26.72	31.61	12.69	29.05	100	121	A	H
	*	5720	112.87	-	-	96.87	31.88	13.15	29.03	100	121	P	H
	*	5720	104.93	-	-	88.93	31.88	13.15	29.03	100	121	A	H
		5943.75	58.03	-10.17	68.2	41.25	32.38	13.37	28.97	100	121	P	H
		5396.02	55.31	-18.69	74	40.36	31.38	12.58	29.01	102	93	P	V
		5468.56	53.95	-14.25	68.2	38.66	31.64	12.71	29.06	102	93	P	V
		5456.86	41.84	-12.16	54	26.59	31.61	12.69	29.05	102	93	A	V
	*	5728	111.46	-	-	95.42	31.91	13.16	29.03	102	93	P	V
	*	5728	102.72	-	-	86.68	31.91	13.16	29.03	102	93	A	V
		5899.5	58.34	-9.86	68.2	41.78	32.2	13.34	28.98	102	93	P	V
Remark	1. No other spurious found. 2. All results are PASS against Peak and Average limit line.												



Band 3 - Straddle Channel
WIFI 802.11n HT20 (Harmonic @ 3m)

WIFI Ant. 4+3	Note	Frequency (MHz)	Level (dBμV/m)	Over Limit (dB)	Limit Line (dBμV/m)	Read Level (dBμV)	Antenna Factor (dB/m)	Path Loss (dB)	Preamp Factor (dB)	Ant Pos (cm)	Table Pos (deg)	Peak Avg. (P/A)	Pol. (H/V)	
802.11n HT20 CH 144 5720MHz		11440	49.76	-24.24	74	49.97	40.1	20.61	60.92	100	0	P	H	
		17160	49.67	-18.53	68.2	41.69	40.54	26.35	58.91	100	0	P	H	
													H	
													H	
			11440	48.81	-25.19	74	49.02	40.1	20.61	60.92	100	0	P	V
			17160	48.9	-19.3	68.2	40.92	40.54	26.35	58.91	100	0	P	V
														V
														V
Remark	1. No other spurious found. 2. All results are PASS against Peak and Average limit line.													



Band 3 - Straddle Channel
WIFI 802.11n HT40 (Band Edge @ 3m)

WIFI Ant. 4+3	Note	Frequency (MHz)	Level (dBμV/m)	Over Limit (dB)	Limit Line (dBμV/m)	Read Level (dBμV)	Antenna Factor (dB/m)	Path Loss (dB)	Preamp Factor (dB)	Ant Pos (cm)	Table Pos (deg)	Peak Avg. (P/A)	Pol. (H/V)
802.11n HT40 CH 142 5710MHz		5455.3	53.56	-20.44	74	38.31	31.61	12.69	29.05	100	120	P	H
		5468.56	52.24	-15.96	68.2	36.95	31.64	12.71	29.06	100	120	P	H
		5455.3	43.86	-10.14	54	28.61	31.61	12.69	29.05	100	120	A	H
	*	5710	112.44	-	-	96.49	31.84	13.14	29.03	100	120	P	H
	*	5710	104.53	-	-	88.58	31.84	13.14	29.03	100	120	A	H
		5862.25	56.28	-11.92	68.2	39.83	32.12	13.32	28.99	100	120	P	H
		5442.82	53.36	-20.64	74	38.17	31.57	12.66	29.04	101	95	P	V
		5468.56	52.45	-15.75	68.2	37.16	31.64	12.71	29.06	101	95	P	V
		5447.5	44.12	-9.88	54	28.91	31.59	12.67	29.05	101	95	A	V
	*	5710	111.79	-	-	95.84	31.84	13.14	29.03	101	95	P	V
	*	5710	104	-	-	88.05	31.84	13.14	29.03	101	95	A	V
		5866.25	55.14	-13.06	68.2	38.68	32.13	13.32	28.99	101	95	P	V
Remark	1. No other spurious found. 2. All results are PASS against Peak and Average limit line.												



Band 3 - Straddle Channel
WIFI 802.11n HT40 (Harmonic @ 3m)

WIFI Ant. 4+3	Note	Frequency (MHz)	Level (dBμV/m)	Over Limit (dB)	Limit Line (dBμV/m)	Read Level (dBμV)	Antenna Factor (dB/m)	Path Loss (dB)	Preamp Factor (dB)	Ant Pos (cm)	Table Pos (deg)	Peak Avg. (P/A)	Pol. (H/V)
802.11n HT40		11420	48.92	-25.08	74	49.16	40.1	20.59	60.93	100	0	P	H
		17130	50.7	-17.5	68.2	42.92	40.42	26.3	58.94	100	0	P	H
													H
													H
CH 142 5710MHz		11420	49.78	-24.22	74	50.02	40.1	20.59	60.93	100	0	P	V
		17130	50.74	-17.46	68.2	42.96	40.42	26.3	58.94	100	0	P	V
													V
													V
Remark	1. No other spurious found. 2. All results are PASS against Peak and Average limit line.												



Band 3 - Straddle Channel
WIFI 802.11ac VHT80 (Band Edge @ 3m)

WIFI Ant. 4+3	Note	Frequency (MHz)	Level (dBμV/m)	Over Limit (dB)	Limit Line (dBμV/m)	Read Level (dBμV)	Antenna Factor (dB/m)	Path Loss (dB)	Preamp Factor (dB)	Ant Pos (cm)	Table Pos (deg)	Peak Avg. (P/A)	Pol. (H/V)
802.11ac VHT80 CH 138 5690MHz		5425.27	54.88	-19.12	74	39.78	31.5	12.63	29.03	101	121	P	H
		5464.27	53.17	-15.03	68.2	37.9	31.63	12.7	29.06	101	121	P	H
		5458.42	44.34	-9.66	54	29.08	31.62	12.69	29.05	101	121	A	H
	*	5690	109.7	-	-	93.85	31.78	13.1	29.03	101	121	P	H
	*	5690	101.91	-	-	86.06	31.78	13.1	29.03	101	121	A	H
		5941.75	56.2	-12	68.2	39.43	32.37	13.37	28.97	101	121	P	H
		5444.77	53.43	-20.57	74	38.22	31.58	12.67	29.04	100	94	P	V
		5463.88	53.32	-14.88	68.2	38.05	31.63	12.7	29.06	100	94	P	V
		5457.64	44.08	-9.92	54	28.82	31.62	12.69	29.05	100	94	A	V
	*	5690	109.38	-	-	93.53	31.78	13.1	29.03	100	94	P	V
	*	5690	101.35	-	-	85.5	31.78	13.1	29.03	100	94	A	V
		5857.25	55.83	-12.37	68.2	39.4	32.11	13.31	28.99	100	94	P	V
Remark	1. No other spurious found. 2. All results are PASS against Peak and Average limit line.												



**Band 3 - Straddle Channel
WIFI 802.11ac VHT80 (Harmonic @ 3m)**

WIFI Ant. 4+3	Note	Frequency (MHz)	Level (dBμV/m)	Over Limit (dB)	Limit Line (dBμV/m)	Read Level (dBμV)	Antenna Factor (dB/m)	Path Loss (dB)	Preamp Factor (dB)	Ant Pos (cm)	Table Pos (deg)	Peak Avg. (P/A)	Pol. (H/V)	
802.11ac VHT80 CH 138 5690MHz		11380	49.53	-24.47	74	49.9	40.04	20.54	60.95	100	0	P	H	
		17070	50.09	-18.11	68.2	42.52	40.39	26.2	59.02	100	0	P	H	
													H	
													H	
			11380	49.43	-24.57	74	49.8	40.04	20.54	60.95	100	0	P	V
			17070	49.87	-18.33	68.2	42.3	40.39	26.2	59.02	100	0	P	V
														V
														V
Remark	1. No other spurious found. 2. All results are PASS against Peak and Average limit line.													



Emission above 18GHz

WIFI 802.11a (SHF @ 3m)

WIFI	Note	Frequency	Level	Over	Limit	Read	Antenna	Path	Preamp	Ant	Table	Peak	Pol.	
Ant.				Limit	Line	Level	Factor	Loss	Factor	Pos	Pos	Avg.		
4+3		(MHz)	(dBµV/m)	(dB)	(dBµV/m)	(dBµV)	(dB/m)	(dB)	(dB)	(cm)	(deg)	(P/A)	(H/V)	
802.11a SHF		33312	44.02	-24.18	68.2	39.62	40.84	17.78	54.22	150	0	P	H	
		38504	46.21	-21.99	68.2	38.88	44	19.22	55.89	150	0	P	H	
												P	H	
												P	H	
												P	H	
												P	H	
												P	H	
												P	H	
												P	H	
												P	H	
												P	H	
												P	H	
												P	H	
												P	H	
												P	H	
												P	H	
												P	H	
												P	H	
			23522	41.65	-26.55	68.2	42.19	39.73	13.03	53.3	150	0	P	V
			38108	47.07	-21.13	68.2	39.91	43.29	19.85	55.98	150	0	P	V
												P	V	
												P	V	
												P	V	
												P	V	
												P	V	
												P	V	
												P	V	
												P	V	
												P	V	
												P	V	
												P	V	
Remark	1. No other spurious found. 2. All results are PASS against limit line.													



Emission below 1GHz

WIFI 802.11a (LF @ 3m)

WIFI	Note	Frequency	Level	Over	Limit	Read	Antenna	Path	Preamp	Ant	Table	Peak	Pol.	
Ant.				Limit	Line	Level	Factor	Loss	Factor	Pos	Pos	Avg.		
4+3		(MHz)	(dBμV/m)	(dB)	(dBμV/m)	(dBμV)	(dB/m)	(dB)	(dB)	(cm)	(deg)	(P/A)	(H/V)	
802.11a LF		40.67	32.69	-7.31	40	45.03	18.91	1.07	32.32	100	0	P	H	
		164.83	31.63	-11.87	43.5	45.67	15.99	2.27	32.3	-	-	P	H	
		310.33	29.14	-16.86	46	39.06	19.34	3.08	32.34	-	-	P	H	
		468.44	26.09	-19.91	46	31.07	23.48	3.66	32.12	-	-	P	H	
		598.42	28.81	-17.19	46	30.94	25.58	4.21	31.92	-	-	P	H	
		714.82	31.79	-14.21	46	32.63	26.75	4.59	32.18	-	-	P	H	
														H
														H
														H
														H
														H
														H
														H
			40.67	38.41	-1.59	40	50.75	18.91	1.07	32.32	100	182	Q	V
			184.23	28.23	-15.27	43.5	43.41	14.77	2.36	32.31	-	-	P	V
			465.53	25.4	-20.6	46	30.45	23.43	3.65	32.13	-	-	P	V
			582.9	29.09	-16.91	46	31.13	25.77	4.14	31.95	-	-	P	V
			719.67	31.72	-14.28	46	32.36	26.94	4.61	32.19	-	-	P	V
			876.81	33.59	-12.41	46	31.51	29.01	5.09	32.02	-	-	P	V
														V
													V	
													V	
													V	
													V	
													V	
Remark	1. No other spurious found. 2. All results are PASS against limit line.													



<WPC Mode>

Band 3 - 5470~5725MHz
WIFI 802.11a (Band Edge @ 3m)

WIFI Ant. 1+2	Note	Frequency (MHz)	Level (dBμV/m)	Over Limit (dB)	Limit Line (dBμV/m)	Read Level (dBμV)	Antenna Factor (dB/m)	Path Loss (dB)	Preamp Factor (dB)	Ant Pos (cm)	Table Pos (deg)	Peak Avg. (P/A)	Pol. (H/V)	
802.11a CH 100 5500MHz		5459.98	58.5	-15.5	74	43.24	31.62	12.69	29.05	100	268	P	H	
		5470	65.94	-2.26	68.2	50.65	31.64	12.71	29.06	100	268	P	H	
		5460	46.01	-7.99	54	30.75	31.62	12.69	29.05	100	268	A	H	
	*	5500	110.9	-	-	95.51	31.7	12.77	29.08	100	268	P	H	
	*	5500	103.88	-	-	88.49	31.7	12.77	29.08	100	268	A	H	
														H
			5457.68	56.54	-17.46	74	41.28	31.62	12.69	29.05	297	260	P	V
			5466.8	63.7	-4.5	68.2	48.42	31.63	12.71	29.06	297	260	P	V
			5457.68	45.14	-8.86	54	29.88	31.62	12.69	29.05	297	260	A	V
	*		5500	111.68	-	-	96.29	31.7	12.77	29.08	297	260	P	V
	*		5500	104.38	-	-	88.99	31.7	12.77	29.08	297	260	A	V
														V
Remark	1. No other spurious found. 2. All results are PASS against Peak and Average limit line.													



Band 3 - 5470~5725MHz
WIFI 802.11a (Harmonic @ 3m)

WIFI Ant. 1+2	Note	Frequency (MHz)	Level (dBμV/m)	Over Limit (dB)	Limit Line (dBμV/m)	Read Level (dBμV)	Antenna Factor (dB/m)	Path Loss (dB)	Preamp Factor (dB)	Ant Pos (cm)	Table Pos (deg)	Peak Avg. (P/A)	Pol. (H/V)	
802.11a CH 100 5500MHz		11000	49.98	-24.02	74	50.55	40.4	20.13	61.1	100	0	P	H	
		16500	49.12	-19.08	68.2	44.5	38.8	25.22	59.4	100	0	P	H	
													H	
													H	
													H	
													H	
													H	
													H	
													H	
			11000	49.7	-24.3	74	50.27	40.4	20.13	61.1	100	0	P	V
			16500	48.69	-19.51	68.2	44.07	38.8	25.22	59.4	100	0	P	V
														V
														V
														V
														V
														V
	Remark	1. No other spurious found. 2. All results are PASS against Peak and Average limit line.												



Emission above 18GHz

WIFI 802.11a (SHF @ 3m)

WIFI	Note	Frequency	Level	Over	Limit	Read	Antenna	Path	Preamp	Ant	Table	Peak	Pol.	
Ant.				Limit	Line	Level	Factor	Loss	Factor	Pos	Pos	Avg.		
1+2		(MHz)	(dBμV/m)	(dB)	(dBμV/m)	(dBμV)	(dB/m)	(dB)	(dB)	(cm)	(deg)	(P/A)	(H/V)	
802.11a SHF		33312	44.02	-24.18	68.2	39.62	40.84	17.78	54.22	150	0	P	H	
		35864	44.33	-23.87	68.2	40.06	42.52	18	56.25	150	0	P	H	
													H	
													H	
													H	
													H	
													H	
													H	
													H	
													H	
													H	
			27614	42.13	-26.07	68.2	40.56	39.44	15.44	53.31	150	0	P	V
			36128	45.62	-22.58	68.2	41.03	42.65	18.42	56.48	150	0	P	V
														V
														V
														V
														V
														V
													V	
Remark	1. No other spurious found. 2. All results are PASS against limit line.													



Emission below 1GHz

WIFI 802.11a (LF @ 3m)

WIFI	Note	Frequency	Level	Over	Limit	Read	Antenna	Path	Preamp	Ant	Table	Peak	Pol.	
Ant.				Limit	Line	Level	Factor	Loss	Factor	Pos	Pos	Avg.		
1+2		(MHz)	(dBμV/m)	(dB)	(dBμV/m)	(dBμV)	(dB/m)	(dB)	(dB)	(cm)	(deg)	(P/A)	(H/V)	
802.11a LF		94.02	31.02	-12.48	43.5	46.45	15.2	1.64	32.27	-	-	P	H	
		145.43	36.97	-6.53	43.5	49.97	17.16	2.12	32.28	100	44	Q	H	
		257.95	30.16	-15.84	46	39.93	19.76	2.81	32.34	-	-	P	H	
		424.79	25.55	-20.45	46	31.4	22.8	3.52	32.17	-	-	P	H	
		624.61	29.14	-16.86	46	30.88	25.96	4.28	31.98	-	-	P	H	
		772.05	31.36	-14.64	46	30.75	28.14	4.78	32.31	-	-	P	H	
														H
														H
														H
														H
														H
														H
			93.05	33.04	-10.46	43.5	48.65	15.04	1.63	32.28	-	-	P	V
			142.52	36.45	-7.05	43.5	49.44	17.19	2.1	32.28	100	0	P	V
			257.95	27.26	-18.74	46	37.03	19.76	2.81	32.34	-	-	P	V
			446.13	25.7	-20.3	46	31.19	23.06	3.6	32.15	-	-	P	V
			703.18	35.68	-10.32	46	36.84	26.45	4.55	32.16	-	-	P	V
			842.86	31.98	-14.02	46	30.18	28.98	5	32.18	-	-	P	V
													V	
													V	
													V	
													V	
													V	
													V	
Remark	1. No other spurious found. 2. All results are PASS against limit line.													



Note symbol

*	Fundamental Frequency which can be ignored. However, the level of any unwanted emissions shall not exceed the level of the fundamental frequency.
!	Test result is over limit line.
P/A	Peak or Average
H/V	Horizontal or Vertical



A calculation example for radiated spurious emission is shown as below:

WIFI	Note	Frequency	Level	Over	Limit	Read	Antenna	Path	Preamp	Ant	Table	Peak	Pol.
Ant.				Limit	Line	Level	Factor	Loss	Factor	Pos	Pos	Avg.	
4+3		(MHz)	(dBμV/m)	(dB)	(dBμV/m)	(dBμV)	(dB/m)	(dB)	(dB)	(cm)	(deg)	(P/A)	(H/V)
802.11b		2390	55.45	-18.55	74	54.51	32.22	4.58	35.86	103	308	P	H
CH 01													
2412MHz		2390	43.54	-10.46	54	42.6	32.22	4.58	35.86	103	308	A	H

1. Path Loss(dB) = Cable loss(dB) + Filter loss(dB) + Attenuator loss(dB)
2. Level(dBμV/m) = Antenna Factor(dB/m) + Path Loss(dB) + Read Level(dBμV) - Preamp Factor(dB)
3. Over Limit(dB) = Level(dBμV/m) – Limit Line(dBμV/m)

For Peak Limit @ 2390MHz:

1. Level(dBμV/m)
= Antenna Factor(dB/m) + Path Loss(dB) + Read Level(dBμV) - Preamp Factor(dB)
= 32.22(dB/m) + 4.58(dB) + 54.51(dBμV) – 35.86 (dB)
= 55.45 (dBμV/m)
2. Over Limit(dB)
= Level(dBμV/m) – Limit Line(dBμV/m)
= 55.45(dBμV/m) – 74(dBμV/m)
= -18.55(dB)

For Average Limit @ 2390MHz:

1. Level(dBμV/m)
= Antenna Factor(dB/m) + Path Loss(dB) + Read Level(dBμV) - Preamp Factor(dB)
= 32.22(dB/m) + 4.58(dB) + 42.6(dBμV) – 35.86 (dB)
= 43.54 (dBμV/m)
2. Over Limit(dB) = Level(dBμV/m) – Limit Line(dBμV/m)
= 43.54(dBμV/m) – 54(dBμV/m)
= -10.46(dB)

Both peak and average measured complies with the limit line, so test result is “PASS”.



Appendix D. Radiated Spurious Emission

Test Engineer :	Karl Hou, CR Liao, and Andy Yang	Temperature :	20~25°C
		Relative Humidity :	50~60%

Note symbol

-L	Low channel location
-R	High channel location



Band 1 - 5150~5250MHz
WIFI 802.11a (Band Edge @ 3m)

WIFI	Band 1 5150~5250MHz Band Edge @ 3m	
ANT	802.11a CH36 5180MHz	
4+3	Horizontal	Fundamental
Peak	<p>Site : 03CH16-HY Condition : PEAK_BE_74 3m 91200_1522 HORIZONTAL RBW:1000.000KHz VBW:3000.000KHz SWT:Auto Detector : Peak</p>	<p>Site : 03CH16-HY Condition : PEAK(UNIT) 3m 91200_1522 HORIZONTAL RBW:1000.000KHz VBW:3000.000KHz SWT:Auto Detector : Peak</p>
Avg.	<p>Site : 03CH16-HY Condition : AVG_BE_54 3m 91200_1522 HORIZONTAL RBW:1000.000KHz VBW:0.010KHz SWT:Auto Detector : Peak</p>	Left blank

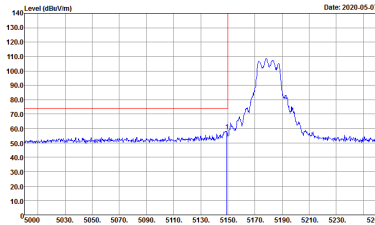
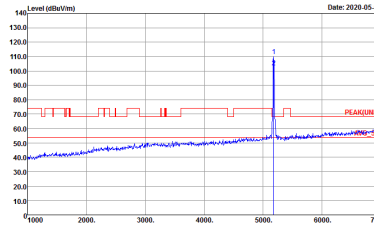

WIFI	Band 1 5150~5250MHz Band Edge @ 3m	
ANT	802.11a CH36 5180MHz	
4+3	Vertical	Fundamental
<p>Peak</p>	 <p>Site : 03CH16-HY Condition : PEAK_BE_74 3m 91200_1522 VERTICAL RBW:1000.000KHz VBW:3000.000KHz SWT:Auto Detector : Peak</p>	 <p>Site : 03CH16-HY Condition : PEAK(UNIT) 3m 91200_1522 VERTICAL RBW:1000.000KHz VBW:3000.000KHz SWT:Auto Detector : Peak</p>
<p>Avg.</p>	 <p>Site : 03CH16-HY Condition : AVG_BE_54 3m 91200_1522 VERTICAL RBW:1000.000KHz VBW:0.010KHz SWT:Auto Detector : Peak</p>	<p>Left blank</p>

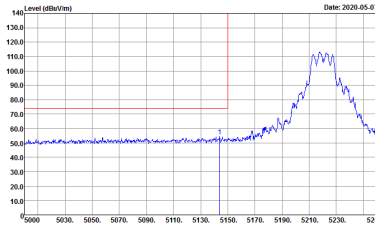
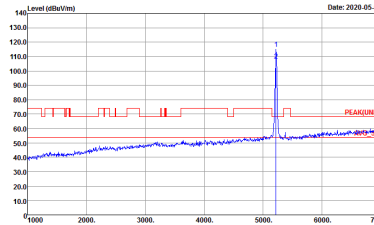
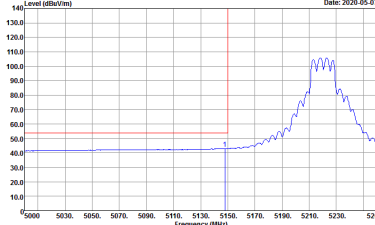

WIFI	Band 1 5150~5250MHz Band Edge @ 3m	
ANT	802.11a CH44 5220MHz - L	
4+3	Horizontal	Fundamental
<p>Peak</p>	 <p>Site : 03CH16-HY Condition : PEAK_BE_74 3m 91200_1522 HORIZONTAL RBW:1000.000KHz VBW:3000.000KHz SWT:Auto Detector : Peak</p>	 <p>Site : 03CH16-HY Condition : PEAK(UNIT) 3m 91200_1522 HORIZONTAL RBW:1000.000KHz VBW:3000.000KHz SWT:Auto Detector : Peak</p>
<p>Avg.</p>	 <p>Site : 03CH16-HY Condition : AVG_BE_54 3m 91200_1522 HORIZONTAL RBW:1000.000KHz VBW:0.010KHz SWT:Auto Detector : Peak</p>	<p>Left blank</p>



WIFI	Band 1 5150~5250MHz Band Edge @ 3m	
ANT	802.11a CH44 5220MHz - R	
4+3	Horizontal	Fundamental
<p>Peak</p>	<p>Site : 03CH16-HY Condition : PEAK_BE_74 3m 91200_1522 HORIZONTAL RBW:1000.000KHz VBW:3000.000KHz SWT:Auto Detector : Peak</p>	<p>Left blank</p>
<p>Avg.</p>	<p>Site : 03CH16-HY Condition : AVG_BE_54 3m 91200_1522 HORIZONTAL RBW:1000.000KHz VBW:0.010KHz SWT:Auto Detector : Peak</p>	<p>Left blank</p>

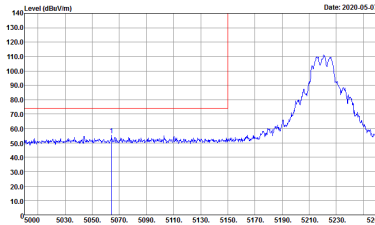
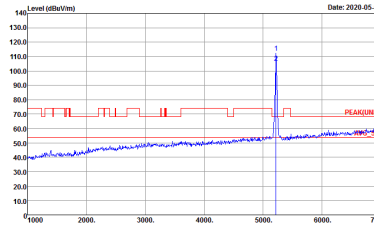
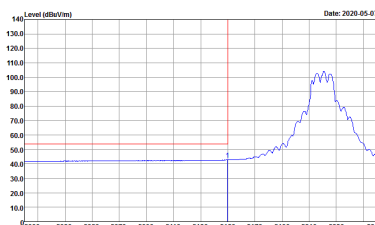

WIFI	Band 1 5150~5250MHz Band Edge @ 3m	
ANT	802.11a CH44 5220MHz - L	
4+3	Vertical	Fundamental
<p>Peak</p>	 <p>Site : 03CH16-HY Condition : PEAK_BE_74 3m 91200_1522 VERTICAL RBW:1000.000KHz VBW:3000.000KHz SWT:Auto Detector : Peak</p>	 <p>Site : 03CH16-HY Condition : PEAK(UNIT) 3m 91200_1522 VERTICAL RBW:1000.000KHz VBW:3000.000KHz SWT:Auto Detector : Peak</p>
<p>Avg.</p>	 <p>Site : 03CH16-HY Condition : AVG_BE_54 3m 91200_1522 VERTICAL RBW:1000.000KHz VBW:0.010KHz SWT:Auto Detector : Peak</p>	<p>Left blank</p>

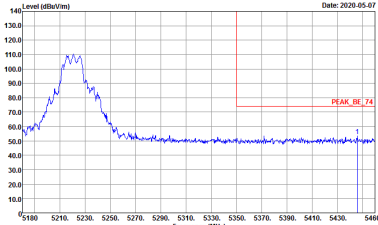
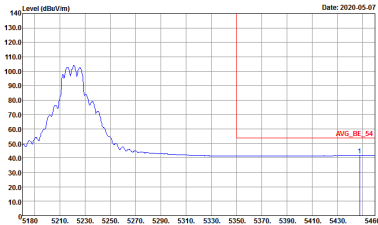

WIFI	Band 1 5150~5250MHz Band Edge @ 3m	
ANT	802.11a CH44 5220MHz - R	
4+3	Vertical	Fundamental
<p>Peak</p>	 <p>Site : 03CH16-FY Condition : PEAK_BE_74 3m 91200_1522 VERTICAL RBW:1000.000KHz VBW:3000.000KHz SWT:Auto Detector : Peak</p>	<p>Left blank</p>
<p>Avg.</p>	 <p>Site : 03CH16-FY Condition : AVG_BE_54 3m 91200_1522 VERTICAL RBW:1000.000KHz VBW:0.010KHz SWT:Auto Detector : Peak</p>	<p>Left blank</p>

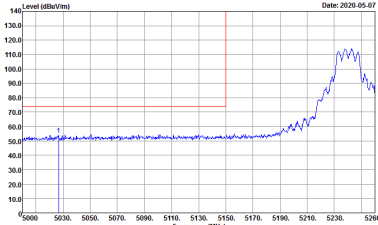
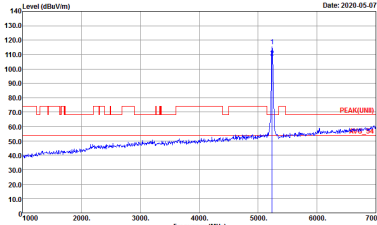
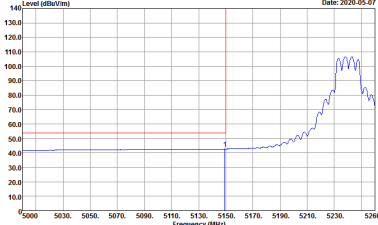

WIFI	Band 1 5150~5250MHz Band Edge @ 3m	
ANT	802.11a CH48 5240MHz - L	
4+3	Horizontal	Fundamental
<p>Peak</p>	 <p>Site : 03CH16-HY Condition : PEAK_BE_74 3m 91200_1522 HORIZONTAL RBW:1000.000KHz VBW:3000.000KHz SWT:Auto Detector : Peak</p>	 <p>Site : 03CH16-HY Condition : PEAK(UNIT) 3m 91200_1522 HORIZONTAL RBW:1000.000KHz VBW:3000.000KHz SWT:Auto Detector : Peak</p>
<p>Avg.</p>	 <p>Site : 03CH16-HY Condition : AVG_BE_54 3m 91200_1522 HORIZONTAL RBW:1000.000KHz VBW:0.010KHz SWT:Auto Detector : Peak</p>	<p>Left blank</p>

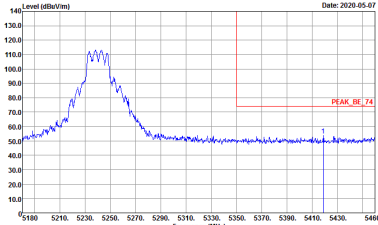
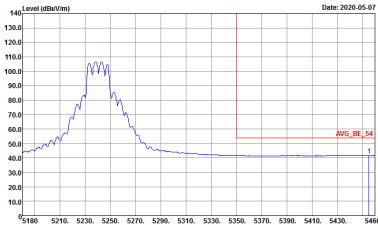

WIFI	Band 1 5150~5250MHz Band Edge @ 3m	
ANT	802.11a CH48 5240MHz - R	
4+3	Horizontal	Fundamental
<p>Peak</p>	 <p>Site : 03CH16-FY Condition : PEAK_BE_74 3m 91200_1522 HORIZONTAL RBW:1000.000KHz VBW:3000.000KHz SWT:Auto Detector : Peak</p>	<p>Left blank</p>
<p>Avg.</p>	 <p>Site : 03CH16-FY Condition : AVG_BE_54 3m 91200_1522 HORIZONTAL RBW:1000.000KHz VBW:0.010KHz SWT:Auto Detector : Peak</p>	<p>Left blank</p>

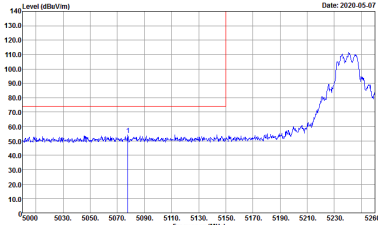
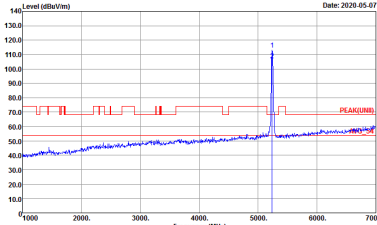
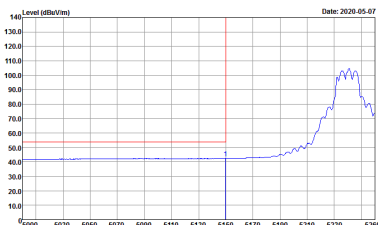

WIFI	Band 1 5150~5250MHz Band Edge @ 3m	
ANT	802.11a CH48 5240MHz - L	
4+3	Vertical	Fundamental
<p>Peak</p>	 <p>Site : 03CH16-HY Condition : PEAK_BE_74 3m 91200_1522 VERTICAL RBW:1000.000KHz VBW:3000.000KHz SWT:Auto Detector : Peak</p>	 <p>Site : 03CH16-HY Condition : PEAK(UNIT) 3m 91200_1522 VERTICAL RBW:1000.000KHz VBW:3000.000KHz SWT:Auto Detector : Peak</p>
<p>Avg.</p>	 <p>Site : 03CH16-HY Condition : AVG_BE_54 3m 91200_1522 VERTICAL RBW:1000.000KHz VBW:0.010KHz SWT:Auto Detector : Peak</p>	<p>Left blank</p>



WIFI	Band 1 5150~5250MHz Band Edge @ 3m	
ANT	802.11a CH48 5240MHz - R	
4+3	Vertical	Fundamental
Peak	<p>Site : 03CH16-FY Condition : PEAK_BE_74 3m 91200_1522 VERTICAL RBW:1000.000KHz VBW:3000.000KHz SWT:Auto Detector : Peak</p>	Left blank
Avg.	<p>Site : 03CH16-FY Condition : AVG_BE_54 3m 91200_1522 VERTICAL RBW:1000.000KHz VBW:0.010KHz SWT:Auto Detector : Peak</p>	Left blank

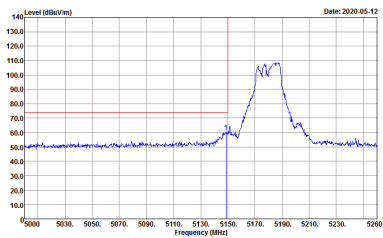
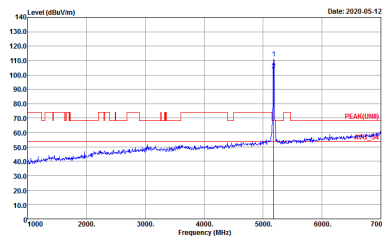
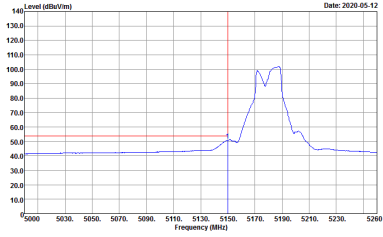

Band 1 5150~5250MHz
WIFI 802.11n HT20 (Band Edge @ 3m)

WIFI	Band 1 5150~5250MHz Band Edge @ 3m	
ANT	802.11n HT20 CH36 5180MHz	
4+3	Horizontal	Fundamental
Peak	 <p>Site : 03CH16-HY Condition : PEAK_BE_74 3m 91200_1522 HORIZONTAL RBW:1000.000KHz VBW:3000.000KHz SWT:Auto Detector : Peak</p>	 <p>Site : 03CH16-HY Condition : PEAK(LINII) 3m 91200_1522 HORIZONTAL RBW:1000.000KHz VBW:3000.000KHz SWT:Auto Detector : Peak</p>
Avg.	 <p>Site : 03CH16-HY Condition : AVG_BE_54 3m 91200_1522 HORIZONTAL RBW:1000.000KHz VBW:3000.000KHz SWT:Auto Detector : Peak</p>	Left blank

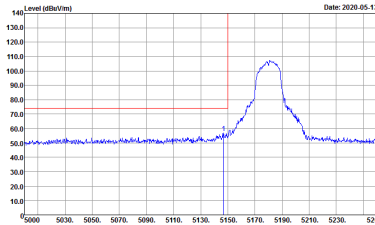
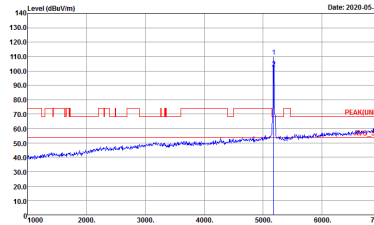
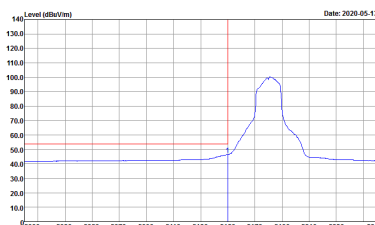

WIFI	Band 1 5150~5250MHz Band Edge @ 3m	
ANT	802.11n HT20 CH36 5180MHz	
4+3	Vertical	Fundamental
<p>Peak</p>	 <p>Site : 03CH16-HY Condition : PEAK_BE_74 3m 91200_1522 VERTICAL RBW:1000.000KHz VBW:3000.000KHz SWT:Auto Detector : Peak</p>	 <p>Site : 03CH16-HY Condition : PEAK(UNIT) 3m 91200_1522 VERTICAL RBW:1000.000KHz VBW:3000.000KHz SWT:Auto Detector : Peak</p>
<p>Avg.</p>	 <p>Site : 03CH16-HY Condition : AVG_BE_54 3m 91200_1522 VERTICAL RBW:1000.000KHz VBW:0.010KHz SWT:Auto Detector : Peak</p>	<p>Left blank</p>

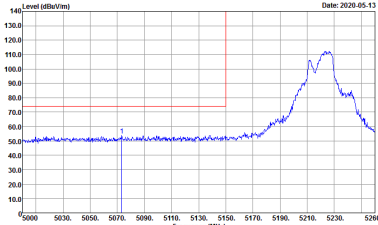
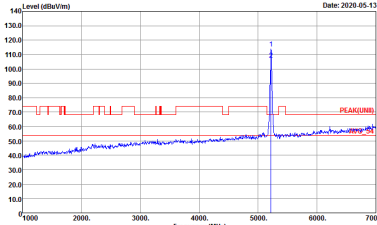
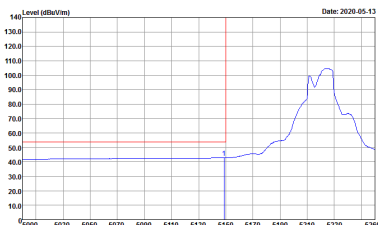

WIFI	Band 1 5150~5250MHz Band Edge @ 3m	
ANT	802.11n HT20 CH44 5220MHz - L	
4+3	Horizontal	Fundamental
<p>Peak</p>	 <p>Site : 03CH16-HY Condition : PEAK_BE_74 3m 91200_1522 HORIZONTAL RBW:1000.000KHz VBW:3000.000KHz SWT:Auto Detector : Peak</p>	 <p>Site : 03CH16-HY Condition : PEAK(UNIT) 3m 91200_1522 HORIZONTAL RBW:1000.000KHz VBW:3000.000KHz SWT:Auto Detector : Peak</p>
<p>Avg.</p>	 <p>Site : 03CH16-HY Condition : AVG_BE_54 3m 91200_1522 HORIZONTAL RBW:1000.000KHz VBW:0.010KHz SWT:Auto Detector : Peak</p>	<p>Left blank</p>

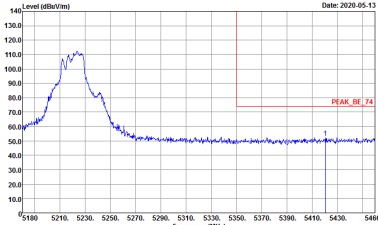
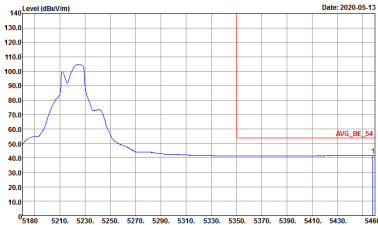

WIFI	Band 1 5150~5250MHz Band Edge @ 3m	
ANT	802.11n HT20 CH44 5220MHz - R	
4+3	Horizontal	Fundamental
<p>Peak</p>	 <p>Site : 03CH16-HY Condition : PEAK_BE_74 3m 91200_1522 HORIZONTAL RBW:1000.000KHz VBW:3000.000KHz SWT:Auto Detector : Peak</p>	<p>Left blank</p>
<p>Avg.</p>	 <p>Site : 03CH16-HY Condition : AVG_BE_54 3m 91200_1522 HORIZONTAL RBW:1000.000KHz VBW:0.010KHz SWT:Auto Detector : Peak</p>	<p>Left blank</p>

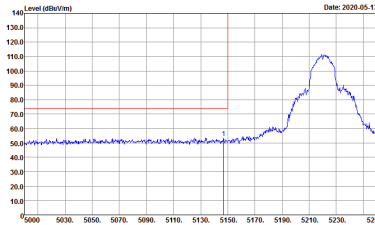
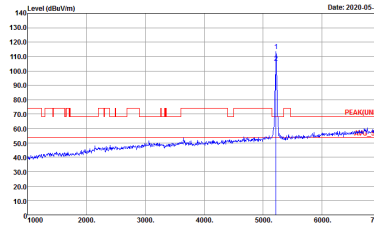
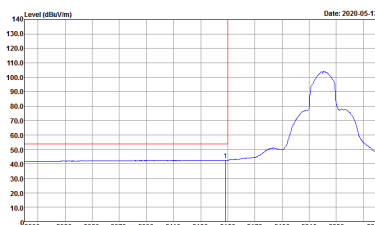

WIFI	Band 1 5150~5250MHz Band Edge @ 3m	
ANT	802.11n HT20 CH44 5220MHz - L	
4+3	Vertical	Fundamental
<p>Peak</p>	 <p>Site : 03CH16-HY Condition : PEAK_BE_74 3m 91200_1522 VERTICAL RBW:1000.000KHz VBW:3000.000KHz SWT:Auto Detector : Peak</p>	 <p>Site : 03CH16-HY Condition : PEAK(UNIT) 3m 91200_1522 VERTICAL RBW:1000.000KHz VBW:3000.000KHz SWT:Auto Detector : Peak</p>
<p>Avg.</p>	 <p>Site : 03CH16-HY Condition : AVG_BE_54 3m 91200_1522 VERTICAL RBW:1000.000KHz VBW:0.010KHz SWT:Auto Detector : Peak</p>	<p>Left blank</p>

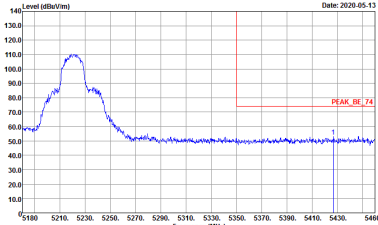
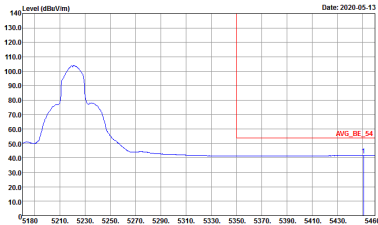

WIFI	Band 1 5150~5250MHz Band Edge @ 3m	
ANT	802.11n HT20 CH44 5220MHz - R	
4+3	Vertical	Fundamental
<p>Peak</p>	 <p>Site : 03CH16-FY Condition : PEAK_BE_74 3m 91200_1522 VERTICAL RBW:1000.000KHz VBW:3000.000KHz SWT:Auto Detector : Peak</p>	<p>Left blank</p>
<p>Avg.</p>	 <p>Site : 03CH16-FY Condition : AVG_BE_54 3m 91200_1522 VERTICAL RBW:1000.000KHz VBW:0.010KHz SWT:Auto Detector : Peak</p>	<p>Left blank</p>

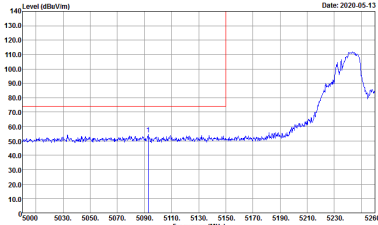
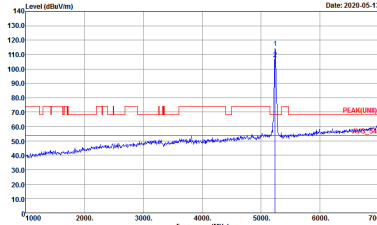
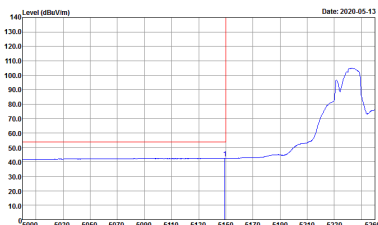

WIFI	Band 1 5150~5250MHz Band Edge @ 3m	
ANT	802.11n HT20 CH48 5240MHz - L	
4+3	Horizontal	Fundamental
<p>Peak</p>	 <p>Site : 03CH16-HY Condition : PEAK_BE_74 3m 91200_1522 HORIZONTAL RBW:1000.000KHz VBW:3000.000KHz SWT:Auto Detector : Peak</p>	 <p>Site : 03CH16-HY Condition : PEAK(UNIT) 3m 91200_1522 HORIZONTAL RBW:1000.000KHz VBW:3000.000KHz SWT:Auto Detector : Peak</p>
<p>Avg.</p>	 <p>Site : 03CH16-HY Condition : AVG_BE_54 3m 91200_1522 HORIZONTAL RBW:1000.000KHz VBW:0.010KHz SWT:Auto Detector : Peak</p>	<p>Left blank</p>



WIFI	Band 1 5150~5250MHz Band Edge @ 3m	
ANT	802.11n HT20 CH48 5240MHz - R	
4+3	Horizontal	Fundamental
<p>Peak</p>	<p>Site : 03CH16-FY Condition : PEAK_BE_74 3m 91200_1522 HORIZONTAL RBW:1000.000KHz VBW:3000.000KHz SWT:Auto Detector : Peak</p>	<p>Left blank</p>
<p>Avg.</p>	<p>Site : 03CH16-FY Condition : AVG_BE_54 3m 91200_1522 HORIZONTAL RBW:1000.000KHz VBW:0.010KHz SWT:Auto Detector : Peak</p>	<p>Left blank</p>

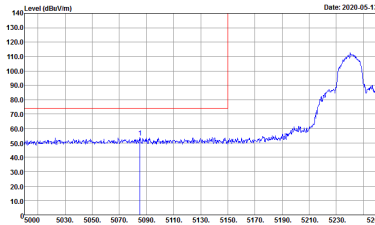
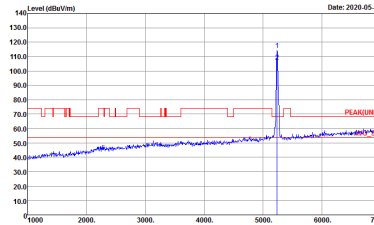
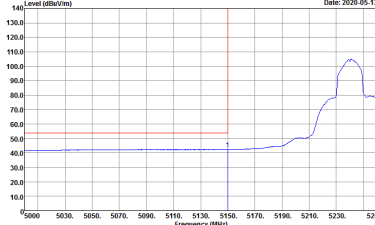

WIFI	Band 1 5150~5250MHz Band Edge @ 3m	
ANT	802.11n HT20 CH48 5240MHz - L	
4+3	Vertical	Fundamental
<p>Peak</p>	 <p>Site : 03CH16-HY Condition : PEAK_BE_74 3m 91200_1522 VERTICAL RBW:1000.000KHz VBW:3000.000KHz SWT:Auto Detector : Peak</p>	 <p>Site : 03CH16-HY Condition : PEAK(UNIT) 3m 91200_1522 VERTICAL RBW:1000.000KHz VBW:3000.000KHz SWT:Auto Detector : Peak</p>
<p>Avg.</p>	 <p>Site : 03CH16-HY Condition : AVG_BE_54 3m 91200_1522 VERTICAL RBW:1000.000KHz VBW:0.010KHz SWT:Auto Detector : Peak</p>	<p>Left blank</p>

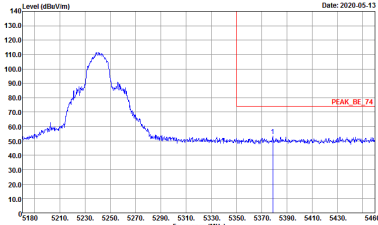
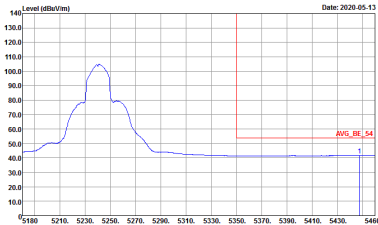

WIFI	Band 1 5150~5250MHz Band Edge @ 3m	
ANT	802.11n HT20 CH48 5240MHz - R	
4+3	Vertical	Fundamental
<p>Peak</p>	 <p>Site : 03CH16-FY Condition : PEAK_BE_74 3m 91200_1522 VERTICAL RBW:1000.000KHz VBW:3000.000KHz SWT:Auto Detector : Peak</p>	<p>Left blank</p>
<p>Avg.</p>	 <p>Site : 03CH16-FY Condition : AVG_BE_54 3m 91200_1522 VERTICAL RBW:1000.000KHz VBW:0.010KHz SWT:Auto Detector : Peak</p>	<p>Left blank</p>

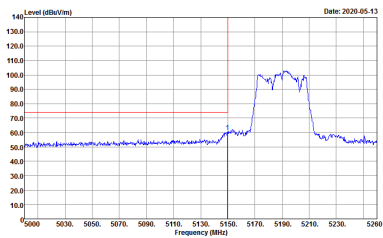
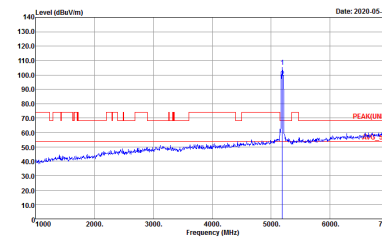
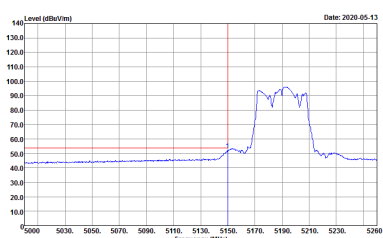

Band 1 5150~5250MHz
WIFI 802.11n HT40 (Band Edge @ 3m)

WIFI	Band 1 5150~5250MHz Band Edge @ 3m	
ANT	802.11n HT40 CH38 5190MHz - L	
4+3	Horizontal	Fundamental
Peak	 <p>Site : 03CH16-HY Condition : PEAK_BE_74 3m 91200_1522 HORIZONTAL RBW:1000.000kHz VBW:3000.000kHz SWT:Auto Detector : Peak</p>	 <p>Site : 03CH16-HY Condition : PEAK(LINII) 3m 91200_1522 HORIZONTAL RBW:1000.000kHz VBW:3000.000kHz SWT:Auto Detector : Peak</p>
Avg.	 <p>Site : 03CH16-HY Condition : AVG_BE_54 3m 91200_1522 HORIZONTAL RBW:1000.000kHz VBW:3.000kHz SWT:Auto Detector : Peak</p>	Left blank

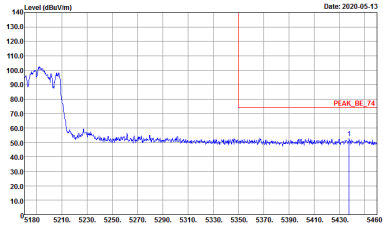
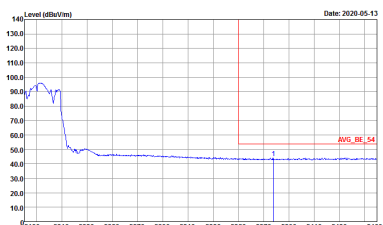

WIFI	Band 1 5150~5250MHz Band Edge @ 3m	
ANT	802.11n HT40 CH38 5190MHz - R	
4+3	Horizontal	Fundamental
<p>Peak</p>	 <p>Site : 03CH16-FY Condition : PEAK_BE_74 3m 91200_1522 HORIZONTAL RBW:1000.000KHz VBW:3000.000KHz SWT:Auto Detector : Peak</p>	<p>Left blank</p>
<p>Avg.</p>	 <p>Site : 03CH16-FY Condition : AVG_BE_54 3m 91200_1522 HORIZONTAL RBW:1000.000KHz VBW:3.000KHz SWT:Auto Detector : Peak</p>	<p>Left blank</p>

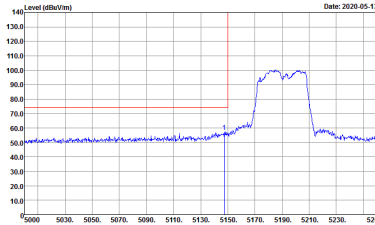
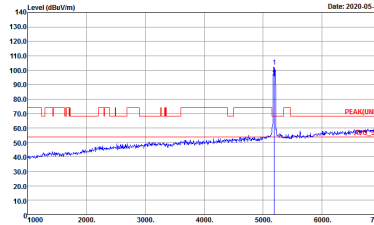
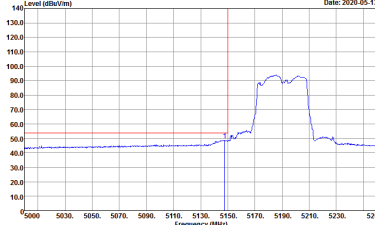

WIFI	Band 1 5150~5250MHz Band Edge @ 3m	
ANT	802.11n HT40 CH38 5190MHz - L	
4+3	Vertical	Fundamental
<p>Peak</p>	 <p>Site : 03CH16-HY Condition : PEAK_BE_74 3m 91200_1522 VERTICAL RBW:1000.000KHz VBW:3000.000KHz SWT:Auto Detector : Peak</p>	 <p>Site : 03CH16-HY Condition : PEAK(UNIT) 3m 91200_1522 VERTICAL RBW:1000.000KHz VBW:3000.000KHz SWT:Auto Detector : Peak</p>
<p>Avg.</p>	 <p>Site : 03CH16-HY Condition : AVG_BE_54 3m 91200_1522 VERTICAL RBW:1000.000KHz VBW:3.000KHz SWT:Auto Detector : Peak</p>	<p>Left blank</p>



WIFI	Band 1 5150~5250MHz Band Edge @ 3m	
ANT	802.11n HT40 CH38 5190MHz - R	
4+3	Vertical	Fundamental
Peak	<p>Site : 03CH16-FY Condition : PEAK_BE_74 3m 91200_1522 VERTICAL RBW:1000.000KHz VBW:3000.000KHz SWT:Auto Detector : Peak</p>	Left blank
Avg.	<p>Site : 03CH16-FY Condition : AVG_BE_54 3m 91200_1522 VERTICAL RBW:1000.000KHz VBW:3.000KHz SWT:Auto Detector : Peak</p>	Left blank

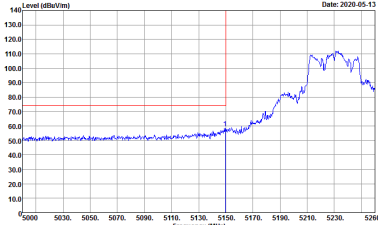
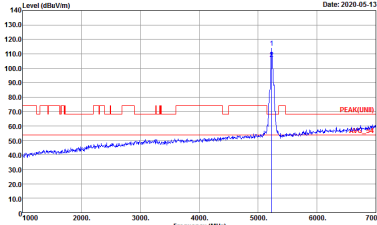
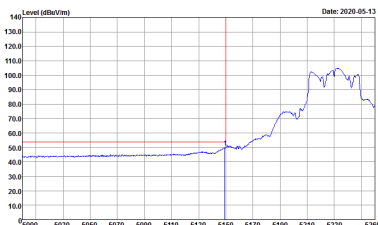

WIFI	Band 1 5150~5250MHz Band Edge @ 3m	
ANT	802.11n HT40 CH46 5230MHz - L	
4+3	Horizontal	Fundamental
<p>Peak</p>	 <p>Site : 03CH16-HY Condition : PEAK_BE_74 3m 91200_1522 HORIZONTAL RBW:1000.000KHz VBW:3000.000KHz SWT:Auto Detector : Peak</p>	 <p>Site : 03CH16-HY Condition : PEAK(UNIT) 3m 91200_1522 HORIZONTAL RBW:1000.000KHz VBW:3000.000KHz SWT:Auto Detector : Peak</p>
<p>Avg.</p>	 <p>Site : 03CH16-HY Condition : AVG_BE_54 3m 91200_1522 HORIZONTAL RBW:1000.000KHz VBW:3.000KHz SWT:Auto Detector : Peak</p>	<p>Left blank</p>

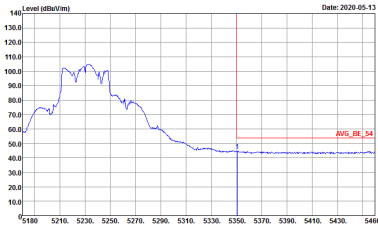

WIFI	Band 1 5150~5250MHz Band Edge @ 3m	
ANT	802.11n HT40 CH46 5230MHz - R	
4+3	Horizontal	Fundamental
<p>Peak</p>	 <p>Site : 03CH16-HY Condition : PEAK_BE_74 3m 91200_1522 HORIZONTAL RBW:1000.000KHz VBW:3000.000KHz SWT:Auto Detector : Peak</p>	<p>Left blank</p>
<p>Avg.</p>	 <p>Site : 03CH16-HY Condition : AVG_BE_54 3m 91200_1522 HORIZONTAL RBW:1000.000KHz VBW:3.000KHz SWT:Auto Detector : Peak</p>	<p>Left blank</p>

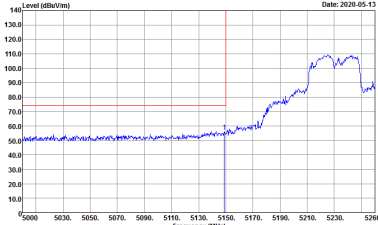
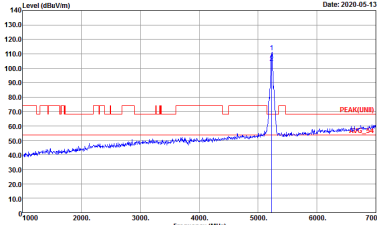
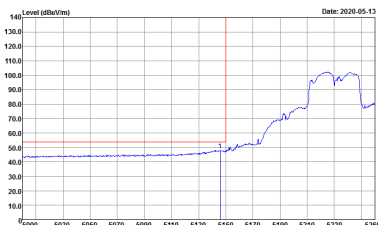

WIFI	Band 1 5150~5250MHz Band Edge @ 3m	
ANT	802.11n HT40 CH46 5230MHz - L	
4+3	Vertical	Fundamental
<p>Peak</p>	 <p>Site : 03CH16-HY Condition : PEAK_BE_74 3m 91200_1522 VERTICAL RBW:1000.000KHz VBW:3000.000KHz SWT:Auto Detector : Peak</p>	 <p>Site : 03CH16-HY Condition : PEAK(UNIT) 3m 91200_1522 VERTICAL RBW:1000.000KHz VBW:3000.000KHz SWT:Auto Detector : Peak</p>
<p>Avg.</p>	 <p>Site : 03CH16-HY Condition : AVG_BE_54 3m 91200_1522 VERTICAL RBW:1000.000KHz VBW:3000.000KHz SWT:Auto Detector : Peak</p>	<p>Left blank</p>

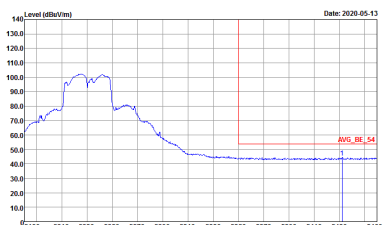

WIFI	Band 1 5150~5250MHz Band Edge @ 3m	
ANT	802.11n HT40 CH46 5230MHz - R	
4+3	Vertical	Fundamental
<p>Peak</p>	 <p>Site : 03CH16-FY Condition : PEAK_BE_74 3m 91200_1522 VERTICAL : RBW:1000.000KHz VBW:3000.000KHz SWT:Auto Detector : Peak</p>	<p>Left blank</p>
<p>Avg.</p>	 <p>Site : 03CH16-FY Condition : AVG_BE_54 3m 91200_1522 VERTICAL : RBW:1000.000KHz VBW:3.000KHz SWT:Auto Detector : Peak</p>	<p>Left blank</p>



Band 1 5150~5250MHz
WIFI 802.11ac VHT80 (Band Edge @ 3m)

Table with 2 columns (WIFI, ANT) and 2 rows (4+3, Peak, Avg.). It contains spectral analysis graphs for Horizontal and Fundamental signals, and a 'Left blank' label. Each graph shows Level (dBuV/m) vs Frequency (MHz) with technical parameters like Site, Condition, RBW, and Detector.

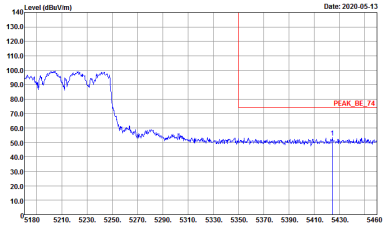
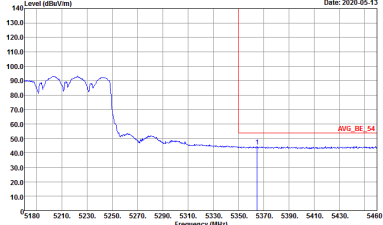

WIFI	Band 1 5150~5250MHz Band Edge @ 3m	
ANT	802.11ac VHT80 CH42 5210MHz - R	
4+3	Horizontal	Fundamental
<p>Peak</p>	 <p>Site : 03CH16-FY Condition : PEAK_BE_74 3m 91200_1522 HORIZONTAL RBW:1000.000KHz VBW:3000.000KHz SWT:Auto Detector : Peak</p>	<p>Left blank</p>
<p>Avg.</p>	 <p>Site : 03CH16-FY Condition : AVG_BE_54 3m 91200_1522 HORIZONTAL RBW:1000.000KHz VBW:3.000KHz SWT:Auto Detector : Peak</p>	<p>Left blank</p>

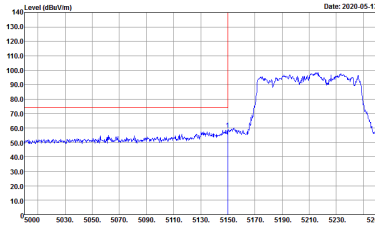
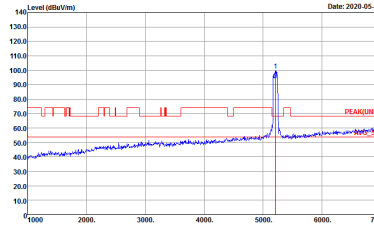
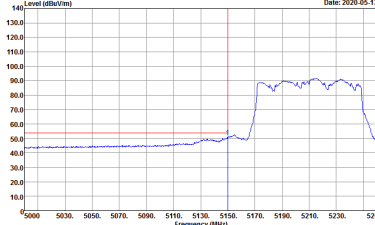

WIFI	Band 1 5150~5250MHz Band Edge @ 3m	
ANT	802.11ac VHT80 CH42 5210MHz - L	
4+3	Vertical	Fundamental
<p>Peak</p>	 <p>Site : 03CH16-HY Condition : PEAK_BE_74 3m 91200_1522 VERTICAL RBW:1000.000KHz VBW:3000.000KHz SWT:Auto Detector : Peak</p>	 <p>Site : 03CH16-HY Condition : PEAK(UNIT) 3m 91200_1522 VERTICAL RBW:1000.000KHz VBW:3000.000KHz SWT:Auto Detector : Peak</p>
<p>Avg.</p>	 <p>Site : 03CH16-HY Condition : AVG_BE_54 3m 91200_1522 VERTICAL RBW:1000.000KHz VBW:3.000KHz SWT:Auto Detector : Peak</p>	<p>Left blank</p>

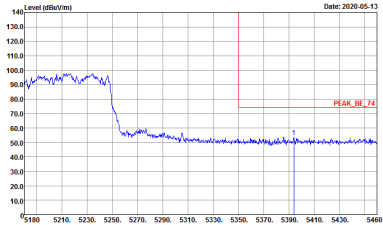
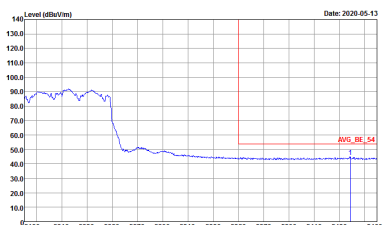

WIFI	Band 1 5150~5250MHz Band Edge @ 3m	
ANT	802.11ac VHT80 CH42 5210MHz - R	
4+3	Vertical	Fundamental
<p>Peak</p>	 <p>Site : 03CH16-FY Condition : PEAK_BE_74 3m 91200_1522 VERTICAL RBW:1000.000KHz VBW:3000.000KHz SWT:Auto Detector : Peak</p>	<p>Left blank</p>
<p>Avg.</p>	 <p>Site : 03CH16-FY Condition : AVG_BE_54 3m 91200_1522 VERTICAL RBW:1000.000KHz VBW:3.000KHz SWT:Auto Detector : Peak</p>	<p>Left blank</p>



Band 1 - 5150~5250MHz
WIFI 802.11a (Harmonic @ 3m)

WIFI	Band 1 5150~5250MHz Harmonic @ 3m	
ANT	802.11a CH36 5180MHz	
4+3	Horizontal	Vertical
Peak Avg.	<p>Site : 03CH16-HY Condition : PEAK(UNII) 3m 91200_1522 HORIZONTAL Detector : Peak</p>	<p>Site : 03CH16-HY Condition : PEAK(UNII) 3m 91200_1522 VERTICAL Detector : Peak</p>



WIFI	Band 1 5150~5250MHz Harmonic @ 3m	
ANT	802.11a CH44 5220MHz	
4+3	Horizontal	Vertical
Peak Avg.	<p>Site : 03CH16-HY Condition : PEAK(UNII) 3m 91200_1522 HORIZONTAL Detector : Peak</p>	<p>Site : 03CH16-HY Condition : PEAK(UNII) 3m 91200_1522 VERTICAL Detector : Peak</p>

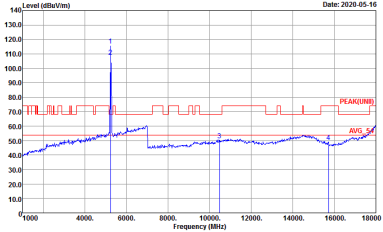
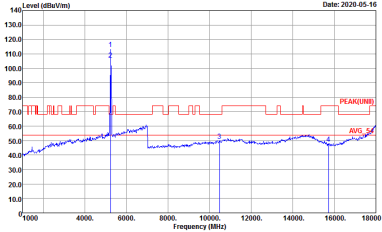

WIFI	Band 1 5150~5250MHz Harmonic @ 3m	
ANT	802.11a CH48 5240MHz	
4+3	Horizontal	Vertical
<p>Peak</p> <p>Avg.</p>	 <p>Site : 03CH16-HY Condition : PEAK(UNII) 3m 91200_1522 HORIZONTAL Detector : Peak</p>	 <p>Site : 03CH16-HY Condition : PEAK(UNII) 3m 91200_1522 VERTICAL Detector : Peak</p>



Band 1 5150~5250MHz
WIFI 802.11n HT20 (Harmonic @ 3m)

WIFI	Band 1 5150~5250MHz Harmonic @ 3m	
ANT	802.11n HT20 CH36 5180MHz	
4+3	Horizontal	Vertical
Peak Avg.	<p>Site : 03CH16-HY Condition : PEAK(UNII) 3m 91200_1522 HORIZONTAL Detector : Peak</p>	<p>Site : 03CH16-HY Condition : PEAK(UNII) 3m 91200_1522 VERTICAL Detector : Peak</p>



WIFI	Band 1 5150~5250MHz Harmonic @ 3m	
ANT	802.11n HT20 CH44 5220MHz	
4+3	Horizontal	Vertical
Peak Avg.	<p>Site : 03CH16-HY Condition : PEAK(UNII) 3m 91200_1522 HORIZONTAL Detector : Peak</p>	<p>Site : 03CH16-HY Condition : PEAK(UNII) 3m 91200_1522 VERTICAL Detector : Peak</p>



WIFI	Band 1 5150~5250MHz Harmonic @ 3m	
ANT	802.11n HT20 CH48 5240MHz	
4+3	Horizontal	Vertical
Peak Avg.	<p>Site : 03CH16-HY Condition : PEAK(UNII) 3m 91200_1522 HORIZONTAL Detector : Peak</p>	<p>Site : 03CH16-HY Condition : PEAK(UNII) 3m 91200_1522 VERTICAL Detector : Peak</p>



**Band 1 5150~5250MHz
WIFI 802.11n HT40 (Harmonic @ 3m)**

WIFI	Band 1 5150~5250MHz Harmonic @ 3m	
ANT	802.11n HT40 CH38 5190MHz	
4+3	Horizontal	Vertical
Peak Avg.	<p>Site : 03CH16-HY Condition : PEAK(UNII) 3m 9120D_1522 HORIZONTAL Detector : Peak</p>	<p>Site : 03CH16-HY Condition : PEAK(UNII) 3m 9120D_1522 VERTICAL Detector : Peak</p>



WIFI	Band 1 5150~5250MHz Harmonic @ 3m	
ANT	802.11n HT40 CH46 5230MHz	
4+3	Horizontal	Vertical
Peak Avg.	<p>Site : 03CH16-HY Condition : PEAK(UNIT) 3m 91200_1522 HORIZONTAL Detector : Peak</p>	<p>Site : 03CH16-HY Condition : PEAK(UNIT) 3m 91200_1522 VERTICAL Detector : Peak</p>



**Band 1 5150~5250MHz
WIFI 802.11ac VHT80 (Harmonic @ 3m)**

WIFI	Band 1 5150~5250MHz Harmonic @ 3m	
ANT	802.11ac VHT80 CH42 5210MHz	
4+3	Horizontal	Vertical
Peak Avg.	<p>Site : 03CH16-HY Condition : PEAK(UNII) 3m 91200_1522 HORIZONTAL Detector : Peak</p>	<p>Site : 03CH16-HY Condition : PEAK(UNII) 3m 91200_1522 VERTICAL Detector : Peak</p>

Band 2 - 5250~5350MHz
WIFI 802.11a (Band Edge @ 3m)

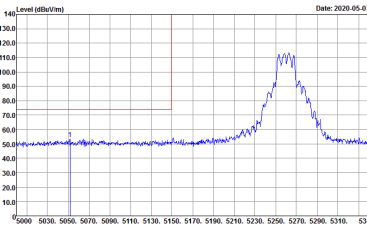
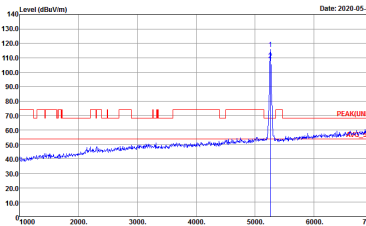
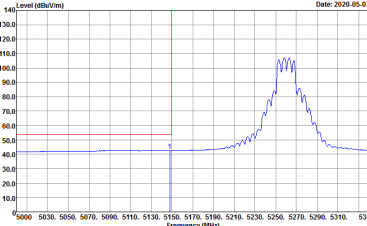
WIFI	Band 2 5250~5350MHz Band Edge @ 3m	
ANT	802.11a CH52 5260MHz - L	
4+3	Horizontal	Fundamental
<p>Peak</p>	 <p>Site : 03CH16-HY Condition : PEAK_BE_74 3m 91200_1522 HORIZONTAL : RBW:1000.000KHz VBW:3000.000KHz SWT:Auto Detector : Peak</p>	 <p>Site : 03CH16-HY Condition : PEAK(UNIT) 3m 91200_1522 HORIZONTAL : RBW:1000.000KHz VBW:3000.000KHz SWT:Auto Detector : Peak</p>
<p>Avg.</p>	 <p>Site : 03CH16-HY Condition : AVG_BE_54 3m 91200_1522 HORIZONTAL : RBW:1000.000KHz VBW:0.010KHz SWT:Auto Detector : Peak</p>	<p>Left blank</p>



WIFI	Band 2 5250~5350MHz Band Edge @ 3m	
ANT	802.11a CH52 5260MHz - R	
4+3	Horizontal	Fundamental
<p>Peak</p>	<p>Site : 03CH16-HY Condition : PEAK_BE_74 3m 91200_1522 HORIZONTAL RBW:1000.000KHz VBW:3000.000KHz SWT:Auto Detector : Peak</p>	<p>Left blank</p>
<p>Avg.</p>	<p>Site : 03CH16-HY Condition : AVG_BE_54 3m 91200_1522 HORIZONTAL RBW:1000.000KHz VBW:0.010KHz SWT:Auto Detector : Peak</p>	<p>Left blank</p>

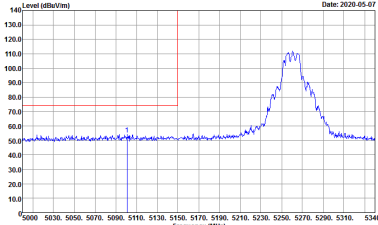
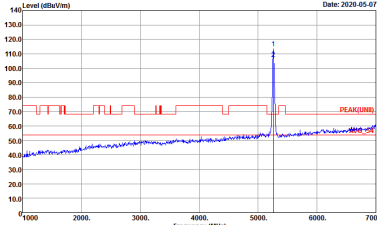
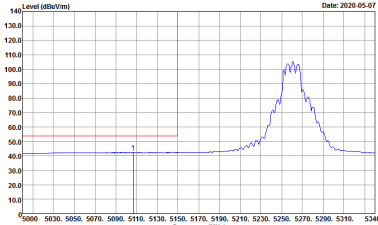

WIFI	Band 2 5250~5350MHz Band Edge @ 3m	
ANT	802.11a CH52 5260MHz - L	
4+3	Vertical	Fundamental
<p>Peak</p>	 <p>Site : 03CH16-HY Condition : PEAK_BE_74 3m 91200_1522 VERTICAL RBW:1000.000KHz VBW:3000.000KHz SWT:Auto Detector : Peak</p>	 <p>Site : 03CH16-HY Condition : PEAK(UNIT) 3m 91200_1522 VERTICAL RBW:1000.000KHz VBW:3000.000KHz SWT:Auto Detector : Peak</p>
<p>Avg.</p>	 <p>Site : 03CH16-HY Condition : AVG_BE_54 3m 91200_1522 VERTICAL RBW:1000.000KHz VBW:0.010KHz SWT:Auto Detector : Peak</p>	<p>Left blank</p>



WIFI	Band 2 5250~5350MHz Band Edge @ 3m	
ANT	802.11a CH52 5260MHz - R	
4+3	Vertical	Fundamental
<p>Peak</p>	<p>Site : 03CH16-#FY Condition : PEAK_BE_74 3m 91200_1522 VERTICAL RBW:1000.000KHz VBW:3000.000KHz SWT:Auto Detector : Peak</p>	<p>Left blank</p>
<p>Avg.</p>	<p>Site : 03CH16-#FY Condition : AVG_BE_54 3m 91200_1522 VERTICAL RBW:1000.000KHz VBW:0.010KHz SWT:Auto Detector : Peak</p>	<p>Left blank</p>

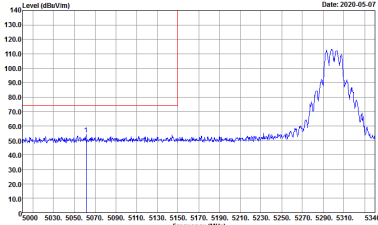
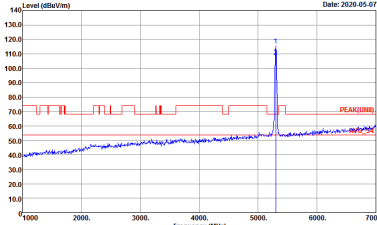
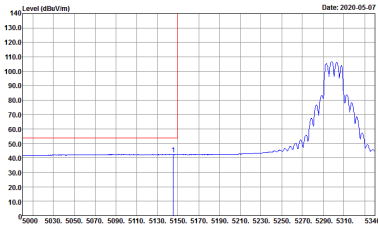

WIFI	Band 2 5250~5350MHz Band Edge @ 3m	
ANT	802.11a CH60 5300MHz - L	
4+3	Horizontal	Fundamental
<p>Peak</p>	 <p>Site : 03CH16-HY Condition : PEAK_BE_74 3m 91200_1522 HORIZONTAL RBW:1000.000KHz VBW:3000.000KHz SWT:Auto Detector : Peak</p>	 <p>Site : 03CH16-HY Condition : PEAK(UNIT) 3m 91200_1522 HORIZONTAL RBW:1000.000KHz VBW:3000.000KHz SWT:Auto Detector : Peak</p>
<p>Avg.</p>	 <p>Site : 03CH16-HY Condition : AVG_BE_54 3m 91200_1522 HORIZONTAL RBW:1000.000KHz VBW:0.010KHz SWT:Auto Detector : Peak</p>	<p>Left blank</p>



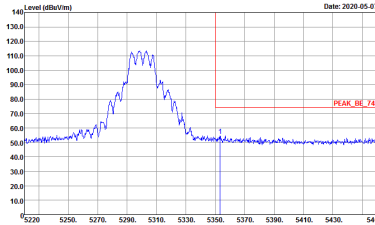
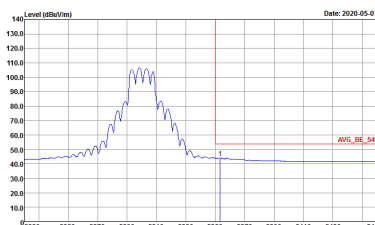

WIFI	Band 2 5250~5350MHz Band Edge @ 3m	
ANT	802.11a CH60 5300MHz - R	
4+3	Horizontal	Fundamental
<p>Peak</p>	 <p>Site : 03CH16-HY Condition : PEAK_BE_74 3m 91200_1522 HORIZONTAL RBW:1000.000KHz VBW:3000.000KHz SWT:Auto Detector : Peak</p>	<p>Left blank</p>
<p>Avg.</p>	 <p>Site : 03CH16-HY Condition : AVG_BE_54 3m 91200_1522 HORIZONTAL RBW:1000.000KHz VBW:0.010KHz SWT:Auto Detector : Peak</p>	<p>Left blank</p>

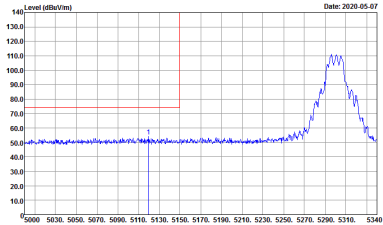
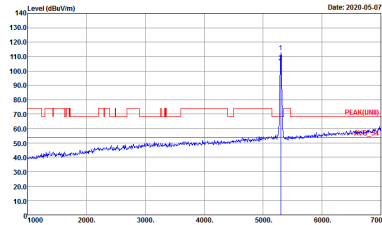
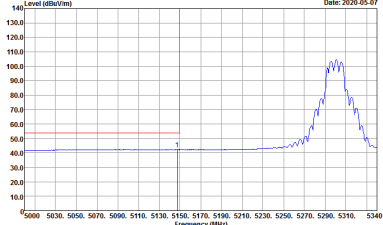

WIFI	Band 2 5250~5350MHz Band Edge @ 3m	
ANT	802.11a CH60 5300MHz - L	
4+3	Vertical	Fundamental
<p>Peak</p>	 <p>Site : 03CH16-HY Condition : PEAK_BE_74 3m 91200_1522 VERTICAL RBW:1000.000KHz VBW:3000.000KHz SWT:Auto Detector : Peak</p>	 <p>Site : 03CH16-HY Condition : PEAK(UNIT) 3m 91200_1522 VERTICAL RBW:1000.000KHz VBW:3000.000KHz SWT:Auto Detector : Peak</p>
<p>Avg.</p>	 <p>Site : 03CH16-HY Condition : AVG_BE_54 3m 91200_1522 VERTICAL RBW:1000.000KHz VBW:0.010KHz SWT:Auto Detector : Peak</p>	<p>Left blank</p>

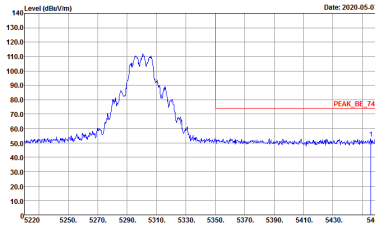

WIFI	Band 2 5250~5350MHz Band Edge @ 3m	
ANT	802.11a CH60 5300MHz - R	
4+3	Vertical	Fundamental
<p>Peak</p>	 <p>Site : 03CH16-FY Condition : PEAK_BE_74 3m 91200_1522 VERTICAL RBW:1000.000KHz VBW:3000.000KHz SWT:Auto Detector : Peak</p>	<p>Left blank</p>
<p>Avg.</p>	 <p>Site : 03CH16-FY Condition : AVG_BE_54 3m 91200_1522 VERTICAL RBW:1000.000KHz VBW:0.010KHz SWT:Auto Detector : Peak</p>	<p>Left blank</p>

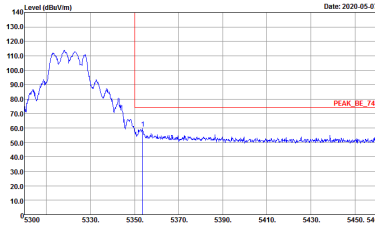
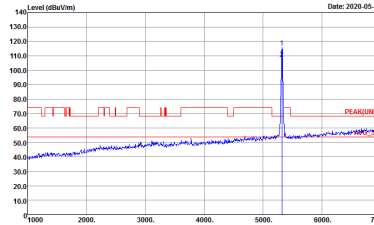
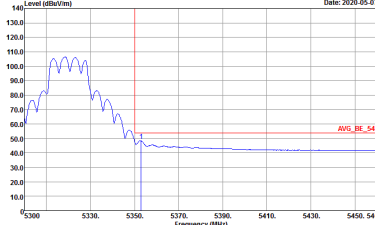

WIFI	Band 2 5250~5350MHz Band Edge @ 3m	
ANT	802.11a CH64 5320MHz	
4+3	Horizontal	Fundamental
<p>Peak</p>	 <p>Site : 03CH16-HY Condition : PEAK_BE_74 3m 91200_1522 HORIZONTAL RBW:1000.000KHz VBW:3000.000KHz SWT:Auto Detector : Peak</p>	 <p>Site : 03CH16-HY Condition : PEAK(UNIT) 3m 91200_1522 HORIZONTAL RBW:1000.000KHz VBW:3000.000KHz SWT:Auto Detector : Peak</p>
<p>Avg.</p>	 <p>Site : 03CH16-HY Condition : AVG_BE_54 3m 91200_1522 HORIZONTAL RBW:1000.000KHz VBW:0.010KHz SWT:Auto Detector : Peak</p>	<p>Left blank</p>

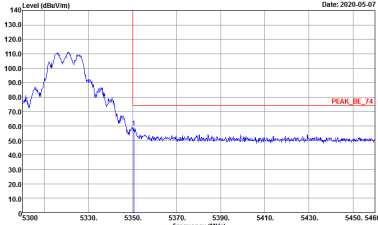
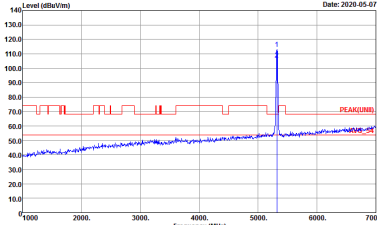
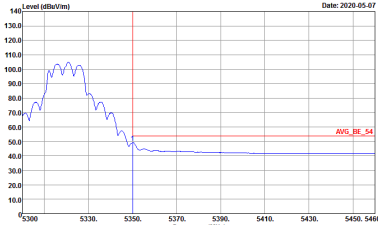

WIFI	Band 2 5250~5350MHz Band Edge @ 3m	
ANT	802.11a CH64 5320MHz	
4+3	Vertical	Fundamental
<p>Peak</p>	 <p>Site : 03CH16-HY Condition : PEAK_BE_74 3m 91200_1522 VERTICAL RBW:1000.000KHz VBW:3000.000KHz SWT:Auto Detector : Peak</p>	 <p>Site : 03CH16-HY Condition : PEAK(UNIT) 3m 91200_1522 VERTICAL RBW:1000.000KHz VBW:3000.000KHz SWT:Auto Detector : Peak</p>
<p>Avg.</p>	 <p>Site : 03CH16-HY Condition : AVG_BE_54 3m 91200_1522 VERTICAL RBW:1000.000KHz VBW:0.010KHz SWT:Auto Detector : Peak</p>	<p>Left blank</p>



Band 2 5250~5350MHz
WIFI 802.11n HT20 (Band Edge @ 3m)

WIFI	Band 2 5250~5350MHz Band Edge @ 3m	
ANT	802.11n HT20 CH52 5260MHz - L	
4+3	Horizontal	Fundamental
Peak	<p>Site : 03CH16-HY Condition : PEAK_BE_74 3m 91200_1522 HORIZONTAL RBW:1000.000KHz VBW:3000.000KHz SWT:Auto Detector : Peak</p>	<p>Site : 03CH16-HY Condition : PEAK(LINII) 3m 91200_1522 HORIZONTAL RBW:1000.000KHz VBW:3000.000KHz SWT:Auto Detector : Peak</p>
Avg.	<p>Site : 03CH16-HY Condition : AVG_BE_54 3m 91200_1522 HORIZONTAL RBW:1000.000KHz VBW:3000.000KHz SWT:Auto Detector : Peak</p>	Left blank

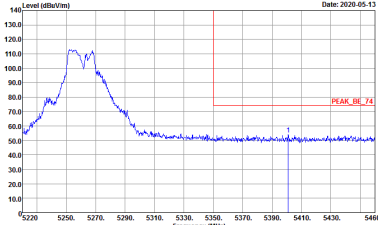
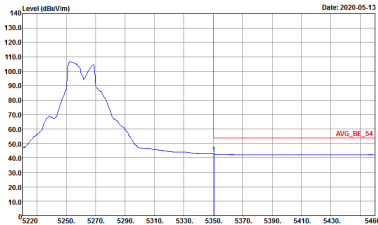

WIFI	Band 2 5250~5350MHz Band Edge @ 3m	
ANT	802.11n HT20 CH52 5260MHz - R	
4+3	Horizontal	Fundamental
<p>Peak</p>	 <p>Site : 03CH16-HY Condition : PEAK_BE_74 3m 91200_1522 HORIZONTAL RBW:1000.000KHz VBW:3000.000KHz SWT:Auto Detector : Peak</p>	<p>Left blank</p>
<p>Avg.</p>	 <p>Site : 03CH16-HY Condition : AVG_BE_54 3m 91200_1522 HORIZONTAL RBW:1000.000KHz VBW:0.010KHz SWT:Auto Detector : Peak</p>	<p>Left blank</p>

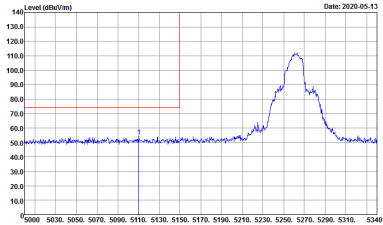
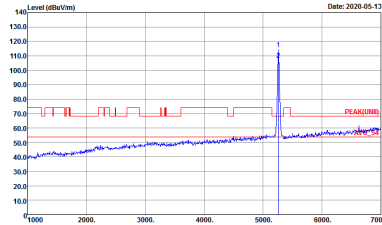
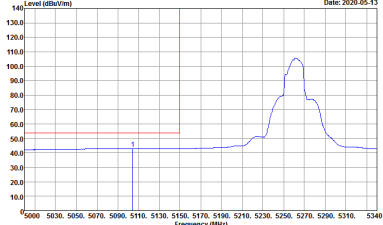

WIFI	Band 2 5250~5350MHz Band Edge @ 3m	
ANT	802.11n HT20 CH52 5260MHz - L	
4+3	Vertical	Fundamental
<p>Peak</p>	 <p>Site : 03CH16-11Y Condition : PEAK_BE_74 3m 91200_1522 VERTICAL RBW:1000.000KHz VBW:3000.000KHz SWT:Auto Detector : Peak</p>	 <p>Site : 03CH16-11Y Condition : PEAK(UNIT) 3m 91200_1522 VERTICAL RBW:1000.000KHz VBW:3000.000KHz SWT:Auto Detector : Peak</p>
<p>Avg.</p>	 <p>Site : 03CH16-11Y Condition : AVG_BE_54 3m 91200_1522 VERTICAL RBW:1000.000KHz VBW:0.010KHz SWT:Auto Detector : Peak</p>	<p>Left blank</p>

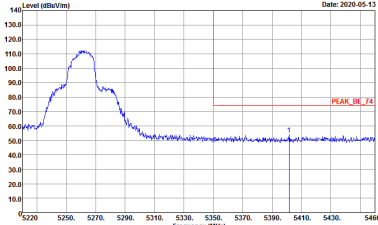
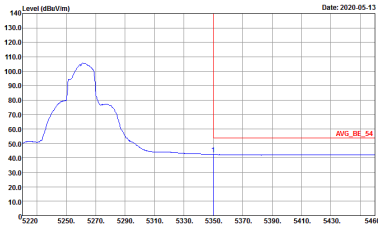

WIFI	Band 2 5250~5350MHz Band Edge @ 3m	
ANT	802.11n HT20 CH52 5260MHz - R	
4+3	Vertical	Fundamental
<p>Peak</p>	 <p>Site : 03CH16-FY Condition : PEAK_BE_74 3m 91200_1522 VERTICAL RBW:1000.000KHz VBW:3000.000KHz SWT:Auto Detector : Peak</p>	<p>Left blank</p>
<p>Avg.</p>	 <p>Site : 03CH16-FY Condition : AVG_BE_54 3m 91200_1522 VERTICAL RBW:1000.000KHz VBW:0.010KHz SWT:Auto Detector : Peak</p>	<p>Left blank</p>

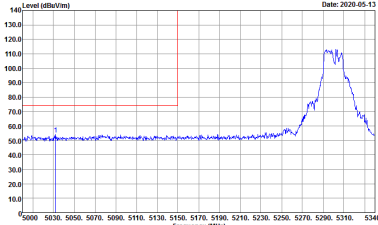
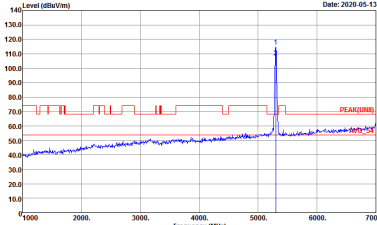
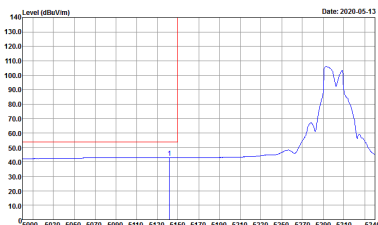

WIFI	Band 2 5250~5350MHz Band Edge @ 3m	
ANT	802.11n HT20 CH60 5300MHz - L	
4+3	Horizontal	Fundamental
<p>Peak</p>	 <p>Site : 03CH16-HY Condition : PEAK_BE_74 3m 91200_1522 HORIZONTAL RBW:1000.000KHz VBW:3000.000KHz SWT:Auto Detector : Peak</p>	 <p>Site : 03CH16-HY Condition : PEAK(UNIT) 3m 91200_1522 HORIZONTAL RBW:1000.000KHz VBW:3000.000KHz SWT:Auto Detector : Peak</p>
<p>Avg.</p>	 <p>Site : 03CH16-HY Condition : AVG_BE_54 3m 91200_1522 HORIZONTAL RBW:1000.000KHz VBW:0.010KHz SWT:Auto Detector : Peak</p>	<p>Left blank</p>

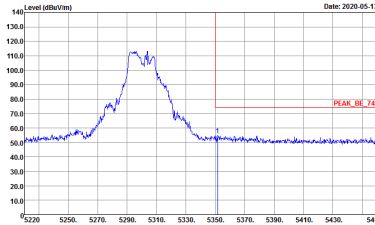
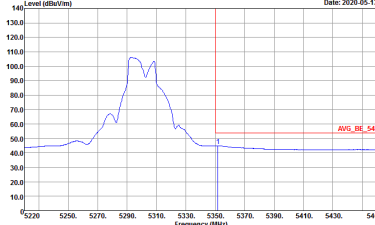

WIFI	Band 2 5250~5350MHz Band Edge @ 3m	
ANT	802.11n HT20 CH60 5300MHz - R	
4+3	Horizontal	Vertical
<p>Peak</p>	 <p>Site : 03CH16-HY Condition : PEAK_BE_74 3m 91200_1522 HORIZONTAL RBW:1000.000KHz VBW:3000.000KHz SWT:Auto Detector : Peak</p>	<p>Left blank</p>
<p>Avg.</p>	 <p>Site : 03CH16-HY Condition : AVG_BE_54 3m 91200_1522 HORIZONTAL RBW:1000.000KHz VBW:0.010KHz SWT:Auto Detector : Peak</p>	<p>Left blank</p>

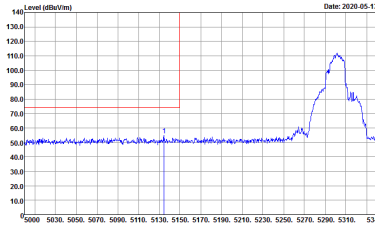
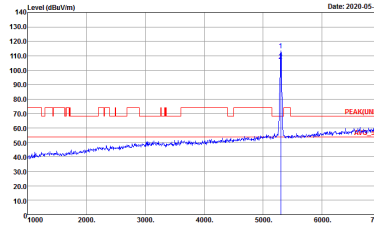
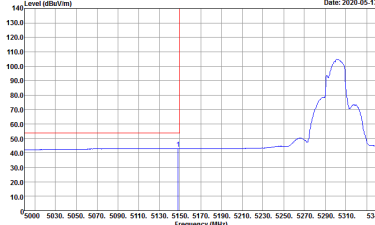

WIFI	Band 2 5250~5350MHz Band Edge @ 3m	
ANT	802.11n HT20 CH60 5300MHz - L	
4+3	Vertical	Fundamental
<p>Peak</p>	 <p>Site : 03CH16-HY Condition : PEAK_BE_74 3m 91200_1522 VERTICAL RBW:1000.000KHz VBW:3000.000KHz SWT:Auto Detector : Peak</p>	 <p>Site : 03CH16-HY Condition : PEAK(UNIT) 3m 91200_1522 VERTICAL RBW:1000.000KHz VBW:3000.000KHz SWT:Auto Detector : Peak</p>
<p>Avg.</p>	 <p>Site : 03CH16-HY Condition : AVG_BE_54 3m 91200_1522 VERTICAL RBW:1000.000KHz VBW:0.010KHz SWT:Auto Detector : Peak</p>	<p>Left blank</p>

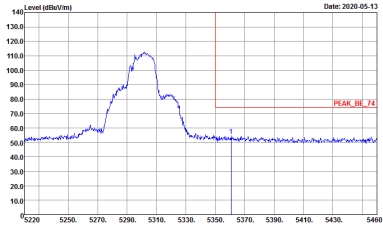
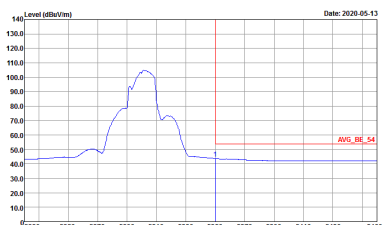

WIFI	Band 2 5250~5350MHz Band Edge @ 3m	
ANT	802.11n HT20 CH60 5300MHz - R	
4+3	Vertical	Fundamental
<p>Peak</p>	 <p>Site : 03CH16-HY Condition : PEAK_BE_74 3m 91200_1522 VERTICAL RBW:1000.000KHz VBW:3000.000KHz SWT:Auto Detector : Peak</p>	<p>Left blank</p>
<p>Avg.</p>	 <p>Site : 03CH16-HY Condition : AVG_BE_54 3m 91200_1522 VERTICAL RBW:1000.000KHz VBW:0.010KHz SWT:Auto Detector : Peak</p>	<p>Left blank</p>

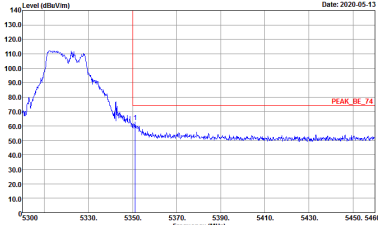
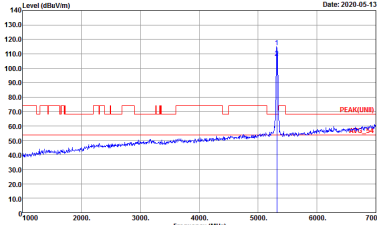
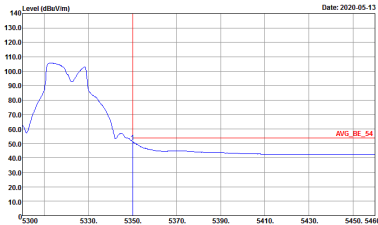

WIFI	Band 2 5250~5350MHz Band Edge @ 3m	
ANT	802.11n HT20 CH64 5320MHz	
4+3	Horizontal	Fundamental
<p>Peak</p>	 <p>Date: 2020-05-13</p> <p>Site : 03CH16-HY Condition : PEAK_BE_74 3m 91200_1522 HORIZONTAL RBW:1000.000KHz VBW:3000.000KHz SWT:Auto Detector : Peak</p>	 <p>Date: 2020-05-13</p> <p>Site : 03CH16-HY Condition : PEAK(UNIT) 3m 91200_1522 HORIZONTAL RBW:1000.000KHz VBW:3000.000KHz SWT:Auto Detector : Peak</p>
<p>Avg.</p>	 <p>Date: 2020-05-13</p> <p>Site : 03CH16-HY Condition : AVG_BE_54 3m 91200_1522 HORIZONTAL RBW:1000.000KHz VBW:0.010KHz SWT:Auto Detector : Peak</p>	<p>Left blank</p>

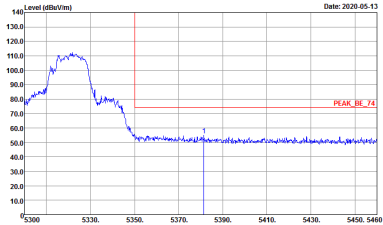
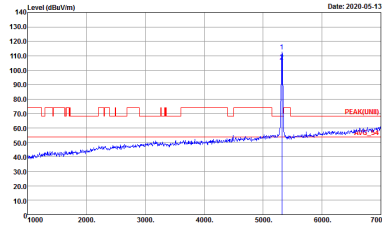
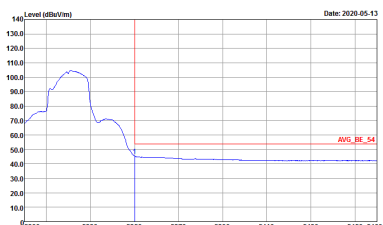

WIFI	Band 2 5250~5350MHz Band Edge @ 3m	
ANT	802.11n HT20 CH64 5320MHz	
4+3	Vertical	Fundamental
<p>Peak</p>	 <p>Site : 03CH16-HY Condition : PEAK_BE_74 3m 91200_1522 VERTICAL RBW:1000.000KHz VBW:3000.000KHz SWT:Auto Detector : Peak</p>	 <p>Site : 03CH16-HY Condition : PEAK(UNIT) 3m 91200_1522 VERTICAL RBW:1000.000KHz VBW:3000.000KHz SWT:Auto Detector : Peak</p>
<p>Avg.</p>	 <p>Site : 03CH16-HY Condition : AVG_BE_54 3m 91200_1522 VERTICAL RBW:1000.000KHz VBW:0.010KHz SWT:Auto Detector : Peak</p>	<p>Left blank</p>

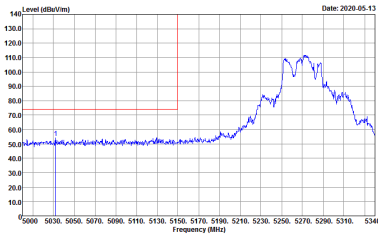
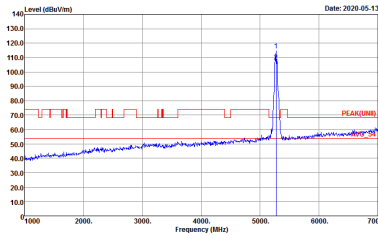
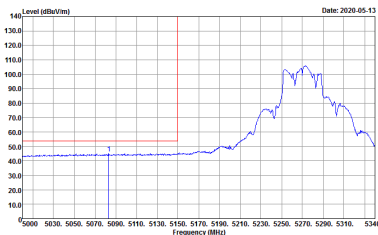

Band 2 5250~5350MHz
WIFI 802.11n HT40 (Band Edge @ 3m)

WIFI	Band 2 5250~5350MHz Band Edge @ 3m	
ANT	802.11n HT40 CH54 5270 - L	
4+3	Horizontal	Fundamental
<p>Peak</p>	 <p>Site : 03CH16-HY Condition : PEAK_BE_74 3m 91200_1522 HORIZONTAL RBW:1000.000KHz VBW:3000.000KHz SWT:Auto Detector : Peak</p>	 <p>Site : 03CH16-HY Condition : PEAK(LINII) 3m 91200_1522 HORIZONTAL RBW:1000.000KHz VBW:3000.000KHz SWT:Auto Detector : Peak</p>
<p>Avg.</p>	 <p>Site : 03CH16-HY Condition : AVG_BE_54 3m 91200_1522 HORIZONTAL RBW:1000.000KHz VBW:3.000KHz SWT:Auto Detector : Peak</p>	<p align="center">Left blank</p>

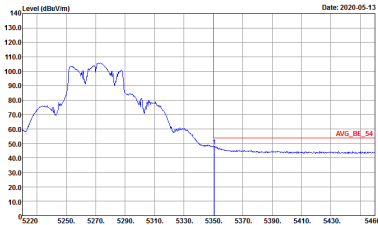

WIFI	Band 2 5250~5350MHz Band Edge @ 3m	
ANT	802.11n HT40 CH54 5270 - R	
4+3	Horizontal	Fundamental
<p>Peak</p>	 <p>Site : 03CH16-HY Condition : PEAK_BE_74 3m 91200_1522 HORIZONTAL RBW:1000.000KHz VBW:3000.000KHz SWT:Auto Detector : Peak</p>	<p>Left blank</p>
<p>Avg.</p>	 <p>Site : 03CH16-HY Condition : AVG_BE_54 3m 91200_1522 HORIZONTAL RBW:1000.000KHz VBW:3.000KHz SWT:Auto Detector : Peak</p>	<p>Left blank</p>

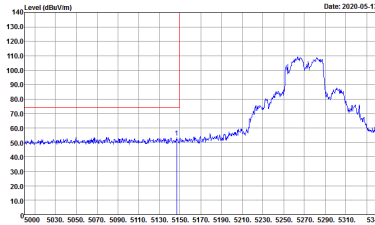
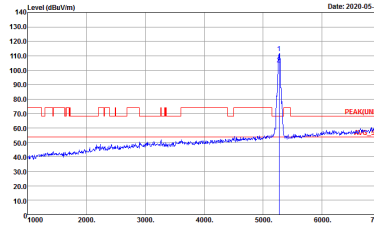
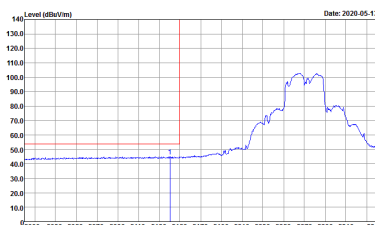

WIFI	Band 2 5250~5350MHz Band Edge @ 3m	
ANT	802.11n HT40 CH54 5270 - L	
4+3	Vertical	Vertical
Peak	 <p>Site : 03CH16-1FY Condition : PEAK_BE_74 3m 91200_1522 VERTICAL RBW:1000.000KHz VBW:3000.000KHz SWT:Auto Detector : Peak</p>	 <p>Site : 03CH16-1FY Condition : PEAK(UNIT) 3m 91200_1522 VERTICAL RBW:1000.000KHz VBW:3000.000KHz SWT:Auto Detector : Peak</p>
Avg.	 <p>Site : 03CH16-1FY Condition : AVG_BE_54 3m 91200_1522 VERTICAL RBW:1000.000KHz VBW:3.000KHz SWT:Auto Detector : Peak</p>	Left blank



WIFI	Band 2 5250~5350MHz Band Edge @ 3m	
ANT	802.11n HT40 CH54 5270 - R	
4+3	Vertical	Vertical
Peak	<p>Site : 03CH16-HY Condition : PEAK_BE_74 3m 91200_1522 VERTICAL RBW:1000.000KHz VBW:3000.000KHz SWT:Auto Detector : Peak</p>	Left blank
Avg.	<p>Site : 03CH16-HY Condition : AVG_BE_54 3m 91200_1522 VERTICAL RBW:1000.000KHz VBW:3.000KHz SWT:Auto Detector : Peak</p>	Left blank

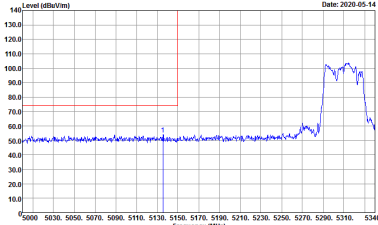
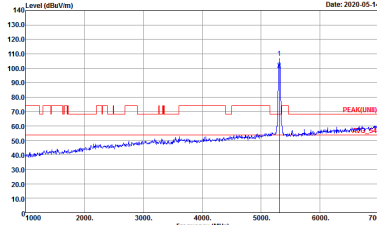
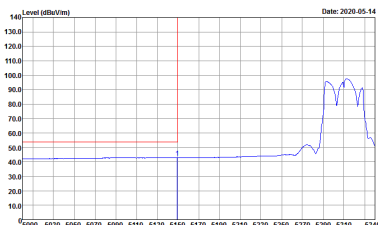

WIFI	Band 2 5250~5350MHz Band Edge @ 3m	
ANT	802.11n HT40 CH62 5310 - L	
4+3	Horizontal	Fundamental
<p>Peak</p>	 <p>Site : 03CH16-#Y Condition : PEAK_BE_74 3m 91200_1522 HORIZONTAL RBW:1000.000KHz VBW:3000.000KHz SWT:Auto Detector : Peak</p>	 <p>Site : 03CH16-#Y Condition : PEAK(UNIT) 3m 91200_1522 HORIZONTAL RBW:1000.000KHz VBW:3000.000KHz SWT:Auto Detector : Peak</p>
<p>Avg.</p>	 <p>Site : 03CH16-#Y Condition : AVG_BE_54 3m 91200_1522 HORIZONTAL RBW:1000.000KHz VBW:0.010KHz SWT:Auto Detector : Peak</p>	<p>Left blank</p>

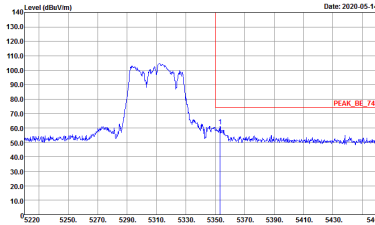
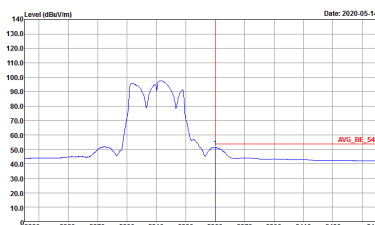

WIFI	Band 2 5250~5350MHz Band Edge @ 3m	
ANT	802.11n HT40 CH62 5310 - R	
4+3	Horizontal	Fundamental
<p>Peak</p>	 <p>Site : 03CH16-HY Condition : PEAK_BE_74 3m 91200_1522 HORIZONTAL : RBW:1000.000KHz VBW:3000.000KHz SWT:Auto Detector : Peak</p>	<p>Left blank</p>
<p>Avg.</p>	 <p>Site : 03CH16-HY Condition : AVG_BE_54 3m 91200_1522 HORIZONTAL : RBW:1000.000KHz VBW:0.010KHz SWT:Auto Detector : Peak</p>	<p>Left blank</p>

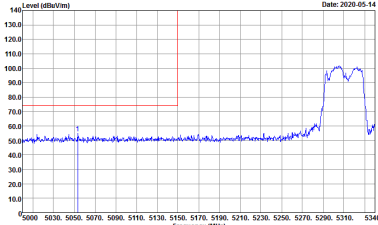
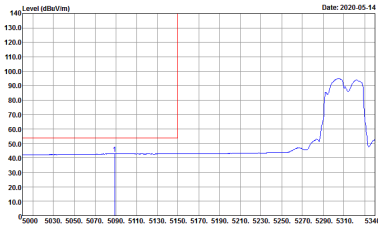

WIFI	Band 2 5250~5350MHz Band Edge @ 3m	
ANT	802.11n HT40 CH62 5310 - L	
4+3	Vertical	Fundamental
<p>Peak</p>	 <p>Site : 03CH16-FY Condition : PEAK_BE_74 3m 91200_1522 VERTICAL RBW:1000.000KHz VBW:3000.000KHz SWT:Auto Detector : Peak</p>	 <p>Site : 03CH16-FY Condition : PEAK(UNIT) 3m 91200_1522 VERTICAL RBW:1000.000KHz VBW:3000.000KHz SWT:Auto Detector : Peak</p>
<p>Avg.</p>	 <p>Site : 03CH16-FY Condition : AVG_BE_54 3m 91200_1522 VERTICAL RBW:1000.000KHz VBW:0.010KHz SWT:Auto Detector : Peak</p>	<p>Left blank</p>

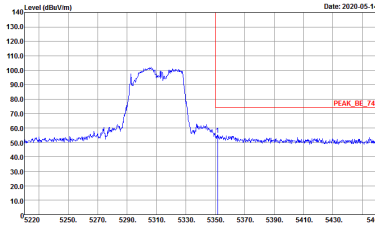
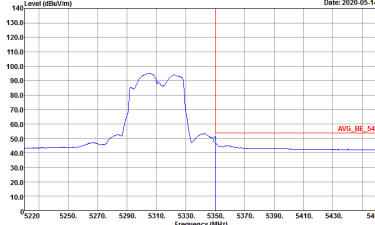

WIFI	Band 2 5250~5350MHz Band Edge @ 3m	
ANT	802.11n HT40 CH62 5310 - R	
4+3	Vertical	Fundamental
<p>Peak</p>	 <p>Site : 03CH16-HY Condition : PEAK_BE_74 3m 91200_1522 VERTICAL RBW:1000.000KHz VBW:3000.000KHz SWT:Auto Detector : Peak</p>	<p>Left blank</p>
<p>Avg.</p>	 <p>Site : 03CH16-HY Condition : AVG_BE_54 3m 91200_1522 VERTICAL RBW:1000.000KHz VBW:0.010KHz SWT:Auto Detector : Peak</p>	<p>Left blank</p>

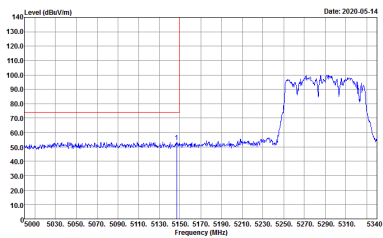
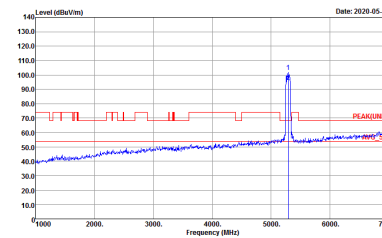
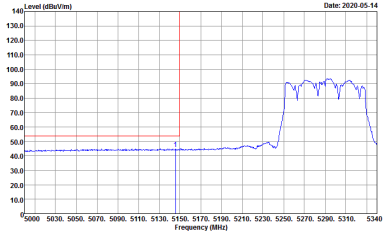

Band 2 5250~5350MHz
WIFI 802.11ac VHT80 (Band Edge @ 3m)

WIFI	Band 2 5250~5350MHz Band Edge @ 3m	
ANT	802.11ac VHT80 CH58 5290MHz - L	
4+3	Horizontal	Fundamental
Peak	 <p>Site : 03CH16-HY Condition : PEAK_BE_74 3m 91200_1522 HORIZONTAL RBW:1000.000KHz VBW:3000.000KHz SWT:Auto Detector : Peak</p>	 <p>Site : 03CH16-HY Condition : PEAK(LINII) 3m 91200_1522 HORIZONTAL RBW:1000.000KHz VBW:3000.000KHz SWT:Auto Detector : Peak</p>
Avg.	 <p>Site : 03CH16-HY Condition : AVG_BE_54 3m 91200_1522 HORIZONTAL RBW:1000.000KHz VBW:3.000KHz SWT:Auto Detector : Peak</p>	Left blank

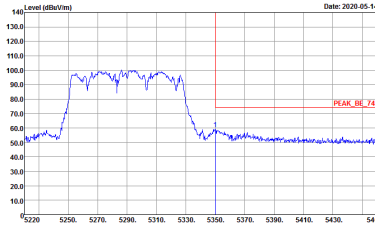
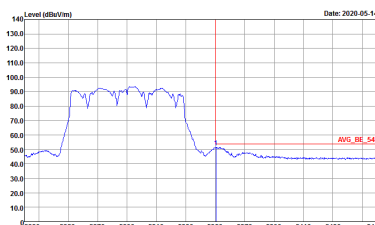

WIFI	Band 2 5250~5350MHz Band Edge @ 3m	
ANT	802.11ac VHT80 CH58 5290MHz - R	
4+3	Horizontal	Fundamental
<p>Peak</p>	 <p>Site : 03CH16-HY Condition : PEAK_BE_74 3m 91200_1522 HORIZONTAL RBW:1000.000KHz VBW:3000.000KHz SWT:Auto Detector : Peak</p>	<p>Left blank</p>
<p>Avg.</p>	 <p>Site : 03CH16-HY Condition : AVG_BE_54 3m 91200_1522 HORIZONTAL RBW:1000.000KHz VBW:3.000KHz SWT:Auto Detector : Peak</p>	<p>Left blank</p>

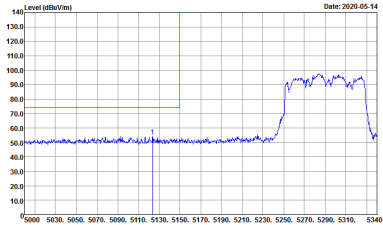
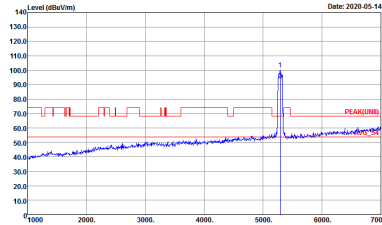
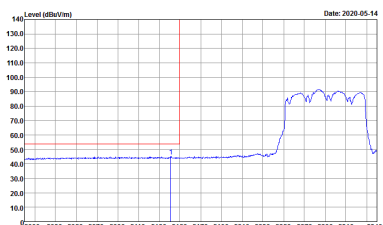

WIFI	Band 2 5250~5350MHz Band Edge @ 3m	
ANT	802.11ac VHT80 CH58 5290MHz - L	
4+3	Vertical	Fundamental
<p>Peak</p>	 <p>Site : 03CH16-HY Condition : PEAK_BE_74 3m 91200_1522 VERTICAL RBW:1000.000KHz VBW:3000.000KHz SWT:Auto Detector : Peak</p>	 <p>Site : 03CH16-HY Condition : PEAK(UNIT) 3m 91200_1522 VERTICAL RBW:1000.000KHz VBW:3000.000KHz SWT:Auto Detector : Peak</p>
<p>Avg.</p>	 <p>Site : 03CH16-HY Condition : AVG_BE_54 3m 91200_1522 VERTICAL RBW:1000.000KHz VBW:3.000KHz SWT:Auto Detector : Peak</p>	<p>Left blank</p>

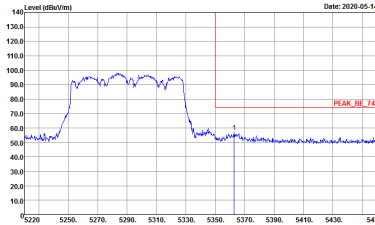
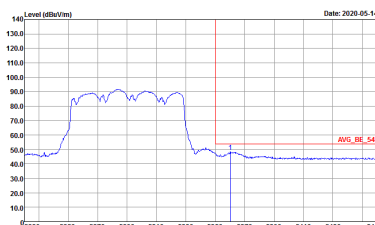

WIFI	Band 2 5250~5350MHz Band Edge @ 3m	
ANT	802.11ac VHT80 CH58 5290MHz - R	
4+3	Vertical	Fundamental
<p>Peak</p>	 <p>Site : 03CH16-HY Condition : PEAK_BE_74 3m 91200_1522 VERTICAL RBW:1000.000KHz VBW:3000.000KHz SWT:Auto Detector : Peak</p>	<p>Left blank</p>
<p>Avg.</p>	 <p>Site : 03CH16-HY Condition : AVG_BE_54 3m 91200_1522 VERTICAL RBW:1000.000KHz VBW:3.000KHz SWT:Auto Detector : Peak</p>	<p>Left blank</p>



Band 2 - 5250~5350MHz
WIFI 802.11a (Harmonic @ 3m)

WIFI	Band 2 5250~5350MHz Harmonic @ 3m	
ANT	802.11a CH52 5260MHz	
4+3	Horizontal	Vertical
Peak Avg.	<p>Site : 03CH16-HY Condition : PEAK(UNII) 3m 91200_1522 HORIZONTAL Detector : Peak</p>	<p>Site : 03CH16-HY Condition : PEAK(UNII) 3m 91200_1522 VERTICAL Detector : Peak</p>



WIFI	Band 2 5250~5350MHz Harmonic @ 3m	
ANT	802.11a CH60 5300MHz	
4+3	Horizontal	Vertical
Peak Avg.	<p>Site : 03CH16-HY Condition : PEAK(UNII) 3m 91200_1522 HORIZONTAL Detector : Peak</p>	<p>Site : 03CH16-HY Condition : PEAK(UNII) 3m 91200_1522 VERTICAL Detector : Peak</p>



WIFI	Band 2 5250~5350MHz Harmonic @ 3m	
ANT	802.11a CH64 5320MHz	
4+3	Horizontal	Vertical
Peak Avg.	<p>Site : 03CH16-HY Condition : PEAK(UNII) 3m 91200_1522 HORIZONTAL Detector : Peak</p>	<p>Site : 03CH16-HY Condition : PEAK(UNII) 3m 91200_1522 VERTICAL Detector : Peak</p>



Band 2 5250~5350MHz
WIFI 802.11n HT20 (Harmonic @ 3m)

Table with 2 columns: Horizontal and Vertical. Rows include: WIFI (Band 2 5250~5350MHz Harmonic @ 3m), ANT (802.11n HT20 CH52 5260MHz), 4+3, and Peak Avg. Each plot shows Level (dBuV/m) vs Frequency (MHz) with a red peak line and a blue average line.



WIFI	Band 2 5250~5350MHz Harmonic @ 3m	
ANT	802.11n HT20 CH60 5300MHz	
4+3	Horizontal	Vertical
Peak Avg.	<p>Site : 03CH16-HY Condition : PEAK(UNIT) 3m 91200_1522 HORIZONTAL Detector : Peak</p>	<p>Site : 03CH16-HY Condition : PEAK(UNIT) 3m 91200_1522 VERTICAL Detector : Peak</p>



WIFI	Band 2 5250~5350MHz Harmonic @ 3m	
ANT	802.11n HT20 CH64 5320MHz	
4+3	Horizontal	Vertical
Peak Avg.	<p>Site : 03CH16-HY Condition : PEAK(UNII) 3m 91200_1522 HORIZONTAL Detector : Peak</p>	<p>Site : 03CH16-HY Condition : PEAK(UNII) 3m 91200_1522 VERTICAL Detector : Peak</p>



Band 2 5250~5350MHz
WIFI 802.11n HT40 (Harmonic @ 3m)

WIFI	Band 2 5250~5350MHz Harmonic @ 3m	
ANT	802.11n HT40 CH54 5270	
4+3	Horizontal	Vertical
Peak Avg.	<p>Site : 03CH16-HY Condition : PEAK(UNII) 3m 9120D_1522 HORIZONTAL Detector : Peak</p>	<p>Site : 03CH16-HY Condition : PEAK(UNII) 3m 9120D_1522 VERTICAL Detector : Peak</p>



WIFI	Band 2 5250~5350MHz Harmonic @ 3m	
ANT	802.11n HT40 CH62 5310	
4+3	Horizontal	Vertical
Peak Avg.	<p>Site : 03CH16-HY Condition : PEAK(LINII) 3m 91200_1522 HORIZONTAL Detector : Peak</p>	<p>Site : 03CH16-HY Condition : PEAK(LINII) 3m 91200_1522 VERTICAL Detector : Peak</p>



Band 2 5250~5350MHz
WIFI 802.11ac VHT80 (Harmonic @ 3m)

WIFI	Band 2 5250~5350MHz Harmonic @ 3m	
ANT	802.11ac VHT80 CH58 5290MHz	
4+3	Horizontal	Vertical
Peak Avg.	<p>Site : 03CH16-HY Condition : PEAK(UNII) 3m 91200_1522 HORIZONTAL Detector : Peak</p>	<p>Site : 03CH16-HY Condition : PEAK(UNII) 3m 91200_1522 VERTICAL Detector : Peak</p>

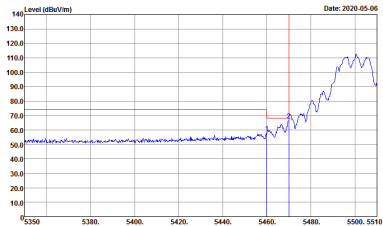
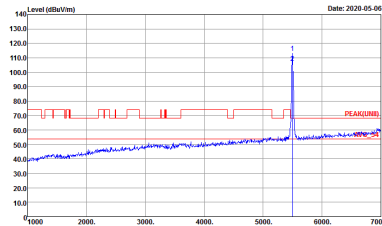
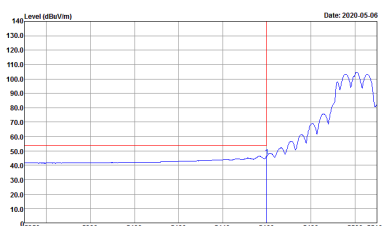

Band 3 - 5470~5725MHz
WIFI 802.11a (Band Edge @ 3m)

WIFI	Band 3 5470~5725MHz Band Edge @ 3m	
ANT	802.11a CH100 5500MHz	
4+3	Horizontal	Fundamental
Peak	 <p>Site : 03CH16-HY Condition : PEAK_BE(UNIT)_B3 3m 91200_1522 HORIZONTAL Detector : RBW:1000.000KHz VBW:3000.000KHz SWT:Auto : Peak</p>	 <p>Site : 03CH16-HY Condition : PEAK(UNIT) 3m 91200_1522 HORIZONTAL Detector : RBW:1000.000KHz VBW:3000.000KHz SWT:Auto : Peak</p>
Avg.	 <p>Site : 03CH16-HY Condition : AVG_BE(UNIT)_B3 3m 91200_1522 HORIZONTAL Detector : RBW:1000.000KHz VBW:0.010KHz SWT:Auto : Peak</p>	Left blank

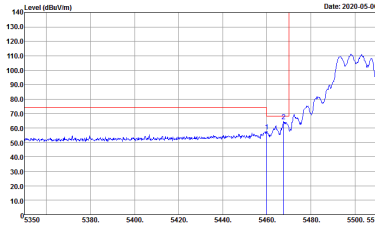
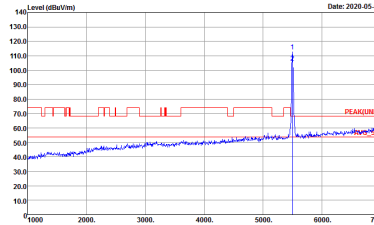
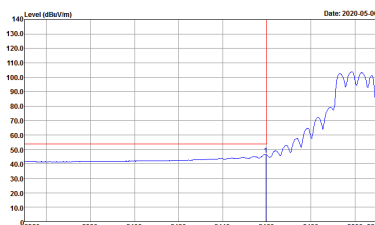

WIFI	Band 3 5470~5725MHz Band Edge @ 3m	
ANT	802.11a CH100 5500MHz	
4+3	Vertical	Fundamental
<p>Peak</p>	 <p>Site : 03CH16-HY Condition : PEAK_BE(UNIT1)_B3 3m 91200_1522 VERTICAL RBW:1000.000KHz VBW:3000.000KHz SWT:Auto Detector : Peak</p>	 <p>Site : 03CH16-HY Condition : PEAK(UNIT1) 3m 91200_1522 VERTICAL RBW:1000.000KHz VBW:3000.000KHz SWT:Auto Detector : Peak</p>
<p>Avg.</p>	 <p>Site : 03CH16-HY Condition : AVG_BE(UNIT1)_B3 3m 91200_1522 VERTICAL RBW:1000.000KHz VBW:0.010KHz SWT:Auto Detector : Peak</p>	<p>Left blank</p>

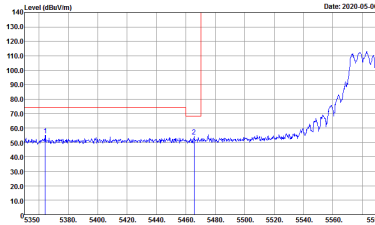
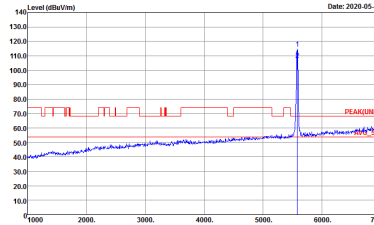
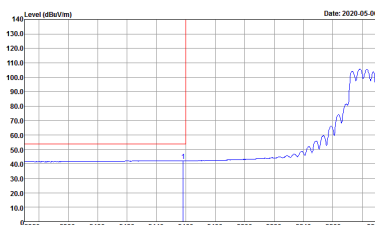

WIFI	Band 3 5470~5725MHz Band Edge @ 3m	
ANT	802.11a CH116 5580MHz - L	
4+3	Horizontal	Fundamental
<p>Peak</p>	 <p>Site : 03CH16-1FY Condition : PEAK_BE(UNIT1)_B3 3m 91200_1522 HORIZONTAL RBW:1000.000KHz VBW:3000.000KHz SWT:Auto Detector : Peak</p>	 <p>Site : 03CH16-1FY Condition : PEAK(UNIT1) 3m 91200_1522 HORIZONTAL RBW:1000.000KHz VBW:3000.000KHz SWT:Auto Detector : Peak</p>
<p>Avg.</p>	 <p>Site : 03CH16-1FY Condition : AVG_BE(UNIT1)_B3 3m 91200_1522 HORIZONTAL RBW:1000.000KHz VBW:0.010KHz SWT:Auto Detector : Peak</p>	<p>Left blank</p>



WIFI	Band 3 5470~5725MHz Band Edge @ 3m	
ANT	802.11a CH116 5580MHz - R	
4+3	Horizontal	Fundamental
Peak	<p>Site : 03CH16-HY Condition : PEAK_BE(UNIT1)_B3 3m 91200_1522 HORIZONTAL RBW:1000.000KHz VBW:3000.000KHz SWT:Auto Detector : Peak</p>	Left blank

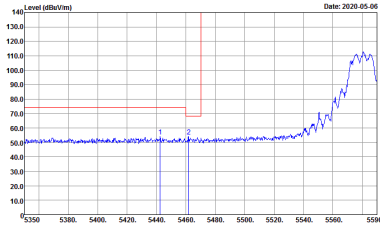
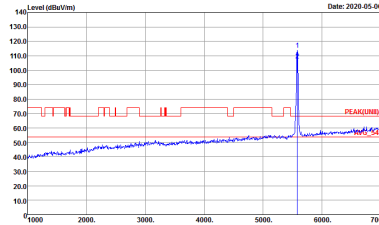
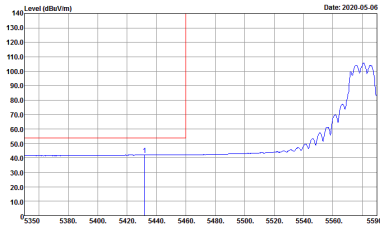

WIFI	Band 3 5470~5725MHz Band Edge @ 3m	
ANT	802.11a CH116 5580MHz - L	
4+3	Vertical	Fundamental
<p>Peak</p>	 <p>Site : 03CH16-1FY Condition : PEAK_BE(UNIT1)_B3 3m 91200_1522 VERTICAL RBW:1000.000KHz VBW:3000.000KHz SWT:Auto Detector : Peak</p>	 <p>Site : 03CH16-1FY Condition : PEAK(UNIT1) 3m 91200_1522 VERTICAL RBW:1000.000KHz VBW:3000.000KHz SWT:Auto Detector : Peak</p>
<p>Avg.</p>	 <p>Site : 03CH16-1FY Condition : AVG_BE(UNIT1)_B3 3m 91200_1522 VERTICAL RBW:1000.000KHz VBW:0.010KHz SWT:Auto Detector : Peak</p>	<p>Left blank</p>



WIFI	Band 3 5470~5725MHz Band Edge @ 3m	
ANT	802.11a CH116 5580MHz - R	
4+3	Vertical	Fundamental
Peak	<p>Site : 03CH16-HY Condition : PEAK_BE(UNIT1)_B3 3m 91200_1522 VERTICAL RBW:1000.000KHz VBW:3000.000KHz SWT:Auto Detector : Peak</p>	Left blank



WIFI	Band 3 5470~5725MHz Band Edge @ 3m	
ANT	802.11a CH140 5700MHz	
4+3	Horizontal	Fundamental
Peak	<p>Site : 03CH16-HY Condition : PEAK_BE(UNIT)_B3 3m 91200_1522 HORIZONTAL RBW:1000.000KHz VBW:3000.000KHz SWT:Auto Detector : Peak</p>	<p>Site : 03CH16-HY Condition : PEAK(UNIT) 3m 91200_1522 HORIZONTAL RBW:1000.000KHz VBW:3000.000KHz SWT:Auto Detector : Peak</p>

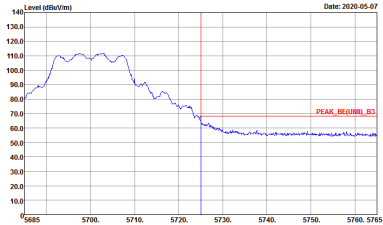
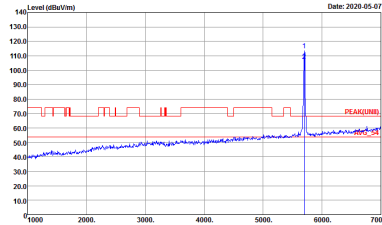

WIFI	Band 3 5470~5725MHz Band Edge @ 3m	
ANT	802.11a CH140 5700MHz	
4+3	Vertical	Fundamental
Peak	 <p>Site : 03CH16-HY Condition : PEAK_BE(UNIT1)_B3 3m 91200_1522 VERTICAL RBW:1000.000KHz VBW:3000.000KHz SWT:Auto Detector : Peak</p>	 <p>Site : 03CH16-HY Condition : PEAK(UNIT1) 3m 91200_1522 VERTICAL RBW:1000.000KHz VBW:3000.000KHz SWT:Auto Detector : Peak</p>

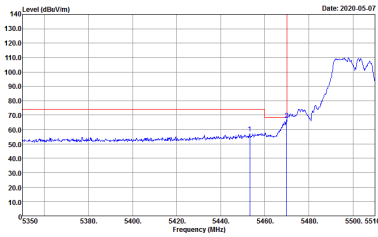
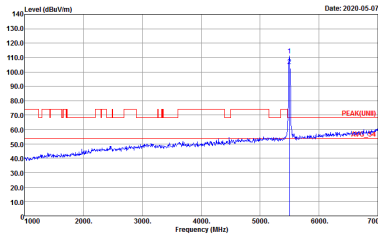
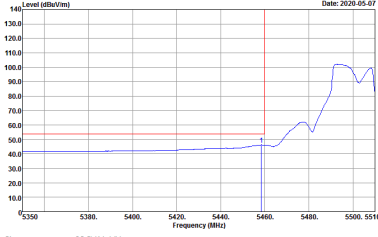

**Band 3 5470~5725MHz
WIFI 802.11n HT20 (Band Edge @ 3m)**

WIFI	Band 3 5470~5725MHz Band Edge @ 3m	
ANT	802.11n HT20 CH100 5500MHz	
4+3	Horizontal	Fundamental
Peak	 <p>Site : 03CH16-HY Condition : PEAK_BE(UNIT), B3 3m 91200_1522 HORIZONTAL RBW:1000.000KHz VBW:3000.000KHz SWT:Auto Detector : Peak</p>	 <p>Site : 03CH16-HY Condition : PEAK(UNIT) 3m 91200_1522 HORIZONTAL RBW:1000.000KHz VBW:3000.000KHz SWT:Auto Detector : Peak</p>
Avg.	 <p>Site : 03CH16-HY Condition : AVG_BE(UNIT), B3 3m 91200_1522 HORIZONTAL RBW:1000.000KHz VBW:3000.000KHz SWT:Auto Detector : Peak</p>	Left blank

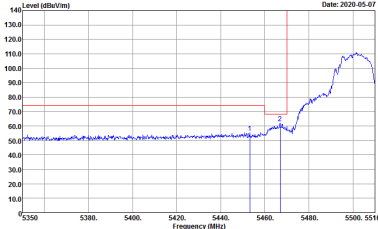
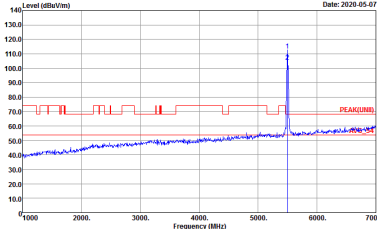
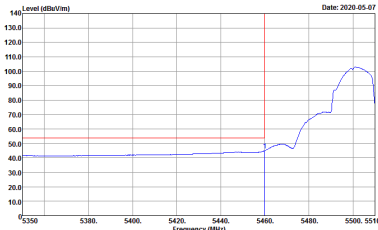

WIFI	Band 3 5470~5725MHz Band Edge @ 3m	
ANT	802.11n HT20 CH100 5500MHz	
4+3	Vertical	Fundamental
<p>Peak</p>	 <p>Site : 03CH16-HY Condition : PEAK_BE(UNIT1)_B3 3m 91200_1522 VERTICAL RBW:1000.000KHz VBW:3000.000KHz SWT:Auto Detector : Peak</p>	 <p>Site : 03CH16-HY Condition : PEAK(UNIT1) 3m 91200_1522 VERTICAL RBW:1000.000KHz VBW:3000.000KHz SWT:Auto Detector : Peak</p>
<p>Avg.</p>	 <p>Site : 03CH16-HY Condition : AVG_BE(UNIT1)_B3 3m 91200_1522 VERTICAL RBW:1000.000KHz VBW:0.010KHz SWT:Auto Detector : Peak</p>	<p>Left blank</p>

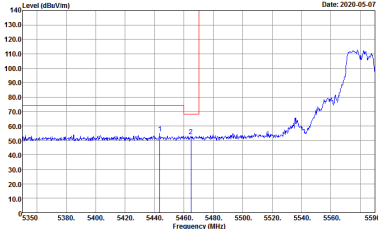
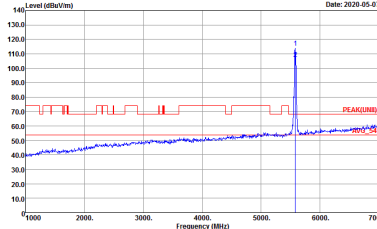
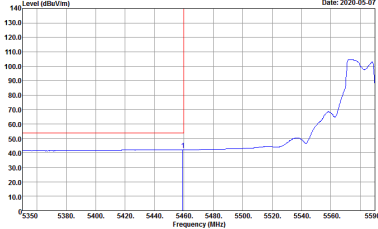

WIFI	Band 3 5470~5725MHz Band Edge @ 3m	
ANT	802.11n HT20 CH116 5580MHz - L	
4+3	Horizontal	Fundamental
<p>Peak</p>	 <p>Site : 03CH16-1FY Condition : PEAK_BE(UNIT1)_B3 3m 91200_1522 HORIZONTAL RBW:1000.000KHz VBW:3000.000KHz SWT:Auto Detector : Peak</p>	 <p>Site : 03CH16-1FY Condition : PEAK(UNIT1) 3m 91200_1522 HORIZONTAL RBW:1000.000KHz VBW:3000.000KHz SWT:Auto Detector : Peak</p>
<p>Avg.</p>	 <p>Site : 03CH16-1FY Condition : AVG_BE(UNIT1)_B3 3m 91200_1522 HORIZONTAL RBW:1000.000KHz VBW:0.010KHz SWT:Auto Detector : Peak</p>	<p>Left blank</p>

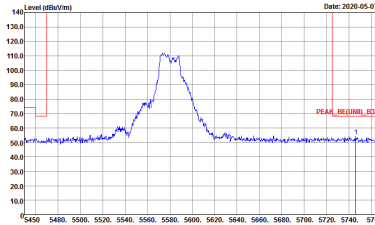

WIFI	Band 3 5470~5725MHz Band Edge @ 3m	
ANT	802.11n HT20 CH116 5580MHz - R	
4+3	Horizontal	Fundamental
Peak	 <p>Site : 03CH16-HY Condition : PEAK_BE(UNIT1)_B3 3m 91200_1522 HORIZONTAL RBW:1000.000KHz VBW:3000.000KHz SWT:Auto Detector : Peak</p>	Left blank

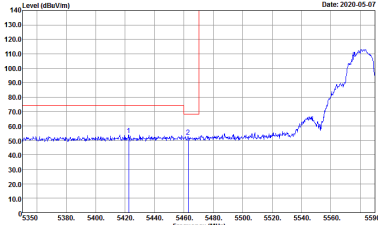
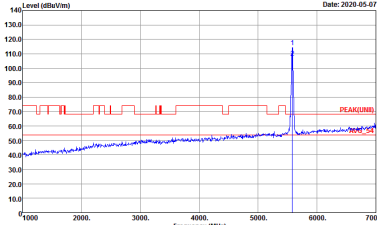
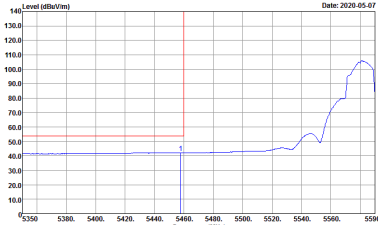

WIFI	Band 3 5470~5725MHz Band Edge @ 3m	
ANT	802.11n HT20 CH116 5580MHz - L	
4+3	Vertical	Fundamental
<p>Peak</p>	 <p>Site : 03CH16-1FY Condition : PEAK_BE(UNIT1)_B3 3m 91200_1522 VERTICAL RBW:1000.000KHz VBW:3000.000KHz SWT:Auto Detector : Peak</p>	 <p>Site : 03CH16-1FY Condition : PEAK(UNIT1) 3m 91200_1522 VERTICAL RBW:1000.000KHz VBW:3000.000KHz SWT:Auto Detector : Peak</p>
<p>Avg.</p>	 <p>Site : 03CH16-1FY Condition : AVG_BE(UNIT1)_B3 3m 91200_1522 VERTICAL RBW:1000.000KHz VBW:0.010KHz SWT:Auto Detector : Peak</p>	<p>Left blank</p>



WIFI	Band 3 5470~5725MHz Band Edge @ 3m	
ANT	802.11n HT20 CH116 5580MHz - R	
4+3	Vertical	Fundamental
Peak	<p>Site : 03CH16-HY Condition : PEAK_BE(UNIT1)_B3 3m 91200_1522 VERTICAL RBW:1000.000KHz VBW:3000.000KHz SWT:Auto Detector : Peak</p>	Left blank

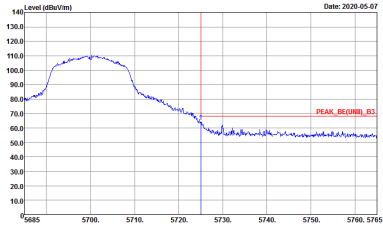
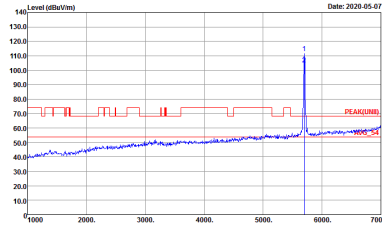

WIFI	Band 3 5470~5725MHz Band Edge @ 3m	
ANT	802.11n HT20 CH140 5700MHz	
4+3	Horizontal	Fundamental
Peak	 <p>Site : 03CH16-HY Condition : PEAK_BE(UNIT1)_B3 3m 91200_1522 HORIZONTAL RBW:1000.000KHz VBW:3000.000KHz SWT:Auto Detector : Peak</p>	 <p>Site : 03CH16-HY Condition : PEAK(UNIT1) 3m 91200_1522 HORIZONTAL RBW:1000.000KHz VBW:3000.000KHz SWT:Auto Detector : Peak</p>

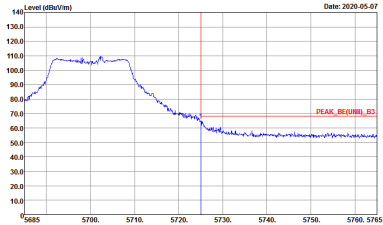
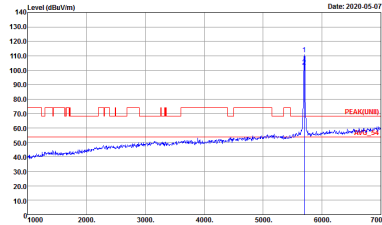

WIFI	Band 3 5470~5725MHz Band Edge @ 3m	
ANT	802.11n HT20 CH140 5700MHz	
4+3	Vertical	Fundamental
Peak.	 <p>Site : 03CH16-HY Condition : PEAK_BE(UNIT1)_B3 3m 91200_1522 VERTICAL RBW:1000.000KHz VBW:3000.000KHz SWT:Auto Detector : Peak</p>	 <p>Site : 03CH16-HY Condition : PEAK(UNIT1) 3m 91200_1522 VERTICAL RBW:1000.000KHz VBW:3000.000KHz SWT:Auto Detector : Peak</p>



Band 3 5470~5725MHz
WIFI 802.11n HT40 (Band Edge @ 3m)

Table with 2 columns (WIFI, ANT) and 2 rows (4+3, Peak, Avg.). It contains spectral analysis graphs for Horizontal and Fundamental signals, and a 'Left blank' label. Each graph shows Level (dBuV/m) vs Frequency (MHz) with specific parameters like Site, Condition, RBW, and Detector.



WIFI	Band 3 5470~5725MHz Band Edge @ 3m	
ANT	802.11n HT40 CH102 5510MHz - R	
4+3	Horizontal	Fundamental
Peak	<p>Site : 03CH16-HY Condition : PEAK_BE(UNIT1)_B3 3m 91200_1522 HORIZONTAL RBW:1000.000KHz VBW:3000.000KHz SWT:Auto Detector : Peak</p>	Left blank

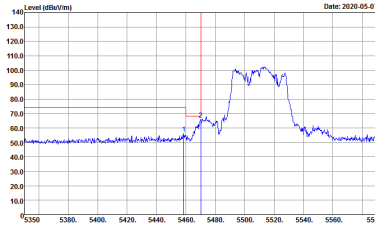
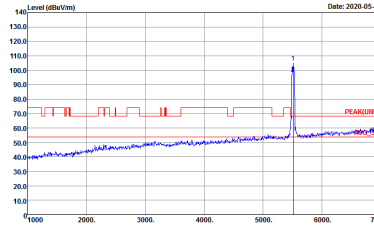
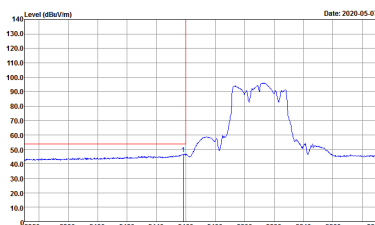

WIFI	Band 3 5470~5725MHz Band Edge @ 3m	
ANT	802.11n HT40 CH102 5510MHz - L	
4+3	Vertical	Fundamental
<p>Peak</p>	 <p>Site : 03CH16-1FY Condition : PEAK_BE(UNIT1)_B3 3m 91200_1522 VERTICAL RBW:1000.000KHz VBW:3000.000KHz SWT:Auto Detector : Peak</p>	 <p>Site : 03CH16-1FY Condition : PEAK(UNIT1) 3m 91200_1522 VERTICAL RBW:1000.000KHz VBW:3000.000KHz SWT:Auto Detector : Peak</p>
<p>Avg.</p>	 <p>Site : 03CH16-1FY Condition : AVG_BE(UNIT1)_B3 3m 91200_1522 VERTICAL RBW:1000.000KHz VBW:3.000KHz SWT:Auto Detector : Peak</p>	<p>Left blank</p>



WIFI	Band 3 5470~5725MHz Band Edge @ 3m	
ANT	802.11n HT40 CH102 5510MHz - R	
4+3	Vertical	Fundamental
Peak	<p>Site : 03CH16-HY Condition : PEAK_BE(UNIT1)_B3 3m 91200_1522 VERTICAL RBW:1000.000KHz VBW:3000.000KHz SWT:Auto Detector : Peak</p>	Left blank

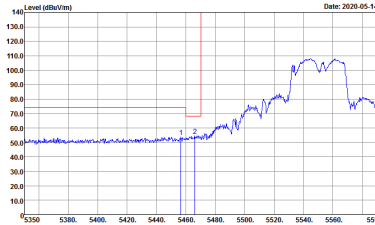
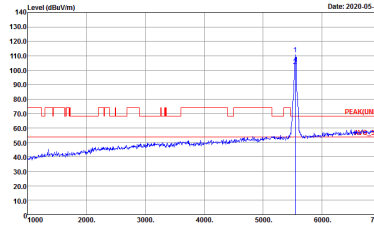
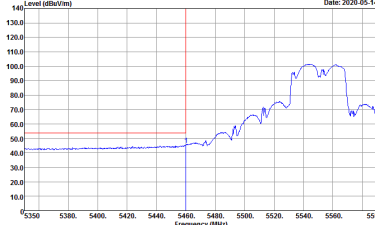

WIFI	Band 3 5470~5725MHz Band Edge @ 3m	
ANT	802.11n HT40 CH110 5550MHz - L	
4+3	Horizontal	Fundamental
<p>Peak</p>	 <p>Site : 03CH16-1FY Condition : PEAK_BE(UNIT1)_B3 3m 91200_1522 HORIZONTAL RBW:1000.000KHz VBW:3000.000KHz SWT:Auto Detector : Peak</p>	 <p>Site : 03CH16-1FY Condition : PEAK(UNIT1) 3m 91200_1522 HORIZONTAL RBW:1000.000KHz VBW:3000.000KHz SWT:Auto Detector : Peak</p>
<p>Avg.</p>	 <p>Site : 03CH16-1FY Condition : AVG_BE(UNIT1)_B3 3m 91200_1522 HORIZONTAL RBW:1000.000KHz VBW:3.000KHz SWT:Auto Detector : Peak</p>	<p>Left blank</p>



WIFI	Band 3 5470~5725MHz Band Edge @ 3m	
ANT	802.11n HT40 CH110 5550MHz - R	
4+3	Horizontal	Fundamental
Peak	<p>Site : 03CH16-HY Condition : PEAK_BE(UNIT1)_B3 3m 91200_1522 HORIZONTAL RBW:1000.000KHz VBW:3000.000KHz SWT:Auto Detector : Peak</p>	Left blank

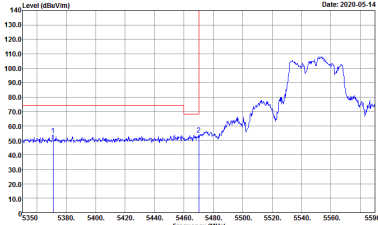
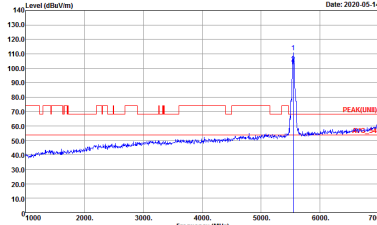
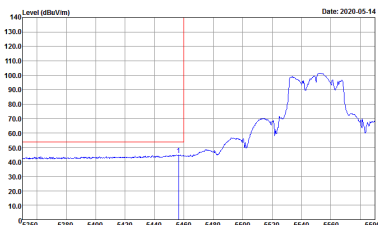

WIFI	Band 3 5470~5725MHz Band Edge @ 3m	
ANT	802.11n HT40 CH110 5550MHz - L	
4+3	Vertical	Fundamental
<p>Peak</p>	 <p>Site : 03CH16-HY Condition : PEAK_BE(UNIT1)_B3 3m 91200_1522 VERTICAL RBW:1000.000KHz VBW:3000.000KHz SWT:Auto Detector : Peak</p>	 <p>Site : 03CH16-HY Condition : PEAK(UNIT1) 3m 91200_1522 VERTICAL RBW:1000.000KHz VBW:3000.000KHz SWT:Auto Detector : Peak</p>
<p>Avg.</p>	 <p>Site : 03CH16-HY Condition : AVG_BE(UNIT1)_B3 3m 91200_1522 VERTICAL RBW:1000.000KHz VBW:3.000KHz SWT:Auto Detector : Peak</p>	<p>Left blank</p>

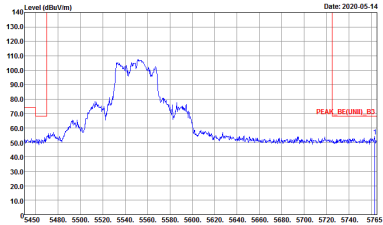

WIFI	Band 3 5470~5725MHz Band Edge @ 3m	
ANT	802.11n HT40 CH110 5550MHz - R	
4+3	Vertical	Fundamental
Peak	 <p>Site : 03CH16-HY Condition : PEAK_BE(UNIT1)_B3 3m 91200_1522 VERTICAL RBW:1000.000KHz VBW:3000.000KHz SWT:Auto Detector : Peak</p>	Left blank

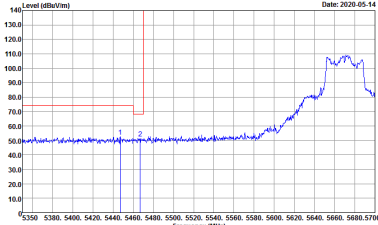
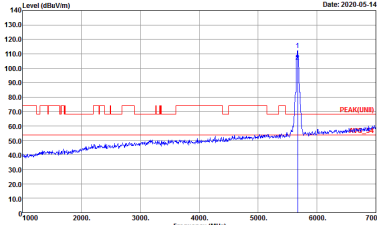
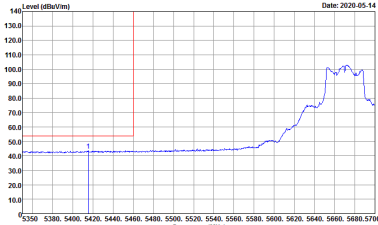

WIFI	Band 3 5470~5725MHz Band Edge @ 3m	
ANT	802.11n HT40 CH134 5670MHz - L	
4+3	Horizontal	Fundamental
<p>Peak</p>	 <p>Site : 03CH16-HY Condition : PEAK_BE(UNIT1)_B3 3m 91200_1522 HORIZONTAL RBW:1000.000KHz VBW:3000.000KHz SWT:Auto Detector : Peak</p>	 <p>Site : 03CH16-HY Condition : PEAK(UNIT1) 3m 91200_1522 HORIZONTAL RBW:1000.000KHz VBW:3000.000KHz SWT:Auto Detector : Peak</p>
<p>Avg.</p>	 <p>Site : 03CH16-HY Condition : AVG_BE(UNIT1)_B3 3m 91200_1522 HORIZONTAL RBW:1000.000KHz VBW:3.000KHz SWT:Auto Detector : Peak</p>	<p>Left blank</p>



WIFI	Band 3 5470~5725MHz Band Edge @ 3m	
ANT	802.11n HT40 CH134 5670MHz - R	
4+3	Horizontal	Fundamental
Peak	<p>Site : 03CH16-HY Condition : PEAK_BE(UNIT1)_B3 3m 91200_1522 HORIZONTAL RBW:1000.000KHz VBW:3000.000KHz SWT:Auto Detector : Peak</p>	Left blank

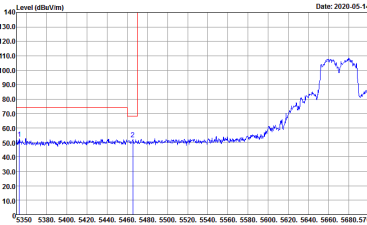
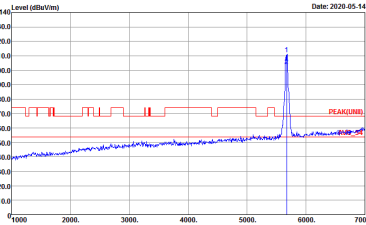
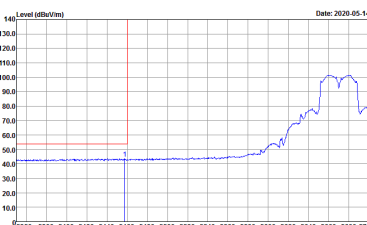

WIFI	Band 3 5470~5725MHz Band Edge @ 3m	
ANT	802.11n HT40 CH134 5670MHz - L	
4+3	Vertical	Fundamental
<p>Peak</p>	 <p>Site : 03CH16-HY Condition : PEAK_BE(UNIT1)_B3 3m 91200_1522 VERTICAL RBW:1000.000KHz VBW:3000.000KHz SWT:Auto Detector : Peak</p>	 <p>Site : 03CH16-HY Condition : PEAK(UNIT1) 3m 91200_1522 VERTICAL RBW:1000.000KHz VBW:3000.000KHz SWT:Auto Detector : Peak</p>
<p>Avg.</p>	 <p>Site : 03CH16-HY Condition : AVG_BE(UNIT1)_B3 3m 91200_1522 VERTICAL RBW:1000.000KHz VBW:3.000KHz SWT:Auto Detector : Peak</p>	<p>Left blank</p>



WIFI	Band 3 5470~5725MHz Band Edge @ 3m	
ANT	802.11n HT40 CH134 5670MHz - R	
4+3	Vertical	Fundamental
Peak	<p>Site : 03CH16-HY Condition : PEAK_BE(UNIT1)_B3 3m 91200_1522 VERTICAL RBW:1000.000KHz VBW:3000.000KHz SWT:Auto Detector : Peak</p>	Left blank

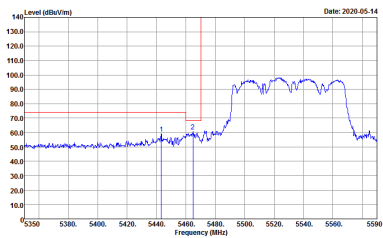
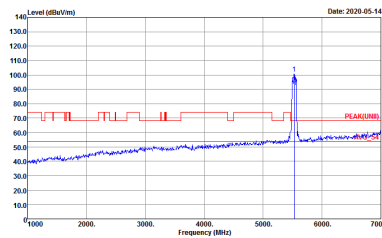
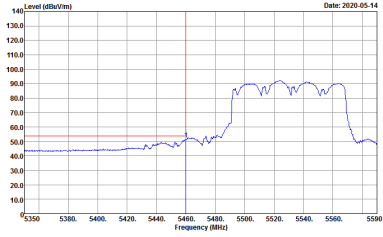

Band 3 5470~5725MHz
WIFI 802.11ac VHT80 (Band Edge @ 3m)

WIFI	Band 3 5470~5725MHz Band Edge @ 3m	
ANT	802.11ac VHT80 CH106 5530MHz - L	
4+3	Horizontal	Fundamental
<p>Peak</p>	 <p>Site : 03CH16-HY Condition : PEAK_BE(UNIT), B3 3m 91200_1522 HORIZONTAL RBW:1000.000KHz VBW:3000.000KHz SWT:Auto Detector : Peak</p>	 <p>Site : 03CH16-HY Condition : PEAK(UNIT) 3m 91200_1522 HORIZONTAL RBW:1000.000KHz VBW:3000.000KHz SWT:Auto Detector : Peak</p>
<p>Avg.</p>	 <p>Site : 03CH16-HY Condition : AVG_BE(UNIT), B3 3m 91200_1522 HORIZONTAL RBW:1000.000KHz VBW:3.000KHz SWT:Auto Detector : Peak</p>	<p>Left blank</p>



WIFI	Band 3 5470~5725MHz Band Edge @ 3m	
ANT	802.11ac VHT80 CH106 5530MHz - R	
4+3	Horizontal	Fundamental
Peak	<p>Site : 03CH16-HY Condition : PEAK_BE(UNIT1)_B3 3m 91200_1522 HORIZONTAL RBW:1000.000KHz VBW:3000.000KHz SWT:Auto Detector : Peak</p>	Left blank

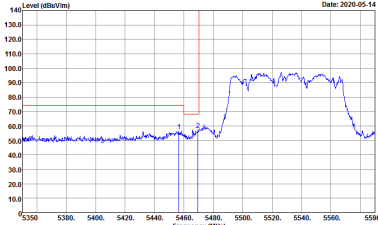
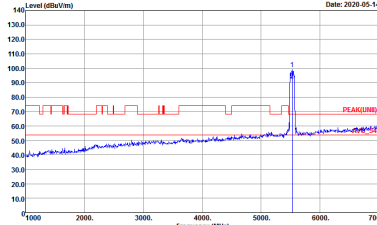
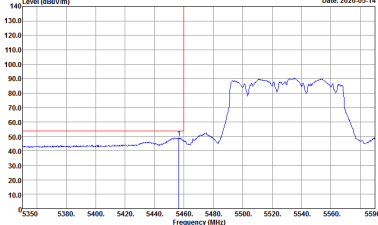

WIFI	Band 3 5470~5725MHz Band Edge @ 3m	
ANT	802.11ac VHT80 CH106 5530MHz - L	
4+3	Vertical	Fundamental
<p>Peak</p>	 <p>Site : 03CH16-HY Condition : PEAK_BE(UNIT1)_B3 3m 91200_1522 VERTICAL RBW:1000.000KHz VBW:3000.000KHz SWT:Auto Detector : Peak</p>	 <p>Site : 03CH16-HY Condition : PEAK(UNIT1) 3m 91200_1522 VERTICAL RBW:1000.000KHz VBW:3000.000KHz SWT:Auto Detector : Peak</p>
<p>Avg.</p>	 <p>Site : 03CH16-HY Condition : AVG_BE(UNIT1)_B3 3m 91200_1522 VERTICAL RBW:1000.000KHz VBW:3.000KHz SWT:Auto Detector : Peak</p>	<p>Left blank</p>



WIFI	Band 3 5470~5725MHz Band Edge @ 3m	
ANT	802.11ac VHT80 CH106 5530MHz - R	
4+3	Vertical	Fundamental
Peak	<p>Site : 03CH16-HY Condition : PEAK_BE(UNIT1)_B3 3m 91200_1522 VERTICAL RBW:1000.000KHz VBW:3000.000KHz SWT:Auto Detector : Peak</p>	Left blank

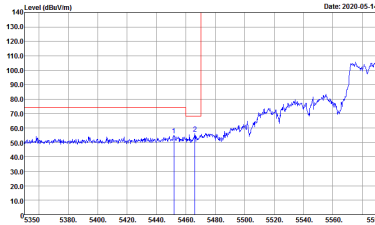
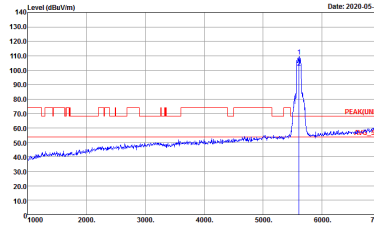
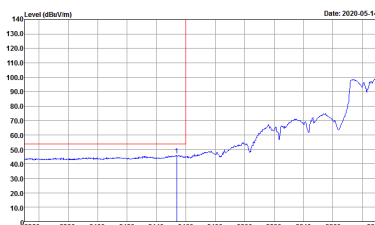

WIFI	Band 3 5470~5725MHz Band Edge @ 3m	
ANT	802.11ac VHT80 CH122 5610MHz - L	
4+3	Horizontal	Fundamental
<p>Peak</p>	 <p>Site : 03CH16-1FY Condition : PEAK_BE(UNIT1)_B3 3m 91200_1522 HORIZONTAL RBW:1000.000KHz VBW:3000.000KHz SWT:Auto Detector : Peak</p>	 <p>Site : 03CH16-1FY Condition : PEAK(UNIT1) 3m 91200_1522 HORIZONTAL RBW:1000.000KHz VBW:3000.000KHz SWT:Auto Detector : Peak</p>
<p>Avg.</p>	 <p>Site : 03CH16-1FY Condition : AVG_BE(UNIT1)_B3 3m 91200_1522 HORIZONTAL RBW:1000.000KHz VBW:3.000KHz SWT:Auto Detector : Peak</p>	<p>Left blank</p>

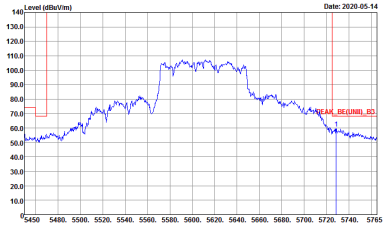

WIFI	Band 3 5470~5725MHz Band Edge @ 3m	
ANT	802.11ac VHT80 CH122 5610MHz - R	
4+3	Horizontal	Fundamental
Peak	 <p>Site : 03CH16-HY Condition : PEAK_BE(UNIT1)_B3 3m 91200_1522 HORIZONTAL RBW:1000.000KHz VBW:3000.000KHz SWT:Auto Detector : Peak</p>	Left blank

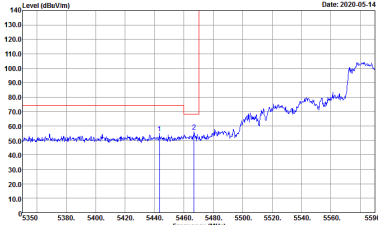
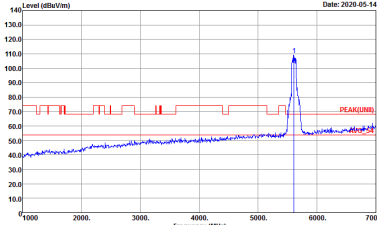
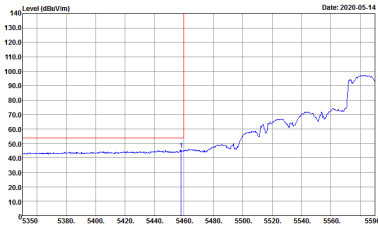

WIFI	Band 3 5470~5725MHz Band Edge @ 3m	
ANT	802.11ac VHT80 CH122 5610MHz - L	
4+3	Vertical	Fundamental
Peak	 <p>Site : 03CH16-HY Condition : PEAK_BE(UNIT1)_B3 3m 91200_1522 VERTICAL RBW:1000.000KHz VBW:3000.000KHz SWT:Auto Detector : Peak</p>	 <p>Site : 03CH16-HY Condition : PEAK(UNIT1) 3m 91200_1522 VERTICAL RBW:1000.000KHz VBW:3000.000KHz SWT:Auto Detector : Peak</p>
Avg.	 <p>Site : 03CH16-HY Condition : AVG_BE(UNIT1)_B3 3m 91200_1522 VERTICAL RBW:1000.000KHz VBW:3.000KHz SWT:Auto Detector : Peak</p>	Left blank



WIFI	Band 3 5470~5725MHz Band Edge @ 3m	
ANT	802.11ac VHT80 CH122 5610MHz - R	
4+3	Vertical	Fundamental
Peak	<p>Site : 03CH16-HY Condition : PEAK_BE(UNIT1)_B3 3m 91200_1522 VERTICAL RBW:1000.000KHz VBW:3000.000KHz SWT:Auto Detector : Peak</p>	Left blank



Band 3 - 5470~5725MHz
WIFI 802.11a (Harmonic @ 3m)

WIFI	Band 3 5470~5725MHz Harmonic @ 3m	
ANT	802.11a CH100 5500MHz	
4+3	Horizontal	Vertical
Peak Avg.	<p>Site : 03CH16-HY Condition : PEAK(UNII) 3m 91200_1522 HORIZONTAL Detector : Peak</p>	<p>Site : 03CH16-HY Condition : PEAK(UNII) 3m 91200_1522 VERTICAL Detector : Peak</p>



WIFI	Band 3 5470~5725MHz Harmonic @ 3m	
ANT	802.11a CH116 5580MHz	
4+3	Horizontal	Vertical
Peak Avg.	<p>Site : 03CH16-HY Condition : PEAK(UNII) 3m 91200_1522 HORIZONTAL Detector : Peak</p>	<p>Site : 03CH16-HY Condition : PEAK(UNII) 3m 91200_1522 VERTICAL Detector : Peak</p>



WIFI	Band 3 5470~5725MHz Harmonic @ 3m	
ANT	802.11a CH140 5700MHz	
4+3	Horizontal	Vertical
Peak Avg.	<p>Site : 03CH16-HY Condition : PEAK(LINII) 3m 91200_1522 HORIZONTAL Detector : Peak</p>	<p>Site : 03CH16-HY Condition : PEAK(LINII) 3m 91200_1522 VERTICAL Detector : Peak</p>



Band 3 5470~5725MHz
WIFI 802.11n HT20 (Harmonic @ 3m)

Table with 2 columns: Horizontal and Vertical. Each column contains a spectral plot of Level (dBuV/m) vs Frequency (MHz) with Peak and Avg. data points. Includes site and condition details for both orientations.



WIFI	Band 3 5470~5725MHz Harmonic @ 3m	
ANT	802.11n HT20 CH116 5580MHz	
4+3	Horizontal	Vertical
Peak Avg.	<p>Site : 03CH16-HY Condition : PEAK(LINII) 3m 91200_1522 HORIZONTAL Detector : Peak</p>	<p>Site : 03CH16-HY Condition : PEAK(LINII) 3m 91200_1522 VERTICAL Detector : Peak</p>