

Antenna Report

FCC ID: A4RGC3VE

6/27/2023

Google LLC

1. Test Method

The antenna gains are obtained through measurements in a fully anechoic OTA chamber with a 3D positioner.

Measurements are taken in discrete steps in theta and phi direction. Data is being recorded using a network analyzer (passive) for both theta and phi polarizations at each position resulting in a 3D gain pattern. Step size is <30deg along both axes.

Gain is derived directly through spatial averaging of VNA S21 measurements (passive measurement).

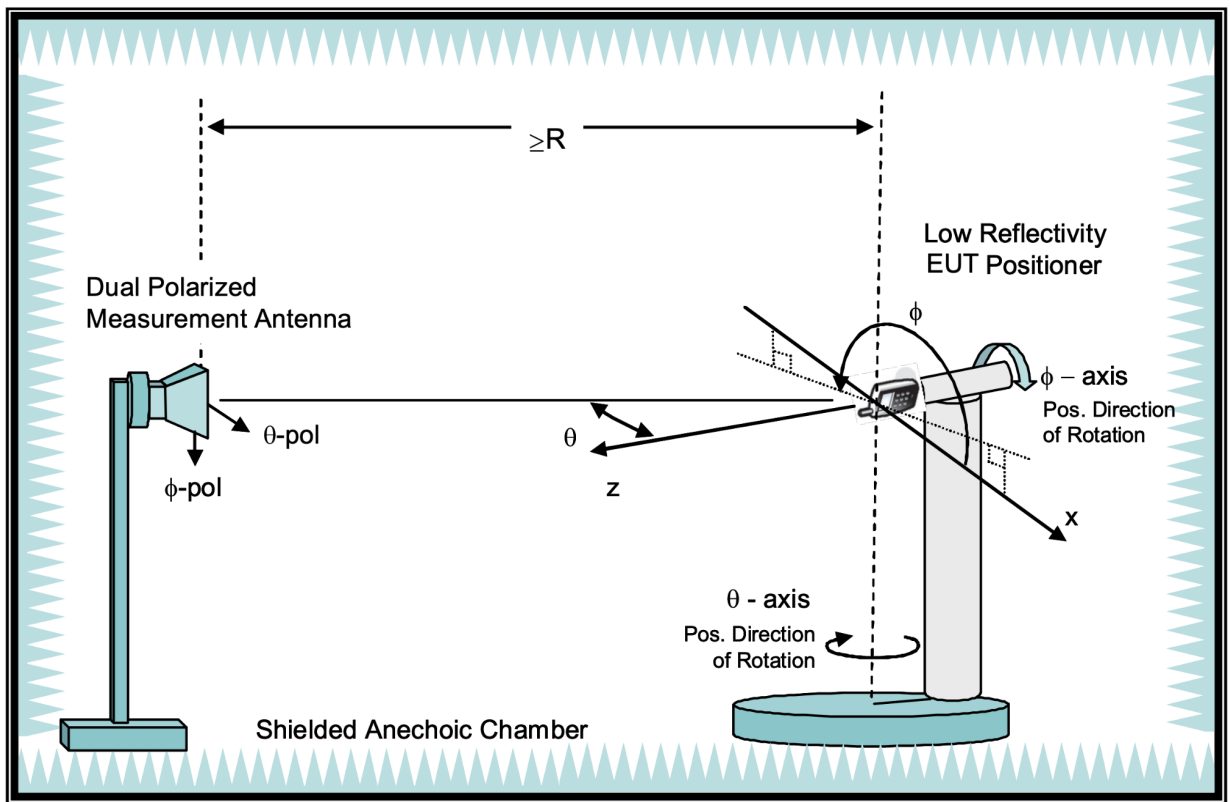

R=4.9m

2. Test Equipment and Calibration

The antenna gain measurement equipment and system are all within their calibration periods. Antenna gain measurements were divided into two chambers (2.4GHz and 5GHz (UNII-1 to UNII-4)), and 6GHz (UNII-5 to UNII-8)) due to frequency limitations.

a. Chamber 1: 2.4 GHz and 5 GHz (UNII-1 to UNII-4)

Site Description	Chamber Manufacturer	Type
AMS-8923 Multi Probe Anechoic Chamber	ETS-Lindgren	Fully Anechoic
Site location:	No. 4, Minsheng St, Tucheng District, New Taipei City, 236044, Taiwan	

Description	Manufacturer	Model
Network Analyzer	Keysight	E5071C

Equipment calibration status	- Calibration date: Jan. 11, 2023 - Due of next calibration: July, 2023
Test dates	- Feb. 6, 2023
Names of test personnel	- Siga Chen

b. Chamber 2: 6GHz (UNII-5 to UNII-8)

Site Description	Chamber Manufacturer	Type
Great-circle Anechoic Chamber	WavePro Inc.	Fully Anechoic
Site location:	10F, No. 6-3, Baoqiang Rd., Xindian Dist., New Taipei City 231609, Taiwan	

Description	Manufacturer	Model
Network Analyzer	Keysight	E5071C

Equipment calibration status	- Calibration date: Feb.17, 2022 - Due of next calibration: Feb.17, 2023
Test dates	- Feb. 3, 2023
Names of test personnel	- Yi Wu, Jason Lai

3. Site Path Loss

To provide accurate antenna gain values, the chamber is calibrated with the measured path loss. The block diagram below represents the setup of the site path loss. Path loss is provided for both polarities for all WLAN frequency ranges. Path losses were divided into two chambers (2.4GHz and 5GHz (UNII-1 to UNII-4)), and 6GHz (UNII-5 to UNII-8)) due to chamber frequency limitations.

a. Chamber 1: 2.4 GHz and 5 GHz (UNII-1 to UNII-4)

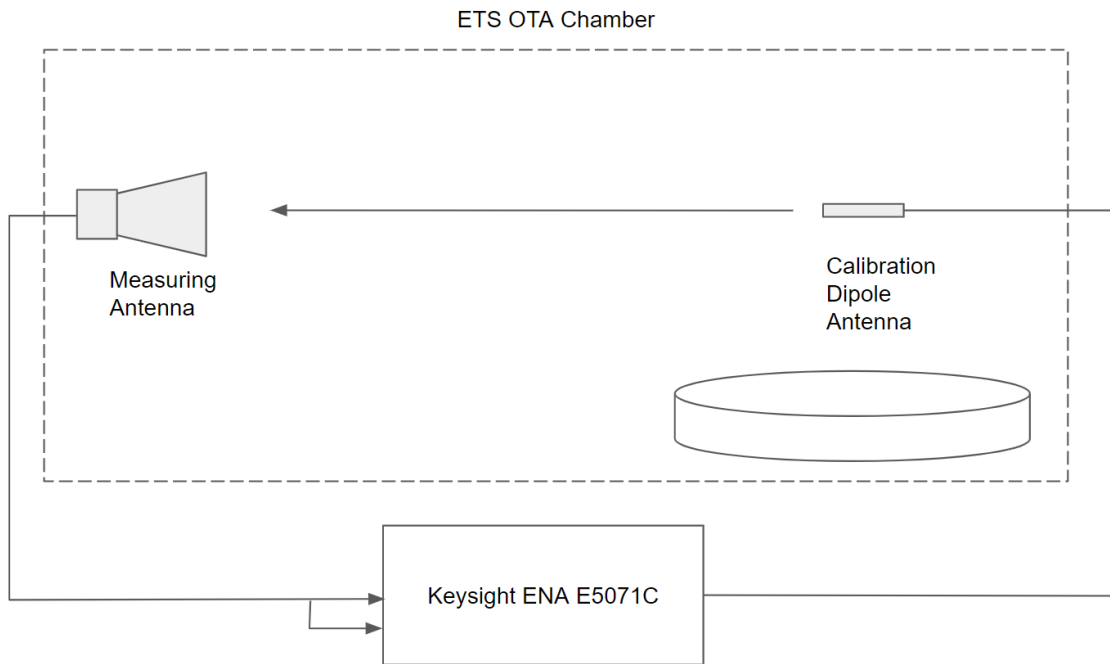

Figure: Chamber 1 Block Diagram of Path Loss

Frequency (MHz)	H-Pol Path Loss	V-Pol Path Loss
2402	-76.49	-77.29
2412	-76.98	-77.52
2437	-78.12	-77.61
2462	-78.65	-77.44
2480	-78.29	-77.26
5180	-86.04	-85.95
5280	-85.53	-84.97
5500	-85.75	-85.91
5820	-86.37	-84.98

b. Chamber 2: 6GHz (UNII-5 to UNII-8)

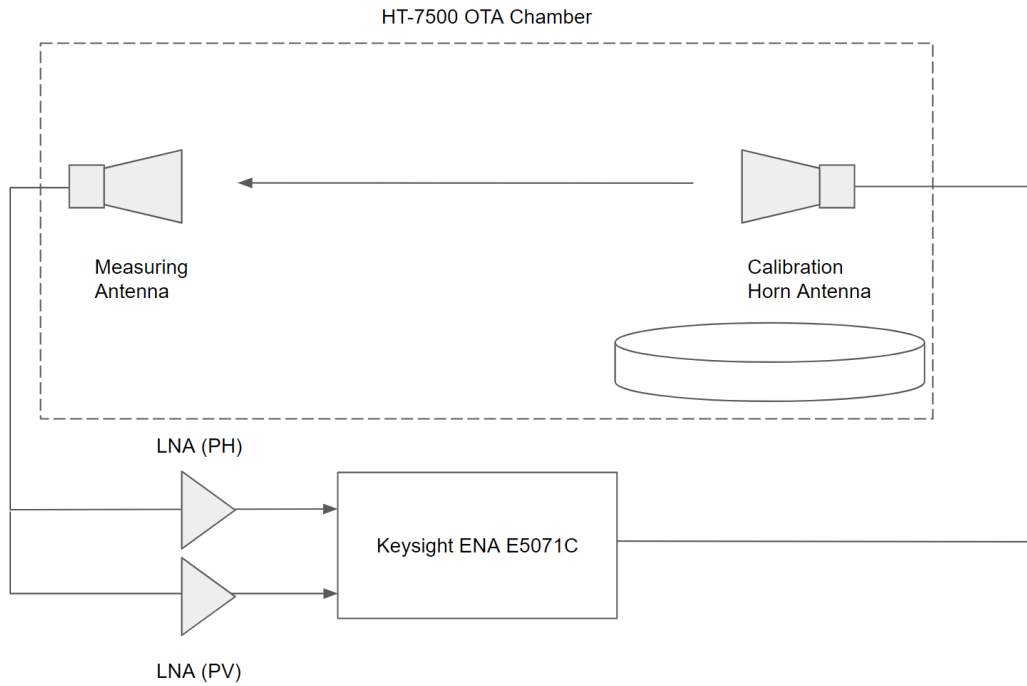

Figure: Chamber 2 Block Diagram of Path Loss

Frequency (MHz)	H-Pol Path Loss	V-Pol Path Loss
5887	-42.98	-44.31
6175	-47.48	-47.91
6475	-45.48	-45.53
6700	-47.03	-47.42
7000	-48.6	-46.18

4. Test Setup

See separate appendix document for pictures of the test setup in this filing.

5. Antenna Type

See description of antenna type below.

Antenna Name	Antenna Type
Ant3	PIFA
Ant4	IFA

6. WLAN/BT Antennas

Ant	Band	Frequency Band	Peak Gain(dBi)
Ant4	WiFi/BT 2.4 GHz	2402 MHz	-1.2
		2412 MHz	-0.5
		2437 MHz	0.9
		2462 MHz	1.0
		2480 MHz	-0.1
Ant3	WiFi/BT 2.4 GHz	2402 MHz	-3.7
		2412 MHz	-3.9
		2437 MHz	-3.3
		2462 MHz	-2.5
		2480 MHz	-1.9
Ant4	UNII-1	5180 MHz	-4.6
	UNII-2A	5280 MHz	-3.9
	UNII-2C	5500 MHz	-0.8
	UNII-3	5820 MHz	-1.4
	UNII-4	5887 MHz	-1.5
	UNII-5	6175 MHz	-2.7
	UNII-6	6475 MHz	-5.9
	UNII-7	6700 MHz	-8.0
	UNII-8	7000 MHz	-5.8
Ant3	UNII-1	5180 MHz	-2.0
	UNII-2A	5280 MHz	-2.0
	UNII-2C	5500 MHz	-0.4
	UNII-3	5820 MHz	-0.6
	UNII-4	5887 MHz	-1.2
	UNII-5	6175 MHz	-3.9
	UNII-6	6475 MHz	-3.7
	UNII-7	6700 MHz	-4.7
	UNII-8	7000 MHz	-6.7

7. Radiation Plots

Ant4:

Ant4 Freq. 2402 MHz:

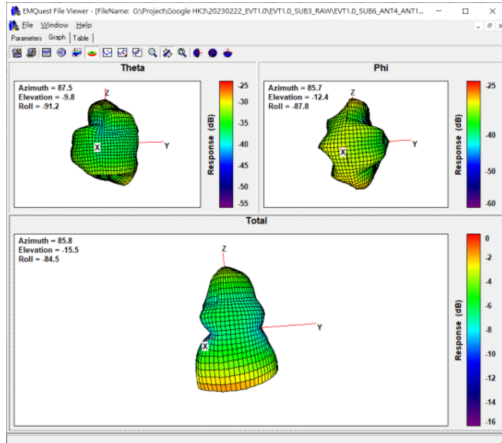

Ant4 Freq. 2437 MHz:

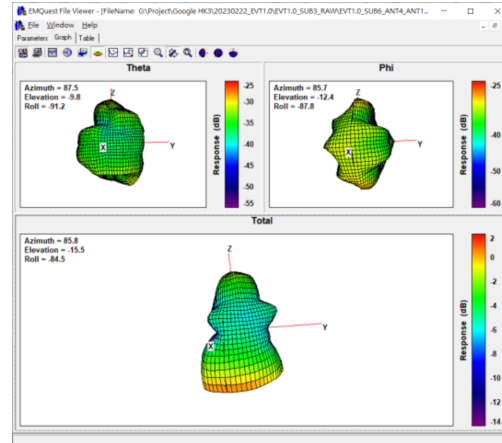

Ant4 Freq. 2412 MHz:

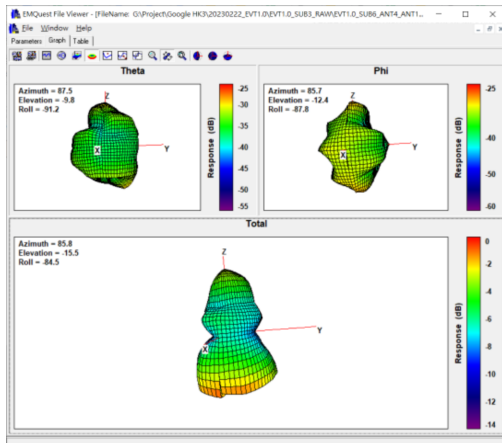

Ant4 Freq. 2462 MHz:

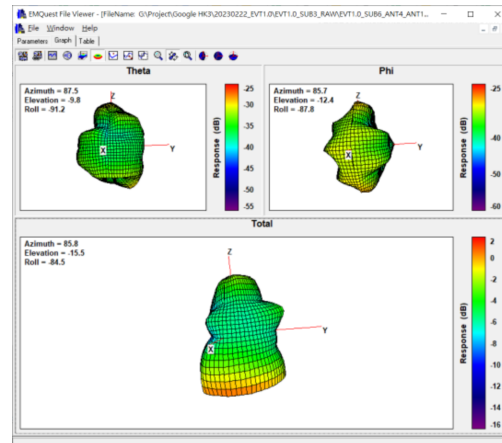

Ant4 Freq. 2480 MHz:

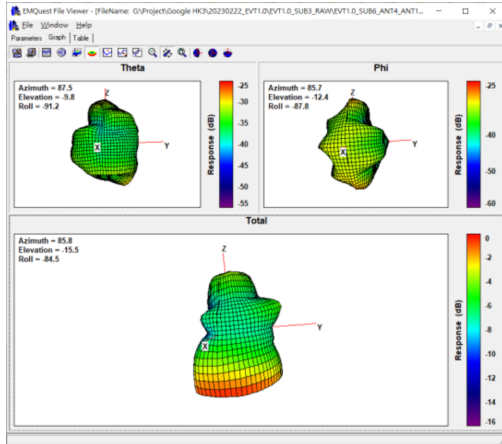

Ant4 Freq. 5500 MHz:

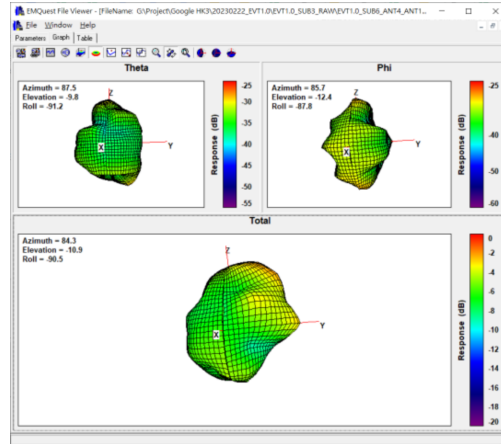

Ant4 Freq. 5180 MHz:

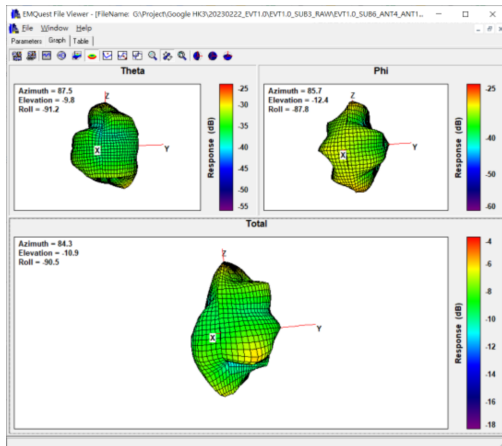

Ant4 Freq. 5820 MHz:

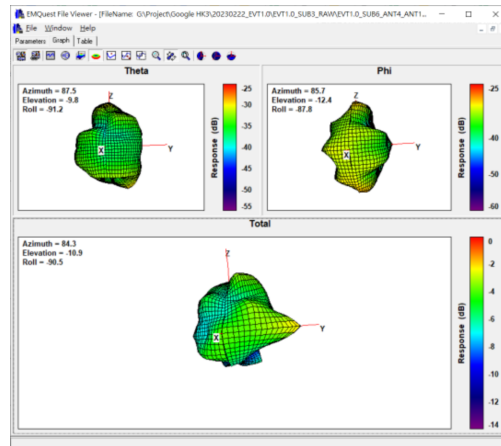

Ant4 Freq. 5280 MHz:

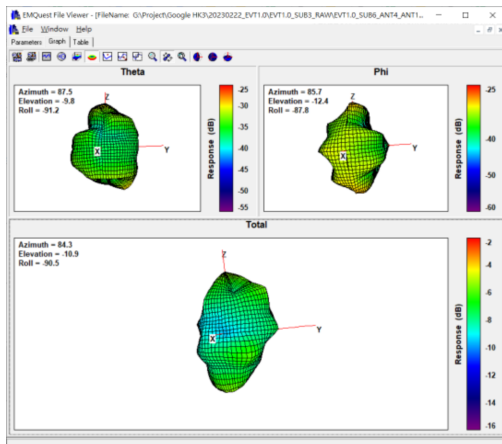

Ant4 Freq. 5887 MHz:

