

HAC_E_Dipole_835

DUT: HAC-Dipole 835 MHz

Communication System: CW; Frequency: 835 MHz; Duty Cycle: 1:1
 Medium: Air Medium parameters used: $\sigma = 0$ S/m, $\epsilon_r = 1$; $\rho = 0$ kg/m³
 Ambient Temperature : 23.5 °C

DASY5 Configuration

- Probe: EF3DV3 - SN4047; ConvF(1, 1, 1) @ 835 MHz; Calibrated: 2021/1/25
- Sensor-Surface: (Fix Surface)
- Electronics: DAE4 Sn699; Calibrated: 2021/2/16
- Phantom: HAC Test Arch with AMCC; Type: SD HAC P01 BA;
- Measurement SW: DASY52, Version 52.10 (4); SEMCAD X Version 14.6.14 (7483)

E Scan - measurement distance from the probe sensor center to CD835 = 10mm & 15mm/Hearing Aid Compatibility Test at 15mm distance (41x361x1): Interpolated grid:

$dx=0.5000$ mm, $dy=0.5000$ mm
 Device Reference Point: 0, 0, -6.3 mm
 Reference Value = 124.3 V/m; Power Drift = 0.02 dB
 PMR not calibrated. PMF = 1.000 is applied.
 E-field emissions = 115.3 V/m
 Average value of Total= $(114.4+115.3) / 2 = 114.85$ V/m

PMF scaled E-field

Grid 1 M4 113.6 V/m	Grid 2 M4 114.4 V/m	Grid 3 M4 109.2 V/m
Grid 4 M4 64.54 V/m	Grid 5 M4 64.70 V/m	Grid 6 M4 61.72 V/m
Grid 7 M4 113.4 V/m	Grid 8 M4 115.3 V/m	Grid 9 M4 111.6 V/m

Cursor:

Total = 115.3 V/m
 E Category: M4
 Location: 0.5, 74, 8.7 mm

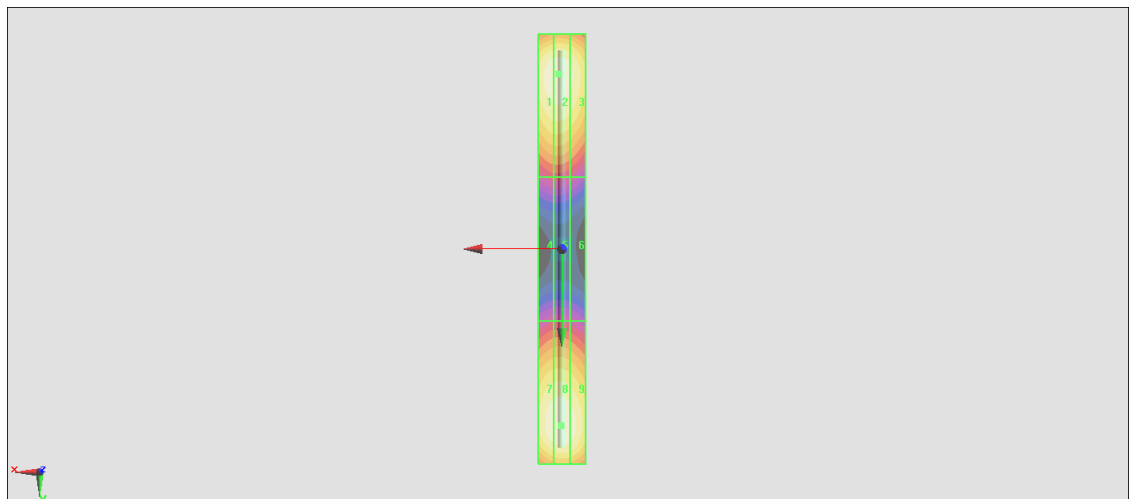
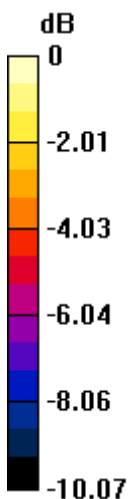

0 dB = 115.3 V/m = 41.24 dBV/m

HAC_E_Dipole_1880

DUT: HAC Dipole 1880 MHz

Communication System: CW; Frequency: 1880 MHz; Duty Cycle: 1:1

Medium: Air Medium parameters used: $\sigma = 0$ S/m, $\epsilon_r = 1$; $\rho = 0$ kg/m³

Ambient Temperature : 23.5 °C

DASY5 Configuration

- Probe: EF3DV3 - SN4047; ConvF(1, 1, 1) @ 1880 MHz; Calibrated: 2021/1/25

- Sensor-Surface: (Fix Surface)

- Electronics: DAE4 Sn699; Calibrated: 2021/2/16

- Phantom: HAC Test Arch with AMCC; Type: SD HAC P01 BA;

- Measurement SW: DASY52, Version 52.10 (4); SEMCAD X Version 14.6.14 (7483)

E Scan - measurement distance from the probe sensor center to CD1880 = 10mm & 15mm/Hearing Aid Compatibility Test at 15mm distance (41x181x1): Interpolated grid:

dx=0.5000 mm, dy=0.5000 mm

Device Reference Point: 0, 0, -6.3 mm

Reference Value = 156.9 V/m; Power Drift = 0.01 dB

PMR not calibrated. PMF = 1.000 is applied.

E-field emissions = 88.49 V/m

Average value of Total=(88.49+87.28) / 2 = 87.885 V/m

PMF scaled E-field

Grid 1 M3 88.18 V/m	Grid 2 M3 88.49 V/m	Grid 3 M3 85.07 V/m
Grid 4 M3 65.63 V/m	Grid 5 M3 65.74 V/m	Grid 6 M3 64.28 V/m
Grid 7 M3 86.57 V/m	Grid 8 M3 87.28 V/m	Grid 9 M3 84.39 V/m

Cursor:

Total = 88.49 V/m

E Category: M3

Location: 1.5, -33, 9.7 mm

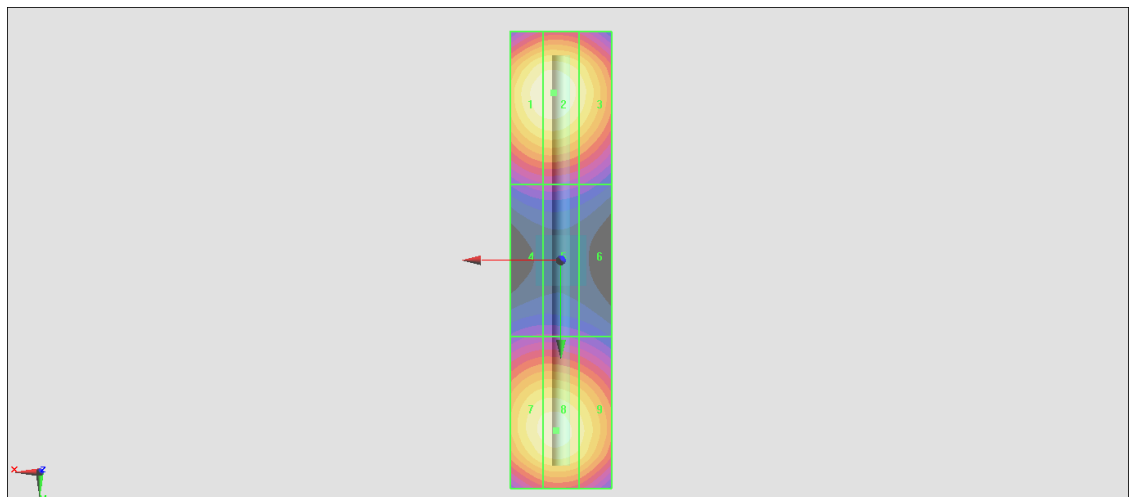
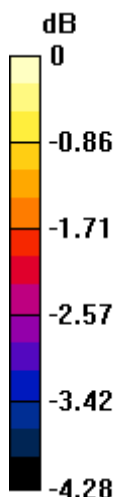

0 dB = 88.49 V/m = 38.94 dBV/m

HAC_E_Dipole_2450

DUT: HAC Dipole 2450 MHz

Communication System: CW; Frequency: 2450 MHz; Duty Cycle: 1:1

Medium: Air Medium parameters used: $\sigma = 0$ S/m, $\epsilon_r = 1$; $\rho = 0$ kg/m³

Ambient Temperature : 23.5 °C

DASY5 Configuration

- Probe: EF3DV3 - SN4047; ConvF(1, 1, 1) @ 2450 MHz; Calibrated: 2021/1/25

- Sensor-Surface: (Fix Surface)

- Electronics: DAE4 Sn699; Calibrated: 2021/2/16

- Phantom: HAC Test Arch with AMCC; Type: SD HAC P01 BA;

- Measurement SW: DASY52, Version 52.10 (4); SEMCAD X Version 14.6.14 (7483)

E Scan - measurement distance from the probe sensor center to CD2450 = 10mm & 15mm

2/Hearing Aid Compatibility Test at 15mm distance (41x181x1): Interpolated grid: dx=0.5000

mm, dy=0.5000 mm

Device Reference Point: 0, 0, -6.3 mm

Reference Value = 83.28 V/m; Power Drift = 0.01 dB

PMR not calibrated. PMF = 1.000 is applied.

E-field emissions = 88.10 V/m

Average value of Total=(86.38+88.1) / 2 = 87.24 V/m

PMF scaled E-field

Grid 1 M3 85.68 V/m	Grid 2 M3 86.38 V/m	Grid 3 M3 83.16 V/m
Grid 4 M3 77.04 V/m	Grid 5 M3 77.50 V/m	Grid 6 M3 75.57 V/m
Grid 7 M3 86.39 V/m	Grid 8 M3 88.10 V/m	Grid 9 M3 86.12 V/m

Cursor:

Total = 88.10 V/m

E Category: M3

Location: 0, 24.5, 9.7 mm

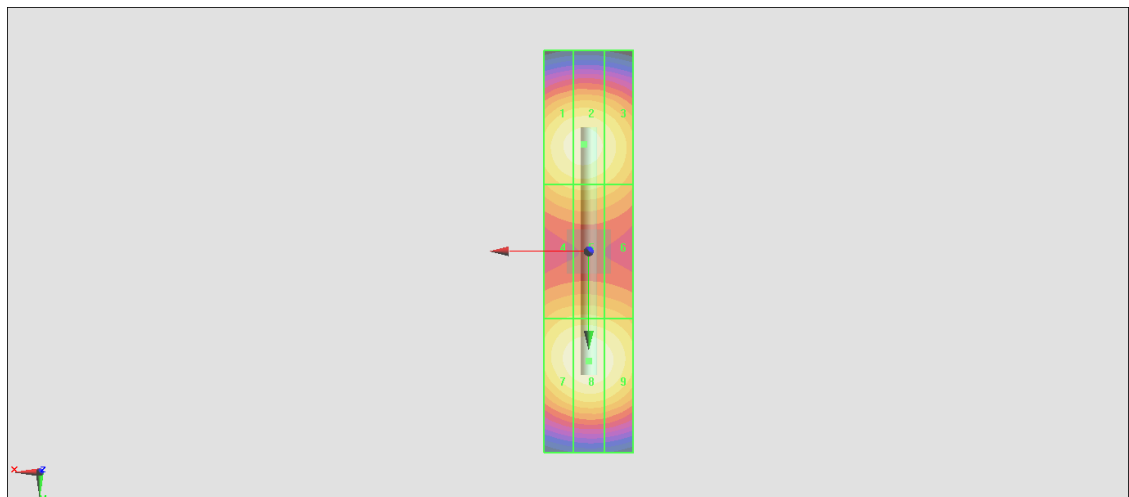
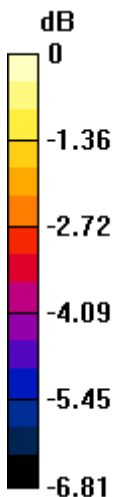

0 dB = 88.10 V/m = 38.90 dBV/m

HAC_E_Dipole_2600

DUT: HAC Dipole 2600 MHz

Communication System: CW; Frequency: 2600 MHz; Duty Cycle: 1:1
 Medium: Air Medium parameters used: $\sigma = 0 \text{ S/m}$, $\epsilon_r = 1$; $\rho = 0 \text{ kg/m}^3$
 Ambient Temperature : 23.5 °C

DASY5 Configuration

- Probe: EF3DV3 - SN4047; ConvF(1, 1, 1) @ 2600 MHz; Calibrated: 2021/1/25
- Sensor-Surface: (Fix Surface)
- Electronics: DAE4 Sn699; Calibrated: 2021/2/16
- Phantom: HAC Test Arch with AMCC; Type: SD HAC P01 BA;
- Measurement SW: DASY52, Version 52.10 (4); SEMCAD X Version 14.6.14 (7483)

E Scan - measurement distance from the probe sensor center to CD2600 = 10mm & 15mm/Hearing Aid Compatibility Test at 15mm distance (41x181x1): Interpolated grid:

$dx=0.5000 \text{ mm}$, $dy=0.5000 \text{ mm}$

Device Reference Point: 0, 0, -6.3 mm

Reference Value = 72.52 V/m; Power Drift = -0.01 dB

PMR not calibrated. PMF = 1.000 is applied.

E-field emissions = 87.46 V/m

Average value of Total= $(87.46+87.42) / 2 = 87.44 \text{ V/m}$

PMF scaled E-field

Grid 1 M3 86.71 V/m	Grid 2 M3 87.46 V/m	Grid 3 M3 84.19 V/m
Grid 4 M3 80.89 V/m	Grid 5 M3 81.30 V/m	Grid 6 M3 79.01 V/m
Grid 7 M3 86.79 V/m	Grid 8 M3 87.42 V/m	Grid 9 M3 84.66 V/m

Cursor:

Total = 87.46 V/m

E Category: M3

Location: 1, -22.5, 9.7 mm

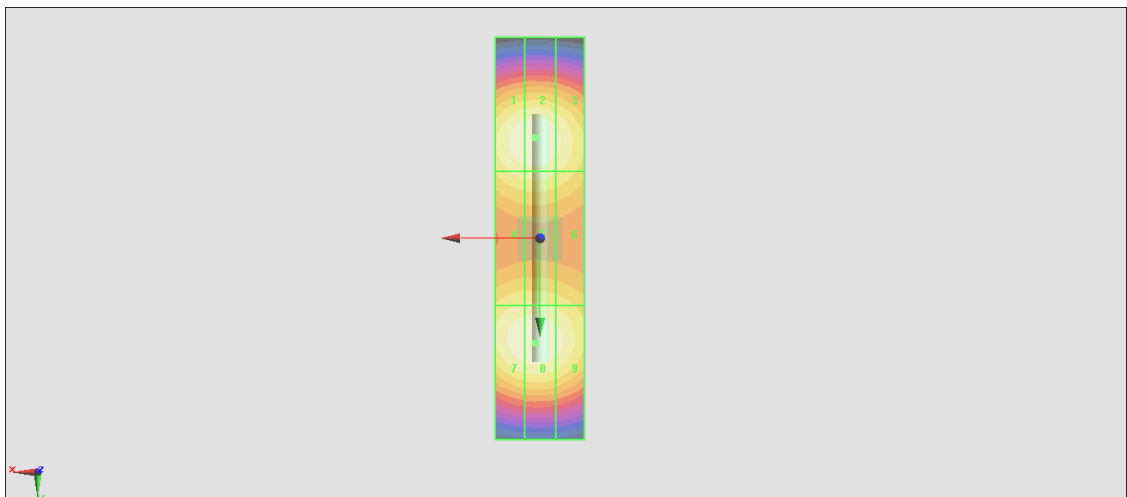
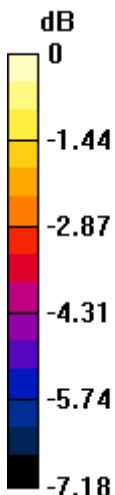

0 dB = 87.46 V/m = 38.84 dBV/m

HAC_E_Dipole_3500

DUT: HAC Dipole 3500 MHz

Communication System: CW; Frequency: 3500 MHz; Duty Cycle: 1:1
 Medium: Air Medium parameters used: $\sigma = 0$ S/m, $\epsilon_r = 1$; $\rho = 0$ kg/m³
 Ambient Temperature : 23.5 °C

DASY5 Configuration

- Probe: EF3DV3 - SN4047; ConvF(1, 1, 1) @ 3500 MHz; Calibrated: 2021/1/25
- Sensor-Surface: (Fix Surface)
- Electronics: DAE4 Sn699; Calibrated: 2021/2/16
- Phantom: HAC Test Arch with AMCC; Type: SD HAC P01 BA;
- Measurement SW: DASY52, Version 52.10 (4); SEMCAD X Version 14.6.14 (7483)

E Scan - measurement distance from the probe sensor center to CD3500 = 10mm & 15mm/Hearing Aid Compatibility Test at 15mm distance (41x121x1): Interpolated grid:

dx=0.5000 mm, dy=0.5000 mm

Device Reference Point: 0, 0, -6.3 mm

Reference Value = 38.06 V/m; Power Drift = -0.03 dB

PMR not calibrated. PMF = 1.000 is applied.

E-field emissions = 88.48 V/m

Average value of Total=(88.48+87.36) / 2 = 87.92 V/m

PMF scaled E-field

Grid 1 M3 87.79 V/m	Grid 2 M3 88.48 V/m	Grid 3 M3 85.58 V/m
Grid 4 M3 85.25 V/m	Grid 5 M3 85.73 V/m	Grid 6 M3 83.62 V/m
Grid 7 M3 87.36 V/m	Grid 8 M3 87.36 V/m	Grid 9 M3 84.30 V/m

Cursor:

Total = 88.48 V/m

E Category: M3

Location: 0.5, -14.5, 9.7 mm

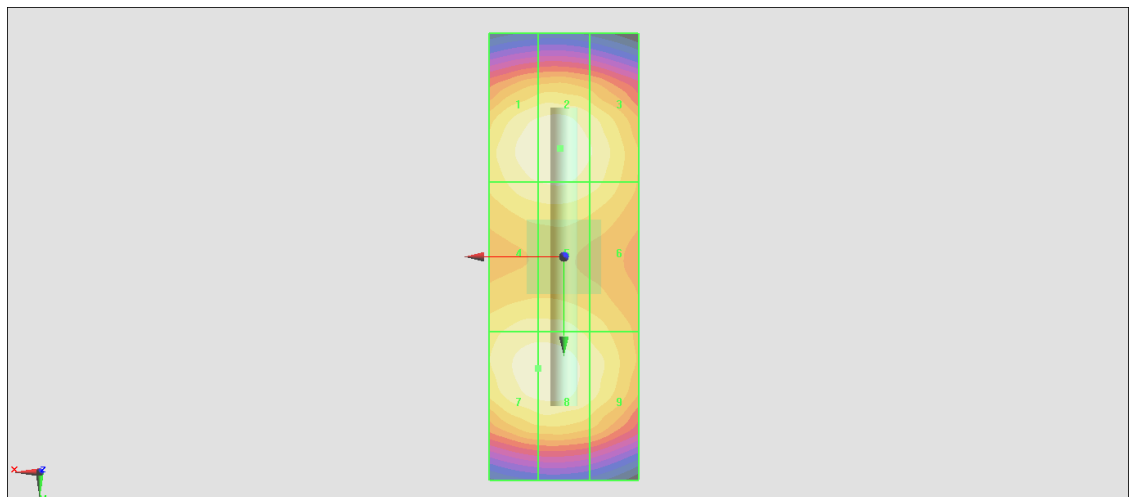
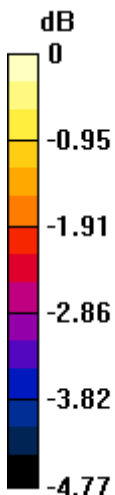

0 dB = 88.48 V/m = 38.94 dBV/m