



FCC RADIO TEST REPORT

FCC ID : A4RG9S9B
Equipment : Phone
Model Name : G9S9B
Applicant : Google LLC
1600 Amphitheatre Parkway,
Mountain View, California, 94043 USA
Standard : FCC 47 CFR Part 2, Part 27(D)

The product was received on Jun. 08, 2021 and testing was started from Jun. 08, 2021 and completed on Jul. 15, 2021. We, Sporton International Inc. EMC & Wireless Communications Laboratory, would like to declare that the tested sample has been evaluated in accordance with the test procedures given in ANSI / TIA-603-E and has been in compliance with the applicable technical standards.

The test results in this report apply exclusively to the tested model / sample. Without written approval of Sporton International Inc. EMC & Wireless Communications Laboratory, the test report shall not be reproduced except in full.

Louis Wu

Approved by: Louis Wu

Sporton International Inc. EMC & Wireless Communications Laboratory

No. 52, Huaya 1st Rd., Guishan Dist., Taoyuan City 333, Taiwan (R.O.C.)



Table of Contents

| | |
|---|-----------|
| History of this test report | 3 |
| Summary of Test Result | 4 |
| 1 General Description | 5 |
| 1.1 Product Feature of Equipment Under Test..... | 5 |
| 1.2 Product Specification of Equipment Under Test..... | 5 |
| 1.3 Modification of EUT | 6 |
| 1.4 Testing Site..... | 6 |
| 1.5 Applied Standards | 7 |
| 2 Test Configuration of Equipment Under Test | 8 |
| 2.1 Test Mode | 8 |
| 2.2 Connection Diagram of Test System..... | 9 |
| 2.3 Support Unit used in test configuration and system | 9 |
| 2.4 Measurement Results Explanation Example..... | 9 |
| 2.5 Frequency List of Low/Middle/High Channels | 10 |
| 3 Conducted Test Items | 11 |
| 3.1 Measuring Instruments | 11 |
| 3.2 Conducted Output Power Measurement and EIRP Measurement | 12 |
| 3.3 Peak-to-Average Ratio | 13 |
| 3.4 EIRP Power Density | 14 |
| 3.5 Occupied Bandwidth..... | 15 |
| 3.6 Conducted Band Edge | 16 |
| 3.7 Conducted Spurious Emission | 17 |
| 3.8 Frequency Stability | 18 |
| 4 Radiated Test Items | 19 |
| 4.1 Measuring Instruments | 19 |
| 4.2 Radiated Spurious Emission Measurement | 21 |
| 5 List of Measuring Equipment | 22 |
| 6 Uncertainty of Evaluation | 24 |
| Appendix A. Test Results of Conducted Test | |
| Appendix B. Test Results of Radiated Test | |



History of this test report

| Report No. | Version | Description | Issued Date |
|--------------|---------|-------------------------|---------------|
| FG0D2942-04I | 01 | Initial issue of report | Jul. 29, 2021 |
| | | | |
| | | | |
| | | | |
| | | | |
| | | | |
| | | | |
| | | | |
| | | | |
| | | | |
| | | | |
| | | | |
| | | | |
| | | | |
| | | | |
| | | | |
| | | | |
| | | | |
| | | | |

**Summary of Test Result**

| Report Clause | Ref Std. Clause | Test Items | Result (PASS/FAIL) | Remark |
|---------------|--------------------------|--|--------------------|---|
| 3.2 | §2.1046 | Conducted Output Power | Reporting only | - |
| 3.3 | - | Peak-to-Average Ratio | Reporting only | - |
| 3.4 | §27.50 (a)(3) | Effective Isotropic Radiated Power | Pass | - |
| 3.5 | §2.1049 | Occupied Bandwidth | Reporting only | - |
| 3.6 | §2.1051 §27.53 (a)(4) | Conducted Band Edge Measurement | Pass | - |
| 3.7 | §2.1051 §27.53 (a)(4) | Conducted Spurious Emission | Pass | - |
| 3.8 | §2.1055 §27.54 | Frequency Stability Temperature & Voltage | Pass | - |
| 4.2 | §2.1053 §27.53 (a)(4) | Radiated Spurious Emission | Pass | Under limit 18.27 dB at 9225.000 MHz for Primary Antenna Under limit 8.39 dB at 6918.000 MHz for ASDIV Antenna |

Declaration of Conformity:

The test results with all measurement uncertainty excluded are presented in accordance with the regulation limits or requirements declared by manufacturers.

Comments and Explanations:

The declared of product specification for EUT presented in the report are provided by the manufacturer, and the manufacturer takes all the responsibilities for the accuracy of product specification.

Reviewed by: William Chen**Report Producer: Lucy Wu**



1 General Description

1.1 Product Feature of Equipment Under Test

| Product Feature | |
|---------------------------------|---|
| Equipment | Phone |
| Model Name | G9S9B |
| FCC ID | A4RG9S9B |
| EUT supports Radios application | GSM/EGPRS/WCDMA/HSPA/LTE/5G NR /NFC/GNSS/WPC/WPT WLAN 11b/g/n HT20 WLAN 11a/n HT20/HT40 WLAN 11ac VHT20/VHT40/VHT80/VHT160 WLAN 11ax HE20/HE40/HE80/HE160 Bluetooth BR/EDR/LE |

Remark: The above EUT's information was declared by manufacturer.

| EUT Information List | |
|----------------------|-------------------------------|
| S/N | Performed Test Item |
| 15211FDF60006R | Conducted Measurement EIRP |
| 15211FDF600057 | Radiated Spurious Emission |

1.2 Product Specification of Equipment Under Test

| Product Specification subjective to this standard | |
|---|--|
| Tx Frequency | 2307.5 MHz ~ 2312.5 MHz |
| Rx Frequency | 2352.5 MHz ~ 2357.5 MHz |
| Bandwidth | 5MHz / 10MHz |
| Maximum Output Power to Antenna | <Primary Antenna>: 24.55 dBm <ASDIV Antenna>: 24.36 dBm |
| Antenna Type | <Primary Antenna>: ILA Antenna type <ASDIV Antenna>: ILA Antenna type |
| Type of Modulation | PI/2 BPSK / QPSK / 16QAM / 64QAM / 256QAM |

<Primary Antenna>

| Radio Tech | Band Number | Antenna name | Gain |
|------------|-------------|--------------|------|
| 5G NR | n30 | Ant 2 | -1.7 |

<ASDIV Antenna>

| Radio Tech | Band Number | Antenna name | Gain |
|------------|-------------|--------------|------|
| 5G NR | n30 | Ant 0 | -1.4 |

Remark: The above EUT's information was declared by manufacturer. Please refer to Comments and Explanations in report summary.



1.3 Modification of EUT

No modifications are made to the EUT during all test items.

1.4 Testing Site

| | |
|---------------------------|---|
| Test Site | Sporton International Inc. EMC & Wireless Communications Laboratory |
| Test Site Location | No.52, Huaya 1st Rd., Guishan Dist., Taoyuan City 333, Taiwan (R.O.C.) TEL: +886-3-327-3456 FAX: +886-3-328-4978 |
| Test Site No. | Sporton Site No. |
| | TH03-HY |
| Test Engineer | Sherry Wu |
| Temperature | 23.5~26.4°C |
| Relative Humidity | 49.8~55.5% |

| | |
|---------------------------|--|
| Test Site | Sporton International Inc. Wensan Laboratory |
| Test Site Location | No.58, Aly. 75, Ln. 564, Wenhua 3rd, Rd., Guishan Dist., Taoyuan City 333010, Taiwan (R.O.C.) TEL: +886-3-327-0868 FAX: +886-3-327-0855 |
| Test Site No. | Sporton Site No. |
| | 03CH12-HY (TAF Code: 3786) |
| Test Engineer | Jack Cheng, Lance Chiang and Chuan Chu |
| Temperature | 22.6~26.2°C |
| Relative Humidity | 56.6~68.2% |
| Remark | The Radiated Spurious Emission test item subcontracted to Sporton International Inc. Wensan Laboratory. |

Note: The test site complies with ANSI C63.4 2014 requirement.

FCC Designation No.: TW1190 and TW3786



1.5 Applied Standards

According to the specifications of the manufacturer, the EUT must comply with the requirements of the following standards:

- ♦ ANSI C63.26-2015
- ♦ FCC 47 CFR Part 2, Part 27(D)
- ♦ ANSI / TIA-603-E
- ♦ FCC KDB 971168 Power Meas License Digital Systems D01 v03r01
- ♦ FCC KDB 412172 D01 Determining ERP and EIRP v01r01
- ♦ FCC KDB 414788 D01 Radiated Test Site v01r01

Remark:

1. All test items were verified and recorded according to the standards and without any deviation during the test.
2. The TAF code is not including all the FCC KDB listed without accreditation.



2 Test Configuration of Equipment Under Test

2.1 Test Mode

Antenna port conducted and radiated test items listed below are performed according to KDB 971168 D01 Power Meas. License Digital Systems v03r01 with maximum output power.

The measured emission level of the EUT was maximized by rotating the EUT on a turntable, adjusting the orientation of the EUT and EUT antenna in three orthogonal axis (X: flat, Y: portrait, Z: landscape), and adjusting the measurement antenna orientation, following C63.26 exploratory test procedures and find <Primary Antenna>: X Plane with Adapter for EN-DC 12A-n30A; <ASDIV Antenna>: Y Plane with Adapter for EN-DC 5A-n30A as worst plane.

| Test Items | Band | Bandwidth (MHz) | | | | | | Modulation | | | | | RB # | | | Test Channel | | |
|-----------------------------|--|-----------------|---|---|----|----|----|------------|------|-------|-------|--------|------------|------|------|--------------|---|---|
| | | 1.4 | 3 | 5 | 10 | 15 | 20 | PI/2 BPSK | QPSK | 16QAM | 64QAM | 256QAM | 1 | Half | Full | L | M | H |
| Max. Output Power | n30 | - | - | v | v | - | - | v | v | v | v | v | v | v | v | v | v | v |
| Peak-to-Average Ratio | n30 | - | - | | v | - | - | v | v | v | v | v | | | v | | v | |
| E.I.R.P | n30 | - | - | v | v | - | - | v | v | v | v | v | Max. Power | | | | | |
| 26dB and 99% Bandwidth | n30 | - | - | v | v | - | - | v | v | v | v | v | | | v | | v | |
| Conducted Band Edge | n30 | - | - | v | v | - | - | v | v | v | v | v | v | | v | v | v | v |
| Conducted Spurious Emission | n30 | - | - | v | | - | - | | v | | | | v | | | v | v | v |
| Frequency Stability | n30 | - | - | | v | - | - | v | | | | | | | v | | v | |
| Radiated Spurious Emission | n30 | Worst Case | | | | | | | | | | | | | v | v | v | |
| Remark | <ol style="list-style-type: none"> The mark "v" means that this configuration is chosen for testing The mark "-" means that this bandwidth is not supported. The device is investigated from 30MHz to 10 times of fundamental signal for radiated spurious emission test under different RB size/offset and modulations in exploratory test. Subsequently, only the worst case emissions are reported. All the radiated test cases were performed with Adapter 2 and USB Cable 1. Test combination is EN-DC 12A-n30A and EN-DC 5A-n30A. For radiated measurement, pre-scanned in two modes, DFT-s OFDM and CP OFDM. The worst cases (DFT-s OFDM) were recorded in this report, and the worst modes of FR1 and LTE for simultaneous transmission were verified and compliant. During the preliminary test, both charging modes (Adapter mode and WPC Charging mode) were verified. It is determined that the adaptor mode is the worst case for official test. All the NR SA/NSA modes are evaluated conducted power to determine the worst case mode for conducted items to be reported, for RSE, the NSA mode is selected to be performed instead of SA mode based on the NR output power is similar. | | | | | | | | | | | | | | | | | |

2.2 Connection Diagram of Test System

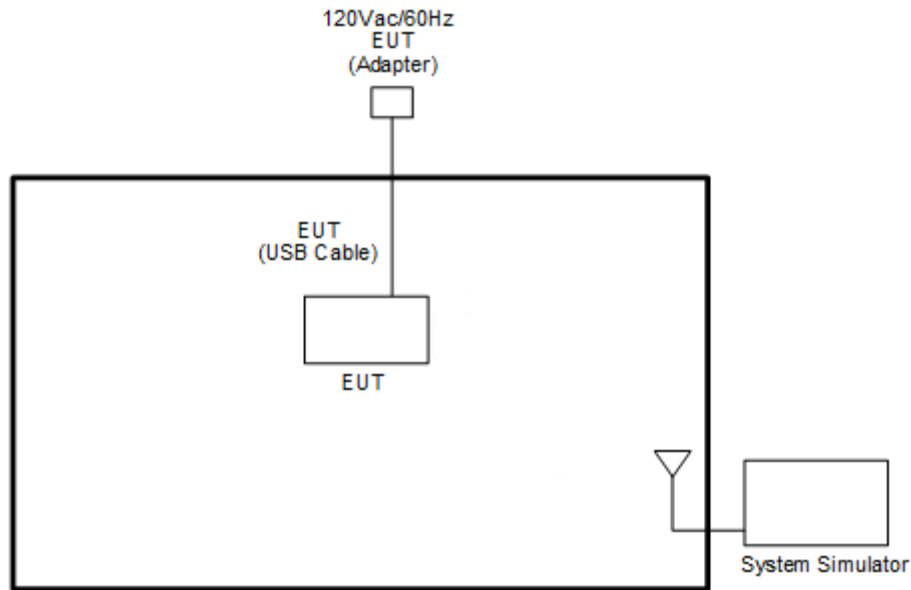

2.3 Support Unit used in test configuration and system

| Item | Equipment | Brand Name | Model No. | FCC ID | Data Cable | Power Cord |
|------|---------------------------|------------|-----------|--------|------------|-------------------|
| 1. | System Simulator | Anritsu | MT8821C | N/A | N/A | Unshielded, 1.8 m |
| 2. | 5G Wireless Test Platform | Anritsu | MT8000A | N/A | N/A | Unshielded, 1.8 m |

2.4 Measurement Results Explanation Example

For all conducted test items:

The offset level is set in the spectrum analyzer to compensate the RF cable loss and attenuator factor between EUT conducted output port and spectrum analyzer. With the offset compensation, the spectrum analyzer reading level is exactly the EUT RF output level.

The spectrum analyzer offset is derived from RF cable loss and attenuator factor.

Offset = RF cable loss + attenuator factor.

Following shows an offset computation example with cable loss 4.2 dB and 10dB attenuator.

Example :

$$\begin{aligned} \text{Offset(dB)} &= \text{RF cable loss(dB)} + \text{attenuator factor(dB)}. \\ &= 4.2 + 10 = 14.2 \text{ (dB)} \end{aligned}$$



2.5 Frequency List of Low/Middle/High Channels

| 5G NR n30 Channel and Frequency List | | | | |
|--------------------------------------|------------------------|--------|--------|---------|
| BW [MHz] | Channel/Frequency(MHz) | Lowest | Middle | Highest |
| 10 | Channel | - | 27710 | - |
| | Frequency | - | 2310 | - |
| 5 | Channel | 27685 | 27710 | 27735 |
| | Frequency | 2307.5 | 2310 | 2312.5 |

3 Conducted Test Items

3.1 Measuring Instruments

See list of measuring instruments of this test report.

3.1.1 Test Setup

3.1.2 Conducted Output Power

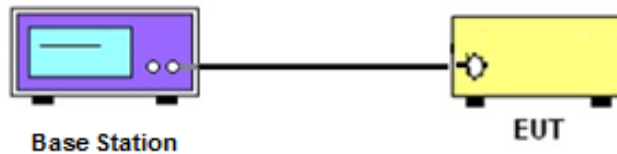

3.1.3 Peak-to-Average Ratio, Occupied Bandwidth, 26dB Bandwidth, Band-Edge and Conducted Spurious Emission

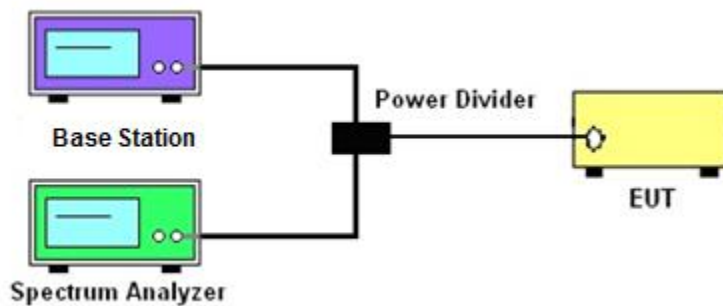

3.1.4 Frequency Stability

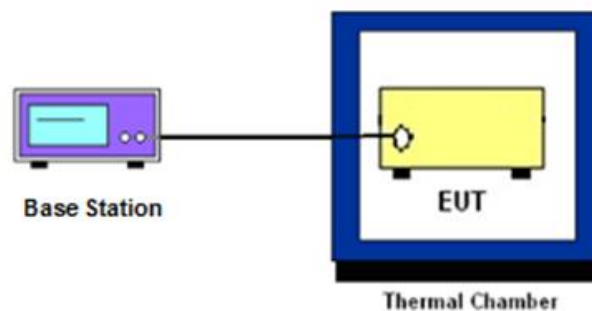

3.1.5 Test Result of Conducted Test

Please refer to Appendix A.



3.2 Conducted Output Power Measurement

3.2.1 Description of the Conducted Output Power Measurement

A base station simulator was used to establish communication with the EUT. Its parameters were set to transmit the maximum power on the EUT. The measured power in the radio frequency on the transmitter output terminals shall be reported.

3.2.2 Test Procedures

1. The transmitter output port was connected to the system simulator.
2. Set EUT at maximum power through the system simulator.
3. Select lowest, middle, and highest channels for each band and different modulation.
4. Measure and record the power level from the system simulator.



3.3 Peak-to-Average Ratio

3.3.1 Description of the PAR Measurement

Power Complementary Cumulative Distribution Function (CCDF) curves provide a means for characterizing the power peaks of a digitally modulated signal on a statistical basis. A CCDF curve depicts the probability of the peak signal amplitude exceeding the average power level. Most contemporary measurement instrumentation include the capability to produce CCDF curves for an input signal provided that the instrument's resolution bandwidth can be set wide enough to accommodate the entire input signal bandwidth. In measuring transmissions in this band using an average power technique, the peak-to-average ratio (PAR) of the transmission may not exceed 13 dB.

3.3.2 Test Procedures

The testing follows ANSI C63.26-2015 Section 5.2.6

1. The EUT was connected to spectrum and system simulator via a power divider.
2. Set the CCDF (Complementary Cumulative Distribution Function) option in spectrum analyzer.
3. The highest RF powers were measured and recorded the maximum PAPR level associated with a probability of 0.1 %.
4. Record the deviation as Peak to Average Ratio.



3.4 EIRP Power Density

3.4.1 Description of EIRP Power Density

For mobile and portable stations transmitting in the 2305-2315 MHz band or the 2350-2360 MHz band, the average EIRP must not exceed 50 milliwatts within any 1 megahertz of authorized bandwidth, *except that* for mobile and portable stations compliant with 3GPP LTE standards or another advanced mobile broadband protocol that avoids concentrating energy at the edge of the operating band the average EIRP must not exceed 250 milliwatts within any 5 megahertz of authorized bandwidth but may exceed 50 milliwatts within any 1 megahertz of authorized bandwidth. For mobile and portable stations using time division duplexing (TDD) technology, the duty cycle must not exceed 38 percent in the 2305-2315 MHz and 2350-2360 MHz bands. Mobile and portable stations using FDD technology are restricted to transmitting in the 2305-2315 MHz band. Power averaging shall not include intervals in which the transmitter is off.

Remark: EIRP use worst case measure the total power to cover per 5MHz Power.

According to KDB 412172 D01 Power Approach,

$EIRP = P_T + G_T - L_C$, where

P_T = transmitter output power in dBm

G_T = gain of the transmitting antenna in dBi

L_C = signal attenuation in the connecting cable between the transmitter and antenna in dB

3.4.2 Test Procedures

The testing follows ANSI C63.26-2015 Section 5.2.4.5

1. Determine the EIRP by adding the effective antenna gain to the adjusted power level.



3.5 Occupied Bandwidth

3.5.1 Description of Occupied Bandwidth Measurement

The occupied bandwidth is the width of a frequency band such that, below the lower and above the upper frequency limits, the mean powers emitted are each equal to a specified percentage 0.5% of the total mean transmitted power.

The 26 dB emission bandwidth is defined as the frequency range between two points, one above and one below the carrier frequency, at which the spectral density of the emission is attenuated 26 dB below the maximum in-band spectral density of the modulated signal. Spectral density (power per unit bandwidth) is to be measured with a detector of resolution bandwidth equal to approximately 1.0% of the emission bandwidth.

3.5.2 Test Procedures

The testing follows ANSI C63.26-2015 Section 5.4.3 (26dB) and Section 5.4.4 (99OB)

1. The EUT was connected to spectrum analyzer and system simulator via a power divider.
2. The spectrum analyzer center frequency is set to the nominal EUT channel center frequency. The span range for the spectrum analyzer shall be between two and five times the anticipated OBW.
3. The nominal resolution bandwidth (RBW) shall be in the range of 1 to 5 % of the anticipated OBW, and the VBW shall be at least 3 times the RBW.
4. Set the detection mode to peak, and the trace mode to max hold.
5. Determine the reference value: Set the EUT to transmit a modulated signal. Allow the trace to stabilize. Set the spectrum analyzer marker to the highest level of the displayed trace.
(this is the reference value)
6. Determine the “-26 dB down amplitude” as equal to (Reference Value – X).
7. Place two markers, one at the lowest and the other at the highest frequency of the envelope of the spectral display such that each marker is at or slightly below the “-X dB down amplitude” determined in step 6. If a marker is below this “-X dB down amplitude” value it shall be placed as close as possible to this value. The OBW is the positive frequency difference between the two markers.
8. Use the 99 % power bandwidth function of the spectrum analyzer and report the measured bandwidth.



3.6 Conducted Band Edge

3.6.1 Description of Conducted Band Edge Measurement

27.53 (a)(4)

For mobile and portable stations operating in the 2305-2315 MHz and 2350-2360 MHz bands:

- (i) By a factor of not less than: $43 + 10 \log (P)$ dB on all frequencies between 2305 and 2320 MHz and on all frequencies between 2345 and 2360 MHz that are outside the licensed band(s) of operation, not less than $55 + 10 \log (P)$ dB on all frequencies between 2320 and 2324 MHz and on all frequencies between 2341 and 2345 MHz, not less than $61 + 10 \log (P)$ dB on all frequencies between 2324 and 2328 MHz and on all frequencies between 2337 and 2341 MHz, and not less than $67 + 10 \log (P)$ dB on all frequencies between 2328 and 2337 MHz.
- (ii) By a factor of not less than $43 + 10 \log (P)$ dB on all frequencies between 2300 and 2305 MHz, $55 + 10 \log (P)$ dB on all frequencies between 2296 and 2300 MHz, $61 + 10 \log (P)$ dB on all frequencies between 2292 and 2296 MHz, $67 + 10 \log (P)$ dB on all frequencies between 2288 and 2292 MHz, and $70 + 10 \log (P)$ dB below 2288 MHz.
- (iii) By a factor of not less than $43 + 10 \log (P)$ dB on all frequencies between 2360 and 2365 MHz, and not less than $70 + 10 \log (P)$ dB above 2365 MHz.

3.6.2 Test Procedures

The testing follows FCC KDB 971168 D01 v03r01 Section 6.1.

1. The EUT was connected to spectrum analyzer and system simulator via a power divider.
2. The band edges of low and high channels for the highest RF powers were measured.
3. Set RBW \geq 1% EBW in the 1MHz band immediately outside and adjacent to the band edge.
4. Beyond the 1 MHz band from the band edge, RBW=1MHz was used.
5. Set spectrum analyzer with RMS detector.
6. The RF fundamental frequency should be excluded against the limit line in the operating frequency band.
7. Checked that all the results comply with the emission limit line.

The limit line is derived from $43 + 10\log(P)$ dB below the transmitter power P(Watts)



3.7 Conducted Spurious Emission

3.7.1 Description of Conducted Spurious Emission Measurement

The power of any emission outside of the authorized operating frequency ranges must be lower than the transmitter power (P) by a factor of at least $70 + 10 \log (P)$ dB.

It is measured by means of a calibrated spectrum analyzer and scanned from 9 kHz up to a frequency including its 10th harmonic.

3.7.2 Test Procedures

The testing follows FCC KDB 971168 D01 v03r01 Section 6.1.

1. The EUT was connected to spectrum analyzer and system simulator via a power divider.
2. The RF output of EUT was connected to the spectrum analyzer by RF cable and attenuator. The path loss was compensated to the results for each measurement.
3. The middle channel for the highest RF power within the transmitting frequency was measured.
4. The conducted spurious emission for the whole frequency range was taken.
5. Make the measurement with the spectrum analyzer's RBW = 1MHz, VBW = 3MHz.
6. Set spectrum analyzer with RMS detector.
7. Taking the record of maximum spurious emission.
8. The RF fundamental frequency should be excluded against the limit line in the operating frequency band.
9. The limit line is derived from $70 + 10\log(P)$ dB below the transmitter power P(Watts)



3.8 Frequency Stability

3.8.1 Description of Frequency Stability Measurement

The frequency stability shall be sufficient to ensure that the fundamental emission stays within the authorized frequency block.

3.8.2 Test Procedures for Temperature Variation

The testing follows FCC KDB 971168 D01 v03r01 Section 9.0.

1. The EUT was set up in the thermal chamber and connected with the system simulator.
2. With power OFF, the temperature was decreased to -30°C and the EUT was stabilized before testing. Power was applied and the maximum change in frequency was recorded within one minute.
3. With power OFF, the temperature was raised in 10°C step up to 50°C. The EUT was stabilized at each step for at least half an hour. Power was applied and the maximum frequency change was recorded within one minute.

3.8.3 Test Procedures for Voltage Variation

The testing follows FCC KDB 971168 D01 v03r01 Section 9.0.

1. The EUT was placed in a temperature chamber at 20±5° C and connected with the system simulator.
2. The power supply voltage to the EUT was varied from 85% to 115% of the nominal value measured at the input to the EUT.
3. The variation in frequency was measured for the worst case.

4 Radiated Test Items

4.1 Measuring Instruments

See list of measuring instruments of this test report.

4.1.1 Test Setup

For radiated test below 30MHz



For radiated test from 30MHz to 1GHz



For radiated test from 1GHz to 18GHz

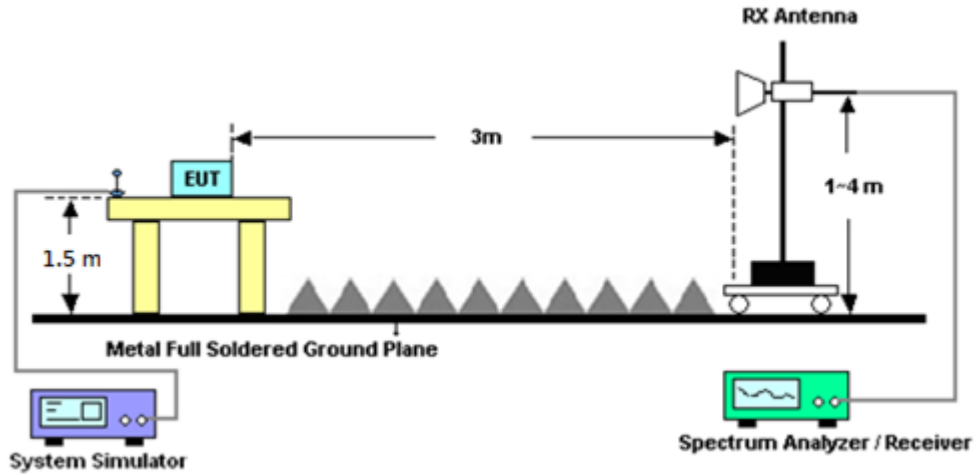

For radiated test above 18GHz

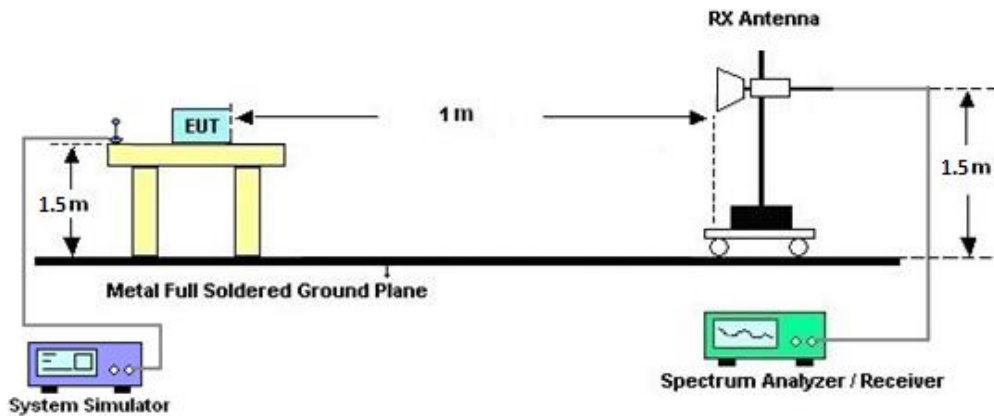

4.1.2 Test Result of Radiated Test

Please refer to Appendix B.

Note:

The low frequency, which started from 9 kHz to 30MHz, was pre-scanned and the result which was 20dB lower than the limit line was not reported.

There is adequate comparison measurement of both open-field test site and alternative test site - semi-Anechoic chamber according to 414788 D01 Radiated Test Site v01r01, and the result came out very similar.



4.2 Radiated Spurious Emission Measurement

4.2.1 Description of Radiated Spurious Emission Measurement

The radiated spurious emission was measured by substitution method according to ANSI / TIA-603-E
The power of any emission outside of the authorized operating frequency ranges must be attenuated below the transmitter power (P) by a factor of at least $70 + 10 \log (P)$ dB.
The spectrum is scanned from 30 MHz up to a frequency including its 10th harmonic.

4.2.2 Test Procedures

The testing follows FCC KDB 971168 D01 v03r01 Section 7 and ANSI / TIA-603-E Section 2.2.12.

1. The EUT was placed on a turntable with 0.8 meter height for frequency below 1GHz and 1.5 meter height for frequency above 1GHz respectively above ground.
2. The EUT was set 3 meters from the receiving antenna mounted on the antenna tower.
3. The table was rotated 360 degrees to determine the position of the highest spurious emission.
4. The height of the receiving antenna is varied between 1m to 4m to search the maximum spurious emission for both horizontal and vertical polarizations.
5. During the measurement, the system simulator parameters were set to force the EUT transmitting at maximum output power.
6. Make the measurement with the spectrum analyzer's RBW = 1MHz, VBW = 3MHz, taking the record of maximum spurious emission.
7. A horn antenna was substituted in place of the EUT and was driven by a signal generator.
8. Tune the output power of signal generator to the same emission level with EUT maximum spurious emission.
$$\text{EIRP (dBm)} = \text{S.G. Power} - \text{Tx Cable Loss} + \text{Tx Antenna Gain}$$
$$\text{ERP (dBm)} = \text{EIRP} - 2.15$$
9. The RF fundamental frequency should be excluded against the limit line in the operating frequency band.
The limit line is derived from $70 + 10\log(P)$ dB below the transmitter power P(Watts)
$$= P(\text{W}) - [70 + 10\log(P)] (\text{dB})$$
$$= [30 + 10\log(P)] (\text{dBm}) - [70 + 10\log(P)] (\text{dB})$$
$$= -40\text{dBm}.$$



5 List of Measuring Equipment

| Instrument | Brand Name | Model No. | Serial No. | Characteristics | Calibration Date | Test Date | Due Date | Remark |
|-------------------------|----------------------------|--------------------------------------|-----------------|-----------------------------|------------------|---------------------------------|---------------|--------------------------|
| Loop Antenna | Rohde & Schwarz | HFH2-Z2 | 100315 | 9 kHz~30 MHz | Jan. 04, 2021 | Jun. 16, 2021~ Jul. 09, 2021 | Jan. 03, 2022 | Radiation (03CH12-HY) |
| Bilog Antenna | TESEQ | CBL 6111D & 00800N1D01 N-06 | 37059 & 01 | 30MHz~1GHz | Oct. 11, 2020 | Jun. 16, 2021~ Jul. 09, 2021 | Oct. 10, 2021 | Radiation (03CH12-HY) |
| Horn Antenna | SCHWARZBE CK | BBHA 9120 D | 9120D-132 8 | 1GHz~18GHz | Nov. 23, 2020 | Jun. 16, 2021~ Jul. 09, 2021 | Nov. 22, 2021 | Radiation (03CH12-HY) |
| Horn Antenna | SCHWARZBE CK | BBHA 9120 D | 9120D-121 2 | 1GHz~18GHz | May 05, 2021 | Jun. 16, 2021~ Jul. 09, 2021 | May 04, 2022 | Radiation (03CH12-HY) |
| SHF-EHF Horn Antenna | SCHWARZBE CK | BBHA 9170 | 00993 | 18GHz~40GHz | Nov. 19, 2020 | Jun. 16, 2021~ Jul. 09, 2021 | Nov. 18, 2021 | Radiation (03CH12-HY) |
| SHF-EHF Horn Antenna | SCHWARZBE CK | BBHA 9170 | BBHA9170 576 | 18GHz~40GHz | May 21, 2021 | Jun. 16, 2021~ Jul. 09, 2021 | May 20, 2022 | Radiation (03CH12-HY) |
| Preamplifier | COM-POWER | PA-103 | 161075 | 10MHz~1GHz | Mar. 24, 2021 | Jun. 16, 2021~ Jul. 09, 2021 | Mar. 23, 2022 | Radiation (03CH12-HY) |
| Preamplifier | Keysight | 83017A | MY572801 20 | 1GHz~26.5GHz | Jul. 20, 2020 | Jun. 16, 2021~ Jul. 09, 2021 | Jul. 19, 2021 | Radiation (03CH12-HY) |
| Preamplifier | E-INSTRUME NT TECH LTD. | ERA-100M-18 G-56-01-A70 | EC190024 9 | 1GHz-18GHz | Dec. 05, 2020 | Jun. 16, 2021~ Jul. 09, 2021 | Dec. 04, 2021 | Radiation (03CH12-HY) |
| Preamplifier | EMEC | EM18G40G | 060715 | 18GHz~40GHz | Dec. 11, 2020 | Jun. 16, 2021~ Jul. 09, 2021 | Dec. 10, 2021 | Radiation (03CH12-HY) |
| Spectrum Analyzer | Agilent | N9010A | MY534701 18 | 10Hz~44GHz | Jan. 15, 2021 | Jun. 16, 2021~ Jul. 09, 2021 | Jan. 14, 2022 | Radiation (03CH12-HY) |
| RF Cable | HUBER + SUHNER | SUCOFLEX 104 | MY9837/4 PE | 9kHz~30MHz | Mar. 11, 2021 | Jun. 16, 2021~ Jul. 09, 2021 | Mar. 10, 2022 | Radiation (03CH12-HY) |
| RF Cable | HUBER + SUHNER | SUCOFLEX 126E | 0058/126E | 30MHz~18GHz | Dec. 11, 2020 | Jun. 16, 2021~ Jul. 09, 2021 | Dec. 10, 2021 | Radiation (03CH12-HY) |
| RF Cable | HUBER + SUHNER | SUCOFLEX 102 | 505134/2 | 30MHz~40GHz | Feb. 22, 2021 | Jun. 16, 2021~ Jul. 09, 2021 | Feb. 21, 2022 | Radiation (03CH12-HY) |
| RF Cable | HUBER + SUHNER | SUCOFLEX 102 | 800740/2 | 30MHz~40GHz | Feb. 22, 2021 | Jun. 16, 2021~ Jul. 09, 2021 | Feb. 21, 2022 | Radiation (03CH12-HY) |
| Antenna Mast | EMEC | AM-BS-4500- B | N/A | 1m~4m | N/A | Jun. 16, 2021~ Jul. 09, 2021 | N/A | Radiation (03CH12-HY) |
| Turn Table | EMEC | TT2000 | N/A | 0~360 Degree | N/A | Jun. 16, 2021~ Jul. 09, 2021 | N/A | Radiation (03CH12-HY) |
| Software | Audix | E3 6.2009-8-24 | RK-00098 9 | N/A | N/A | Jun. 16, 2021~ Jul. 09, 2021 | N/A | Radiation (03CH12-HY) |
| Filter | Wainwright | WLKS1200-1 2SS | SN2 | 1.2GHz Low Pass Filter | Mar. 17, 2021 | Jun. 16, 2021~ Jul. 09, 2021 | Mar. 16, 2022 | Radiation (03CH12-HY) |
| Filter | Wainwright | WHKX12-270 0-3000-18000 -60ST | SN2 | 3GHz High Pass Filter | Jul. 14, 2020 | Jun. 16, 2021~ Jul. 09, 2021 | Jul. 13, 2021 | Radiation (03CH12-HY) |
| Filter | Wainwright | WHKX8-5872. 5-6750-18000 -40ST | SN2 | 6.75GHz High Pass Filter | Mar. 17, 2021 | Jun. 16, 2021~ Jul. 09, 2021 | Mar. 16, 2022 | Radiation (03CH12-HY) |



| Instrument | Brand Name | Model No. | Serial No. | Characteristics | Calibration Date | Test Date | Due Date | Remark |
|---------------------------|-----------------|-----------|----------------|-----------------|------------------|---------------------------------|---------------|---------------------|
| Programmable Power Supply | GW Instek | PSS-2005 | EL890001 | 50Hz~60Hz | Oct. 05, 2020 | Jun. 08, 2021~ Jul. 15, 2021 | Oct. 04, 2021 | Conducted (TH03-HY) |
| Signal Analyzer | Rohde & Schwarz | FSV3044 | 101048 | 10Hz~44GHz | Apr. 20, 2021 | Jun. 08, 2021~ Jul. 15, 2021 | Apr. 19, 2022 | Conducted (TH03-HY) |
| Temperature Chamber | ESPEC | SU-241 | 92003713 | -30℃ ~95℃ | May 21, 2021 | Jun. 08, 2021~ Jul. 15, 2021 | May 20, 2022 | Conducted (TH03-HY) |
| Hygrometer | Testo | 608-H11 | 3489324 | NA | Jan. 18, 2021 | Jun. 08, 2021~ Jul. 15, 2021 | Jan. 17, 2022 | Conducted (TH03-HY) |
| Base Station (Measure) | Anritsu | MT8821C | 626184901 5 | LTE | Sep. 18, 2020 | Jun. 08, 2021~ Jul. 15, 2021 | Sep. 17, 2021 | Conducted (TH03-HY) |
| Base Station (Measure) | Anritsu | MT8000A | 626194032 7 | FR1 | Sep. 23, 2020 | Jun. 08, 2021~ Jul. 15, 2021 | Sep. 22, 2021 | Conducted (TH03-HY) |



6 Uncertainty of Evaluation

Uncertainty of Radiated Emission Measurement (1 GHz ~ 18 GHz)

| | |
|---|---------|
| Measuring Uncertainty for a Level of Confidence of 95% ($U = 2Uc(y)$) | 3.10 dB |
|---|---------|

Uncertainty of Radiated Emission Measurement (1 GHz ~ 18 GHz)

| | |
|---|---------|
| Measuring Uncertainty for a Level of Confidence of 95% ($U = 2Uc(y)$) | 3.39 dB |
|---|---------|

Uncertainty of Radiated Emission Measurement (18 GHz ~ 40 GHz)

| | |
|---|---------|
| Measuring Uncertainty for a Level of Confidence of 95% ($U = 2Uc(y)$) | 4.34 dB |
|---|---------|



Appendix A. Test Results of Conducted Test

Conducted Output Power(Average power and EIRP)

<Primary Antenna>

| NR n30 Maximum Average Power [dBm] (GT - LC = -1.7 dB) | | | | | | | | | | |
|--|--------------------|-----------|-----------|--------|--------|---------|------------|---------|-------|--------|
| BW [MHz] | RB Size | RB Offset | Mod | Lowest | Middle | Highest | EIRP (dBm) | EIRP(W) | | |
| 5 | 1 | 1 | PI/2 BPSK | 24.42 | 24.45 | 24.53 | 22.85 | 0.1928 | | |
| 5 | 1 | 23 | | 24.43 | 24.43 | 24.55 | | | | |
| 5 | 12 | 6 | | 24.36 | 24.38 | 24.53 | | | | |
| 5 | 1 | 0 | | 23.93 | 23.94 | 24.05 | | | | |
| 5 | 1 | 24 | | 23.91 | 23.96 | 24.07 | | | | |
| 5 | 25 | 0 | | 23.90 | 23.92 | 24.05 | | | | |
| 5 | 1 | 1 | QPSK | 24.37 | 24.40 | 24.48 | | | 21.92 | 0.1556 |
| 5 | 1 | 23 | | 24.36 | 24.41 | 24.49 | | | | |
| 5 | 12 | 6 | | 24.38 | 24.41 | 24.51 | | | | |
| 5 | 1 | 0 | | 23.39 | 23.42 | 23.55 | | | | |
| 5 | 1 | 24 | | 23.41 | 23.48 | 23.46 | | | | |
| 5 | 25 | 0 | | 23.42 | 23.43 | 23.54 | | | | |
| 5 | 1 | 1 | 16-QAM | 23.15 | 23.45 | 23.62 | 21.92 | 0.1556 | | |
| 5 | 1 | 1 | 64-QAM | 21.94 | 21.99 | 21.77 | | | | |
| 5 | 1 | 1 | 256-QAM | 19.86 | 19.93 | 20.02 | | | | |
| Limit | EIRP < 250 mW/5MHz | | | Result | | | Pass | | | |

| NR n30 Maximum Average Power [dBm] (GT - LC = -1.7 dB) | | | | | | | | | | |
|--|--------------------|-----------|-----------|--------|--------|---------|------------|---------|-------|--------|
| BW [MHz] | RB Size | RB Offset | Mod | Lowest | Middle | Highest | EIRP (dBm) | EIRP(W) | | |
| 10 | 1 | 1 | PI/2 BPSK | - | 24.43 | - | 22.73 | 0.1875 | | |
| 10 | 1 | 50 | | - | 24.41 | - | | | | |
| 10 | 25 | 12 | | - | 24.39 | - | | | | |
| 10 | 1 | 0 | | - | 23.95 | - | | | | |
| 10 | 1 | 51 | | - | 23.94 | - | | | | |
| 10 | 50 | 0 | | - | 23.89 | - | | | | |
| 10 | 1 | 1 | QPSK | - | 24.37 | - | | | 21.63 | 0.1455 |
| 10 | 1 | 50 | | - | 24.34 | - | | | | |
| 10 | 25 | 12 | | - | 24.39 | - | | | | |
| 10 | 1 | 0 | | - | 23.38 | - | | | | |
| 10 | 1 | 51 | | - | 23.42 | - | | | | |
| 10 | 50 | 0 | | - | 23.40 | - | | | | |
| 10 | 1 | 1 | 16-QAM | - | 23.33 | - | 21.63 | 0.1455 | | |
| 10 | 1 | 1 | 64-QAM | - | 22.06 | - | | | | |
| 10 | 1 | 1 | 256-QAM | - | 20.04 | - | | | | |
| Limit | EIRP < 250 mW/5MHz | | | Result | | | Pass | | | |



<ASDIV Antenna>

| NR n30 Maximum Average Power [dBm] (GT - LC = -1.4 dB) | | | | | | | | |
|--|--------------------|-----------|-----------|--------|--------|---------|------------|---------|
| BW [MHz] | RB Size | RB Offset | Mod | Lowest | Middle | Highest | EIRP (dBm) | EIRP(W) |
| 5 | 1 | 1 | PI/2 BPSK | 24.22 | 24.25 | 24.29 | 22.96 | 0.1977 |
| 5 | 1 | 23 | | 24.19 | 24.23 | 24.36 | | |
| 5 | 12 | 6 | | 24.16 | 24.22 | 24.30 | | |
| 5 | 1 | 0 | | 23.77 | 23.77 | 23.85 | | |
| 5 | 1 | 24 | | 23.72 | 23.77 | 23.91 | | |
| 5 | 25 | 0 | | 23.71 | 23.64 | 23.71 | | |
| 5 | 1 | 1 | QPSK | 24.19 | 24.22 | 24.25 | | |
| 5 | 1 | 23 | | 24.16 | 24.16 | 24.25 | | |
| 5 | 12 | 6 | | 24.16 | 24.23 | 24.31 | | |
| 5 | 1 | 0 | | 23.14 | 23.22 | 23.40 | | |
| 5 | 1 | 24 | | 23.26 | 23.27 | 23.25 | | |
| 5 | 25 | 0 | | 23.25 | 23.19 | 23.22 | | |
| 5 | 1 | 1 | 16-QAM | 23.15 | 23.31 | 23.31 | 21.91 | 0.1552 |
| 5 | 1 | 1 | 64-QAM | 21.66 | 21.66 | 21.93 | | |
| 5 | 1 | 1 | 256-QAM | 19.79 | 19.85 | 19.94 | | |
| Limit | EIRP < 250 mW/5MHz | | | Result | | | Pass | |

| NR n30 Maximum Average Power [dBm] (GT - LC = -1.4 dB) | | | | | | | | |
|--|--------------------|-----------|-----------|--------|--------|---------|------------|---------|
| BW [MHz] | RB Size | RB Offset | Mod | Lowest | Middle | Highest | EIRP (dBm) | EIRP(W) |
| 10 | 1 | 1 | PI/2 BPSK | - | 24.30 | - | 22.90 | 0.1950 |
| 10 | 1 | 50 | | - | 24.29 | - | | |
| 10 | 25 | 12 | | - | 24.22 | - | | |
| 10 | 1 | 0 | | - | 23.84 | - | | |
| 10 | 1 | 51 | | - | 23.83 | - | | |
| 10 | 50 | 0 | | - | 23.73 | - | | |
| 10 | 1 | 1 | QPSK | - | 24.25 | - | | |
| 10 | 1 | 50 | | - | 24.19 | - | | |
| 10 | 25 | 12 | | - | 24.22 | - | | |
| 10 | 1 | 0 | | - | 23.29 | - | | |
| 10 | 1 | 51 | | - | 23.24 | - | | |
| 10 | 50 | 0 | | - | 23.22 | - | | |
| 10 | 1 | 1 | 16-QAM | - | 23.39 | - | 21.99 | 0.1581 |
| 10 | 1 | 1 | 64-QAM | - | 21.87 | - | | |
| 10 | 1 | 1 | 256-QAM | - | 19.77 | - | | |
| Limit | EIRP < 250 mW/5MHz | | | Result | | | Pass | |



FR1 n30

Peak-to-Average Ratio

| Mode | FR1 n30 / 10MHz / DFT-S OFDM | | | | |
|-----------|------------------------------|---------|---------|---------|-------------|
| Mod. | PI/2 BPSK | QPSK | 16QAM | 64QAM | Limit: 13dB |
| RB Size | Full RB | Full RB | Full RB | Full RB | Result |
| Middle CH | 4.62 | 5.80 | 6.38 | 6.60 | PASS |
| Mode | FR1 n30 / 10MHz / DFT-S OFDM | | | | |
| Mod. | 256QAM | | | | Limit: 13dB |
| RB Size | Full RB | | | | Result |
| Middle CH | 6.92 | | | | PASS |



FR1 n30 / 10MHz / DFT-S OFDM / Middle Channel / Full RB

PI/2 BPSK

QPSK

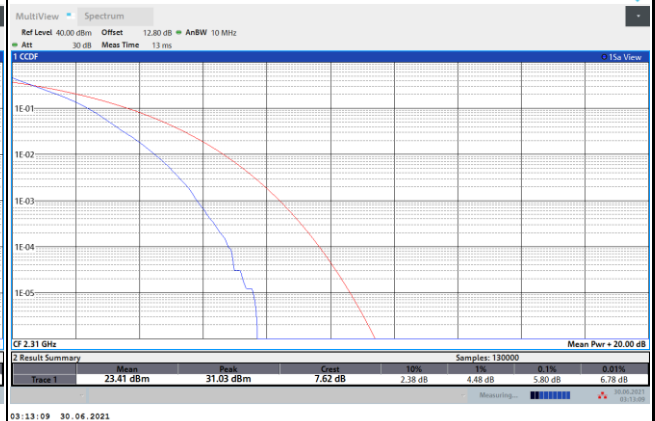
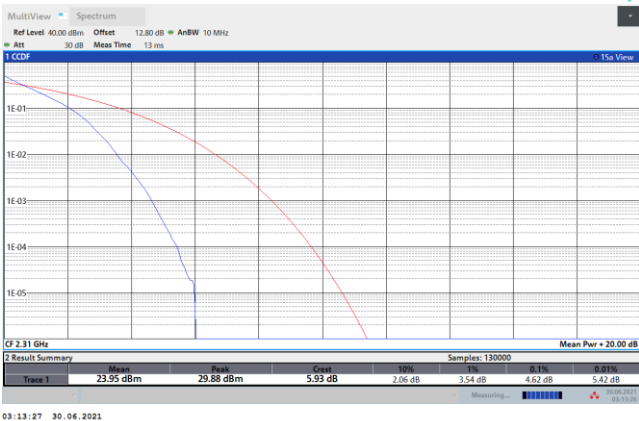

16QAM

64QAM

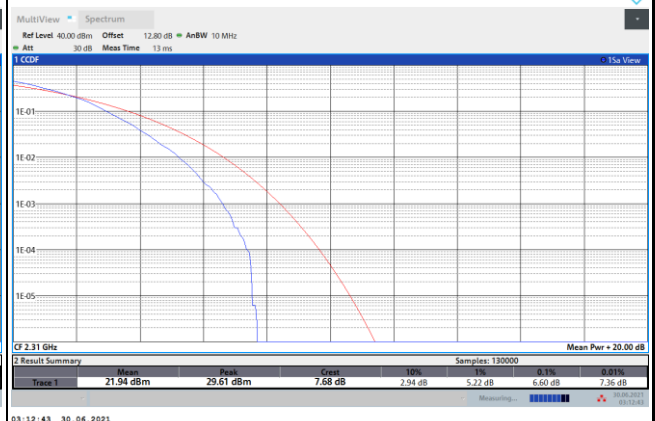
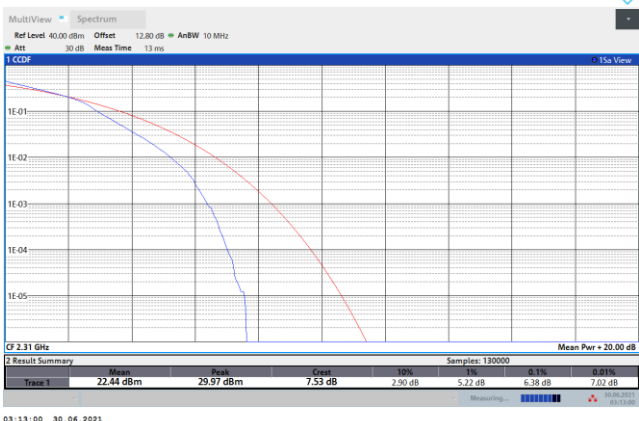

256QAM

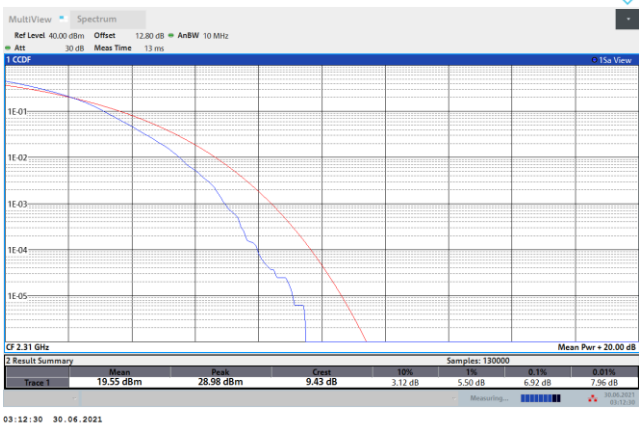



26dB Bandwidth

| Mode | FR1 n30 : 26dB BW(MHz) / DFT-S OFDM | | | | | | | |
|-----------|-------------------------------------|--|-----------|--|--|--|--|--|
| BW | 5MHz | | 10MHz | | | | | |
| Mod. | PI/2 BPSK | | PI/2 BPSK | | | | | |
| Middle CH | 5.14 | | 9.55 | | | | | |

| Mode | FR1 n30 : 26dB BW(MHz) / CP OFDM | | | | | | | |
|-----------|----------------------------------|--------|-------|--------|--|--|--|--|
| BW | 5MHz | | 10MHz | | | | | |
| Mod. | QPSK | 16QAM | QPSK | 16QAM | | | | |
| Middle CH | 5.15 | 4.93 | 10.07 | 9.81 | | | | |
| Mod. | 64QAM | 256QAM | 64QAM | 256QAM | | | | |
| Middle CH | 5.01 | 5.01 | 10.07 | 10.03 | | | | |



FR1 n30 / 5MHz / DFT-S OFDM / Middle Channel / Full RB

PI/2 BPSK

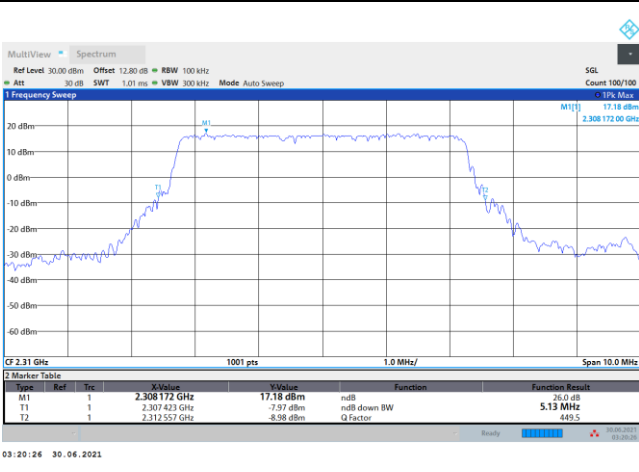

FR1 n30 / 5MHz / CP OFDM / Middle Channel / Full RB

QPSK

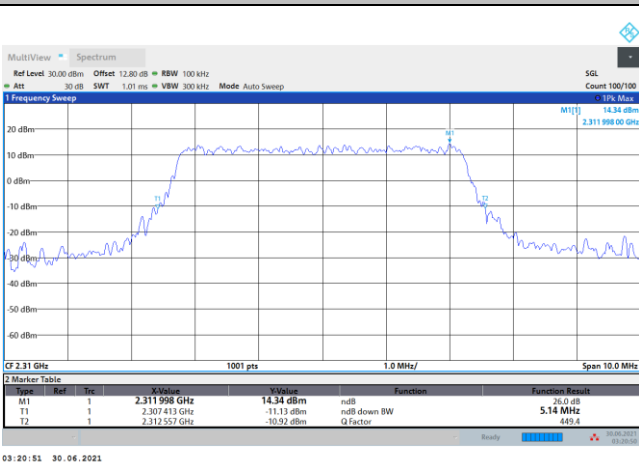

16QAM

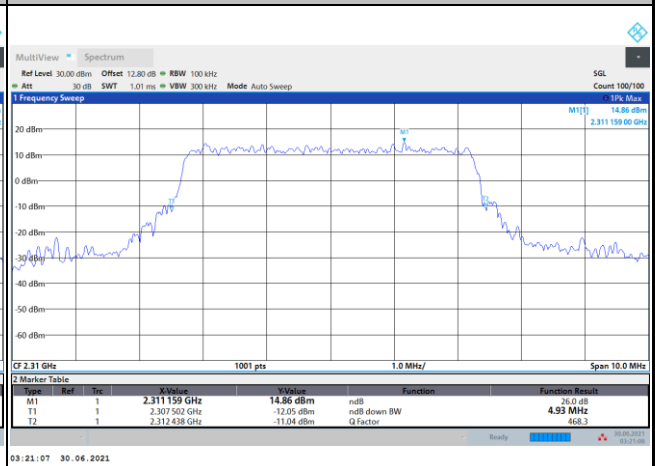

64QAM

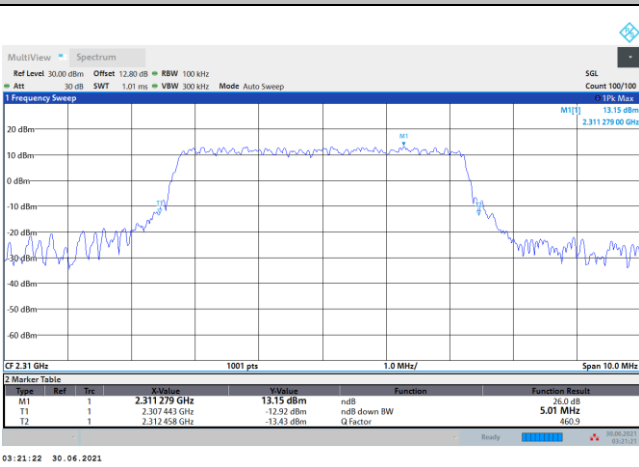

256QAM

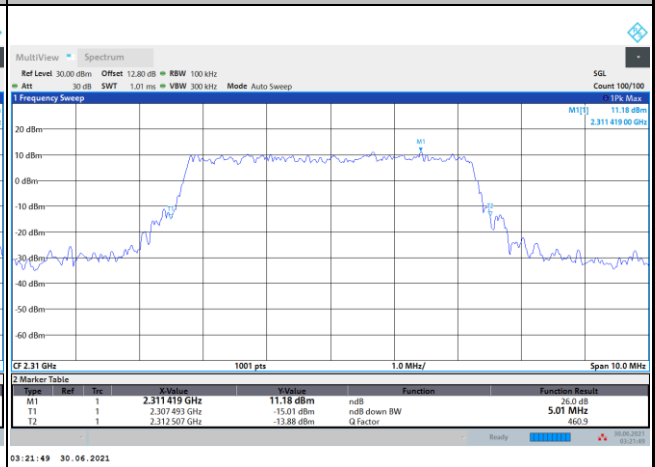



FR1 n30 / 10MHz / DFT-S OFDM / Middle Channel / Full RB

PI/2 BPSK

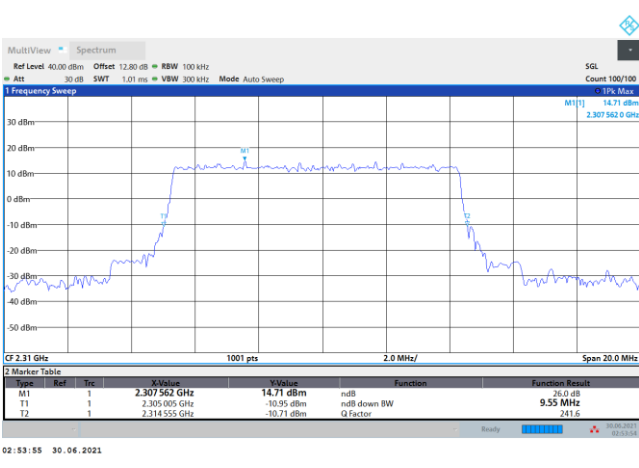

FR1 n30 / 10MHz / CP OFDM / Middle Channel / Full RB

QPSK

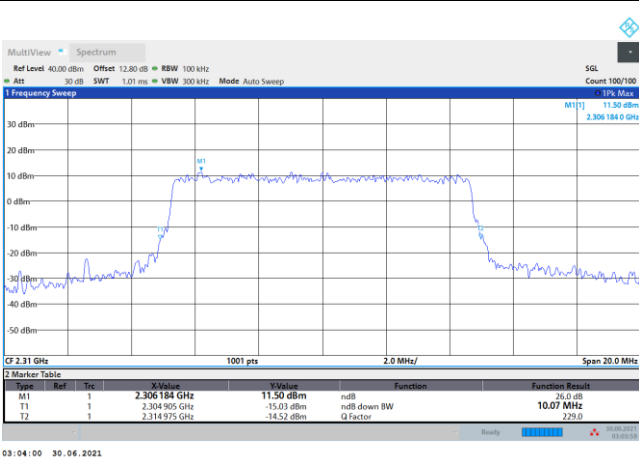

16QAM

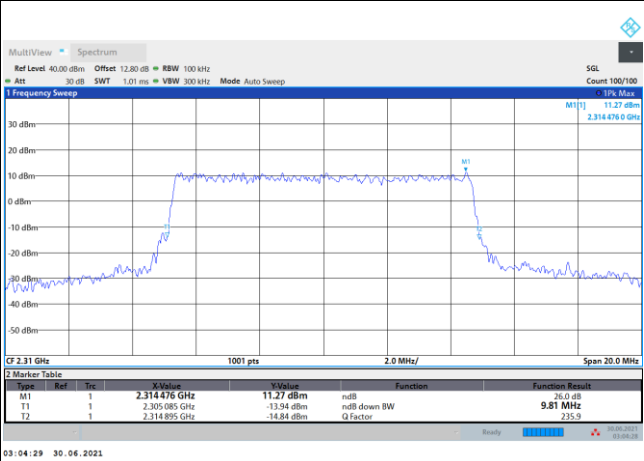

64QAM

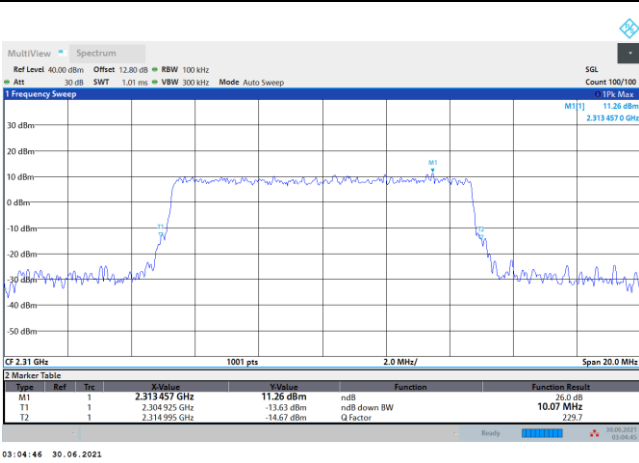

256QAM

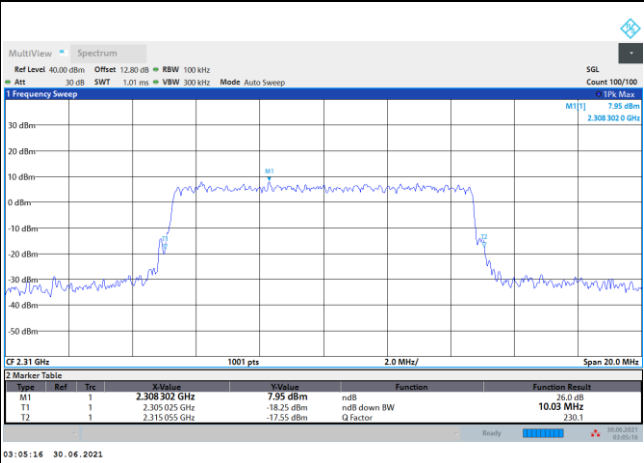



Occupied Bandwidth

| Mode | FR1 n30 : 99%OBW(MHz) / DFT-S OFDM | | | | | | | |
|-----------|------------------------------------|--|-----------|--|--|--|--|--|
| BW | 5MHz | | 10MHz | | | | | |
| Mod. | PI/2 BPSK | | PI/2 BPSK | | | | | |
| Middle CH | 4.47 | | 8.92 | | | | | |

| Mode | FR1 n30 : 99%OBW (MHz) / CP OFDM | | | | | | | |
|-----------|----------------------------------|--------|-------|--------|--|--|--|--|
| BW | 5MHz | | 10MHz | | | | | |
| Mod. | QPSK | 16QAM | QPSK | 16QAM | | | | |
| Middle CH | 4.50 | 4.50 | 9.29 | 9.32 | | | | |
| Mod. | 64QAM | 256QAM | 64QAM | 256QAM | | | | |
| Middle CH | 4.51 | 4.53 | 9.29 | 9.30 | | | | |



FR1 n30 / 5MHz / DFT-S OFDM / Middle Channel / Full RB

PI/2 BPSK

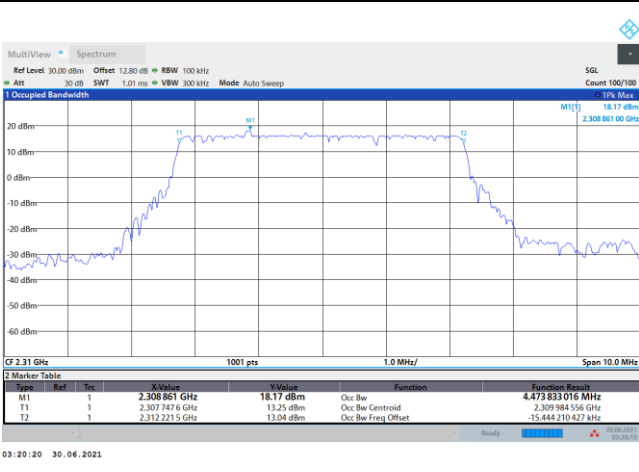

FR1 n30 / 5MHz / CP OFDM / Middle Channel / Full RB

QPSK

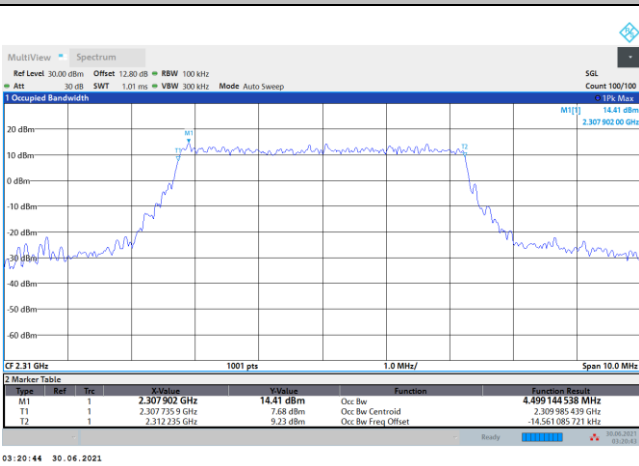

16QAM

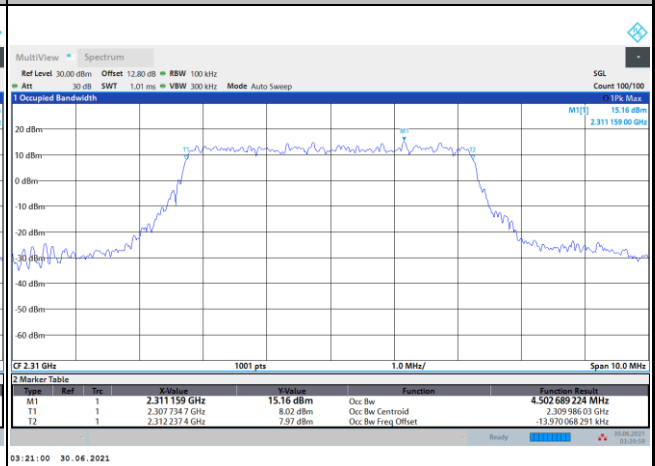

64QAM

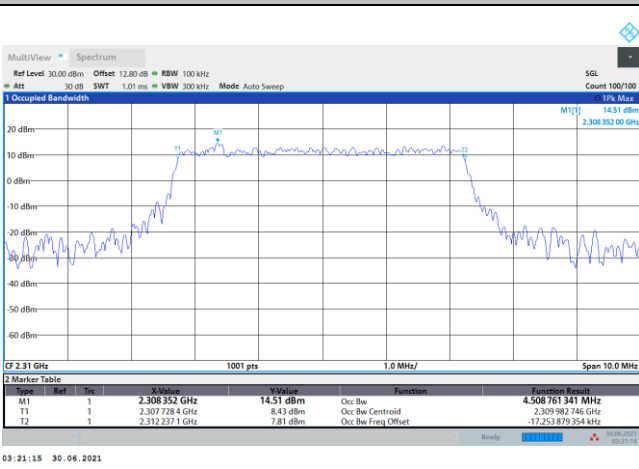

256QAM

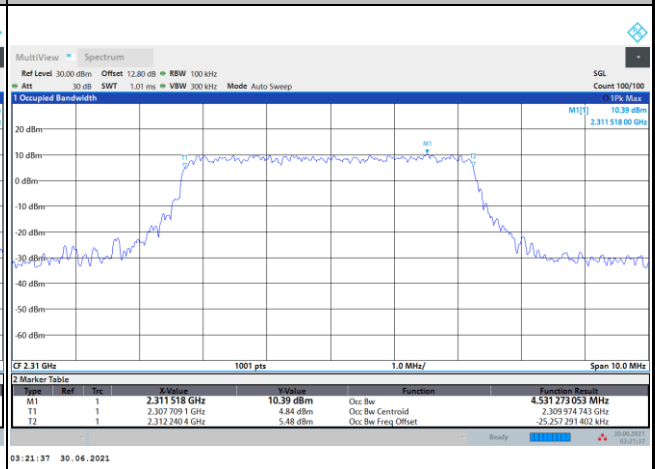



FR1 n30 / 10MHz / DFT-S OFDM / Middle Channel / Full RB

PI/2 BPSK

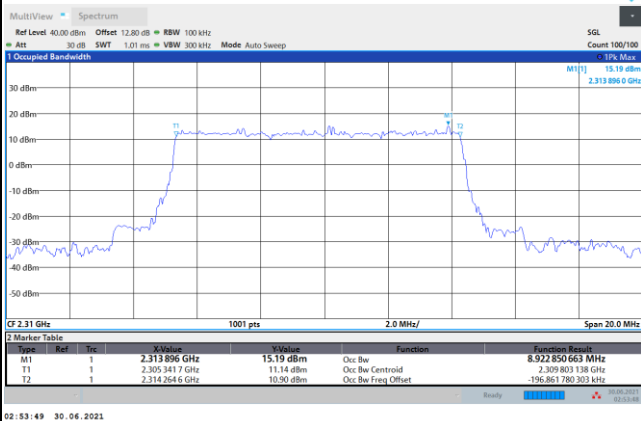

FR1 n30 / 10MHz / CP OFDM / Middle Channel / Full RB

QPSK

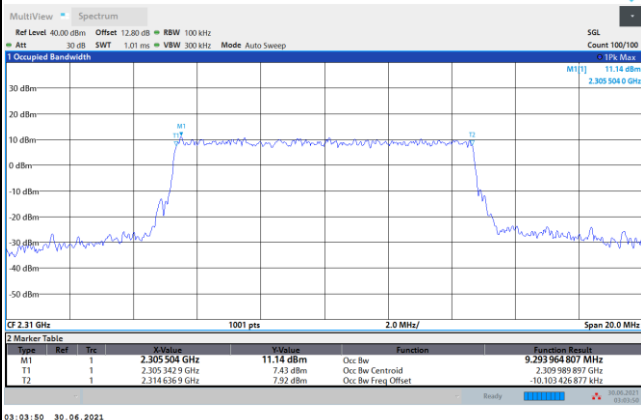

16QAM

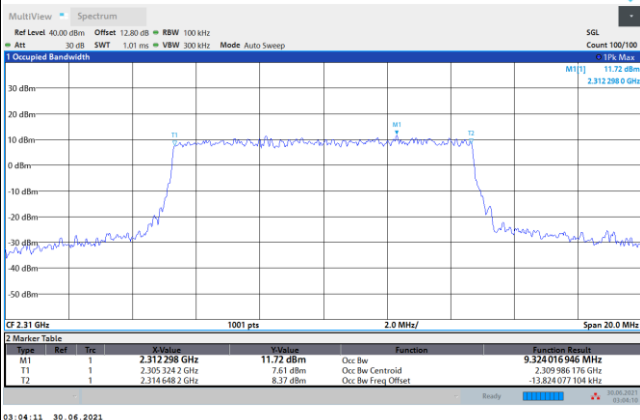

64QAM

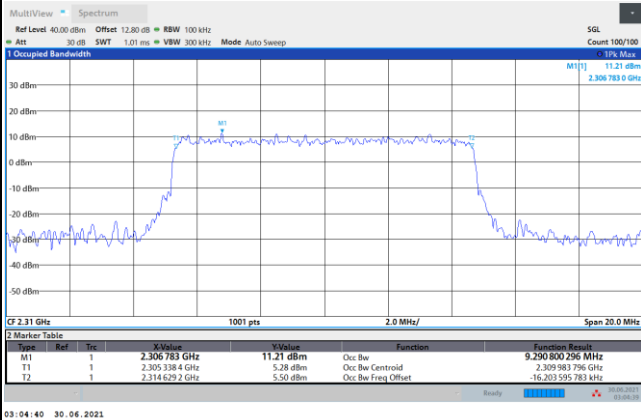

256QAM

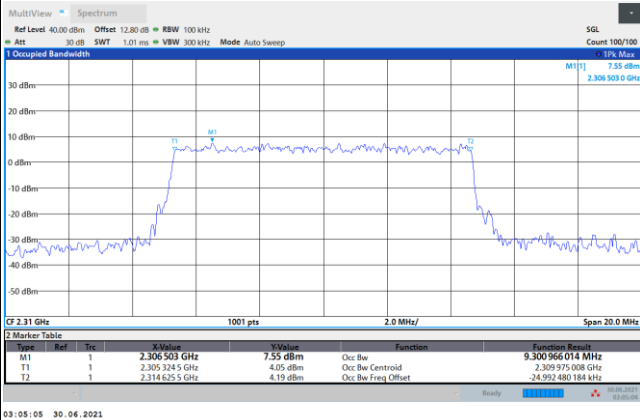



Conducted Band Edge

FR1 n30 / 5MHz / DFT-S OFDM / PI/2 BPSK

Lowest Band Edge / 1RB0

Highest Band Edge / 1RBmax

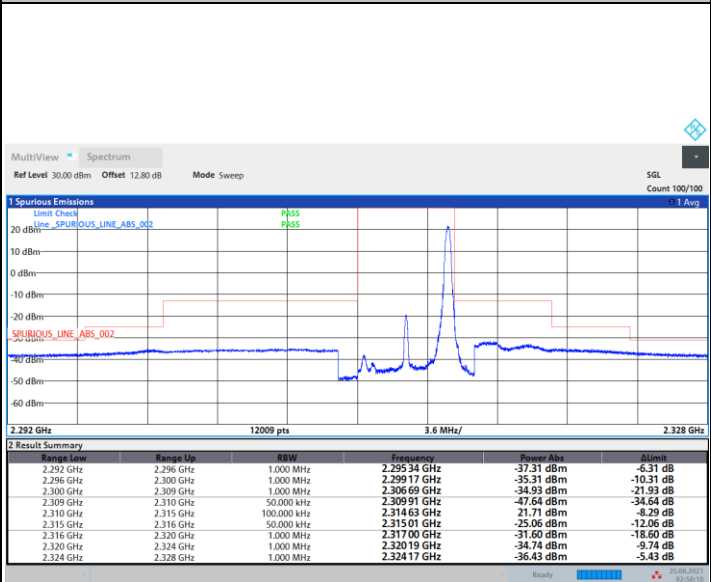
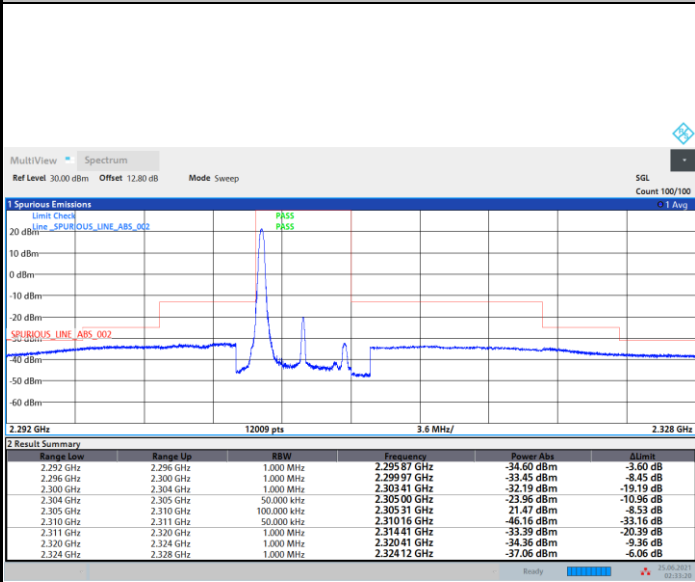

Lowest Band Edge / Full RB

Highest Band Edge / Full RB

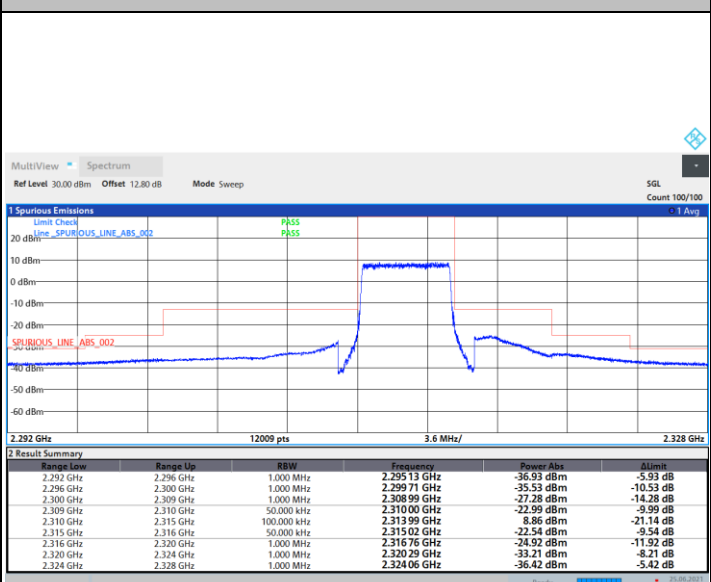
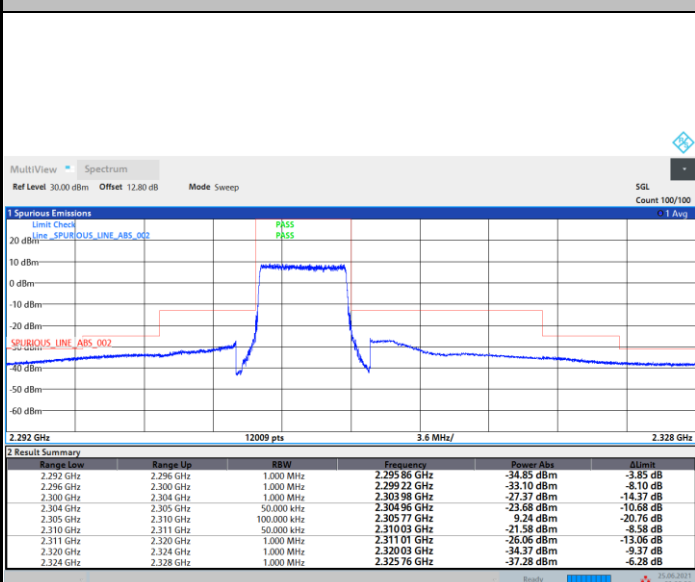



FR1 n30 / 5MHz / DFT-S OFDM / QPSK

Lowest Band Edge / 1RB0

Highest Band Edge / 1RBmax

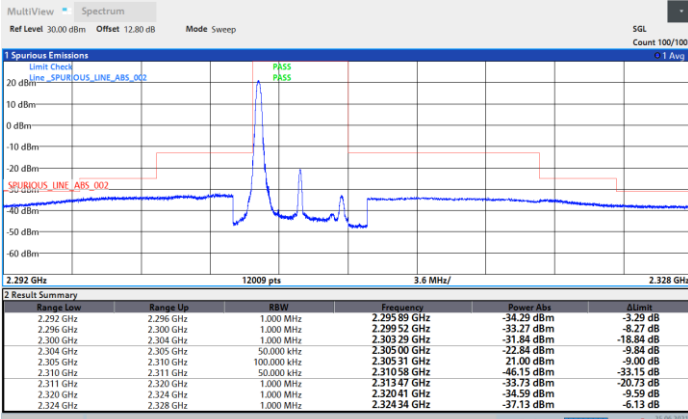

02:33:04 25.06.2021

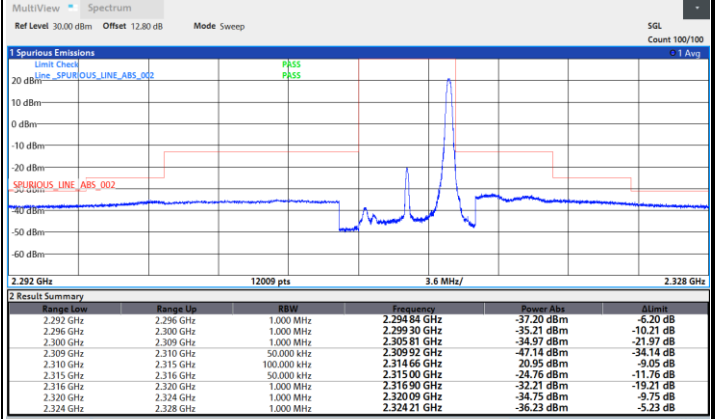

02:49:55 25.06.2021

Lowest Band Edge / Full RB

Highest Band Edge / Full RB

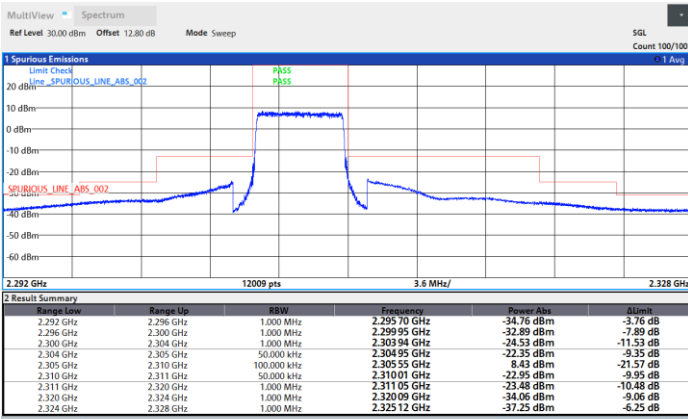

02:31:11 25.06.2021

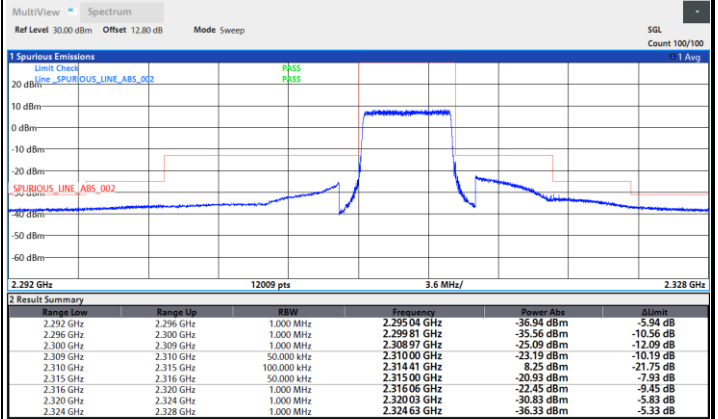

02:47:45 25.06.2021



FR1 n30 / 5MHz / DFT-S OFDM / 16QAM

Lowest Band Edge / 1RB0

Highest Band Edge / 1RBmax

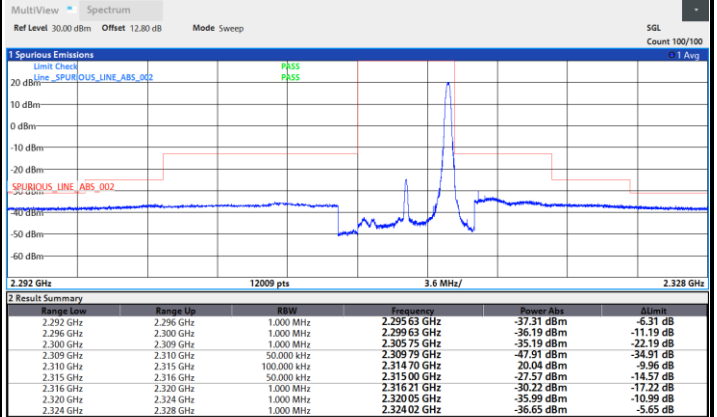
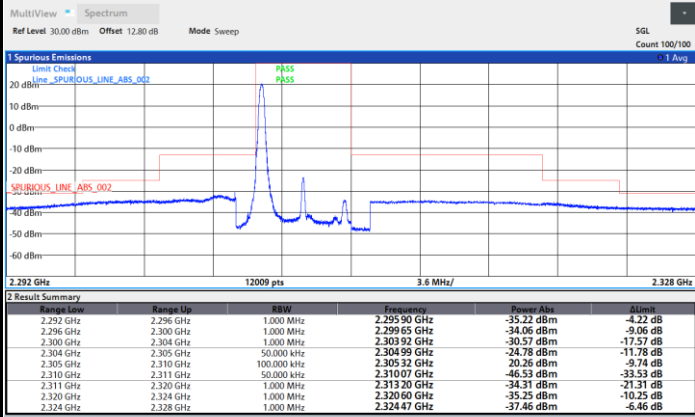

02:32:46 25.06.2021

02:49:38 25.06.2021

Lowest Band Edge / Full RB

Highest Band Edge / Full RB

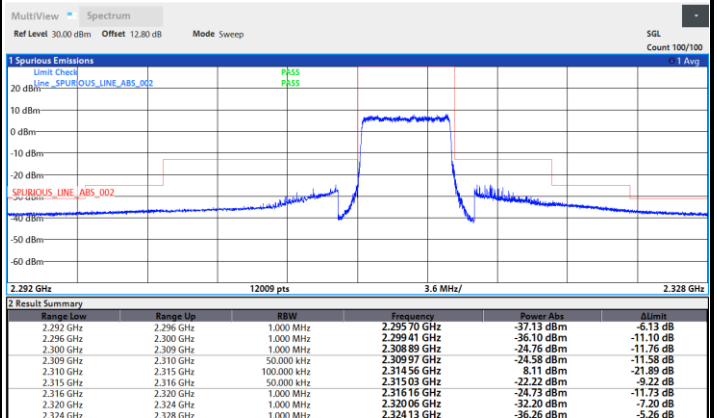
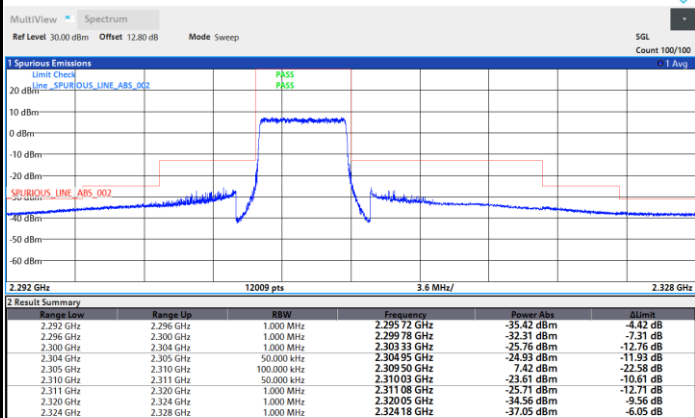

02:31:25 25.06.2021

02:48:23 25.06.2021



FR1 n30 / 5MHz / DFT-S OFDM / 64QAM

Lowest Band Edge / 1RB0

Highest Band Edge / 1RBmax

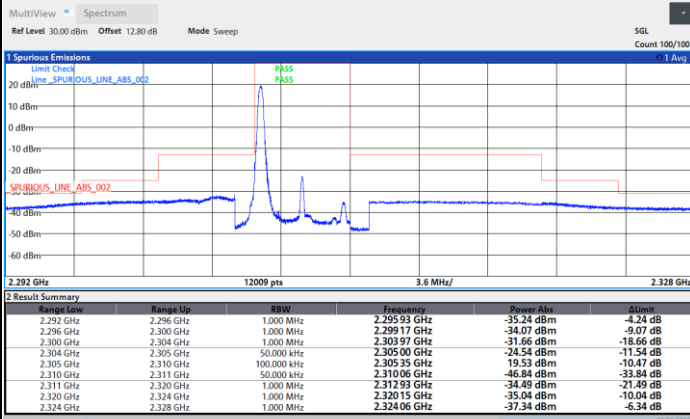

02:32:32 25.06.2021

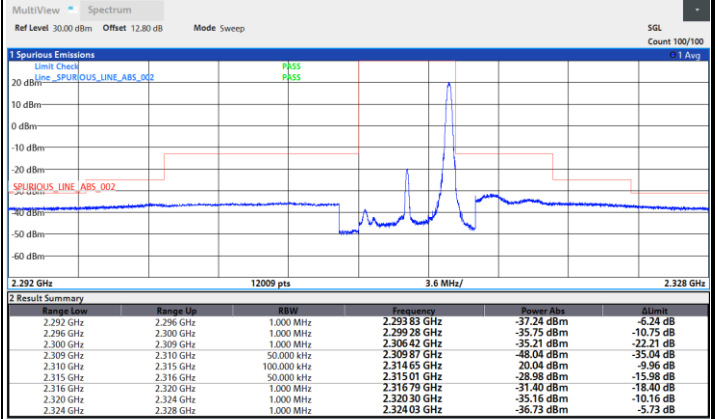

02:49:23 25.06.2021

Lowest Band Edge / Full RB

Highest Band Edge / Full RB

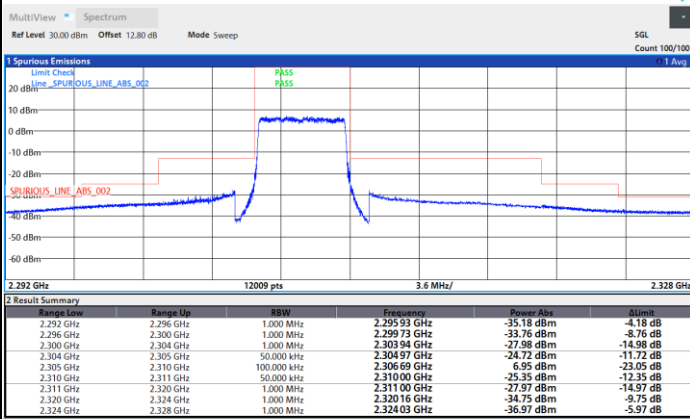

02:31:41 25.06.2021

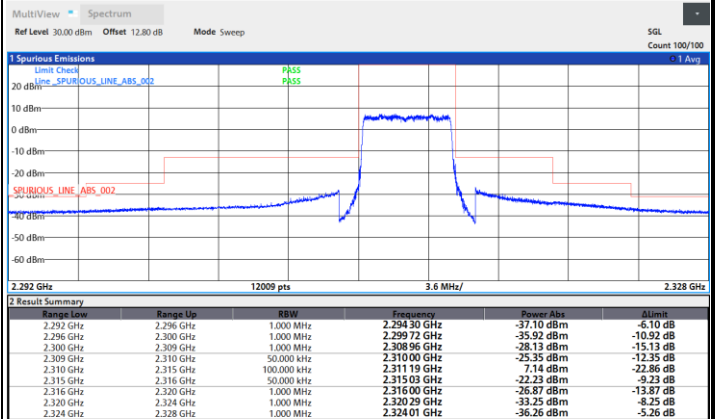

02:48:38 25.06.2021



FR1 n30 / 5MHz / DFT-S OFDM / 256QAM

Lowest Band Edge / 1RB0

Highest Band Edge / 1RBmax

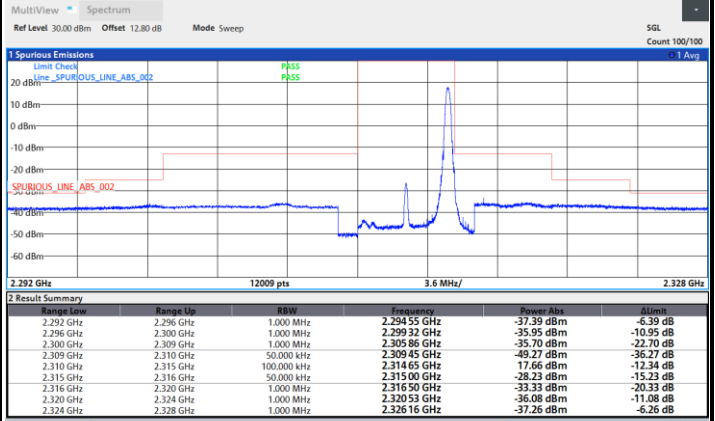
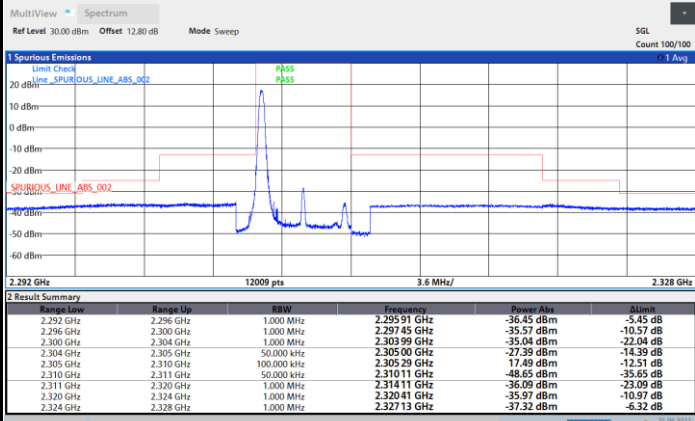

Lowest Band Edge / Full RB

Highest Band Edge / Full RB

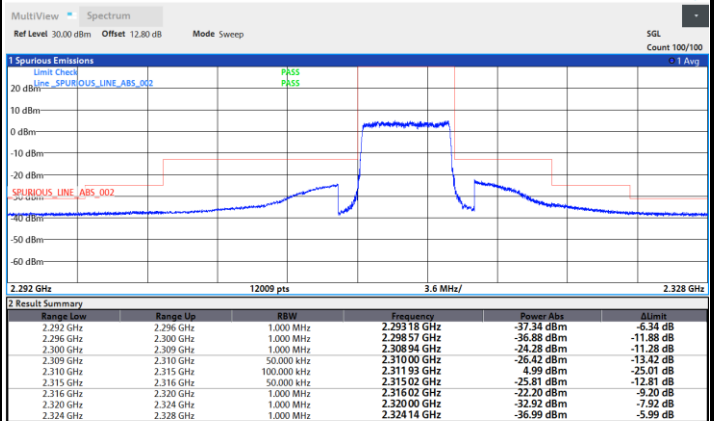
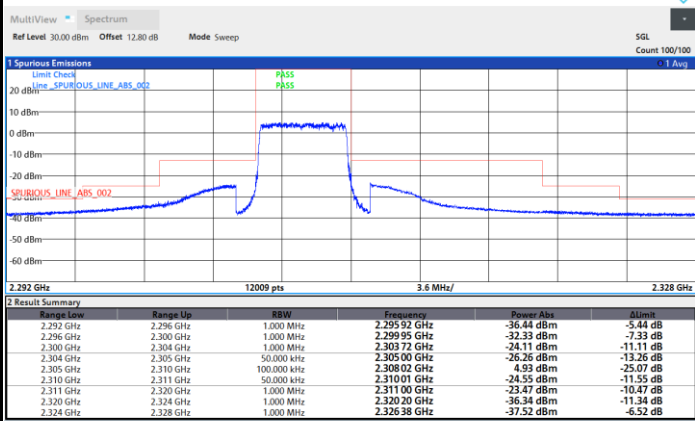

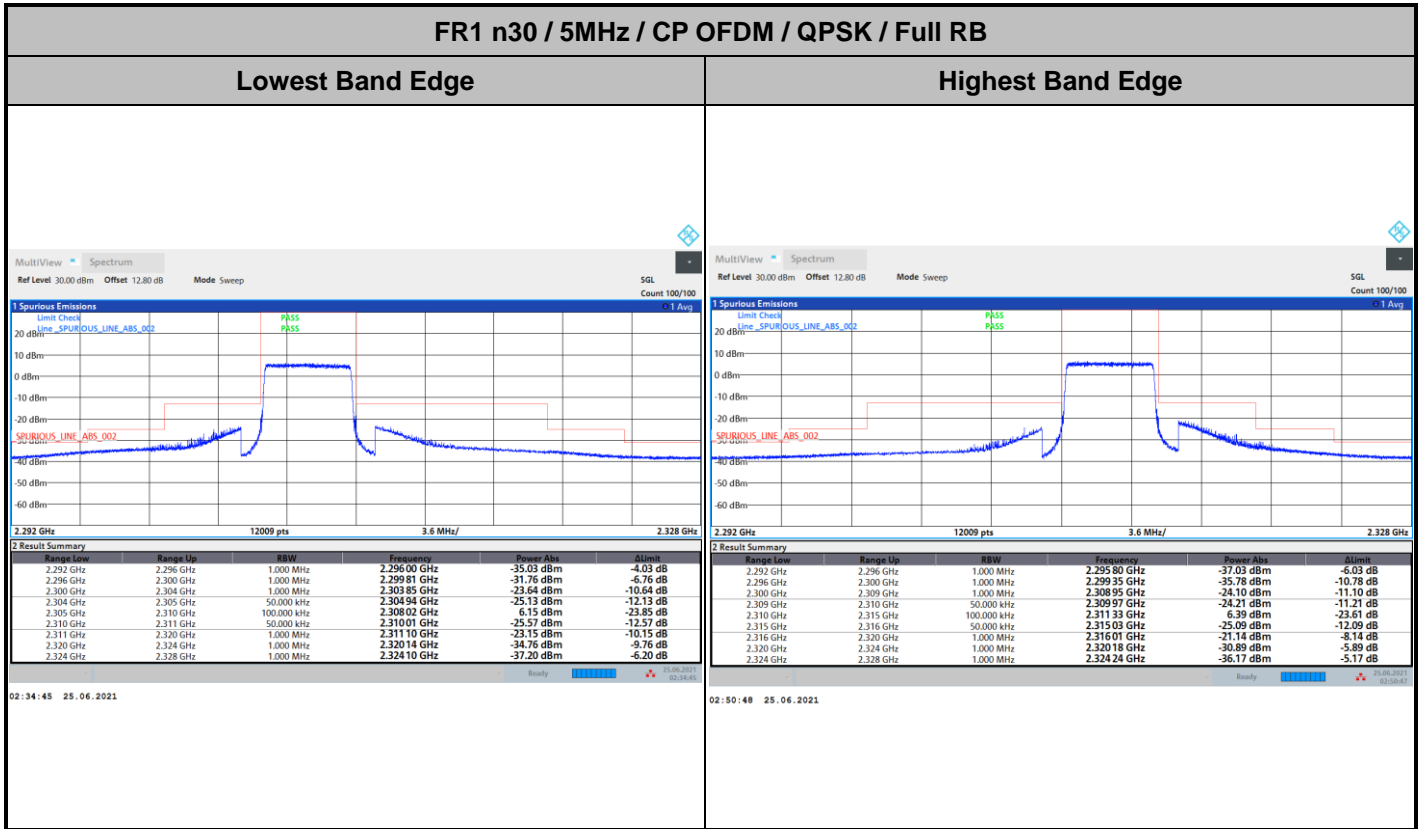



FR1 n30 / 10MHz / DFT-s-OFDM / PI/2 BPSK

Middle Band Edge / Full RB

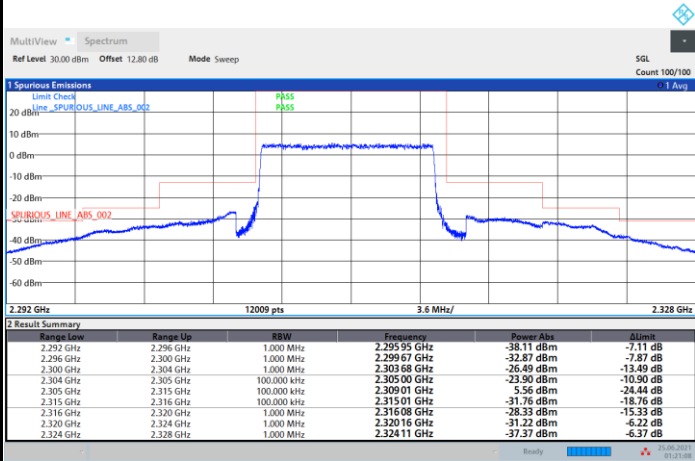

01:21:09 25.06.2021



FR1 n30 / 10MHz / DFT-s-OFDM / QPSK

Middle Band Edge / Full RB

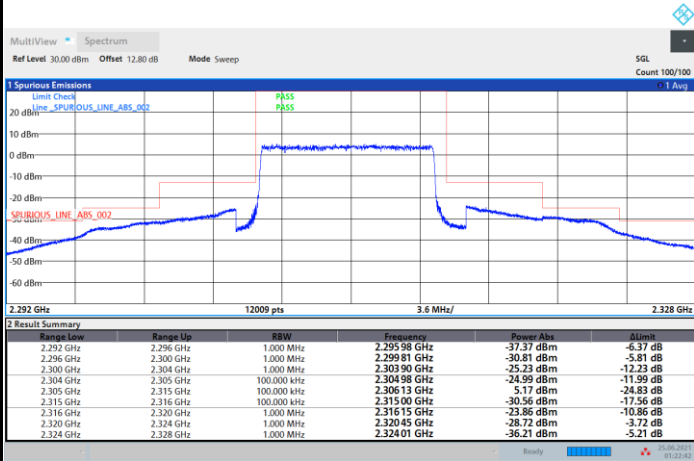



FR1 n30 / 10MHz / DFT-s-OFDM / 16QAM

Middle Band Edge / Full RB

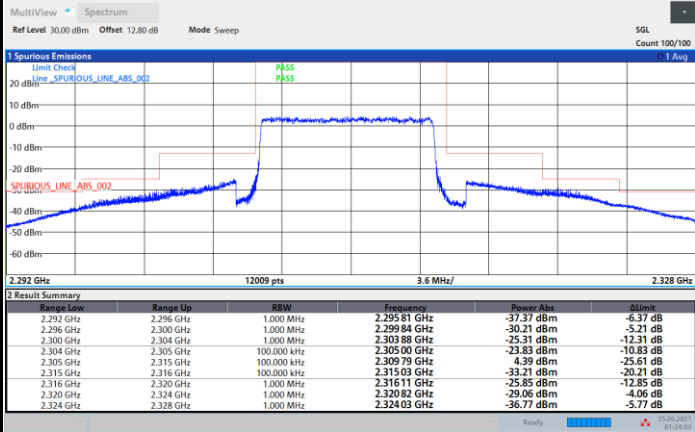

01:24:03 25.06.2021



FR1 n30 / 10MHz / DFT-s-OFDM / 64QAM

Middle Band Edge / Full RB

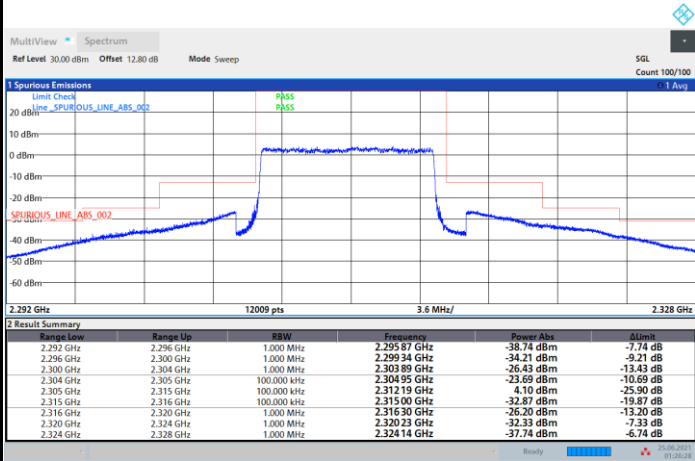

01:26:30 25.06.2021



FR1 n30 / 10MHz / DFT-s-OFDM / 256QAM

Middle Band Edge / Full RB

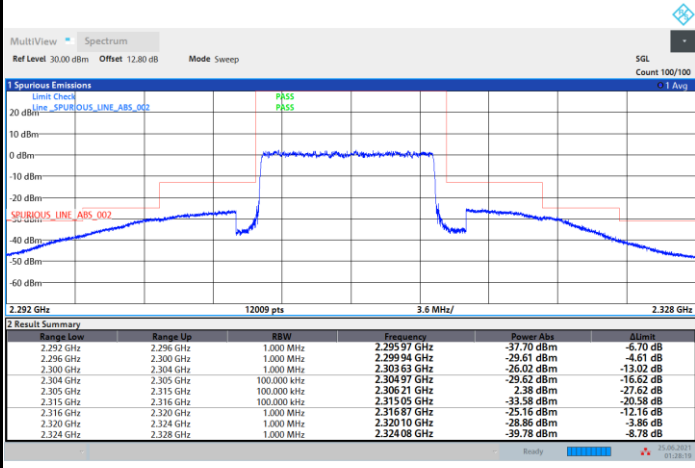



FR1 n30 / 10MHz / CP OFDM / QPSK / Full RB

Middle Band Edge / Full RB

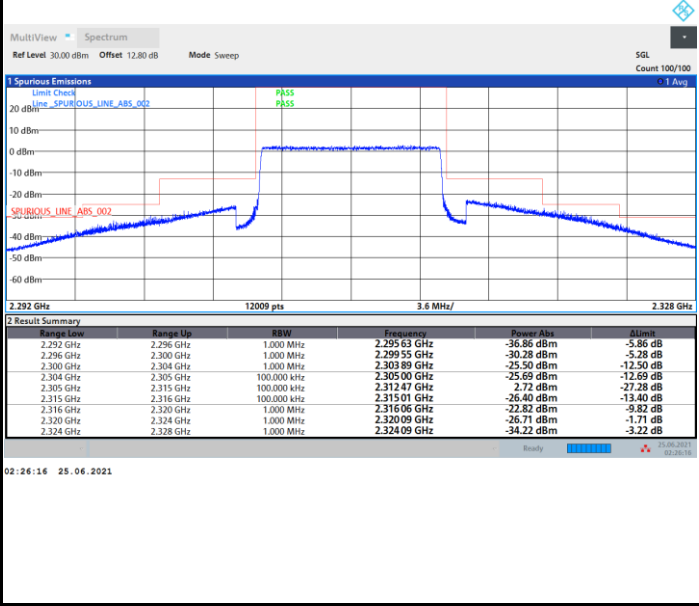



Conducted Spurious Emission

FR1 n30 / 5MHz / DFT-S OFDM / QPSK / 1RB1

Lowest Channel

Middle Channel

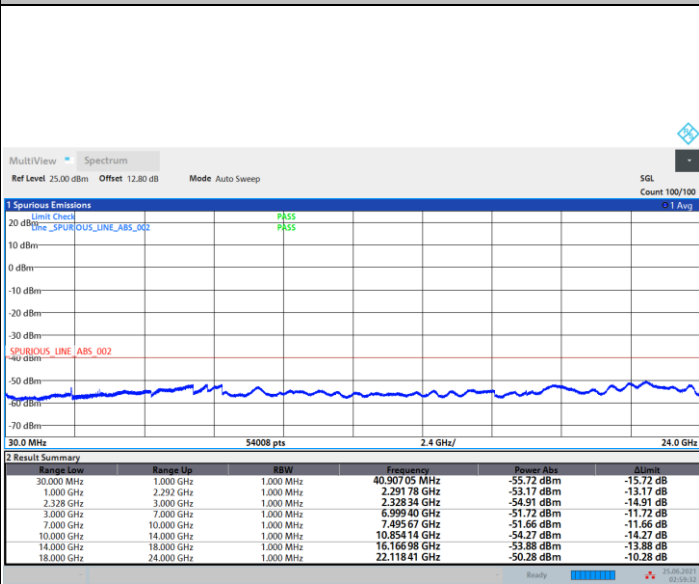
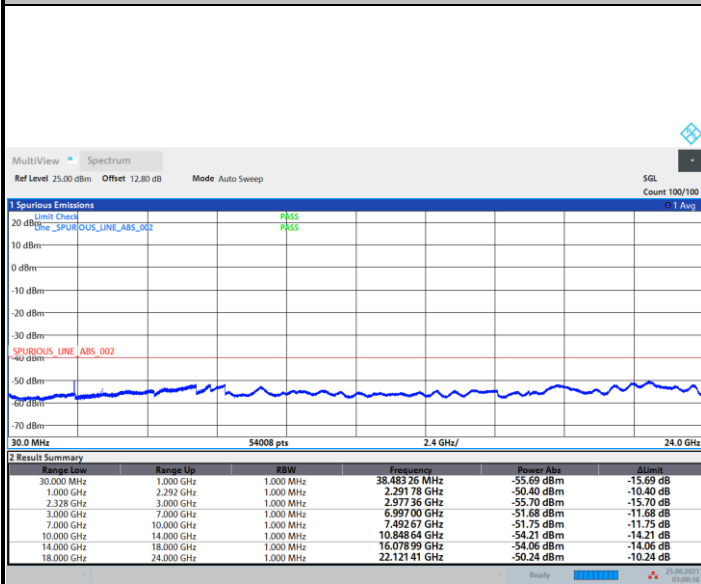

Highest Channel

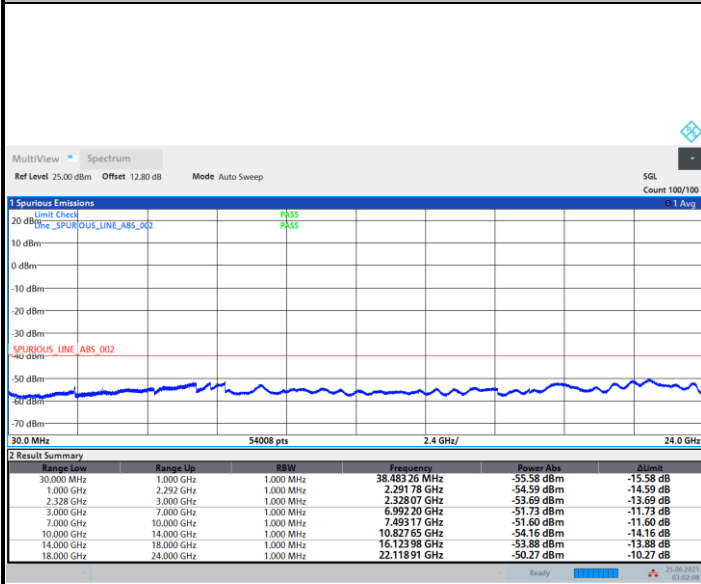



Frequency Stability

| Test Conditions | | FR1 n30 (PI/2 BPSK) / Middle Channel | Limit |
|------------------|-------------------|--------------------------------------|---------|
| Temperature (°C) | Voltage (Volt) | BW 10MHz | Note 2. |
| | | Deviation (ppm) | Result |
| 50 | Normal Voltage | 0.0016 | PASS |
| 40 | Normal Voltage | 0.0037 | |
| 30 | Normal Voltage | 0.0006 | |
| 20(Ref.) | Normal Voltage | 0.0000 | |
| 10 | Normal Voltage | 0.0023 | |
| 0 | Normal Voltage | 0.0015 | |
| -10 | Normal Voltage | 0.0005 | |
| -20 | Normal Voltage | 0.0035 | |
| -30 | Normal Voltage | 0.0035 | |
| 20 | Maximum Voltage | 0.0056 | |
| 20 | Normal Voltage | 0.0000 | |
| 20 | Battery End Point | 0.0041 | |

Note:

1. Normal Voltage =3.86 V. ; Battery End Point (BEP) =3.60 V. ; Maximum Voltage =4.45 V.
2. The frequency fundamental emissions stay within the authorized frequency block.



Appendix B. Test Results of Radiated Test

<Primary Antenna>

<Ant. 2>

EN-DC 12A-n30A

| EN-DC 12A-n30A / 5MHz / PI/2 BPSK | | | | | | | | | |
|-----------------------------------|-------------------|--------------|---------------|-------------------|-------------------|--------------------|----------------------|-----------------------|--------------------|
| Channel | Frequency (MHz) | EIRP (dBm) | Limit (dBm) | Over Limit (dB) | SPA Reading (dBm) | S.G. Power (dBm) | TX Cable loss (dB) | TX Antenna Gain (dBi) | Polarization (H/V) |
| Lowest | 4608 | -62.68 | -40 | -22.68 | -49.68 | -73.91 | 1.45 | 12.68 | H |
| | 6918 | -59.74 | -40 | -19.74 | -54.35 | -70.02 | 1.73 | 12.01 | H |
| | 9225 | -58.78 | -40 | -18.78 | -53.87 | -68.40 | 2.16 | 11.78 | H |
| | | | | | | | | | H |
| | | | | | | | | | H |
| | | | | | | | | | H |
| | 4608 | -63.62 | -40 | -23.62 | -49.83 | -74.85 | 1.45 | 12.68 | V |
| | 6916 | -59.85 | -40 | -19.85 | -54.01 | -70.14 | 1.73 | 12.02 | V |
| | 9225 | -58.27 | -40 | -18.27 | -54.36 | -67.89 | 2.16 | 11.78 | V |
| | | | | | | | | | V |
| | | | | | | | | | V |
| | | | | | | | | | V |
| Middle | 4614 | -62.83 | -40 | -22.83 | -49.86 | -74.05 | 1.46 | 12.68 | H |
| | 6924 | -59.94 | -40 | -19.94 | -54.59 | -70.22 | 1.73 | 12.01 | H |
| | 9234 | -59.15 | -40 | -19.15 | -54.24 | -68.76 | 2.16 | 11.77 | H |
| | | | | | | | | | H |
| | | | | | | | | | H |
| | | | | | | | | | H |
| | 4614 | -63.84 | -40 | -23.84 | -50.09 | -75.06 | 1.46 | 12.68 | V |
| | 6923 | -60.46 | -40 | -20.46 | -54.66 | -70.74 | 1.73 | 12.01 | V |
| | 9234 | -58.31 | -40 | -18.31 | -54.41 | -67.92 | 2.16 | 11.77 | V |
| | | | | | | | | | V |
| | | | | | | | | | V |
| | | | | | | | | | V |



| | | | | | | | | | |
|---------|------|--------|-----|--------|--------|--------|------|-------|---|
| Highest | 4620 | -63.00 | -40 | -23.00 | -50.05 | -74.22 | 1.46 | 12.68 | H |
| | 6930 | -59.63 | -40 | -19.63 | -54.32 | -69.90 | 1.73 | 12.00 | H |
| | 9243 | -58.89 | -40 | -18.89 | -53.97 | -68.48 | 2.16 | 11.76 | H |
| | | | | | | | | | H |
| | | | | | | | | | H |
| | | | | | | | | | H |
| | 4620 | -64.01 | -40 | -24.01 | -50.28 | -75.23 | 1.46 | 12.68 | V |
| | 6930 | -58.99 | -40 | -18.99 | -53.23 | -69.26 | 1.73 | 12.00 | V |
| | 9243 | -58.32 | -40 | -18.32 | -54.43 | -67.91 | 2.16 | 11.76 | V |
| | | | | | | | | | V |
| | | | | | | | | | V |
| | | | | | | | | | V |

Remark: Spurious emissions within 30-1000MHz were found more than 20dB below limit line.



| EN-DC 12A-n30A / 10MHz / PI/2 BPSK | | | | | | | | | |
|------------------------------------|-------------------|--------------|---------------|-------------------|-------------------|--------------------|----------------------|-----------------------|--------------------|
| Channel | Frequency (MHz) | EIRP (dBm) | Limit (dBm) | Over Limit (dB) | SPA Reading (dBm) | S.G. Power (dBm) | TX Cable loss (dB) | TX Antenna Gain (dBi) | Polarization (H/V) |
| Middle | 4614 | -63.19 | -40 | -23.19 | -50.2 | -74.41 | 1.46 | 12.68 | H |
| | 6918 | -59.26 | -40 | -19.26 | -53.87 | -69.54 | 1.73 | 12.01 | H |
| | 9225 | -59.13 | -40 | -19.13 | -54.23 | -68.75 | 2.16 | 11.78 | H |
| | | | | | | | | | H |
| | | | | | | | | | H |
| | | | | | | | | | H |
| | 4614 | -63.22 | -40 | -23.22 | -49.45 | -74.44 | 1.46 | 12.68 | V |
| | 6918 | -60.12 | -40 | -20.12 | -54.28 | -70.40 | 1.73 | 12.01 | V |
| | 9225 | -58.35 | -40 | -18.35 | -54.44 | -67.97 | 2.16 | 11.78 | V |
| | | | | | | | | | V |
| | | | | | | | | | V |
| | | | | | | | | | V |

Remark: Spurious emissions within 30-1000MHz were found more than 20dB below limit line.



<ASDIV Antenna>

<Ant. 0>

EN-DC 5A-n30A

| EN-DC 5A-n30A / 5MHz / PI/2 BPSK | | | | | | | | | |
|----------------------------------|-------------------|--------------|---------------|-------------------|-------------------|--------------------|----------------------|-----------------------|--------------------|
| Channel | Frequency (MHz) | EIRP (dBm) | Limit (dBm) | Over Limit (dB) | SPA Reading (dBm) | S.G. Power (dBm) | TX Cable loss (dB) | TX Antenna Gain (dBi) | Polarization (H/V) |
| Lowest | 4608 | -59.90 | -40 | -19.90 | -46.9 | -71.13 | 1.45 | 12.68 | H |
| | 6918 | -48.39 | -40 | -8.39 | -43 | -58.67 | 1.73 | 12.01 | H |
| | 9225 | -59.00 | -40 | -19.00 | -54.1 | -68.62 | 2.16 | 11.78 | H |
| | | | | | | | | | H |
| | | | | | | | | | H |
| | | | | | | | | | H |
| | 4608 | -60.59 | -40 | -20.59 | -46.81 | -71.82 | 1.45 | 12.68 | V |
| | 6916 | -51.62 | -40 | -11.62 | -45.78 | -61.91 | 1.73 | 12.02 | V |
| | 9225 | -57.99 | -40 | -17.99 | -54.08 | -67.61 | 2.16 | 11.78 | V |
| | | | | | | | | | V |
| | | | | | | | | | V |
| Middle | 4614 | -60.46 | -40 | -20.46 | -47.49 | -71.68 | 1.46 | 12.68 | H |
| | 6924 | -49.63 | -40 | -9.63 | -44.28 | -59.91 | 1.73 | 12.01 | H |
| | 9234 | -59.06 | -40 | -19.06 | -54.15 | -68.67 | 2.16 | 11.77 | H |
| | | | | | | | | | H |
| | | | | | | | | | H |
| | | | | | | | | | H |
| | 4614 | -60.78 | -40 | -20.78 | -47.03 | -72.00 | 1.46 | 12.68 | V |
| | 6923 | -51.02 | -40 | -11.02 | -45.22 | -61.30 | 1.73 | 12.01 | V |
| | 9234 | -58.03 | -40 | -18.03 | -54.13 | -67.64 | 2.16 | 11.77 | V |
| | | | | | | | | | V |
| | | | | | | | | | V |



| | | | | | | | | | |
|---------|------|--------|-----|--------|--------|--------|------|-------|---|
| Highest | 4620 | -60.05 | -40 | -20.05 | -47.1 | -71.27 | 1.46 | 12.68 | H |
| | 6930 | -50.23 | -40 | -10.23 | -44.92 | -60.50 | 1.73 | 12.00 | H |
| | 9243 | -58.73 | -40 | -18.73 | -53.81 | -68.32 | 2.16 | 11.76 | H |
| | | | | | | | | | H |
| | | | | | | | | | H |
| | | | | | | | | | H |
| | 4620 | -60.80 | -40 | -20.80 | -47.07 | -72.02 | 1.46 | 12.68 | V |
| | 6930 | -51.10 | -40 | -11.10 | -45.34 | -61.37 | 1.73 | 12.00 | V |
| | 9243 | -57.70 | -40 | -17.70 | -53.81 | -67.29 | 2.16 | 11.76 | V |
| | | | | | | | | | V |
| | | | | | | | | | V |
| | | | | | | | | | V |

Remark: Spurious emissions within 30-1000MHz were found more than 20dB below limit line.



| EN-DC 5A-n30A / 10MHz / PI/2 BPSK | | | | | | | | | |
|-----------------------------------|-------------------|--------------|---------------|-------------------|-------------------|--------------------|----------------------|-----------------------|--------------------|
| Channel | Frequency (MHz) | EIRP (dBm) | Limit (dBm) | Over Limit (dB) | SPA Reading (dBm) | S.G. Power (dBm) | TX Cable loss (dB) | TX Antenna Gain (dBi) | Polarization (H/V) |
| Middle | 4614 | -62.75 | -40 | -22.75 | -49.76 | -73.97 | 1.46 | 12.68 | H |
| | 6918 | -50.44 | -40 | -10.44 | -45.05 | -60.72 | 1.73 | 12.01 | H |
| | 9225 | -59.22 | -40 | -19.22 | -54.32 | -68.84 | 2.16 | 11.78 | H |
| | | | | | | | | | H |
| | | | | | | | | | H |
| | | | | | | | | | H |
| | 4614 | -63.77 | -40 | -23.77 | -50 | -74.99 | 1.46 | 12.68 | V |
| | 6918 | -53.52 | -40 | -13.52 | -47.68 | -63.80 | 1.73 | 12.01 | V |
| | 9225 | -57.98 | -40 | -17.98 | -54.07 | -67.60 | 2.16 | 11.78 | V |
| | | | | | | | | | V |
| | | | | | | | | | V |
| | | | | | | | | | V |

Remark: Spurious emissions within 30-1000MHz were found more than 20dB below limit line.

————THE END————