



HEARING AID COMPATIBILITY RF EMISSIONS TEST REPORT

FCC ID : A4RG9FPL
Equipment : Phone
Model Name : G9FPL, G0B96
M-Rating : M3
Applicant : Google LLC
1600 Amphitheatre Parkway,
Mountain View, California, 94043 USA
Standard : FCC 47 CFR §20.19
ANSI C63.19-2011

The product was received on Nov. 23, 2022 and testing was started from Jan. 04, 2023 and completed on Mar. 31, 2023. We, SPORTON INTERNATIONAL INC., would like to declare that the tested sample provide by manufacturer and the test data has been evaluated in accordance with the test procedures given in ANSI 63.19-2011 / 47 CFR Part 20.19 and has been pass the FCC requirement.

The test results in this report apply exclusively to the tested model / sample. Without written approval of SPORTON INTERNATIONAL INC. Laboratory, the test report shall not be reproduced except in full.

Approved by: Cona Huang / Deputy Manager

SPORTON INTERNATIONAL INC. EMC & Wireless Communications Laboratory
No. 52, Huaya 1st Rd., Guishan Dist., Taoyuan City, Taiwan (R.O.C.)



Table of Contents

1. General Information..... 4

2. Testing Location..... 5

3. Applied Standards 5

4. RF Audio Interference Level..... 5

5. Air Interface and Operating Mode..... 6

6. Measurement System Specification 7

 6.1 E-Field Probe System..... 7

 6.2 Data Storage and Evaluation..... 8

7. RF Emissions Test Procedure..... 9

8. Test Equipment List 12

9. Measurement System Validation 13

10. Modulation Interference Factor..... 14

11. Low-power Exemption..... 15

12. Conducted RF Output Power (Unit: dBm)..... 27

13. HAC RF Emission Test Results..... 35

14. Uncertainty Assessment 39

15. References..... 40

Appendix A. Plots of System Performance Check

Appendix B. Plots of RF Emission Measurement

Appendix C. DASYS Calibration Certificate

Appendix D. Test Setup Photos

Appendix E. UID specifications for HAC RFE



History of this test report

Report No.	Version	Description	Issued Date
HA262403-04A	Rev. 01	Initial issue of report	Mar. 31, 2023



1. General Information

Product Feature & Specification	
Applicant Name	Google LLC
Equipment Name	Phone
Model Name	G9FPL, G0B96
FCC ID	A4RG9FPL
S/N	2B021FDHS0002H 2B021FDHS0001R 2B021FDHS00025
Frequency Band	GSM850: 824.2 MHz ~ 848.8 MHz GSM1900: 1850.2 MHz ~ 1909.8 MHz WCDMA Band II: 1850 MHz ~ 1910 MHz WCDMA Band IV: 1710 MHz ~ 1755 MHz WCDMA Band V: 824 MHz ~ 849 MHz LTE Band 2: 1850 MHz ~ 1910 MHz LTE Band 4: 1710 MHz ~ 1755 MHz LTE Band 5: 824 MHz ~ 849 MHz LTE Band 7: 2500 MHz ~ 2570 MHz LTE Band 12: 699 MHz ~ 716 MHz LTE Band 13: 777 MHz ~ 787 MHz LTE Band 14: 788 MHz ~ 798 MHz LTE Band 17: 704 MHz ~ 716 MHz LTE Band 25: 1850 MHz ~ 1915 MHz LTE Band 26: 814 MHz ~ 849 MHz LTE Band 30: 2305 MHz ~ 2315 MHz LTE Band 38: 2570 MHz ~ 2620 MHz LTE Band 41: 2496 MHz ~ 2690 MHz LTE Band 48: 3550 MHz ~ 3700 MHz LTE Band 66: 1710 MHz ~ 1780 MHz LTE Band 71: 663 MHz ~ 698 MHz 5G NR n2 : 1850 MHz ~ 1910 MHz 5G NR n5 : 824 MHz ~ 849 MHz 5G NR n7 : 2500 MHz ~ 2570 MHz 5G NR n12 : 699 MHz ~ 716 MHz 5G NR n14 : 788 MHz ~ 798 MHz 5G NR n25 : 1850 MHz ~ 1915 MHz 5G NR n30 : 2305 MHz ~ 2315 MHz 5G NR n38 : 2570 MHz ~ 2620 MHz 5G NR n41 : 2496 MHz ~ 2690 MHz 5G NR n48 : 3550 MHz ~ 3700 MHz 5G NR n66 : 1710 MHz ~ 1780 MHz 5G NR n71 : 663 MHz ~ 698 MHz 5G NR n77: 3450 MHz ~ 3550 MHz, 3700 MHz ~ 3980 MHz 5G NR n258 : 24.25 GHz~24.45 GHz, 24.75GHz ~25.25GHz 5G NR n260 : 37 GHz~40 GHz 5G NR n261 : 27.5 GHz~28.35 GHz WLAN 2.4GHz Band: 2400 MHz ~ 2483.5 MHz WLAN 5.2G Band: 5150 MHz ~ 5250 MHz WLAN 5.3G Band: 5250 MHz ~ 5350 MHz WLAN 5.5G Band: 5470 MHz ~ 5725 MHz WLAN 5.8G Band: 5725 MHz ~ 5850 MHz WLAN 5.9G Band: 5850 MHz ~ 5895 MHz WLAN 6E: 5925 MHz ~ 6425 MHz, 6425 MHz ~ 6525 MHz, 6525 MHz ~ 6875 MHz, 6875 MHz ~ 7125 MHz Bluetooth: 2400 MHz ~ 2483.5 MHz NFC: 13.56 MHz WPT Client: 110 kHz ~ 148.5 kHz UWB: 6489.6 MHz, 7987.2 MHz
Mode	GSM/GPRS/EGPRS RMC/AMR 12.2Kbps HSDPA HSUPA LTE: QPSK, 16QAM, 64QAM, 256QAM 5G NR: DFT-s-OFDM/CP-OFDM, Pi/2 BPSK/QPSK/16QAM/64QAM/256QAM WLAN: 802.11a/b/g/n/ac/ax HT20/HT40/VHT20/VHT40/VHT80/VHT160/HE20/HE40/HE80/HE160 Bluetooth BR/EDR/LE NFC: ASK WPT Client: ASK UWB: BPM-BPSK

Reviewed by: Jason Wang
Report Producer: Carlie Tsai



2. Testing Location

Sporton Lab is accredited to ISO 17025 by Taiwan Accreditation Foundation (TAF code: 1190) and the FCC designation No. TW1190 under the FCC 2.948(e) by Mutual Recognition Agreement (MRA) in FCC test.

Testing Laboratory	
Test Site	SPORTON INTERNATIONAL INC.
Test Site Location	No. 52, Huaya 1st Rd., Guishan Dist., Taoyuan City, Taiwan (R.O.C.) TEL: +886-3-327-3456 FAX: +886-3-328-4978
Test Site No.	Sporton Site No.: SAR04-HY

3. Applied Standards

- FCC CFR47 Part 20.19
- ANSI C63.19-2011
- FCC KDB 285076 D01 HAC Guidance v06r02
- FCC KDB 285076 D03 HAC FAQ v01r06

4. RF Audio Interference Level

FCC wireless hearing aid compatibility rules ensure that consumers with hearing loss are able to access wireless communications services through a wide selection of handsets without experiencing disabling radio frequency (RF) interference or other technical obstacles.

To define and measure the hearing aid compatibility of handsets, in CFR47 part 20.19 ANSI C63.19 is referenced. A handset is considered hearing aid-compatible for acoustic coupling if it meets a rating of at least M3 under ANSI C63.19, and A handset is considered hearing aid compatible for inductive coupling if it meets a rating of at least T3.

According to ANSI C63.19 2011 version, for acoustic coupling, the RF electric field emissions of wireless communication devices should be measured and rated according to the emission level as below.

Emission Categories	E-field emissions	
	<960Mhz	>960Mhz
M1	50 to 55 dB (V/m)	40 to 45 dB (V/m)
M2	45 to 50 dB (V/m)	35 to 40 dB (V/m)
M3	40 to 45 dB (V/m)	30 to 35 dB (V/m)
M4	<40 dB (V/m)	<30 dB (V/m)

Table 5.1 Telephone near-field categories in linear units



5. Air Interface and Operating Mode

Air Interface	Band MHz	Type	C63.19 Tested	Simultaneous Transmitter	Name of Voice Service	Power Reduction
GSM	GSM850	VO	Yes	WLAN, BT	CMRS Voice	No
	GSM1900			WLAN, BT		No
	EDGE850	VD	Yes	WLAN, BT	Google Meet	No
	EDGE1900			WLAN, BT		
WCDMA	Band II	VO	No ⁽¹⁾	WLAN, BT	CMRS Voice	No
	Band IV			WLAN, BT		No
	Band V	VD	No ⁽¹⁾	WLAN, BT	Google Meet	No
	HSPA			WLAN, BT		No
LTE (FDD)	Band 2	VD	No ⁽¹⁾	5G NR, WLAN, BT	VoLTE / Google Meet	No
	Band 4			5G NR, WLAN, BT		No
	Band 5			5G NR, WLAN, BT		No
	Band 7			5G NR, WLAN, BT		No
	Band 12			5G NR, WLAN, BT		No
	Band 13			5G NR, WLAN, BT		No
	Band 14			5G NR, WLAN, BT		No
	Band 17			5G NR, WLAN, BT		No
	Band 25			5G NR, WLAN, BT		No
	Band 26			5G NR, WLAN, BT		No
	Band 30			5G NR, WLAN, BT		No
	Band 66			5G NR, WLAN, BT		No
	Band 71			5G NR, WLAN, BT		No
LTE (TDD)	Band 38	VD	Yes	5G NR, WLAN, BT	VoLTE / Google Meet	No
	Band 41			5G NR, WLAN, BT		No
	Band 48			5G NR, WLAN, BT		No
5G NR	n2	VD	No ⁽¹⁾	LTE, WLAN, BT	VoNR / Google Meet	No
	n5			LTE, WLAN, BT		No
	n7			LTE, WLAN, BT		No
	n12			LTE, WLAN, BT		No
	n14			LTE, WLAN, BT		No
	n25			LTE, WLAN, BT		No
	n30			LTE, WLAN, BT		No
	n38			LTE, WLAN, BT		No
	n66			LTE, WLAN, BT		No
	n71			LTE, WLAN, BT		No
	n41	VD	Yes	LTE, WLAN, BT	Google Meet	No
	n48			LTE, WLAN, BT		No
	n77			LTE, WLAN, BT		No
	n258			LTE, WLAN, BT		No
Wi-Fi	2450	VD	Yes	GSM, WCDMA, LTE, 5G NR, 5G/6G WLAN	VoWiFi / Google Meet	No
	5200			GSM, WCDMA, LTE, 5G NR, 2.4G WLAN, BT		No
	5300			GSM, WCDMA, LTE, 5G NR, 2.4G WLAN, BT		No
	5500			GSM, WCDMA, LTE, 5G NR, 2.4G WLAN, BT		No
	5800 / 5900			GSM, WCDMA, LTE, 5G NR, 2.4G WLAN, BT		No
Wi-Fi	U-NII 5	VD	Yes ⁽³⁾	GSM, WCDMA, LTE, 5G NR, 2.4G WLAN, BT	VoWiFi / Google Meet	No
	U-NII 6		No ⁽²⁾	GSM, WCDMA, LTE, 5G NR, 2.4G WLAN, BT		No
	U-NII 7			GSM, WCDMA, LTE, 5G NR, 2.4G WLAN, BT		No
	U-NII 8			GSM, WCDMA, LTE, 5G NR, 2.4G WLAN, BT		No
BT	2450	DT	No	GSM, WCDMA, LTE, 5G NR, 5G/6G WLAN	NA	No

Type Transport:
 VO= Voice only
 DT= Digital Transport only (no voice)
 VD= CMRS and IP Voice Service over Digital Transport

- Remark:**
- The air interface is exempted from testing by low power exemption that its average antenna input power plus its MIF is ≤ 17 dBm, and is rated as M4.
 - The FR2n258/260/261 and U-NII 6/7/8 were above 6GHz and were not evaluated due to outside of the current scope of ANSI C63.19 and FCC HAC regulations.
 - The UNII-5 was evaluated for operations which are entirely below 6 GHz, above 6 GHz were not evaluated due outside of the current scope of ANSI C63.19 and FCC HAC regulations
 - Because features of Google Meet allow the option of voice-only communications, Meet has been tested for HAC/T-Coil compatibility to ensure the best user experience.

6. Measurement System Specification

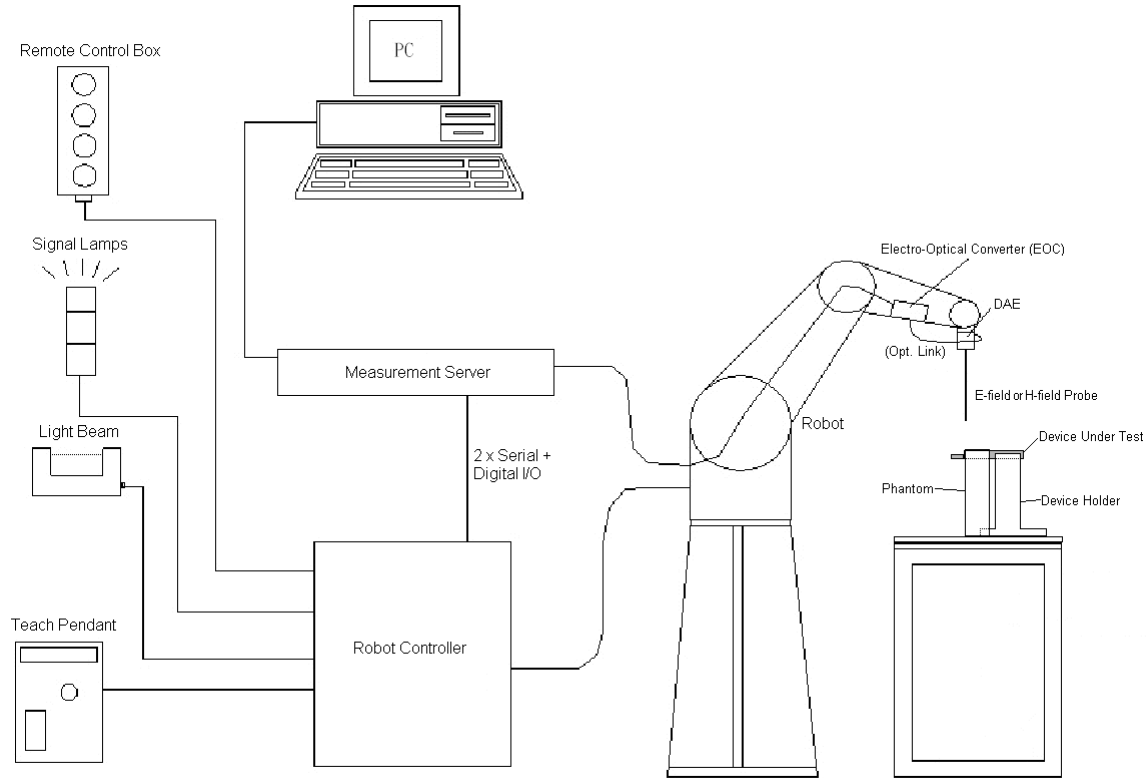

Fig 5.1 System Configurations

6.1 E-Field Probe System

E-Field Probe Specification

<ER3DV6>

Construction	One dipole parallel, two dipoles normal to probe axis Built-in shielding against static charges
Calibration	In air from 100 MHz to 3.0 GHz (absolute accuracy $\pm 6.0\%$, $k=2$)
Frequency	100 MHz to 6 GHz; Linearity: ± 2.0 dB (100 MHz to 3 GHz)
Directivity	± 0.2 dB in air (rotation around probe axis) ± 0.4 dB in air (rotation normal to probe axis)
Dynamic Range	2 V/m to 1000 V/m (M3 or better device readings fall well below diode compression point)
Linearity	± 0.2 dB
Dimensions	Overall length: 330 mm (Tip: 16 mm) Tip diameter: 8 mm (Body: 12 mm) Distance from probe tip to dipole centers: 2.5 mm



Fig 5.2 Photo of E-field Probe

Probe Tip Description:

HAC field measurements take place in the close near field with high gradients. Increasing the measuring distance from the source will generally decrease the measured field values (in case of the validation dipole approx. 10% per mm).

6.2 Data Storage and Evaluation

The DASY software stores the assessed data from the data acquisition electronics as raw data (in microvolt readings from the probe sensors), together with all the necessary software parameters for the data evaluation (probe calibration data, and device frequency and modulation data) in measurement files.

Probe parameters :	- Sensitivity	Norm _i , a _{i0} , a _{i1} , a _{i2}
	- Conversion factor	ConvF _i
	- Diode compression point	dcp _i
Device parameters :	- Frequency	f
	- Crest factor	cf
Media parameters :	- Conductivity	σ
	- Density	ρ

The formula for each channel can be given as :

$$V_i = U_i + U_i^2 \cdot \frac{cf}{dcp_i}$$

with V_i = compensated signal of channel i , ($i = x, y, z$)
 U_i = input signal of channel i , ($i = x, y, z$)
 cf = crest factor of exciting field (DASY parameter)
 dcp_i = diode compression point (DASY parameter)

From the compensated input signals, the primary field data for each channel can be evaluated :

$$\text{E-field Probes : } E_i = \sqrt{\frac{V_i}{\text{Norm}_i \cdot \text{ConvF}}}$$

with V_i = compensated signal of channel i , ($i = x, y, z$)
 Norm_i = sensor sensitivity of channel i , ($i = x, y, z$), $\mu\text{V}/(\text{V/m})^2$ for E-field Probes
 ConvF = sensitivity enhancement in solution
 f = carrier frequency [GHz]
 E_i = electric field strength of channel i in V/m

The RSS value of the field components gives the total field strength (Hermitian magnitude) :

$$E_{\text{tot}} = \sqrt{E_x^2 + E_y^2 + E_z^2}$$

The primary field data are used to calculate the derived field units.



7. RF Emissions Test Procedure

Referenced from ANSI C63.19 -2011 section 5.5.1

- a. Confirm the proper operation of the field probe, probe measurement system, and other instrumentation and the positioning system.
- b. Position the WD in its intended test position.
- c. Set the WD to transmit a fixed and repeatable combination of signal power and modulation characteristic that is representative of the worst case (highest interference potential) encountered in normal use. Transiently occurring start-up, changeover, or termination conditions, or other operations likely to occur less than 1% of the time during normal operation, may be excluded from consideration.
- d. The center sub-grid shall be centered on the T-Coil mode perpendicular measurement point or the acoustic output, as appropriate. Locate the field probe at the initial test position in the 50 mm by 50 mm grid, which is contained in the measurement plane, refer to illustrated in Figure 8.2. If the field alignment method is used, align the probe for maximum field reception.
- e. Record the reading at the output of the measurement system.
- f. Scan the entire 50 mm by 50 mm region in equality spaced increments and record the reading at each measurement point, The distance between measurement points shall be sufficient to assure the identification of the maximum reading.
- g. Identify the five contiguous sub-grids around the center sub-grid whose maximum reading is the lowest of all available choices. This eliminates the three sub-grids with the maximum readings. Thus, the six areas to be used to determine the WD's highest emissions are identified.
- h. Identify the maximum reading within the non-excluded sub-grids identified in step g).
- i. Indirect measurement method
- j. The RF audio interference level in dB (V/m) is obtained by adding the MIF (in dB) to the maximum steady-state rms field-strength reading, in dB (V/m)
- k. Compare this RF audio interference level with the categories in ANSI C63.19-2011 clause 8 and record the resulting WD category rating.
- l. For the T-Coil perpendicular measurement location is ≥ 5.0 mm from the center of the acoustic output, then two different 50 mm by 50 mm areas may need to be scanned, the first for the microphone mode assessment and the second for the T-Coil assessment.
- m. The second for the T-Coil assessment, with the grid shifted so that it is centered on the perpendicular measurement point. Record the WD category rating.

Test Instructions

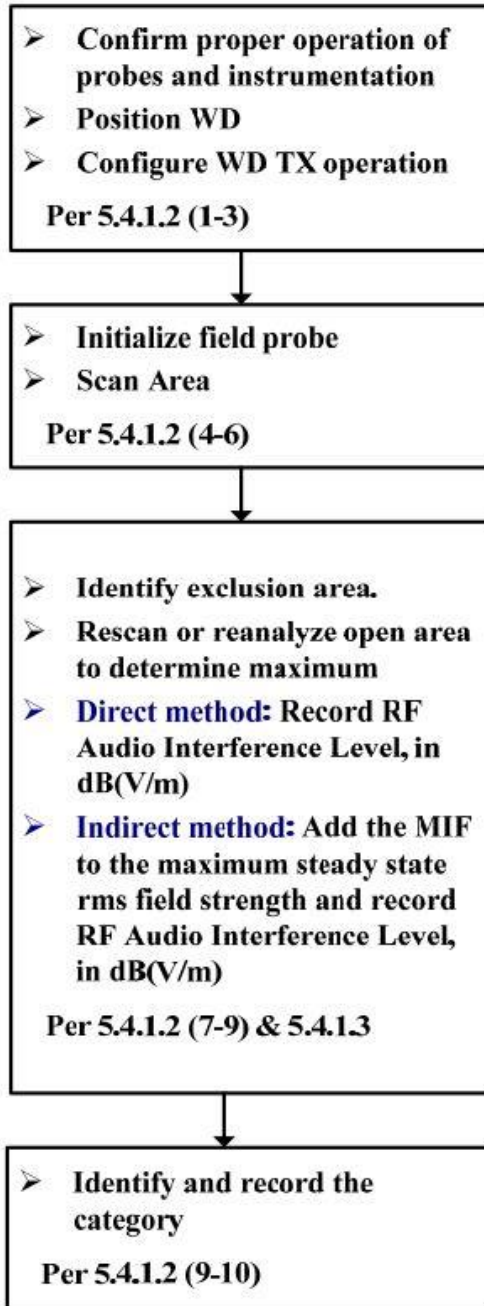

Figure 8.1 RF Emissions Flow Chart

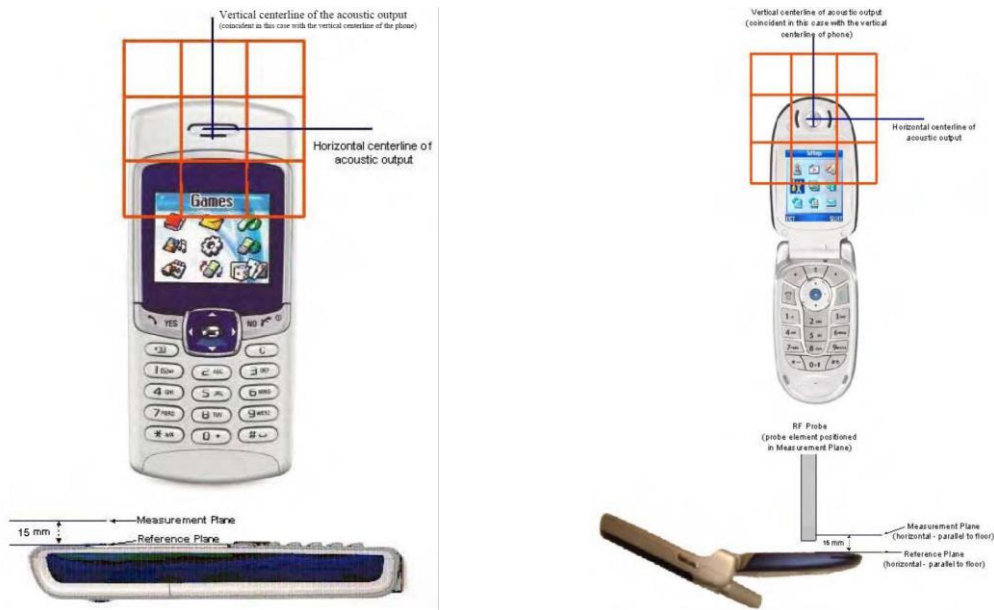

Fig 8.2 EUT reference and plane for HAC RF emission measurements

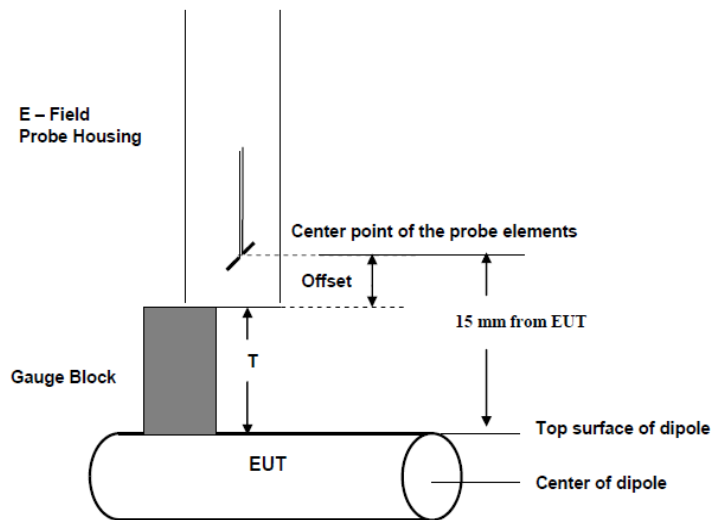

Fig. 8.3 Gauge block with E-field probe



8. Test Equipment List

Table with 6 columns: Manufacturer, Name of Equipment, Type/Model, Serial Number, Last Cal., Due Date. Lists various test equipment including calibration dipoles, signal generators, power meters, and spectrum analyzers.

Note:

- 1. NCR: "No-Calibration Required"
2. The dipole calibration interval can be extended to 3 years with justification according to KDB 865664 D01. The dipoles are also not physically damaged, or repaired during the interval.

9. Measurement System Validation

Each DASY system is equipped with one or more system validation kits. These units, together with the predefined measurement procedures within the DASY software, enable the user to conduct the system performance check and system validation. System validation kit includes a dipole, tripod holder to fix it underneath the test Arch and a corresponding distance holder.

The system performance check verifies that the system operates within its specifications. System and operator errors can be detected and corrected. It is recommended that the system performance check be performed prior to any usage of the system in order to guarantee reproducible results. The system performance check uses normal HAC measurements in a simplified setup with a well characterized source. This setup was selected to give a high sensitivity to all parameters that might fail or vary over time. The system check does not intend to replace the calibration of the components, but indicates situations where the system uncertainty is exceeded due to drift or failure.

<Test Setup>

1. In the simplified setup for system evaluation, the EUT is replaced by a calibrated dipole and the power source is replaced by a continuous wave which comes from a signal generator.
2. The center point of the probe element(s) is 15mm from the closest surface of the dipole elements.
3. The calibrated dipole must be placed beneath the arch phantom. The equipment setup is shown below:
4. The output power on dipole port must be calibrated to 20dBm (100mW) before dipole is connected.

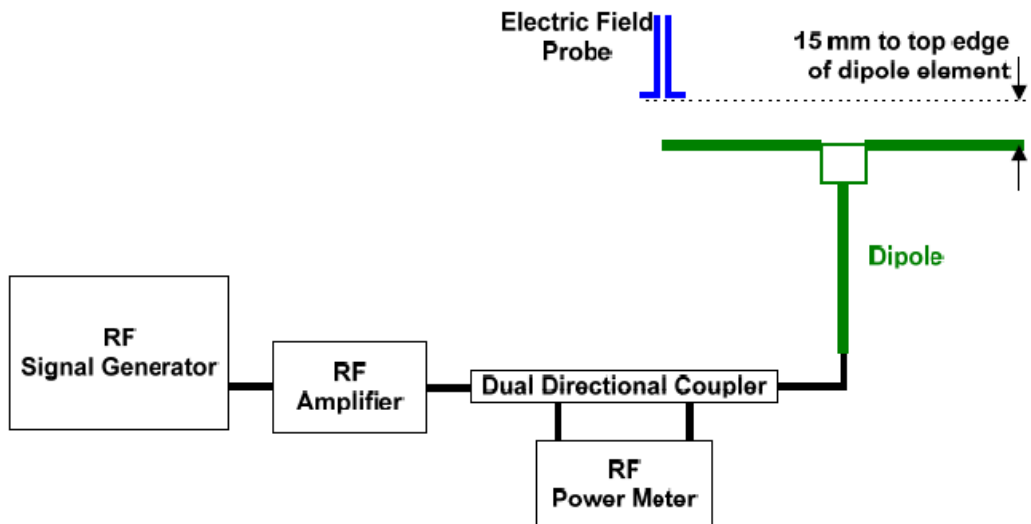

Fig. 7.1 Setup Diagram

<Validation Results>

Comparing to the original E-field value provided by SPEAG, the verification data should be within its specification of 25 %. Table 6.1 shows the target value and measured value. The table below indicates the system performance check can meet the variation criterion and the plots can be referred to appendix A of this report.

$$\text{Deviation} = ((\text{Average E-field Value}) - (\text{Target value})) / (\text{Target value}) * 100\%$$

Frequency (MHz)	Input Power (dBm)	Target Value (V/m)	E-Field 1 (V/m)	E-Field 2 (V/m)	Average Value (V/m)	Deviation (%)	Date
835	20	106.8	104.6	101.8	103.2	-3.37	Jan. 15, 2023
1880	20	85.5	86.4	83.92	85.16	-0.40	Jan. 15, 2023
2450	20	85.5	86.49	85.43	85.96	0.54	Jan. 05, 2023
2600	20	82.9	87.72	88.59	88.155	6.34	Jan. 04, 2023
3500	20	83.4	87.89	86.76	87.325	4.71	Jan. 04, 2023
5500	20	99	91.19	94.42	92.805	-6.26	Jan. 05, 2023
5500	20	99	102.8	103.4	103.1	4.14	Mar 31, 2023



10. Modulation Interference Factor

The HAC Standard ANSI C63.19-2011 defines a new scaling using the Modulation Interference Factor (MIF). For any specific fixed and repeatable modulated signal, a modulation interference factor (MIF, expressed in dB) may be developed that relates its interference potential to its steady-state rms signal level or average power level. This factor is a function only of the audio-frequency amplitude modulation characteristics of the signal and is the same for field-strength and conducted power measurements. It is important to emphasize that the MIF is valid only for a specific repeatable audio-frequency amplitude modulation characteristic. Any change in modulation characteristic requires determination and application of a new MIF

The Modulation Interference factor (MIF, in dB) is added to the measured average E-field (in dBV/m) and converts it to the RF Audio Interference level (in dBV/m). This level considers the audible amplitude modulation components in the RF E-field. CW fields without amplitude modulation are assumed to not interfere with the hearing aid electronics. Modulations without time slots and low fluctuations at low frequencies have low MIF values, TDMA modulations with narrow transmission and repetition rates of few 100 Hz have high MIF values and give similar classifications as ANSI C63.19-2011.

ER3D, EF3D and EU2D E-field probes have a bandwidth <10 kHz and can therefore not evaluate the RF envelope in the full audio band. DASY52 is therefore using the indirect measurement method according to ANSI C63.19-2011 which is the primary method. These near field probes read the averaged E-field measurement. Especially for the new high peak-to-average (PAR) signal types, the probes shall be linearized by PMR calibration in order to not overestimate the field reading. Probe Modulation Response (PMR) calibration linearizes the probe response over its dynamic range for specific modulations which are characterized by their UID and result in an uncertainty specified in the probe calibration certificate. The MIF is characteristic for a given waveform envelope and can be used as a constant conversion factor if the probe has been PMR calibrated.

The evaluation method for the MIF is defined in ANSI C63.19-2011 section D.7. An RMS demodulated RF signal is fed to a spectral filter (similar to an A weighting filter) and forwarded to a temporal filter acting as a quasi-peak detector. The averaged output of these filtering is scaled to a 1 kHz 80% AM signal as reference. MIF measurement requires additional instrumentation and is not well suited for evaluation by the end user with reasonable uncertainty. It may alternatively be determined through analysis and simulation, because it is constant and characteristic for a communication signal. DASY52 uses well-defined signals for PMR calibration. The MIF of these signals has been determined by simulation and it is automatically applied.

The MIF measurement uncertainty is estimated as follows, declared by HAC equipment provider SPEAG, for modulation frequencies from slotted waveforms with fundamental frequency and at least 2 harmonics within 10 kHz:

- 1. 0.2 dB for MIF: -7 to +5 dB
2. 0.5 dB for MIF: -13 to +11 dB
3. 1 dB for MIF: > -20 dB

MIF values applied in this test report were provided by the HAC equipment provider of SPEAG, and the worst values for all air interface are listed below to be determine the Low-power Exemption.

Table with 3 columns: UID, Communication System Name, MIF(dB). Rows include GSM-FDD, EDGE-FDD, UMTS-FDD, LTE-FDD, 5G NR, and IEEE WiFi standards.



11. Low-power Exemption

<Max Tune-up Limit>

- 1. The maximum tune-up power was conservatively used to evaluate low power exemption.
- 2. Since the device support TAS feature for LTE and FR1, thus HAC RF was evaluated at Pmax Power level.
- 3. GSM, WCDMA and WIFI doesn't support TAS feature, HAC RF was evaluated at standalone Power level .
corresponding power index as below table.

Air interface	Open mode	Close mode
	Power index	
GSM	Index 7	Index 2
WCDMA	Index 7	Index 2
WIFI	Index 7	Index 2



WWAN

<Closed mode / Open mode>

Radio Tech	Band Number	Average Power (dBm)				
		Ant 0	Ant 1	Ant 2	Ant 5	Ant 6
GSM/GPRS 1TX	850	33.50	33.50			
EGPRS 1TX	850	28.00	28.00			
GSM/GPRS 1TX	1900	31.00		31.00		
EGPRS 1TX	1900	26.00		26.00		
UMTS/HSPA	B2	25.20		25.20		
UMTS/HSPA	B4	25.70		25.70		
UMTS/HSPA	B5	25.00	25.00			
LTE	B2	25.70	25.70	25.70	25.70	
LTE	B4	25.70	25.70	25.70	25.70	
LTE	B5	25.70	25.70			
LTE	B7	25.70		25.70		
LTE	B12	25.70	25.70			
LTE	B13	25.70	25.70			
LTE	B14	25.70	25.70			
LTE	B17	25.70	25.70			
LTE	B25	25.70		25.70		
LTE	B26	25.70	25.70			
LTE	B30	23.70		23.70		
LTE	B38 PC3	25.70		25.70		
LTE	B38 PC2	27.40		27.40		
LTE	B41 PC3	25.40		25.40		
LTE	B41 PC2	27.40		27.40		
LTE	B48			25.20		25.70
LTE	B66	25.70	25.70	25.70	25.70	
LTE	B71	25.70	25.70			
5G FR1	n2	25.70	25.70	25.70	25.70	
5G FR1	n5	25.70	25.70			
5G FR1	n7	25.70		25.70		
5G FR1	n12	25.70	25.70			
5G FR1	n14	25.70	25.70			
5G FR1	n25	25.70		25.70		
5G FR1	n30	23.70		23.70		
5G FR1	n38 PC3	25.70	25.20	25.70	25.20	
5G FR1	n41 PC3	25.40	25.20	25.40	25.20	
5G FR1	n41 PC2	27.40	27.20	27.40	27.20	
5G FR1	n48 PC3		25.30	25.70	25.30	25.70
5G FR1	n66	25.70	25.70	25.70	25.70	
5G FR1	n71	25.70	25.70			
5G FR1	n77 PC3		25.30	25.10	25.30	25.10
5G FR1	n77 PC2			27.10		27.10



<Low Power Exemption>

WWAN

<Closed mode / Open mode>

General Note:

1. EDGE data mode test can be covered by GSM Voice mode, as GSM voice mode represents the worst case.
2. According to ANSI C63.19 2011-version, for the air interface technology of a device is exempt from testing when its average antenna input power plus its MIF is ≤ 17 dBm for any of its operating modes.
3. HAC RF rating is M4 for the air interface which meets the low power exemption.
4. The low power exemption was assessed by the each wireless air interface maximum power with each transmit antenna, and the air interface that was not exempted was further considered testing.
5. The maximum power was conservatively used to evaluate HAC RF testing.

Ant 0				
Air Interface	Max Average Antenna Input Power (dBm)	Worst Case MIF (dB)	Power + MIF(dB)	C63.19 test required
GSM850	33.50	3.63	37.13	Yes
EDGE850	28.00	3.75	31.75	Yes ⁽¹⁾
GSM1900	31.00	3.63	34.63	Yes
EDGE1900	26.00	3.75	29.75	Yes ⁽¹⁾
WCDMA	25.70	-25.43	0.27	No
WCDMA - HSPA	24.70	-20.39	4.31	No
LTE - FDD	25.70	-9.76	15.94	No
LTE – TDD_PC3	25.70	-1.44	24.26	Yes
LTE – TDD_PC2	27.40	-1.44	25.96	Yes
5G FR1 - FDD	25.70	-12.08	13.62	No
5G NR – TDD_PC3	25.70	-12.08	13.62	No
5G NR – TDD_PC2	27.40	-1.64	25.76	Yes

Ant 1				
Air Interface	Max Average Antenna Input Power (dBm)	Worst Case MIF (dB)	Power + MIF(dB)	C63.19 test required
GSM850	33.50	3.63	37.13	Yes
EDGE850	28.00	3.75	31.75	Yes ⁽¹⁾
WCDMA	25.00	-25.43	-0.43	No
WCDMA - HSPA	24.70	-20.39	4.31	No
LTE - FDD	25.70	-9.76	15.94	No
5G FR1 - FDD	25.70	-12.08	13.62	No
5G NR – TDD_PC3	25.30	-12.08	13.22	No
5G NR – TDD_PC2	27.20	-1.64	25.56	Yes

Ant 2				
Air Interface	Max Average Antenna Input Power (dBm)	Worst Case MIF (dB)	Power + MIF(dB)	C63.19 test required
GSM1900	31.00	3.63	34.63	Yes
EDGE1900	26.00	3.75	29.75	Yes ⁽¹⁾
WCDMA	25.70	-25.43	0.27	No
WCDMA - HSPA	24.70	-20.39	4.31	No
LTE - FDD	25.70	-9.76	15.94	No
LTE – TDD_PC3	25.70	-1.44	24.26	Yes
LTE – TDD_PC2	27.40	-1.44	25.96	Yes
5G FR1 - FDD	25.70	-12.08	13.62	No
5G NR - TDD_PC3	25.70	-12.08	13.62	No
5G NR - TDD_PC2	27.40	-1.64	25.76	Yes



Ant 5				
Air Interface	Max Average Antenna Input Power (dBm)	Worst Case MIF (dB)	Power + MIF(dB)	C63.19 test required
LTE - FDD	25.70	-9.76	15.94	No
5G FR1 - FDD	25.70	-12.08	13.62	No
5G NR – TDD_PC3	25.30	-12.08	13.22	No
5G NR – TDD_PC2	27.20	-1.64	25.56	Yes

Ant 6				
Air Interface	Max Average Antenna Input Power (dBm)	Worst Case MIF (dB)	Power + MIF(dB)	C63.19 test required
LTE – TDD	25.70	-1.44	24.26	Yes
5G NR - TDD_PC3	25.70	-12.08	13.62	No
5G NR - TDD_PC2	27.10	-1.64	25.46	Yes



WLAN

General Note:

1. According to ANSI C63.19 2011-version, for the air interface technology of a device is exempt from testing when its average antenna input power plus its MIF is ≤ 17 dBm for any of its operating modes.
2. HAC RF rating is M4 for the air interface which meets the low power exemption.
3. The low power exemption was assessed by the each wireless air interface maximum power with each transmit antenna when device operate in head mode, and the air interface that was not exempted was further considered testing.
4. The maximum power was conservatively used to evaluate HAC RF testing.

<Closed mode>

Antenna	Ant 3 / 4	Ant 3+4
2.4GHz WLAN	802.11b	21.00
	802.11g	
	802.11n-HT20	24.00
	802.11ac-VHT20	24.00
	802.11ax-HE20	24.00
5.2GHz	802.11a	22.50
	802.11n-HT20	23.00
	802.11n-HT40	23.00
	802.11ac-VHT20	23.00
	802.11ac-VHT40	23.00
	802.11ac-VHT80	19.00
	802.11ax-HE20	23.00
	802.11ax-HE40	23.00
5.3GHz	802.11a	22.50
	802.11n-HT20	23.00
	802.11n-HT40	23.00
	802.11ac-VHT20	23.00
	802.11ac-VHT40	23.00
	802.11ac-VHT80	19.50
	802.11ac-VHT160	16.50
	802.11ax-HE20	23.00
	802.11ax-HE40	23.00
	802.11ax-HE80	19.50
5.5GHz	802.11a	19.00
	802.11n-HT20	19.50
	802.11n-HT40	22.50
	802.11ac-VHT20	19.50
	802.11ac-VHT40	22.50
	802.11ac-VHT80	22.00
	802.11ac-VHT160	17.50
	802.11ax-HE20	19.50
	802.11ax-HE40	22.50
	802.11ax-HE80	22.00
802.11ax-HE160	17.50	



Antenna		Ant 3+4
5.8GHz	802.11a	20.50
	802.11n-HT20	20.50
	802.11n-HT40	21.50
	802.11ac-VHT20	20.50
	802.11ac-VHT40	21.50
	802.11ac-VHT80	23.00
	802.11ax-HE20	20.50
	802.11ax-HE40	21.50
5.9GHz	802.11a	20.00
	802.11n-HT20	20.50
	802.11n-HT40	21.50
	802.11ac-VHT20	20.50
	802.11ac-VHT40	21.50
	802.11ac-VHT80	23.00
	802.11ac-VHT160	23.00
	802.11ax-HE20	20.50
	802.11ax-HE40	21.50
	802.11ax-HE80	23.00
U-NII 5	802.11a	23.50
	802.11ax-HE20	22.50
	802.11ax-HE40	23.00

WLAN Ant 3 / 4					
Air Interface		Max Average Antenna Input Power (dBm)	Worst Case MIF (dB)	Power + MIF(dB)	C63.19 test required
2.4GHz	802.11b	21.00	-2.02	18.98	Yes

WLAN Ant 3+4					
Air Interface		Max Average Antenna Input Power (dBm)	Worst Case MIF (dB)	Power + MIF(dB)	C63.19 test required
2.4GHz	802.11g	24.00	0.12	24.12	Yes
	802.11n-HT20	24.00	-13.44	10.56	No
	802.11ac-VHT20	24.00	-5.57	18.43	Yes ⁽¹⁾
	802.11ax-HE20	24.00	-5.58	18.42	Yes ⁽¹⁾

General Note:

- 802.11ac-VHT20, 802.11ax-HE20 test can be covered by 802.11g, as 802.11g represents the worst case.

WLAN Ant 3+4					
Air Interface		Max Average Antenna Input Power (dBm)	Worst Case MIF (dB)	Power + MIF(dB)	C63.19 test required
5.2GHz	802.11a	22.50	-3.15	19.35	Yes
	802.11n-HT20	23.00	-13.44	9.56	No
	802.11n-HT40	23.00	-13.44	9.56	No
	802.11ac-VHT20	23.00	-5.57	17.43	Yes ⁽¹⁾
	802.11ac-VHT40	23.00	-5.57	17.43	Yes ⁽¹⁾
	802.11ac-VHT80	19.00	-5.57	13.43	No
	802.11ax-HE20	23.00	-5.58	17.42	Yes ⁽¹⁾
	802.11ax-HE40	23.00	-5.58	17.42	Yes ⁽¹⁾
	802.11ax-HE80	19.00	-5.58	13.42	No

General Note:

- 802.11ac-VHT20, 802.11ac-VHT40, 802.11ax-HE20, 802.11ax-HE40 test can be covered by 802.11a, as 802.11a represents the worst case.



WLAN Ant 3+4					
Air Interface		Max Average Antenna Input Power (dBm)	Worst Case MIF (dB)	Power + MIF(dB)	C63.19 test required
5.3GHz	802.11a	22.50	-3.15	19.35	Yes
	802.11n-HT20	23.00	-13.44	9.56	No
	802.11n-HT40	23.00	-13.44	9.56	No
	802.11ac-VHT20	23.00	-5.57	17.43	Yes ⁽¹⁾
	802.11ac-VHT40	23.00	-5.57	17.43	Yes ⁽¹⁾
	802.11ac-VHT80	19.50	-5.57	13.93	No
	802.11ac-VHT160	16.50	-5.57	10.93	No
	802.11ax-HE20	23.00	-5.58	17.42	Yes ⁽¹⁾
	802.11ax-HE40	23.00	-5.58	17.42	Yes ⁽¹⁾
	802.11ax-HE80	19.50	-5.58	13.92	No
802.11ax-HE160	16.50	-5.58	10.92	No	

General Note:

- 802.11ac-VHT20, 802.11ac-VHT40, 802.11ax-HE20, 802.11ax-HE40 test can be covered by 802.11a, as 802.11a represents the worst case.

WLAN Ant 3+4					
Air Interface		Max Average Antenna Input Power (dBm)	Worst Case MIF (dB)	Power + MIF(dB)	C63.19 test required
5.5GHz	802.11a	19.00	-3.15	15.85	No
	802.11n-HT20	19.50	-13.44	6.06	No
	802.11n-HT40	22.50	-13.44	9.06	No
	802.11ac-VHT20	19.50	-5.57	13.93	No
	802.11ac-VHT40	22.50	-5.57	16.93	No
	802.11ac-VHT80	22.00	-5.57	16.43	No
	802.11ac-VHT160	17.50	-5.57	11.93	No
	802.11ax-HE20	19.50	-5.58	13.92	No
	802.11ax-HE40	22.50	-5.58	16.92	No
	802.11ax-HE80	22.00	-5.58	16.42	No
802.11ax-HE160	17.50	-5.58	11.92	No	

WLAN Ant 3+4					
Air Interface		Max Average Antenna Input Power (dBm)	Worst Case MIF (dB)	Power + MIF(dB)	C63.19 test required
5.8GHz	802.11a	20.50	-3.15	17.35	Yes ⁽¹⁾
	802.11n-HT20	20.50	-13.44	7.06	No
	802.11n-HT40	21.50	-13.44	8.06	No
	802.11ac-VHT20	20.50	-5.57	14.93	No
	802.11ac-VHT40	21.50	-5.57	15.93	No
	802.11ac-VHT80	23.00	-5.57	17.43	Yes
	802.11ax-HE20	20.50	-5.58	14.92	No
	802.11ax-HE40	21.50	-5.58	15.92	No
	802.11ax-HE80	23.00	-5.58	17.42	Yes ⁽¹⁾

General Note:

- 802.11a, 802.11ax-HE80 test can be covered by 802.11ac-VHT80, as 802.11ac-VHT80 represents the worst case.



WLAN Ant 3+4					
Air Interface		Max Average Antenna Input Power (dBm)	Worst Case MIF (dB)	Power + MIF(dB)	C63.19 test required
5.9GHz	802.11a	20.00	-3.15	16.85	No
	802.11n-HT20	20.50	-13.44	7.06	No
	802.11n-HT40	21.50	-13.44	8.06	No
	802.11ac-VHT20	20.50	-5.57	14.93	No
	802.11ac-VHT40	21.50	-5.57	15.93	No
	802.11ac-VHT80	23.00	-5.57	17.43	Yes ⁽¹⁾
	802.11ac-VHT160	23.00	-5.57	17.43	Yes
	802.11ax-HE20	20.50	-5.58	14.92	No
	802.11ax-HE40	21.50	-5.58	15.92	No
	802.11ax-HE80	23.00	-5.58	17.42	Yes ⁽¹⁾
802.11ax-HE160	23.00	-5.58	17.42	Yes ⁽¹⁾	

General Note:

- 802.11ac-VHT80, 802.11ax-HE80, 802.11ax-HE160 test can be covered by 802.11ac-VHT160, as 802.11ac-VHT160 represents the worst case.

WLAN Ant 3+4					
Air Interface		Max Average Antenna Input Power (dBm)	Worst Case MIF (dB)	Power + MIF(dB)	C63.19 test required
U-NII 5	802.11a	23.50	-3.15	20.35	Yes ⁽¹⁾
	802.11ax-HE20	22.50	-5.58	16.92	No
	802.11ax-HE40	23.00	-5.58	17.42	Yes ⁽¹⁾

General Note:

- 802.11ax-HE40 test can be covered by 802.11a, as 802.11a represents the worst case.



<Open mode>

Antenna	Ant 3	Ant 4	Ant 3+4
2.4GHz WLAN	802.11b	15.50	21.00
	802.11g		22.10
	802.11n-HT20		22.10
	802.11ac-VHT20		22.10
	802.11ax-HE20		22.10
5.2GHz	802.11a		20.50
	802.11n-HT20		20.90
	802.11n-HT40		20.90
	802.11ac-VHT20		20.90
	802.11ac-VHT40		20.90
	802.11ac-VHT80		17.90
	802.11ax-HE20		20.90
	802.11ax-HE40		20.90
5.3GHz	802.11a		20.50
	802.11n-HT20		20.90
	802.11n-HT40		20.90
	802.11ac-VHT20		20.90
	802.11ac-VHT40		20.90
	802.11ac-VHT80		18.30
	802.11ac-VHT160		16.50
	802.11ax-HE20		20.90
	802.11ax-HE40		20.90
	802.11ax-HE80		18.30
5.5GHz	802.11a		17.80
	802.11n-HT20		18.10
	802.11n-HT40		20.40
	802.11ac-VHT20		18.10
	802.11ac-VHT40		20.40
	802.11ac-VHT80		20.00
	802.11ac-VHT160		16.80
	802.11ax-HE20		18.10
	802.11ax-HE40		20.40
	802.11ax-HE80		20.00
802.11ax-HE160		16.80	



Antenna	Ant 3+4	
5.8GHz	802.11a	19.10
	802.11n-HT20	19.10
	802.11n-HT40	19.80
	802.11ac-VHT20	19.10
	802.11ac-VHT40	19.80
	802.11ac-VHT80	21.00
	802.11ax-HE20	19.10
	802.11ax-HE40	19.80
5.9GHz	802.11a	18.80
	802.11n-HT20	19.10
	802.11n-HT40	19.80
	802.11ac-VHT20	19.10
	802.11ac-VHT40	19.80
	802.11ac-VHT80	21.00
	802.11ac-VHT160	21.00
	802.11ax-HE20	19.10
	802.11ax-HE40	19.80
	802.11ax-HE80	21.00
U-NII 5	802.11a	21.00
	802.11ax-HE20	21.00
	802.11ax-HE40	21.00



WLAN Ant 3					
Air Interface		Max Average Antenna Input Power (dBm)	Worst Case MIF (dB)	Power + MIF(dB)	C63.19 test required
2.4GHz	802.11b	15.50	-2.02	13.48	Yes

WLAN Ant 4					
Air Interface		Max Average Antenna Input Power (dBm)	Worst Case MIF (dB)	Power + MIF(dB)	C63.19 test required
2.4GHz	802.11b	21.00	-2.02	18.98	Yes

WLAN Ant 3+4					
Air Interface		Max Average Antenna Input Power (dBm)	Worst Case MIF (dB)	Power + MIF(dB)	C63.19 test required
2.4GHz	802.11g	22.10	0.12	22.22	Yes
	802.11n-HT20	22.10	-13.44	8.66	No
	802.11ac-VHT20	22.10	-5.57	16.53	No
	802.11ax-HE20	22.10	-5.58	16.52	No

WLAN Ant 3+4					
Air Interface		Max Average Antenna Input Power (dBm)	Worst Case MIF (dB)	Power + MIF(dB)	C63.19 test required
5.2GHz	802.11a	20.50	-3.15	17.35	Yes
	802.11n-HT20	20.90	-13.44	7.46	No
	802.11n-HT40	20.90	-13.44	7.46	No
	802.11ac-VHT20	20.90	-5.57	15.33	No
	802.11ac-VHT40	20.90	-5.57	15.33	No
	802.11ac-VHT80	17.90	-5.57	12.33	No
	802.11ax-HE20	20.90	-5.58	15.32	No
	802.11ax-HE40	20.90	-5.58	15.32	No
5.3GHz	802.11a	20.50	-3.15	17.35	Yes
	802.11n-HT20	20.90	-13.44	7.46	No
	802.11n-HT40	20.90	-13.44	7.46	No
	802.11ac-VHT20	20.90	-5.57	15.33	No
	802.11ac-VHT40	20.90	-5.57	15.33	No
	802.11ac-VHT80	18.30	-5.57	12.73	No
	802.11ac-VHT160	16.50	-5.57	10.93	No
	802.11ax-HE20	20.90	-5.58	15.32	No
	802.11ax-HE40	20.90	-5.58	15.32	No
	802.11ax-HE80	18.30	-5.58	12.72	No
5.5GHz	802.11a	17.80	-3.15	14.65	No
	802.11n-HT20	18.10	-13.44	4.66	No
	802.11n-HT40	20.40	-13.44	6.96	No
	802.11ac-VHT20	18.10	-5.57	12.53	No
	802.11ac-VHT40	20.40	-5.57	14.83	No
	802.11ac-VHT80	20.00	-5.57	14.43	No
	802.11ac-VHT160	16.80	-5.57	11.23	No
	802.11ax-HE20	18.10	-5.58	12.52	No
	802.11ax-HE40	20.40	-5.58	14.82	No
	802.11ax-HE80	20.00	-5.58	14.42	No
802.11ax-HE160	16.80	-5.58	11.22	No	



WLAN Ant 3+4					
Air Interface		Max Average Antenna Input Power (dBm)	Worst Case MIF (dB)	Power + MIF(dB)	C63.19 test required
5.8GHz	802.11a	19.10	-3.15	15.95	No
	802.11n-HT20	19.10	-13.44	5.66	No
	802.11n-HT40	19.80	-13.44	6.36	No
	802.11ac-VHT20	19.10	-5.57	13.53	No
	802.11ac-VHT40	19.80	-5.57	14.23	No
	802.11ac-VHT80	21.00	-5.57	15.43	No
	802.11ax-HE20	19.10	-5.58	13.52	No
	802.11ax-HE40	19.80	-5.58	14.22	No
5.9GHz	802.11a	18.80	-3.15	15.65	No
	802.11n-HT20	19.10	-13.44	5.66	No
	802.11n-HT40	19.80	-13.44	6.36	No
	802.11ac-VHT20	19.10	-5.57	13.53	No
	802.11ac-VHT40	19.80	-5.57	14.23	No
	802.11ac-VHT80	21.00	-5.57	15.43	No
	802.11ac-VHT160	21.00	-5.57	15.43	No
	802.11ax-HE20	19.10	-5.58	13.52	No
	802.11ax-HE40	19.80	-5.58	14.22	No
	802.11ax-HE80	21.00	-5.58	15.42	No
U-NII 5	802.11a	21.00	-3.15	17.85	Yes
	802.11ax-HE20	21.00	-5.58	15.42	No
	802.11ax-HE40	21.00	-5.58	15.42	No



12. Conducted RF Output Power (Unit: dBm)

<Closed mode>

<GSM850_Ant 0>

Band GSM850	Burst Average Power (dBm)		
TX Channel	128	189	251
Frequency (MHz)	824.2	836.4	848.8
GSM (GMSK, 1 Tx slot)	32.60	32.56	32.56

<GSM850_Ant 1>

Band GSM850	Burst Average Power (dBm)		
TX Channel	128	189	251
Frequency (MHz)	824.2	836.4	848.8
GSM (GMSK, 1 Tx slot)	32.77	32.82	32.81

<GSM1900_Ant 0>

Band GSM1900	Burst Average Power (dBm)		
TX Channel	512	661	810
Frequency (MHz)	1850.2	1880	1909.8
GSM (GMSK, 1 Tx slot)	30.15	29.88	30.26

<GSM1900_Ant 2>

Band GSM1900	Burst Average Power (dBm)		
TX Channel	512	661	810
Frequency (MHz)	1850.2	1880	1909.8
GSM (GMSK, 1 Tx slot)	30.03	29.87	30.22

<TDD LTE Band 41_Ant 0>

BW [MHz]	Modulation	RB Size	RB Offset	Power Low Ch. / Freq.	Power Low Middle Ch. / Freq.	Power Middle Ch. / Freq.	Power High Middle Ch. / Freq.	Power High Ch. / Freq.
Channel				39750	40185	40620	41055	41490
Frequency (MHz)				2506	2549.5	2593	2636.5	2680
20	QPSK	1	0	24.09	24.02	24.05	24.07	24.06

<TDD LTE Band 41_HPUE_Ant 0>

BW [MHz]	Modulation	RB Size	RB Offset	Power High Ch. / Freq.
Channel				41490
Frequency (MHz)				2680
20	QPSK	1	0	25.99

<TDD LTE Band 41_Ant 2>

BW [MHz]	Modulation	RB Size	RB Offset	Power Low Ch. / Freq.	Power Low Middle Ch. / Freq.	Power Middle Ch. / Freq.	Power High Middle Ch. / Freq.	Power High Ch. / Freq.
Channel				39750	40185	40620	41055	41490
Frequency (MHz)				2506	2549.5	2593	2636.5	2680
20	QPSK	1	0	24.31	24.27	24.35	24.25	24.12

<TDD LTE Band 41_HPUE_Ant 2>

BW [MHz]	Modulation	RB Size	RB Offset	Power Middle Ch. / Freq.
Channel				40620
Frequency (MHz)				2593
20	QPSK	1	0	26.29



<TDD LTE Band 48_Ant 2>

BW [MHz]	Modulation	RB Size	RB Offset	Power Low Ch. / Freq.	Power Low Middle Ch. / Freq.	Power High Middle Ch. / Freq.	Power High Ch. / Freq.
Channel				55340	55830	56150	56640
Frequency (MHz)				3560	3609	3641	3690
20	QPSK	1	0	24.37	24.48	24.68	24.45

<TDD LTE Band 48_Ant 6>

BW [MHz]	Modulation	RB Size	RB Offset	Power Low Ch. / Freq.	Power Low Middle Ch. / Freq.	Power High Middle Ch. / Freq.	Power High Ch. / Freq.
Channel				55340	55830	56150	56640
Frequency (MHz)				3560	3609	3641	3690
20	QPSK	1	0	25.11	24.86	25.08	25.20

<FR1_n41_HPUE_Ant 0>

BW [MHz]	Modulation	RB Size	RB Offset	Power Low Ch. / Freq.	Power Middle Ch. / Freq.	Power High Ch. / Freq.
Channel				509202	518598	528000
Frequency (MHz)				2546.01	2592.99	2640
100	PI/2 BPSK	1	1	26.21	26.13	26.21

<FR1_n41_HPUE_Ant 1>

BW [MHz]	Modulation	RB Size	RB Offset	Power Low Ch. / Freq.	Power Middle Ch. / Freq.	Power High Ch. / Freq.
Channel				509202	518598	528000
Frequency (MHz)				2546.01	2592.99	2640
100	PI/2 BPSK	1	1	26.11	26.01	25.93

<FR1_n41_HPUE_Ant 2>

BW [MHz]	Modulation	RB Size	RB Offset	Power Low Ch. / Freq.	Power Middle Ch. / Freq.	Power High Ch. / Freq.
Channel				509202	518598	528000
Frequency (MHz)				2546.01	2592.99	2640
100	PI/2 BPSK	1	1	26.55	26.56	26.56

<FR1_n41_HPUE_Ant 5>

BW [MHz]	Modulation	RB Size	RB Offset	Power Low Ch. / Freq.	Power Middle Ch. / Freq.	Power High Ch. / Freq.
Channel				509202	518598	528000
Frequency (MHz)				2546.01	2592.99	2640
100	PI/2 BPSK	1	1	25.45	25.53	25.51



<FR1_n77_270_HPUE_Ant 2>

BW [MHz]	Modulation	RB Size	RB Offset	Power Low Ch. / Freq.	Power Middle Ch. / Freq.	Power High Ch. / Freq.
Channel				650000	656000	662000
Frequency (MHz)				3750	3840	3930
100	PI/2 BPSK	1	1	25.85	25.42	25.56

<FR1_n77_27Q_HPUE_Ant 2>

BW [MHz]	Modulation	RB Size	RB Offset	Power Low Ch. / Freq.	Power Middle Ch. / Freq.	Power High Ch. / Freq.
Channel					633332	
Frequency (MHz)					3499.98	
100	PI/2 BPSK	1	1		25.35	

<FR1_n77_270_HPUE_Ant 6>

BW [MHz]	Modulation	RB Size	RB Offset	Power Low Ch. / Freq.	Power Middle Ch. / Freq.	Power High Ch. / Freq.
Channel				650000	656000	662000
Frequency (MHz)				3750	3840	3930
100	PI/2 BPSK	1	1	26.37	25.97	25.85

<FR1_n77_27Q_HPUE_Ant 6>

BW [MHz]	Modulation	RB Size	RB Offset	Power Low Ch. / Freq.	Power Middle Ch. / Freq.	Power High Ch. / Freq.
Channel					633332	
Frequency (MHz)					3499.98	
100	PI/2 BPSK	1	1		25.39	



<WLAN 2.4GHz_Ant 3>

2.4GHz WLAN	Mode	Channel	Frequency (MHz)	Average power (dBm)
	802.11g 6Mbps	1	2412	20.60
		6	2437	20.90
		11	2462	20.90

<WLAN 2.4GHz_Ant 4>

2.4GHz WLAN	Mode	Channel	Frequency (MHz)	Average power (dBm)
	802.11g 6Mbps	1	2412	20.50
		6	2437	20.50
		11	2462	20.50

<WLAN 2.4GHz_Ant 3+4>

2.4GHz WLAN	Mode	Channel	Frequency (MHz)	Average power (dBm)
	802.11g 6Mbps	1	2412	23.71
		6	2437	23.67
		11	2462	22.77

<WLAN 5/6GHz_Ant 3+4>

5.2GHz WLAN	Mode	Channel	Frequency (MHz)	Average power (dBm)
	802.11a 6Mbps	36	5180	19.77
		44	5220	21.82
		48	5240	20.46
5.3GHz WLAN	Mode	Channel	Frequency (MHz)	Average power (dBm)
	802.11a 6Mbps	52	5260	20.47
		60	5300	21.86
		64	5320	21.46
5.8GHz WLAN	Mode	Channel	Frequency (MHz)	Average power (dBm)
	802.11ac-VHT80 MCS0	155	5775	22.46
5.9GHz WLAN	Mode	Channel	Frequency (MHz)	Average power (dBm)
	802.11ac-VHT160 MCS0	163	5815	22.61
U-NII 5	Mode	Channel	Frequency (MHz)	Average power (dBm)
	802.11a 6Mbps	1	5955	22.87
		5	5975	22.65



<Open mode>

<GSM850_Ant 0>

Band GSM850	Burst Average Power (dBm)		
TX Channel	128	189	251
Frequency (MHz)	824.2	836.4	848.8
GSM (GMSK, 1 Tx slot)	32.60	32.56	32.56

<GSM850_Ant 1>

Band GSM850	Burst Average Power (dBm)		
TX Channel	128	189	251
Frequency (MHz)	824.2	836.4	848.8
GSM (GMSK, 1 Tx slot)	30.94	30.96	30.92

<GSM1900_Ant 0>

Band GSM1900	Burst Average Power (dBm)		
TX Channel	512	661	810
Frequency (MHz)	1850.2	1880	1909.8
GSM (GMSK, 1 Tx slot)	30.15	29.88	30.26

<GSM1900_Ant 2>

Band GSM1900	Burst Average Power (dBm)		
TX Channel	512	661	810
Frequency (MHz)	1850.2	1880	1909.8
GSM (GMSK, 1 Tx slot)	30.03	29.87	30.22

<TDD LTE Band 41_Ant 0>

BW [MHz]	Modulation	RB Size	RB Offset	Power Low Ch. / Freq.	Power Low Middle Ch. / Freq.	Power Middle Ch. / Freq.	Power High Middle Ch. / Freq.	Power High Ch. / Freq.
Channel				39750	40185	40620	41055	41490
Frequency (MHz)				2506	2549.5	2593	2636.5	2680
20	QPSK	1	0	24.09	24.02	24.05	24.07	24.06

<TDD LTE Band 41_HPUE_Ant 0>

BW [MHz]	Modulation	RB Size	RB Offset	Power High Ch. / Freq.
Channel				41490
Frequency (MHz)				2680
20	QPSK	1	0	25.99

<TDD LTE Band 41_Ant 2>

BW [MHz]	Modulation	RB Size	RB Offset	Power Low Ch. / Freq.	Power Low Middle Ch. / Freq.	Power Middle Ch. / Freq.	Power High Middle Ch. / Freq.	Power High Ch. / Freq.
Channel				39750	40185	40620	41055	41490
Frequency (MHz)				2506	2549.5	2593	2636.5	2680
20	QPSK	1	0	24.31	24.27	24.35	24.25	24.12

<TDD LTE Band 41_HPUE_Ant 2>

BW [MHz]	Modulation	RB Size	RB Offset	Power High Ch. / Freq.
Channel				41490
Frequency (MHz)				2680
20	QPSK	1	0	26.17



<TDD LTE Band 48_Ant 2>

BW [MHz]	Modulation	RB Size	RB Offset	Power Low Ch. / Freq.	Power Low Middle Ch. / Freq.	Power High Middle Ch. / Freq.	Power High Ch. / Freq.
Channel				55340	55830	56150	56640
Frequency (MHz)				3560	3609	3641	3690
20	QPSK	1	0	24.37	24.48	24.68	24.45

<TDD LTE Band 48_Ant 6>

BW [MHz]	Modulation	RB Size	RB Offset	Power Low Ch. / Freq.	Power Low Middle Ch. / Freq.	Power High Middle Ch. / Freq.	Power High Ch. / Freq.
Channel				55340	55830	56150	56640
Frequency (MHz)				3560	3609	3641	3690
20	QPSK	1	0	25.11	24.86	25.08	25.20

<FR1_n41_HPUE_Ant 0>

BW [MHz]	Modulation	RB Size	RB Offset	Power Low Ch. / Freq.	Power Middle Ch. / Freq.	Power High Ch. / Freq.
Channel				509202	518598	528000
Frequency (MHz)				2546.01	2592.99	2640
100	PI/2 BPSK	1	1	26.21	26.13	26.21

<FR1_n41_HPUE_Ant 1>

BW [MHz]	Modulation	RB Size	RB Offset	Power Low Ch. / Freq.	Power Middle Ch. / Freq.	Power High Ch. / Freq.
Channel				509202	518598	528000
Frequency (MHz)				2546.01	2592.99	2640
100	PI/2 BPSK	1	1	26.11	26.01	25.93

<FR1_n41_HPUE_Ant 2>

BW [MHz]	Modulation	RB Size	RB Offset	Power Low Ch. / Freq.	Power Middle Ch. / Freq.	Power High Ch. / Freq.
Channel				509202	518598	528000
Frequency (MHz)				2546.01	2592.99	2640
100	PI/2 BPSK	1	1	26.55	26.56	26.56

<FR1_n41_HPUE_Ant 5>

BW [MHz]	Modulation	RB Size	RB Offset	Power Low Ch. / Freq.	Power Middle Ch. / Freq.	Power High Ch. / Freq.
Channel				509202	518598	528000
Frequency (MHz)				2546.01	2592.99	2640
100	PI/2 BPSK	1	1	25.45	25.53	25.51



<FR1_n77_270_HPUE_Ant 2>

BW [MHz]	Modulation	RB Size	RB Offset	Power Low Ch. / Freq.	Power Middle Ch. / Freq.	Power High Ch. / Freq.
Channel				650000	656000	662000
Frequency (MHz)				3750	3840	3930
100	PI/2 BPSK	1	1	25.85	25.42	25.56

<FR1_n77_27Q_HPUE_Ant 2>

BW [MHz]	Modulation	RB Size	RB Offset	Power Low Ch. / Freq.	Power Middle Ch. / Freq.	Power High Ch. / Freq.
Channel					633332	
Frequency (MHz)					3499.98	
100	PI/2 BPSK	1	1		25.35	

<FR1_n77_270_HPUE_Ant 6>

BW [MHz]	Modulation	RB Size	RB Offset	Power Low Ch. / Freq.	Power Middle Ch. / Freq.	Power High Ch. / Freq.
Channel				650000	656000	662000
Frequency (MHz)				3750	3840	3930
100	PI/2 BPSK	1	1	26.37	25.97	25.85

<FR1_n77_27Q_HPUE_Ant 6>

BW [MHz]	Modulation	RB Size	RB Offset	Power Low Ch. / Freq.	Power Middle Ch. / Freq.	Power High Ch. / Freq.
Channel					633332	
Frequency (MHz)					3499.98	
100	PI/2 BPSK	1	1		25.39	



<WLAN 2.4GHz_Ant 3>

2.4GHz WLAN	Mode	Channel	Frequency (MHz)	Average power (dBm)
	802.11g 6Mbps	1	2412	14.30
		6	2437	14.20
		11	2462	14.50

<WLAN 2.4GHz_Ant 4>

2.4GHz WLAN	Mode	Channel	Frequency (MHz)	Average power (dBm)
	802.11g 6Mbps	1	2412	20.50
		6	2437	20.50
		11	2462	20.50

<WLAN 2.4GHz_Ant 3+4>

2.4GHz WLAN	Mode	Channel	Frequency (MHz)	Average power (dBm)
	802.11g 6Mbps	1	2412	21.62
		6	2437	21.69
		11	2462	21.24

<WLAN 5/6GHz_Ant 3+4>

5.2GHz WLAN	Mode	Channel	Frequency (MHz)	Average power (dBm)
	802.11a 6Mbps	36	5180	18.03
		44	5220	19.81
		48	5240	18.62
5.3GHz WLAN	Mode	Channel	Frequency (MHz)	Average power (dBm)
	802.11a 6Mbps	52	5260	18.59
		60	5300	19.71
		64	5320	19.51
U-NII 5	Mode	Channel	Frequency (MHz)	Average power (dBm)
	802.11a 6Mbps	1	5955	20.30
		5	5975	20.10



13. HAC RF Emission Test Results

Plot No.	Air Interface	Modulation / Mode	Channel	DUT Status	Transmit Ant.	Average Antenna Input Power (dBm)	MIF	E-Field (dBV/m)	Margin to FCC M3 limit (dB)	E-Field M Rating
1	GSM850	Voice	128	Closed mode	Ant 0	32.60	3.63	38.79	6.21	M4
2	GSM850	Voice	189	Closed mode	Ant 0	32.56	3.63	38.58	6.42	M4
3	GSM850	Voice	251	Closed mode	Ant 0	32.56	3.63	37.52	7.48	M4
4	GSM850	Voice	128	Closed mode	Ant 1	32.77	3.63	39.15	5.85	M4
5	GSM850	Voice	189	Closed mode	Ant 1	32.82	3.63	38.09	6.91	M4
6	GSM850	Voice	251	Closed mode	Ant 1	32.81	3.63	36.93	8.07	M4
7	GSM1900	Voice	512	Closed mode	Ant 2	30.03	3.63	28.89	6.11	M4
8	GSM1900	Voice	661	Closed mode	Ant 2	29.87	3.63	28.59	6.41	M4
9	GSM1900	Voice	810	Closed mode	Ant 2	30.22	3.63	28.30	6.70	M4
10	GSM1900	Voice	512	Closed mode	Ant 0	30.15	3.63	32.07	2.93	M3
11	GSM1900	Voice	661	Closed mode	Ant 0	29.88	3.63	32.29	2.71	M3
12	GSM1900	Voice	810	Closed mode	Ant 0	30.26	3.63	30.29	4.71	M3
13	LTE Band 41	20M_QPSK_1_0	39750	Closed mode	Ant 2	24.31	-1.44	21.52	13.48	M4
14	LTE Band 41	20M_QPSK_1_0	40620	Closed mode	Ant 2	24.35	-1.44	22.43	12.57	M4
15	LTE Band 41	20M_QPSK_1_0	41490	Closed mode	Ant 2	24.12	-1.44	22.43	12.57	M4
16	LTE Band 41_HPUE	20M_QPSK_1_0	40620	Closed mode	Ant 2	26.29	-1.44	22.48	12.52	M4
17	LTE Band 41	20M_QPSK_1_0	39750	Closed mode	Ant 0	24.09	-1.44	19.84	15.16	M4
18	LTE Band 41	20M_QPSK_1_0	40620	Closed mode	Ant 0	24.05	-1.44	22.07	12.93	M4
19	LTE Band 41	20M_QPSK_1_0	41490	Closed mode	Ant 0	24.06	-1.44	22.08	12.92	M4
20	LTE Band 41_HPUE	20M_QPSK_1_0	41490	Closed mode	Ant 0	25.99	-1.44	22.04	12.96	M4
21	LTE Band 48	20M_QPSK_1_0	55340	Closed mode	Ant 6	25.11	-1.44	19.40	15.60	M4
22	LTE Band 48	20M_QPSK_1_0	55830	Closed mode	Ant 6	24.86	-1.44	18.97	16.03	M4
23	LTE Band 48	20M_QPSK_1_0	56640	Closed mode	Ant 6	25.20	-1.44	18.23	16.77	M4
24	LTE Band 48	20M_QPSK_1_0	55340	Closed mode	Ant 2	24.37	-1.44	21.36	13.64	M4
25	LTE Band 48	20M_QPSK_1_0	55830	Closed mode	Ant 2	24.48	-1.44	21.50	13.50	M4
26	LTE Band 48	20M_QPSK_1_0	56640	Closed mode	Ant 2	24.45	-1.44	21.80	13.20	M4
27	FR1_n41_HPUE	100M_BPSK_1_1	518598	Closed mode	Ant 2	26.56	-1.64	22.87	12.13	M4
28	FR1_n41_HPUE	100M_BPSK_1_1	518598	Closed mode	Ant 0	26.13	-1.64	23.65	11.35	M4
29	FR1_n41_HPUE	100M_BPSK_1_1	518598	Closed mode	Ant 1	26.01	-1.64	26.06	8.94	M4
30	FR1_n41_HPUE	100M_BPSK_1_1	518598	Closed mode	Ant 5	25.53	-1.64	13.13	21.87	M4
31	FR1_n77_27O_HPUE	100M_BPSK_1_1	656000	Closed mode	Ant 6	25.97	-1.64	21.94	13.06	M4
32	FR1_n77_27Q_HPUE	100M_BPSK_1_1	633332	Closed mode	Ant 6	25.39	-1.64	22.12	12.88	M4
33	FR1_n77_27O_HPUE	100M_BPSK_1_1	656000	Closed mode	Ant 2	25.42	-1.64	21.74	13.26	M4
34	FR1_n77_27Q_HPUE	100M_BPSK_1_1	633332	Closed mode	Ant 2	25.35	-1.64	19.59	15.41	M4



Plot No.	Air Interface	Modulation / Mode	Channel	DUT Status	Transmit Ant.	Average Antenna Input Power (dBm)	MIF	E-Field (dBV/m)	Margin to FCC M3 limit (dB)	E-Field M Rating
35	WLAN2.4GHz	802.11b 1Mbps	1	Closed mode	Ant 3	20.60	-2.02	28.27	6.73	M4
36	WLAN2.4GHz	802.11b 1Mbps	6	Closed mode	Ant 3	20.90	-2.02	30.16	4.84	M3
37	WLAN2.4GHz	802.11b 1Mbps	11	Closed mode	Ant 3	20.90	-2.02	31.47	3.53	M3
38	WLAN2.4GHz	802.11b 1Mbps	1	Closed mode	Ant 4	20.50	-2.02	18.77	16.23	M4
39	WLAN2.4GHz	802.11b 1Mbps	6	Closed mode	Ant 4	20.50	-2.02	19.09	15.91	M4
40	WLAN2.4GHz	802.11b 1Mbps	11	Closed mode	Ant 4	20.50	-2.02	18.85	16.15	M4
41	WLAN2.4GHz	802.11g 6Mbps	1	Closed mode	Ant 3+4	23.71	0.12	30.69	4.31	M3
42	WLAN2.4GHz	802.11g 6Mbps	6	Closed mode	Ant 3+4	23.67	0.12	32.20	2.80	M3
43	WLAN2.4GHz	802.11g 6Mbps	11	Closed mode	Ant 3+4	22.77	0.12	32.54	2.46	M3
44	WLAN5GHz	802.11a 6Mbps	36	Closed mode	Ant 3+4	19.77	-3.15	22.59	12.41	M4
45	WLAN5GHz	802.11a 6Mbps	44	Closed mode	Ant 3+4	21.82	-3.15	23.07	11.93	M4
46	WLAN5GHz	802.11a 6Mbps	48	Closed mode	Ant 3+4	20.46	-3.15	22.89	12.11	M4
47	WLAN5GHz	802.11a 6Mbps	52	Closed mode	Ant 3+4	20.47	-3.15	22.85	12.15	M4
48	WLAN5GHz	802.11a 6Mbps	60	Closed mode	Ant 3+4	21.86	-3.15	24.26	10.74	M4
49	WLAN5GHz	802.11a 6Mbps	64	Closed mode	Ant 3+4	21.46	-3.15	23.01	11.99	M4
50	WLAN5GHz	802.11ac-VHT80 MCS0	155	Closed mode	Ant 3+4	22.46	-5.57	22.21	12.79	M4
51	WLAN5GHz	802.11ac-VHT160 MCS0	163	Closed mode	Ant 3+4	22.61	-5.57	21.74	13.26	M4
101	U-NII 5	802.11a 6Mbps	1	Closed mode	Ant 3+4	22.87	-3.15	25.28	9.72	M4
102	U-NII 5	802.11a 6Mbps	5	Closed mode	Ant 3+4	22.65	-3.15	25.11	9.87	M4



Plot No.	Air Interface	Modulation / Mode	Channel	DUT Status	Transmit Ant.	Average Antenna Input Power (dBm)	MIF	E-Field (dBV/m)	Margin to FCC M3 limit (dB)	E-Field M Rating
52	GSM850	Voice	128	Open mode	Ant 0	32.60	3.63	37.32	7.68	M4
53	GSM850	Voice	189	Open mode	Ant 0	32.56	3.63	38.15	6.85	M4
54	GSM850	Voice	251	Open mode	Ant 0	32.56	3.63	38.42	6.58	M4
55	GSM850	Voice	128	Open mode	Ant 1	30.94	3.63	31.11	13.89	M4
56	GSM850	Voice	189	Open mode	Ant 1	30.96	3.63	31.23	13.77	M4
57	GSM850	Voice	251	Open mode	Ant 1	30.92	3.63	32.43	12.57	M4
58	GSM1900	Voice	512	Open mode	Ant 2	30.03	3.63	28.86	6.14	M4
59	GSM1900	Voice	661	Open mode	Ant 2	29.87	3.63	26.37	8.63	M4
60	GSM1900	Voice	810	Open mode	Ant 2	30.22	3.63	23.91	11.09	M4
61	GSM1900	Voice	512	Open mode	Ant 0	30.15	3.63	26.07	8.93	M4
62	GSM1900	Voice	661	Open mode	Ant 0	29.88	3.63	22.68	12.32	M4
63	GSM1900	Voice	810	Open mode	Ant 0	30.26	3.63	20.84	14.16	M4
64	LTE Band 41	20M_QPSK_1_0	39750	Open mode	Ant 2	24.31	-1.44	20.67	14.33	M4
65	LTE Band 41	20M_QPSK_1_0	40620	Open mode	Ant 2	24.35	-1.44	21.47	13.53	M4
66	LTE Band 41	20M_QPSK_1_0	41490	Open mode	Ant 2	24.12	-1.44	22.34	12.66	M4
67	LTE Band 41_HPUE	20M_QPSK_1_0	41490	Open mode	Ant 2	26.17	-1.44	22.61	12.39	M4
68	LTE Band 41	20M_QPSK_1_0	39750	Open mode	Ant 0	24.09	-1.44	14.47	20.53	M4
69	LTE Band 41	20M_QPSK_1_0	40620	Open mode	Ant 0	24.05	-1.44	15.05	19.95	M4
70	LTE Band 41	20M_QPSK_1_0	41490	Open mode	Ant 0	24.06	-1.44	15.76	19.24	M4
71	LTE Band 41_HPUE	20M_QPSK_1_0	41490	Open mode	Ant 0	25.99	-1.44	16.06	18.94	M4
72	LTE Band 48	20M_QPSK_1_0	55340	Open mode	Ant 6	25.11	-1.44	19.28	15.72	M4
73	LTE Band 48	20M_QPSK_1_0	55830	Open mode	Ant 6	24.86	-1.44	20.06	14.94	M4
74	LTE Band 48	20M_QPSK_1_0	56640	Open mode	Ant 6	25.20	-1.44	20.91	14.09	M4
75	LTE Band 48	20M_QPSK_1_0	55340	Open mode	Ant 2	24.37	-1.44	19.68	15.32	M4
76	LTE Band 48	20M_QPSK_1_0	55830	Open mode	Ant 2	24.48	-1.44	20.43	14.57	M4
77	LTE Band 48	20M_QPSK_1_0	56640	Open mode	Ant 2	24.45	-1.44	20.37	14.63	M4
78	FR1_n41_HPUE	100M_BPSK_1_1	518598	Open mode	Ant 2	26.56	-1.64	22.45	12.55	M4
79	FR1_n41_HPUE	100M_BPSK_1_1	518598	Open mode	Ant 0	26.13	-1.64	13.60	21.40	M4
80	FR1_n41_HPUE	100M_BPSK_1_1	518598	Open mode	Ant 1	26.01	-1.64	28.07	6.93	M4
81	FR1_n41_HPUE	100M_BPSK_1_1	518598	Open mode	Ant 5	25.53	-1.64	11.18	23.82	M4
82	FR1_n77_27O_HPUE	100M_BPSK_1_1	656000	Open mode	Ant 6	25.97	-1.64	22.20	12.80	M4
83	FR1_n77_27Q_HPUE	100M_BPSK_1_1	633332	Open mode	Ant 6	25.39	-1.64	18.74	16.26	M4
84	FR1_n77_27O_HPUE	100M_BPSK_1_1	656000	Open mode	Ant 2	25.42	-1.64	19.99	15.01	M4
85	FR1_n77_27Q_HPUE	100M_BPSK_1_1	633332	Open mode	Ant 2	25.35	-1.64	19.50	15.50	M4



Plot No.	Air Interface	Modulation / Mode	Channel	DUT Status	Transmit Ant.	Average Antenna Input Power (dBm)	MIF	E-Field (dBV/m)	Margin to FCC M3 limit (dB)	E-Field M Rating
86	WLAN2.4GHz	802.11b 1Mbps	1	Open mode	Ant 3	14.30	-2.02	19.80	15.20	M4
87	WLAN2.4GHz	802.11b 1Mbps	6	Open mode	Ant 3	14.20	-2.02	20.68	14.32	M4
88	WLAN2.4GHz	802.11b 1Mbps	11	Open mode	Ant 3	14.50	-2.02	21.49	13.51	M4
89	WLAN2.4GHz	802.11b 1Mbps	1	Open mode	Ant 4	20.50	-2.02	18.82	16.18	M4
90	WLAN2.4GHz	802.11b 1Mbps	6	Open mode	Ant 4	20.50	-2.02	18.93	16.07	M4
91	WLAN2.4GHz	802.11b 1Mbps	11	Open mode	Ant 4	20.50	-2.02	18.22	16.78	M4
92	WLAN2.4GHz	802.11g 6Mbps	1	Open mode	Ant 3+4	21.62	0.12	24.83	10.17	M4
93	WLAN2.4GHz	802.11g 6Mbps	6	Open mode	Ant 3+4	21.69	0.12	24.90	10.10	M4
94	WLAN2.4GHz	802.11g 6Mbps	11	Open mode	Ant 3+4	21.24	0.12	25.07	9.93	M4
95	WLAN5GHz	802.11a 6Mbps	36	Open mode	Ant 3+4	18.03	-3.15	20.38	14.62	M4
96	WLAN5GHz	802.11a 6Mbps	44	Open mode	Ant 3+4	19.81	-3.15	21.16	13.84	M4
97	WLAN5GHz	802.11a 6Mbps	48	Open mode	Ant 3+4	18.62	-3.15	19.84	15.16	M4
98	WLAN5GHz	802.11a 6Mbps	52	Open mode	Ant 3+4	18.59	-3.15	19.77	15.23	M4
99	WLAN5GHz	802.11a 6Mbps	60	Open mode	Ant 3+4	19.71	-3.15	19.11	15.89	M4
100	WLAN5GHz	802.11a 6Mbps	64	Open mode	Ant 3+4	19.51	-3.15	19.18	15.82	M4
103	U-NII 5	802.11a 6Mbps	1	Open mode	Ant 3+4	20.30	-3.15	19.88	15.12	M4
104	U-NII 5	802.11a 6Mbps	5	Open mode	Ant 3+4	20.10	-3.15	19.45	15.55	M4

Remark:

1. The HAC measurement system applies MIF value onto the measured RMS E-field, which is indirect method in ANSI C63.19 2011 version, and reports the RF audio interference level.
2. Phone Condition: Mute on; Backlight off; Max Volume
3. The TDD power class 2 was spot check worst case configuration from power class3 to ensure the M rating also compliance.

Test Engineer : Carter Jhuang and EN Liu



14. Uncertainty Assessment

The component of uncertainty may generally be categorized according to the methods used to evaluate them. The evaluation of uncertainty by the statistical analysis of a series of observations is termed a Type A evaluation of uncertainty. The evaluation of uncertainty by means other than the statistical analysis of a series of observation is termed a Type B evaluation of uncertainty. Each component of uncertainty, however evaluated, is represented by an estimated standard deviation, termed standard uncertainty, which is determined by the positive square root of the estimated variance.

The combined standard uncertainty of the measurement result represents the estimated standard deviation of the result. It is obtained by combining the individual standard uncertainties of both Type A and Type B evaluation using the usual “root-sum-squares” (RSS) methods of combining standard deviations by taking the positive square root of the estimated variances. Expanded uncertainty is a measure of uncertainty that defines an interval about the measurement result within which the measured value is confidently believed to lie. It is obtained by multiplying the combined standard uncertainty by a coverage factor. For purpose of this document, a coverage factor two is used, which corresponds to confidence interval of about 95 %. The DASY uncertainty Budget is showed in Table 12.1.

The judgment of conformity in the report is based on the measurement results excluding the measurement uncertainty.

Error Description	Uncertainty Value (±%)	Probability Distribution	Divisor	Ci (E)	Standard Uncertainty (E)
Measurement System					
Probe Calibration	5.1	Normal	1	1	± 5.1 %
Axial Isotropy	4.7	Rectangular	√3	1	± 2.7 %
Sensor Displacement	16.5	Rectangular	√3	1	± 9.5 %
Boundary Effects	2.4	Rectangular	√3	1	± 1.4 %
Phantom Boundary Effects	7.2	Rectangular	√3	1	± 4.1 %
Linearity	4.7	Rectangular	√3	1	± 2.7 %
Scaling with PMR Calibration	10.0	Rectangular	√3	1	± 5.77 %
System Detection Limit	1.0	Rectangular	√3	1	± 0.6 %
Readout Electronics	0.3	Normal	1	1	± 0.3 %
Response Time	0.8	Rectangular	√3	1	± 0.5 %
Integration Time	2.6	Rectangular	√3	1	± 1.5 %
RF Ambient Conditions	3.0	Rectangular	√3	1	± 1.7 %
RF Reflections	12.0	Rectangular	√3	1	± 6.9 %
Probe Positioner	1.2	Rectangular	√3	1	± 0.7 %
Probe Positioning	4.7	Rectangular	√3	1	± 2.7 %
Extrap. and Interpolation	1.0	Rectangular	√3	1	± 0.6 %
Test Sample Related					
Device Positioning Vertical	4.7	Rectangular	√3	1	± 2.7 %
Device Positioning Lateral	1.0	Rectangular	√3	1	± 0.6 %
Device Holder and Phantom	2.4	Rectangular	√3	1	± 1.4 %
Power Drift	5.0	Rectangular	√3	1	± 2.9 %
Phantom and Setup Related					
Phantom Thickness	2.4	Rectangular	√3	1	± 1.4 %
Combined Standard Uncertainty					± 16.30 %
Coverage Factor for 95 %					K = 2
Expanded Std. Uncertainty on Power					± 32.6 %
Expanded Std. Uncertainty on Field					± 16.3 %
Declaration of Conformity: The test results with all measurement uncertainty excluded are presented in accordance with the regulation limits or requirements declared by manufacturers.					
Comments and Explanations: The declared of product specification for EUT presented in the report are provided by the manufacturer, and the manufacturer takes all the responsibilities for the accuracy of product specification.					

Uncertainty Budget of HAC free field assessment



15. References

- [1] ANSI C63.19-2011, "American National Standard for Methods of Measurement of Compatibility between Wireless Communications Devices and Hearing Aids", 27 May 2011.
- [2] FCC KDB 285076 D01v06r02, "Equipment Authorization Guidance for Hearing Aid Compatibility", Sep. 2022.
- [3] FCC KDB 285076 D03v01r06, "Hearing aid compatibility frequently asked questions", Jul. 2022
- [4] SPEAG DASY System Handbook