



FCC RADIO TEST REPORT

FCC ID : A4RG9FPL
Equipment : Phone
Model Name : G9FPL, G0B96
Applicant : Google LLC
1600 Amphitheatre Parkway,
Mountain View, California, 94043 USA
Standard : FCC 47 CFR Part 2, 27

The product was received on Nov. 23, 2022 and testing was performed from Nov. 23, 2022 to Jan. 18, 2023. We, Sporton International Inc. EMC & Wireless Communications Laboratory, would like to declare that the tested sample has been evaluated in accordance with the test procedures given in ANSI / TIA-603-E and has been in compliance with the applicable technical standards.

The test results in this report apply exclusively to the tested model / sample. Without written approval of Sporton International Inc. EMC & Wireless Communications Laboratory, the test report shall not be reproduced except in full.

Louis Wu

Approved by: Louis Wu

Sporton International Inc. EMC & Wireless Communications Laboratory

No. 52, Huaya 1st Rd., Guishan Dist., Taoyuan City 333, Taiwan (R.O.C.)



Table of Contents

History of this test report.....	3
Summary of Test Result.....	4
1 General Description	5
1.1 Product Feature of Equipment Under Test.....	5
1.2 Product Specification of Equipment Under Test.....	6
1.3 Modification of EUT	7
1.4 Testing Location	8
1.5 Applicable Standards.....	8
2 Test Configuration of Equipment Under Test	9
2.1 Test Mode.....	9
2.2 Connection Diagram of Test System.....	10
2.3 Support Unit used in test configuration and system	10
2.4 Measurement Results Explanation Example.....	11
2.5 Frequency List of Low/Middle/High Channels	12
3 Conducted Test Items.....	13
3.1 Measuring Instruments	13
3.2 Conducted Output Power and EIRP.....	14
3.3 Peak-to-Average Ratio	15
3.4 Occupied Bandwidth.....	16
3.5 Conducted Band Edge	17
3.6 Conducted Spurious Emission	18
3.7 Frequency Stability	19
4 Radiated Test Items	20
4.1 Measuring Instruments	20
4.2 Radiated Spurious Emission Measurement	22
5 List of Measuring Equipment.....	23
6 Uncertainty of Evaluation.....	25
Appendix A. Test Results of Conducted Test	
Appendix B. Test Results of Radiated Test	
Appendix C. Test Setup Photographs	



History of this test report

Report No.	Version	Description	Issue Date
FG262403-04F	01	Initial issue of report	Mar. 03, 2023
FG262403-04F	02	1. Revise Comments and Explanations, Antenna Type and Test Mode 2. Revise Appendix A1-5 and Appendix B	Mar. 07, 2023



Summary of Test Result

Report Clause	Ref Std. Clause	Test Items	Result (PASS/FAIL)	Remark
3.2	§2.1046	Conducted Output Power	Reporting only	-
	§27.50 (j)(3)	Equivalent Isotropic Radiated Power (n77)	Pass	
3.3	§27.50 (j)(4)	Peak-to-Average Ratio	Pass	-
3.4	§2.1049	Occupied Bandwidth	Reporting only	-
3.5	§2.1051 §27.53 (l)(2)	Conducted Band Edge Measurement (n77)	Pass	-
3.6	§2.1051 §27.53 (l)(2)	Conducted Spurious Emission (n77)	Pass	-
3.7	§2.1055 §27.54	Frequency Stability Temperature & Voltage	Pass	-
4.2	§2.1051 §27.53 (l)(2)	Radiated Spurious Emission (n77)	Pass	15.13 dB under the limit at 14805.000 MHz for Primary Antenna 13.34 dB under the limit at 7763.000 MHz for ASDIV Antenna

Declaration of Conformity:

- The test results (PASS/FAIL) with all measurement uncertainty excluded are presented in accordance with the regulation limits or requirements declared by manufacturers. It's means measurement values may risk exceeding the limit of regulation standards, if measurement uncertainty is include in test results.
- The measurement uncertainty please refer to report "Uncertainty of Evaluation".

Comments and Explanations:

- The product specifications of the EUT presented in the report are declared by the manufacturer who shall take full responsibility for the authenticity.
- The G9FPL and G0B96 are 100% identical in Hardware / Software to each other, and only have different model names for separate marketing purposes. The test samples are all model G9FPL.

Reviewed by: William Chen

Report Producer: Clio Lo



1 General Description

1.1 Product Feature of Equipment Under Test

Product Feature	
Equipment	Phone
Model Name	G9FPL, G0B96
FCC ID	A4RG9FPL
EUT supports Radios application	GSM/EGPRS/WCDMA/HSPA/LTE/5G NR/NFC/GNSS/ UWB/WPT Client WLAN 11b/g/n HT20 WLAN 11a/n HT20/HT40 WLAN 11ac VHT20/VHT40/VHT80/VHT160 WLAN 11ax HE20/HE40/HE80/HE160 Bluetooth BR/EDR/LE

Remark: The above EUT's information was declared by manufacturer.

EUT Information List	
S/N	Performed Test Item
2A311FDHS0000H	Conducted Measurement EIRP
2B071FDHS0000D	Radiated Spurious Emission



1.2 Product Specification of Equipment Under Test

Product Specification is subject to this standard	
Tx Frequency	5G NR n77: 3705 MHz ~ 3975 MHz
Rx Frequency	5G NR n77: 3705 MHz ~ 3975 MHz
Bandwidth	5G NR n77: 10MHz / 15MHz / 20MHz / 25MHz / 30MHz / 40MHz / 50MHz / 60MHz / 70MHz / 80MHz / 90MHz / 100MHz
Maximum Output Power to Antenna	<Primary Antenna> : 5G NR n77: 24.52 dBm 5G NR n77: 26.20 dBm for HPUE <ASDIV Antenna> : 5G NR n77: 24.54 dBm 5G NR n77: 25.37 dBm for HPUE <MIMO> MIMO n77 <Ant. 6+1>: 26.24 dBm
Antenna Type	<Primary Antenna> : <Ant. 6> : IFA Antenna <ASDIV Antenna> : <Ant. 2> : ILA Antenna <SRS diversity Antenna > : <Ant. 1> : ILA Antenna <Ant. 5> : PILA Antenna
Type of Modulation	PI/2 BPSK / QPSK / 16QAM / 64QAM / 256QAM



<Open Mode>

<Primary Antenna>

Radio Tech	Band Number	Antenna name	Gain
5G NR	n77	ANT6	-2.80

<ASDIV Antenna>

Radio Tech	Band Number	Antenna name	Gain
5G NR	n77	ANT2	-2.46

<SRS diversity Antenna>

Radio Tech	Band Number	Antenna name	Gain
5G NR	n77	ANT1	-4.69
5G NR	n77	ANT5	-8.39

<Close Mode>

<Primary Antenna>

Radio Tech	Band Number	Antenna name	Gain
5G NR	n77	ANT6	-4.38

<ASDIV Antenna>

Radio Tech	Band Number	Antenna name	Gain
5G NR	n77	ANT2	-5.42

<SRS diversity Antenna>

Radio Tech	Band Number	Antenna name	Gain
5G NR	n77	ANT1	-6.32
5G NR	n77	ANT5	-7.79

Remark: The above EUT's information was declared by manufacturer. Please refer to Comments and Explanations in report summary.

1.3 Modification of EUT

No modifications are made to the EUT during all test items.



1.4 Testing Location

Test Site	Sporton International Inc. EMC & Wireless Communications Laboratory
Test Site Location	No.52, Huaya 1st Rd., Guishan Dist., Taoyuan City 333, Taiwan (R.O.C.) TEL: +886-3-327-3456 FAX: +886-3-328-4978
Test Site No.	Sporton Site No. TH03-HY
Test Engineer	George Chen and Luffy Lin
Temperature (°C)	23.3~24.6
Relative Humidity (%)	47~52

Test Site	Sporton International Inc. Wensan Laboratory.
Test Site Location	No.58, Aly. 75, Ln. 564, Wenhua 3rd, Rd., Guishan Dist., Taoyuan City 333010, Taiwan (R.O.C.) TEL: +886-3-327-0868 FAX: +886-3-327-0855
Test Site No.	Sporton Site No. 03CH12-HY (TAF Code: 3786)
Test Engineer	Jesse Fan, Tim Lee and Wilson Wu
Temperature (°C)	20~25
Relative Humidity (%)	50~60
Remark	The Radiated Spurious Emission test item subcontracted to Sporton International Inc. Wensan Laboratory.

Note: The test site complies with ANSI C63.4 2014 requirement.

FCC Designation No.: TW1190 and TW3786

1.5 Applicable Standards

According to the specifications of the manufacturer, the EUT must comply with the requirements of the following standards:

- ♦ ANSI C63.26-2015
- ♦ ANSI / TIA-603-E
- ♦ FCC 47 CFR Part 2, 27
- ♦ FCC KDB 971168 D01 Power Meas. License Digital Systems v03r01
- ♦ FCC KDB 412172 D01 Determining ERP and EIRP v01r01
- ♦ FCC KDB 414788 D01 Radiated Test Site v01r01
- ♦ FCC KDB 662911 D01 Multiple Transmitter Output v02r01.

Remark:

1. All test items were verified and recorded according to the standards and without any deviation during the test.
2. This EUT has also been tested and complied with the requirements of FCC Part 15, Subpart B, recorded in a separate test report.
3. The TAF code is not including all the FCC KDB listed without accreditation..



2 Test Configuration of Equipment Under Test

2.1 Test Mode

Antenna port conducted and radiated test items listed below are performed according to KDB 971168 D01 Power Meas. License Digital Systems v03r01 with maximum output power.

For radiated measurement, the measured emission level of the EUT was maximized by rotating the EUT on a turntable, adjusting the orientation of the EUT (open and close) and EUT antenna in three orthogonal axis (X: flat, Y: portrait, Z: landscape) and accessory (Adapter or Earphone), and adjusting the measurement antenna orientation, following C63.26 exploratory test procedures and only the worst case emissions were reported in this report.

Test Items	NR Band	Bandwidth (MHz)												Modulation					RB #			Test Channel				
		10	15	20	25	30	40	50	60	70	80	90	100	PI/2 BPSK	QPSK	16QAM	64QAM	256QAM	1	Half	Full	L	M	H		
Max. Output Power	n77	v	v	v	v	v	v	v	v	v	v	v	v	v	v	v	v	v	v	v	v	v	v	v	v	v
Peak-to-Average Ratio	n77			v										v	v	v	v	v			v				v	
26dB and 99% Bandwidth	n77	v	v	v	v	v	v	v	v	v	v	v	v	v	v	v	v	v			v				v	
Conducted Band Edge	n77	v	v	v	v	v	v	v	v	v	v	v	v	v	v	v	v	v	v		v	v				v
Conducted Spurious Emission	n77	v																		v				v	v	v
Frequency Stability	n77			v										v										v		v
E.I.R.P	n77	v	v	v	v	v	v	v	v	v	v	v	v	v	v	v	v	v	Max. Power							
Radiated Spurious Emission	n77	Worst Case																						v	v	v

Remark

- The mark "v" means that this configuration is chosen for testing
- The mark "-" means that this bandwidth is not supported.
- The device is investigated from 30MHz to 10 times of fundamental signal for radiated spurious emission test under different RB size/offset and modulations in exploratory test. Subsequently, only the worst case emissions are reported.
- For radiated measurement, pre-scanned in two modes, DFT-s OFDM and CP OFDM. The worst cases (DFT-s OFDM) were recorded in this report, and the worst modes of FR1 and LTE for simultaneous transmission were verified and compliant.
- For 5G NR test combination is EN-DC 66A-n77A.
- All the radiated test cases were performed with Adapter 2 and USB Cable 1
- One representative bandwidth is selected to perform PAR and frequency stability.
- During the preliminary test, both charging modes (Adapter mode and WPT client mode) were verified. It is determined that the adaptor mode is the worst case for official test.
- The n77 supports total 4 UL MIMO combinations: Ant6+Ant1, Ant6+Ant5, Ant2+Ant1, Ant2+Ant5 and the worst case combination is determined during the preliminary test that Ant6+Ant1 is reported as worst case with Ant2+Ant5 RSE check data.

2.2 Connection Diagram of Test System

<EUT with Adapter>

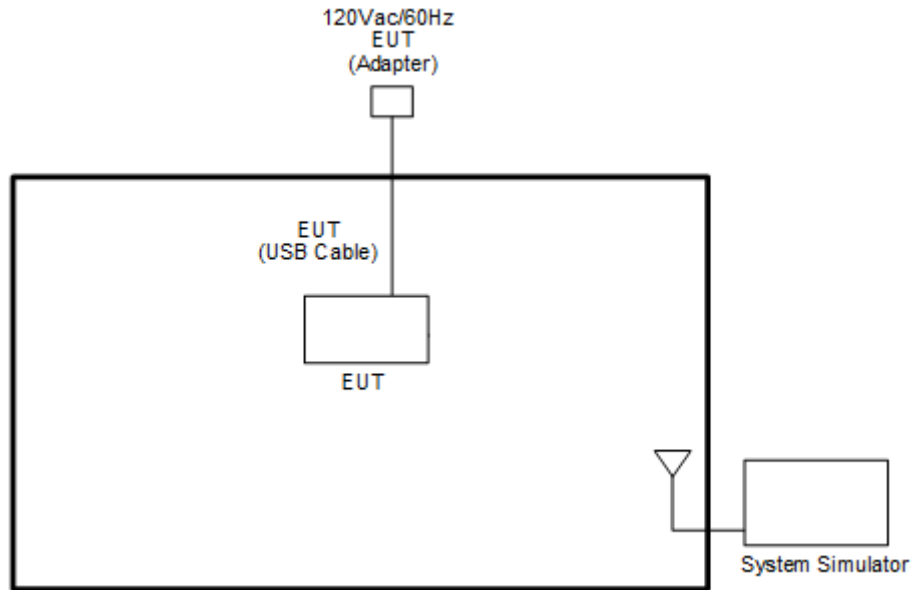

<EUT without Accessory>

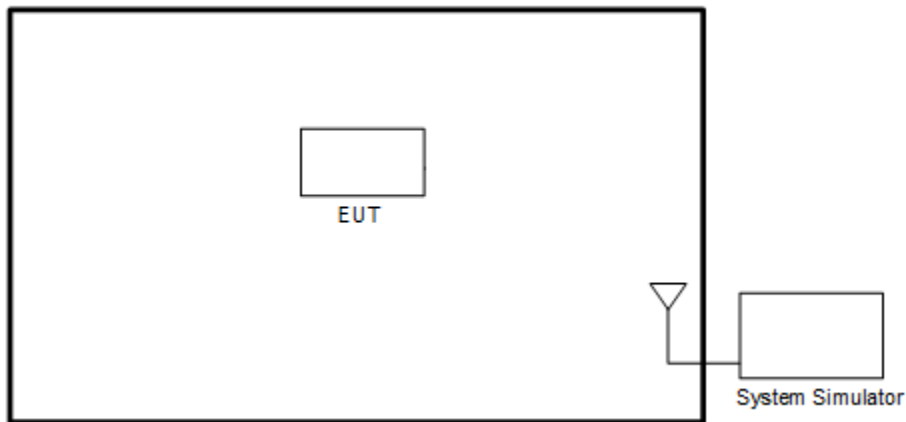

2.3 Support Unit used in test configuration and system

Item	Equipment	Brand Name	Model No.	FCC ID	Data Cable	Power Cord
1.	5G Wireless Test Platform	Anritsu	MT8000A	N/A	N/A	Unshielded, 1.8 m
2.	System Simulator	Anritsu	MT8821C	N/A	N/A	Unshielded, 1.8 m



2.4 Measurement Results Explanation Example

For all conducted test items:

The offset level is set in the spectrum analyzer to compensate the RF cable loss and attenuator factor between EUT conducted output port and spectrum analyzer. With the offset compensation, the spectrum analyzer reading level is exactly the EUT RF output level.

The spectrum analyzer offset is derived from RF cable loss and attenuator factor.

Offset = RF cable loss + attenuator factor.

Following shows an offset computation example with cable loss 4.2 dB and 10dB attenuator.

Example :

$$\begin{aligned} \text{Offset(dB)} &= \text{RF cable loss(dB)} + \text{attenuator factor(dB)}. \\ &= 4.2 + 10 = 14.2 \text{ (dB)} \end{aligned}$$



2.5 Frequency List of Low/Middle/High Channels

5G NR Band n77 Channel and Frequency List				
BW [MHz]	Channel/Frequency(MHz)	Lowest	Middle	Highest
100	Channel	650000	656000	662000
	Frequency	3750	3840	3930
90	Channel	649668	656000	662332
	Frequency	3745.02	3840	3934.98
80	Channel	649334	656000	662666
	Frequency	3740.01	3840	3939.99
70	Channel	649000	656000	663000
	Frequency	3735	3840	3945
60	Channel	648668	656000	663332
	Frequency	3730.02	3840	3949.98
50	Channel	648334	656000	663666
	Frequency	3725.01	3840	3954.99
40	Channel	648000	656000	664000
	Frequency	3720	3840	3960
30	Channel	647668	656000	664332
	Frequency	3715.02	3840	3965
20	Channel	647334	656000	664666
	Frequency	3710.01	3840	3969.99
25	Channel	647500	656000	664500
	Frequency	3712.5	3840	3967.5
15	Channel	647168	656000	664832
	Frequency	3707.52	3840	3972.48
10	Channel	647000	656000	665000
	Frequency	3705	3840	3975

3 Conducted Test Items

3.1 Measuring Instruments

See list of measuring instruments of this test report.

3.1.1 Test Setup

3.1.2 Conducted Output Power

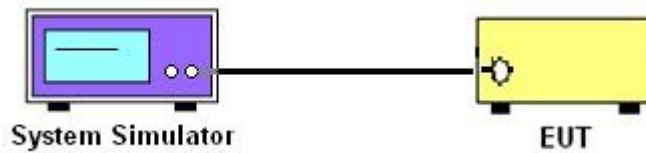

3.1.3 Peak-to-Average Ratio, Occupied Bandwidth ,Conducted Band-Edge and Conducted Spurious Emission

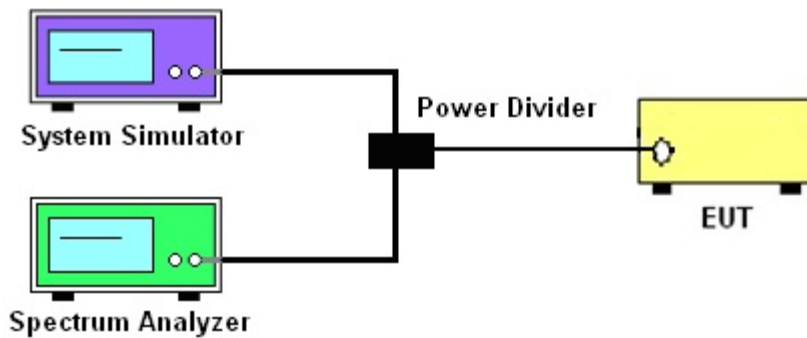

3.1.4 Frequency Stability

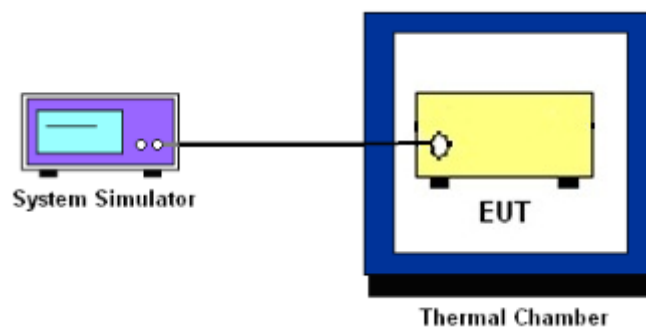

3.1.5 Test Result of Conducted Test

Please refer to Appendix A.



3.2 Conducted Output Power and EIRP

3.2.1 Description of the Conducted Output Power Measurement and EIRP Measurement

A system simulator was used to establish communication with the EUT. Its parameters were set to force the EUT transmitting at maximum output power. The measured power in the radio frequency on the transmitter output terminals shall be reported.

The EIRP of mobile transmitters must not exceed 1 Watts for 5G NR n77

According to KDB 412172 D01 Power Approach,

$EIRP = P_T + G_T - L_C$, where

P_T = transmitter output power in dBm

G_T = gain of the transmitting antenna in dBi

L_C = signal attenuation in the connecting cable between the transmitter and antenna in dB

3.2.2 Test Procedures

1. The transmitter output port was connected to the system simulator.
2. Set EUT at maximum power through the system simulator.
3. Select lowest, middle, and highest channels for each band and different modulation.
4. Measure and record the power level from the system simulator.
5. The MIMO mode is completely uncorrelated, so the directional gain is selected the maximum gain among all antennas.



3.3 Peak-to-Average Ratio

3.3.1 Description of the PAR Measurement

Power Complementary Cumulative Distribution Function (CCDF) curves provide a means for characterizing the power peaks of a digitally modulated signal on a statistical basis. A CCDF curve depicts the probability of the peak signal amplitude exceeding the average power level. Most contemporary measurement instrumentation include the capability to produce CCDF curves for an input signal provided that the instrument's resolution bandwidth can be set wide enough to accommodate the entire input signal bandwidth. In measuring transmissions in this band using an average power technique, the peak-to-average ratio (PAR) of the transmission may not exceed 13 dB.

3.3.2 Test Procedures

The testing follows ANSI C63.26-2015 Section 5.2.6

1. The EUT was connected to spectrum and system simulator via a power divider.
2. Set the CCDF (Complementary Cumulative Distribution Function) option in spectrum analyzer.
3. The highest RF powers were measured and recorded the maximum PAPR level associated with a probability of 0.1 %.
4. Record the deviation as Peak to Average Ratio.



3.4 Occupied Bandwidth

3.4.1 Description of Occupied Bandwidth Measurement

The occupied bandwidth is the width of a frequency band such that, below the lower and above the upper frequency limits, the mean powers emitted are each equal to a specified percentage 0.5% of the total mean transmitted power.

The 26 dB emission bandwidth is defined as the frequency range between two points, one above and one below the carrier frequency, at which the spectral density of the emission is attenuated 26 dB below the maximum in-band spectral density of the modulated signal. Spectral density (power per unit bandwidth) is to be measured with a detector of resolution bandwidth equal to approximately 1.0% of the emission bandwidth.

3.4.2 Test Procedures

The testing follows ANSI C63.26-2015 Section 5.4.3 (26dB) and Section 5.4.4 (99OB)

1. The EUT was connected to spectrum analyzer and system simulator via a power divider.
2. The spectrum analyzer center frequency is set to the nominal EUT channel center frequency. The span range for the spectrum analyzer shall be between two and five times the anticipated OBW.
3. The nominal resolution bandwidth (RBW) shall be in the range of 1 to 5 % of the anticipated OBW, and the VBW shall be at least 3 times the RBW.
4. Set the detection mode to peak, and the trace mode to max hold.
5. Determine the reference value: Set the EUT to transmit a modulated signal. Allow the trace to stabilize. Set the spectrum analyzer marker to the highest level of the displayed trace.
(this is the reference value)
6. Determine the “-26 dB down amplitude” as equal to (Reference Value – X).
7. Place two markers, one at the lowest and the other at the highest frequency of the envelope of the spectral display such that each marker is at or slightly below the “-X dB down amplitude” determined in step 6. If a marker is below this “-X dB down amplitude” value it shall be placed as close as possible to this value. The OBW is the positive frequency difference between the two markers.
8. Use the 99 % power bandwidth function of the spectrum analyzer and report the measured bandwidth.



3.5 Conducted Band Edge

3.5.1 Description of Conducted Band Edge Measurement

27.53 (l)(2)

For mobile operations in the 3700-3980 MHz band, the conducted power of any emission outside the licensee's authorized bandwidth shall not exceed -13 dBm/MHz. Compliance with this paragraph (l)(2) is based on the use of measurement instrumentation employing a resolution bandwidth of 1 megahertz or greater. However, in the 1 megahertz bands immediately outside and adjacent to the licensee's frequency block, the minimum resolution bandwidth for the measurement shall be either one percent of the emission bandwidth of the fundamental emission of the transmitter or 350 kHz. In the bands between 1 and 5 MHz removed from the licensee's frequency block, the minimum resolution bandwidth for the measurement shall be 500 kHz. The emission bandwidth is defined as the width of the signal between two points, one below the carrier center frequency and one above the carrier center frequency, outside of which all emissions are attenuated at least 26 dB below the transmitter power.

3.5.2 Test Procedures

The testing follows FCC KDB 971168 D01 v03r01 Section 6.1.

1. The EUT was connected to spectrum analyzer and system simulator via a power divider.
2. The band edges of low and high channels for the highest RF powers were measured.
3. Set RBW \geq 1% EBW in the 1MHz band immediately outside and adjacent to the band edge.
4. Beyond the 1 MHz band from the band edge, RBW=1MHz was used.
5. Set spectrum analyzer with RMS detector.
6. The RF fundamental frequency should be excluded against the limit line in the operating frequency band.
7. Checked that all the results comply with the emission limit line.

The limit line is derived from $43 + 10\log(P)$ dB below the transmitter power P(Watts)



3.6 Conducted Spurious Emission

3.6.1 Description of Conducted Spurious Emission Measurement

The power of any emission outside of the authorized operating frequency ranges must be lower than the transmitter power (P) by a factor of at least $43 + 10 \log (P)$ dB.

3.6.2 Test Procedures

The testing follows FCC KDB 971168 D01 v03r01 Section 6.1.

1. The EUT was connected to spectrum analyzer and system simulator via a power divider.
2. The RF output of EUT was connected to the spectrum analyzer by RF cable and attenuator. The path loss was compensated to the results for each measurement.
3. The middle channel for the highest RF power within the transmitting frequency was measured.
4. The conducted spurious emission for the whole frequency range was taken.
5. Make the measurement with the spectrum analyzer's RBW = 1MHz, VBW = 3MHz.
6. Set spectrum analyzer with RMS detector.
7. Taking the record of maximum spurious emission.
8. The RF fundamental frequency should be excluded against the limit line in the operating frequency band.
9. The limit line is derived from $43 + 10\log(P)$ dB below the transmitter power P(Watts)



3.7 Frequency Stability

3.7.1 Description of Frequency Stability Measurement

27.54

The frequency stability shall be sufficient to ensure that the fundamental emission stays within the authorized frequency block.

3.7.2 Test Procedures for Temperature Variation

The testing follows FCC KDB 971168 D01 v03r01 Section 9.0.

1. The EUT was set up in the thermal chamber and connected with the system simulator.
2. With power OFF, the temperature was decreased to -30°C and the EUT was stabilized before testing. Power was applied and the maximum change in frequency was recorded within one minute.
3. With power OFF, the temperature was raised in 10°C step up to 50°C . The EUT was stabilized at each step for at least half an hour. Power was applied and the maximum frequency change was recorded within one minute.

3.7.3 Test Procedures for Voltage Variation

The testing follows FCC KDB 971168 D01 v03r01 Section 9.0.

1. The EUT was placed in a temperature chamber at $20\pm 5^{\circ}\text{C}$ and connected with the system simulator.
2. The power supply voltage to the EUT was varied from 85% to 115% of the nominal value measured at the input to the EUT.
3. The variation in frequency was measured for the worst case.

4 Radiated Test Items

4.1 Measuring Instruments

See list of measuring instruments of this test report.

4.1.1 Test Setup

For radiated emissions below 30MHz

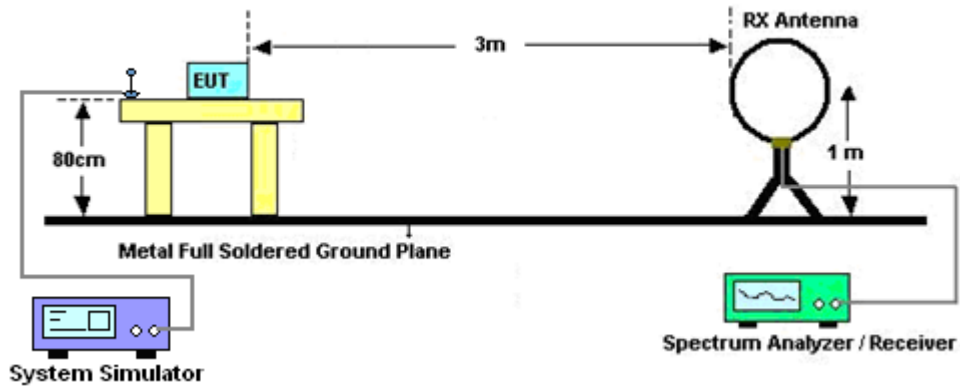

For radiated test from 30MHz to 1GHz

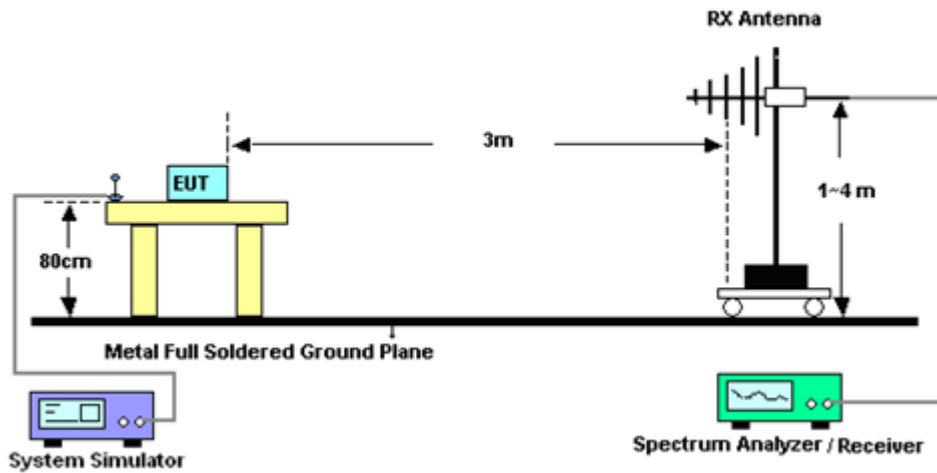

For radiated test from 1GHz to 18GHz

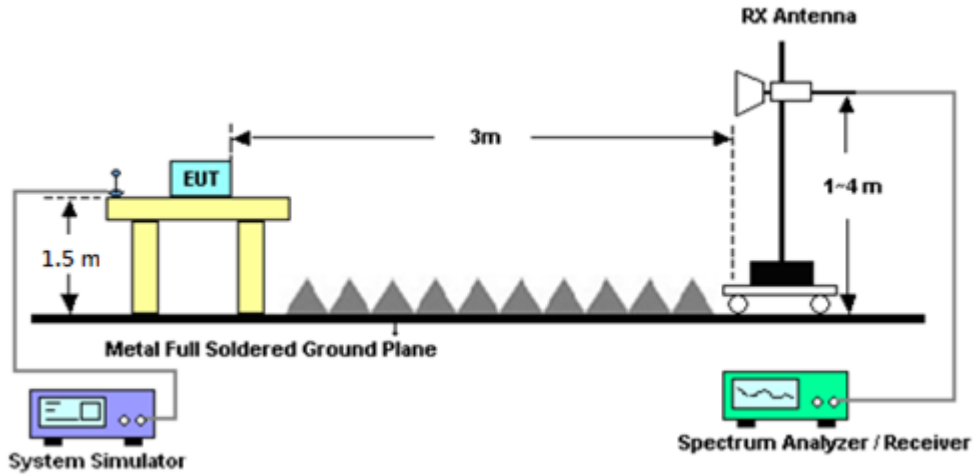

For radiated test above 18GHz

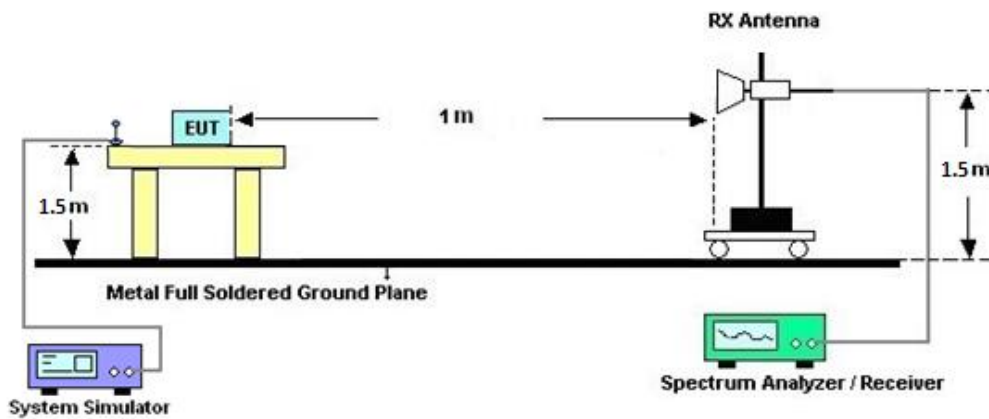

4.1.2 Test Result of Radiated Test

Please refer to Appendix B.

Note:

The low frequency, which started from 9 kHz to 30MHz, was pre-scanned and the result which was 20dB lower than the limit line was not reported.

There is adequate comparison measurement of both open-field test site and alternative test site - semi-Anechoic chamber according to 414788 D01 Radiated Test Site v01r01, and the result came out very similar.



4.2 Radiated Spurious Emission Measurement

4.2.1 Description of Radiated Spurious Emission Measurement

The radiated spurious emission was measured by substitution method according to ANSI / TIA-603-E. The power of any emission outside of the authorized operating frequency ranges must be attenuated below the transmitter power (P) by a factor of at least $43 + 10 \log (P)$ dB.

4.2.2 Test Procedures

The testing follows FCC KDB 971168 D01 v03r01 Section 7 and ANSI / TIA-603-E Section 2.2.12.

1. The EUT was placed on a turntable with 0.8 meter for frequency below 1GHz and 1.5 meter for frequency above 1GHz respectively above ground.
2. The EUT was set 3 meters from the receiving antenna, which was mounted on the antenna tower.
3. The table was rotated 360 degrees to determine the position of the highest spurious emission.
4. The height of the receiving antenna is varied between one meter and four meters to search the maximum spurious emission for both horizontal and vertical polarizations.
5. Make the measurement with the spectrum analyzer's RBW = 1MHz, VBW = 3MHz, taking the record of maximum spurious emission.
6. A horn antenna was substituted in place of the EUT and was driven by a signal generator.
7. Tune the output power of signal generator to the same emission level with EUT maximum spurious emission.
8. Taking the record of output power at antenna port.
9. Repeat step 7 to step 8 for another polarization.
10. The RF fundamental frequency should be excluded against the limit line in the operating frequency band.

The limit line is derived from $43 + 10\log(P)$ dB below the transmitter power P(Watts)



5 List of Measuring Equipment

Instrument	Brand Name	Model No.	Serial No.	Characteristics	Calibration Date	Test Date	Due Date	Remark
Loop Antenna	Rohde & Schwarz	HFH2-Z2	100488	9 kHz~30 MHz	Sep. 20, 2022	Dec. 05, 2022~ Jan. 09, 2023	Sep. 19, 2023	Radiation (03CH12-HY)
Horn Antenna	SCHWARZBECK	BBHA 9120 D	9120D-02114	1GHz~18GHz	Aug. 09, 2022	Dec. 05, 2022~ Jan. 09, 2023	Aug. 08, 2023	Radiation (03CH12-HY)
Bilog Antenna	TESEQ	CBL 6111D & 00800N1D01N-06	40103 & 07	30MHz~1GHz	Apr. 24, 2022	Dec. 05, 2022~ Jan. 09, 2023	Apr. 23, 2023	Radiation (03CH12-HY)
Bilog Antenna	TESEQ	CBL 6111D & N-6-06	35414 & AT-N0602	30MHz~1GHz	Oct. 08, 2022	Dec. 05, 2022~ Jan. 09, 2023	Oct. 07, 2023	Radiation (03CH12-HY)
Horn Antenna	SCHWARZBECK	BBHA 9120 D	9120D-1212	1GHz~18GHz	Mar. 10, 2022	Dec. 05, 2022~ Jan. 09, 2023	Mar. 09, 2023	Radiation (03CH12-HY)
SHF-EHF Horn Antenna	SCHWARZBECK	BBHA 9170	BBHA9170251	18GHz~40GHz	Nov. 24, 2022	Dec. 05, 2022~ Jan. 09, 2023	Nov. 23, 2023	Radiation (03CH12-HY)
SHF-EHF Horn Antenna	SCHWARZBECK	BBHA 9170	BBHA9170576	18GHz~40GHz	May 14, 2022	Dec. 05, 2022~ Jan. 09, 2023	May 13, 2023	Radiation (03CH12-HY)
Preamplifier	COM-POWER	PA-103	161075	10MHz~1GHz	Mar. 23, 2022	Dec. 05, 2022~ Jan. 09, 2023	Mar. 22, 2023	Radiation (03CH12-HY)
Preamplifier	Aglient	8449B	3008A02375	1GHz~26.5GHz	May 24, 2022	Dec. 05, 2022~ Jan. 09, 2023	May 23, 2023	Radiation (03CH12-HY)
Preamplifier	E-INSTRUMENT TECH LTD.	ERA-100M-18G-5 6-01-A70	EC1900249	1GHz-18GHz	Dec. 22, 2021	Dec. 05, 2022~ Dec. 20, 2022	Dec. 21, 2022	Radiation (03CH12-HY)
Preamplifier	E-INSTRUMENT TECH LTD.	ERA-100M-18G-5 6-01-A70	EC1900249	1GHz-18GHz	Dec. 21, 2022	Dec. 21, 2022~ Jan. 09, 2023	Dec. 20, 2023	Radiation (03CH12-HY)
Preamplifier	EMEC	EM18G40G	060715	18GHz~40GHz	Dec. 07, 2022	Dec. 07, 2022~ Jan. 09, 2023	Dec. 06, 2023	Radiation (03CH12-HY)
Spectrum Analyzer	Keysight	N9010A	MY53470118	10Hz~44GHz	Jan. 12, 2022	Dec. 05, 2022~ Jan. 09, 2023	Jan. 11, 2023	Radiation (03CH12-HY)
RF Cable	HUBER + SUHNER	SUCOFLEX 104	MY9837/4PE	9kHz~30MHz	Mar. 10, 2022	Dec. 05, 2022~ Jan. 09, 2023	Mar. 09, 2023	Radiation (03CH12-HY)
RF Cable	HUBER + SUHNER	SUCOFLEX 104	MY15539/4	30MHz~18GHz	Mar. 15, 2022	Dec. 05, 2022~ Dec. 19, 2022	Mar. 14, 2023	Radiation (03CH12-HY)
RF Cable	HUBER + SUHNER	SUCOFLEX 104	MY15539/4	30MHz~18GHz	Dec. 20, 2022	Dec. 20, 2022~ Jan. 09, 2023	Dec. 19, 2023	Radiation (03CH12-HY)
RF Cable	HUBER + SUHNER	SUCOFLEX 104	MY9837/4PE	30MHz~18GHz	Mar. 10, 2022	Dec. 05, 2022~ Dec. 19, 2022	Mar. 09, 2023	Radiation (03CH12-HY)
RF Cable	HUBER + SUHNER	SUCOFLEX 126E	0058/126E	30MHz~18GHz	Dec. 20, 2022	Dec. 20, 2022~ Jan. 09, 2023	Dec. 19, 2023	Radiation (03CH12-HY)
RF Cable	HUBER + SUHNER	SUCOFLEX 102	505134/2	30MHz~40GHz	Feb. 21, 2022	Dec. 05, 2022~ Dec. 19, 2022	Feb. 20, 2023	Radiation (03CH12-HY)
RF Cable	HUBER + SUHNER	SUCOFLEX 102	505134/2	30MHz~40GHz	Dec. 20, 2022	Dec. 20, 2022~ Jan. 09, 2023	Dec. 19, 2023	Radiation (03CH12-HY)
RF Cable	HUBER + SUHNER	SUCOFLEX 102	803953/2	30MHz~40GHz	Mar. 08, 2022	Dec. 05, 2022~ Dec. 19, 2023	Mar. 07, 2023	Radiation (03CH12-HY)
RF Cable	HUBER + SUHNER	SUCOFLEX 102	803953/2	30MHz~40GHz	Dec. 20, 2022	Dec. 20, 2022~ Jan. 09, 2023	Dec. 19, 2023	Radiation (03CH12-HY)
Filter	Wainwright	WHKX8-5872.5-6 750-18000-40ST	SN2	6.75GHz High Pass Filter	Mar. 15, 2022	Dec. 05, 2022~ Jan. 09, 2023	Mar. 14, 2023	Radiation (03CH12-HY)
Filter	Wainwright	WHKX12-2700-30 00-18000-60ST	SN2	3GHz High Pass Filter	Jul. 11, 2022	Dec. 05, 2022~ Jan. 09, 2023	Jul. 10, 2023	Radiation (03CH12-HY)
Filter	Wainwright	WHKX12-1080-12 00-15000-60SS	SN1	1.2GHz High Pass Filter	Mar. 15, 2022	Dec. 05, 2022~ Jan. 09, 2023	Mar. 14, 2023	Radiation (03CH12-HY)
Hygrometer	TECPEL	DTM-303B	TP140325	N/A	Nov. 07, 2022	Dec. 05, 2022~ Jan. 09, 2023	Nov. 06, 2023	Radiation (03CH12-HY)
Controller	EMEC	EM1000	N/A	Control Turn table & Ant Mast	N/A	Dec. 05, 2022~ Jan. 09, 2023	N/A	Radiation (03CH12-HY)
Antenna Mast	EMEC	AM-BS-4500-B	N/A	1m~4m	N/A	Dec. 05, 2022~ Jan. 09, 2023	N/A	Radiation (03CH12-HY)
Turn Table	EMEC	TT2000	N/A	0~360 Degree	N/A	Dec. 05, 2022~ Jan. 09, 2023	N/A	Radiation (03CH12-HY)



Instrument	Brand Name	Model No.	Serial No.	Characteristics	Calibration Date	Test Date	Due Date	Remark
Software	Audix	E3 6.2009-8-24	RK-000989	N/A	N/A	Dec. 05, 2022~ Jan. 09, 2023	N/A	Radiation (03CH12-HY)
Programmable Power Supply	GW Instek	PSS-2005	EL890001	0V~64V ;0A~6A	Sep. 29, 2022	Nov. 23, 2022~ Jan. 18, 2023	Sep. 28, 2023	Conducted (TH03-HY)
Hygrometer	Testo	608-H11	34893241	NA	Mar. 18, 2022	Nov. 23, 2022~ Jan. 18, 2023	Mar. 17, 2023	Conducted (TH03-HY)
Signal Analyzer	Rohde & Schwarz	FSV3044	101048	10Hz~44GHz	May 05, 2022	Nov. 23, 2022~ Jan. 18, 2023	May 04, 2023	Conducted (TH03-HY)
Temperature Chamber	ESPEC	SH-641	92013720	-40°C ~90°C	Sep. 07, 2022	Nov. 23, 2022~ Jan. 18, 2023	Sep. 06, 2023	Conducted (TH03-HY)
Base Station (Measure)	Anritsu	MT8821C	6262116730	LTE	Jun. 15, 2022	Nov. 23, 2022~ Jan. 18, 2023	Jun. 14, 2023	Conducted (TH03-HY)
Base Station (Measure)	Anritsu	MT8000A	6262134933	FR1	Jun. 13, 2022	Nov. 23, 2022~ Jan. 18, 2023	Jun. 22, 2023	Conducted (TH03-HY)



6 Uncertainty of Evaluation

Uncertainty of Radiated Emission Measurement (30 MHz ~ 1000 MHz)

Measuring Uncertainty for a Level of Confidence of 95% ($U = 2Uc(y)$)	3.31 dB
---	---------

Uncertainty of Radiated Emission Measurement (1 GHz ~ 18 GHz)

Measuring Uncertainty for a Level of Confidence of 95% ($U = 2Uc(y)$)	3.25 dB
---	---------

Uncertainty of Radiated Emission Measurement (18 GHz ~ 40 GHz)

Measuring Uncertainty for a Level of Confidence of 95% ($U = 2Uc(y)$)	3.81 dB
---	---------



Appendix A. Test Results of Conducted Test

Conducted Output Power(Average power) and EIRP

<Primary Antenna>

NR n77 Maximum Average Power [dBm] (GT - LC = -2.8 dB)								
BW [MHz]	RB Size	RB Offset	Mod	Lowest	Middle	Highest	EIRP (dBm)	EIRP(W)
10	1	1	PI/2 BPSK	24.16	24.16	23.63	21.38	0.1374
10	1	22		24.06	24.02	23.57		
10	12	6		24.11	24.00	23.61		
10	1	0		23.68	23.65	23.11		
10	1	23		23.55	23.52	23.07		
10	24	0		23.60	23.44	23.10		
10	1	1	QPSK	24.18	24.16	23.69		
10	1	22		24.05	23.96	23.58		
10	12	6		24.09	24.01	23.64		
10	1	0		23.22	23.15	22.63		
10	1	23		23.04	22.98	22.62		
10	24	0		23.11	23.01	22.60		
10	1	1	16-QAM	23.11	23.06	22.73	20.31	0.1074
10	1	1	64-QAM	21.68	21.62	21.11		
10	1	1	256-QAM	19.71	19.60	18.86		
Limit	EIRP < 1W			Result			Pass	

NR n77 Maximum Average Power [dBm] (GT - LC = -2.8 dB)								
BW [MHz]	RB Size	RB Offset	Mod	Lowest	Middle	Highest	EIRP (dBm)	EIRP(W)
15	1	1	PI/2 BPSK	24.02	23.34	23.39	21.31	0.1352
15	1	36		23.91	23.13	23.53		
15	18	9		23.98	23.32	23.45		
15	1	0		23.58	22.87	22.95		
15	1	37		23.55	22.66	22.96		
15	36	0		23.48	22.85	22.98		
15	1	1	QPSK	24.11	23.36	23.39		
15	1	36		23.94	23.18	23.48		
15	18	9		23.99	23.32	23.45		
15	1	0		23.12	22.42	22.42		
15	1	37		23.04	22.15	22.46		
15	36	0		22.97	22.32	22.46		
15	1	1	16-QAM	23.24	23.14	22.40	20.44	0.1107
15	1	1	64-QAM	21.42	21.55	20.93		
15	1	1	256-QAM	19.55	19.59	18.75		
Limit	EIRP < 1W			Result			Pass	



NR n77 Maximum Average Power [dBm] (GT - LC = -2.8 dB)								
BW [MHz]	RB Size	RB Offset	Mod	Lowest	Middle	Highest	EIRP (dBm)	EIRP(W)
20	1	1	PI/2 BPSK	24.13	24.07	23.45	21.33	0.1358
20	1	49		24.01	23.89	23.43		
20	25	12		23.93	24.08	23.45		
20	1	0		23.64	23.62	22.96		
20	1	50		23.50	23.56	22.92		
20	50	0		23.60	23.56	22.95		
20	1	1	QPSK	24.12	24.11	23.43		
20	1	49		24.00	23.97	23.44		
20	25	12		24.00	24.06	23.47		
20	1	0		23.08	23.17	22.42		
20	1	50		22.98	23.10	22.47		
20	50	0		22.96	23.09	22.44		
20	1	1	16-QAM	23.31	23.18	22.46	20.51	0.1125
20	1	1	64-QAM	21.61	21.61	20.94		
20	1	1	256-QAM	19.43	19.57	18.84		
Limit	EIRP < 1W			Result			Pass	

NR n77 Maximum Average Power [dBm] (GT - LC = -2.8 dB)								
BW [MHz]	RB Size	RB Offset	Mod	Lowest	Middle	Highest	EIRP (dBm)	EIRP(W)
25	1	1	PI/2 BPSK	24.11	24.25	24.16	21.45	0.1396
25	1	63		23.87	24.09	23.89		
25	32	16		24.00	24.11	23.95		
25	1	0		23.68	23.76	23.64		
25	1	64		23.41	23.55	23.37		
25	64	0		23.48	23.61	23.48		
25	1	1	QPSK	24.12	24.25	24.11		
25	1	63		23.88	24.07	23.86		
25	32	16		24.02	24.08	24.01		
25	1	0		23.12	23.24	23.10		
25	1	64		23.85	23.02	22.85		
25	64	0		23.00	23.08	23.01		
25	1	1	16-QAM	23.21	23.32	23.01	20.52	0.1127
25	1	1	64-QAM	21.59	21.76	21.69		
25	1	1	256-QAM	19.68	19.75	19.56		
Limit	EIRP < 1W			Result			Pass	



NR n77 Maximum Average Power [dBm] (GT - LC = -2.8 dB)								
BW [MHz]	RB Size	RB Offset	Mod	Lowest	Middle	Highest	EIRP (dBm)	EIRP(W)
30	1	1	PI/2 BPSK	24.17	24.36	23.54	21.56	0.1432
30	1	76		23.90	24.13	23.43		
30	36	18		24.03	24.15	23.48		
30	1	0		23.70	23.85	23.07		
30	1	77		23.43	23.60	23.01		
30	75	0		23.64	23.64	22.98		
30	1	1	QPSK	24.17	24.34	23.58		
30	1	76		23.92	24.07	23.47		
30	36	18		24.05	24.15	23.50		
30	1	0		23.19	23.36	22.59		
30	1	77		22.88	23.10	22.52		
30	75	0		23.13	23.16	22.46		
30	1	1	16-QAM	23.22	23.33	22.52	20.53	0.1130
30	1	1	64-QAM	21.91	21.52	20.91		
30	1	1	256-QAM	19.72	19.76	19.16		
Limit	EIRP < 1W			Result			Pass	

NR n77 Maximum Average Power [dBm] (GT - LC = -2.8 dB)								
BW [MHz]	RB Size	RB Offset	Mod	Lowest	Middle	Highest	EIRP (dBm)	EIRP(W)
40	1	1	PI/2 BPSK	24.21	24.26	23.52	21.46	0.1400
40	1	104		23.81	23.87	23.47		
40	50	25		24.10	24.13	23.55		
40	1	0		23.65	23.79	23.14		
40	1	105		23.24	23.36	23.05		
40	100	0		23.60	23.65	23.03		
40	1	1	QPSK	24.15	24.23	23.69		
40	1	104		23.75	23.89	23.50		
40	50	25		24.10	24.14	23.47		
40	1	0		23.15	23.20	22.61		
40	1	105		22.70	22.81	22.53		
40	100	0		23.10	23.12	22.50		
40	1	1	16-QAM	23.22	23.51	22.73	20.71	0.1178
40	1	1	64-QAM	21.63	21.75	21.06		
40	1	1	256-QAM	19.60	19.65	18.97		
Limit	EIRP < 1W			Result			Pass	



NR n77 Maximum Average Power [dBm] (GT - LC = -2.8 dB)								
BW [MHz]	RB Size	RB Offset	Mod	Lowest	Middle	Highest	EIRP (dBm)	EIRP(W)
50	1	1	PI/2 BPSK	24.24	24.25	23.72	21.47	0.1403
50	1	131		23.90	23.72	23.54		
50	64	32		24.00	24.15	23.74		
50	1	0		23.74	23.80	23.28		
50	1	132		23.42	23.35	23.02		
50	128	0		23.51	23.61	23.14		
50	1	1	QPSK	24.19	24.27	23.74		
50	1	131		23.89	23.81	23.50		
50	64	32		23.99	24.17	23.64		
50	1	0		23.24	23.18	22.73		
50	1	132		22.99	22.75	22.51		
50	128	0		23.00	23.16	22.64		
50	1	1	16-QAM	23.33	23.53	22.72	20.73	0.1183
50	1	1	64-QAM	21.80	21.74	21.25		
50	1	1	256-QAM	19.63	19.83	19.32		
Limit	EIRP < 1W			Result			Pass	

NR n77 Maximum Average Power [dBm] (GT - LC = -2.8 dB)								
BW [MHz]	RB Size	RB Offset	Mod	Lowest	Middle	Highest	EIRP (dBm)	EIRP(W)
60	1	1	PI/2 BPSK	24.30	24.11	23.78	21.51	0.1416
60	1	160		23.78	23.67	23.60		
60	81	40		24.03	24.12	23.74		
60	1	0		23.82	23.65	23.34		
60	1	161		23.34	23.24	23.12		
60	162	0		23.58	23.55	23.23		
60	1	1	QPSK	24.31	24.15	23.80		
60	1	160		23.73	23.75	23.61		
60	81	40		24.02	24.16	23.75		
60	1	0		23.20	23.14	22.83		
60	1	161		22.78	22.76	22.57		
60	162	0		22.98	23.04	22.78		
60	1	1	16-QAM	23.37	23.28	22.87	20.57	0.1140
60	1	1	64-QAM	21.75	21.77	21.36		
60	1	1	256-QAM	19.64	19.54	19.32		
Limit	EIRP < 1W			Result			Pass	



NR n77 Maximum Average Power [dBm] (GT - LC = -2.8 dB)										
BW [MHz]	RB Size	RB Offset	Mod	Lowest	Middle	Highest	EIRP (dBm)	EIRP(W)		
70	1	1	PI/2 BPSK	24.40	24.20	23.95	21.60	0.1445		
70	1	187		23.92	23.65	23.72				
70	90	45		23.96	24.21	23.84				
70	1	0		23.99	23.67	23.49				
70	1	188		23.43	23.21	23.74				
70	180	0		23.50	23.70	23.35				
70	1	1	QPSK	24.38	24.16	23.97			20.60	0.1148
70	1	187		23.92	23.78	23.67				
70	90	45		23.92	24.24	23.85				
70	1	0		23.37	23.19	22.93				
70	1	188		22.90	22.78	22.69				
70	180	0		22.97	23.19	22.82				
70	1	1	16-QAM	23.40	23.18	22.89	20.60	0.1148		
70	1	1	64-QAM	21.87	21.65	21.41				
70	1	1	256-QAM	19.78	19.50	19.50				
Limit	EIRP < 1W			Result			Pass			

NR n77 Maximum Average Power [dBm] (GT - LC = -2.8 dB)										
BW [MHz]	RB Size	RB Offset	Mod	Lowest	Middle	Highest	EIRP (dBm)	EIRP(W)		
80	1	1	PI/2 BPSK	24.47	24.10	24.20	21.67	0.1469		
80	1	215		23.82	23.71	23.61				
80	108	54		23.98	24.24	23.82				
80	1	0		24.00	23.75	23.67				
80	1	216		23.36	23.27	23.19				
80	216	0		23.50	23.70	23.30				
80	1	1	QPSK	24.45	24.22	24.19			20.72	0.1180
80	1	215		23.82	23.82	23.61				
80	108	54		24.06	24.21	23.82				
80	1	0		23.48	23.19	23.24				
80	1	216		22.82	22.75	22.60				
80	216	0		22.96	23.18	22.78				
80	1	1	16-QAM	23.52	23.21	23.25	20.72	0.1180		
80	1	1	64-QAM	21.98	21.81	21.76				
80	1	1	256-QAM	19.90	19.65	19.56				
Limit	EIRP < 1W			Result			Pass			



NR n77 Maximum Average Power [dBm] (GT - LC = -2.8 dB)										
BW [MHz]	RB Size	RB Offset	Mod	Lowest	Middle	Highest	EIRP (dBm)	EIRP(W)		
90	1	1	PI/2 BPSK	24.51	24.07	24.07	21.72	0.1486		
90	1	243		23.86	23.83	23.65				
90	120	60		24.15	24.25	23.85				
90	1	0		24.06	23.61	23.68				
90	1	244		23.40	23.32	23.14				
90	243	0		23.66	23.73	23.37				
90	1	1	QPSK	24.52	24.15	24.05			21.01	0.1262
90	1	243		23.88	23.76	23.65				
90	120	60		24.16	24.25	23.91				
90	1	0		23.52	23.18	23.06				
90	1	244		22.97	22.81	22.60				
90	243	0		23.17	23.21	22.85				
90	1	1	16-QAM	23.81	23.15	23.05	21.01	0.1262		
90	1	1	64-QAM	22.23	21.74	21.50				
90	1	1	256-QAM	20.02	19.80	19.51				
Limit	EIRP < 1W			Result			Pass			

NR n77 Maximum Average Power [dBm] (GT - LC = -2.8 dB)										
BW [MHz]	RB Size	RB Offset	Mod	Lowest	Middle	Highest	EIRP (dBm)	EIRP(W)		
100	1	1	PI/2 BPSK	24.23	23.76	23.74	21.71	0.1483		
100	1	271		24.51	24.21	24.15				
100	135	67		24.16	24.23	23.88				
100	1	0		23.76	23.33	23.30				
100	1	272		24.07	23.79	23.71				
100	270	0		23.70	23.70	23.38				
100	1	1	QPSK	24.22	23.81	23.76			20.68	0.1169
100	1	271		24.49	24.25	24.14				
100	135	67		24.18	24.25	23.84				
100	1	0		23.24	22.79	22.82				
100	1	272		23.53	23.24	23.13				
100	270	0		23.17	23.27	22.84				
100	1	1	16-QAM	23.48	22.82	22.75	20.68	0.1169		
100	1	1	64-QAM	22.06	21.28	21.23				
100	1	1	256-QAM	19.71	19.25	19.24				
Limit	EIRP < 1W			Result			Pass			



NR n77 HPUE Maximum Average Power [dBm] (GT - LC = -2.8 dB)								
BW [MHz]	RB Size	RB Offset	Mod	Lowest	Middle	Highest	EIRP (dBm)	EIRP(W)
10	1	1	PI/2 BPSK	25.78	25.83	25.28	23.05	0.2018
10	1	22		25.66	25.65	25.21		
10	12	6		25.72	25.74	25.27		
10	1	0		24.29	24.31	23.70		
10	1	23		24.14	24.11	23.65		
10	24	0		25.18	25.19	24.76		
10	1	1	QPSK	25.74	25.85	25.26		
10	1	22		25.74	25.66	25.24		
10	12	6		25.68	25.70	25.25		
10	1	0		24.23	24.41	23.71		
10	1	23		24.19	24.18	23.65		
10	24	0		24.68	24.68	24.30		
10	1	1	16-QAM	24.80	24.97	24.28	22.17	0.1648
10	1	1	64-QAM	23.11	23.15	22.91		
10	1	1	256-QAM	21.32	21.30	20.64		
Limit	EIRP < 1W			Result			Pass	

NR n77 HPUE Maximum Average Power [dBm] (GT - LC = -2.8 dB)								
BW [MHz]	RB Size	RB Offset	Mod	Lowest	Middle	Highest	EIRP (dBm)	EIRP(W)
15	1	1	PI/2 BPSK	25.82	25.91	25.29	23.11	0.2046
15	1	36		25.68	25.65	25.30		
15	18	9		25.74	25.80	25.31		
15	1	0		24.36	24.44	23.76		
15	1	37		24.40	24.17	23.71		
15	36	0		25.22	25.35	24.81		
15	1	1	QPSK	25.81	25.90	25.32		
15	1	36		25.72	25.67	25.31		
15	18	9		25.73	25.87	25.32		
15	1	0		24.33	24.41	23.79		
15	1	37		24.29	24.18	23.74		
15	36	0		24.73	24.86	24.30		
15	1	1	16-QAM	25.19	24.92	24.35	22.39	0.1734
15	1	1	64-QAM	23.40	23.51	22.69		
15	1	1	256-QAM	21.36	21.35	20.73		
Limit	EIRP < 1W			Result			Pass	



NR n77 HPUE Maximum Average Power [dBm] (GT - LC = -2.8 dB)								
BW [MHz]	RB Size	RB Offset	Mod	Lowest	Middle	Highest	EIRP (dBm)	EIRP(W)
20	1	1	PI/2 BPSK	25.97	26.03	25.27	23.23	0.2104
20	1	49		25.97	25.75	25.32		
20	25	12		25.90	25.89	25.31		
20	1	0		24.48	24.55	23.77		
20	1	50		24.39	24.34	23.77		
20	50	0		25.36	25.40	24.84		
20	1	1	QPSK	26.01	26.00	25.36		
20	1	49		25.98	25.70	25.34		
20	25	12		25.86	25.97	25.40		
20	1	0		24.46	24.54	23.84		
20	1	50		24.38	24.34	23.85		
20	50	0		24.87	24.91	24.48		
20	1	1	16-QAM	24.94	24.91	24.26	22.14	0.1637
20	1	1	64-QAM	23.74	23.30	22.78		
20	1	1	256-QAM	21.53	21.24	20.68		
Limit	EIRP < 1W			Result			Pass	

NR n77 HPUE Maximum Average Power [dBm] (GT - LC = -2.8 dB)								
BW [MHz]	RB Size	RB Offset	Mod	Lowest	Middle	Highest	EIRP (dBm)	EIRP(W)
25	1	1	PI/2 BPSK	25.98	26.13	25.46	23.33	0.2153
25	1	63		25.84	25.78	25.37		
25	32	16		25.89	25.88	25.34		
25	1	0		24.51	24.62	23.89		
25	1	64		24.30	24.27	23.79		
25	64	0		25.40	25.37	24.80		
25	1	1	QPSK	26.03	26.08	25.44		
25	1	63		25.85	25.76	25.29		
25	32	16		25.90	25.87	25.35		
25	1	0		24.47	24.62	23.90		
25	1	64		24.32	24.24	23.80		
25	64	0		24.90	24.82	24.28		
25	1	1	16-QAM	25.10	25.15	24.90	22.35	0.1718
25	1	1	64-QAM	23.73	23.88	22.88		
25	1	1	256-QAM	21.46	21.59	20.77		
Limit	EIRP < 1W			Result			Pass	



NR n77 HPUE Maximum Average Power [dBm] (GT - LC = -2.8 dB)								
BW [MHz]	RB Size	RB Offset	Mod	Lowest	Middle	Highest	EIRP (dBm)	EIRP(W)
30	1	1	PI/2 BPSK	25.92	26.17	25.51	23.38	0.2178
30	1	76		25.72	25.81	25.46		
30	36	18		25.82	25.89	25.43		
30	1	0		24.44	24.70	24.03		
30	1	77		24.26	24.30	23.98		
30	75	0		25.45	25.40	24.93		
30	1	1	QPSK	25.97	26.18	25.52		
30	1	76		25.77	25.80	25.43		
30	36	18		25.84	25.90	25.39		
30	1	0		24.47	24.70	23.98		
30	1	77		24.26	24.29	23.88		
30	75	0		24.96	24.82	24.36		
30	1	1	16-QAM	24.91	25.20	24.52	22.40	0.1738
30	1	1	64-QAM	23.50	23.92	23.09		
30	1	1	256-QAM	21.35	21.67	20.83		
Limit	EIRP < 1W			Result			Pass	

NR n77 HPUE Maximum Average Power [dBm] (GT - LC = -2.8 dB)								
BW [MHz]	RB Size	RB Offset	Mod	Lowest	Middle	Highest	EIRP (dBm)	EIRP(W)
40	1	1	PI/2 BPSK	25.99	26.04	25.46	23.24	0.2109
40	1	104		25.62	25.54	25.33		
40	50	25		26.01	25.92	25.35		
40	1	0		24.47	24.52	23.94		
40	1	105		24.10	24.02	23.73		
40	100	0		25.49	25.39	24.81		
40	1	1	QPSK	26.04	26.04	25.48		
40	1	104		25.69	25.57	25.34		
40	50	25		26.03	25.88	25.35		
40	1	0		24.55	24.52	24.03		
40	1	105		24.20	24.01	23.79		
40	100	0		25.01	25.37	24.33		
40	1	1	16-QAM	25.16	25.16	24.45	22.36	0.1722
40	1	1	64-QAM	23.54	23.57	22.98		
40	1	1	256-QAM	21.45	21.53	20.85		
Limit	EIRP < 1W			Result			Pass	



NR n77 HPUE Maximum Average Power [dBm] (GT - LC = -2.8 dB)										
BW [MHz]	RB Size	RB Offset	Mod	Lowest	Middle	Highest	EIRP (dBm)	EIRP(W)		
50	1	1	PI/2 BPSK	26.03	26.05	25.72	23.27	0.2123		
50	1	131		25.61	25.48	25.38				
50	64	32		25.87	25.92	25.47				
50	1	0		24.47	24.56	24.14				
50	1	132		24.12	23.97	23.81				
50	128	0		25.30	25.38	25.00				
50	1	1	QPSK	26.02	26.07	25.72			23.27	0.2123
50	1	131		25.62	25.60	25.34				
50	64	32		25.85	25.90	25.45				
50	1	0		24.54	24.63	24.16				
50	1	132		24.08	24.05	23.86				
50	128	0		24.84	24.90	24.51				
50	1	1	16-QAM	25.02	25.14	24.86	22.34	0.1714		
50	1	1	64-QAM	23.50	23.79	23.05				
50	1	1	256-QAM	21.47	21.35	21.14				
Limit	EIRP < 1W			Result			Pass			

NR n77 HPUE Maximum Average Power [dBm] (GT - LC = -2.8 dB)										
BW [MHz]	RB Size	RB Offset	Mod	Lowest	Middle	Highest	EIRP (dBm)	EIRP(W)		
60	1	1	PI/2 BPSK	26.03	25.87	25.63	23.26	0.2118		
60	1	160		25.56	25.51	25.21				
60	81	40		25.86	25.87	25.49				
60	1	0		24.61	24.38	24.12				
60	1	161		24.11	24.01	23.62				
60	162	0		25.35	25.28	24.93				
60	1	1	QPSK	26.06	25.93	25.70			23.26	0.2118
60	1	160		25.54	25.59	25.23				
60	81	40		25.91	25.89	25.44				
60	1	0		24.60	24.44	24.19				
60	1	161		24.08	24.07	23.72				
60	162	0		24.89	24.78	24.44				
60	1	1	16-QAM	25.15	25.01	24.78	22.35	0.1718		
60	1	1	64-QAM	23.81	23.45	23.32				
60	1	1	256-QAM	21.50	21.33	21.21				
Limit	EIRP < 1W			Result			Pass			



NR n77 HPUE Maximum Average Power [dBm] (GT - LC = -2.8 dB)								
BW [MHz]	RB Size	RB Offset	Mod	Lowest	Middle	Highest	EIRP (dBm)	EIRP(W)
70	1	1	PI/2 BPSK	26.13	25.88	25.65	23.33	0.2153
70	1	187		25.58	25.45	25.11		
70	90	45		25.67	25.89	25.41		
70	1	0		24.66	24.34	24.18		
70	1	188		24.05	24.03	23.61		
70	180	0		25.21	25.45	24.90		
70	1	1	QPSK	26.09	25.93	25.68		
70	1	187		25.61	25.49	25.19		
70	90	45		25.68	25.90	25.46		
70	1	0		24.67	24.36	24.23		
70	1	188		24.02	24.06	23.69		
70	180	0		24.68	24.98	24.45		
70	1	1	16-QAM	25.02	25.01	24.75	22.22	0.1667
70	1	1	64-QAM	23.59	23.35	23.23		
70	1	1	256-QAM	21.57	21.26	21.18		
Limit	EIRP < 1W			Result			Pass	

NR n77 HPUE Maximum Average Power [dBm] (GT - LC = -2.8 dB)								
BW [MHz]	RB Size	RB Offset	Mod	Lowest	Middle	Highest	EIRP (dBm)	EIRP(W)
80	1	1	PI/2 BPSK	26.08	25.78	26.12	23.33	0.2153
80	1	215		25.51	25.43	25.43		
80	108	54		25.76	25.88	25.79		
80	1	0		24.62	24.32	24.56		
80	1	216		23.92	23.87	23.91		
80	216	0		25.24	25.36	25.19		
80	1	1	QPSK	26.10	25.83	26.13		
80	1	215		25.50	25.47	25.50		
80	108	54		25.75	25.92	25.78		
80	1	0		24.63	24.30	24.61		
80	1	216		23.96	23.97	24.02		
80	216	0		24.72	24.87	24.77		
80	1	1	16-QAM	25.19	24.74	25.18	22.39	0.1734
80	1	1	64-QAM	23.70	23.33	23.77		
80	1	1	256-QAM	21.55	21.29	21.64		
Limit	EIRP < 1W			Result			Pass	



NR n77 HPUE Maximum Average Power [dBm] (GT - LC = -2.8 dB)								
BW [MHz]	RB Size	RB Offset	Mod	Lowest	Middle	Highest	EIRP (dBm)	EIRP(W)
90	1	1	PI/2 BPSK	26.20	25.91	25.67	23.40	0.2188
90	1	243		25.40	25.38	25.18		
90	120	60		25.85	25.87	25.63		
90	1	0		24.78	24.38	24.19		
90	1	244		23.97	24.01	23.72		
90	243	0		25.34	25.36	25.08		
90	1	1	QPSK	26.20	25.81	25.71		
90	1	243		25.39	25.36	25.25		
90	120	60		25.84	25.92	25.62		
90	1	0		24.74	24.33	24.25		
90	1	244		23.88	23.92	23.71		
90	243	0		24.85	24.88	24.61		
90	1	1	16-QAM	25.20	24.94	24.84	22.40	0.1738
90	1	1	64-QAM	23.69	23.30	23.07		
90	1	1	256-QAM	21.68	21.27	21.24		
Limit	EIRP < 1W			Result			Pass	

NR n77 HPUE Maximum Average Power [dBm] (GT - LC = -2.8 dB)								
BW [MHz]	RB Size	RB Offset	Mod	Lowest	Middle	Highest	EIRP (dBm)	EIRP(W)
100	1	1	PI/2 BPSK	25.80	25.40	25.46	23.13	0.2056
100	1	271		25.93	25.74	25.62		
100	135	67		25.90	25.90	25.54		
100	1	0		24.34	24.02	24.06		
100	1	272		24.42	24.27	24.17		
100	270	0		25.38	25.36	25.04		
100	1	1	QPSK	25.81	25.40	25.47		
100	1	271		25.88	25.70	25.62		
100	135	67		25.90	25.89	25.59		
100	1	0		24.35	24.02	24.13		
100	1	272		24.44	24.35	24.18		
100	270	0		24.89	24.87	24.57		
100	1	1	16-QAM	24.75	24.45	24.50	21.95	0.1567
100	1	1	64-QAM	23.40	23.02	23.00		
100	1	1	256-QAM	21.26	21.13	21.08		
Limit	EIRP < 1W			Result			Pass	



<ASDIV Antenna>

NR n77 Maximum Average Power [dBm] (GT - LC = -2.46 dB)								
BW [MHz]	RB Size	RB Offset	Mod	Lowest	Middle	Highest	EIRP (dBm)	EIRP(W)
10	1	1	PI/2 BPSK	24.31	24.04	24.20	21.85	0.1531
10	1	22		24.15	24.11	24.06		
10	12	6		24.12	24.14	24.11		
10	1	0		23.83	23.57	23.76		
10	1	23		23.62	23.62	23.59		
10	24	0		23.69	23.66	23.62		
10	1	1	QPSK	24.28	24.07	24.20		
10	1	22		24.14	24.14	24.12		
10	12	6		24.19	24.11	24.11		
10	1	0		23.28	23.53	23.21		
10	1	23		23.12	23.62	23.08		
10	24	0		23.19	23.62	23.13		
10	1	1	16-QAM	23.26	23.10	23.31	20.85	0.1216
10	1	1	64-QAM	21.72	21.44	21.62		
10	1	1	256-QAM	19.70	19.66	19.52		
Limit	EIRP < 1W			Result			Pass	

NR n77 Maximum Average Power [dBm] (GT - LC = -2.46 dB)								
BW [MHz]	RB Size	RB Offset	Mod	Lowest	Middle	Highest	EIRP (dBm)	EIRP(W)
15	1	1	PI/2 BPSK	24.35	24.06	24.13	21.89	0.1545
15	1	36		24.12	24.16	23.95		
15	18	9		24.18	24.00	24.12		
15	1	0		23.79	23.58	23.70		
15	1	37		23.50	23.62	23.50		
15	36	0		23.69	23.51	23.60		
15	1	1	QPSK	24.30	24.04	24.12		
15	1	36		24.18	24.07	23.95		
15	18	9		24.17	24.01	24.13		
15	1	0		23.31	23.01	23.17		
15	1	37		22.99	23.05	22.94		
15	36	0		23.19	23.09	23.11		
15	1	1	16-QAM	23.46	23.15	23.02	21.00	0.1259
15	1	1	64-QAM	21.94	21.64	21.51		
15	1	1	256-QAM	19.73	19.43	19.59		
Limit	EIRP < 1W			Result			Pass	



NR n77 Maximum Average Power [dBm] (GT - LC = -2.46 dB)								
BW [MHz]	RB Size	RB Offset	Mod	Lowest	Middle	Highest	EIRP (dBm)	EIRP(W)
20	1	1	PI/2 BPSK	24.35	24.11	24.24	21.89	0.1545
20	1	49		23.96	24.10	24.12		
20	25	12		24.18	24.03	24.14		
20	1	0		23.82	23.57	23.71		
20	1	50		23.50	23.46	23.48		
20	50	0		23.66	23.53	23.62		
20	1	1	QPSK	24.31	24.07	24.22		
20	1	49		23.97	24.10	23.96		
20	25	12		24.17	24.01	24.17		
20	1	0		23.32	23.06	23.20		
20	1	50		22.96	22.95	22.93		
20	50	0		23.16	23.01	23.11		
20	1	1	16-QAM	23.41	23.18	23.40	20.95	0.1245
20	1	1	64-QAM	21.78	21.62	21.63		
20	1	1	256-QAM	19.74	19.55	19.59		
Limit	EIRP < 1W			Result			Pass	

NR n77 Maximum Average Power [dBm] (GT - LC = -2.46 dB)								
BW [MHz]	RB Size	RB Offset	Mod	Lowest	Middle	Highest	EIRP (dBm)	EIRP(W)
25	1	1	PI/2 BPSK	24.37	24.25	24.41	21.95	0.1567
25	1	63		24.08	23.97	24.04		
25	32	16		24.17	24.04	24.21		
25	1	0		23.87	23.72	23.91		
25	1	64		23.59	23.44	23.53		
25	64	0		23.69	23.51	23.70		
25	1	1	QPSK	24.35	24.26	24.38		
25	1	63		24.10	23.94	24.02		
25	32	16		24.20	24.01	24.23		
25	1	0		23.35	23.27	23.40		
25	1	64		23.06	22.94	23.02		
25	64	0		23.17	23.06	23.20		
25	1	1	16-QAM	23.30	23.42	23.55	21.09	0.1285
25	1	1	64-QAM	21.84	21.81	21.92		
25	1	1	256-QAM	19.81	19.72	19.80		
Limit	EIRP < 1W			Result			Pass	



NR n77 Maximum Average Power [dBm] (GT - LC = -2.46 dB)								
BW [MHz]	RB Size	RB Offset	Mod	Lowest	Middle	Highest	EIRP (dBm)	EIRP(W)
30	1	1	PI/2 BPSK	24.36	24.32	24.33	21.90	0.1549
30	1	76		24.08	24.02	23.92		
30	36	18		24.18	24.10	24.24		
30	1	0		23.90	23.83	23.93		
30	1	77		23.56	23.49	23.49		
30	75	0		23.58	23.53	23.73		
30	1	1	QPSK	24.33	24.30	24.36	21.90	0.1549
30	1	76		24.08	23.94	23.92		
30	36	18		24.17	24.08	24.20		
30	1	0		23.37	23.28	23.35		
30	1	77		23.03	22.91	22.90		
30	75	0		23.10	23.05	23.19		
30	1	1	16-QAM	23.43	23.35	23.30	20.97	0.1250
30	1	1	64-QAM	21.97	21.94	21.84		
30	1	1	256-QAM	19.79	19.75	19.75		
Limit	EIRP < 1W			Result			Pass	

NR n77 Maximum Average Power [dBm] (GT - LC = -2.46 dB)								
BW [MHz]	RB Size	RB Offset	Mod	Lowest	Middle	Highest	EIRP (dBm)	EIRP(W)
40	1	1	PI/2 BPSK	24.42	24.26	24.54	22.08	0.1614
40	1	104		23.93	24.12	24.06		
40	50	25		24.06	24.06	24.35		
40	1	0		23.85	23.75	24.07		
40	1	105		23.41	23.55	23.52		
40	100	0		23.57	23.55	23.85		
40	1	1	QPSK	24.34	24.23	24.50	22.08	0.1614
40	1	104		23.89	24.08	24.02		
40	50	25		24.08	24.05	24.38		
40	1	0		23.34	23.23	23.48		
40	1	105		22.88	23.09	22.98		
40	100	0		23.06	23.05	23.33		
40	1	1	16-QAM	23.32	23.40	23.67	21.21	0.1321
40	1	1	64-QAM	22.07	21.62	21.96		
40	1	1	256-QAM	19.73	19.67	19.86		
Limit	EIRP < 1W			Result			Pass	



NR n77 Maximum Average Power [dBm] (GT - LC = -2.46 dB)										
BW [MHz]	RB Size	RB Offset	Mod	Lowest	Middle	Highest	EIRP (dBm)	EIRP(W)		
50	1	1	PI/2 BPSK	24.41	24.20	24.50	22.04	0.1600		
50	1	131		23.72	24.04	23.94				
50	64	32		24.12	24.07	24.37				
50	1	0		23.85	23.73	24.04				
50	1	132		23.19	23.60	23.43				
50	128	0		23.59	23.53	23.83				
50	1	1	QPSK	24.43	24.20	24.50			21.19	0.1315
50	1	131		23.70	24.02	23.91				
50	64	32		24.12	24.09	24.35				
50	1	0		23.37	23.17	23.52				
50	1	132		22.67	23.03	22.94				
50	128	0		23.10	23.01	23.34				
50	1	1	16-QAM	23.49	23.21	23.65	21.19	0.1315		
50	1	1	64-QAM	21.99	21.57	21.88				
50	1	1	256-QAM	19.73	19.50	19.87				
Limit	EIRP < 1W			Result			Pass			

NR n77 Maximum Average Power [dBm] (GT - LC = -2.46 dB)										
BW [MHz]	RB Size	RB Offset	Mod	Lowest	Middle	Highest	EIRP (dBm)	EIRP(W)		
60	1	1	PI/2 BPSK	24.10	23.93	24.12	21.66	0.1466		
60	1	160		23.56	23.76	23.98				
60	81	40		23.79	23.98	24.00				
60	1	0		23.61	23.45	23.56				
60	1	161		23.04	23.22	23.47				
60	162	0		23.26	23.38	23.46				
60	1	1	QPSK	24.10	23.98	24.08			20.79	0.1199
60	1	160		23.57	23.79	24.01				
60	81	40		23.82	24.00	24.00				
60	1	0		23.07	22.93	23.08				
60	1	161		22.54	22.70	22.91				
60	162	0		22.76	22.90	22.95				
60	1	1	16-QAM	23.05	23.17	23.25	20.79	0.1199		
60	1	1	64-QAM	21.70	21.61	21.66				
60	1	1	256-QAM	19.56	19.41	19.51				
Limit	EIRP < 1W			Result			Pass			



NR n77 Maximum Average Power [dBm] (GT - LC = -2.46 dB)								
BW [MHz]	RB Size	RB Offset	Mod	Lowest	Middle	Highest	EIRP (dBm)	EIRP(W)
70	1	1	PI/2 BPSK	24.29	23.89	24.39	22.00	0.1585
70	1	187		24.00	23.66	24.43		
70	90	45		24.00	23.94	23.97		
70	1	0		23.95	23.30	23.91		
70	1	188		23.54	23.10	23.56		
70	180	0		23.52	23.43	23.53		
70	1	1	QPSK	24.46	23.85	24.40	22.00	0.1585
70	1	187		24.10	23.69	24.46		
70	90	45		24.00	23.96	24.02		
70	1	0		23.43	22.85	23.41		
70	1	188		23.05	22.62	23.07		
70	180	0		22.98	22.92	23.01		
70	1	1	16-QAM	23.56	23.03	23.56	21.10	0.1288
70	1	1	64-QAM	21.99	21.34	21.91		
70	1	1	256-QAM	19.93	19.20	19.92		
Limit	EIRP < 1W			Result			Pass	

NR n77 Maximum Average Power [dBm] (GT - LC = -2.46 dB)								
BW [MHz]	RB Size	RB Offset	Mod	Lowest	Middle	Highest	EIRP (dBm)	EIRP(W)
80	1	1	PI/2 BPSK	24.17	23.93	24.46	22.04	0.1600
80	1	215		23.51	23.66	23.97		
80	108	54		23.75	23.94	24.06		
80	1	0		23.62	23.43	24.03		
80	1	216		22.99	23.14	23.57		
80	216	0		23.26	23.42	23.57		
80	1	1	QPSK	24.13	23.92	24.50	22.04	0.1600
80	1	215		23.47	23.80	24.06		
80	108	54		23.75	23.97	24.07		
80	1	0		23.16	22.88	23.53		
80	1	216		22.47	22.68	23.04		
80	216	0		22.74	22.91	23.03		
80	1	1	16-QAM	23.30	23.01	23.40	20.94	0.1242
80	1	1	64-QAM	21.64	21.50	22.08		
80	1	1	256-QAM	19.44	19.44	19.63		
Limit	EIRP < 1W			Result			Pass	



NR n77 Maximum Average Power [dBm] (GT - LC = -2.46 dB)								
BW [MHz]	RB Size	RB Offset	Mod	Lowest	Middle	Highest	EIRP (dBm)	EIRP(W)
90	1	1	PI/2 BPSK	24.15	23.48	24.05	21.86	0.1535
90	1	243		23.61	23.45	23.95		
90	120	60		23.72	23.66	24.30		
90	1	0		23.70	23.00	24.09		
90	1	244		23.19	22.99	23.51		
90	243	0		23.23	23.12	23.85		
90	1	1	QPSK	24.18	23.50	24.32	21.04	0.1271
90	1	243		23.62	23.48	23.93		
90	120	60		23.72	23.65	24.20		
90	1	0		23.18	22.50	23.40		
90	1	244		22.62	22.39	22.92		
90	243	0		22.70	22.60	23.18		
90	1	1	16-QAM	23.20	22.53	23.50	21.04	0.1271
90	1	1	64-QAM	21.96	21.20	22.25		
90	1	1	256-QAM	19.80	19.26	20.08		
Limit	EIRP < 1W			Result			Pass	

NR n77 Maximum Average Power [dBm] (GT - LC = -2.46 dB)								
BW [MHz]	RB Size	RB Offset	Mod	Lowest	Middle	Highest	EIRP (dBm)	EIRP(W)
100	1	1	PI/2 BPSK	23.85	23.50	24.34	21.98	0.1578
100	1	271		24.21	24.10	24.44		
100	135	67		23.77	23.96	24.13		
100	1	0		23.42	23.00	23.85		
100	1	272		23.76	23.48	23.95		
100	270	0		23.28	23.41	23.62		
100	1	1	QPSK	23.85	23.45	24.31	20.81	0.1205
100	1	271		24.23	23.96	24.40		
100	135	67		23.73	23.96	24.16		
100	1	0		22.83	22.47	23.30		
100	1	272		23.25	22.99	23.42		
100	270	0		22.75	22.91	23.10		
100	1	1	16-QAM	22.98	22.51	23.27	20.81	0.1205
100	1	1	64-QAM	21.40	21.11	21.80		
100	1	1	256-QAM	19.38	18.45	19.90		
Limit	EIRP < 1W			Result			Pass	



NR n77 HPUE Maximum Average Power [dBm] (GT - LC = -2.46 dB)								
BW [MHz]	RB Size	RB Offset	Mod	Lowest	Middle	Highest	EIRP (dBm)	EIRP(W)
10	1	1	PI/2 BPSK	25.01	24.84	24.01	22.57	0.1807
10	1	22		24.86	24.98	23.79		
10	12	6		24.92	24.96	23.87		
10	1	0		23.54	23.42	23.94		
10	1	23		23.36	23.41	23.76		
10	24	0		24.43	24.43	23.87		
10	1	1	QPSK	25.03	24.87	23.93		
10	1	22		24.84	24.94	23.77		
10	12	6		24.92	24.95	23.89		
10	1	0		23.42	23.42	23.92		
10	1	23		23.36	23.41	23.74		
10	24	0		23.93	23.92	23.86		
10	1	1	16-QAM	23.92	23.98	23.96	21.52	0.1419
10	1	1	64-QAM	22.64	22.54	23.31		
10	1	1	256-QAM	20.54	20.34	21.45		
Limit	EIRP < 1W			Result			Pass	

NR n77 HPUE Maximum Average Power [dBm] (GT - LC = -2.46 dB)								
BW [MHz]	RB Size	RB Offset	Mod	Lowest	Middle	Highest	EIRP (dBm)	EIRP(W)
15	1	1	PI/2 BPSK	24.82	24.61	24.08	22.47	0.1766
15	1	36		24.62	24.57	23.86		
15	18	9		24.75	24.51	24.01		
15	1	0		23.39	23.02	24.15		
15	1	37		23.28	23.03	23.86		
15	36	0		24.24	24.01	24.10		
15	1	1	QPSK	24.93	24.58	24.11		
15	1	36		24.85	24.62	23.85		
15	18	9		24.77	24.51	24.03		
15	1	0		23.42	23.05	24.15		
15	1	37		23.05	23.09	23.84		
15	36	0		23.78	23.45	24.01		
15	1	1	16-QAM	23.82	23.98	24.12	21.66	0.1466
15	1	1	64-QAM	22.34	22.21	23.54		
15	1	1	256-QAM	20.62	20.54	21.53		
Limit	EIRP < 1W			Result			Pass	



NR n77 HPUE Maximum Average Power [dBm] (GT - LC = -2.46 dB)								
BW [MHz]	RB Size	RB Offset	Mod	Lowest	Middle	Highest	EIRP (dBm)	EIRP(W)
20	1	1	PI/2 BPSK	24.61	24.92	24.06	22.48	0.177
20	1	49		24.52	24.94	23.73		
20	25	12		24.62	24.53	23.92		
20	1	0		23.15	23.07	24.11		
20	1	50		23.03	23.21	23.74		
20	50	0		24.08	24.04	23.93		
20	1	1	QPSK	24.68	24.57	24.06		
20	1	49		24.54	24.62	23.76		
20	25	12		24.61	24.51	23.92		
20	1	0		23.21	23.06	24.09		
20	1	50		23.06	23.03	23.74		
20	50	0		23.61	23.54	23.95		
20	1	1	16-QAM	23.65	23.56	24.23	21.77	0.1503
20	1	1	64-QAM	22.06	22.05	23.51		
20	1	1	256-QAM	20.19	20.45	21.56		
Limit	EIRP < 1W			Result			Pass	

NR n77 HPUE Maximum Average Power [dBm] (GT - LC = -2.46 dB)								
BW [MHz]	RB Size	RB Offset	Mod	Lowest	Middle	Highest	EIRP (dBm)	EIRP(W)
25	1	1	PI/2 BPSK	25.21	25.13	24.23	22.80	0.1905
25	1	63		24.87	24.77	23.74		
25	32	16		25.05	24.84	24.01		
25	1	0		23.74	23.59	24.23		
25	1	64		23.35	23.29	23.72		
25	64	0		24.53	24.33	23.98		
25	1	1	QPSK	25.26	25.08	24.24		
25	1	63		24.91	24.75	23.76		
25	32	16		25.01	24.86	24.03		
25	1	0		23.74	23.59	24.26		
25	1	64		23.39	23.25	23.72		
25	64	0		24.02	23.87	24.01		
25	1	1	16-QAM	24.08	24.06	24.26	21.80	0.1514
25	1	1	64-QAM	22.84	22.65	23.71		
25	1	1	256-QAM	20.75	20.54	21.62		
Limit	EIRP < 1W			Result			Pass	



NR n77 HPUE Maximum Average Power [dBm] (GT - LC = -2.46 dB)								
BW [MHz]	RB Size	RB Offset	Mod	Lowest	Middle	Highest	EIRP (dBm)	EIRP(W)
30	1	1	PI/2 BPSK	25.13	25.13	24.35	22.69	0.1858
30	1	76		24.77	24.75	23.81		
30	36	18		24.93	24.89	24.17		
30	1	0		23.61	23.64	24.42		
30	1	77		23.26	23.26	23.81		
30	75	0		24.31	24.37	24.18		
30	1	1	QPSK	25.11	25.15	24.39	22.69	0.1858
30	1	76		24.76	24.78	23.81		
30	36	18		24.95	24.95	24.20		
30	1	0		23.63	23.65	24.41		
30	1	77		23.27	23.28	23.82		
30	75	0		23.84	23.85	24.16		
30	1	1	16-QAM	23.98	24.12	24.54	22.08	0.1614
30	1	1	64-QAM	22.74	22.72	24.01		
30	1	1	256-QAM	20.52	20.75	21.84		
Limit	EIRP < 1W			Result			Pass	

NR n77 HPUE Maximum Average Power [dBm] (GT - LC = -2.46 dB)								
BW [MHz]	RB Size	RB Offset	Mod	Lowest	Middle	Highest	EIRP (dBm)	EIRP(W)
40	1	1	PI/2 BPSK	25.21	25.10	24.40	22.78	0.1897
40	1	104		24.69	24.88	23.73		
40	50	25		24.90	24.88	24.17		
40	1	0		23.72	23.64	24.42		
40	1	105		23.21	23.38	23.70		
40	100	0		24.42	24.34	24.22		
40	1	1	QPSK	25.24	25.16	24.41	22.78	0.1897
40	1	104		24.72	24.92	23.71		
40	50	25		24.92	24.87	24.16		
40	1	0		23.69	23.64	24.41		
40	1	105		23.24	23.41	23.70		
40	100	0		23.88	23.87	24.15		
40	1	1	16-QAM	24.21	24.01	24.27	21.81	0.1517
40	1	1	64-QAM	22.75	22.54	23.72		
40	1	1	256-QAM	20.65	20.54	21.86		
Limit	EIRP < 1W			Result			Pass	



NR n77 HPUE Maximum Average Power [dBm] (GT - LC = -2.46 dB)								
BW [MHz]	RB Size	RB Offset	Mod	Lowest	Middle	Highest	EIRP (dBm)	EIRP(W)
50	1	1	PI/2 BPSK	25.18	25.05	24.55	22.72	0.1871
50	1	131		24.52	24.84	23.76		
50	64	32		24.88	24.85	24.37		
50	1	0		23.69	23.54	24.57		
50	1	132		23.02	23.35	23.75		
50	128	0		24.37	24.35	23.34		
50	1	1	QPSK	25.16	25.07	24.57		
50	1	131		24.48	24.85	23.78		
50	64	32		24.89	24.86	24.37		
50	1	0		23.67	23.54	24.56		
50	1	132		23.01	23.35	23.75		
50	128	0		23.88	23.84	24.34		
50	1	1	16-QAM	24.15	24.10	24.54	22.08	0.1614
50	1	1	64-QAM	22.64	22.56	23.92		
50	1	1	256-QAM	20.65	20.57	22.09		
Limit	EIRP < 1W			Result			Pass	

NR n77 HPUE Maximum Average Power [dBm] (GT - LC = -2.46 dB)								
BW [MHz]	RB Size	RB Offset	Mod	Lowest	Middle	Highest	EIRP (dBm)	EIRP(W)
60	1	1	PI/2 BPSK	25.27	25.04	24.51	22.81	0.1910
60	1	160		24.66	24.72	23.67		
60	81	40		24.95	24.85	24.34		
60	1	0		23.78	23.57	24.49		
60	1	161		22.96	23.22	23.65		
60	162	0		24.54	24.45	24.27		
60	1	1	QPSK	25.24	25.07	24.51		
60	1	160		24.75	24.74	23.71		
60	81	40		24.94	24.97	24.32		
60	1	0		23.73	23.57	24.53		
60	1	161		22.96	23.24	23.66		
60	162	0		23.92	23.94	24.28		
60	1	1	16-QAM	24.27	24.09	24.35	21.89	0.1545
60	1	1	64-QAM	22.84	22.72	24.02		
60	1	1	256-QAM	20.74	20.57	22.11		
Limit	EIRP < 1W			Result			Pass	



NR n77 HPUE Maximum Average Power [dBm] (GT - LC = -2.46 dB)								
BW [MHz]	RB Size	RB Offset	Mod	Lowest	Middle	Highest	EIRP (dBm)	EIRP(W)
70	1	1	PI/2 BPSK	25.26	25.07	24.72	22.81	0.1910
70	1	187		24.55	24.81	23.64		
70	90	45		24.82	24.89	24.24		
70	1	0		23.88	23.57	24.71		
70	1	188		23.05	23.22	23.63		
70	180	0		24.33	24.36	24.23		
70	1	1	QPSK	25.27	25.05	24.74		
70	1	187		24.59	24.86	23.64		
70	90	45		24.84	24.87	24.26		
70	1	0		23.80	23.59	24.75		
70	1	188		23.10	23.26	23.67		
70	180	0		23.85	23.80	24.23		
70	1	1	16-QAM	24.19	23.98	24.75	22.29	0.1694
70	1	1	64-QAM	22.76	22.65	24.29		
70	1	1	256-QAM	20.86	20.62	22.44		
Limit	EIRP < 1W			Result			Pass	

NR n77 HPUE Maximum Average Power [dBm] (GT - LC = -2.46 dB)								
BW [MHz]	RB Size	RB Offset	Mod	Lowest	Middle	Highest	EIRP (dBm)	EIRP(W)
80	1	1	PI/2 BPSK	25.35	25.02	24.94	22.90	0.1950
80	1	215		24.43	24.65	23.65		
80	108	54		24.89	24.88	24.33		
80	1	0		23.89	23.56	24.88		
80	1	216		22.96	23.12	23.61		
80	216	0		24.38	24.37	24.29		
80	1	1	QPSK	25.36	25.06	24.93		
80	1	215		24.45	24.59	23.61		
80	108	54		24.88	24.87	24.34		
80	1	0		23.89	23.61	24.95		
80	1	216		22.98	23.13	23.58		
80	216	0		23.87	23.89	24.32		
80	1	1	16-QAM	24.35	24.14	25.02	22.56	0.1803
80	1	1	64-QAM	22.88	22.57	24.56		
80	1	1	256-QAM	20.94	20.54	22.59		
Limit	EIRP < 1W			Result			Pass	



NR n77 HPUE Maximum Average Power [dBm] (GT - LC = -2.46 dB)								
BW [MHz]	RB Size	RB Offset	Mod	Lowest	Middle	Highest	EIRP (dBm)	EIRP(W)
90	1	1	PI/2 BPSK	25.37	25.02	24.98	22.91	0.1954
90	1	243		24.52	24.54	23.53		
90	120	60		24.71	24.87	24.41		
90	1	0		23.92	23.54	25.01		
90	1	244		23.04	23.08	23.52		
90	243	0		24.23	24.36	24.99		
90	1	1	QPSK	25.34	25.02	24.95		
90	1	243		24.49	24.52	23.54		
90	120	60		24.68	24.91	24.39		
90	1	0		23.91	23.56	24.96		
90	1	244		23.05	23.07	23.54		
90	243	0		23.72	23.86	24.33		
90	1	1	16-QAM	24.31	24.10	24.92	22.46	0.1762
90	1	1	64-QAM	22.89	22.64	24.61		
90	1	1	256-QAM	21.01	20.59	22.63		
Limit	EIRP < 1W			Result			Pass	

NR n77 HPUE Maximum Average Power [dBm] (GT - LC = -2.46 dB)								
BW [MHz]	RB Size	RB Offset	Mod	Lowest	Middle	Highest	EIRP (dBm)	EIRP(W)
100	1	1	PI/2 BPSK	25.04	24.61	24.27	22.81	0.1910
100	1	271		25.05	25.24	23.97		
100	135	67		24.74	24.87	24.34		
100	1	0		23.59	23.16	24.28		
100	1	272		23.61	23.82	23.96		
100	270	0		24.25	24.37	24.30		
100	1	1	QPSK	24.94	24.48	24.25		
100	1	271		24.96	25.27	23.97		
100	135	67		24.76	24.87	24.34		
100	1	0		23.51	23.18	24.29		
100	1	272		23.56	23.94	23.98		
100	270	0		23.75	23.87	24.29		
100	1	1	16-QAM	24.07	23.56	24.09	21.63	0.1455
100	1	1	64-QAM	22.65	22.14	23.62		
100	1	1	256-QAM	20.46	20.24	22.02		
Limit	EIRP < 1W			Result			Pass	



<MIMO Antenna>

Part270 NR n77 Maximum Average Power [dBm], DG = -2.8 dBi														
BW	RB	RB	Mod	Antenna 6			Antenna 1			Combine			EIRP	EIRP
(MHz)	Size	Offset		Lowest	Middle	Highest	Lowest	Middle	Highest	Lowest	Middle	Highest	(dBm)	(W)
10	1	1	QPSK	22.65	22.45	22.03	22.82	23.42	22.92	25.75	25.97	25.51	23.17	0.2075
10	1	22		22.48	22.43	22.03	22.77	23.33	22.75	25.64	25.91	25.42		
10	12	6		22.54	22.36	22.02	22.79	23.41	22.79	25.68	25.93	25.43		
10	1	0		20.74	20.55	20.06	20.89	21.41	20.83	23.83	24.01	23.47		
10	1	23		20.50	20.43	20.03	20.76	21.26	20.65	23.64	23.88	23.36		
10	24	0		21.12	20.42	20.53	21.33	21.87	21.26	24.24	24.22	23.92		
10	1	1	16-QAM	22.17	21.87	21.41	22.37	22.99	22.46	25.28	25.48	24.98	22.68	0.1854
10	1	1	64-QAM	20.61	20.43	20.04	20.56	21.21	20.70	23.60	23.85	23.39		
10	1	1	256-QAM	17.71	17.51	17.02	17.57	18.18	17.77	20.65	20.87	20.42		
Limit	EIRP < 1W			Result									Pass	

Part270 NR n77 Maximum Average Power [dBm], DG = -2.8 dBi														
BW	RB	RB	Mod	Antenna 6			Antenna 1			Combine			EIRP	EIRP
(MHz)	Size	Offset		Lowest	Middle	Highest	Lowest	Middle	Highest	Lowest	Middle	Highest	(dBm)	(W)
15	1	1	QPSK	22.72	22.47	22.08	22.83	23.43	22.76	25.79	25.99	25.44	23.19	0.2084
15	1	36		22.65	22.31	22.15	22.81	23.42	22.70	25.74	25.91	25.44		
15	19	9		22.65	22.45	22.13	22.86	23.35	22.73	25.77	25.93	25.45		
15	1	0		20.80	20.55	20.12	20.88	21.50	20.78	23.85	24.06	23.47		
15	1	37		20.68	20.29	20.04	20.91	21.36	20.59	23.81	23.87	23.33		
15	38	0		21.16	20.85	20.58	21.36	21.91	21.20	24.27	24.42	23.91		
15	1	1	16-QAM	22.15	22.03	21.56	22.33	23.05	22.21	25.25	25.58	24.91	22.78	0.1897
15	1	1	64-QAM	20.66	20.47	20.01	20.83	21.43	20.82	23.76	23.99	23.44		
15	1	1	256-QAM	17.68	17.45	17.01	17.84	18.39	17.79	20.77	20.96	20.43		
Limit	EIRP < 1W			Result									Pass	



Part270 NR n77 Maximum Average Power [dBm], DG = -2.8 dBi														
BW	RB	RB	Mod	Antenna 6			Antenna 1			Combine			EIRP	EIRP
(MHz)	Size	Offset		Lowest	Middle	Highest	Lowest	Middle	Highest	Lowest	Middle	Highest	(dBm)	(W)
20	1	1	QPSK	22.81	22.47	21.90	22.95	23.43	23.05	25.89	25.99	25.52	23.19	0.2084
20	1	49		22.65	22.17	21.95	22.86	23.29	22.78	25.77	25.78	25.40		
20	25	12		22.70	22.45	22.02	22.91	23.40	22.87	25.82	25.96	25.48		
20	1	0		20.75	20.46	19.97	20.95	21.46	20.90	23.86	24.00	23.47		
20	1	50		20.68	20.37	19.94	20.90	21.32	20.72	23.80	23.88	23.36		
20	51	0		21.13	20.73	20.53	21.45	21.85	21.37	24.30	24.34	23.98		
20	1	1	16-QAM	22.13	22.05	21.49	22.41	22.88	22.36	25.28	25.50	24.96	22.70	0.1862
20	1	1	64-QAM	20.69	20.44	20.00	20.77	21.32	20.92	23.74	23.91	23.49		
20	1	1	256-QAM	17.58	17.44	16.97	17.93	18.25	17.87	20.77	20.87	20.45		
Limit	EIRP < 1W			Result									Pass	

Part270 NR n77 Maximum Average Power [dBm], DG = -2.8 dBi														
BW	RB	RB	Mod	Antenna 6			Antenna 1			Combine			EIRP	EIRP
(MHz)	Size	Offset		Lowest	Middle	Highest	Lowest	Middle	Highest	Lowest	Middle	Highest	(dBm)	(W)
25	1	1	QPSK	22.78	22.62	22.04	23.03	23.59	23.01	25.92	26.14	25.56	23.34	0.2158
25	1	63		22.69	22.27	22.03	22.76	23.28	22.73	25.74	25.81	25.40		
25	33	16		22.72	22.26	22.01	23.01	23.45	22.83	25.88	25.91	25.45		
25	1	0		20.88	20.68	20.00	21.02	21.57	20.95	23.96	24.16	23.51		
25	1	64		20.67	20.44	20.01	20.70	21.29	20.72	23.70	23.90	23.39		
25	65	0		21.23	20.88	20.52	21.47	21.92	21.29	24.36	24.44	23.93		
25	1	1	16-QAM	22.20	22.27	21.62	22.54	23.09	22.49	25.38	25.71	25.09	22.91	0.1954
25	1	1	64-QAM	20.88	20.72	20.10	21.01	21.36	20.88	23.96	24.06	23.52		
25	1	1	256-QAM	17.78	17.44	17.06	17.97	18.56	17.80	20.89	21.05	20.46		
Limit	EIRP < 1W			Result									Pass	



Part270 NR n77 Maximum Average Power [dBm], DG = -2.8 dBi														
BW	RB	RB	Mod	Antenna 6			Antenna 1			Combine			EIRP	EIRP
(MHz)	Size	Offset		Lowest	Middle	Highest	Lowest	Middle	Highest	Lowest	Middle	Highest	(dBm)	(W)
30	1	1	QPSK	22.77	22.75	22.27	22.96	23.66	23.08	25.88	26.24	25.70	23.44	0.2208
30	1	76		22.43	22.31	22.04	22.67	23.30	22.88	25.56	25.84	25.49		
30	39	19		22.74	22.52	22.19	22.87	23.46	23.03	25.82	26.03	25.64		
30	1	0		20.83	20.75	20.16	20.91	21.65	21.12	23.88	24.23	23.68		
30	1	77		20.54	20.36	20.13	20.61	21.28	20.50	23.59	23.85	23.33		
30	78	0		21.24	20.85	20.54	21.46	21.85	21.52	24.36	24.39	24.07		
30	1	1	16-QAM	22.34	22.44	21.77	22.47	23.19	22.52	25.42	25.84	25.17	23.04	0.2014
30	1	1	64-QAM	20.75	20.78	20.11	20.91	21.52	21.01	23.84	24.18	23.59		
30	1	1	256-QAM	17.71	17.62	16.93	18.01	18.53	18.04	20.87	21.11	20.53		
Limit	EIRP < 1W			Result									Pass	

Part270 NR n77 Maximum Average Power [dBm], DG = -2.8 dBi														
BW	RB	RB	Mod	Antenna 6			Antenna 1			Combine			EIRP	EIRP
(MHz)	Size	Offset		Lowest	Middle	Highest	Lowest	Middle	Highest	Lowest	Middle	Highest	(dBm)	(W)
40	1	1	QPSK	22.77	22.67	22.12	22.96	23.51	23.02	25.88	26.12	25.60	23.32	0.2148
40	1	104		22.52	22.10	21.97	22.73	23.20	22.75	25.64	25.70	25.39		
40	53	26		22.76	22.47	21.95	22.94	23.42	22.94	25.86	25.98	25.48		
40	1	0		20.83	20.69	20.07	20.91	21.47	20.94	23.88	24.11	23.54		
40	1	105		20.40	20.14	19.90	20.70	21.12	20.72	23.56	23.67	23.34		
40	106	0		21.28	20.91	20.52	21.40	21.94	21.40	24.35	24.47	23.99		
40	1	1	16-QAM	22.13	22.10	21.57	22.54	22.97	22.53	25.35	25.57	25.09	22.77	0.1892
40	1	1	64-QAM	20.91	20.68	19.96	20.85	21.53	20.84	23.89	24.14	23.43		
40	1	1	256-QAM	17.74	17.45	17.06	17.93	18.41	17.84	20.85	20.97	20.48		
Limit	EIRP < 1W			Result									Pass	



Part270 NR n77 Maximum Average Power [dBm], DG = -2.8 dBi														
BW	RB	RB	Mod	Antenna 6			Antenna 1			Combine			EIRP	EIRP
(MHz)	Size	Offset		Lowest	Middle	Highest	Lowest	Middle	Highest	Lowest	Middle	Highest	(dBm)	(W)
50	1	1	QPSK	22.79	22.63	22.45	23.00	23.51	23.15	25.91	26.10	25.82	23.30	0.2138
50	1	131		22.44	22.10	22.06	22.89	23.14	22.73	25.68	25.66	25.42		
50	67	33		22.68	22.42	22.17	22.75	23.48	23.05	25.73	25.99	25.64		
50	1	0		20.86	20.67	20.42	21.00	21.47	20.46	23.94	24.10	23.45		
50	1	132		20.52	20.12	20.03	20.90	21.08	20.65	23.72	23.64	23.36		
50	133	0		21.12	20.89	20.65	21.21	21.90	21.40	24.18	24.43	24.05		
50	1	1	16-QAM	22.38	22.21	21.82	22.41	22.90	22.66	25.41	25.58	25.27	22.78	0.1897
50	1	1	64-QAM	20.86	20.50	20.33	20.95	21.43	21.07	23.92	24.00	23.73		
50	1	1	256-QAM	17.58	17.67	17.25	17.82	18.31	18.00	20.71	21.01	20.65		
Limit	EIRP < 1W			Result									Pass	

Part270 NR n77 Maximum Average Power [dBm], DG = -2.8 dBi														
BW	RB	RB	Mod	Antenna 6			Antenna 1			Combine			EIRP	EIRP
(MHz)	Size	Offset		Lowest	Middle	Highest	Lowest	Middle	Highest	Lowest	Middle	Highest	(dBm)	(W)
60	1	1	QPSK	22.87	22.63	22.32	23.00	23.46	23.02	25.95	26.08	25.69	23.28	0.2128
60	1	160		22.33	22.24	22.04	22.54	23.14	22.59	25.45	25.72	25.33		
60	81	40		22.68	22.52	22.17	22.81	23.41	22.91	25.76	26.00	25.57		
60	1	0		20.85	20.61	20.40	20.96	21.42	21.03	23.92	24.04	23.74		
60	1	161		20.21	20.13	20.00	20.84	21.08	20.63	23.55	23.64	23.34		
60	162	0		21.19	20.86	20.60	21.26	21.89	21.33	24.24	24.42	23.99		
60	1	1	16-QAM	22.36	22.06	21.97	22.70	23.08	22.49	25.54	25.61	25.25	22.81	0.1910
60	1	1	64-QAM	20.79	20.60	20.25	21.03	21.50	21.03	23.92	24.08	23.67		
60	1	1	256-QAM	17.81	17.45	17.46	17.91	18.42	18.09	20.87	20.97	20.80		
Limit	EIRP < 1W			Result									Pass	



Part270 NR n77 Maximum Average Power [dBm], DG = -2.8 dBi														
BW	RB	RB	Mod	Antenna 6			Antenna 1			Combine			EIRP	EIRP
(MHz)	Size	Offset		Lowest	Middle	Highest	Lowest	Middle	Highest	Lowest	Middle	Highest	(dBm)	(W)
70	1	1	QPSK	22.84	22.43	21.80	22.97	23.37	22.72	25.92	25.94	25.29	23.14	0.2061
70	1	187		22.10	22.05	21.34	22.80	23.15	22.08	25.47	25.65	24.74		
70	95	47		22.43	22.35	21.58	22.79	23.44	22.30	25.62	25.94	24.97		
70	1	0		20.83	20.54	20.45	20.80	21.36	21.24	23.83	23.98	23.87		
70	1	188		20.24	20.15	19.89	20.83	21.04	20.53	23.56	23.63	23.23		
70	189	0		20.88	20.80	20.59	21.27	21.89	21.30	24.09	24.39	23.97		
70	1	1	16-QAM	22.34	21.92	21.98	22.27	22.84	22.84	25.32	25.41	25.44	22.64	0.1837
70	1	1	64-QAM	20.86	20.42	20.29	20.90	21.34	21.13	23.89	23.91	23.74		
70	1	1	256-QAM	17.78	17.52	17.35	17.70	18.29	18.21	20.75	20.93	20.81		
Limit	EIRP < 1W			Result									Pass	

Part270 NR n77 Maximum Average Power [dBm], DG = -2.8 dBi														
BW	RB	RB	Mod	Antenna 6			Antenna 1			Combine			EIRP	EIRP
(MHz)	Size	Offset		Lowest	Middle	Highest	Lowest	Middle	Highest	Lowest	Middle	Highest	(dBm)	(W)
80	1	1	QPSK	22.89	22.45	22.57	23.11	23.36	23.14	26.01	25.94	25.87	23.21	0.2094
80	1	215		22.22	22.12	21.36	22.73	22.86	21.89	25.49	25.52	24.64		
80	109	54		22.51	22.37	21.66	22.97	23.42	22.17	25.76	25.94	24.93		
80	1	0		20.91	20.45	20.50	21.08	21.36	21.09	24.01	23.94	23.82		
80	1	216		20.12	20.07	19.85	20.79	20.90	20.33	23.48	23.52	23.11		
80	217	0		20.94	20.83	20.68	21.35	21.82	21.17	24.16	24.36	23.94		
80	1	1	16-QAM	22.37	21.88	21.97	22.45	23.09	22.58	25.42	25.54	25.30	22.74	0.1879
80	1	1	64-QAM	21.02	20.36	20.61	21.08	21.50	21.04	24.06	23.98	23.84		
80	1	1	256-QAM	17.81	17.40	17.56	18.07	18.29	18.04	20.95	20.88	20.82		
Limit	EIRP < 1W			Result									Pass	



Part270 NR n77 Maximum Average Power [dBm], DG = -2.8 dBi														
BW	RB	RB	Mod	Antenna 6			Antenna 1			Combine			EIRP	EIRP
(MHz)	Size	Offset		Lowest	Middle	Highest	Lowest	Middle	Highest	Lowest	Middle	Highest	(dBm)	(W)
90	1	1	QPSK	22.90	22.57	22.22	23.03	23.35	23.35	25.98	25.99	25.83	23.19	0.2084
90	1	243		22.10	22.01	21.92	22.68	22.97	22.33	25.41	25.53	25.14		
90	123	61		22.55	22.35	22.23	22.98	23.47	22.90	25.78	25.96	25.59		
90	1	0		20.85	20.48	20.31	21.08	21.34	21.35	23.98	23.94	23.87		
90	1	244		19.86	20.17	19.85	20.73	20.91	20.16	23.33	23.57	23.02		
90	245	0		21.01	20.81	20.61	21.49	21.93	21.33	24.27	24.42	24.00		
90	1	1	16-QAM	22.51	22.09	21.72	22.53	22.76	22.81	25.53	25.45	25.31	22.73	0.1875
90	1	1	64-QAM	20.97	20.61	20.38	21.01	21.37	21.28	24.00	24.02	23.86		
90	1	1	256-QAM	18.01	17.50	17.27	18.14	18.63	18.54	21.09	21.11	20.96		
Limit	EIRP < 1W			Result									Pass	

Part270 NR n77 Maximum Average Power [dBm], DG = -2.8 dBi														
BW	RB	RB	Mod	Antenna 6			Antenna 1			Combine			EIRP	EIRP
(MHz)	Size	Offset		Lowest	Middle	Highest	Lowest	Middle	Highest	Lowest	Middle	Highest	(dBm)	(W)
100	1	1	QPSK	22.50	22.15	21.96	22.73	22.99	23.14	25.63	25.60	25.60	23.18	0.208
100	1	271		22.40	22.41	22.30	23.46	23.46	23.09	25.97	25.98	25.72		
100	137	68		22.42	22.30	22.21	23.08	23.39	23.06	25.77	25.89	25.67		
100	1	0		20.63	20.19	20.07	20.76	20.94	21.14	23.71	23.59	23.65		
100	1	272		20.61	20.46	20.52	21.36	21.44	21.00	24.01	23.99	23.78		
100	273	0		20.90	20.77	20.61	21.59	21.85	21.50	24.27	24.35	24.09		
100	1	1	16-QAM	21.97	21.57	21.44	22.26	22.38	22.68	25.13	25.00	25.11	22.33	0.1710
100	1	1	64-QAM	20.71	20.07	20.05	20.62	20.86	20.90	23.68	23.49	23.51		
100	1	1	256-QAM	17.34	17.05	17.23	14.73	18.06	18.20	19.24	20.59	20.75		
Limit	EIRP < 1W			Result									Pass	



FR1 n77

<SISO Mode>

Peak-to-Average Ratio

Mode	FR1 n77 / 20MHz / DFT-S OFDM				
Mod.	PI/2 BPSK	QPSK	16QAM	64QAM	Limit: 13dB
RB Size	Full RB	Full RB	Full RB	Full RB	Result
Middle CH	4.74	5.90	5.94	6.08	PASS
Mode	FR1 n77 / 20MHz / DFT-S OFDM				
Mod.	256QAM				Limit: 13dB
RB Size	Full RB				Result
Middle CH	6.82				PASS



FR1 n77 / 20MHz / DFT-S OFDM / Middle Channel / Full RB

PI/2 BPSK

QPSK

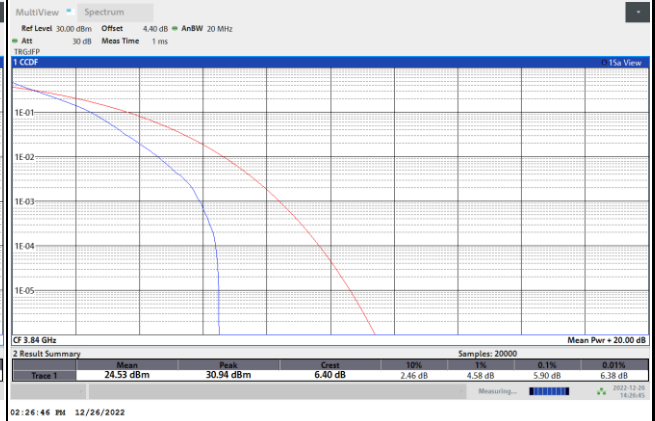
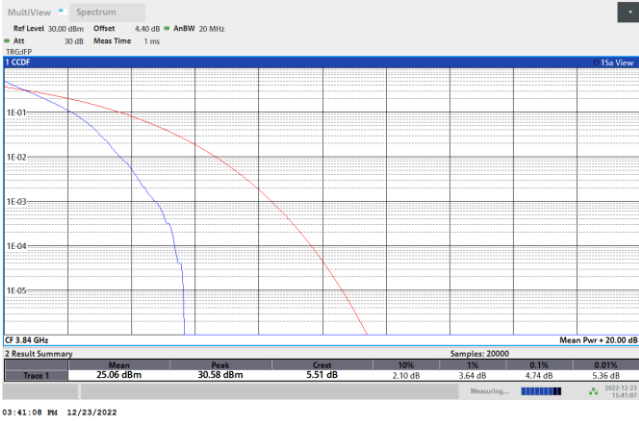

16QAM

64QAM

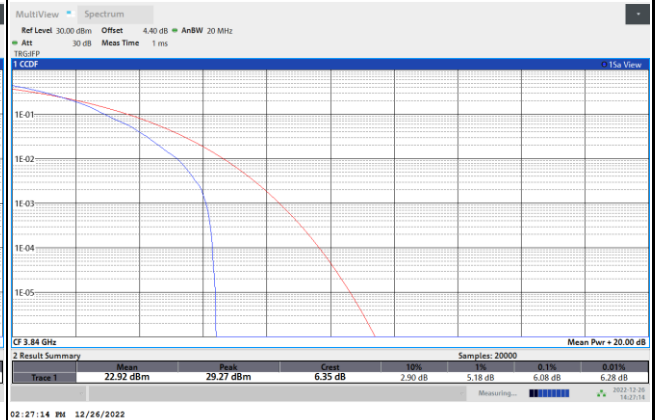
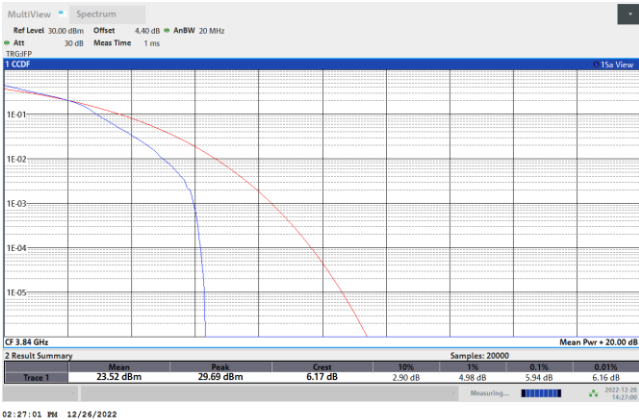

256QAM

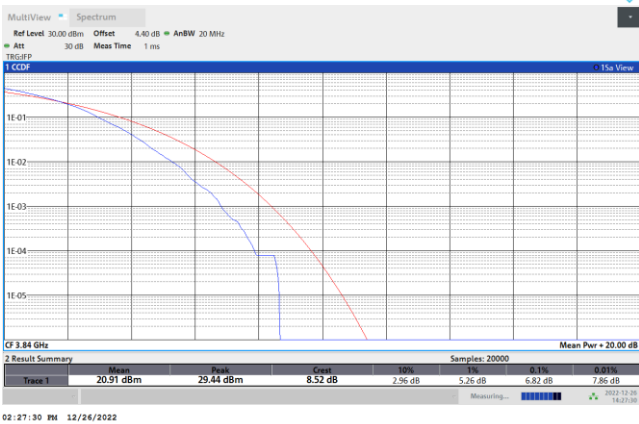



26dB Bandwidth

Mode	FR1 n77 : 26dB BW(MHz) / DFT-S OFDM							
BW	10MHz	15MHz	20MHz	25MHz	30MHz	40MHz	50MHz	60MHz
Mod.	PI/2 BPSK	PI/2 BPSK	PI/2 BPSK	PI/2 BPSK	PI/2 BPSK	PI/2 BPSK	PI/2 BPSK	PI/2 BPSK
Middle CH	9.33	13.91	18.78	23.78	27.69	38.36	48.65	60.78
BW	70MHz	80MHz	90MHz	100MHz				
Mod.	PI/2 BPSK	PI/2 BPSK	PI/2 BPSK	PI/2 BPSK				
Middle CH	67.55	80.24	89.91	100.10				

Mode	FR1 n77 : 26dB BW(MHz) / CP OFDM							
BW	10MHz		15MHz		20MHz		25MHz	
Mod.	QPSK	16QAM	QPSK	16QAM	QPSK	16QAM	QPSK	16QAM
Middle CH	9.09	9.35	14.66	14.42	19.30	19.02	24.38	24.53
Mod.	64QAM	256QAM	64QAM	256QAM	64QAM	256QAM	64QAM	256QAM
Middle CH	9.13	9.01	14.36	14.69	19.14	19.26	24.23	24.33
BW	30MHz		40MHz		50MHz		60MHz	
Mod.	QPSK	16QAM	QPSK	16QAM	QPSK	16QAM	QPSK	16QAM
Middle CH	28.77	29.07	40.36	40.36	50.15	50.15	60.90	60.66
Mod.	64QAM	256QAM	64QAM	256QAM	64QAM	256QAM	64QAM	256QAM
Middle CH	29.01	28.95	40.52	40.68	50.25	50.45	60.54	60.66
BW	70MHz		80MHz		90MHz		100MHz	
Mod.	QPSK	16QAM	QPSK	16QAM	QPSK	16QAM	QPSK	16QAM
Middle CH	71.05	70.49	80.56	80.24	90.63	90.63	100.50	100.70
Mod.	64QAM	256QAM	64QAM	256QAM	64QAM	256QAM	64QAM	256QAM
Middle CH	70.49	70.63	80.40	80.24	90.99	90.81	100.90	100.50



FR1 n77 / 10MHz / DFT-S OFDM / Middle Channel / Full RB

PI/2 BPSK

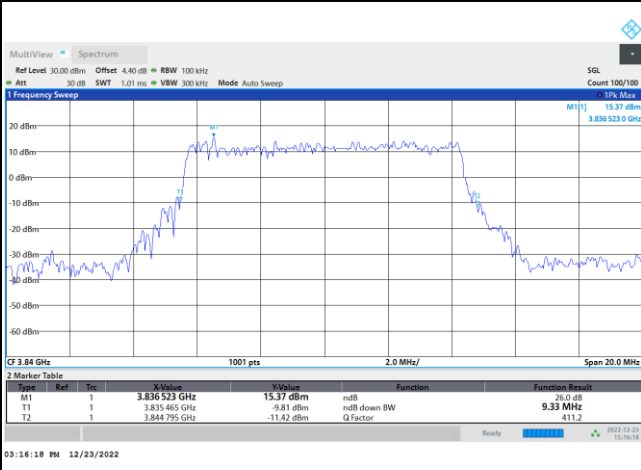

FR1 n77 / 10MHz / CP OFDM / Middle Channel / Full RB

QPSK

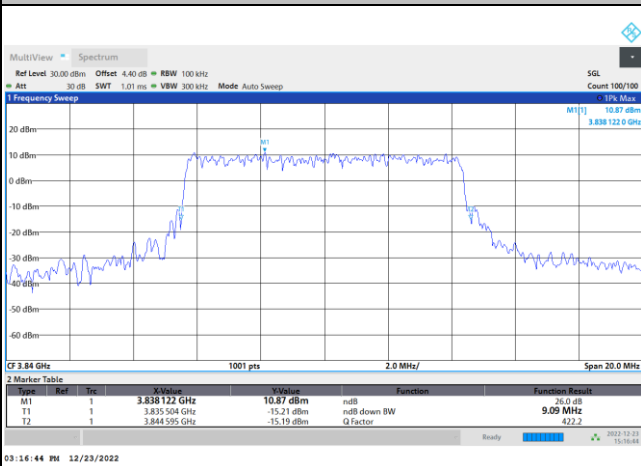

16QAM

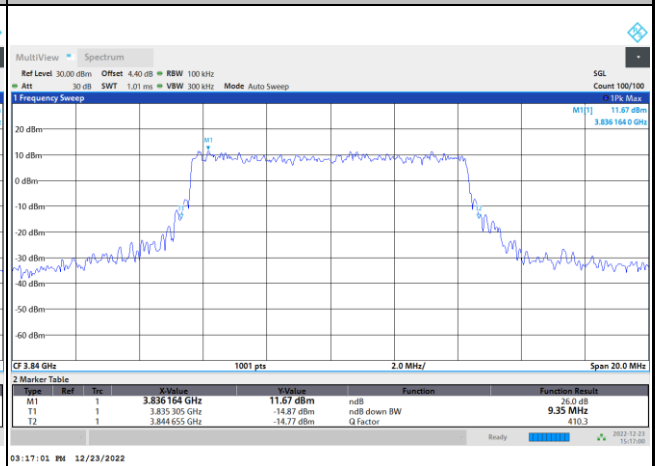

64QAM

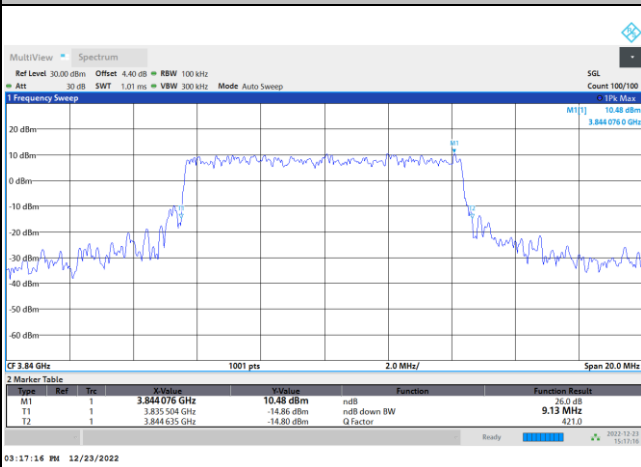

256QAM

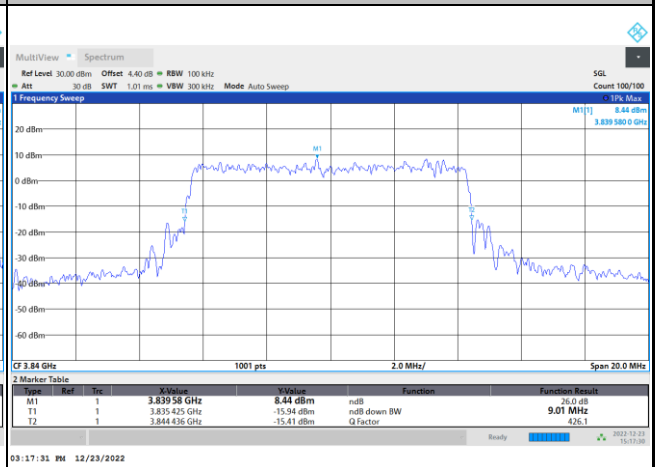



FR1 n77 / 15MHz / DFT-S OFDM / Middle Channel / Full RB

PI/2 BPSK

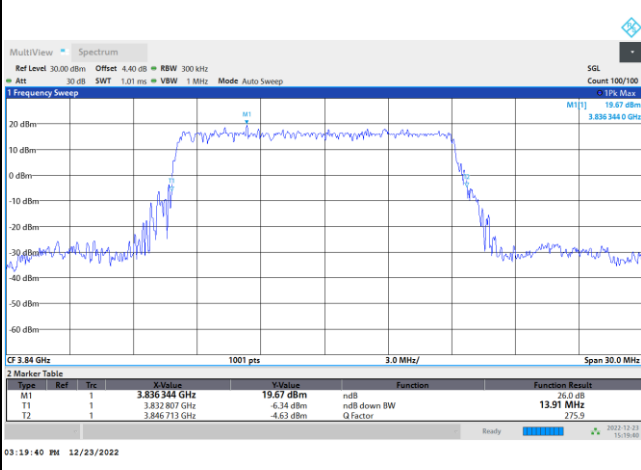

FR1 n77 / 15MHz / CP OFDM / Middle Channel / Full RB

QPSK

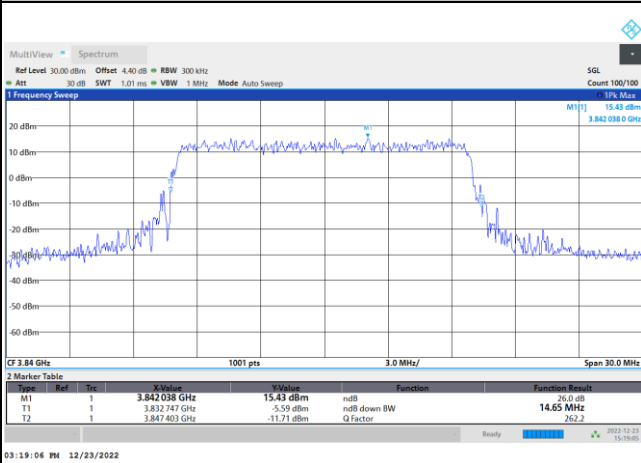

16QAM

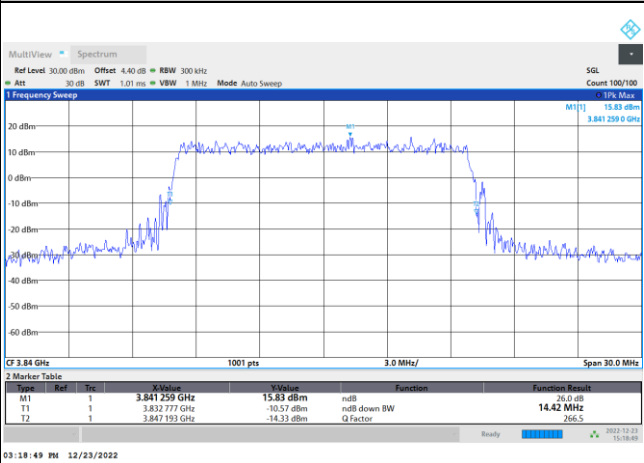

64QAM

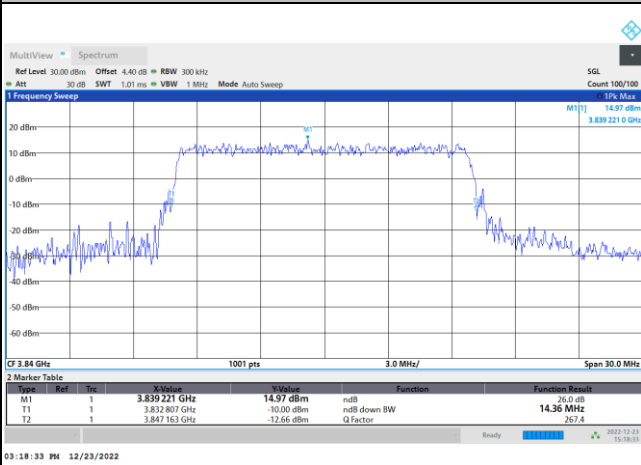

256QAM

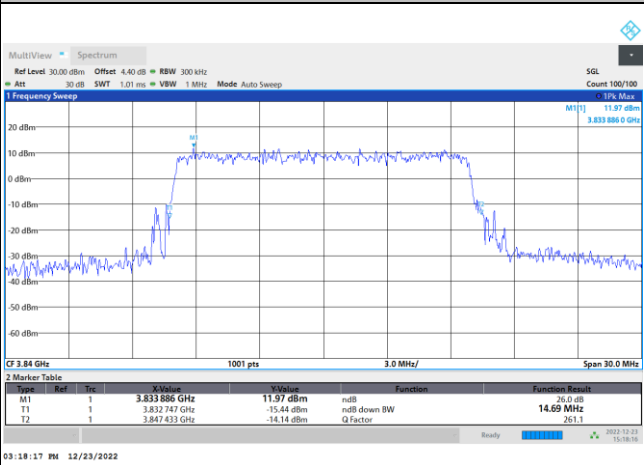



FR1 n77 / 20MHz / DFT-S OFDM / Middle Channel / Full RB

PI/2 BPSK

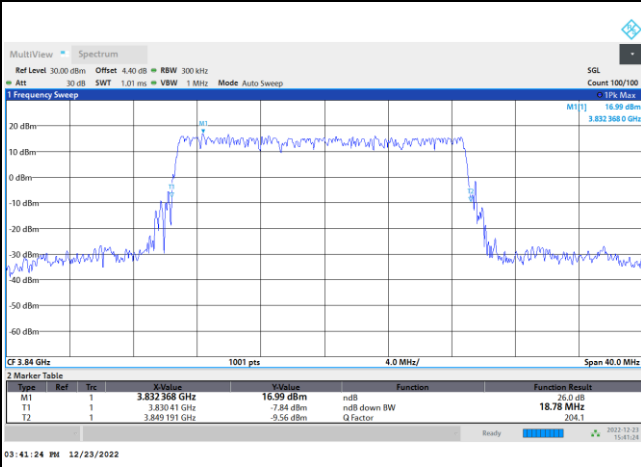

FR1 n77 / 20MHz / CP OFDM / Middle Channel / Full RB

QPSK

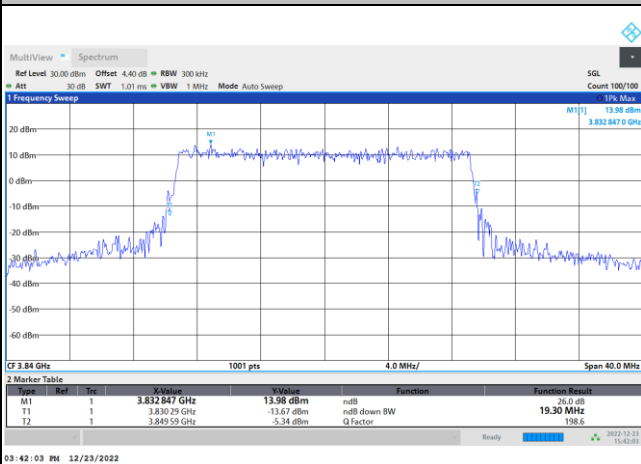

16QAM

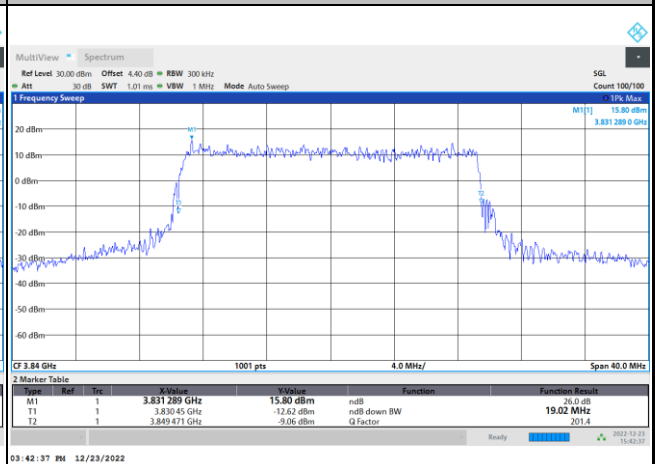

64QAM

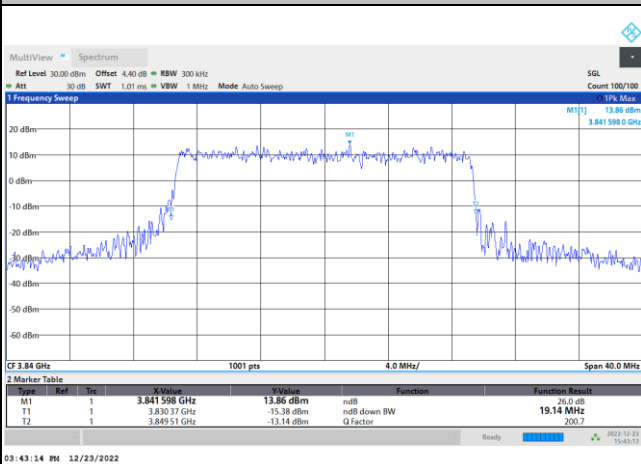

256QAM

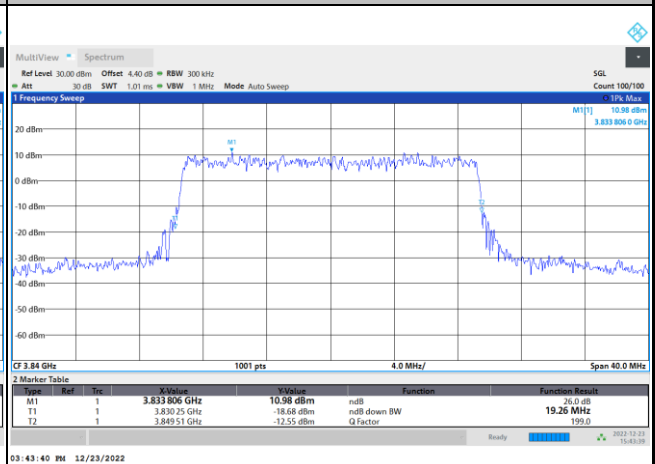



FR1 n77 / 25MHz / DFT-S OFDM / Middle Channel / Full RB

PI/2 BPSK

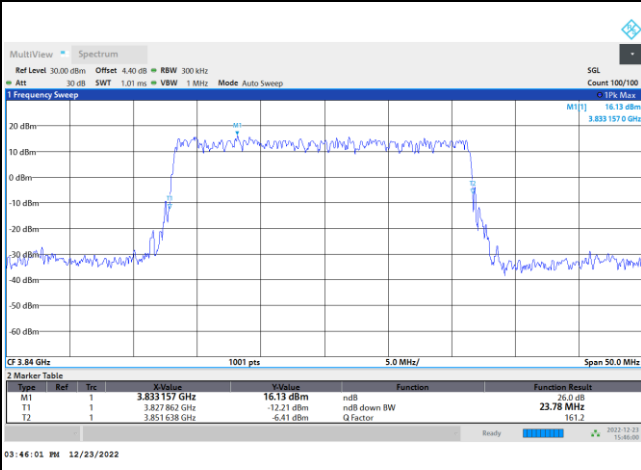

FR1 n77 / 25MHz / CP OFDM / Middle Channel / Full RB

QPSK

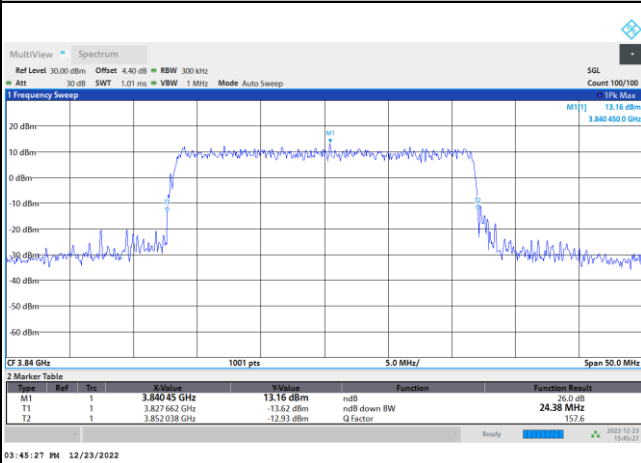

16QAM

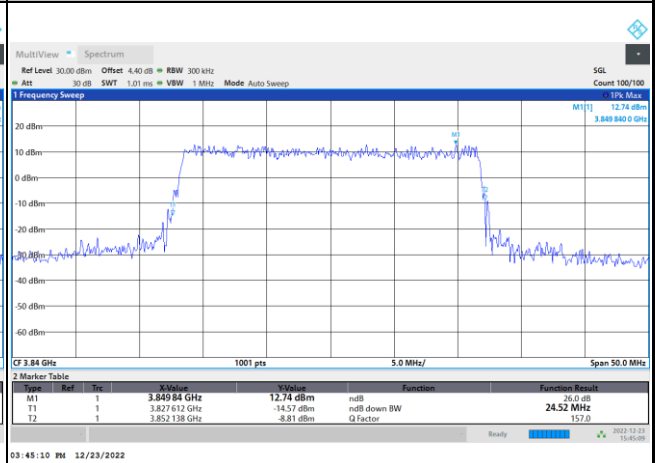

64QAM

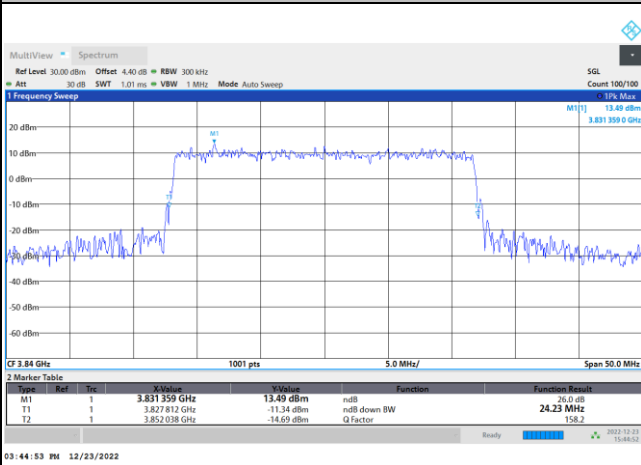

256QAM

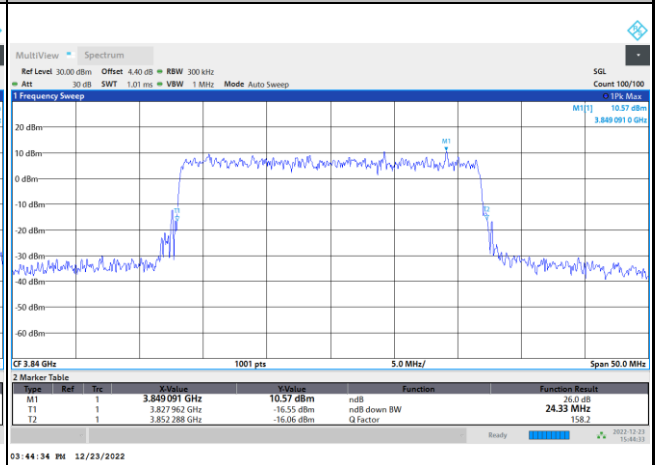



FR1 n77 / 30MHz / DFT-S OFDM / Middle Channel / Full RB

PI/2 BPSK

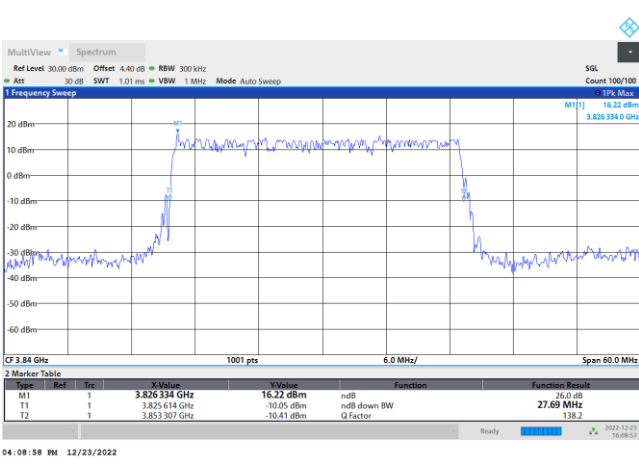

FR1 n77 / 30MHz / CP OFDM / Middle Channel / Full RB

QPSK

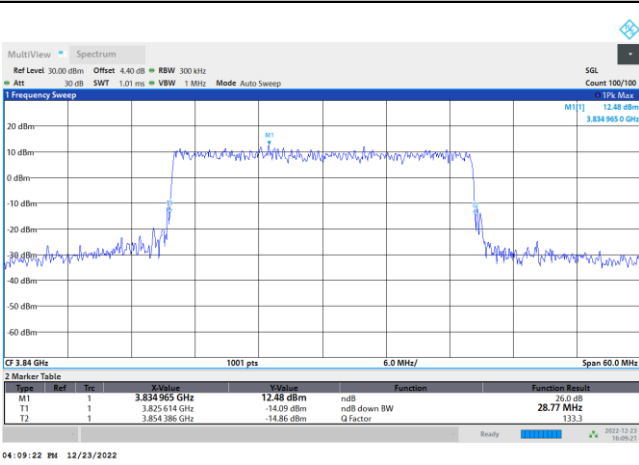

16QAM

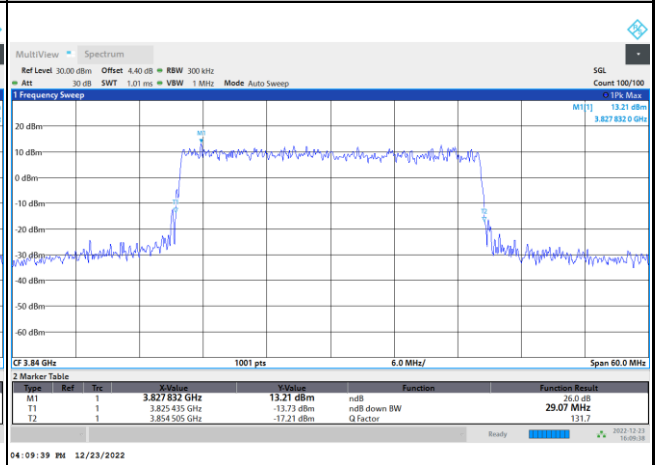

64QAM

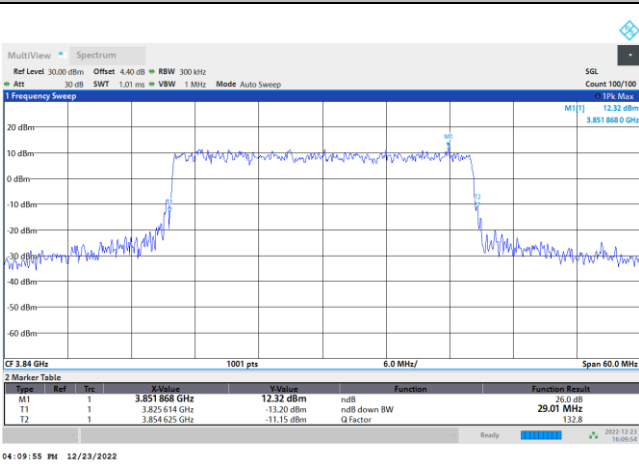

256QAM

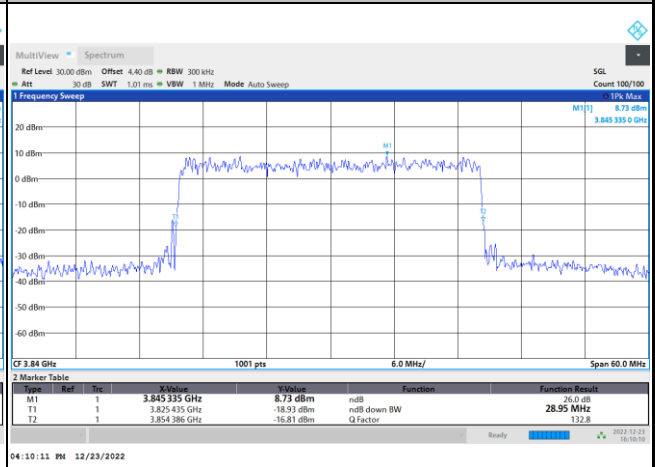



FR1 n77 / 40MHz / DFT-S OFDM / Middle Channel / Full RB

PI/2 BPSK

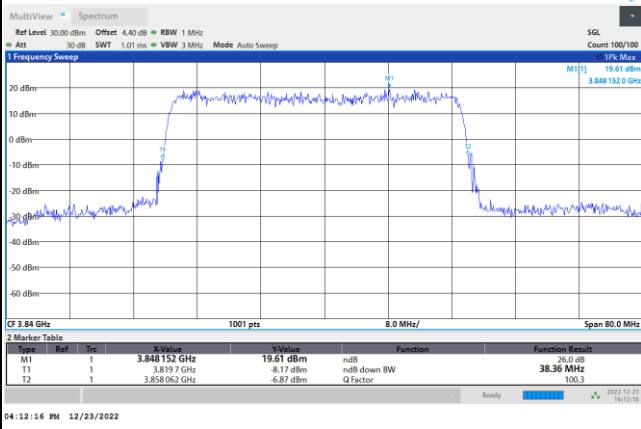

FR1 n77 / 40MHz / CP OFDM / Middle Channel / Full RB

QPSK

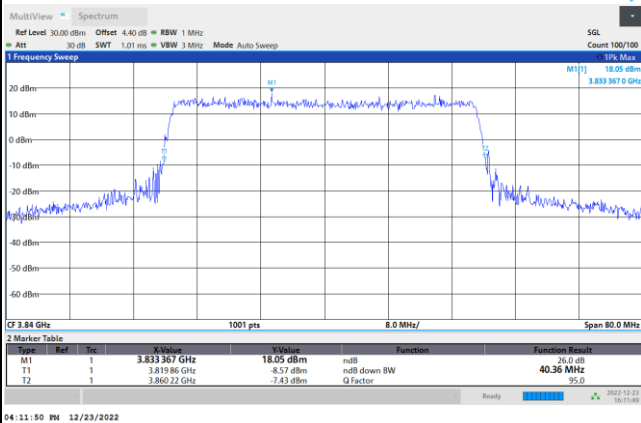

16QAM

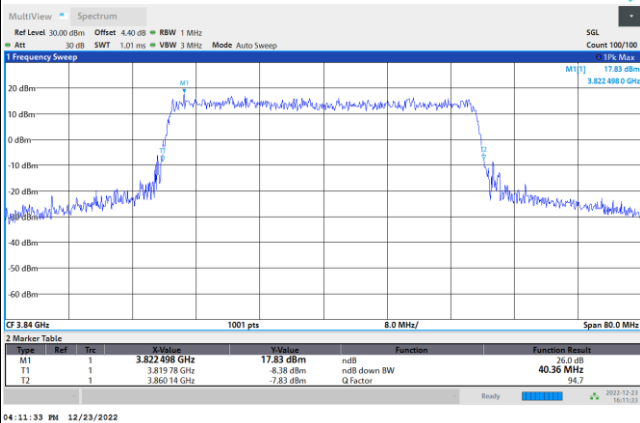

64QAM

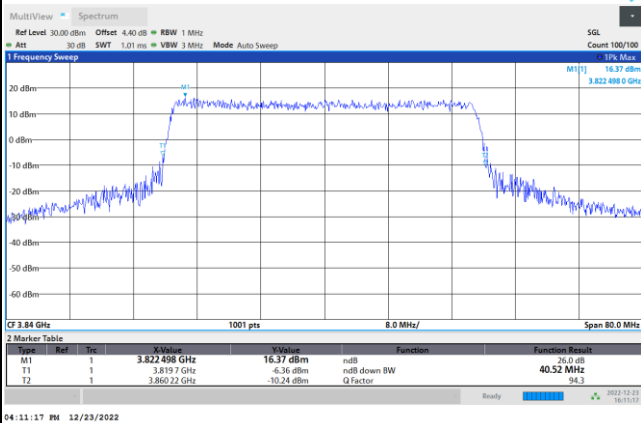

256QAM

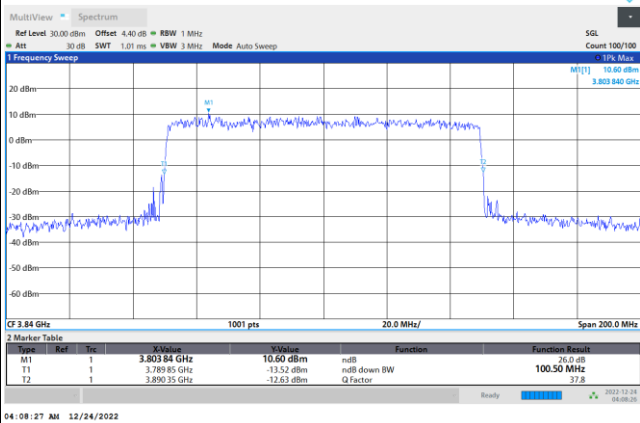



FR1 n77 / 50MHz / DFT-S OFDM / Middle Channel / Full RB

PI/2 BPSK

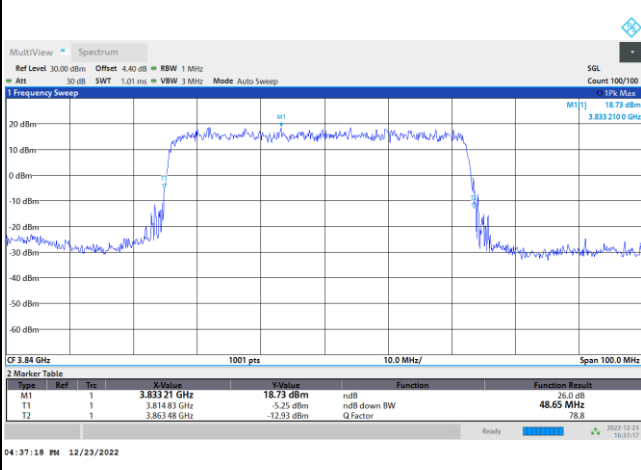

FR1 n77 / 50MHz / CP OFDM / Middle Channel / Full RB

QPSK

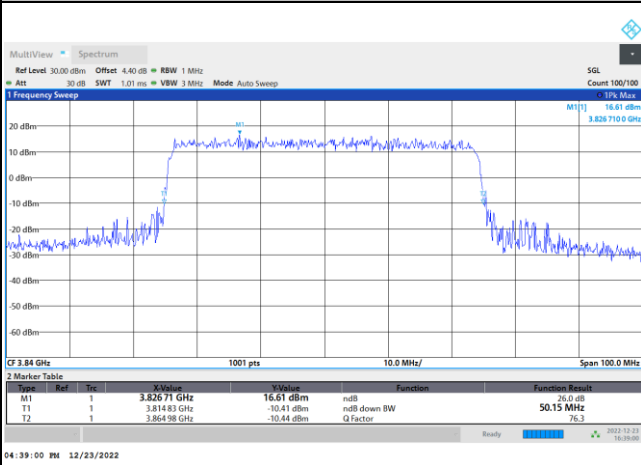

16QAM

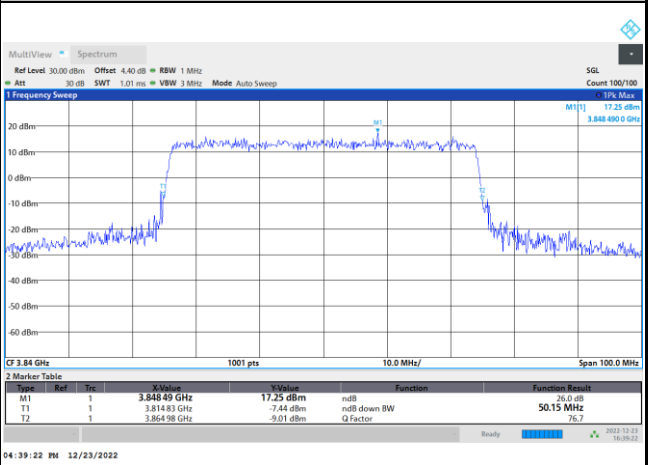

64QAM

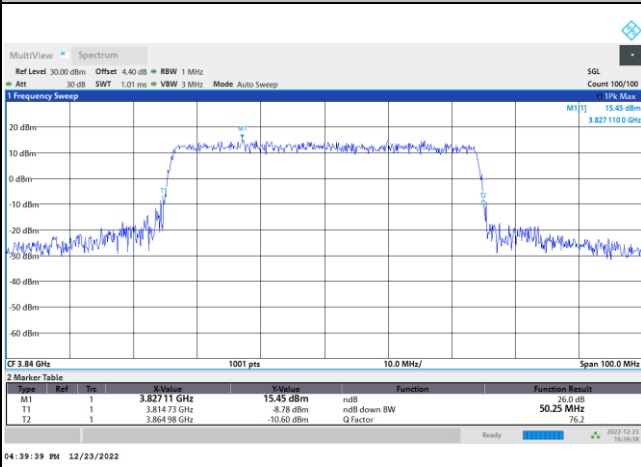

256QAM

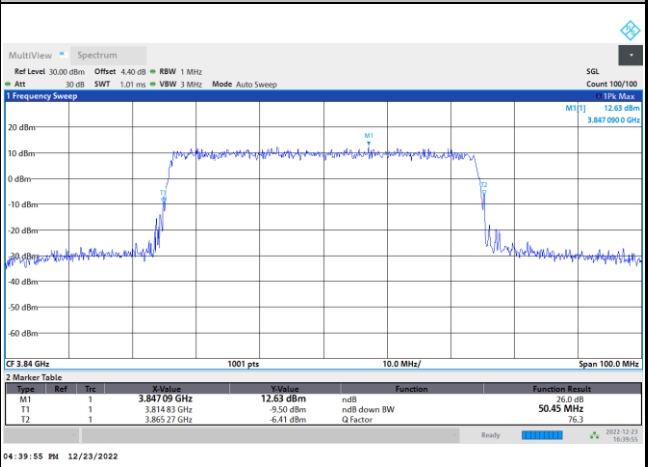



FR1 n77 / 60MHz / DFT-S OFDM / Middle Channel / Full RB

PI/2 BPSK

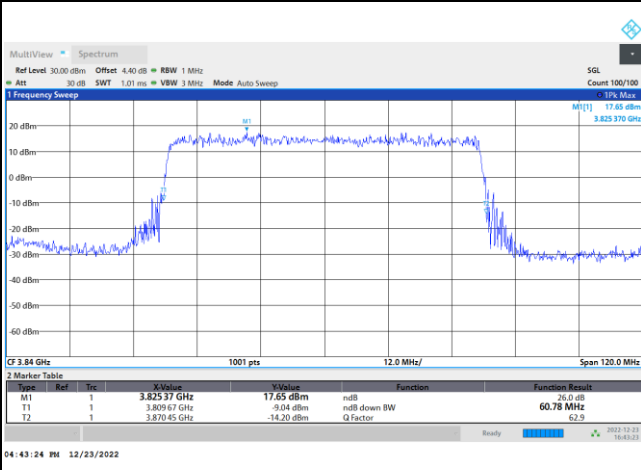

FR1 n77 / 60MHz / CP OFDM / Middle Channel / Full RB

QPSK

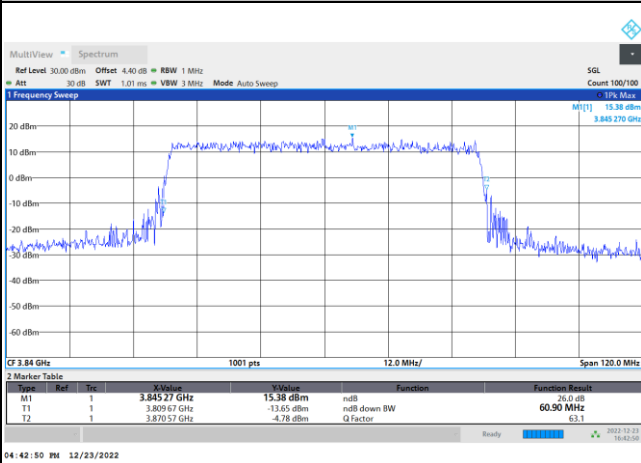

16QAM

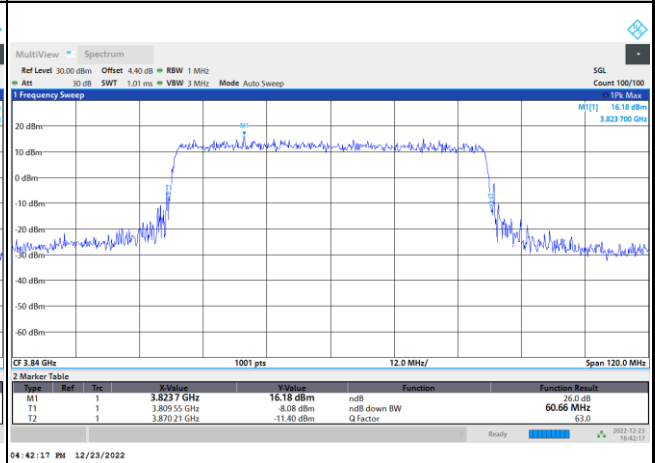

64QAM

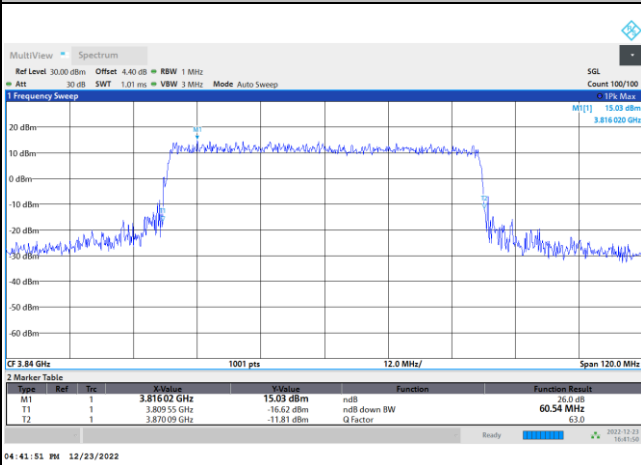

256QAM

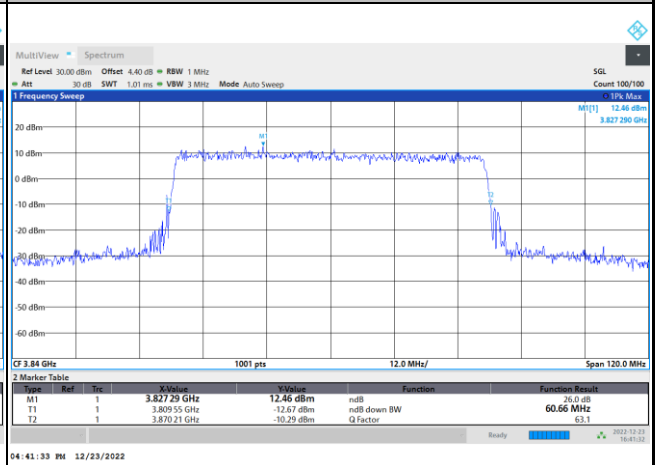



FR1 n77 / 70MHz / DFT-S OFDM / Middle Channel / Full RB

PI/2 BPSK

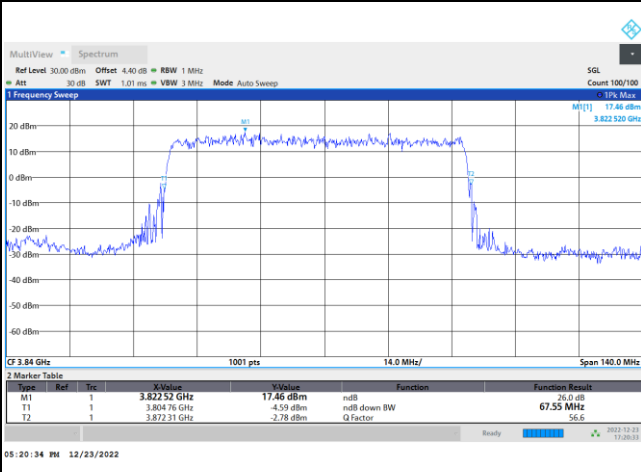

FR1 n77 / 70MHz / CP OFDM / Middle Channel / Full RB

QPSK

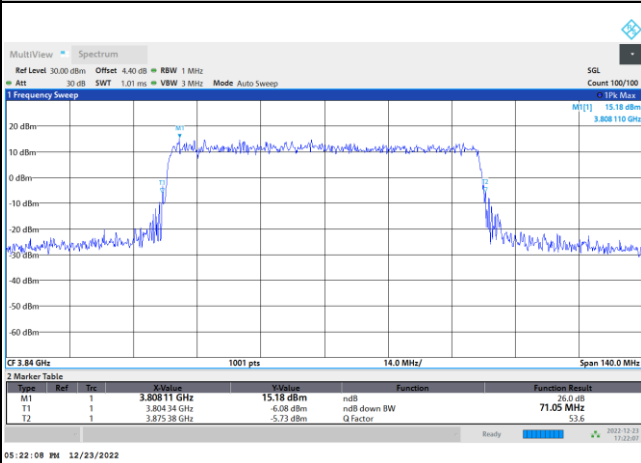

16QAM

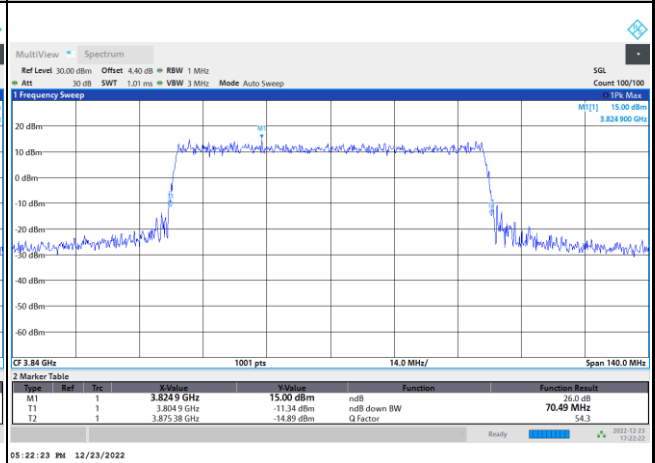

64QAM

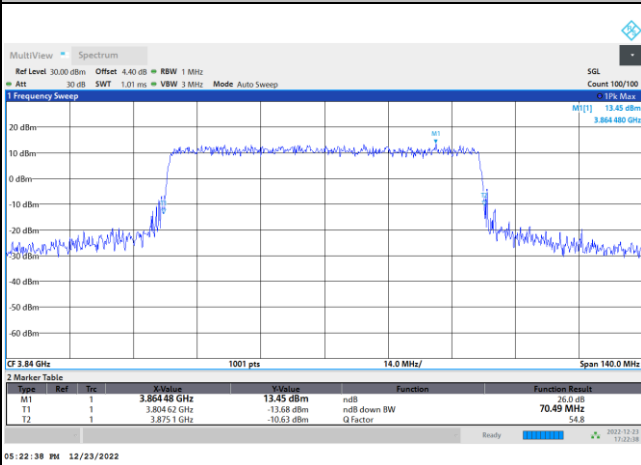

256QAM

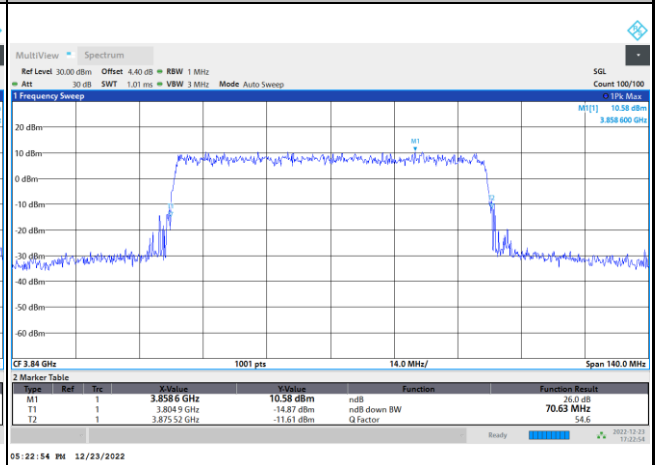



FR1 n77 / 80MHz / DFT-S OFDM / Middle Channel / Full RB

PI/2 BPSK

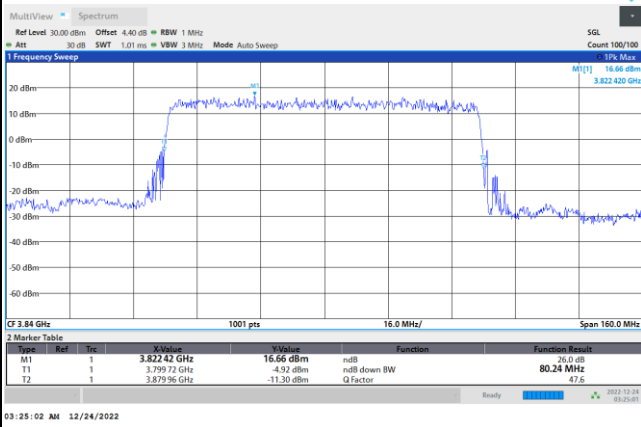

FR1 n77 / 80MHz / CP OFDM / Middle Channel / Full RB

QPSK

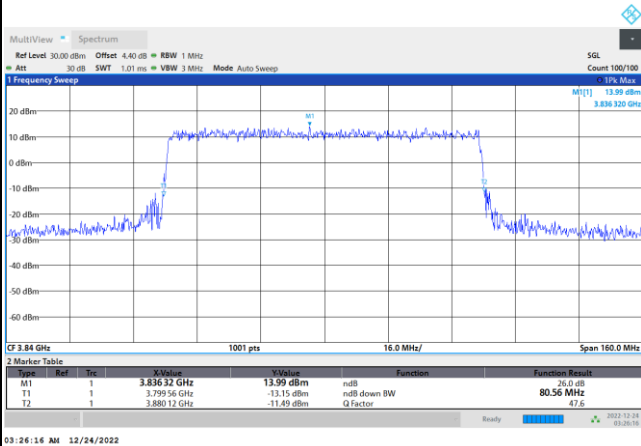

16QAM

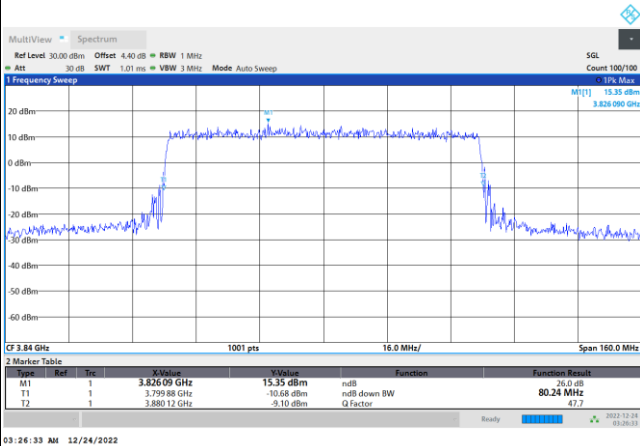

64QAM

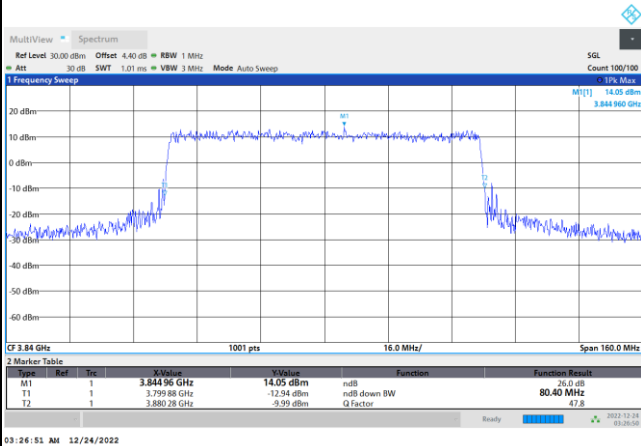

256QAM

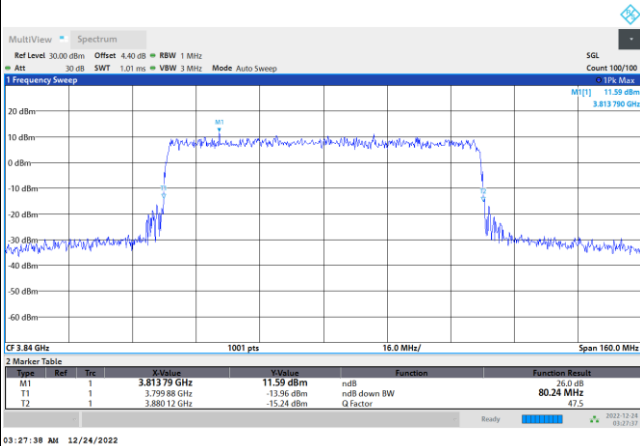



FR1 n77 / 90MHz / DFT-S OFDM / Middle Channel / Full RB

PI/2 BPSK

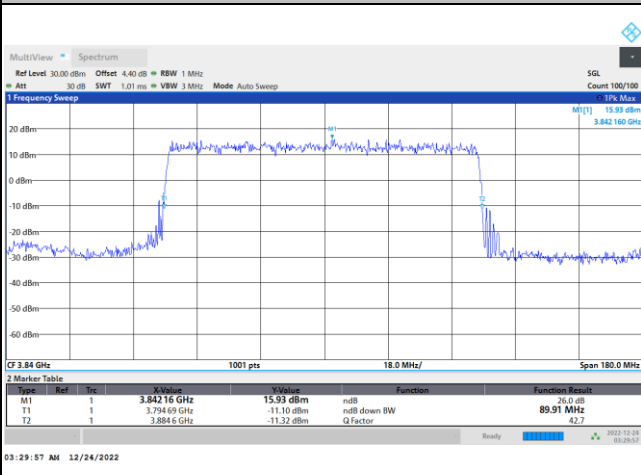

FR1 n77 / 90MHz / CP OFDM / Middle Channel / Full RB

QPSK

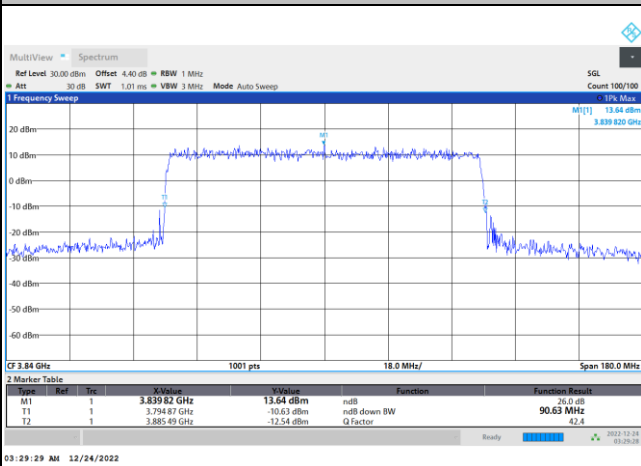

16QAM

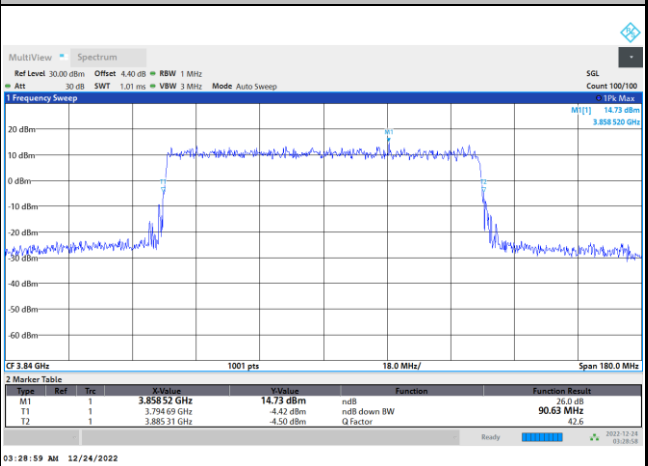

64QAM

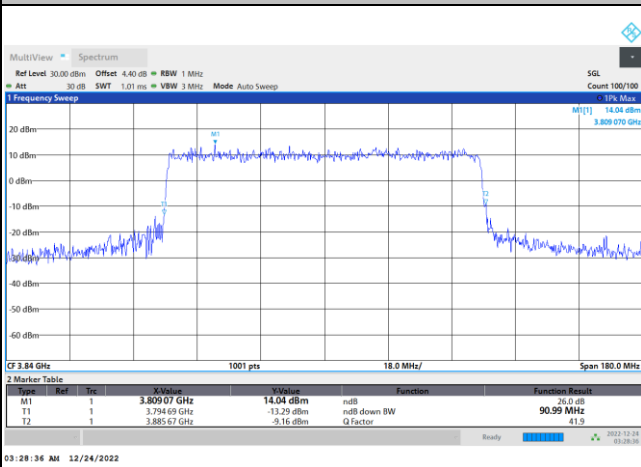

256QAM

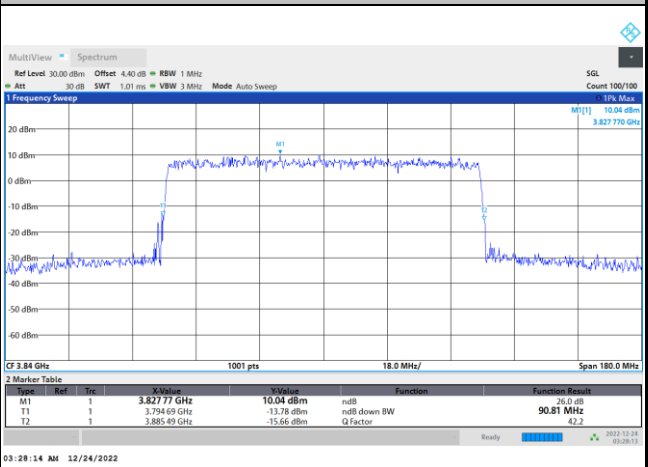



FR1 n77 / 100MHz / DFT-S OFDM / Middle Channel / Full RB

PI/2 BPSK

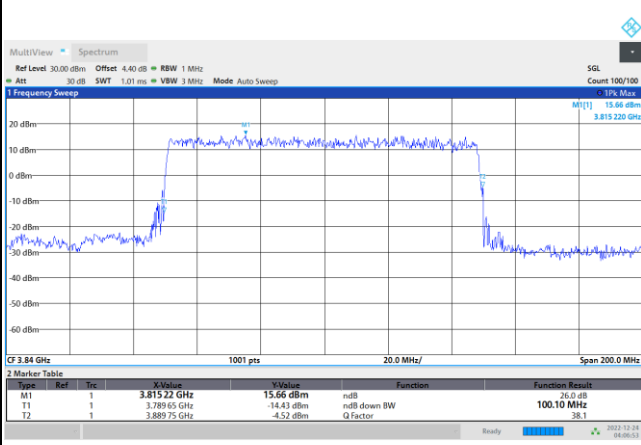

FR1 n77 / 100MHz / CP OFDM / Middle Channel / Full RB

QPSK

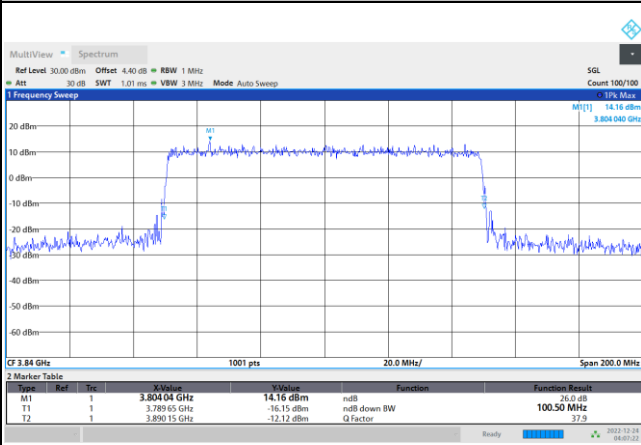

16QAM

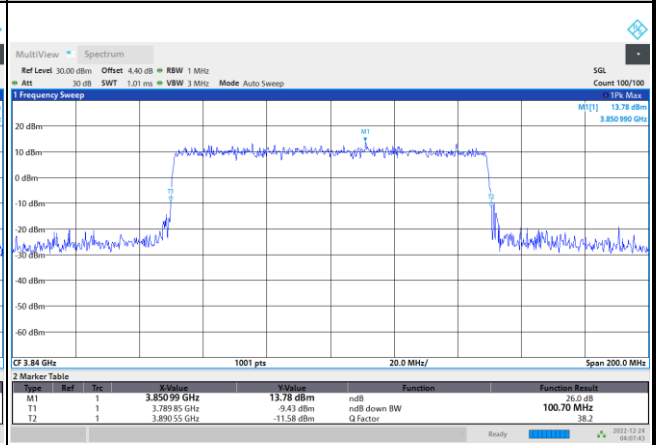

64QAM

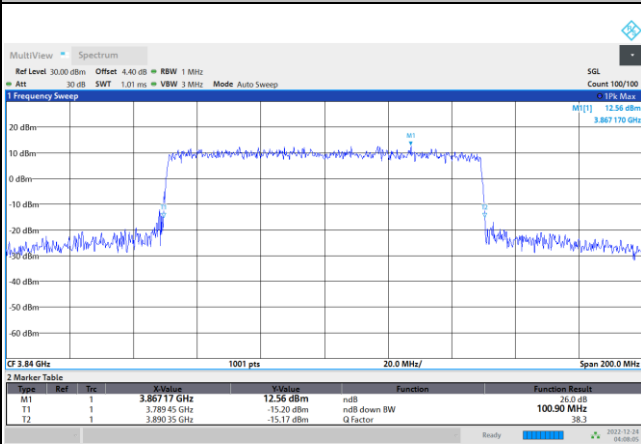

256QAM

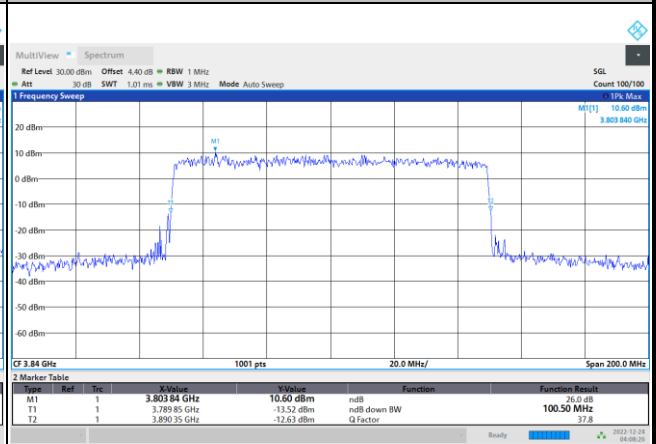



Occupied Bandwidth

Mode	FR1 n77 : OB BW(MHz) / DFT-S OFDM							
BW	10MHz	15MHz	20MHz	25MHz	30MHz	40MHz	50MHz	60MHz
Mod.	PI/2 BPSK	PI/2 BPSK	PI/2 BPSK	PI/2 BPSK	PI/2 BPSK	PI/2 BPSK	PI/2 BPSK	PI/2 BPSK
Middle CH	8.59	12.94	17.91	22.86	26.74	36.10	45.90	58.02
BW	70MHz	80MHz	90MHz	100MHz				
Mod.	PI/2 BPSK	PI/2 BPSK	PI/2 BPSK	PI/2 BPSK				
Middle CH	64.35	76.88	86.70	96.07				

Mode	FR1 n77 : OB BW(MHz) / CP OFDM							
BW	10MHz		15MHz		20MHz		25MHz	
Mod.	QPSK	16QAM	QPSK	16QAM	QPSK	16QAM	QPSK	16QAM
Middle CH	8.60	8.60	13.61	13.68	18.22	18.25	23.16	23.25
Mod.	64QAM	256QAM	64QAM	256QAM	64QAM	256QAM	64QAM	256QAM
Middle CH	8.59	8.56	13.58	13.64	18.25	18.23	23.28	23.25
BW	30MHz		40MHz		50MHz		60MHz	
Mod.	QPSK	16QAM	QPSK	16QAM	QPSK	16QAM	QPSK	16QAM
Middle CH	27.81	27.89	38.16	38.18	47.47	47.50	57.69	57.79
Mod.	64QAM	256QAM	64QAM	256QAM	64QAM	256QAM	64QAM	256QAM
Middle CH	27.79	27.78	38.09	38.11	47.79	47.61	57.77	57.83
BW	70MHz		80MHz		90MHz		100MHz	
Mod.	QPSK	16QAM	QPSK	16QAM	QPSK	16QAM	QPSK	16QAM
Middle CH	67.37	67.43	77.42	77.39	87.15	87.31	97.11	97.18
Mod.	64QAM	256QAM	64QAM	256QAM	64QAM	256QAM	64QAM	256QAM
Middle CH	67.45	67.47	77.43	77.31	87.33	87.29	97.29	97.31



FR1 n77 / 10MHz / DFT-S OFDM / Middle Channel / Full RB

PI/2 BPSK

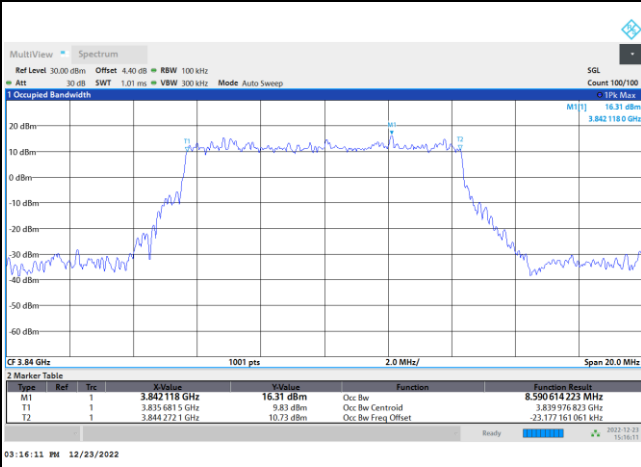

FR1 n77 / 10MHz / CP OFDM / Middle Channel / Full RB

QPSK

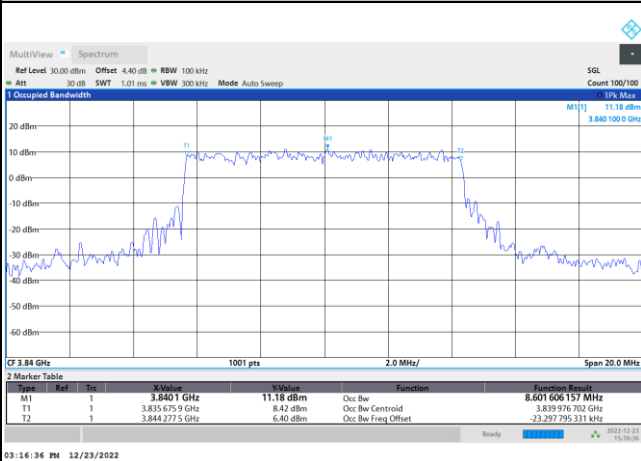

16QAM

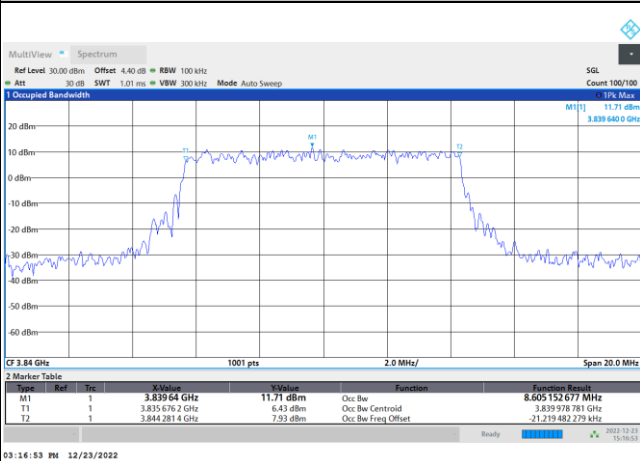

64QAM

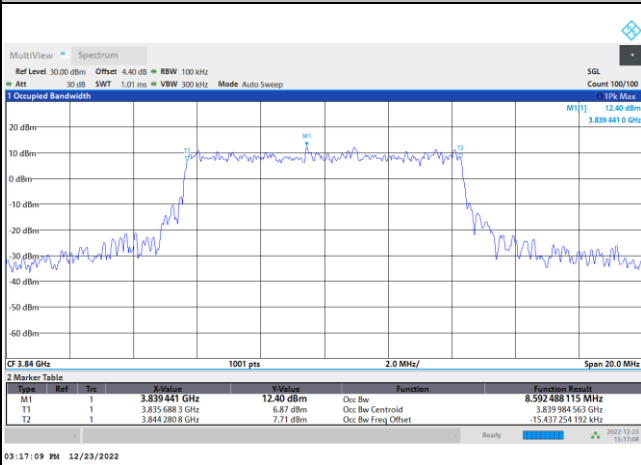

256QAM

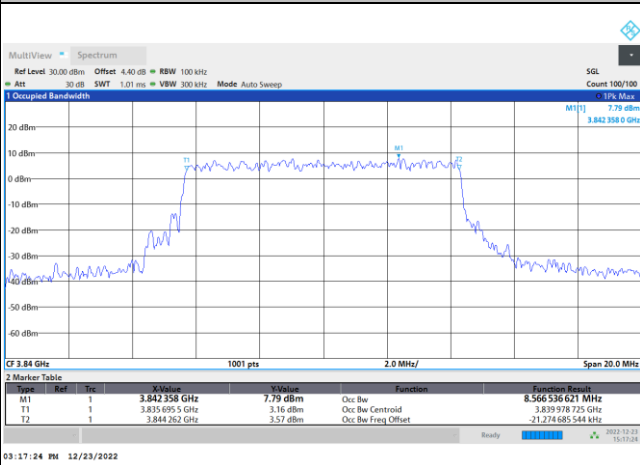



FR1 n77 / 15MHz / DFT-S OFDM / Middle Channel / Full RB

PI/2 BPSK

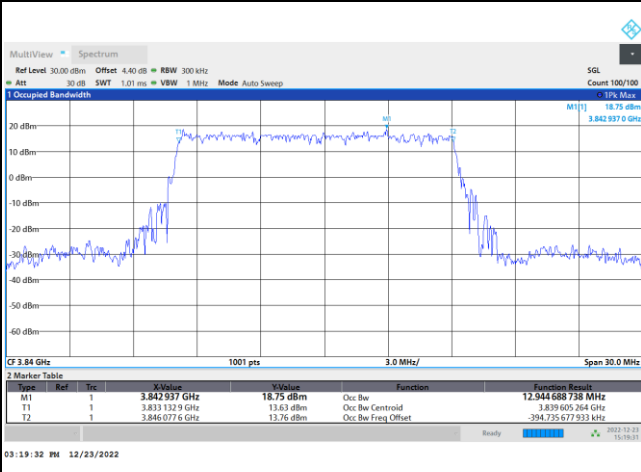

FR1 n77 / 15MHz / CP OFDM / Middle Channel / Full RB

QPSK

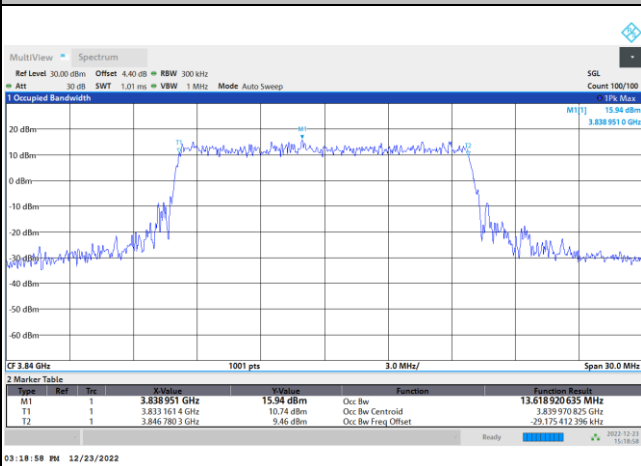

16QAM

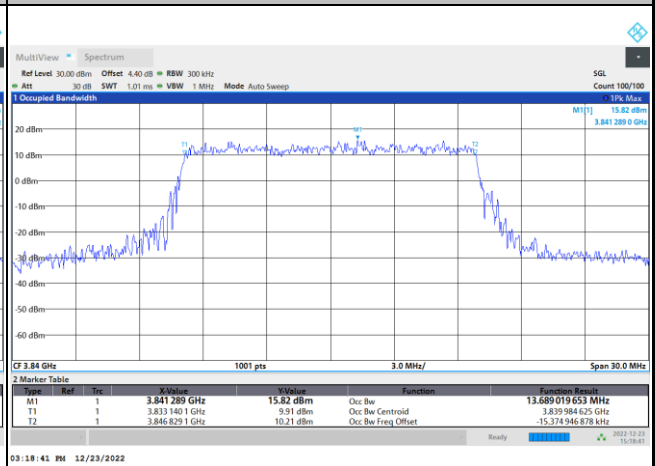

64QAM

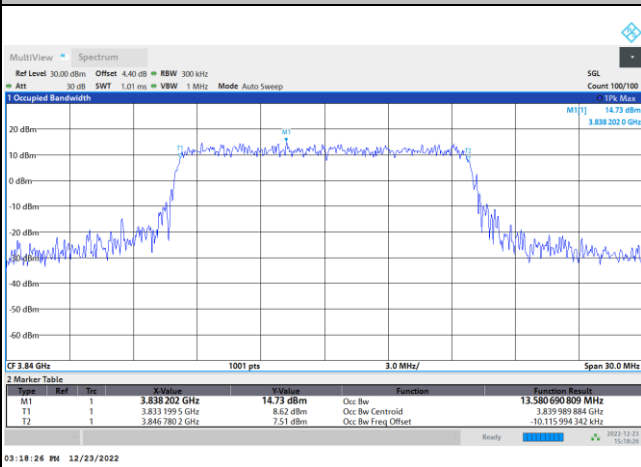

256QAM

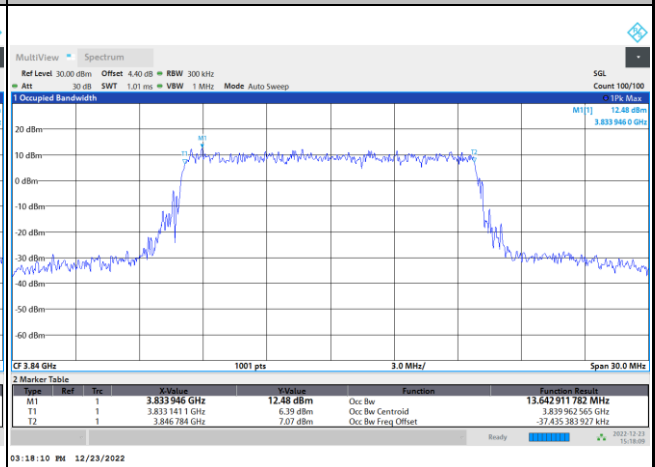



FR1 n77 / 20MHz / DFT-S OFDM / Middle Channel / Full RB

PI/2 BPSK

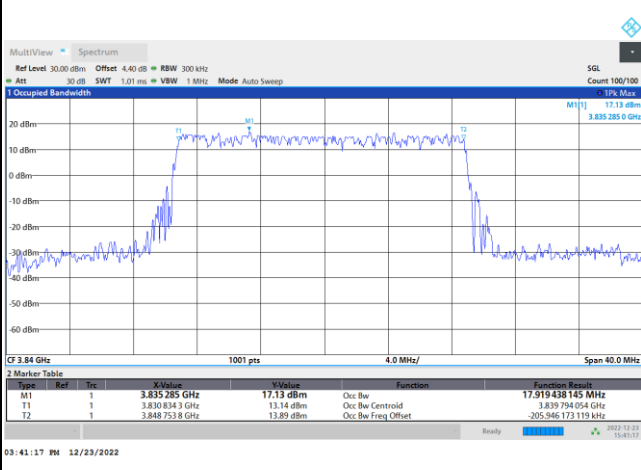

FR1 n77 / 20MHz / CP OFDM / Middle Channel / Full RB

QPSK

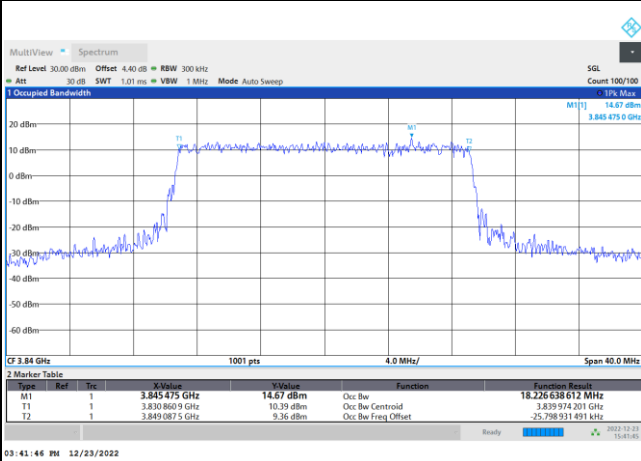

16QAM

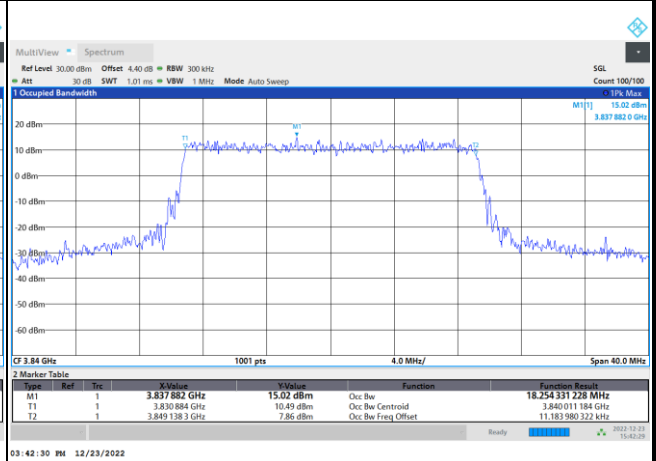

64QAM

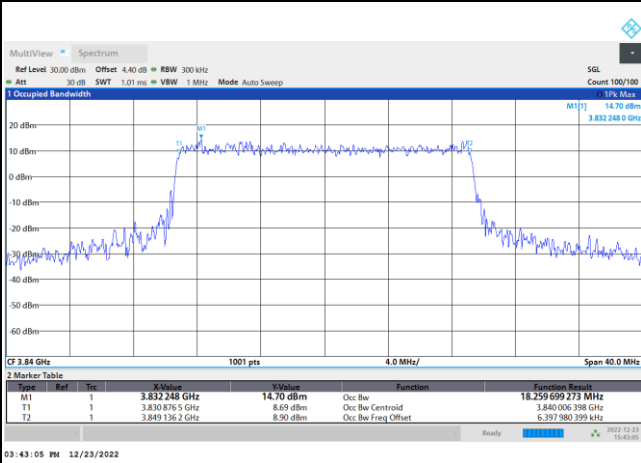

256QAM

