



FCC RADIO TEST REPORT

FCC ID : A4RG9FPL
Equipment : Phone
Model Name : G9FPL, G0B96
Applicant : Google LLC
1600 Amphitheatre Parkway,
Mountain View, California, 94043 USA
Standard : FCC 47 CFR Part 2, 22(H), 24(E), 27, 90(R), 90(S)

The product was received on Nov. 23, 2022 and testing was performed from Nov. 25, 2022 to Jan. 18, 2023. We, Sporton International Inc. EMC & Wireless Communications Laboratory, would like to declare that the tested sample has been evaluated in accordance with the test procedures given in ANSI / TIA-603-E and has been in compliance with the applicable technical standards.

The test results in this report apply exclusively to the tested model / sample. Without written approval from Sporton International Inc. EMC & Wireless Communications Laboratory, the test report shall not be reproduced except in full.

Louis Wu

Approved by: Louis Wu

Sporton International Inc. EMC & Wireless Communications Laboratory

No. 52, Huaya 1st Rd., Guishan Dist., Taoyuan City 333, Taiwan (R.O.C.)



Table of Contents

| | |
|--|-----------|
| History of this test report..... | 3 |
| Summary of Test Result..... | 4 |
| 1 General Description | 6 |
| 1.1 Product Feature of Equipment Under Test..... | 6 |
| 1.2 Product Specification of Equipment Under Test..... | 7 |
| 1.3 Modification of EUT | 10 |
| 1.4 Testing Location | 11 |
| 1.5 Applicable Standards..... | 11 |
| 2 Test Configuration of Equipment Under Test | 12 |
| 2.1 Test Mode..... | 12 |
| 2.2 Connection Diagram of Test System..... | 19 |
| 2.3 Support Unit used in test configuration and system | 19 |
| 2.4 Measurement Results Explanation Example..... | 19 |
| 2.5 Frequency List of Low/Middle/High Channels | 20 |
| 3 Conducted Test Items..... | 34 |
| 3.1 Measuring Instruments | 34 |
| 3.2 Conducted Output Power and ERP/EIRP | 35 |
| 3.3 Peak-to-Average Ratio | 36 |
| 3.4 Occupied Bandwidth..... | 37 |
| 3.5 Conducted Band Edge | 38 |
| 3.6 Emission Mask..... | 41 |
| 3.7 Conducted Spurious Emission | 43 |
| 3.8 Frequency Stability | 44 |
| 4 Radiated Test Items | 45 |
| 4.1 Measuring Instruments | 45 |
| 4.2 Radiated Spurious Emission Measurement | 47 |
| 5 List of Measuring Equipment..... | 49 |
| 6 Uncertainty of Evaluation..... | 51 |
| Appendix A. Test Results of Conducted Test | |
| Appendix B. Test Results of Radiated Test | |
| Appendix C. Test Setup Photographs | |



History of this test report

| Report No. | Version | Description | Issue Date |
|--------------|---------|---|---------------|
| FG262403-04C | 01 | Initial issue of report | Feb. 17, 2023 |
| FG262403-04C | 02 | Revise Summary Remark 2 and Appendix A, B | Mar. 07, 2023 |
| | | | |
| | | | |
| | | | |
| | | | |
| | | | |
| | | | |
| | | | |
| | | | |
| | | | |
| | | | |
| | | | |
| | | | |
| | | | |
| | | | |



Summary of Test Result

| Report Clause | Ref Std. Clause | Test Items | Result (PASS/FAIL) | Remark |
|---------------|---|--|--------------------|--------|
| 3.2 | §2.1046 | Conducted Output Power | Reporting only | - |
| | §22.913 (a)(5) §90.635 | Effective Radiated Power (Band 5) (Band 26) | Pass | |
| | §27.50 (b)(10) §27.50 (c)(10) | Effective Radiated Power (Band 12) (Band 13) (Band 17) (Band 71) | | |
| | §24.232 (c) §27.50 (h)(2) | Equivalent Isotropic Radiated Power (Band 2) (Band 25) (Band 7) (Band 38) (Band 41) | | |
| | §27.50 (d)(4) | Equivalent Isotropic Radiated Power (Band 4) (Band 66) | | |
| | §27.50 (a)(3) | Effective Isotropic Radiated Power (Band 30) | | |
| | §90.542 (a)(7) | Effective Radiated Power (Band 14) | | |
| 3.3 | §24.232 (d) §27.50 (d)(5) | Peak-to-Average Ratio | Pass | - |
| 3.4 | §2.1049 | Occupied Bandwidth | Reporting only | - |
| 3.5 | §2.1051 §22.917 (a) §24.238 (a) §27.53 (c)(2)(4) §27.53 (g) §27.53 (h) | Conducted Band Edge Measurement (Band 2) (Band 4) (Band 5) (Band 12) (Band 13) (Band 17) (Band 25) (Band 26) (Band 66) (Band 71) | Pass | - |
| | §2.1051 §27.53 (m)(4) | Conducted Band Edge Measurement (Band 7) (Band 38) (Band 41) | | |
| | §2.1051 §27.53 (a)(4) | Conducted Band Edge Measurement (Band 30) | | |
| | §2.1051 §90.543 (e)(2) | Conducted Band Edge Measuremen (Band 14) | | |
| 3.6 | §2.1051 §90.210 (n) | Emission Mask (Band 14) | Pass | - |
| | §2.1051 §90.691 | Emission Masks (Band 26) | | |



| Report Clause | Ref Std. Clause | Test Items | Result (PASS/FAIL) | Remark |
|---------------|---|--|--------------------|---|
| 3.7 | §2.1051 §22.917 (a) §24.238 (a) §27.53 (c)(2) §27.53 (g) §27.53 (h) §90.691 | Conducted Spurious Emission (Band 2) (Band 4) (Band 5) (Band 12) (Band 13) (Band 17) (Band 25) (Band 26) (Band 66) (Band 71) | Pass | - |
| | §2.1051 §27.53 (m)(4) | Conducted Spurious Emission (Band 7) (Band 38) (Band 41) | | |
| | §2.1051 §27.53 (a)(4) | Conducted Spurious Emission (Band 30) | | |
| | §2.1051 §90.543 (e)(3) | Conducted Spurious Emission (Band 14) | | |
| 3.8 | §2.1055 §22.355 §24.235 §27.54 §90.539 (e) §90.691 | Frequency Stability Temperature & Voltage | Pass | - |
| 4.2 | §2.1053 §22.917 (a) §24.238 (a) §27.53 (c)(2) §27.53 (f) §27.53 (g) §27.53 (h) §90.691 | Radiated Spurious Emission (Band 2) (Band 4) (Band 5) (Band 12) (Band 13) (Band 17) (Band 25) (Band 26) (Band 66) (Band 71) | Pass | 10.49 dB under the limit at 9234.000 MHz for Primary Antenna |
| | §2.1053 §27.53 (m)(4) | Radiated Spurious Emission (Band 7) (Band 38) (Band 41) | | 10.64 dB under the limit at 9216.000 MHz for ASDIV Antenna |
| | §2.1053 §27.53 (a)(4) | Radiated Spurious Emission (Band 30) | | |
| | §2.1053 §90.543 (e)(3) §90.543 (f) | Radiated Spurious Emission (Band 14) | | |

Declaration of Conformity:

- The test results (PASS/FAIL) with all measurement uncertainty excluded are presented in accordance with the regulation limits or requirements declared by manufacturers. It's means measurement values may risk exceeding the limit of regulation standards, if measurement uncertainty is include in test results.
- The measurement uncertainty please refer to report "Uncertainty of Evaluation".

Comments and Explanations:

- The product specifications of the EUT presented in the report are declared by the manufacturer who shall take full responsibility for the authenticity.
- The G9FPL and G0B96 are 100% identical in Hardware / Software to each other, and only have different model names for separate marketing purposes. The test samples are all model G9FPL.

Reviewed by: William Chen

Report Producer: Cindy Liu



1 General Description

1.1 Product Feature of Equipment Under Test

| Product Feature | |
|---------------------------------|--|
| Equipment | Phone |
| Model Name | G9FPL, G0B96 |
| FCC ID | A4RG9FPL |
| EUT supports Radios application | GSM/EGPRS/WCDMA/HSPA/LTE/5G NR/NFC/GNSS/ UWB/WPT Client WLAN 11b/g/n HT20 WLAN 11a/n HT20/HT40 WLAN 11ac VHT20/VHT40/VHT80/VHT160 WLAN 11ax HE20/HE40/HE80/HE160 Bluetooth BR/EDR/LE |

Remark: The above EUT's information was declared by manufacturer.

| EUT Information List | |
|----------------------|-----------------------------------|
| S/N | Performed Test Item |
| 2A311FDHS0000P | Conducted Measurement ERP/EIRP |
| 2B021FDHS0004B | Radiated Spurious Emission |



1.2 Product Specification of Equipment Under Test

| Product Specification is subject to this standard | |
|---|---|
| Tx Frequency | LTE Band 2: 1850.7 MHz ~ 1909.3 MHz LTE Band 4: 1710.7 MHz ~ 1754.3 MHz LTE Band 5: 824.7 MHz ~ 848.3 MHz LTE Band 7: 2502.5 MHz ~ 2567.5 MHz LTE Band 12: 699.7 MHz ~ 715.3 MHz LTE Band 13: 779.5 MHz ~ 784.5 MHz LTE Band 14: 790.5 MHz ~ 795.5 MHz LTE Band 17: 706.5 MHz ~ 713.5 MHz LTE Band 25: 1850.7 MHz ~ 1914.3 MHz LTE Band 26: 824.7 MHz ~ 848.3 MHz (Part22H) LTE Band 26: 814.7 MHz ~ 823.3 MHz (Part90S) LTE Band 30: 2307.5 MHz ~ 2312.5 MHz LTE Band 38: 2572.5 MHz ~ 2617.5 MHz LTE Band 41: 2498.5 MHz ~ 2687.5 MHz LTE Band 66: 1710.7 MHz ~ 1754.3 MHz LTE Band 71: 665.5 MHz ~ 695.5 MHz |
| Rx Frequency | LTE Band 2: 1930.7 MHz ~ 1989.3 MHz LTE Band 4: 2110.7 MHz ~ 2154.3 MHz LTE Band 5: 869.7 MHz ~ 893.3 MHz LTE Band 7: 2622.5 MHz ~ 2687.5 MHz LTE Band 12: 729.7 MHz ~ 745.3 MHz LTE Band 13: 748.5 MHz ~ 753.5 MHz LTE Band 14: 760.5 MHz ~ 765.5 MHz LTE Band 17: 736.5 MHz ~ 743.5 MHz LTE Band 25: 1930.7 MHz ~ 1994.3 MHz LTE Band 26: 869.7MHz ~ 893.3MHz (Part22H) LTE Band 26: 859.7 MHz ~ 868.3 MHz (Part90S) LTE Band 30: 2352.5 MHz ~ 2357.5 MHz LTE Band 38: 2572.5MHz ~ 2617.5MHz LTE Band 41: 2498.5 MHz ~ 2687.5 MHz LTE Band 66: 2110.7 MHz ~ 2154.3 MHz LTE Band 71: 619.5 MHz ~ 649.5 MHz |
| Bandwidth | LTE Band 2: 1.4MHz / 3MHz / 5MHz / 10MHz / 15MHz / 20MHz LTE Band 4: 1.4MHz / 3MHz / 5MHz / 10MHz / 15MHz / 20MHz LTE Band 5: 1.4MHz / 3MHz / 5MHz / 10MHz LTE Band 7: 5MHz / 10MHz / 15MHz / 20MHz LTE Band 12: 1.4MHz / 3MHz / 5MHz / 10MHz LTE Band 13: 5MHz / 10MHz LTE Band 14: 5MHz / 10MHz LTE Band 17: 5MHz / 10MHz LTE Band 25: 1.4MHz / 3MHz / 5MHz / 10MHz / 15MHz / 20MHz LTE Band 26: 1.4MHz / 3MHz / 5MHz / 10MHz / 15MHz LTE Band 30: 5MHz / 10MHz LTE Band 38: 5MHz / 10MHz / 15MHz / 20MHz LTE Band 41: 5MHz / 10MHz / 15MHz / 20MHz LTE Band 66: 1.4MHz / 3MHz / 5MHz / 10MHz / 15MHz / 20MHz LTE Band 71: 5MHz / 10MHz / 15MHz / 20MHz |



| Product Specification is subject to this standard | |
|---|---|
| Maximum Output Power to Antenna | <p><Primary Antenna> <Ant. 0> LTE Band 5 : 24.34 dBm LTE Band 5B : 23.84 dBm LTE Band 12 : 24.60 dBm LTE Band 13 : 24.32 dBm LTE Band 14 : 24.34 dBm LTE Band 17 : 24.52 dBm LTE Band 26 : 24.43 dBm (Part22H) LTE Band 26 : 24.36 dBm (Part90S) LTE Band 71 : 24.68 dBm</p> <p><Ant. 2> LTE Band 2 : 24.69 dBm LTE Band 4 : 24.80 dBm LTE Band 7 : 24.82 dBm LTE Band 7C : 22.71 dBm LTE Band 25 : 24.72 dBm LTE Band 30 : 22.50 dBm LTE Band 38 : 24.64 dBm LTE Band 38 : 26.29 dBm for HPUE LTE Band 38C : 19.59 dBm LTE Band 41 : 24.35 dBm LTE Band 41 : 26.33 dBm for HPUE LTE Band 41C : 19.89 dBm LTE Band 66 : 24.83 dBm LTE Band 66B : 22.88 dBm LTE Band 66C : 22.98 dBm</p> <p><ASDIV Antenna> <Ant. 0> LTE Band 2 : 24.76 dBm LTE Band 4 : 24.74 dBm LTE Band 7 : 24.91 dBm LTE Band 7C : 24.24 dBm LTE Band 25 : 24.77 dBm LTE Band 30 : 22.49 dBm LTE Band 38 : 24.34 dBm LTE Band 38 : 25.98 dBm for HPUE LTE Band 38C : 19.33 dBm LTE Band 41 : 24.09 dBm LTE Band 41 : 25.99 dBm for HPUE LTE Band 41C : 19.49 dBm LTE Band 66 : 24.82 dBm LTE Band 66B : 23.40 dBm LTE Band 66C : 23.19 dBm</p> <p><Ant. 1> LTE Band 5 : 24.65 dBm LTE Band 5B : 23.25 dBm LTE Band 12 : 24.53 dBm LTE Band 13 : 24.32 dBm LTE Band 14 : 24.40 dBm LTE Band 17 : 24.37 dBm LTE Band 26 : 24.67 dBm (Part22H) LTE Band 26 : 24.49 dBm (Part90S) LTE Band 71 : 24.70 dBm</p> |



| Product Specification is subject to this standard | |
|---|--|
| Antenna Type | <Primary Antenna> <Ant. 0>: ILA Antenna <Ant. 2>: ILA Antenna <ASDIV Antenna> <Ant. 0>: ILA Antenna <Ant. 1>: ILA Antenna |
| Type of Modulation | QPSK / 16QAM / 64QAM / 256QAM |

<Open Mode>

<Primary Antenna>

| Radio Tech | Band Number | Antenna name | Gain |
|------------|-------------|--------------|-------|
| LTE | B2 | Ant. 2 | -2.16 |
| | | Ant. 1 | -3.46 |
| LTE | B4 | Ant. 2 | -0.02 |
| LTE | B5 | Ant. 0 | -1.90 |
| LTE | B7 | Ant. 2 | 0.32 |
| LTE | B12 | Ant. 0 | -1.02 |
| LTE | B13 | Ant. 0 | -1.38 |
| LTE | B14 | Ant. 0 | -2.49 |
| LTE | B17 | Ant. 0 | -1.28 |
| LTE | B25 | Ant. 2 | -2.13 |
| LTE | B26 | Ant. 0 | -1.90 |
| LTE | B30 | Ant. 2 | -0.10 |
| LTE | B38 | Ant. 2 | 0.90 |
| LTE | B41 | Ant. 2 | 0.84 |
| LTE | B66 | Ant. 2 | 0.05 |
| | | Ant. 1 | -7.58 |
| LTE | B71 | Ant. 0 | -0.04 |

<ASDIV Antenna>

| Radio Tech | Band Number | Antenna name | Gain |
|------------|-------------|--------------|--------|
| LTE | B2 | Ant. 0 | -2.16 |
| | | Ant. 5 | -14.76 |
| LTE | B4 | Ant. 0 | -1.88 |
| LTE | B5 | Ant. 1 | -5.40 |
| LTE | B7 | Ant. 0 | -0.66 |
| LTE | B12 | Ant. 1 | -5.60 |
| LTE | B13 | Ant. 1 | -5.36 |
| LTE | B14 | Ant. 1 | -5.48 |
| LTE | B17 | Ant. 1 | -5.60 |
| LTE | B25 | Ant. 0 | -2.15 |
| LTE | B26 | Ant. 1 | -5.40 |
| LTE | B30 | Ant. 0 | -2.43 |
| LTE | B38 | Ant. 0 | -1.49 |
| LTE | B41 | Ant. 0 | -0.44 |
| LTE | B66 | Ant. 0 | -1.78 |
| | | Ant. 5 | -18.82 |
| LTE | B71 | Ant. 1 | -4.51 |



<Close Mode>

<Primary Antenna>

| Radio Tech | Band Number | Antenna name | Gain |
|------------|-------------|--------------|-------|
| LTE | B2 | Ant. 2 | -0.25 |
| | | Ant. 1 | -0.73 |
| LTE | B4 | Ant. 2 | -1.32 |
| LTE | B5 | Ant. 0 | -5.08 |
| LTE | B7 | Ant. 2 | -0.49 |
| LTE | B12 | Ant. 0 | -5.52 |
| LTE | B13 | Ant. 0 | -4.27 |
| LTE | B14 | Ant. 0 | -4.86 |
| LTE | B17 | Ant. 0 | -5.41 |
| LTE | B25 | Ant. 2 | -0.25 |
| LTE | B26 | Ant. 0 | -5.08 |
| LTE | B30 | Ant. 2 | -1.10 |
| LTE | B38 | Ant. 2 | -0.55 |
| LTE | B41 | Ant. 2 | -0.20 |
| LTE | B66 | Ant. 2 | -1.32 |
| | | Ant. 1 | -4.54 |
| LTE | B71 | Ant. 0 | -6.56 |

<ASDIV Antenna>

| Radio Tech | Band Number | Antenna name | Gain |
|------------|-------------|--------------|--------|
| LTE | B2 | Ant. 0 | -1.93 |
| | | Ant. 5 | -18.37 |
| LTE | B4 | Ant. 0 | -3.98 |
| LTE | B5 | Ant. 1 | -9.33 |
| LTE | B7 | Ant. 0 | -5.62 |
| LTE | B12 | Ant. 1 | -7.76 |
| LTE | B13 | Ant. 1 | -7.37 |
| LTE | B14 | Ant. 1 | -7.37 |
| LTE | B17 | Ant. 1 | -7.68 |
| LTE | B25 | Ant. 0 | -1.93 |
| LTE | B26 | Ant. 1 | -9.33 |
| LTE | B30 | Ant. 0 | -3.79 |
| LTE | B38 | Ant. 0 | -5.59 |
| LTE | B41 | Ant. 0 | -5.42 |
| LTE | B66 | Ant. 0 | -3.98 |
| | | Ant. 5 | -20.99 |
| LTE | B71 | Ant. 1 | -9.17 |

Remark: The EUT's information above is declared by manufacturer. Please refer to Comments and Explanations in report summary.

1.3 Modification of EUT

No modifications made to the EUT during the testing.



1.4 Testing Location

| | | |
|------------------------------|--|-----------------------------------|
| Test Site | Sporton International Inc. EMC & Wireless Communications Laboratory | |
| Test Site Location | No.52, Huaya 1st Rd., Guishan Dist., Taoyuan City 333, Taiwan (R.O.C.) TEL: +886-3-327-3456 FAX: +886-3-328-4978 | |
| Test Site No. | Sporton Site No. | |
| | TH03-HY | 03CH07-HY |
| Test Engineer | HaoEn Zhang | Jesse Wang, Stan Hsieh and Ken Wu |
| Temperature (°C) | 21.3~22.6 | 18~23 |
| Relative Humidity (%) | 52.1~53.4 | 47~58 |

Note: The test site complies with ANSI C63.4 2014 requirement.

FCC Designation No.: TW1190

1.5 Applicable Standards

According to the specifications of the manufacturer, the EUT must comply with the requirements of the following standards:

- ♦ ANSI C63.26-2015
- ♦ ANSI / TIA-603-E
- ♦ FCC 47 CFR Part 2, 22(H), 24(E), 27, Part 90(R), Part 90(S)
- ♦ FCC KDB 971168 D01 Power Meas. License Digital Systems v03r01
- ♦ FCC KDB 412172 D01 Determining ERP and EIRP v01r01
- ♦ FCC KDB 414788 D01 Radiated Test Site v01r01.

Remark:

1. All the test items were validated and recorded in accordance with the standards without any modification during the testing.
2. The TAF code is not including all the FCC KDB listed without accreditation.



2 Test Configuration of Equipment Under Test

2.1 Test Mode

Antenna port conducted and radiated test items listed below are performed according to KDB 971168 D01 Power Meas. License Digital Systems v03r01 with maximum output power.

For radiated measurement, the measured emission level of the EUT was maximized by rotating the EUT on a turntable, adjusting the orientation of the EUT (open and close) and EUT antenna in three orthogonal axis (X: flat, Y: portrait, Z: landscape) and accessory (Adapter or Earphone), and adjusting the measurement antenna orientation, following C63.26 exploratory test procedures and only the worst case emissions were reported in this report.

| Test Items | Band | Bandwidth (MHz) | | | | | | Modulation | | | | RB # | | | Test Channel | | |
|-------------------|------|-----------------|---|---|----|----|----|------------|-------|-------|--------|------|------|------|--------------|---|---|
| | | 1.4 | 3 | 5 | 10 | 15 | 20 | QPSK | 16QAM | 64QAM | 256QAM | 1 | Half | Full | L | M | H |
| Max. Output Power | 2 | v | v | v | v | v | v | v | v | v | v | v | v | v | v | v | v |
| | 4 | v | v | v | v | v | v | v | v | v | v | v | v | v | v | v | v |
| | 5 | v | v | v | v | - | - | v | v | v | v | v | v | v | v | v | v |
| | 7 | - | - | v | v | v | v | v | v | v | v | v | v | v | v | v | v |
| | 12 | v | v | v | v | - | - | v | v | v | v | v | v | v | v | v | v |
| | 13 | - | - | v | v | - | - | v | v | v | v | v | v | v | v | v | v |
| | 14 | - | - | v | v | - | - | v | v | v | v | v | v | v | v | v | v |
| | 17 | - | - | v | v | - | - | v | v | v | v | v | v | v | v | v | v |
| | 25 | v | v | v | v | v | v | v | v | v | v | v | v | v | v | v | v |
| | 26 | v | v | v | v | v | - | v | v | v | v | v | v | v | v | v | v |
| | 30 | - | - | v | v | - | - | v | v | v | v | v | v | v | v | v | v |
| | 38 | - | - | v | v | v | v | v | v | v | v | v | v | v | v | v | v |
| | 41 | - | - | v | v | v | v | v | v | v | v | v | v | v | v | v | v |
| | 66 | v | v | v | v | v | v | v | v | v | v | v | v | v | v | v | v |
| 71 | - | - | v | v | v | v | v | v | v | v | v | v | v | v | v | v | |



| Test Items | Band | Bandwidth (MHz) | | | | | | Modulation | | | | RB # | | | Test Channel | | |
|------------------------|------|--------------------|---|---|----|----|----|------------|-------|-------|--------|------|------|------|--------------|---|---|
| | | 1.4 | 3 | 5 | 10 | 15 | 20 | QPSK | 16QAM | 64QAM | 256QAM | 1 | Half | Full | L | M | H |
| Peak-to-Average Ratio | 2 | Covered by Band 25 | | | | | | | | | | | | | | | |
| | 4 | Covered by Band 66 | | | | | | | | | | | | | | | |
| | 5 | Covered by Band 26 | | | | | | | | | | | | | | | |
| | 7 | - | - | | | | v | v | v | v | v | | | v | | v | |
| | 12 | | | | v | - | - | v | v | v | v | | | v | | v | |
| | 13 | - | - | | v | - | - | v | v | v | v | | | v | | v | |
| | 14 | - | - | | v | - | - | v | v | v | v | | | v | | v | |
| | 17 | Covered by Band 12 | | | | | | | | | | | | | | | |
| | 25 | | | | | | v | v | v | v | v | | | v | | v | |
| | 26 | | | | v | v | - | v | v | v | v | | | v | | v | |
| | 30 | - | - | | v | - | - | v | v | v | v | | | v | | v | |
| | 38 | Covered by Band 41 | | | | | | | | | | | | | | | |
| | 41 | - | - | | | | v | v | v | v | v | | | v | | v | |
| | 66 | | | | | | v | v | v | v | v | | | v | | v | |
| 71 | - | - | | | | v | v | v | v | v | | | v | | v | | |
| 26dB and 99% Bandwidth | 2 | Covered by Band 25 | | | | | | | | | | | | | | | |
| | 4 | Covered by Band 66 | | | | | | | | | | | | | | | |
| | 5 | Covered by Band 26 | | | | | | | | | | | | | | | |
| | 7 | - | - | v | v | v | v | v | v | v | v | | | v | | v | |
| | 12 | v | v | v | v | - | - | v | v | v | v | | | v | | v | |
| | 13 | - | - | v | v | - | - | v | v | v | v | | | v | | v | |
| | 14 | - | - | v | v | - | - | v | v | v | v | | | v | | v | |
| | 17 | Covered by Band 12 | | | | | | | | | | | | | | | |
| | 25 | v | v | v | v | v | v | v | v | v | v | | | v | | v | |
| | 26 | v | v | v | v | v | - | v | v | v | v | | | v | v | v | |
| | 30 | - | - | v | v | - | - | v | v | v | v | | | v | | v | |
| | 38 | Covered by Band 41 | | | | | | | | | | | | | | | |
| | 41 | - | - | v | v | v | v | v | v | v | v | | | v | | v | |
| | 66 | v | v | v | v | v | v | v | v | v | v | | | v | | v | |
| 71 | - | - | v | v | v | v | v | v | v | v | | | v | | v | | |



| Test Items | Band | Bandwidth (MHz) | | | | | | Modulation | | | | RB # | | | Test Channel | | | |
|-----------------------------|------|--------------------|---|---|----|----|----|------------|-------|-------|--------|------|------|------|--------------|---|---|---|
| | | 1.4 | 3 | 5 | 10 | 15 | 20 | QPSK | 16QAM | 64QAM | 256QAM | 1 | Half | Full | L | M | H | |
| Conducted Band Edge | 2 | Covered by Band 25 | | | | | | | | | | | | | | | | |
| | 4 | Covered by Band 66 | | | | | | | | | | | | | | | | |
| | 5 | Covered by Band 26 | | | | | | | | | | | | | | | | |
| | 7 | - | - | v | v | v | v | v | v | v | v | v | | v | v | | v | |
| | 12 | v | v | v | v | - | - | v | v | v | v | v | | v | v | | v | |
| | 13 | - | - | v | v | - | - | v | v | v | v | v | | v | v | | v | |
| | 14 | - | - | v | v | - | - | v | v | v | v | v | | v | v | | v | |
| | 17 | Covered by Band 12 | | | | | | | | | | | | | | | | |
| | 25 | v | v | v | v | v | v | v | v | v | v | v | | v | v | | v | |
| | 26 | v | v | v | v | v | - | v | v | v | v | v | | v | v | | v | |
| | 30 | - | - | v | v | - | - | v | v | v | v | v | | v | v | | v | |
| | 38 | Covered by Band 41 | | | | | | | | | | | | | | | | |
| | 41 | - | - | v | v | v | v | v | v | v | v | v | | v | v | | v | |
| | 66 | v | v | v | v | v | v | v | v | v | v | v | | v | v | | v | |
| 71 | - | - | v | v | v | v | v | v | v | v | v | | v | v | | v | | |
| Emission Mask | 14 | - | - | v | v | - | - | v | v | v | v | | v | v | v | v | | |
| | 26 | v | v | v | v | v | - | v | v | v | v | | v | v | | v | | |
| Conducted Spurious Emission | 2 | Covered by Band 25 | | | | | | | | | | | | | | | | |
| | 4 | Covered by Band 66 | | | | | | | | | | | | | | | | |
| | 5 | Covered by Band 26 | | | | | | | | | | | | | | | | |
| | 7 | - | - | v | v | v | v | v | | | | | v | | | v | v | v |
| | 12 | v | v | v | v | - | - | v | | | | | v | | | v | v | v |
| | 13 | - | - | v | v | - | - | v | | | | | v | | | v | v | v |
| | 14 | - | - | v | v | - | - | v | | | | | v | | | v | v | v |
| | 17 | Covered by Band 12 | | | | | | | | | | | | | | | | |
| | 25 | v | v | v | v | v | v | v | | | | | v | | | v | v | v |
| | 26 | v | v | v | v | v | - | v | | | | | v | | | v | v | v |
| | 30 | - | - | v | v | - | - | v | | | | | v | | | v | v | v |
| | 38 | Covered by Band 41 | | | | | | | | | | | | | | | | |
| | 41 | - | - | v | v | v | v | v | v | | | | v | | | v | v | v |
| | 66 | v | v | v | v | v | v | v | v | | | | v | | | v | v | v |
| 71 | - | - | v | v | v | v | v | v | | | | v | | | v | v | v | |



| Test Items | Band | Bandwidth (MHz) | | | | | | Modulation | | | | RB # | | | Test Channel | | | |
|---------------------|------|--------------------|---|---|----|----|----|------------|-------|-------|--------|------|------------|------|--------------|---|---|--|
| | | 1.4 | 3 | 5 | 10 | 15 | 20 | QPSK | 16QAM | 64QAM | 256QAM | 1 | Half | Full | L | M | H | |
| Frequency Stability | 2 | Covered by Band 25 | | | | | | | | | | | | | | | | |
| | 4 | Covered by Band 66 | | | | | | | | | | | | | | | | |
| | 5 | Covered by Band 26 | | | | | | | | | | | | | | | | |
| | 7 | - | - | | v | | | v | | | | | | | v | | v | |
| | 12 | | | | v | - | - | v | | | | | | | v | | v | |
| | 13 | - | - | | v | - | - | v | | | | | | | v | | v | |
| | 14 | - | - | | v | - | - | v | | | | | | | v | | v | |
| | 17 | Covered by Band 12 | | | | | | | | | | | | | | | | |
| | 25 | | | | v | | | v | | | | | | | v | | v | |
| | 26 | | | | v | | - | v | | | | | | | v | | v | |
| | 30 | - | - | | v | - | - | v | | | | | | | v | | v | |
| | 38 | Covered by Band 41 | | | | | | | | | | | | | | | | |
| | 41 | - | - | | v | | | v | | | | | | | v | | v | |
| | 66 | | | | v | | | v | | | | | | | v | | v | |
| | 71 | - | - | | v | | | v | | | | | | | v | | v | |
| E.R.P / E.I.R.P | 2 | v | v | v | v | v | v | v | v | v | v | v | Max. Power | | | | | |
| | 4 | v | v | v | v | v | v | v | v | v | v | v | | | | | | |
| | 5 | v | v | v | v | - | - | v | v | v | v | v | | | | | | |
| | 7 | - | - | v | v | v | v | v | v | v | v | v | | | | | | |
| | 12 | v | v | v | v | - | - | v | v | v | v | v | | | | | | |
| | 13 | - | - | v | v | - | - | v | v | v | v | v | | | | | | |
| | 14 | - | - | v | v | - | - | v | v | v | v | v | | | | | | |
| | 17 | - | - | v | v | - | - | v | v | v | v | v | | | | | | |
| | 25 | v | v | v | v | v | v | v | v | v | v | v | | | | | | |
| | 26 | v | v | v | v | v | - | v | v | v | v | v | | | | | | |
| | 30 | - | - | v | v | - | - | v | v | v | v | v | | | | | | |
| | 38 | - | - | v | v | v | v | v | v | v | v | v | | | | | | |
| | 41 | - | - | v | v | v | v | v | v | v | v | v | | | | | | |
| | 66 | v | v | v | v | v | v | v | v | v | v | v | | | | | | |
| 71 | - | - | v | v | v | v | v | v | v | v | v | | | | | | | |



| Test Items | Band | Bandwidth (MHz) | | | | | | Modulation | | | | RB # | | | Test Channel | | |
|----------------------------|--|--------------------|---|---|----|----|----|------------|-------|-------|--------|------|------|------|--------------|---|---|
| | | 1.4 | 3 | 5 | 10 | 15 | 20 | QPSK | 16QAM | 64QAM | 256QAM | 1 | Half | Full | L | M | H |
| Radiated Spurious Emission | 2 | Covered by Band 25 | | | | | | | | | | | | | | | |
| | 4 | Covered by Band 66 | | | | | | | | | | | | | | | |
| | 5 | Covered by Band 26 | | | | | | | | | | | | | | | |
| | 7 | Worst Case | | | | | | | | | | | | v | v | v | |
| | 12 | Worst Case | | | | | | | | | | | | v | v | v | |
| | 13 | Worst Case | | | | | | | | | | | | v | v | v | |
| | 14 | Worst Case | | | | | | | | | | | | v | v | v | |
| | 17 | Covered by Band 12 | | | | | | | | | | | | | | | |
| | 25 | Worst Case | | | | | | | | | | | | v | v | v | |
| | 26 | Worst Case | | | | | | | | | | | | v | v | v | |
| | 30 | Worst Case | | | | | | | | | | | | v | v | v | |
| | 38 | Covered by Band 41 | | | | | | | | | | | | | | | |
| | 41 | Worst Case | | | | | | | | | | | | v | v | v | |
| | 66 | Worst Case | | | | | | | | | | | | v | v | v | |
| 71 | Worst Case | | | | | | | | | | | | v | v | v | | |
| Remark | <ol style="list-style-type: none"> The mark "v" means that this configuration is chosen for testing The mark "-" means that this bandwidth is not supported. The device is investigated from 30MHz to 10 times of fundamental signal for radiated spurious emission test under different RB size/offset and modulations in exploratory test. Subsequently, only the worst case emissions are reported. All the radiated test cases were performed with Adapter 2 and USB Cable 1. During the preliminary test, both charging modes (Adapter mode and WPT Client mode) were verified. It is determined that the adapter mode is the worst case for official test. Wider operating range bandwidth covers narrower one when the power is higher or the same. For One representative bandwidth is selected to perform PAR and frequency stability. | | | | | | | | | | | | | | | | |



| Test Items | Band | Bandwidth (MHz) | | | | | Modulation | | | | RB # | | | Test Channel | | | | | |
|-----------------------------|---|-----------------|-----|------|------|-------|------------|-------|-------|--------|------------|------|------|--------------|---|---|---|---|---|
| | | 3+5 | 5+3 | 5+10 | 10+5 | 10+10 | QPSK | 16QAM | 64QAM | 256QAM | 1 | Half | Full | L | M | H | | | |
| Max. Output Power | 5B_CA | v | v | v | v | v | v | v | v | v | v | v | v | v | v | v | v | v | v |
| 26dB and 99% Bandwidth | 5B_CA | v | v | v | v | v | v | v | v | v | | | v | | | v | | v | |
| Conducted Band Edge | 5B_CA | v | v | v | v | v | v | v | v | v | v | | v | v | | v | | | v |
| Conducted Spurious Emission | 5B_CA | v | v | v | v | v | v | | | | v | | | | | | v | v | v |
| E.R.P. | 5B_CA | v | v | v | v | v | v | v | v | v | Max. Power | | | | | | | | |
| Radiated Spurious Emission | 5B_CA | Worst Case | | | | | | | | | | | v | v | v | | | | |
| Remark | <ol style="list-style-type: none"> The mark "v" means that this configuration is chosen for testing The mark "-" means that this bandwidth is not supported. The device is investigated from 30MHz to 10 times of fundamental signal for radiated spurious emission test under different RB size/offset and modulations in exploratory test. Subsequently, only the worst case emissions are reported. All the radiated test cases were performed with Adapter 2 and USB Cable 1. During the preliminary test, both charging modes (Adapter mode and WPT Client mode) were verified. It is determined that the adapter mode is the worst case for official test. | | | | | | | | | | | | | | | | | | |

| Test Items | Band | Bandwidth (MHz) | | | | | | Modulation | | | | RB # | | | Test Channel | | | |
|-----------------------------|---|-----------------|------|------|------|------|-------|------------|-------|-------|--------|------------|------|------|--------------|---|---|---|
| | | 5+5 | 5+10 | 10+5 | 5+15 | 15+5 | 10+10 | QPSK | 16QAM | 64QAM | 256QAM | 1 | Half | Full | L | M | H | |
| Max. Output Power | 66B_CA | v | v | v | v | v | v | v | v | v | v | v | v | v | v | v | v | |
| 26dB and 99% Bandwidth | 66B_CA | v | v | v | v | v | v | v | v | v | v | | | v | | | v | |
| Conducted Band Edge | 66B_CA | v | v | v | v | v | v | v | v | v | v | v | | v | v | | v | |
| Conducted Spurious Emission | 66B_CA | v | v | v | v | v | v | v | | | | v | | | | v | v | v |
| E.I.R.P. | 66B_CA | v | v | v | v | v | v | v | v | v | v | Max. Power | | | | | | |
| Radiated Spurious Emission | 66B_CA | Worst Case | | | | | | | | | | | v | v | v | | | |
| Remark | <ol style="list-style-type: none"> The mark "v" means that this configuration is chosen for testing The mark "-" means that this bandwidth is not supported. The device is investigated from 30MHz to 10 times of fundamental signal for radiated spurious emission test under different RB size/offset and modulations in exploratory test. Subsequently, only the worst case emissions are reported. All the radiated test cases were performed with Adapter 2 and USB Cable 1. During the preliminary test, both charging modes (Adapter mode and WPT Client mode) were verified. It is determined that the adapter mode is the worst case for official test. | | | | | | | | | | | | | | | | | |



| Test Items | Band | Bandwidth (MHz) | | | | | | | | | | Modulation | | | | RB # | | | Test Channel | | |
|-----------------------------|--|---------------------|-------|-------|-------|-------|------|------|-------|-------|-------|------------|-------|-------|--------|------------|------|------|--------------|---|---|
| | | 20+20 | 20+15 | 15+20 | 20+10 | 10+20 | 20+5 | 5+20 | 15+15 | 15+10 | 10+15 | QPSK | 16QAM | 64QAM | 256QAM | 1 | Half | Full | L | M | H |
| Max. Output Power | 7_CA | v | v | v | v | v | - | - | v | v | - | v | v | v | v | v | v | v | v | v | v |
| | 38_CA | v | - | - | - | - | - | - | v | - | - | v | v | v | v | v | v | v | v | v | v |
| | 41_CA | v | v | v | v | v | v | v | v | v | v | v | v | v | v | v | v | v | v | v | v |
| | 66_CA | v | v | v | v | v | v | v | v | v | v | v | v | v | v | v | v | v | v | v | v |
| 26dB and 99% Bandwidth | 7_CA | v | v | v | v | v | - | - | v | v | - | v | v | v | v | | | v | | v | |
| | 38_CA | v | - | - | - | - | - | - | v | - | - | v | v | v | v | | | v | | v | |
| | 41_CA | v | v | v | v | v | v | v | v | v | v | v | v | v | v | | | v | | v | |
| | 66_CA | v | v | v | v | v | v | v | v | v | v | v | v | v | v | | | v | | v | |
| Conducted Band Edge | 7_CA | v | v | v | v | v | - | - | v | v | - | v | v | v | v | v | | v | v | | v |
| | 38_CA | v | - | - | - | - | - | - | v | - | - | v | v | v | v | v | | v | v | | v |
| | 41_CA | v | v | v | v | v | v | v | v | v | v | v | v | v | v | v | | v | v | | v |
| | 66_CA | v | v | v | v | v | v | v | v | v | v | v | v | v | v | v | | v | v | | v |
| Conducted Spurious Emission | 7_CA | v | v | v | v | v | - | - | v | v | - | v | | | | v | | | v | v | v |
| | 38_CA | v | - | - | - | - | - | - | v | - | - | v | | | | v | | | v | v | v |
| | 41_CA | v | v | v | v | v | v | v | v | v | v | v | | | | v | | | v | v | v |
| | 66_CA | v | v | v | v | v | v | v | v | v | v | v | | | | v | | | v | v | v |
| E.I.R.P | 7_CA | v | v | v | v | v | - | - | v | v | - | v | v | v | v | Max. Power | | | | | |
| | 38_CA | v | - | - | - | - | - | - | v | - | - | v | v | v | v | | | | | | |
| | 41_CA | v | v | v | v | v | v | v | v | v | v | v | v | v | v | | | | | | |
| | 66_CA | v | v | v | v | v | v | v | v | v | v | v | v | v | v | | | | | | |
| Radiated Spurious Emission | 7_CA | Worst Case | | | | | | | | | | | | | | | | v | v | v | |
| | 38_CA | Covered by Band 41C | | | | | | | | | | | | | | | | | | | |
| | 41_CA | Worst Case | | | | | | | | | | | | | | | | v | v | v | |
| | 66_CA | Worst Case | | | | | | | | | | | | | | | | v | v | v | |
| Remark | <ol style="list-style-type: none"> The mark "v " means that this configuration is chosen for testing The mark "- " means that this bandwidth is not supported. The device is investigated from 30MHz to 10 times of fundamental signal for radiated spurious emission test under different RB size/offset and modulations in exploratory test. Subsequently, only the worst case emissions are reported. All the radiated test cases were performed with Adapter 2 and USB Cable 1. During the preliminary test, both charging modes (Adapter mode and WPT Client mode) were verified. It is determined that the adapter mode is the worst case for official test. Wider operating range bandwidth covers narrower one when the power is higher or the same. | | | | | | | | | | | | | | | | | | | | |

2.2 Connection Diagram of Test System

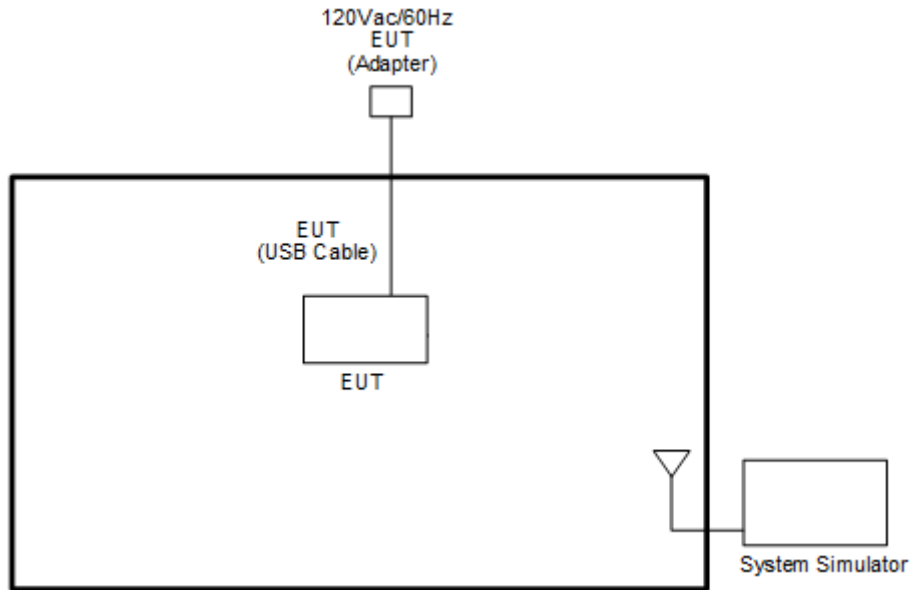

2.3 Support Unit used in test configuration and system

| Item | Equipment | Brand Name | Model No. | FCC ID | Data Cable | Power Cord |
|------|------------------|------------|-----------|--------|------------|-------------------|
| 1. | System Simulator | Anritsu | MT8821C | N/A | N/A | Unshielded, 1.8 m |

2.4 Measurement Results Explanation Example

For all conducted test items:

The offset level is set in the spectrum analyzer to compensate the RF cable loss and attenuator factor between EUT conducted output port and spectrum analyzer. With the offset compensation, the spectrum analyzer reading level is exactly the EUT RF output level.

The spectrum analyzer offset is derived from RF cable loss and attenuator factor.

Offset = RF cable loss + attenuator factor.

Following shows an offset computation example with cable loss 4.2 dB and 10dB attenuator.

Example :

$$\begin{aligned} \text{Offset(dB)} &= \text{RF cable loss(dB)} + \text{attenuator factor(dB)}. \\ &= 4.2 + 10 = 14.2 \text{ (dB)} \end{aligned}$$



2.5 Frequency List of Low/Middle/High Channels

| LTE Band 2 Channel and Frequency List | | | | |
|---------------------------------------|------------------------|--------|--------|---------|
| BW [MHz] | Channel/Frequency(MHz) | Lowest | Middle | Highest |
| 20 | Channel | 18700 | 18900 | 19100 |
| | Frequency | 1860 | 1880 | 1900 |
| 15 | Channel | 18675 | 18900 | 19125 |
| | Frequency | 1857.5 | 1880 | 1902.5 |
| 10 | Channel | 18650 | 18900 | 19150 |
| | Frequency | 1855 | 1880 | 1905 |
| 5 | Channel | 18625 | 18900 | 19175 |
| | Frequency | 1852.5 | 1880 | 1907.5 |
| 3 | Channel | 18615 | 18900 | 19185 |
| | Frequency | 1851.5 | 1880 | 1908.5 |
| 1.4 | Channel | 18607 | 18900 | 19193 |
| | Frequency | 1850.7 | 1880 | 1909.3 |

| LTE Band 4 Channel and Frequency List | | | | |
|---------------------------------------|------------------------|--------|--------|---------|
| BW [MHz] | Channel/Frequency(MHz) | Lowest | Middle | Highest |
| 20 | Channel | 20050 | 20175 | 20300 |
| | Frequency | 1720 | 1732.5 | 1745 |
| 15 | Channel | 20025 | 20175 | 20325 |
| | Frequency | 1717.5 | 1732.5 | 1747.5 |
| 10 | Channel | 20000 | 20175 | 20350 |
| | Frequency | 1715 | 1732.5 | 1750 |
| 5 | Channel | 19975 | 20175 | 20375 |
| | Frequency | 1712.5 | 1732.5 | 1752.5 |
| 3 | Channel | 19965 | 20175 | 20385 |
| | Frequency | 1711.5 | 1732.5 | 1753.5 |
| 1.4 | Channel | 19957 | 20175 | 20393 |
| | Frequency | 1710.7 | 1732.5 | 1754.3 |



| LTE Band 5 Channel and Frequency List | | | | |
|---------------------------------------|------------------------|--------|--------|---------|
| BW [MHz] | Channel/Frequency(MHz) | Lowest | Middle | Highest |
| 10 | Channel | 20450 | 20525 | 20600 |
| | Frequency | 829 | 836.5 | 844 |
| 5 | Channel | 20425 | 20525 | 20625 |
| | Frequency | 826.5 | 836.5 | 846.5 |
| 3 | Channel | 20415 | 20525 | 20635 |
| | Frequency | 825.5 | 836.5 | 847.5 |
| 1.4 | Channel | 20407 | 20525 | 20643 |
| | Frequency | 824.7 | 836.5 | 848.3 |

| LTE Band 7 Channel and Frequency List | | | | |
|---------------------------------------|------------------------|--------|--------|---------|
| BW [MHz] | Channel/Frequency(MHz) | Lowest | Middle | Highest |
| 20 | Channel | 20850 | 21100 | 21350 |
| | Frequency | 2510 | 2535 | 2560 |
| 15 | Channel | 20825 | 21100 | 21375 |
| | Frequency | 2507.5 | 2535 | 2562.5 |
| 10 | Channel | 20800 | 21100 | 21400 |
| | Frequency | 2505 | 2535 | 2565 |
| 5 | Channel | 20775 | 21100 | 21425 |
| | Frequency | 2502.5 | 2535 | 2567.5 |

| LTE Band 12 Channel and Frequency List | | | | |
|--|------------------------|--------|--------|---------|
| BW [MHz] | Channel/Frequency(MHz) | Lowest | Middle | Highest |
| 10 | Channel | 23060 | 23095 | 23130 |
| | Frequency | 704 | 707.5 | 711 |
| 5 | Channel | 23035 | 23095 | 23155 |
| | Frequency | 701.5 | 707.5 | 713.5 |
| 3 | Channel | 23025 | 23095 | 23165 |
| | Frequency | 700.5 | 707.5 | 714.5 |
| 1.4 | Channel | 23017 | 23095 | 23173 |
| | Frequency | 699.7 | 707.5 | 715.3 |



| LTE Band 13 Channel and Frequency List | | | | |
|--|------------------------|--------|--------|---------|
| BW [MHz] | Channel/Frequency(MHz) | Lowest | Middle | Highest |
| 10 | Channel | - | 23230 | - |
| | Frequency | - | 782 | - |
| 5 | Channel | 23205 | 23230 | 23255 |
| | Frequency | 779.5 | 782 | 784.5 |

| LTE Band 14 Channel and Frequency List | | | | |
|--|------------------------|--------|--------|---------|
| BW [MHz] | Channel/Frequency(MHz) | Lowest | Middle | Highest |
| 10 | Channel | - | 23330 | - |
| | Frequency | - | 793 | - |
| 5 | Channel | 23305 | 23330 | 23355 |
| | Frequency | 790.5 | 793 | 795.5 |

| LTE Band 17 Channel and Frequency List | | | | |
|--|------------------------|--------|--------|---------|
| BW [MHz] | Channel/Frequency(MHz) | Lowest | Middle | Highest |
| 10 | Channel | 23780 | 23790 | 23800 |
| | Frequency | 709 | 710 | 711 |
| 5 | Channel | 23755 | 23790 | 23825 |
| | Frequency | 706.5 | 710 | 713.5 |



| LTE Band 25 Channel and Frequency List | | | | |
|--|------------------------|--------|--------|---------|
| BW [MHz] | Channel/Frequency(MHz) | Lowest | Middle | Highest |
| 20 | Channel | 26140 | 26340 | 26590 |
| | Frequency | 1860 | 1880 | 1905 |
| 15 | Channel | 26115 | 26340 | 26615 |
| | Frequency | 1857.5 | 1880 | 1907.5 |
| 10 | Channel | 26090 | 26340 | 26640 |
| | Frequency | 1855 | 1880 | 1910 |
| 5 | Channel | 26065 | 26340 | 26665 |
| | Frequency | 1852.5 | 1880 | 1912.5 |
| 3 | Channel | 26055 | 26340 | 26675 |
| | Frequency | 1851.5 | 1880 | 1913.5 |
| 1.4 | Channel | 26047 | 26340 | 26683 |
| | Frequency | 1850.7 | 1880 | 1914.3 |

| LTE Band 26 Channel and Frequency List (Part22H) | | | | |
|--|------------------------|--------|--------|---------|
| BW [MHz] | Channel/Frequency(MHz) | Lowest | Middle | Highest |
| 15 | Channel | 26865 | 26915 | 26965 |
| | Frequency | 831.5 | 836.5 | 841.5 |
| 10 | Channel | 26840 | 26915 | 26990 |
| | Frequency | 829.0 | 836.5 | 844.0 |
| 5 | Channel | 26815 | 26915 | 27015 |
| | Frequency | 826.5 | 836.5 | 846.5 |
| 3 | Channel | 26805 | 26915 | 27025 |
| | Frequency | 825.5 | 836.5 | 847.5 |
| 1.4 | Channel | 26797 | 26915 | 27033 |
| | Frequency | 824.7 | 836.5 | 848.3 |



| LTE Band 26 Channel and Frequency List (Part90S) | | | | |
|--|------------------------|--------|--------|---------|
| BW [MHz] | Channel/Frequency(MHz) | Lowest | Middle | Highest |
| 15 | Channel | 26765 | - | - |
| | Frequency | 821.5 | - | - |
| 10 | Channel | - | 26740 | - |
| | Frequency | - | 819 | - |
| 5 | Channel | 26715 | 26740 | 26765 |
| | Frequency | 816.5 | 819 | 821.5 |
| 3 | Channel | 26705 | 26740 | 26775 |
| | Frequency | 815.5 | 819 | 822.5 |
| 1.4 | Channel | 26697 | 26740 | 26783 |
| | Frequency | 814.7 | 819 | 823.3 |

| LTE Band 26 Channel and Frequency List (Part90S) | | | | |
|--|------------------------|---|---------------------|---|
| BW [MHz] | Channel/Frequency(MHz) | - | cross-rule channels | - |
| 15 | Channel | - | 26790 | - |
| | Frequency | - | 824 | - |
| 10 | Channel | - | 26790 | - |
| | Frequency | - | 824 | - |
| 5 | Channel | - | 26790 | - |
| | Frequency | - | 824 | - |
| 3 | Channel | - | 26790 | - |
| | Frequency | - | 824 | - |
| 1.4 | Channel | - | 26790 | - |
| | Frequency | - | 824 | - |

| LTE Band 30 Channel and Frequency List | | | | |
|--|------------------------|--------|--------|---------|
| BW [MHz] | Channel/Frequency(MHz) | Lowest | Middle | Highest |
| 10 | Channel | - | 27710 | - |
| | Frequency | - | 2310 | - |
| 5 | Channel | 27685 | 27710 | 27735 |
| | Frequency | 2307.5 | 2310 | 2312.5 |



| LTE Band 38 Channel and Frequency List | | | | |
|--|------------------------|--------|--------|---------|
| BW [MHz] | Channel/Frequency(MHz) | Lowest | Middle | Highest |
| 20 | Channel | 37850 | 38000 | 38150 |
| | Frequency | 2580.0 | 2595.0 | 2610.0 |
| 15 | Channel | 37825 | 38000 | 38175 |
| | Frequency | 2577.5 | 2595.0 | 2612.5 |
| 10 | Channel | 37800 | 38000 | 38200 |
| | Frequency | 2575.0 | 2595.0 | 2615.0 |
| 5 | Channel | 37775 | 38000 | 38225 |
| | Frequency | 2572.5 | 2595.0 | 2617.5 |

| LTE Band 41 Channel and Frequency List | | | | |
|--|------------------------|--------|--------|---------|
| BW [MHz] | Channel/Frequency(MHz) | Lowest | Middle | Highest |
| 20 | Channel | 39750 | 40620 | 41490 |
| | Frequency | 2506.0 | 2593.0 | 2680.0 |
| 15 | Channel | 39725 | 40620 | 41515 |
| | Frequency | 2503.5 | 2593.0 | 2682.5 |
| 10 | Channel | 39700 | 40620 | 41540 |
| | Frequency | 2501.0 | 2593.0 | 2685.0 |
| 5 | Channel | 39675 | 40620 | 41565 |
| | Frequency | 2498.5 | 2593.0 | 2687.5 |



| LTE Band 66 Channel and Frequency List | | | | |
|--|------------------------|--------|--------|---------|
| BW [MHz] | Channel/Frequency(MHz) | Lowest | Middle | Highest |
| 20 | Channel | 132072 | 132322 | 132572 |
| | Frequency | 1720 | 1745 | 1770 |
| 15 | Channel | 132047 | 132322 | 132597 |
| | Frequency | 1717.5 | 1745 | 1772.5 |
| 10 | Channel | 132022 | 132322 | 132622 |
| | Frequency | 1715 | 1745 | 1775 |
| 5 | Channel | 131997 | 132322 | 132647 |
| | Frequency | 1712.5 | 1745 | 1777.5 |
| 3 | Channel | 131987 | 132322 | 132657 |
| | Frequency | 1711.5 | 1745 | 1778.5 |
| 1.4 | Channel | 131979 | 132322 | 132665 |
| | Frequency | 1710.7 | 1745 | 1779.3 |

| LTE Band 71 Channel and Frequency List | | | | |
|--|------------------------|--------|--------|---------|
| BW [MHz] | Channel/Frequency(MHz) | Lowest | Middle | Highest |
| 20 | Channel | 133222 | 133297 | 133372 |
| | Frequency | 673.0 | 680.5 | 688.0 |
| 15 | Channel | 133197 | 133297 | 133397 |
| | Frequency | 670.5 | 680.5 | 690.5 |
| 10 | Channel | 133172 | 133297 | 133422 |
| | Frequency | 668.0 | 680.5 | 693.0 |
| 5 | Channel | 133147 | 133297 | 133447 |
| | Frequency | 665.5 | 680.5 | 695.5 |



| LTE Band 5B Channel and Frequency List_CA | | | | | |
|---|------------------------|-----------|--------|--------|---------|
| BW [MHz] | Channel/Frequency(MHz) | | Lowest | Middle | Highest |
| 3 + 5 | PCC | Channel | 20416 | 20501 | 20586 |
| | | Frequency | 825.6 | 834.1 | 842.6 |
| | SCC | Channel | 20455 | 20540 | 20575 |
| | | Frequency | 829.5 | 838.0 | 841.5 |
| 5 + 3 | PCC | Channel | 20425 | 20510 | 20595 |
| | | Frequency | 826.5 | 835.0 | 843.5 |
| | SCC | Channel | 20464 | 20549 | 20634 |
| | | Frequency | 830.4 | 838.9 | 847.4 |
| 5 + 10 | PCC | Channel | 20428 | 20478 | 20528 |
| | | Frequency | 826.8 | 831.8 | 836.8 |
| | SCC | Channel | 20500 | 20550 | 20600 |
| | | Frequency | 834.0 | 839.0 | 844.0 |
| 10 + 5 | PCC | Channel | 20450 | 20500 | 20550 |
| | | Frequency | 829.0 | 834.0 | 839.0 |
| | SCC | Channel | 20522 | 20572 | 20622 |
| | | Frequency | 836.2 | 841.2 | 846.2 |
| 10 + 10 | PCC | Channel | 20450 | 20476 | 20501 |
| | | Frequency | 829.0 | 831.6 | 834.1 |
| | SCC | Channel | 20549 | 20575 | 20600 |
| | | Frequency | 838.9 | 841.5 | 844.0 |



| LTE Band 7C Channel and Frequency List_CA | | | | | |
|---|------------------------|-----------|--------|--------|---------|
| BW [MHz] | Channel/Frequency(MHz) | | Lowest | Middle | Highest |
| 20 + 20 | PCC | Channel | 20850 | 21001 | 21152 |
| | | Frequency | 2510.0 | 2525.1 | 2540.2 |
| | SCC | Channel | 21048 | 21199 | 21350 |
| | | Frequency | 2529.8 | 2544.9 | 2560.0 |
| 20 + 15 | PCC | Channel | 20850 | 21026 | 21201 |
| | | Frequency | 2510.0 | 2527.6 | 2545.1 |
| | SCC | Channel | 21021 | 21197 | 21372 |
| | | Frequency | 2527.1 | 2544.7 | 2562.2 |
| 15 + 20 | PCC | Channel | 20828 | 21003 | 21179 |
| | | Frequency | 2507.8 | 2525.3 | 2542.9 |
| | SCC | Channel | 20999 | 21174 | 21350 |
| | | Frequency | 2524.9 | 2542.4 | 2560.0 |
| 20 + 10 | PCC | Channel | 20850 | 21051 | 21251 |
| | | Frequency | 2510.0 | 2530.1 | 2550.1 |
| | SCC | Channel | 20994 | 21195 | 21395 |
| | | Frequency | 2524.4 | 2544.5 | 2564.5 |
| 10 + 20 | PCC | Channel | 20805 | 21006 | 21206 |
| | | Frequency | 2505.5 | 2525.6 | 2545.6 |
| | SCC | Channel | 20949 | 21150 | 21350 |
| | | Frequency | 2519.9 | 2540.0 | 2560.0 |
| 15 + 15 | PCC | Channel | 20825 | 21025 | 21225 |
| | | Frequency | 2507.5 | 2527.5 | 2547.5 |
| | SCC | Channel | 20975 | 21175 | 21375 |
| | | Frequency | 2522.5 | 2542.5 | 2562.5 |
| 15 + 10 | PCC | Channel | 20825 | 21051 | 21277 |
| | | Frequency | 2507.5 | 2530.1 | 2552.7 |
| | SCC | Channel | 20945 | 21171 | 21397 |
| | | Frequency | 2519.5 | 2542.1 | 2564.7 |



| LTE Band 38C Channel and Frequency List_CA | | | | | |
|--|------------------------|-----------|--------|--------|---------|
| BW [MHz] | Channel/Frequency(MHz) | | Lowest | Middle | Highest |
| 20 + 20 | PCC | Channel | 37850 | 37901 | 37952 |
| | | Frequency | 2580.0 | 2585.1 | 2590.2 |
| | SCC | Channel | 38048 | 38099 | 38150 |
| | | Frequency | 2599.8 | 2604.9 | 2610.0 |
| 15+ 15 | PCC | Channel | 37825 | 37925 | 38025 |
| | | Frequency | 2577.5 | 2587.5 | 2597.5 |
| | SCC | Channel | 37975 | 38075 | 38175 |
| | | Frequency | 2592.5 | 2602.5 | 2612.5 |

| LTE Band 41C Channel and Frequency List_CA | | | | | |
|--|------------------------|-----------|--------|--------|---------|
| BW [MHz] | Channel/Frequency(MHz) | | Lowest | Middle | Highest |
| 20 + 20 | PCC | Channel | 39750 | 40521 | 41292 |
| | | Frequency | 2506.0 | 2583.1 | 2660.2 |
| | SCC | Channel | 39948 | 40719 | 41490 |
| | | Frequency | 2525.8 | 2602.9 | 2680.0 |
| 20 + 15 | PCC | Channel | 39750 | 40546 | 41341 |
| | | Frequency | 2506.0 | 2585.6 | 2665.1 |
| | SCC | Channel | 39921 | 40717 | 41512 |
| | | Frequency | 2523.1 | 2602.7 | 2682.2 |
| 15 + 20 | PCC | Channel | 39728 | 40523 | 41319 |
| | | Frequency | 2503.8 | 2593.3 | 2662.9 |
| | SCC | Channel | 39899 | 40694 | 41490 |
| | | Frequency | 2520.9 | 2600.4 | 2680.0 |
| 20 + 10 | PCC | Channel | 39750 | 40571 | 41391 |
| | | Frequency | 2506.0 | 2588.1 | 2670.1 |
| | SCC | Channel | 39894 | 40715 | 41535 |
| | | Frequency | 2520.4 | 2602.5 | 2684.5 |
| 10 + 20 | PCC | Channel | 39705 | 40526 | 41346 |
| | | Frequency | 2501.5 | 2583.6 | 2665.6 |
| | SCC | Channel | 39849 | 40670 | 41490 |
| | | Frequency | 2515.9 | 2598.0 | 2680.0 |



| LTE Band 41C Channel and Frequency List_CA | | | | | |
|--|-----|-----------|--------|--------|--------|
| 20 + 5 | PCC | Channel | 39750 | 40595 | 41440 |
| | | Frequency | 2506.0 | 2590.5 | 2675.0 |
| | SCC | Channel | 39867 | 40712 | 41557 |
| | | Frequency | 2517.7 | 2602.2 | 2686.7 |
| 5 + 20 | PCC | Channel | 39683 | 40528 | 41373 |
| | | Frequency | 2499.3 | 2583.8 | 2668.3 |
| | SCC | Channel | 39800 | 40645 | 41490 |
| | | Frequency | 2511.0 | 2595.5 | 2680.0 |
| 15 + 15 | PCC | Channel | 39725 | 40545 | 41365 |
| | | Frequency | 2503.5 | 2585.5 | 2667.5 |
| | SCC | Channel | 39875 | 40695 | 41515 |
| | | Frequency | 2518.5 | 2600.5 | 2682.5 |
| 10 + 15 | PCC | Channel | 39703 | 40549 | 41395 |
| | | Frequency | 2501.3 | 2585.9 | 2670.5 |
| | SCC | Channel | 39823 | 40669 | 41515 |
| | | Frequency | 2513.3 | 2597.9 | 2682.5 |
| 15 + 10 | PCC | Channel | 39725 | 40571 | 41417 |
| | | Frequency | 2503.5 | 2588.1 | 2672.7 |
| | SCC | Channel | 39845 | 40691 | 41537 |
| | | Frequency | 2515.5 | 2600.1 | 2684.7 |



| LTE Band 66B Channel and Frequency List_CA | | | | | |
|--|------------------------|-----------|--------|--------|---------|
| BW [MHz] | Channel/Frequency(MHz) | | Lowest | Middle | Highest |
| 5 + 5 | PCC | Channel | 131997 | 132398 | 132599 |
| | | Frequency | 1712.5 | 1752.6 | 1772.7 |
| | SCC | Channel | 132045 | 133346 | 132647 |
| | | Frequency | 1717.3 | 1757.4 | 1777.5 |
| 5 + 10 | PCC | Channel | 132000 | 132375 | 132550 |
| | | Frequency | 1712.8 | 1750.3 | 1767.8 |
| | SCC | Channel | 132072 | 133347 | 132622 |
| | | Frequency | 1720.0 | 1757.5 | 1775.0 |
| 10 + 5 | PCC | Channel | 132022 | 132397 | 132572 |
| | | Frequency | 1715.0 | 1752.5 | 1770.0 |
| | SCC | Channel | 132094 | 133369 | 132644 |
| | | Frequency | 1722.2 | 1759.7 | 1777.2 |
| 5 + 15 | PCC | Channel | 132002 | 132353 | 132504 |
| | | Frequency | 1713.0 | 1748.1 | 1763.2 |
| | SCC | Channel | 132095 | 133346 | 132597 |
| | | Frequency | 1722.3 | 1757.4 | 1772.5 |
| 15 + 5 | PCC | Channel | 132047 | 132398 | 132549 |
| | | Frequency | 1717.5 | 1752.6 | 1767.7 |
| | SCC | Channel | 132140 | 133391 | 132642 |
| | | Frequency | 1726.8 | 1761.9 | 1777.0 |
| 10 + 10 | PCC | Channel | 132022 | 132373 | 135523 |
| | | Frequency | 1715.0 | 1750.1 | 1765.1 |
| | SCC | Channel | 132121 | 133372 | 132622 |
| | | Frequency | 1724.9 | 1760.0 | 1775.0 |



| LTE Band 66C Channel and Frequency List_CA | | | | | |
|--|------------------------|-----------|--------|--------|---------|
| BW [MHz] | Channel/Frequency(MHz) | | Lowest | Middle | Highest |
| 10 + 15 | PCC | Channel | 132025 | 132351 | 132477 |
| | | Frequency | 1715.3 | 1747.9 | 1760.5 |
| | SCC | Channel | 132145 | 133371 | 132597 |
| | | Frequency | 1727.3 | 1759.9 | 1772.5 |
| 15 + 10 | PCC | Channel | 132047 | 132373 | 132499 |
| | | Frequency | 1717.5 | 1750.1 | 1762.7 |
| | SCC | Channel | 132167 | 133393 | 132619 |
| | | Frequency | 1729.5 | 1761.1 | 1774.7 |
| 10 + 20 | PCC | Channel | 132027 | 132328 | 132428 |
| | | Frequency | 1715.5 | 1745.6 | 1755.6 |
| | SCC | Channel | 131171 | 133372 | 132572 |
| | | Frequency | 1729.9 | 1760.0 | 1770.0 |
| 20 + 10 | PCC | Channel | 132072 | 132373 | 132473 |
| | | Frequency | 1720.0 | 1750.1 | 1760.1 |
| | SCC | Channel | 132216 | 133417 | 132617 |
| | | Frequency | 1734.4 | 1764.5 | 1774.5 |
| 15 + 15 | PCC | Channel | 132047 | 132347 | 132447 |
| | | Frequency | 1717.5 | 1747.5 | 1757.5 |
| | SCC | Channel | 132197 | 133397 | 132597 |
| | | Frequency | 1732.5 | 1762.5 | 1772.5 |
| 15 + 20 | PCC | Channel | 132050 | 132325 | 132401 |
| | | Frequency | 1717.8 | 1745.3 | 1752.9 |
| | SCC | Channel | 132221 | 133396 | 132572 |
| | | Frequency | 1734.9 | 1762.4 | 1770.0 |
| 20 + 15 | PCC | Channel | 132072 | 132348 | 132423 |
| | | Frequency | 1720.0 | 1747.6 | 1755.1 |
| | SCC | Channel | 132243 | 133419 | 132594 |
| | | Frequency | 1737.1 | 1764.7 | 1772.2 |
| 20 + 5 | PCC | Channel | 132072 | 132397 | 132522 |
| | | Frequency | 1720.0 | 1752.5 | 1765.0 |
| | SCC | Channel | 132189 | 133414 | 132639 |
| | | Frequency | 1731.7 | 1764.2 | 1776.7 |



| LTE Band 66C Channel and Frequency List_CA | | | | | |
|--|-----|-----------|--------|--------|--------|
| 5 + 20 | PCC | Channel | 132005 | 132330 | 132455 |
| | | Frequency | 1713.3 | 1745.8 | 1758.3 |
| | SCC | Channel | 132122 | 132447 | 132572 |
| | | Frequency | 1725.0 | 1757.5 | 1770.0 |
| 20 + 20 | PCC | Channel | 132072 | 132323 | 132374 |
| | | Frequency | 1720.0 | 1745.1 | 1750.2 |
| | SCC | Channel | 132270 | 133421 | 132572 |
| | | Frequency | 1739.8 | 1764.9 | 1770.0 |

3 Conducted Test Items

3.1 Measuring Instruments

See list of measuring instruments of this test report.

3.1.1 Test Setup

3.1.2 Conducted Output Power

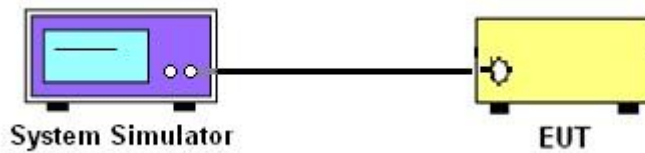

3.1.3 Peak-to-Average Ratio, Occupied Bandwidth ,Conducted Band-Edge, Emission Mask and Conducted Spurious Emission

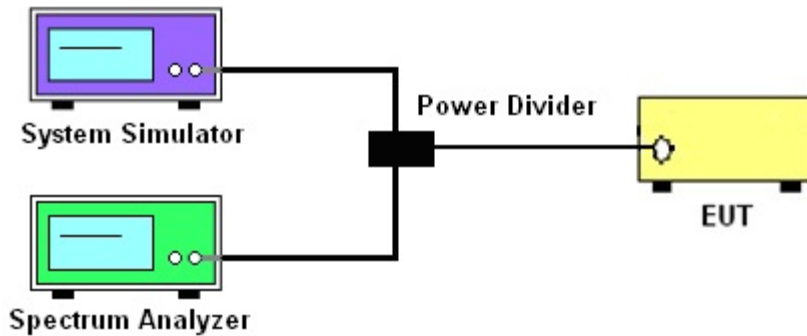

3.1.4 Frequency Stability

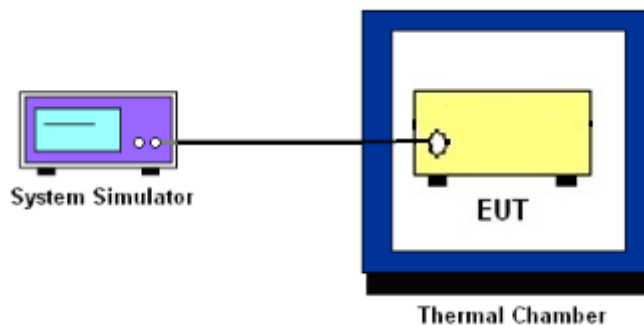

3.1.5 Test Result of Conducted Test

Please refer to Appendix A.



3.2 Conducted Output Power and ERP/EIRP

3.2.1 Description of the Conducted Output Power Measurement and ERP/EIRP Measurement

A system simulator was used to establish communication with the EUT. Its parameters were set to force the EUT transmitting at maximum output power. The measured power in the radio frequency on the transmitter output terminals shall be reported.

The ERP of mobile transmitters must not exceed 7 Watts for LTE Band 5, Band 26 (Part 22H)

The output power of mobile transmitters must not exceed 100 Watts for LTE Band 26 (Part 90S)

The ERP of mobile transmitters must not exceed 3 Watts for LTE Band 12, Band 13, Band 14, Band 17, Band 71

The EIRP of mobile transmitters must not exceed 2 Watts for LTE Band 2, Band 25, Band 7, Band 38, Band 41

The EIRP of mobile transmitters must not exceed 1 Watts for LTE Band 4, Band 66

The EIRP of mobile transmitters must not exceed 250mW/5MHz for LTE Band 30

According to KDB 412172 D01 Power Approach,

$EIRP = P_T + G_T - L_C$, $ERP = EIRP - 2.15$, where

P_T = transmitter output power in dBm

G_T = gain of the transmitting antenna in dBi

L_C = signal attenuation in the connecting cable between the transmitter and antenna in dB

3.2.2 Test Procedures

1. The transmitter output port was connected to the system simulator.
2. Set EUT at maximum power through the system simulator.
3. Select lowest, middle, and highest channels for each band and different modulation.
4. Measure and record the power level from the system simulator.



3.3 Peak-to-Average Ratio

3.3.1 Description of the PAR Measurement

Power Complementary Cumulative Distribution Function (CCDF) curves provide a means for characterizing the power peaks of a digitally modulated signal on a statistical basis. A CCDF curve depicts the probability of the peak signal amplitude exceeding the average power level. Most contemporary measurement instrumentation include the capability to produce CCDF curves for an input signal provided that the instrument's resolution bandwidth can be set wide enough to accommodate the entire input signal bandwidth. In measuring transmissions in this band using an average power technique, the peak-to-average ratio (PAR) of the transmission may not exceed 13 dB.

3.3.2 Test Procedures

The testing follows ANSI C63.26-2015 Section 5.2.6

1. The EUT was connected to spectrum and system simulator via a power divider.
2. Set the CCDF (Complementary Cumulative Distribution Function) option in spectrum analyzer.
3. The highest RF powers were measured and recorded the maximum PAPR level associated with a probability of 0.1 %.
4. Record the deviation as Peak to Average Ratio.



3.4 Occupied Bandwidth

3.4.1 Description of Occupied Bandwidth Measurement

The occupied bandwidth is the width of a frequency band such that, below the lower and above the upper frequency limits, the mean powers emitted are each equal to a specified percentage 0.5% of the total mean transmitted power.

The 26 dB emission bandwidth is defined as the frequency range between two points, one above and one below the carrier frequency, at which the spectral density of the emission is attenuated 26 dB below the maximum in-band spectral density of the modulated signal. Spectral density (power per unit bandwidth) is to be measured with a detector of resolution bandwidth equal to approximately 1.0% of the emission bandwidth.

3.4.2 Test Procedures

The testing follows ANSI C63.26-2015 Section 5.4.3 (26dB) and Section 5.4.4 (99OB)

1. The EUT was connected to spectrum analyzer and system simulator via a power divider.
2. The spectrum analyzer center frequency is set to the nominal EUT channel center frequency. The span range for the spectrum analyzer shall be between two and five times the anticipated OBW.
3. The nominal resolution bandwidth (RBW) shall be in the range of 1 to 5 % of the anticipated OBW, and the VBW shall be at least 3 times the RBW.
4. Set the detection mode to peak, and the trace mode to max hold.
5. Determine the reference value: Set the EUT to transmit a modulated signal. Allow the trace to stabilize. Set the spectrum analyzer marker to the highest level of the displayed trace.
(this is the reference value)
6. Determine the “-26 dB down amplitude” as equal to (Reference Value – X).
7. Place two markers, one at the lowest and the other at the highest frequency of the envelope of the spectral display such that each marker is at or slightly below the “-X dB down amplitude” determined in step 6. If a marker is below this “-X dB down amplitude” value it shall be placed as close as possible to this value. The OBW is the positive frequency difference between the two markers.
8. Use the 99 % power bandwidth function of the spectrum analyzer and report the measured bandwidth.



3.5 Conducted Band Edge

3.5.1 Description of Conducted Band Edge Measurement

22.917(a)

For operations in the 824 – 849 MHz band, the FCC limit is $43 + 10\log_{10}(P[\text{Watts}])$ dB below the transmitter power $P(\text{Watts})$ in a 100kHz bandwidth. However, in the 1MHz bands immediately outside and adjacent to the licensee's frequency block, a resolution bandwidth of at least one percent of the emission bandwidth of the fundamental emission of the transmitter may be employed.

24.238 (a)

For operations in the 1850-1910 and 1930-1990 MHz band, the FCC limit is $43 + 10\log_{10}(P[\text{Watts}])$ dB below the transmitter power $P(\text{Watts})$ in a 1MHz bandwidth. However, in the 1 MHz bands immediately outside and adjacent to the frequency block a resolution bandwidth of at least one percent of the emission bandwidth of the fundamental emission of the transmitter may be employed.

27.53 (c)

For operations in the 776-788 MHz band, the FCC limit is $43 + 10\log_{10}(P[\text{Watts}])$ dB below the transmitter power $P(\text{Watts})$ in a 100 kHz bandwidth. However, in the 100 kHz bands immediately outside and adjacent to the frequency block, a resolution bandwidth of at least 30 kHz may be employed. In addition, the power of any unwanted emissions in any 6.25 kHz bandwidth for all frequencies between 763-775 MHz and 793-806 MHz shall be attenuated below the transmitter power, P (dBW), by at least $65 + 10 \log_{10} p(\text{watts})$, dB, for mobile and portable equipment.

27.53 (g)

For operations in the 600MHz band and 698-746 MHz band, the FCC limit is $43 + 10\log_{10}(P[\text{Watts}])$ dB below the transmitter power $P(\text{Watts})$ in a 100 kHz bandwidth. However, in the 100 kilohertz bands immediately outside and adjacent to a licensee's frequency block, a resolution bandwidth of at least 30 kHz may be employed.

27.53 (h)

For operations in the 1710 – 1755 MHz band, 1755-1780 MHz, the FCC limit is $43 + 10\log_{10}(P[\text{Watts}])$ dB below the transmitter power $P(\text{Watts})$ in a 1 MHz bandwidth. However, in the 1MHz bands immediately outside and adjacent to the licensee's frequency block, a resolution bandwidth of at least one percent of the emission bandwidth of the fundamental emission of the transmitter may be employed.

**27.53(m)(4)**

For mobile digital stations, the attenuation factor shall be not less than $40 + 10 \log (P)$ dB on all frequencies between the channel edge and 5 megahertz from the channel edge, $43 + 10 \log (P)$ dB on all frequencies between 5 megahertz and X megahertz from the channel edge, and $55 + 10 \log (P)$ dB on all frequencies more than X megahertz from the channel edge, where X is the greater of 6 megahertz or the actual emission bandwidth as defined in paragraph (m)(6) of this section. In addition, the attenuation factor shall not be less that $43 + 10 \log (P)$ dB on all frequencies between 2490.5 MHz and 2496 MHz and $55 + 10 \log (P)$ dB at or below 2490.5 MHz. Mobile Satellite Service licensees operating on frequencies below 2495 MHz may also submit a documented interference complaint against BRS licensees operating on channel BRS Channel 1 on the same terms and conditions as adjacent channel BRS or EBS licensees.

27.53 (a)(4)

For mobile and portable stations operating in the 2305-2315 MHz and 2350-2360 MHz bands:

- (i) By a factor of not less than: $43 + 10 \log (P)$ dB on all frequencies between 2305 and 2320 MHz and on all frequencies between 2345 and 2360 MHz that are outside the licensed band(s) of operation, not less than $55 + 10 \log (P)$ dB on all frequencies between 2320 and 2324 MHz and on all frequencies between 2341 and 2345 MHz, not less than $61 + 10 \log (P)$ dB on all frequencies between 2324 and 2328 MHz and on all frequencies between 2337 and 2341 MHz, and not less than $67 + 10 \log (P)$ dB on all frequencies between 2328 and 2337 MHz.
- (ii) By a factor of not less than $43 + 10 \log (P)$ dB on all frequencies between 2300 and 2305 MHz, $55 + 10 \log (P)$ dB on all frequencies between 2296 and 2300 MHz, $61 + 10 \log (P)$ dB on all frequencies between 2292 and 2296 MHz, $67 + 10 \log (P)$ dB on all frequencies between 2288 and 2292 MHz, and $70 + 10 \log (P)$ dB below 2288 MHz.
- (iii) By a factor of not less than $43 + 10 \log (P)$ dB on all frequencies between 2360 and 2365 MHz, and not less than $70 + 10 \log (P)$ dB above 2365 MHz.

90.543(e)

- (1) On all frequencies between 769-775 MHz and 799-805 MHz, by a factor not less than $76 + 10 \log (P)$ dB in a 6.25 kHz band segment, for base and fixed stations.
- (2) On all frequencies between 769-775 MHz and 799-805 MHz, by a factor not less than $65 + 10 \log (P)$ dB in a 6.25 kHz band segment, for mobile and portable stations.
- (3) On any frequency between 775-788 MHz, above 805 MHz, and below 758 MHz, by at least $43 + 10 \log (P)$ dB.



3.5.2 Test Procedures

The testing follows FCC KDB 971168 D01 v03r01 Section 6.1.

1. The EUT was connected to spectrum analyzer and system simulator via a power divider.
2. The band edges of low and high channels for the highest RF powers were measured.
3. Set RBW \geq 1% EBW in the 1MHz band immediately outside and adjacent to the band edge.
4. Beyond the 1 MHz band from the band edge, RBW=1MHz was used.
5. Set spectrum analyzer with RMS detector.
6. The RF fundamental frequency should be excluded against the limit line in the operating frequency band.
7. Checked that all the results comply with the emission limit line.

The limit line is derived from $43 + 10\log(P)$ dB below the transmitter power P(Watts)

For LTE Band 7, 38, 41

The other 40 dB, and 55 dB have additionally applied same calculation above.



3.6 Emission Mask

3.6.1 Description of Emissions Mask Measurement

For LTE Band 14

Transmitters designed must meet the emission mask comply with the emission mask provisions of FCC Part 90.210(n).

For LTE Band 26

Equipment used in this licensed to EA or non-EA systems shall comply with the emission mask provisions of FCC Part 90.691

(a) Out-of-band emission requirement shall apply only to the "outer" channels included in an EA license and to spectrum adjacent to interior channels used by incumbent licensees. The emission limits are as follows:

(1) For any frequency removed from the EA licensee's frequency block by up to and including 37.5 kHz, the power of any emission shall be attenuated below the transmitter power (P) in watts by at least $116 \text{ Log}_{10}(f/6.1)$ decibels or $50 + 10 \text{ Log}_{10}(P)$ decibels or 80 decibels, whichever is the lesser attenuation, where f is the frequency removed from the center of the outer channel in the block in kilohertz and where f is greater than 12.5 kHz.

(2) For any frequency removed from the EA licensee's frequency block greater than 37.5 kHz, the power of any emission shall be attenuated below the transmitter power (P) in watts by at least $43 + 10 \text{ Log}_{10}(P)$ decibels or 80 decibels, whichever is the lesser attenuation, where f is the frequency removed from the center of the outer channel in the block in kilohertz and where f is greater than 37.5 kHz.



3.6.2 Test Procedures

For LTE Band 14

The testing follows FCC KDB 971168 D01 v03r01 Section 6.0.

1. The EUT was connected to spectrum analyzer and system simulator via a power divider.
2. The power of the modulated signal was measured on a spectrum analyzer using an RMS and 10 second sweep time in order to maximize the level.
3. The RF fundamental frequency should be excluded against the limit line in the operating frequency band.

For LTE Band 26

1. The EUT was connected to spectrum analyzer and base station via power divider.
2. The emissions mask of low and high channels for the highest RF powers were measured.
3. Set RBW and VBW 3 times of RBW to make the measurement with the spectrum analyzer's, and according to KDB 971168 D02 Misc Rev Approve License Devices v02r01 standards, set RBW = 300 Hz to make offsets less than 37.5 kHz from a channel edge , RBW = 100 kHz to make offsets greater than 37.5 kHz, that is allowed.
4. The test results were shown below plots with a correction offset factor including cable loss, insertion loss of power divider.



3.7 Conducted Spurious Emission

3.7.1 Description of Conducted Spurious Emission Measurement

The power of any emission outside of the authorized operating frequency ranges must be lower than the transmitter power (P) by a factor of at least $43 + 10 \log (P)$ dB.

For LTE Band 30

The power of any emission outside of the authorized operating frequency ranges must be lower than the transmitter power (P) by a factor of at least $70 + 10 \log (P)$ dB.

For LTE Band 7, 38, 41

The power of any emission outside of the authorized operating frequency ranges must be lower than the transmitter power (P) by a factor of at least $55 + 10 \log (P)$ dB.

It is measured by means of a calibrated spectrum analyzer and scanned from 30 MHz up to a frequency including its 10th harmonic.

3.7.2 Test Procedures

The testing follows FCC KDB 971168 D01 v03r01 Section 6.1.

1. The EUT was connected to spectrum analyzer and system simulator via a power divider.
2. The RF output of EUT was connected to the spectrum analyzer by RF cable and attenuator.
The path loss was compensated to the results for each measurement.
3. The conducted spurious emission for the whole frequency range was taken.
4. Make the measurement with the spectrum analyzer's RBW = 100 kHz if the authorized frequency band/block is at or below 1 GHz and 1 MHz if the authorized frequency band/block is above 1 GH, VBW = 3 * RBW.
5. Set spectrum analyzer with RMS detector.
6. Taking the record of maximum spurious emission.
7. The RF fundamental frequency should be excluded against the limit line in the operating frequency band.
8. The limit line is derived from $43 + 10\log(P)$ dB below the transmitter power P(Watts)
For LTE Band 30
The limit line is derived from $70 + 10\log(P)$ dB below the transmitter power P(Watts)
For LTE Band 7, 38, 41
The limit line is derived from $55 + 10\log(P)$ dB below the transmitter power P(Watts)



3.8 Frequency Stability

3.8.1 Description of Frequency Stability Measurement

The frequency stability shall be sufficient to ensure that the fundamental emission stays within the authorized frequency block.

22.355

The frequency stability shall be measured by variation of ambient temperature and variation of primary supply voltage to ensure that the fundamental emission stays within the authorized frequency block.

The frequency stability of the transmitter shall be maintained within $\pm 0.00025\%$ ($\pm 2.5\text{ppm}$) of the center frequency.

3.8.2 Test Procedures for Temperature Variation

The testing follows FCC KDB 971168 D01 v03r01 Section 9.0.

1. The EUT was set up in the thermal chamber and connected with the system simulator.
2. With power OFF, the temperature was decreased to -30°C and the EUT was stabilized before testing. Power was applied and the maximum change in frequency was recorded within one minute.
3. With power OFF, the temperature was raised in 10°C step up to 50°C . The EUT was stabilized at each step for at least half an hour. Power was applied and the maximum frequency change was recorded within one minute.

3.8.3 Test Procedures for Voltage Variation

The testing follows FCC KDB 971168 D01 v03r01 Section 9.0.

1. The EUT was placed in a temperature chamber at $20\pm 5^{\circ}\text{C}$ and connected with the system simulator.
2. The power supply voltage to the EUT was varied from 85% to 115% of the nominal value measured at the input to the EUT.
3. The variation in frequency was measured for the worst case.

4 Radiated Test Items

4.1 Measuring Instruments

See list of measuring instruments of this test report.

4.1.1 Test Setup

For radiated test below 30MHz

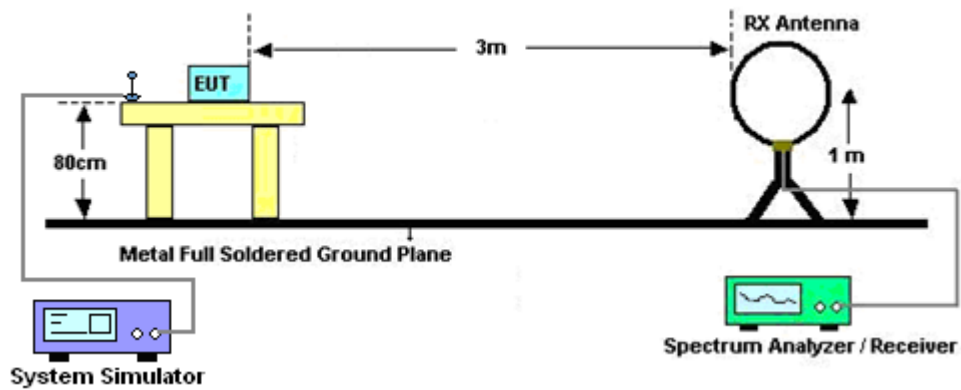

For radiated test from 30MHz to 1GHz

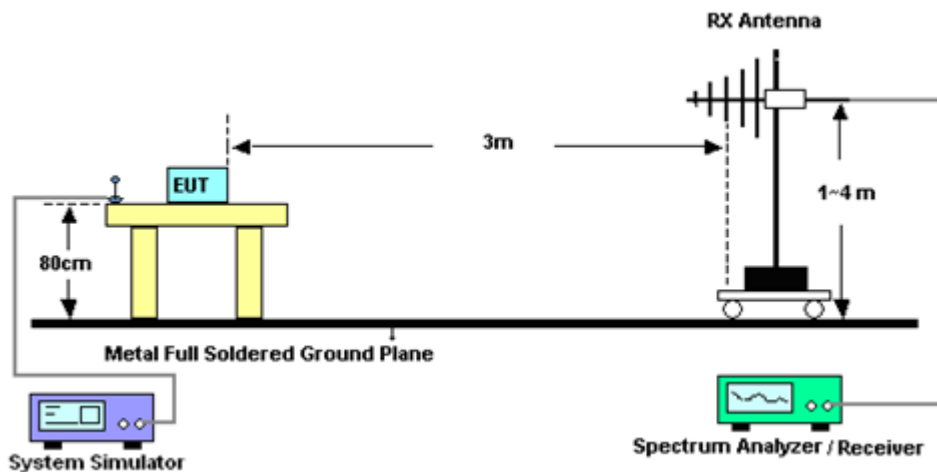

For radiated test from 1GHz to 18GHz

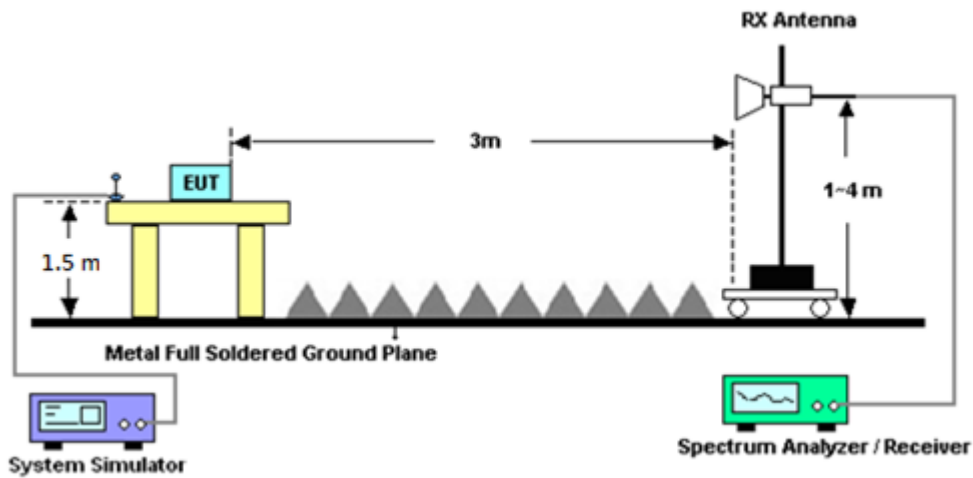

For radiated test above 18GHz

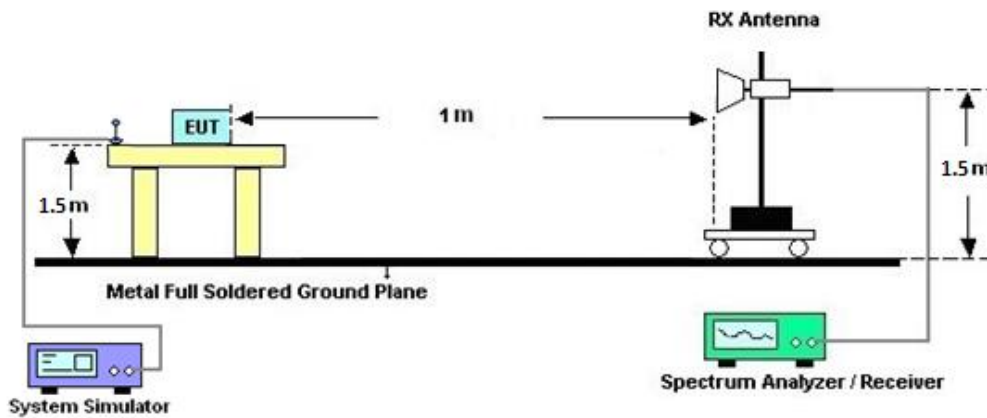

4.1.2 Test Result of Radiated Test

Please refer to Appendix B.

Note:

The low frequency, which started from 9 kHz to 30MHz, was pre-scanned and the result which was 20dB lower than the limit line was not reported.

There is adequate comparison measurement of both open-field test site and alternative test site - semi-Anechoic chamber according to 414788 D01 Radiated Test Site v01r01, and the result came out very similar.



4.2 Radiated Spurious Emission Measurement

4.2.1 Description of Radiated Spurious Emission Measurement

The radiated spurious emission was measured by substitution method according to ANSI / TIA-603-E. The power of any emission outside of the authorized operating frequency ranges must be attenuated below the transmitter power (P) by a factor of at least $43 + 10 \log (P)$ dB.

For LTE Band 7, 38, 41

The power of any emission outside of the authorized operating frequency ranges must be attenuated below the transmitter power (P) by a factor of at least $55 + 10 \log (P)$ dB.

For LTE Band 13

For operations in the 746-758 MHz, 775-788 MHz, and 805-806 MHz bands, emissions in the band 1559-1610 MHz shall be limited to -70 dBW/MHz equivalent isotropically radiated power (EIRP) for wideband signals, and -80 dBW EIRP for discrete emissions of less than 700 Hz bandwidth.

For LTE Band 30

The power of any emission outside of the authorized operating frequency ranges must be attenuated below the transmitter power (P) by a factor of at least $70 + 10 \log (P)$ dB.

For LTE Band 14

For operations in the 758-775 MHz and 788-805 MHz bands, all emissions including harmonics in the band 1559–1610 MHz shall be limited to -70 dBW/MHz equivalent isotropically radiated power (EIRP) for wideband signals, and -80 dBW EIRP for discrete emissions of less than 700 Hz bandwidth. For the purpose of equipment authorization, a transmitter shall be tested with an antenna that is representative of the type that will be used with the equipment in normal operation.

The spectrum is scanned from 30 MHz up to a frequency including its 10th harmonic.



4.2.2 Test Procedures

The testing follows FCC KDB 971168 D01 v03r01 Section 7 and ANSI / TIA-603-E Section 2.2.12.

1. The EUT was placed on a turntable with 0.8 meter for frequency below 1GHz and 1.5 meter for frequency above 1GHz respectively above ground.
2. The EUT was set 3 meters from the receiving antenna, which was mounted on the antenna tower.
3. The table was rotated 360 degrees to determine the position of the highest spurious emission.
4. The height of the receiving antenna is varied between one meter and four meters to search the maximum spurious emission for both horizontal and vertical polarizations.
5. Make the measurement with the spectrum analyzer's RBW = 1MHz, VBW = 3MHz, taking the record of maximum spurious emission.
6. A horn antenna was substituted in place of the EUT and was driven by a signal generator.
7. Tune the output power of signal generator to the same emission level with EUT maximum spurious emission.
8. Taking the record of output power at antenna port.
9. Repeat step 7 to step 8 for another polarization.
10. The RF fundamental frequency should be excluded against the limit line in the operating frequency band.

The limit line is derived from $43 + 10\log(P)$ dB below the transmitter power P(Watts)
For LTE Band 30

The limit line is derived from $70 + 10\log(P)$ dB below the transmitter power P(Watts)
For LTE Band 7, 38, 41

The limit line is derived from $55 + 10\log(P)$ dB below the transmitter power P(Watts)
 $EIRP \text{ (dBm)} = S.G. \text{ Power} - Tx \text{ Cable Loss} + Tx \text{ Antenna Gain}$

$ERP \text{ (dBm)} = EIRP - 2.15$



5 List of Measuring Equipment

| Instrument | Brand Name | Model No. | Serial No. | Characteristics | Calibration Date | Test Date | Due Date | Remark |
|---------------------------|-----------------|----------------------------|-----------------|----------------------|------------------|------------------------------|---------------|-----------------------|
| Bilog Antenna | Schaffner | CBL 6111C & N-6-06 | 2725 & AT-N0601 | 30MHz~1GHz | Nov. 06, 2022 | Nov. 29, 2022~ Jan. 05, 2023 | Nov. 05, 2023 | Radiation (03CH07-HY) |
| Bilog Antenna | TESEQ | CBL 6111D & 00800N1D01N-06 | 35419 & 03 | 30MHz~1GHz | Apr. 24, 2022 | Nov. 29, 2022~ Jan. 05, 2023 | Apr. 23, 2023 | Radiation (03CH07-HY) |
| Double Ridge Horn Antenna | ESCO | 3117 | 00227856 | 1GHz ~ 18GHz | Dec. 01, 2022 | Dec. 14, 2022~ Jan. 05, 2023 | Nov. 30, 2023 | Radiation (03CH07-HY) |
| Double Ridge Horn Antenna | ESCO | 3117 | 00227856 | 1GHz ~ 18GHz | Sep. 27, 2022 | Nov. 29, 2022~ Dec. 14, 2022 | Sep. 26, 2023 | Radiation (03CH07-HY) |
| Loop Antenna | Rohde & Schwarz | HFH2-Z2 | 100315 | 9 kHz~30 MHz | Jan. 07, 2022 | Nov. 29, 2022~ Jan. 05, 2023 | Jan. 06, 2023 | Radiation (03CH07-HY) |
| Preamplifier | MITEQ | AMF-7D-0010 1800-30-10P | 1590075 | 1GHz~18GHz | Apr. 21, 2022 | Nov. 29, 2022~ Jan. 05, 2023 | Apr. 20, 2023 | Radiation (03CH07-HY) |
| Preamplifier | COM-POWER | PA-103A | 161241 | 10MHz~1GHz | Oct. 03, 2022 | Nov. 29, 2022~ Jan. 05, 2023 | Oct. 02, 2023 | Radiation (03CH07-HY) |
| Preamplifier | Agilent | 8449B | 3008A02362 | 1GHz~26.5GHz | Oct. 03, 2022 | Nov. 29, 2022~ Jan. 05, 2023 | Oct. 02, 2023 | Radiation (03CH07-HY) |
| Preamplifier | EMEC | EM18G40G | 0600789 | 18-40GHz | Jul. 21, 2022 | Nov. 29, 2022~ Jan. 05, 2023 | Jul. 20, 2023 | Radiation (03CH07-HY) |
| Spectrum Analyzer | Agilent | N9030A | MY52350276 | 3Hz~44GHz | Jul. 22, 2022 | Nov. 29, 2022~ Jan. 05, 2023 | Jul. 21, 2023 | Radiation (03CH07-HY) |
| RF Cable | HUBER + SUHNER | SUCOFLEX 104 | MY15682/4 | 30MHz to 18GHz | Feb. 23, 2022 | Nov. 29, 2022~ Jan. 05, 2023 | Feb. 22, 2023 | Radiation (03CH07-HY) |
| RF Cable | HUBER + SUHNER | SUCOFLEX 104 | MY24971/4 | 9kHz to 18GHz | Feb. 23, 2022 | Nov. 29, 2022~ Jan. 05, 2023 | Feb. 22, 2023 | Radiation (03CH07-HY) |
| RF Cable | HUBER + SUHNER | SUCOFLEX 104 | MY28655/4 | 9kHz to 18GHz | Feb. 23, 2022 | Nov. 29, 2022~ Jan. 05, 2023 | Feb. 22, 2023 | Radiation (03CH07-HY) |
| RF Cable | HUBER + SUHNER | SUCOFLEX 126 | 532078/126E | 30MHz~18GHz | Sep. 16, 2022 | Nov. 29, 2022~ Jan. 05, 2023 | Sep. 15, 2023 | Radiation (03CH07-HY) |
| RF Cable | HUBER + SUHNER | SUCOFLEX 102 | MY2858/2 | 18GHz~40GHz | Feb. 23, 2022 | Nov. 29, 2022~ Jan. 05, 2023 | Feb. 22, 2023 | Radiation (03CH07-HY) |
| RF Cable | HUBER + SUHNER | SUCOFLEX 102 | 801606/2 | 9KHz ~ 40GHz | Apr. 14, 2022 | Nov. 29, 2022~ Jan. 05, 2023 | Apr. 13, 2023 | Radiation (03CH07-HY) |
| Controller | EMEC | EM1000 | N/A | Control Ant Mast | N/A | Nov. 29, 2022~ Jan. 05, 2023 | N/A | Radiation (03CH07-HY) |
| Controller | MF | MF-7802 | N/A | Control Turn table | N/A | Nov. 29, 2022~ Jan. 05, 2023 | N/A | Radiation (03CH07-HY) |
| Antenna Mast | EMEC | AM-BS-4500E | N/A | Boresight mast 1M~4M | N/A | Nov. 29, 2022~ Jan. 05, 2023 | N/A | Radiation (03CH07-HY) |
| Turn Table | ChainTek | Chaintek 3000 | N/A | 0~360 Degree | N/A | Nov. 29, 2022~ Jan. 05, 2023 | N/A | Radiation (03CH07-HY) |
| Software | Audix | E3 | N/A | N/A | N/A | Nov. 29, 2022~ Jan. 05, 2023 | N/A | Radiation (03CH07-HY) |
| USB Data Logger | TECPEL | TR-32 | HE17XB2495 | N/A | Mar. 07, 2022 | Nov. 29, 2022~ Jan. 05, 2023 | Mar. 06, 2023 | Radiation (03CH07-HY) |
| EMI Test Receiver | Agilent | N9038A(MXE) | MY53290045 | 20MHz~8.4GHz | Jan. 13, 2022 | Nov. 29, 2022~ Jan. 05, 2023 | Jan. 12, 2023 | Radiation (03CH07-HY) |
| SHF-EHF Horn Antenna | SCHWARZBECK | BBHA9170 | 00993 | 18GHz-40GHz | Nov. 24, 2022 | Nov. 29, 2022~ Jan. 05, 2023 | Nov. 23, 2023 | Radiation (03CH07-HY) |
| Horn Antenna | ETS-Lindgren | 3117 | 00143261 | 1GHz~18GHz | Feb. 11, 2022 | Nov. 29, 2022~ Jan. 05, 2023 | Feb. 10, 2023 | Radiation (03CH07-HY) |
| SHF-EHF Horn Antenna | SCHWARZBECK | BBHA 9170 | BBHA9170251 | 18GHz~40GHz | Nov. 24, 2022 | Nov. 29, 2022~ Jan. 05, 2023 | Nov. 23, 2023 | Radiation (03CH07-HY) |
| Signal Generator | Anritsu | MG3694C | 163401 | 8MHz~40GHz | Feb. 13, 2022 | Nov. 29, 2022~ Jan. 05, 2023 | Feb. 12, 2023 | Radiation (03CH07-HY) |



| Instrument | Brand Name | Model No. | Serial No. | Characteristics | Calibration Date | Test Date | Due Date | Remark |
|------------------------------|-----------------|-----------|------------|-------------------------------------|------------------|---------------------------------|---------------|---------------------|
| Radio Communication Analyzer | Anritsu | MT8821C | 6262025353 | LTE FDD/TDD LTE-2CC DLCA/ULCA | Oct. 13, 2022 | Nov. 25, 2022~ Jan. 18, 2023 | Oct. 12, 2023 | Conducted (TH03-HY) |
| Spectrum Analyzer | Rohde & Schwarz | FSV40 | 101908 | 10Hz~40GHz | Sep. 27, 2022 | Nov. 25, 2022~ Jan. 18, 2023 | Sep. 26, 2023 | Conducted (TH03-HY) |
| Thermal Chamber | ESPEC | SH-641 | 92013720 | -40°C ~90°C | Sep. 07, 2022 | Nov. 25, 2022~ Jan. 18, 2023 | Sep. 06, 2023 | Conducted (TH03-HY) |
| DC Power Supply | GW Instek | GPP-2323 | GET861546 | 0V~64V ; 0A~6A | Jun. 24, 2022 | Nov. 25, 2022~ Jan. 18, 2023 | Jun. 23, 2023 | Conducted (TH03-HY) |
| Coupler | MVE | MVE4816 | A400014 | 0.5~18GHz | May 09, 2022 | Nov. 25, 2022~ Jan. 18, 2023 | May 08, 2023 | Conducted (TH03-HY) |



6 Uncertainty of Evaluation

Uncertainty of Radiated Emission Measurement (30 MHz ~ 1000 MHz)

| | |
|---|---------|
| Measuring Uncertainty for a Level of Confidence of 95% ($U = 2Uc(y)$) | 3.25 dB |
|---|---------|

Uncertainty of Radiated Emission Measurement (1 GHz ~ 18 GHz)

| | |
|---|---------|
| Measuring Uncertainty for a Level of Confidence of 95% ($U = 2Uc(y)$) | 3.50 dB |
|---|---------|

Uncertainty of Radiated Emission Measurement (18 GHz ~ 40 GHz)

| | |
|---|---------|
| Measuring Uncertainty for a Level of Confidence of 95% ($U = 2Uc(y)$) | 4.08 dB |
|---|---------|



Appendix A. Test Results of Conducted Test

Conducted Output Power(Average power & ERP/EIRP)

<Primary Antenna>

| LTE Band 2 Maximum Average Power [dBm] (GT - LC = -0.25 dB) | | | | | | | | |
|---|-----------|-----------|---------|--------|--------|---------|------------|----------|
| BW [MHz] | RB Size | RB Offset | Mod | Lowest | Middle | Highest | EIRP (dBm) | EIRP (W) |
| 20 | 1 | 0 | QPSK | 24.39 | 24.69 | 24.50 | 24.44 | 0.2780 |
| 20 | 1 | 49 | | 24.54 | 24.48 | 24.52 | | |
| 20 | 1 | 99 | | 24.34 | 24.15 | 24.48 | | |
| 20 | 50 | 0 | | 23.47 | 23.57 | 23.50 | | |
| 20 | 50 | 24 | | 23.45 | 23.45 | 23.48 | | |
| 20 | 50 | 50 | | 23.44 | 23.29 | 23.48 | | |
| 20 | 100 | 0 | | 23.46 | 23.51 | 23.44 | | |
| 20 | 1 | 0 | 16-QAM | 23.65 | 24.11 | 23.76 | 23.86 | 0.2432 |
| 20 | 1 | 49 | | 23.83 | 23.81 | 23.84 | | |
| 20 | 1 | 99 | | 23.71 | 23.53 | 23.88 | | |
| 20 | 50 | 0 | | 22.46 | 22.62 | 22.47 | | |
| 20 | 50 | 24 | | 22.49 | 22.49 | 22.48 | | |
| 20 | 50 | 50 | | 22.45 | 22.33 | 22.54 | | |
| 20 | 100 | 0 | | 22.45 | 22.46 | 22.50 | | |
| 20 | 1 | 0 | 64-QAM | 22.44 | 22.84 | 22.73 | 22.59 | 0.1816 |
| 20 | 1 | 49 | | 22.59 | 22.52 | 22.65 | | |
| 20 | 1 | 99 | | 22.55 | 22.26 | 22.69 | | |
| 20 | 50 | 0 | | 21.49 | 21.65 | 21.51 | | |
| 20 | 50 | 24 | | 21.52 | 21.55 | 21.51 | | |
| 20 | 50 | 50 | | 21.49 | 21.38 | 21.57 | | |
| 20 | 100 | 0 | | 21.45 | 21.48 | 21.50 | | |
| 20 | 1 | 0 | 256-QAM | 19.73 | 19.89 | 19.75 | 19.64 | 0.0920 |
| 20 | 1 | 49 | | 19.47 | 19.65 | 19.49 | | |
| 20 | 1 | 99 | | 19.17 | 19.43 | 19.19 | | |
| 20 | 50 | 0 | | 19.66 | 19.85 | 19.69 | | |
| 20 | 50 | 24 | | 19.53 | 19.70 | 19.52 | | |
| 20 | 50 | 50 | | 19.34 | 19.57 | 19.34 | | |
| 20 | 100 | 0 | | 19.43 | 19.66 | 19.50 | | |
| Limit | EIRP < 2W | | | Result | | | Pass | |



| LTE Band 2 Maximum Average Power [dBm] (GT - LC = -0.25 dB) | | | | | | | | |
|---|-----------|-----------|---------|--------|--------|---------|------------|----------|
| BW [MHz] | RB Size | RB Offset | Mod | Lowest | Middle | Highest | EIRP (dBm) | EIRP (W) |
| 15 | 1 | 0 | QPSK | 24.20 | 24.53 | 24.30 | 24.28 | 0.2679 |
| 15 | 1 | 37 | | 24.45 | 24.28 | 24.33 | | |
| 15 | 1 | 74 | | 24.17 | 24.07 | 24.35 | | |
| 15 | 36 | 0 | | 23.34 | 23.47 | 23.33 | | |
| 15 | 36 | 20 | | 23.37 | 23.35 | 23.28 | | |
| 15 | 36 | 39 | | 23.39 | 23.28 | 23.46 | | |
| 15 | 75 | 0 | | 23.35 | 23.32 | 23.26 | | |
| 15 | 1 | 0 | 16-QAM | 23.45 | 23.98 | 23.73 | 23.73 | 0.2360 |
| 15 | 1 | 37 | | 23.65 | 23.80 | 23.73 | | |
| 15 | 1 | 74 | | 23.52 | 23.41 | 23.86 | | |
| 15 | 36 | 0 | | 22.44 | 22.49 | 22.34 | | |
| 15 | 36 | 20 | | 22.47 | 22.36 | 22.40 | | |
| 15 | 36 | 39 | | 22.28 | 22.31 | 22.39 | | |
| 15 | 75 | 0 | | 22.28 | 22.33 | 22.37 | | |
| 15 | 1 | 0 | 64-QAM | 22.30 | 22.74 | 22.59 | 22.49 | 0.1774 |
| 15 | 1 | 37 | | 22.46 | 22.49 | 22.64 | | |
| 15 | 1 | 74 | | 22.43 | 22.08 | 22.52 | | |
| 15 | 36 | 0 | | 21.33 | 21.64 | 21.40 | | |
| 15 | 36 | 20 | | 21.34 | 21.51 | 21.50 | | |
| 15 | 36 | 39 | | 21.41 | 21.21 | 21.54 | | |
| 15 | 75 | 0 | | 21.26 | 21.31 | 21.36 | | |
| 15 | 1 | 0 | 256-QAM | 19.54 | 19.69 | 19.56 | 19.44 | 0.0879 |
| 15 | 1 | 37 | | 19.37 | 19.60 | 19.31 | | |
| 15 | 1 | 74 | | 19.17 | 19.36 | 19.02 | | |
| 15 | 36 | 0 | | 19.47 | 19.69 | 19.62 | | |
| 15 | 36 | 20 | | 19.44 | 19.64 | 19.47 | | |
| 15 | 36 | 39 | | 19.15 | 19.51 | 19.23 | | |
| 15 | 75 | 0 | | 19.36 | 19.66 | 19.35 | | |
| Limit | EIRP < 2W | | | Result | | | Pass | |



| LTE Band 2 Maximum Average Power [dBm] (GT - LC = -0.25 dB) | | | | | | | | |
|---|-----------|-----------|---------|--------|--------|---------|------------|----------|
| BW [MHz] | RB Size | RB Offset | Mod | Lowest | Middle | Highest | EIRP (dBm) | EIRP (W) |
| 10 | 1 | 0 | QPSK | 24.36 | 24.58 | 24.40 | 24.33 | 0.2710 |
| 10 | 1 | 25 | | 24.45 | 24.37 | 24.35 | | |
| 10 | 1 | 49 | | 24.23 | 24.13 | 24.40 | | |
| 10 | 25 | 0 | | 23.45 | 23.42 | 23.35 | | |
| 10 | 25 | 12 | | 23.32 | 23.40 | 23.44 | | |
| 10 | 25 | 25 | | 23.29 | 23.19 | 23.29 | | |
| 10 | 50 | 0 | | 23.30 | 23.33 | 23.35 | | |
| 10 | 1 | 0 | 16-QAM | 23.49 | 23.91 | 23.74 | 23.66 | 0.2323 |
| 10 | 1 | 25 | | 23.67 | 23.69 | 23.68 | | |
| 10 | 1 | 49 | | 23.70 | 23.38 | 23.70 | | |
| 10 | 25 | 0 | | 22.40 | 22.59 | 22.43 | | |
| 10 | 25 | 12 | | 22.31 | 22.41 | 22.39 | | |
| 10 | 25 | 25 | | 22.25 | 22.33 | 22.49 | | |
| 10 | 50 | 0 | | 22.26 | 22.27 | 22.49 | | |
| 10 | 1 | 0 | 64-QAM | 22.32 | 22.80 | 22.54 | 22.55 | 0.1799 |
| 10 | 1 | 25 | | 22.51 | 22.44 | 22.52 | | |
| 10 | 1 | 49 | | 22.42 | 22.07 | 22.54 | | |
| 10 | 25 | 0 | | 21.46 | 21.54 | 21.51 | | |
| 10 | 25 | 12 | | 21.32 | 21.48 | 21.51 | | |
| 10 | 25 | 25 | | 21.35 | 21.31 | 21.43 | | |
| 10 | 50 | 0 | | 21.41 | 21.35 | 21.50 | | |
| 10 | 1 | 0 | 256-QAM | 19.73 | 19.88 | 19.57 | 19.63 | 0.0918 |
| 10 | 1 | 25 | | 19.34 | 19.63 | 19.33 | | |
| 10 | 1 | 49 | | 18.98 | 19.36 | 19.18 | | |
| 10 | 25 | 0 | | 19.66 | 19.81 | 19.51 | | |
| 10 | 25 | 12 | | 19.33 | 19.50 | 19.33 | | |
| 10 | 25 | 25 | | 19.20 | 19.40 | 19.25 | | |
| 10 | 50 | 0 | | 19.26 | 19.49 | 19.31 | | |
| Limit | EIRP < 2W | | | Result | | | Pass | |



| LTE Band 2 Maximum Average Power [dBm] (GT - LC = -0.25 dB) | | | | | | | | |
|---|-----------|-----------|---------|--------|--------|---------|------------|----------|
| BW [MHz] | RB Size | RB Offset | Mod | Lowest | Middle | Highest | EIRP (dBm) | EIRP (W) |
| 5 | 1 | 0 | QPSK | 24.36 | 24.60 | 24.39 | 24.35 | 0.2723 |
| 5 | 1 | 12 | | 24.37 | 24.47 | 24.52 | | |
| 5 | 1 | 24 | | 24.23 | 23.96 | 24.41 | | |
| 5 | 12 | 0 | | 23.33 | 23.54 | 23.32 | | |
| 5 | 12 | 7 | | 23.39 | 23.43 | 23.33 | | |
| 5 | 12 | 13 | | 23.32 | 23.13 | 23.40 | | |
| 5 | 25 | 0 | | 23.28 | 23.40 | 23.43 | | |
| 5 | 1 | 0 | 16-QAM | 23.52 | 24.08 | 23.57 | 23.83 | 0.2415 |
| 5 | 1 | 12 | | 23.81 | 23.73 | 23.69 | | |
| 5 | 1 | 24 | | 23.55 | 23.37 | 23.68 | | |
| 5 | 12 | 0 | | 22.28 | 22.53 | 22.43 | | |
| 5 | 12 | 7 | | 22.41 | 22.37 | 22.34 | | |
| 5 | 12 | 13 | | 22.43 | 22.23 | 22.43 | | |
| 5 | 25 | 0 | | 22.35 | 22.33 | 22.37 | | |
| 5 | 1 | 0 | 64-QAM | 22.28 | 22.84 | 22.69 | 22.59 | 0.1816 |
| 5 | 1 | 12 | | 22.59 | 22.41 | 22.50 | | |
| 5 | 1 | 24 | | 22.44 | 22.22 | 22.63 | | |
| 5 | 12 | 0 | | 21.47 | 21.57 | 21.44 | | |
| 5 | 12 | 7 | | 21.49 | 21.42 | 21.42 | | |
| 5 | 12 | 13 | | 21.41 | 21.32 | 21.45 | | |
| 5 | 25 | 0 | | 21.26 | 21.36 | 21.36 | | |
| 5 | 1 | 0 | 256-QAM | 19.54 | 19.77 | 19.62 | 19.52 | 0.0895 |
| 5 | 1 | 12 | | 19.42 | 19.61 | 19.32 | | |
| 5 | 1 | 24 | | 19.11 | 19.27 | 19.02 | | |
| 5 | 12 | 0 | | 19.53 | 19.66 | 19.61 | | |
| 5 | 12 | 7 | | 19.52 | 19.67 | 19.47 | | |
| 5 | 12 | 13 | | 19.25 | 19.45 | 19.14 | | |
| 5 | 25 | 0 | | 19.36 | 19.63 | 19.33 | | |
| Limit | EIRP < 2W | | | Result | | | Pass | |



| LTE Band 2 Maximum Average Power [dBm] (GT - LC = -0.25 dB) | | | | | | | | |
|---|-----------|-----------|---------|--------|--------|---------|------------|----------|
| BW [MHz] | RB Size | RB Offset | Mod | Lowest | Middle | Highest | EIRP (dBm) | EIRP (W) |
| 3 | 1 | 0 | QPSK | 24.24 | 24.53 | 24.43 | 24.28 | 0.2679 |
| 3 | 1 | 8 | | 24.39 | 24.36 | 24.45 | | |
| 3 | 1 | 14 | | 24.33 | 24.02 | 24.41 | | |
| 3 | 8 | 0 | | 23.46 | 23.54 | 23.46 | | |
| 3 | 8 | 4 | | 23.34 | 23.45 | 23.31 | | |
| 3 | 8 | 7 | | 23.44 | 23.09 | 23.47 | | |
| 3 | 15 | 0 | | 23.37 | 23.50 | 23.40 | | |
| 3 | 1 | 0 | 16-QAM | 23.50 | 23.98 | 23.63 | 23.73 | 0.2360 |
| 3 | 1 | 8 | | 23.82 | 23.72 | 23.69 | | |
| 3 | 1 | 14 | | 23.57 | 23.39 | 23.80 | | |
| 3 | 8 | 0 | | 22.28 | 22.56 | 22.40 | | |
| 3 | 8 | 4 | | 22.44 | 22.34 | 22.48 | | |
| 3 | 8 | 7 | | 22.36 | 22.29 | 22.36 | | |
| 3 | 15 | 0 | | 22.30 | 22.37 | 22.37 | | |
| 3 | 1 | 0 | 64-QAM | 22.37 | 22.82 | 22.61 | 22.57 | 0.1807 |
| 3 | 1 | 8 | | 22.48 | 22.43 | 22.63 | | |
| 3 | 1 | 14 | | 22.48 | 22.24 | 22.67 | | |
| 3 | 8 | 0 | | 21.44 | 21.47 | 21.34 | | |
| 3 | 8 | 4 | | 21.38 | 21.46 | 21.51 | | |
| 3 | 8 | 7 | | 21.49 | 21.24 | 21.42 | | |
| 3 | 15 | 0 | | 21.38 | 21.37 | 21.37 | | |
| 3 | 1 | 0 | 256-QAM | 19.58 | 19.74 | 19.67 | 19.49 | 0.0889 |
| 3 | 1 | 8 | | 19.37 | 19.51 | 19.37 | | |
| 3 | 1 | 14 | | 18.98 | 19.27 | 19.05 | | |
| 3 | 8 | 0 | | 19.65 | 19.71 | 19.55 | | |
| 3 | 8 | 4 | | 19.35 | 19.67 | 19.50 | | |
| 3 | 8 | 7 | | 19.14 | 19.37 | 19.25 | | |
| 3 | 15 | 0 | | 19.36 | 19.57 | 19.40 | | |
| Limit | EIRP < 2W | | | Result | | | Pass | |



| LTE Band 2 Maximum Average Power [dBm] (GT - LC = -0.25 dB) | | | | | | | | |
|---|-----------|-----------|---------|--------|--------|---------|------------|----------|
| BW [MHz] | RB Size | RB Offset | Mod | Lowest | Middle | Highest | EIRP (dBm) | EIRP (W) |
| 1.4 | 1 | 0 | QPSK | 24.22 | 24.67 | 24.36 | 24.42 | 0.2767 |
| 1.4 | 1 | 3 | | 24.37 | 24.42 | 24.44 | | |
| 1.4 | 1 | 5 | | 24.15 | 24.15 | 24.35 | | |
| 1.4 | 3 | 0 | | 24.33 | 24.56 | 24.38 | | |
| 1.4 | 3 | 1 | | 24.41 | 24.43 | 24.52 | | |
| 1.4 | 3 | 3 | | 24.34 | 24.11 | 24.42 | | |
| 1.4 | 6 | 0 | | 23.42 | 23.54 | 23.41 | | |
| 1.4 | 1 | 0 | 16-QAM | 23.39 | 23.28 | 23.44 | 23.74 | 0.2366 |
| 1.4 | 1 | 3 | | 23.27 | 23.09 | 23.32 | | |
| 1.4 | 1 | 5 | | 23.30 | 23.45 | 23.28 | | |
| 1.4 | 3 | 0 | | 23.60 | 23.99 | 23.60 | | |
| 1.4 | 3 | 1 | | 23.67 | 23.61 | 23.69 | | |
| 1.4 | 3 | 3 | | 23.60 | 23.35 | 23.76 | | |
| 1.4 | 6 | 0 | | 22.44 | 22.62 | 22.27 | | |
| 1.4 | 1 | 0 | 64-QAM | 22.38 | 22.30 | 22.35 | 22.45 | 0.1758 |
| 1.4 | 1 | 3 | | 22.40 | 22.19 | 22.46 | | |
| 1.4 | 1 | 5 | | 22.37 | 22.31 | 22.42 | | |
| 1.4 | 3 | 0 | | 22.32 | 22.70 | 22.63 | | |
| 1.4 | 3 | 1 | | 22.44 | 22.38 | 22.65 | | |
| 1.4 | 3 | 3 | | 22.41 | 22.25 | 22.66 | | |
| 1.4 | 6 | 0 | | 21.47 | 21.57 | 21.32 | | |
| 1.4 | 1 | 0 | 256-QAM | 19.69 | 19.79 | 19.62 | 19.54 | 0.0899 |
| 1.4 | 1 | 3 | | 19.39 | 19.54 | 19.31 | | |
| 1.4 | 1 | 5 | | 19.07 | 19.41 | 19.11 | | |
| 1.4 | 3 | 0 | | 19.47 | 19.70 | 19.69 | | |
| 1.4 | 3 | 1 | | 19.35 | 19.65 | 19.35 | | |
| 1.4 | 3 | 3 | | 19.20 | 19.44 | 19.23 | | |
| 1.4 | 6 | 0 | | 19.33 | 19.53 | 19.30 | | |
| Limit | EIRP < 2W | | | Result | | | Pass | |



| LTE Band 25 Maximum Average Power [dBm] (GT - LC = -0.25 dB) | | | | | | | | |
|--|-----------|-----------|---------|--------|--------|---------|------------|----------|
| BW [MHz] | RB Size | RB Offset | Mod | Lowest | Middle | Highest | EIRP (dBm) | EIRP (W) |
| 20 | 1 | 0 | QPSK | 24.40 | 24.72 | 24.50 | 24.47 | 0.2799 |
| 20 | 1 | 49 | | 24.27 | 24.45 | 24.44 | | |
| 20 | 1 | 99 | | 24.23 | 24.13 | 24.40 | | |
| 20 | 50 | 0 | | 23.50 | 23.69 | 23.52 | | |
| 20 | 50 | 24 | | 23.47 | 23.57 | 23.48 | | |
| 20 | 50 | 50 | | 23.44 | 23.42 | 23.49 | | |
| 20 | 100 | 0 | | 23.45 | 23.53 | 23.50 | | |
| 20 | 1 | 0 | 16-QAM | 23.62 | 24.00 | 23.69 | 23.75 | 0.2371 |
| 20 | 1 | 49 | | 23.65 | 23.77 | 23.73 | | |
| 20 | 1 | 99 | | 23.64 | 23.49 | 23.85 | | |
| 20 | 50 | 0 | | 22.46 | 22.67 | 22.41 | | |
| 20 | 50 | 24 | | 22.52 | 22.53 | 22.51 | | |
| 20 | 50 | 50 | | 22.50 | 22.37 | 22.63 | | |
| 20 | 100 | 0 | | 22.47 | 22.53 | 22.51 | | |
| 20 | 1 | 0 | 64-QAM | 22.72 | 22.90 | 22.76 | 22.68 | 0.1854 |
| 20 | 1 | 49 | | 22.73 | 22.61 | 22.83 | | |
| 20 | 1 | 99 | | 22.70 | 22.40 | 22.93 | | |
| 20 | 50 | 0 | | 21.57 | 21.71 | 21.50 | | |
| 20 | 50 | 24 | | 21.57 | 21.57 | 21.56 | | |
| 20 | 50 | 50 | | 21.55 | 21.42 | 21.65 | | |
| 20 | 100 | 0 | | 21.51 | 21.53 | 21.56 | | |
| 20 | 1 | 0 | 256-QAM | 19.12 | 19.68 | 19.25 | 19.43 | 0.0877 |
| 20 | 1 | 49 | | 18.82 | 19.48 | 19.04 | | |
| 20 | 1 | 99 | | 18.75 | 19.38 | 18.87 | | |
| 20 | 50 | 0 | | 18.80 | 19.42 | 18.93 | | |
| 20 | 50 | 24 | | 18.75 | 19.31 | 18.85 | | |
| 20 | 50 | 50 | | 18.75 | 19.35 | 18.92 | | |
| 20 | 100 | 0 | | 18.78 | 19.37 | 18.92 | | |
| Limit | EIRP < 2W | | | Result | | | Pass | |



| LTE Band 25 Maximum Average Power [dBm] (GT - LC = -0.25 dB) | | | | | | | | |
|--|-----------|-----------|---------|--------|--------|---------|------------|----------|
| BW [MHz] | RB Size | RB Offset | Mod | Lowest | Middle | Highest | EIRP (dBm) | EIRP (W) |
| 15 | 1 | 0 | QPSK | 24.36 | 24.57 | 24.44 | 24.32 | 0.2704 |
| 15 | 1 | 37 | | 24.21 | 24.37 | 24.39 | | |
| 15 | 1 | 74 | | 24.07 | 23.93 | 24.20 | | |
| 15 | 36 | 0 | | 23.36 | 23.66 | 23.49 | | |
| 15 | 36 | 20 | | 23.29 | 23.40 | 23.42 | | |
| 15 | 36 | 39 | | 23.24 | 23.27 | 23.45 | | |
| 15 | 75 | 0 | | 23.44 | 23.41 | 23.46 | | |
| 15 | 1 | 0 | 16-QAM | 23.60 | 23.80 | 23.61 | 23.55 | 0.2265 |
| 15 | 1 | 37 | | 23.46 | 23.57 | 23.72 | | |
| 15 | 1 | 74 | | 23.47 | 23.43 | 23.75 | | |
| 15 | 36 | 0 | | 22.35 | 22.61 | 22.27 | | |
| 15 | 36 | 20 | | 22.33 | 22.50 | 22.38 | | |
| 15 | 36 | 39 | | 22.31 | 22.32 | 22.55 | | |
| 15 | 75 | 0 | | 22.47 | 22.47 | 22.43 | | |
| 15 | 1 | 0 | 64-QAM | 22.65 | 22.81 | 22.67 | 22.60 | 0.1820 |
| 15 | 1 | 37 | | 22.67 | 22.45 | 22.66 | | |
| 15 | 1 | 74 | | 22.69 | 22.26 | 22.85 | | |
| 15 | 36 | 0 | | 21.55 | 21.61 | 21.38 | | |
| 15 | 36 | 20 | | 21.54 | 21.55 | 21.46 | | |
| 15 | 36 | 39 | | 21.45 | 21.24 | 21.64 | | |
| 15 | 75 | 0 | | 21.35 | 21.44 | 21.49 | | |
| 15 | 1 | 0 | 256-QAM | 19.08 | 19.48 | 19.08 | 19.23 | 0.0838 |
| 15 | 1 | 37 | | 18.72 | 19.31 | 18.87 | | |
| 15 | 1 | 74 | | 18.71 | 19.26 | 18.81 | | |
| 15 | 36 | 0 | | 18.72 | 19.37 | 18.84 | | |
| 15 | 36 | 20 | | 18.72 | 19.18 | 18.82 | | |
| 15 | 36 | 39 | | 18.73 | 19.15 | 18.75 | | |
| 15 | 75 | 0 | | 18.70 | 19.24 | 18.74 | | |
| Limit | EIRP < 2W | | | Result | | | Pass | |



| LTE Band 25 Maximum Average Power [dBm] (GT - LC = -0.25 dB) | | | | | | | | |
|--|-----------|-----------|---------|--------|--------|---------|------------|----------|
| BW [MHz] | RB Size | RB Offset | Mod | Lowest | Middle | Highest | EIRP (dBm) | EIRP (W) |
| 10 | 1 | 0 | QPSK | 24.27 | 24.56 | 24.50 | 24.31 | 0.2698 |
| 10 | 1 | 25 | | 24.23 | 24.27 | 24.32 | | |
| 10 | 1 | 49 | | 24.20 | 23.96 | 24.39 | | |
| 10 | 25 | 0 | | 23.42 | 23.50 | 23.36 | | |
| 10 | 25 | 12 | | 23.42 | 23.55 | 23.46 | | |
| 10 | 25 | 25 | | 23.36 | 23.39 | 23.29 | | |
| 10 | 50 | 0 | | 23.38 | 23.41 | 23.44 | | |
| 10 | 1 | 0 | 16-QAM | 23.50 | 23.90 | 23.66 | 23.65 | 0.2317 |
| 10 | 1 | 25 | | 23.48 | 23.67 | 23.57 | | |
| 10 | 1 | 49 | | 23.49 | 23.32 | 23.73 | | |
| 10 | 25 | 0 | | 22.37 | 22.58 | 22.25 | | |
| 10 | 25 | 12 | | 22.34 | 22.33 | 22.47 | | |
| 10 | 25 | 25 | | 22.31 | 22.30 | 22.45 | | |
| 10 | 50 | 0 | | 22.29 | 22.48 | 22.43 | | |
| 10 | 1 | 0 | 64-QAM | 22.63 | 22.77 | 22.68 | 22.57 | 0.1807 |
| 10 | 1 | 25 | | 22.61 | 22.57 | 22.69 | | |
| 10 | 1 | 49 | | 22.61 | 22.29 | 22.82 | | |
| 10 | 25 | 0 | | 21.53 | 21.59 | 21.30 | | |
| 10 | 25 | 12 | | 21.45 | 21.50 | 21.41 | | |
| 10 | 25 | 25 | | 21.39 | 21.30 | 21.55 | | |
| 10 | 50 | 0 | | 21.34 | 21.43 | 21.43 | | |
| 10 | 1 | 0 | 256-QAM | 19.02 | 19.57 | 19.25 | 19.32 | 0.0855 |
| 10 | 1 | 25 | | 18.72 | 19.34 | 18.91 | | |
| 10 | 1 | 49 | | 18.72 | 19.23 | 18.76 | | |
| 10 | 25 | 0 | | 18.78 | 19.32 | 18.84 | | |
| 10 | 25 | 12 | | 18.78 | 19.30 | 18.84 | | |
| 10 | 25 | 25 | | 18.79 | 19.19 | 18.84 | | |
| 10 | 50 | 0 | | 18.70 | 19.37 | 18.85 | | |
| Limit | EIRP < 2W | | | Result | | | Pass | |



| LTE Band 25 Maximum Average Power [dBm] (GT - LC = -0.25 dB) | | | | | | | | |
|--|-----------|-----------|---------|--------|--------|---------|------------|----------|
| BW [MHz] | RB Size | RB Offset | Mod | Lowest | Middle | Highest | EIRP (dBm) | EIRP (W) |
| 5 | 1 | 0 | QPSK | 24.20 | 24.71 | 24.32 | 24.46 | 0.2793 |
| 5 | 1 | 12 | | 24.16 | 24.44 | 24.35 | | |
| 5 | 1 | 24 | | 24.20 | 24.08 | 24.35 | | |
| 5 | 12 | 0 | | 23.38 | 23.55 | 23.52 | | |
| 5 | 12 | 7 | | 23.40 | 23.51 | 23.39 | | |
| 5 | 12 | 13 | | 23.27 | 23.42 | 23.48 | | |
| 5 | 25 | 0 | | 23.42 | 23.35 | 23.42 | | |
| 5 | 1 | 0 | 16-QAM | 23.43 | 23.82 | 23.58 | 23.57 | 0.2275 |
| 5 | 1 | 12 | | 23.61 | 23.73 | 23.61 | | |
| 5 | 1 | 24 | | 23.64 | 23.33 | 23.82 | | |
| 5 | 12 | 0 | | 22.39 | 22.58 | 22.32 | | |
| 5 | 12 | 7 | | 22.37 | 22.41 | 22.51 | | |
| 5 | 12 | 13 | | 22.40 | 22.20 | 22.43 | | |
| 5 | 25 | 0 | | 22.46 | 22.47 | 22.50 | | |
| 5 | 1 | 0 | 64-QAM | 22.54 | 22.87 | 22.58 | 22.67 | 0.1849 |
| 5 | 1 | 12 | | 22.62 | 22.56 | 22.77 | | |
| 5 | 1 | 24 | | 22.68 | 22.26 | 22.92 | | |
| 5 | 12 | 0 | | 21.37 | 21.71 | 21.35 | | |
| 5 | 12 | 7 | | 21.40 | 21.41 | 21.39 | | |
| 5 | 12 | 13 | | 21.45 | 21.42 | 21.46 | | |
| 5 | 25 | 0 | | 21.36 | 21.40 | 21.52 | | |
| 5 | 1 | 0 | 256-QAM | 18.95 | 19.52 | 19.24 | 19.27 | 0.0845 |
| 5 | 1 | 12 | | 18.73 | 19.31 | 19.02 | | |
| 5 | 1 | 24 | | 18.71 | 19.18 | 18.81 | | |
| 5 | 12 | 0 | | 18.70 | 19.32 | 18.76 | | |
| 5 | 12 | 7 | | 18.72 | 19.22 | 18.74 | | |
| 5 | 12 | 13 | | 18.78 | 19.15 | 18.79 | | |
| 5 | 25 | 0 | | 18.73 | 19.27 | 18.89 | | |
| Limit | EIRP < 2W | | | Result | | | Pass | |



| LTE Band 25 Maximum Average Power [dBm] (GT - LC = -0.25 dB) | | | | | | | | |
|--|-----------|-----------|---------|--------|--------|---------|------------|----------|
| BW [MHz] | RB Size | RB Offset | Mod | Lowest | Middle | Highest | EIRP (dBm) | EIRP (W) |
| 3 | 1 | 0 | QPSK | 24.22 | 24.56 | 24.39 | 24.31 | 0.2698 |
| 3 | 1 | 8 | | 24.20 | 24.38 | 24.28 | | |
| 3 | 1 | 14 | | 24.15 | 24.00 | 24.27 | | |
| 3 | 8 | 0 | | 23.31 | 23.62 | 23.32 | | |
| 3 | 8 | 4 | | 23.37 | 23.40 | 23.29 | | |
| 3 | 8 | 7 | | 23.39 | 23.33 | 23.45 | | |
| 3 | 15 | 0 | | 23.41 | 23.51 | 23.48 | | |
| 3 | 1 | 0 | 16-QAM | 23.58 | 23.89 | 23.64 | 23.64 | 0.2312 |
| 3 | 1 | 8 | | 23.62 | 23.57 | 23.64 | | |
| 3 | 1 | 14 | | 23.64 | 23.48 | 23.85 | | |
| 3 | 8 | 0 | | 22.28 | 22.66 | 22.37 | | |
| 3 | 8 | 4 | | 22.35 | 22.42 | 22.37 | | |
| 3 | 8 | 7 | | 22.33 | 22.33 | 22.52 | | |
| 3 | 15 | 0 | | 22.46 | 22.46 | 22.46 | | |
| 3 | 1 | 0 | 64-QAM | 22.67 | 22.88 | 22.76 | 22.65 | 0.1841 |
| 3 | 1 | 8 | | 22.68 | 22.52 | 22.74 | | |
| 3 | 1 | 14 | | 22.63 | 22.26 | 22.90 | | |
| 3 | 8 | 0 | | 21.56 | 21.61 | 21.34 | | |
| 3 | 8 | 4 | | 21.38 | 21.43 | 21.43 | | |
| 3 | 8 | 7 | | 21.53 | 21.26 | 21.62 | | |
| 3 | 15 | 0 | | 21.39 | 21.36 | 21.36 | | |
| 3 | 1 | 0 | 256-QAM | 18.92 | 19.60 | 19.19 | 19.35 | 0.0861 |
| 3 | 1 | 8 | | 18.76 | 19.42 | 18.87 | | |
| 3 | 1 | 14 | | 18.71 | 19.23 | 18.75 | | |
| 3 | 8 | 0 | | 18.77 | 19.24 | 18.76 | | |
| 3 | 8 | 4 | | 18.71 | 19.29 | 18.83 | | |
| 3 | 8 | 7 | | 18.72 | 19.32 | 18.79 | | |
| 3 | 15 | 0 | | 18.70 | 19.30 | 18.86 | | |
| Limit | EIRP < 2W | | | Result | | | Pass | |



| LTE Band 25 Maximum Average Power [dBm] (GT - LC = -0.25 dB) | | | | | | | | |
|--|-----------|-----------|---------|--------|--------|---------|------------|----------|
| BW [MHz] | RB Size | RB Offset | Mod | Lowest | Middle | Highest | EIRP (dBm) | EIRP (W) |
| 1.4 | 1 | 0 | QPSK | 24.34 | 24.63 | 24.45 | 24.47 | 0.2799 |
| 1.4 | 1 | 3 | | 24.16 | 24.36 | 24.40 | | |
| 1.4 | 1 | 5 | | 24.20 | 23.94 | 24.37 | | |
| 1.4 | 3 | 0 | | 24.25 | 24.72 | 24.50 | | |
| 1.4 | 3 | 1 | | 24.13 | 24.26 | 24.30 | | |
| 1.4 | 3 | 3 | | 24.22 | 23.99 | 24.29 | | |
| 1.4 | 6 | 0 | | 23.49 | 23.63 | 23.47 | | |
| 1.4 | 1 | 0 | 16-QAM | 23.31 | 23.47 | 23.31 | 23.62 | 0.2301 |
| 1.4 | 1 | 3 | | 23.29 | 23.23 | 23.42 | | |
| 1.4 | 1 | 5 | | 23.40 | 23.53 | 23.42 | | |
| 1.4 | 3 | 0 | | 23.43 | 23.87 | 23.68 | | |
| 1.4 | 3 | 1 | | 23.55 | 23.63 | 23.63 | | |
| 1.4 | 3 | 3 | | 23.54 | 23.41 | 23.79 | | |
| 1.4 | 6 | 0 | | 22.39 | 22.53 | 22.23 | | |
| 1.4 | 1 | 0 | 64-QAM | 22.47 | 22.35 | 22.32 | 22.62 | 0.1828 |
| 1.4 | 1 | 3 | | 22.44 | 22.25 | 22.60 | | |
| 1.4 | 1 | 5 | | 22.30 | 22.46 | 22.39 | | |
| 1.4 | 3 | 0 | | 22.67 | 22.87 | 22.72 | | |
| 1.4 | 3 | 1 | | 22.67 | 22.54 | 22.70 | | |
| 1.4 | 3 | 3 | | 22.53 | 22.24 | 22.80 | | |
| 1.4 | 6 | 0 | | 21.57 | 21.66 | 21.42 | | |
| 1.4 | 1 | 0 | 256-QAM | 19.12 | 19.66 | 19.25 | 19.41 | 0.0873 |
| 1.4 | 1 | 3 | | 18.77 | 19.36 | 19.01 | | |
| 1.4 | 1 | 5 | | 18.72 | 19.23 | 18.77 | | |
| 1.4 | 3 | 0 | | 18.75 | 19.36 | 18.83 | | |
| 1.4 | 3 | 1 | | 18.72 | 19.20 | 18.78 | | |
| 1.4 | 3 | 3 | | 18.79 | 19.22 | 18.79 | | |
| 1.4 | 6 | 0 | | 18.75 | 19.32 | 18.72 | | |
| Limit | EIRP < 2W | | | Result | | | Pass | |



| LTE Band 4 Maximum Average Power [dBm] (GT - LC = -0.02 dB) | | | | | | | | |
|---|-----------|-----------|---------|--------|--------|---------|------------|----------|
| BW [MHz] | RB Size | RB Offset | Mod | Lowest | Middle | Highest | EIRP (dBm) | EIRP (W) |
| 20 | 1 | 0 | QPSK | 24.77 | 24.80 | 24.78 | 24.78 | 0.3006 |
| 20 | 1 | 49 | | 24.71 | 24.77 | 24.76 | | |
| 20 | 1 | 99 | | 24.75 | 24.63 | 24.49 | | |
| 20 | 50 | 0 | | 23.80 | 23.82 | 23.75 | | |
| 20 | 50 | 24 | | 23.76 | 23.76 | 23.71 | | |
| 20 | 50 | 50 | | 23.77 | 23.72 | 23.69 | | |
| 20 | 100 | 0 | | 23.75 | 23.86 | 23.72 | | |
| 20 | 1 | 0 | 16-QAM | 24.05 | 23.89 | 24.06 | 24.11 | 0.2576 |
| 20 | 1 | 49 | | 24.06 | 23.86 | 23.99 | | |
| 20 | 1 | 99 | | 24.13 | 23.85 | 23.84 | | |
| 20 | 50 | 0 | | 22.80 | 22.71 | 22.83 | | |
| 20 | 50 | 24 | | 22.81 | 22.74 | 22.78 | | |
| 20 | 50 | 50 | | 22.82 | 22.74 | 22.70 | | |
| 20 | 100 | 0 | | 22.81 | 22.75 | 22.70 | | |
| 20 | 1 | 0 | 64-QAM | 22.98 | 22.82 | 22.99 | 23.00 | 0.1995 |
| 20 | 1 | 49 | | 22.98 | 22.80 | 22.96 | | |
| 20 | 1 | 99 | | 23.02 | 22.83 | 22.86 | | |
| 20 | 50 | 0 | | 21.84 | 21.77 | 21.83 | | |
| 20 | 50 | 24 | | 21.88 | 21.78 | 21.78 | | |
| 20 | 50 | 50 | | 21.89 | 21.75 | 21.68 | | |
| 20 | 100 | 0 | | 21.86 | 21.76 | 21.72 | | |
| 20 | 1 | 0 | 256-QAM | 19.72 | 19.54 | 19.65 | 19.82 | 0.0959 |
| 20 | 1 | 49 | | 19.78 | 19.60 | 19.69 | | |
| 20 | 1 | 99 | | 19.84 | 19.68 | 19.69 | | |
| 20 | 50 | 0 | | 19.67 | 19.56 | 19.64 | | |
| 20 | 50 | 24 | | 19.73 | 19.61 | 19.68 | | |
| 20 | 50 | 50 | | 19.81 | 19.66 | 19.71 | | |
| 20 | 100 | 0 | | 19.73 | 19.63 | 19.73 | | |
| Limit | EIRP < 1W | | | Result | | | Pass | |



| LTE Band 4 Maximum Average Power [dBm] (GT - LC = -0.02 dB) | | | | | | | | |
|---|-----------|-----------|---------|--------|--------|---------|------------|----------|
| BW [MHz] | RB Size | RB Offset | Mod | Lowest | Middle | Highest | EIRP (dBm) | EIRP (W) |
| 15 | 1 | 0 | QPSK | 24.70 | 24.67 | 24.71 | 24.69 | 0.2944 |
| 15 | 1 | 37 | | 24.51 | 24.59 | 24.61 | | |
| 15 | 1 | 74 | | 24.63 | 24.50 | 24.43 | | |
| 15 | 36 | 0 | | 23.72 | 23.65 | 23.66 | | |
| 15 | 36 | 20 | | 23.76 | 23.67 | 23.53 | | |
| 15 | 36 | 39 | | 23.63 | 23.69 | 23.49 | | |
| 15 | 75 | 0 | | 23.56 | 23.75 | 23.72 | | |
| 15 | 1 | 0 | 16-QAM | 23.94 | 23.89 | 23.93 | 24.05 | 0.2541 |
| 15 | 1 | 37 | | 23.97 | 23.69 | 23.84 | | |
| 15 | 1 | 74 | | 24.07 | 23.73 | 23.79 | | |
| 15 | 36 | 0 | | 22.77 | 22.58 | 22.67 | | |
| 15 | 36 | 20 | | 22.74 | 22.73 | 22.75 | | |
| 15 | 36 | 39 | | 22.69 | 22.54 | 22.65 | | |
| 15 | 75 | 0 | | 22.75 | 22.68 | 22.53 | | |
| 15 | 1 | 0 | 64-QAM | 22.94 | 22.82 | 22.83 | 22.92 | 0.1959 |
| 15 | 1 | 37 | | 22.87 | 22.78 | 22.79 | | |
| 15 | 1 | 74 | | 22.94 | 22.71 | 22.81 | | |
| 15 | 36 | 0 | | 21.73 | 21.71 | 21.71 | | |
| 15 | 36 | 20 | | 21.76 | 21.68 | 21.75 | | |
| 15 | 36 | 39 | | 21.78 | 21.75 | 21.53 | | |
| 15 | 75 | 0 | | 21.77 | 21.69 | 21.53 | | |
| 15 | 1 | 0 | 256-QAM | 19.59 | 19.46 | 19.53 | 19.82 | 0.0959 |
| 15 | 1 | 37 | | 19.78 | 19.43 | 19.56 | | |
| 15 | 1 | 74 | | 19.84 | 19.65 | 19.69 | | |
| 15 | 36 | 0 | | 19.61 | 19.46 | 19.59 | | |
| 15 | 36 | 20 | | 19.62 | 19.57 | 19.64 | | |
| 15 | 36 | 39 | | 19.76 | 19.53 | 19.59 | | |
| 15 | 75 | 0 | | 19.72 | 19.51 | 19.57 | | |
| Limit | EIRP < 1W | | | Result | | | Pass | |



| LTE Band 4 Maximum Average Power [dBm] (GT - LC = -0.02 dB) | | | | | | | | |
|---|-----------|-----------|---------|--------|--------|---------|------------|----------|
| BW [MHz] | RB Size | RB Offset | Mod | Lowest | Middle | Highest | EIRP (dBm) | EIRP (W) |
| 10 | 1 | 0 | QPSK | 24.61 | 24.67 | 24.73 | 24.72 | 0.2965 |
| 10 | 1 | 25 | | 24.54 | 24.60 | 24.74 | | |
| 10 | 1 | 49 | | 24.73 | 24.61 | 24.48 | | |
| 10 | 25 | 0 | | 23.71 | 23.62 | 23.74 | | |
| 10 | 25 | 12 | | 23.76 | 23.76 | 23.59 | | |
| 10 | 25 | 25 | | 23.63 | 23.69 | 23.59 | | |
| 10 | 50 | 0 | | 23.66 | 23.73 | 23.53 | | |
| 10 | 1 | 0 | 16-QAM | 23.87 | 23.70 | 23.97 | 24.11 | 0.2576 |
| 10 | 1 | 25 | | 23.98 | 23.83 | 23.90 | | |
| 10 | 1 | 49 | | 24.13 | 23.78 | 23.64 | | |
| 10 | 25 | 0 | | 22.63 | 22.53 | 22.64 | | |
| 10 | 25 | 12 | | 22.73 | 22.69 | 22.76 | | |
| 10 | 25 | 25 | | 22.80 | 22.54 | 22.61 | | |
| 10 | 50 | 0 | | 22.61 | 22.73 | 22.53 | | |
| 10 | 1 | 0 | 64-QAM | 22.85 | 22.79 | 22.95 | 22.98 | 0.1986 |
| 10 | 1 | 25 | | 22.87 | 22.77 | 22.78 | | |
| 10 | 1 | 49 | | 23.00 | 22.72 | 22.72 | | |
| 10 | 25 | 0 | | 21.81 | 21.68 | 21.71 | | |
| 10 | 25 | 12 | | 21.76 | 21.64 | 21.76 | | |
| 10 | 25 | 25 | | 21.82 | 21.67 | 21.49 | | |
| 10 | 50 | 0 | | 21.70 | 21.57 | 21.57 | | |
| 10 | 1 | 0 | 256-QAM | 19.52 | 19.35 | 19.48 | 19.77 | 0.0948 |
| 10 | 1 | 25 | | 19.61 | 19.48 | 19.56 | | |
| 10 | 1 | 49 | | 19.79 | 19.54 | 19.55 | | |
| 10 | 25 | 0 | | 19.63 | 19.49 | 19.46 | | |
| 10 | 25 | 12 | | 19.68 | 19.42 | 19.53 | | |
| 10 | 25 | 25 | | 19.78 | 19.49 | 19.70 | | |
| 10 | 50 | 0 | | 19.69 | 19.54 | 19.69 | | |
| Limit | EIRP < 1W | | | Result | | | Pass | |



| LTE Band 4 Maximum Average Power [dBm] (GT - LC = -0.02 dB) | | | | | | | | |
|---|-----------|-----------|---------|--------|--------|---------|------------|----------|
| BW [MHz] | RB Size | RB Offset | Mod | Lowest | Middle | Highest | EIRP (dBm) | EIRP (W) |
| 5 | 1 | 0 | QPSK | 24.74 | 24.78 | 24.78 | 24.76 | 0.2992 |
| 5 | 1 | 12 | | 24.51 | 24.59 | 24.58 | | |
| 5 | 1 | 24 | | 24.73 | 24.59 | 24.32 | | |
| 5 | 12 | 0 | | 23.66 | 23.78 | 23.64 | | |
| 5 | 12 | 7 | | 23.64 | 23.64 | 23.61 | | |
| 5 | 12 | 13 | | 23.76 | 23.62 | 23.57 | | |
| 5 | 25 | 0 | | 23.57 | 23.69 | 23.58 | | |
| 5 | 1 | 0 | 16-QAM | 24.05 | 23.75 | 23.94 | 24.06 | 0.2547 |
| 5 | 1 | 12 | | 24.05 | 23.86 | 23.82 | | |
| 5 | 1 | 24 | | 24.08 | 23.75 | 23.81 | | |
| 5 | 12 | 0 | | 22.76 | 22.64 | 22.74 | | |
| 5 | 12 | 7 | | 22.77 | 22.73 | 22.75 | | |
| 5 | 12 | 13 | | 22.72 | 22.59 | 22.58 | | |
| 5 | 25 | 0 | | 22.73 | 22.56 | 22.59 | | |
| 5 | 1 | 0 | 64-QAM | 22.83 | 22.72 | 22.99 | 22.99 | 0.1991 |
| 5 | 1 | 12 | | 22.83 | 22.68 | 22.96 | | |
| 5 | 1 | 24 | | 23.01 | 22.63 | 22.76 | | |
| 5 | 12 | 0 | | 21.76 | 21.73 | 21.65 | | |
| 5 | 12 | 7 | | 21.69 | 21.61 | 21.60 | | |
| 5 | 12 | 13 | | 21.84 | 21.70 | 21.57 | | |
| 5 | 25 | 0 | | 21.77 | 21.56 | 21.70 | | |
| 5 | 1 | 0 | 256-QAM | 19.68 | 19.36 | 19.46 | 19.78 | 0.0951 |
| 5 | 1 | 12 | | 19.64 | 19.57 | 19.60 | | |
| 5 | 1 | 24 | | 19.69 | 19.49 | 19.62 | | |
| 5 | 12 | 0 | | 19.54 | 19.40 | 19.53 | | |
| 5 | 12 | 7 | | 19.61 | 19.52 | 19.52 | | |
| 5 | 12 | 13 | | 19.80 | 19.55 | 19.51 | | |
| 5 | 25 | 0 | | 19.57 | 19.60 | 19.73 | | |
| Limit | EIRP < 1W | | | Result | | | Pass | |



| LTE Band 4 Maximum Average Power [dBm] (GT - LC = -0.02 dB) | | | | | | | | |
|---|-----------|-----------|---------|--------|--------|---------|------------|----------|
| BW [MHz] | RB Size | RB Offset | Mod | Lowest | Middle | Highest | EIRP (dBm) | EIRP (W) |
| 3 | 1 | 0 | QPSK | 24.67 | 24.63 | 24.70 | 24.68 | 0.2938 |
| 3 | 1 | 8 | | 24.65 | 24.62 | 24.62 | | |
| 3 | 1 | 14 | | 24.63 | 24.49 | 24.41 | | |
| 3 | 8 | 0 | | 23.76 | 23.73 | 23.75 | | |
| 3 | 8 | 4 | | 23.69 | 23.57 | 23.54 | | |
| 3 | 8 | 7 | | 23.57 | 23.56 | 23.55 | | |
| 3 | 15 | 0 | | 23.67 | 23.68 | 23.72 | | |
| 3 | 1 | 0 | 16-QAM | 23.96 | 23.89 | 23.95 | 24.04 | 0.2535 |
| 3 | 1 | 8 | | 24.06 | 23.76 | 23.79 | | |
| 3 | 1 | 14 | | 24.01 | 23.85 | 23.66 | | |
| 3 | 8 | 0 | | 22.61 | 22.67 | 22.74 | | |
| 3 | 8 | 4 | | 22.81 | 22.58 | 22.66 | | |
| 3 | 8 | 7 | | 22.81 | 22.73 | 22.50 | | |
| 3 | 15 | 0 | | 22.73 | 22.56 | 22.64 | | |
| 3 | 1 | 0 | 64-QAM | 22.91 | 22.74 | 22.97 | 22.95 | 0.1972 |
| 3 | 1 | 8 | | 22.92 | 22.65 | 22.76 | | |
| 3 | 1 | 14 | | 22.97 | 22.63 | 22.66 | | |
| 3 | 8 | 0 | | 21.66 | 21.61 | 21.76 | | |
| 3 | 8 | 4 | | 21.81 | 21.67 | 21.62 | | |
| 3 | 8 | 7 | | 21.75 | 21.57 | 21.65 | | |
| 3 | 15 | 0 | | 21.83 | 21.65 | 21.52 | | |
| 3 | 1 | 0 | 256-QAM | 19.63 | 19.36 | 19.54 | 19.79 | 0.0953 |
| 3 | 1 | 8 | | 19.70 | 19.47 | 19.61 | | |
| 3 | 1 | 14 | | 19.80 | 19.62 | 19.51 | | |
| 3 | 8 | 0 | | 19.58 | 19.46 | 19.52 | | |
| 3 | 8 | 4 | | 19.53 | 19.41 | 19.68 | | |
| 3 | 8 | 7 | | 19.81 | 19.58 | 19.58 | | |
| 3 | 15 | 0 | | 19.60 | 19.56 | 19.72 | | |
| Limit | EIRP < 1W | | | Result | | | Pass | |



| LTE Band 4 Maximum Average Power [dBm] (GT - LC = -0.02 dB) | | | | | | | | |
|---|-----------|-----------|---------|--------|--------|---------|------------|----------|
| BW [MHz] | RB Size | RB Offset | Mod | Lowest | Middle | Highest | EIRP (dBm) | EIRP (W) |
| 1.4 | 1 | 0 | QPSK | 24.69 | 24.71 | 24.72 | 24.75 | 0.2985 |
| 1.4 | 1 | 3 | | 24.68 | 24.77 | 24.58 | | |
| 1.4 | 1 | 5 | | 24.63 | 24.51 | 24.31 | | |
| 1.4 | 3 | 0 | | 24.74 | 24.60 | 24.64 | | |
| 1.4 | 3 | 1 | | 24.52 | 24.75 | 24.61 | | |
| 1.4 | 3 | 3 | | 24.58 | 24.60 | 24.34 | | |
| 1.4 | 6 | 0 | | 23.62 | 23.68 | 23.58 | | |
| 1.4 | 1 | 0 | 16-QAM | 23.60 | 23.67 | 23.52 | 24.05 | 0.2541 |
| 1.4 | 1 | 3 | | 23.62 | 23.63 | 23.53 | | |
| 1.4 | 1 | 5 | | 23.55 | 23.76 | 23.69 | | |
| 1.4 | 3 | 0 | | 23.91 | 23.70 | 23.87 | | |
| 1.4 | 3 | 1 | | 23.99 | 23.81 | 23.83 | | |
| 1.4 | 3 | 3 | | 24.07 | 23.78 | 23.68 | | |
| 1.4 | 6 | 0 | | 22.68 | 22.68 | 22.79 | | |
| 1.4 | 1 | 0 | 64-QAM | 22.68 | 22.59 | 22.72 | 22.89 | 0.1945 |
| 1.4 | 1 | 3 | | 22.70 | 22.64 | 22.51 | | |
| 1.4 | 1 | 5 | | 22.69 | 22.55 | 22.61 | | |
| 1.4 | 3 | 0 | | 22.80 | 22.65 | 22.91 | | |
| 1.4 | 3 | 1 | | 22.90 | 22.64 | 22.87 | | |
| 1.4 | 3 | 3 | | 22.88 | 22.76 | 22.71 | | |
| 1.4 | 6 | 0 | | 21.70 | 21.74 | 21.79 | | |
| 1.4 | 1 | 0 | 256-QAM | 19.62 | 19.44 | 19.55 | 19.77 | 0.0948 |
| 1.4 | 1 | 3 | | 19.78 | 19.40 | 19.65 | | |
| 1.4 | 1 | 5 | | 19.79 | 19.48 | 19.56 | | |
| 1.4 | 3 | 0 | | 19.49 | 19.37 | 19.44 | | |
| 1.4 | 3 | 1 | | 19.58 | 19.61 | 19.63 | | |
| 1.4 | 3 | 3 | | 19.76 | 19.64 | 19.68 | | |
| 1.4 | 6 | 0 | | 19.63 | 19.53 | 19.71 | | |
| Limit | EIRP < 1W | | | Result | | | Pass | |



| LTE Band 5 Maximum Average Power [dBm] (GT - LC = -1.9 dB) | | | | | | | | |
|--|----------|-----------|---------|--------|--------|---------|-----------|---------|
| BW [MHz] | RB Size | RB Offset | Mod | Lowest | Middle | Highest | ERP (dBm) | ERP (W) |
| 10 | 1 | 0 | QPSK | 24.32 | 24.31 | 24.34 | 20.29 | 0.1069 |
| 10 | 1 | 25 | | 24.16 | 24.12 | 24.11 | | |
| 10 | 1 | 49 | | 24.23 | 24.24 | 24.16 | | |
| 10 | 25 | 0 | | 23.31 | 23.24 | 23.30 | | |
| 10 | 25 | 12 | | 23.26 | 23.22 | 23.28 | | |
| 10 | 25 | 25 | | 23.27 | 23.21 | 23.24 | | |
| 10 | 50 | 0 | | 23.27 | 23.24 | 23.26 | | |
| 10 | 1 | 0 | 16-QAM | 23.48 | 23.67 | 23.62 | 19.70 | 0.0933 |
| 10 | 1 | 25 | | 23.56 | 23.68 | 23.52 | | |
| 10 | 1 | 49 | | 23.75 | 23.52 | 23.52 | | |
| 10 | 25 | 0 | | 22.30 | 22.34 | 22.31 | | |
| 10 | 25 | 12 | | 22.30 | 22.31 | 22.29 | | |
| 10 | 25 | 25 | | 22.30 | 22.31 | 22.26 | | |
| 10 | 50 | 0 | | 22.27 | 22.27 | 22.25 | | |
| 10 | 1 | 0 | 64-QAM | 22.34 | 22.36 | 22.42 | 18.41 | 0.0693 |
| 10 | 1 | 25 | | 22.35 | 22.32 | 22.28 | | |
| 10 | 1 | 49 | | 22.46 | 22.38 | 22.36 | | |
| 10 | 25 | 0 | | 21.29 | 21.32 | 21.26 | | |
| 10 | 25 | 12 | | 21.31 | 21.29 | 21.24 | | |
| 10 | 25 | 25 | | 21.30 | 21.27 | 21.25 | | |
| 10 | 50 | 0 | | 21.29 | 21.31 | 21.24 | | |
| 10 | 1 | 0 | 256-QAM | 19.42 | 19.41 | 19.38 | 15.37 | 0.0344 |
| 10 | 1 | 25 | | 19.17 | 19.24 | 19.18 | | |
| 10 | 1 | 49 | | 19.23 | 19.32 | 19.27 | | |
| 10 | 25 | 0 | | 19.22 | 19.24 | 19.14 | | |
| 10 | 25 | 12 | | 19.18 | 19.23 | 19.10 | | |
| 10 | 25 | 25 | | 19.21 | 19.23 | 19.13 | | |
| 10 | 50 | 0 | | 19.14 | 19.21 | 19.11 | | |
| Limit | ERP < 7W | | | Result | | | Pass | |



| LTE Band 5 Maximum Average Power [dBm] (GT - LC = -1.9 dB) | | | | | | | | |
|--|----------|-----------|---------|--------|--------|---------|-----------|---------|
| BW [MHz] | RB Size | RB Offset | Mod | Lowest | Middle | Highest | ERP (dBm) | ERP (W) |
| 5 | 1 | 0 | QPSK | 24.21 | 24.27 | 24.16 | 20.22 | 0.1052 |
| 5 | 1 | 12 | | 23.99 | 24.03 | 24.06 | | |
| 5 | 1 | 24 | | 24.09 | 24.13 | 24.13 | | |
| 5 | 12 | 0 | | 23.11 | 23.20 | 23.20 | | |
| 5 | 12 | 7 | | 23.19 | 23.16 | 23.25 | | |
| 5 | 12 | 13 | | 23.26 | 23.21 | 23.22 | | |
| 5 | 25 | 0 | | 23.26 | 23.07 | 23.16 | | |
| 5 | 1 | 0 | 16-QAM | 23.37 | 23.56 | 23.57 | 19.52 | 0.0895 |
| 5 | 1 | 12 | | 23.43 | 23.50 | 23.32 | | |
| 5 | 1 | 24 | | 23.55 | 23.47 | 23.45 | | |
| 5 | 12 | 0 | | 22.23 | 22.31 | 22.21 | | |
| 5 | 12 | 7 | | 22.28 | 22.16 | 22.26 | | |
| 5 | 12 | 13 | | 22.27 | 22.30 | 22.13 | | |
| 5 | 25 | 0 | | 22.14 | 22.14 | 22.08 | | |
| 5 | 1 | 0 | 64-QAM | 22.19 | 22.34 | 22.39 | 18.38 | 0.0689 |
| 5 | 1 | 12 | | 22.17 | 22.28 | 22.18 | | |
| 5 | 1 | 24 | | 22.43 | 22.22 | 22.24 | | |
| 5 | 12 | 0 | | 21.24 | 21.19 | 21.13 | | |
| 5 | 12 | 7 | | 21.29 | 21.19 | 21.15 | | |
| 5 | 12 | 13 | | 21.17 | 21.12 | 21.13 | | |
| 5 | 25 | 0 | | 21.11 | 21.23 | 21.21 | | |
| 5 | 1 | 0 | 256-QAM | 19.33 | 19.27 | 19.20 | 15.28 | 0.0337 |
| 5 | 1 | 12 | | 19.14 | 19.13 | 19.16 | | |
| 5 | 1 | 24 | | 19.06 | 19.31 | 19.17 | | |
| 5 | 12 | 0 | | 19.12 | 19.04 | 19.07 | | |
| 5 | 12 | 7 | | 19.15 | 19.23 | 18.96 | | |
| 5 | 12 | 13 | | 19.16 | 19.12 | 18.98 | | |
| 5 | 25 | 0 | | 18.97 | 19.19 | 19.03 | | |
| Limit | ERP < 7W | | | Result | | | Pass | |



| LTE Band 5 Maximum Average Power [dBm] (GT - LC = -1.9 dB) | | | | | | | | |
|--|----------|-----------|---------|--------|--------|---------|-----------|---------|
| BW [MHz] | RB Size | RB Offset | Mod | Lowest | Middle | Highest | ERP (dBm) | ERP (W) |
| 3 | 1 | 0 | QPSK | 24.26 | 24.30 | 24.30 | 20.25 | 0.1059 |
| 3 | 1 | 8 | | 24.11 | 24.10 | 24.09 | | |
| 3 | 1 | 14 | | 24.18 | 24.14 | 24.11 | | |
| 3 | 8 | 0 | | 23.22 | 23.11 | 23.23 | | |
| 3 | 8 | 4 | | 23.10 | 23.06 | 23.27 | | |
| 3 | 8 | 7 | | 23.13 | 23.02 | 23.15 | | |
| 3 | 15 | 0 | | 23.23 | 23.17 | 23.11 | | |
| 3 | 1 | 0 | 16-QAM | 23.34 | 23.52 | 23.53 | 19.58 | 0.0908 |
| 3 | 1 | 8 | | 23.37 | 23.63 | 23.45 | | |
| 3 | 1 | 14 | | 23.62 | 23.48 | 23.49 | | |
| 3 | 8 | 0 | | 22.23 | 22.19 | 22.26 | | |
| 3 | 8 | 4 | | 22.27 | 22.16 | 22.15 | | |
| 3 | 8 | 7 | | 22.20 | 22.31 | 22.08 | | |
| 3 | 15 | 0 | | 22.14 | 22.12 | 22.16 | | |
| 3 | 1 | 0 | 64-QAM | 22.33 | 22.33 | 22.37 | 18.32 | 0.0679 |
| 3 | 1 | 8 | | 22.31 | 22.30 | 22.20 | | |
| 3 | 1 | 14 | | 22.33 | 22.23 | 22.19 | | |
| 3 | 8 | 0 | | 21.23 | 21.31 | 21.08 | | |
| 3 | 8 | 4 | | 21.21 | 21.27 | 21.10 | | |
| 3 | 8 | 7 | | 21.22 | 21.16 | 21.25 | | |
| 3 | 15 | 0 | | 21.28 | 21.31 | 21.24 | | |
| 3 | 1 | 0 | 256-QAM | 19.31 | 19.27 | 19.18 | 15.26 | 0.0336 |
| 3 | 1 | 8 | | 19.13 | 19.06 | 19.16 | | |
| 3 | 1 | 14 | | 19.19 | 19.16 | 19.24 | | |
| 3 | 8 | 0 | | 19.14 | 19.19 | 19.08 | | |
| 3 | 8 | 4 | | 19.03 | 19.15 | 19.07 | | |
| 3 | 8 | 7 | | 19.11 | 19.10 | 18.95 | | |
| 3 | 15 | 0 | | 19.11 | 19.10 | 18.94 | | |
| Limit | ERP < 7W | | | Result | | | Pass | |



| LTE Band 5 Maximum Average Power [dBm] (GT - LC = -1.9 dB) | | | | | | | | |
|--|----------|-----------|---------|--------|--------|---------|-----------|---------|
| BW [MHz] | RB Size | RB Offset | Mod | Lowest | Middle | Highest | ERP (dBm) | ERP (W) |
| 1.4 | 1 | 0 | QPSK | 24.29 | 24.12 | 24.14 | 20.24 | 0.1057 |
| 1.4 | 1 | 3 | | 24.02 | 24.09 | 24.05 | | |
| 1.4 | 1 | 5 | | 24.21 | 24.18 | 24.12 | | |
| 1.4 | 3 | 0 | | 24.25 | 24.24 | 24.16 | | |
| 1.4 | 3 | 1 | | 23.97 | 23.92 | 24.02 | | |
| 1.4 | 3 | 3 | | 24.15 | 24.10 | 24.13 | | |
| 1.4 | 6 | 0 | | 23.12 | 23.07 | 23.13 | | |
| 1.4 | 1 | 0 | 16-QAM | 23.10 | 23.14 | 23.27 | 19.61 | 0.0914 |
| 1.4 | 1 | 3 | | 23.25 | 23.03 | 23.22 | | |
| 1.4 | 1 | 5 | | 23.09 | 23.18 | 23.22 | | |
| 1.4 | 3 | 0 | | 23.28 | 23.58 | 23.52 | | |
| 1.4 | 3 | 1 | | 23.50 | 23.49 | 23.37 | | |
| 1.4 | 3 | 3 | | 23.66 | 23.34 | 23.33 | | |
| 1.4 | 6 | 0 | | 22.12 | 22.19 | 22.12 | | |
| 1.4 | 1 | 0 | 64-QAM | 22.24 | 22.18 | 22.13 | 18.34 | 0.0682 |
| 1.4 | 1 | 3 | | 22.29 | 22.30 | 22.09 | | |
| 1.4 | 1 | 5 | | 22.09 | 22.20 | 22.20 | | |
| 1.4 | 3 | 0 | | 22.23 | 22.32 | 22.39 | | |
| 1.4 | 3 | 1 | | 22.30 | 22.17 | 22.23 | | |
| 1.4 | 3 | 3 | | 22.35 | 22.19 | 22.18 | | |
| 1.4 | 6 | 0 | | 21.09 | 21.24 | 21.15 | | |
| 1.4 | 1 | 0 | 256-QAM | 19.35 | 19.40 | 19.38 | 15.35 | 0.0343 |
| 1.4 | 1 | 3 | | 19.07 | 19.20 | 19.04 | | |
| 1.4 | 1 | 5 | | 19.13 | 19.16 | 19.18 | | |
| 1.4 | 3 | 0 | | 19.13 | 19.20 | 18.99 | | |
| 1.4 | 3 | 1 | | 19.00 | 19.16 | 18.91 | | |
| 1.4 | 3 | 3 | | 19.01 | 19.12 | 19.00 | | |
| 1.4 | 6 | 0 | | 19.08 | 19.06 | 18.94 | | |
| Limit | ERP < 7W | | | Result | | | Pass | |



| LTE Band 7 Maximum Average Power [dBm] (GT - LC = 0.32 dB) | | | | | | | | |
|--|-----------|-----------|---------|--------|--------|---------|------------|----------|
| BW [MHz] | RB Size | RB Offset | Mod | Lowest | Middle | Highest | EIRP (dBm) | EIRP (W) |
| 20 | 1 | 0 | QPSK | 24.74 | 24.60 | 24.82 | 25.14 | 0.3266 |
| 20 | 1 | 49 | | 24.73 | 24.57 | 24.73 | | |
| 20 | 1 | 99 | | 24.72 | 24.49 | 24.78 | | |
| 20 | 50 | 0 | | 23.77 | 23.72 | 23.79 | | |
| 20 | 50 | 24 | | 23.72 | 23.70 | 23.78 | | |
| 20 | 50 | 50 | | 23.71 | 23.71 | 23.75 | | |
| 20 | 100 | 0 | | 23.73 | 23.63 | 23.76 | | |
| 20 | 1 | 0 | 16-QAM | 24.00 | 24.01 | 24.16 | 24.53 | 0.2838 |
| 20 | 1 | 49 | | 24.07 | 23.95 | 24.21 | | |
| 20 | 1 | 99 | | 24.05 | 23.91 | 24.19 | | |
| 20 | 50 | 0 | | 22.74 | 22.69 | 22.84 | | |
| 20 | 50 | 24 | | 22.74 | 22.66 | 22.86 | | |
| 20 | 50 | 50 | | 22.78 | 22.67 | 22.87 | | |
| 20 | 100 | 0 | | 22.71 | 22.63 | 22.79 | | |
| 20 | 1 | 0 | 64-QAM | 23.02 | 22.80 | 23.14 | 23.46 | 0.2218 |
| 20 | 1 | 49 | | 23.04 | 22.82 | 22.92 | | |
| 20 | 1 | 99 | | 23.10 | 22.82 | 23.00 | | |
| 20 | 50 | 0 | | 21.79 | 21.69 | 21.84 | | |
| 20 | 50 | 24 | | 21.81 | 21.72 | 21.84 | | |
| 20 | 50 | 50 | | 21.84 | 21.70 | 21.88 | | |
| 20 | 100 | 0 | | 21.76 | 21.64 | 21.79 | | |
| 20 | 1 | 0 | 256-QAM | 19.93 | 19.77 | 20.00 | 20.32 | 0.1076 |
| 20 | 1 | 49 | | 19.73 | 19.59 | 19.78 | | |
| 20 | 1 | 99 | | 19.52 | 19.46 | 19.69 | | |
| 20 | 50 | 0 | | 19.64 | 19.57 | 19.77 | | |
| 20 | 50 | 24 | | 19.75 | 19.60 | 19.75 | | |
| 20 | 50 | 50 | | 19.66 | 19.51 | 19.70 | | |
| 20 | 100 | 0 | | 19.67 | 19.53 | 19.75 | | |
| Limit | EIRP < 2W | | | Result | | | Pass | |



| LTE Band 7 Maximum Average Power [dBm] (GT - LC = 0.32 dB) | | | | | | | | |
|--|-----------|-----------|---------|--------|--------|---------|------------|----------|
| BW [MHz] | RB Size | RB Offset | Mod | Lowest | Middle | Highest | EIRP (dBm) | EIRP (W) |
| 15 | 1 | 0 | QPSK | 24.58 | 24.40 | 24.77 | 25.09 | 0.3228 |
| 15 | 1 | 37 | | 24.72 | 24.40 | 24.53 | | |
| 15 | 1 | 74 | | 24.62 | 24.46 | 24.75 | | |
| 15 | 36 | 0 | | 23.63 | 23.62 | 23.64 | | |
| 15 | 36 | 20 | | 23.52 | 23.52 | 23.66 | | |
| 15 | 36 | 39 | | 23.66 | 23.62 | 23.63 | | |
| 15 | 75 | 0 | | 23.64 | 23.50 | 23.76 | | |
| 15 | 1 | 0 | 16-QAM | 23.98 | 23.87 | 23.97 | 24.43 | 0.2773 |
| 15 | 1 | 37 | | 23.98 | 23.89 | 24.01 | | |
| 15 | 1 | 74 | | 23.95 | 23.84 | 24.11 | | |
| 15 | 36 | 0 | | 22.57 | 22.61 | 22.72 | | |
| 15 | 36 | 20 | | 22.63 | 22.52 | 22.77 | | |
| 15 | 36 | 39 | | 22.59 | 22.52 | 22.75 | | |
| 15 | 75 | 0 | | 22.55 | 22.62 | 22.67 | | |
| 15 | 1 | 0 | 64-QAM | 22.94 | 22.71 | 23.00 | 23.41 | 0.2193 |
| 15 | 1 | 37 | | 22.89 | 22.71 | 22.88 | | |
| 15 | 1 | 74 | | 23.09 | 22.64 | 22.82 | | |
| 15 | 36 | 0 | | 21.75 | 21.57 | 21.67 | | |
| 15 | 36 | 20 | | 21.76 | 21.63 | 21.67 | | |
| 15 | 36 | 39 | | 21.79 | 21.64 | 21.83 | | |
| 15 | 75 | 0 | | 21.72 | 21.44 | 21.72 | | |
| 15 | 1 | 0 | 256-QAM | 19.88 | 19.77 | 19.85 | 20.20 | 0.1047 |
| 15 | 1 | 37 | | 19.66 | 19.39 | 19.76 | | |
| 15 | 1 | 74 | | 19.34 | 19.33 | 19.53 | | |
| 15 | 36 | 0 | | 19.62 | 19.52 | 19.67 | | |
| 15 | 36 | 20 | | 19.67 | 19.56 | 19.73 | | |
| 15 | 36 | 39 | | 19.48 | 19.31 | 19.61 | | |
| 15 | 75 | 0 | | 19.47 | 19.40 | 19.57 | | |
| Limit | EIRP < 2W | | | Result | | | Pass | |



| LTE Band 7 Maximum Average Power [dBm] (GT - LC = 0.32 dB) | | | | | | | | |
|--|-----------|-----------|---------|--------|--------|---------|------------|----------|
| BW [MHz] | RB Size | RB Offset | Mod | Lowest | Middle | Highest | EIRP (dBm) | EIRP (W) |
| 10 | 1 | 0 | QPSK | 24.65 | 24.43 | 24.81 | 25.13 | 0.3258 |
| 10 | 1 | 25 | | 24.53 | 24.41 | 24.54 | | |
| 10 | 1 | 49 | | 24.53 | 24.46 | 24.61 | | |
| 10 | 25 | 0 | | 23.66 | 23.54 | 23.73 | | |
| 10 | 25 | 12 | | 23.54 | 23.70 | 23.72 | | |
| 10 | 25 | 25 | | 23.70 | 23.61 | 23.75 | | |
| 10 | 50 | 0 | | 23.66 | 23.53 | 23.63 | | |
| 10 | 1 | 0 | 16-QAM | 23.97 | 23.85 | 24.04 | 24.45 | 0.2786 |
| 10 | 1 | 25 | | 23.87 | 23.81 | 24.02 | | |
| 10 | 1 | 49 | | 23.93 | 23.73 | 24.13 | | |
| 10 | 25 | 0 | | 22.55 | 22.66 | 22.73 | | |
| 10 | 25 | 12 | | 22.62 | 22.54 | 22.86 | | |
| 10 | 25 | 25 | | 22.62 | 22.66 | 22.68 | | |
| 10 | 50 | 0 | | 22.70 | 22.62 | 22.75 | | |
| 10 | 1 | 0 | 64-QAM | 22.94 | 22.80 | 23.10 | 23.42 | 0.2198 |
| 10 | 1 | 25 | | 22.84 | 22.63 | 22.85 | | |
| 10 | 1 | 49 | | 22.92 | 22.62 | 22.86 | | |
| 10 | 25 | 0 | | 21.64 | 21.57 | 21.81 | | |
| 10 | 25 | 12 | | 21.64 | 21.72 | 21.76 | | |
| 10 | 25 | 25 | | 21.83 | 21.62 | 21.82 | | |
| 10 | 50 | 0 | | 21.67 | 21.60 | 21.63 | | |
| 10 | 1 | 0 | 256-QAM | 19.86 | 19.72 | 20.00 | 20.32 | 0.1076 |
| 10 | 1 | 25 | | 19.65 | 19.48 | 19.76 | | |
| 10 | 1 | 49 | | 19.40 | 19.26 | 19.65 | | |
| 10 | 25 | 0 | | 19.56 | 19.52 | 19.77 | | |
| 10 | 25 | 12 | | 19.57 | 19.48 | 19.64 | | |
| 10 | 25 | 25 | | 19.63 | 19.36 | 19.55 | | |
| 10 | 50 | 0 | | 19.56 | 19.40 | 19.75 | | |
| Limit | EIRP < 2W | | | Result | | | Pass | |



| LTE Band 7 Maximum Average Power [dBm] (GT - LC = 0.32 dB) | | | | | | | | |
|--|-----------|-----------|---------|--------|--------|---------|------------|----------|
| BW [MHz] | RB Size | RB Offset | Mod | Lowest | Middle | Highest | EIRP (dBm) | EIRP (W) |
| 5 | 1 | 0 | QPSK | 24.68 | 24.59 | 24.73 | 25.06 | 0.3206 |
| 5 | 1 | 12 | | 24.73 | 24.39 | 24.72 | | |
| 5 | 1 | 24 | | 24.68 | 24.41 | 24.74 | | |
| 5 | 12 | 0 | | 23.63 | 23.57 | 23.65 | | |
| 5 | 12 | 7 | | 23.66 | 23.52 | 23.58 | | |
| 5 | 12 | 13 | | 23.67 | 23.66 | 23.68 | | |
| 5 | 25 | 0 | | 23.55 | 23.62 | 23.61 | | |
| 5 | 1 | 0 | 16-QAM | 23.88 | 23.89 | 24.06 | 24.48 | 0.2805 |
| 5 | 1 | 12 | | 23.87 | 23.89 | 24.16 | | |
| 5 | 1 | 24 | | 23.99 | 23.73 | 24.13 | | |
| 5 | 12 | 0 | | 22.57 | 22.68 | 22.83 | | |
| 5 | 12 | 7 | | 22.62 | 22.63 | 22.73 | | |
| 5 | 12 | 13 | | 22.71 | 22.47 | 22.73 | | |
| 5 | 25 | 0 | | 22.56 | 22.62 | 22.72 | | |
| 5 | 1 | 0 | 64-QAM | 22.87 | 22.73 | 23.13 | 23.45 | 0.2213 |
| 5 | 1 | 12 | | 23.03 | 22.63 | 22.74 | | |
| 5 | 1 | 24 | | 22.92 | 22.78 | 22.96 | | |
| 5 | 12 | 0 | | 21.77 | 21.54 | 21.67 | | |
| 5 | 12 | 7 | | 21.78 | 21.67 | 21.66 | | |
| 5 | 12 | 13 | | 21.69 | 21.63 | 21.72 | | |
| 5 | 25 | 0 | | 21.72 | 21.45 | 21.67 | | |
| 5 | 1 | 0 | 256-QAM | 19.90 | 19.74 | 19.96 | 20.28 | 0.1067 |
| 5 | 1 | 12 | | 19.67 | 19.55 | 19.67 | | |
| 5 | 1 | 24 | | 19.48 | 19.46 | 19.59 | | |
| 5 | 12 | 0 | | 19.53 | 19.44 | 19.69 | | |
| 5 | 12 | 7 | | 19.65 | 19.57 | 19.63 | | |
| 5 | 12 | 13 | | 19.47 | 19.35 | 19.63 | | |
| 5 | 25 | 0 | | 19.65 | 19.43 | 19.74 | | |
| Limit | EIRP < 2W | | | Result | | | Pass | |



| LTE Band 12 Maximum Average Power [dBm] (GT - LC = -1.02 dB) | | | | | | | | |
|--|----------|-----------|---------|--------|--------|---------|-----------|---------|
| BW [MHz] | RB Size | RB Offset | Mod | Lowest | Middle | Highest | ERP (dBm) | ERP (W) |
| 10 | 1 | 0 | QPSK | 24.60 | 24.56 | 24.56 | 21.43 | 0.1390 |
| 10 | 1 | 25 | | 24.43 | 24.37 | 24.42 | | |
| 10 | 1 | 49 | | 24.51 | 24.52 | 24.50 | | |
| 10 | 25 | 0 | | 23.59 | 23.61 | 23.56 | | |
| 10 | 25 | 12 | | 23.60 | 23.58 | 23.54 | | |
| 10 | 25 | 25 | | 23.58 | 23.57 | 23.56 | | |
| 10 | 50 | 0 | | 23.58 | 23.58 | 23.58 | | |
| 10 | 1 | 0 | 16-QAM | 23.91 | 23.77 | 23.74 | 20.74 | 0.1186 |
| 10 | 1 | 25 | | 23.84 | 23.82 | 23.90 | | |
| 10 | 1 | 49 | | 23.91 | 23.88 | 23.72 | | |
| 10 | 25 | 0 | | 22.59 | 22.59 | 22.57 | | |
| 10 | 25 | 12 | | 22.56 | 22.58 | 22.58 | | |
| 10 | 25 | 25 | | 22.59 | 22.59 | 22.58 | | |
| 10 | 50 | 0 | | 22.55 | 22.54 | 22.56 | | |
| 10 | 1 | 0 | 64-QAM | 22.83 | 22.68 | 22.64 | 19.68 | 0.0929 |
| 10 | 1 | 25 | | 22.66 | 22.69 | 22.69 | | |
| 10 | 1 | 49 | | 22.80 | 22.85 | 22.65 | | |
| 10 | 25 | 0 | | 21.56 | 21.50 | 21.55 | | |
| 10 | 25 | 12 | | 21.57 | 21.59 | 21.59 | | |
| 10 | 25 | 25 | | 21.58 | 21.58 | 21.57 | | |
| 10 | 50 | 0 | | 21.56 | 21.57 | 21.56 | | |
| 10 | 1 | 0 | 256-QAM | 19.87 | 19.76 | 19.80 | 16.70 | 0.0468 |
| 10 | 1 | 25 | | 19.45 | 19.37 | 19.41 | | |
| 10 | 1 | 49 | | 19.62 | 19.54 | 19.48 | | |
| 10 | 25 | 0 | | 19.78 | 19.74 | 19.75 | | |
| 10 | 25 | 12 | | 19.51 | 19.48 | 19.52 | | |
| 10 | 25 | 25 | | 19.51 | 19.44 | 19.48 | | |
| 10 | 50 | 0 | | 19.65 | 19.62 | 19.58 | | |
| Limit | ERP < 3W | | | Result | | | Pass | |



| LTE Band 12 Maximum Average Power [dBm] (GT - LC = -1.02 dB) | | | | | | | | |
|--|----------|-----------|---------|--------|--------|---------|-----------|---------|
| BW [MHz] | RB Size | RB Offset | Mod | Lowest | Middle | Highest | ERP (dBm) | ERP (W) |
| 5 | 1 | 0 | QPSK | 24.45 | 24.47 | 24.41 | 21.31 | 0.1352 |
| 5 | 1 | 12 | | 24.34 | 24.17 | 24.25 | | |
| 5 | 1 | 24 | | 24.41 | 24.48 | 24.36 | | |
| 5 | 12 | 0 | | 23.49 | 23.44 | 23.55 | | |
| 5 | 12 | 7 | | 23.43 | 23.52 | 23.50 | | |
| 5 | 12 | 13 | | 23.45 | 23.54 | 23.42 | | |
| 5 | 25 | 0 | | 23.53 | 23.40 | 23.46 | | |
| 5 | 1 | 0 | 16-QAM | 23.71 | 23.57 | 23.70 | 20.66 | 0.1164 |
| 5 | 1 | 12 | | 23.83 | 23.67 | 23.72 | | |
| 5 | 1 | 24 | | 23.79 | 23.79 | 23.62 | | |
| 5 | 12 | 0 | | 22.41 | 22.57 | 22.55 | | |
| 5 | 12 | 7 | | 22.53 | 22.56 | 22.42 | | |
| 5 | 12 | 13 | | 22.59 | 22.39 | 22.54 | | |
| 5 | 25 | 0 | | 22.49 | 22.45 | 22.40 | | |
| 5 | 1 | 0 | 64-QAM | 22.77 | 22.63 | 22.52 | 19.60 | 0.0912 |
| 5 | 1 | 12 | | 22.49 | 22.54 | 22.69 | | |
| 5 | 1 | 24 | | 22.70 | 22.73 | 22.48 | | |
| 5 | 12 | 0 | | 21.36 | 21.38 | 21.40 | | |
| 5 | 12 | 7 | | 21.47 | 21.46 | 21.59 | | |
| 5 | 12 | 13 | | 21.58 | 21.48 | 21.46 | | |
| 5 | 25 | 0 | | 21.51 | 21.54 | 21.49 | | |
| 5 | 1 | 0 | 256-QAM | 19.87 | 19.76 | 19.61 | 16.70 | 0.0468 |
| 5 | 1 | 12 | | 19.30 | 19.26 | 19.21 | | |
| 5 | 1 | 24 | | 19.44 | 19.46 | 19.31 | | |
| 5 | 12 | 0 | | 19.66 | 19.54 | 19.58 | | |
| 5 | 12 | 7 | | 19.36 | 19.46 | 19.50 | | |
| 5 | 12 | 13 | | 19.44 | 19.24 | 19.36 | | |
| 5 | 25 | 0 | | 19.55 | 19.43 | 19.52 | | |
| Limit | ERP < 3W | | | Result | | | Pass | |



| LTE Band 12 Maximum Average Power [dBm] (GT - LC = -1.02 dB) | | | | | | | | |
|--|----------|-----------|---------|--------|--------|---------|-----------|---------|
| BW [MHz] | RB Size | RB Offset | Mod | Lowest | Middle | Highest | ERP (dBm) | ERP (W) |
| 3 | 1 | 0 | QPSK | 24.47 | 24.55 | 24.51 | 21.38 | 0.1374 |
| 3 | 1 | 8 | | 24.35 | 24.28 | 24.26 | | |
| 3 | 1 | 14 | | 24.49 | 24.38 | 24.44 | | |
| 3 | 8 | 0 | | 23.50 | 23.60 | 23.50 | | |
| 3 | 8 | 4 | | 23.47 | 23.44 | 23.50 | | |
| 3 | 8 | 7 | | 23.55 | 23.44 | 23.40 | | |
| 3 | 15 | 0 | | 23.39 | 23.44 | 23.50 | | |
| 3 | 1 | 0 | 16-QAM | 23.86 | 23.57 | 23.63 | 20.69 | 0.1172 |
| 3 | 1 | 8 | | 23.80 | 23.79 | 23.83 | | |
| 3 | 1 | 14 | | 23.73 | 23.69 | 23.72 | | |
| 3 | 8 | 0 | | 22.45 | 22.42 | 22.44 | | |
| 3 | 8 | 4 | | 22.44 | 22.38 | 22.43 | | |
| 3 | 8 | 7 | | 22.50 | 22.53 | 22.44 | | |
| 3 | 15 | 0 | | 22.37 | 22.37 | 22.45 | | |
| 3 | 1 | 0 | 64-QAM | 22.80 | 22.62 | 22.64 | 19.63 | 0.0918 |
| 3 | 1 | 8 | | 22.63 | 22.67 | 22.64 | | |
| 3 | 1 | 14 | | 22.60 | 22.65 | 22.55 | | |
| 3 | 8 | 0 | | 21.52 | 21.45 | 21.52 | | |
| 3 | 8 | 4 | | 21.57 | 21.59 | 21.41 | | |
| 3 | 8 | 7 | | 21.38 | 21.54 | 21.47 | | |
| 3 | 15 | 0 | | 21.52 | 21.52 | 21.49 | | |
| 3 | 1 | 0 | 256-QAM | 19.67 | 19.75 | 19.62 | 16.58 | 0.0455 |
| 3 | 1 | 8 | | 19.26 | 19.36 | 19.21 | | |
| 3 | 1 | 14 | | 19.60 | 19.54 | 19.42 | | |
| 3 | 8 | 0 | | 19.69 | 19.72 | 19.55 | | |
| 3 | 8 | 4 | | 19.34 | 19.32 | 19.44 | | |
| 3 | 8 | 7 | | 19.40 | 19.41 | 19.44 | | |
| 3 | 15 | 0 | | 19.58 | 19.51 | 19.49 | | |
| Limit | ERP < 3W | | | Result | | | Pass | |



| LTE Band 12 Maximum Average Power [dBm] (GT - LC = -1.02 dB) | | | | | | | | |
|--|----------|-----------|---------|--------|--------|---------|-----------|---------|
| BW [MHz] | RB Size | RB Offset | Mod | Lowest | Middle | Highest | ERP (dBm) | ERP (W) |
| 1.4 | 1 | 0 | QPSK | 24.54 | 24.55 | 24.46 | 21.38 | 0.1374 |
| 1.4 | 1 | 3 | | 24.34 | 24.26 | 24.36 | | |
| 1.4 | 1 | 5 | | 24.38 | 24.40 | 24.45 | | |
| 1.4 | 3 | 0 | | 24.48 | 24.50 | 24.50 | | |
| 1.4 | 3 | 1 | | 24.39 | 24.28 | 24.28 | | |
| 1.4 | 3 | 3 | | 24.51 | 24.38 | 24.31 | | |
| 1.4 | 6 | 0 | | 23.48 | 23.56 | 23.41 | | |
| 1.4 | 1 | 0 | 16-QAM | 23.40 | 23.40 | 23.42 | 20.73 | 0.1183 |
| 1.4 | 1 | 3 | | 23.43 | 23.42 | 23.38 | | |
| 1.4 | 1 | 5 | | 23.40 | 23.58 | 23.46 | | |
| 1.4 | 3 | 0 | | 23.90 | 23.60 | 23.71 | | |
| 1.4 | 3 | 1 | | 23.80 | 23.74 | 23.87 | | |
| 1.4 | 3 | 3 | | 23.87 | 23.72 | 23.57 | | |
| 1.4 | 6 | 0 | | 22.56 | 22.47 | 22.49 | | |
| 1.4 | 1 | 0 | 64-QAM | 22.45 | 22.44 | 22.42 | 19.63 | 0.0918 |
| 1.4 | 1 | 3 | | 22.39 | 22.47 | 22.52 | | |
| 1.4 | 1 | 5 | | 22.55 | 22.48 | 22.54 | | |
| 1.4 | 3 | 0 | | 22.68 | 22.52 | 22.55 | | |
| 1.4 | 3 | 1 | | 22.48 | 22.50 | 22.52 | | |
| 1.4 | 3 | 3 | | 22.68 | 22.80 | 22.50 | | |
| 1.4 | 6 | 0 | | 21.55 | 21.38 | 21.37 | | |
| 1.4 | 1 | 0 | 256-QAM | 19.74 | 19.74 | 19.69 | 16.61 | 0.0458 |
| 1.4 | 1 | 3 | | 19.35 | 19.17 | 19.34 | | |
| 1.4 | 1 | 5 | | 19.42 | 19.49 | 19.47 | | |
| 1.4 | 3 | 0 | | 19.78 | 19.70 | 19.67 | | |
| 1.4 | 3 | 1 | | 19.36 | 19.46 | 19.47 | | |
| 1.4 | 3 | 3 | | 19.32 | 19.39 | 19.48 | | |
| 1.4 | 6 | 0 | | 19.65 | 19.57 | 19.39 | | |
| Limit | ERP < 3W | | | Result | | | Pass | |



| LTE Band 13 Maximum Average Power [dBm] (GT - LC = -1.38 dB) | | | | | | | | |
|--|----------|-----------|---------|--------|--------|---------|-----------|---------|
| BW [MHz] | RB Size | RB Offset | Mod | Lowest | Middle | Highest | ERP (dBm) | ERP (W) |
| 10 | 1 | 0 | QPSK | | 24.32 | | 20.79 | 0.1199 |
| 10 | 1 | 25 | | | 24.20 | | | |
| 10 | 1 | 49 | | | 24.21 | | | |
| 10 | 25 | 0 | | | 23.39 | | | |
| 10 | 25 | 12 | | | 23.37 | | | |
| 10 | 25 | 25 | | | 23.34 | | | |
| 10 | 50 | 0 | | | 23.42 | | | |
| 10 | 1 | 0 | 16-QAM | | 23.46 | | 20.08 | 0.1019 |
| 10 | 1 | 25 | | | 23.61 | | | |
| 10 | 1 | 49 | | | 23.56 | | | |
| 10 | 25 | 0 | | | 22.38 | | | |
| 10 | 25 | 12 | | | 22.34 | | | |
| 10 | 25 | 25 | | | 22.31 | | | |
| 10 | 50 | 0 | | | 22.34 | | | |
| 10 | 1 | 0 | 64-QAM | | 22.63 | | 19.10 | 0.0813 |
| 10 | 1 | 25 | | | 22.63 | | | |
| 10 | 1 | 49 | | | 22.63 | | | |
| 10 | 25 | 0 | | | 21.37 | | | |
| 10 | 25 | 12 | | | 21.37 | | | |
| 10 | 25 | 25 | | | 21.37 | | | |
| 10 | 50 | 0 | | | 21.36 | | | |
| 10 | 1 | 0 | 256-QAM | | 19.60 | | 16.07 | 0.0405 |
| 10 | 1 | 25 | | | 19.40 | | | |
| 10 | 1 | 49 | | | 19.25 | | | |
| 10 | 25 | 0 | | | 19.42 | | | |
| 10 | 25 | 12 | | | 19.37 | | | |
| 10 | 25 | 25 | | | 19.33 | | | |
| 10 | 50 | 0 | | | 19.33 | | | |
| Limit | ERP < 3W | | | Result | | | Pass | |



| LTE Band 13 Maximum Average Power [dBm] (GT - LC = -1.38 dB) | | | | | | | | |
|--|----------|-----------|---------|--------|--------|---------|-----------|---------|
| BW [MHz] | RB Size | RB Offset | Mod | Lowest | Middle | Highest | ERP (dBm) | ERP (W) |
| 5 | 1 | 0 | QPSK | 24.28 | 24.12 | 24.20 | 20.75 | 0.1189 |
| 5 | 1 | 12 | | 24.20 | 24.04 | 24.04 | | |
| 5 | 1 | 24 | | 24.04 | 24.02 | 24.07 | | |
| 5 | 12 | 0 | | 23.20 | 23.35 | 23.39 | | |
| 5 | 12 | 7 | | 23.25 | 23.21 | 23.31 | | |
| 5 | 12 | 13 | | 23.16 | 23.32 | 23.26 | | |
| 5 | 25 | 0 | | 23.24 | 23.24 | 23.29 | | |
| 5 | 1 | 0 | 16-QAM | 23.46 | 23.41 | 23.31 | 20.08 | 0.1019 |
| 5 | 1 | 12 | | 23.61 | 23.45 | 23.57 | | |
| 5 | 1 | 24 | | 23.49 | 23.56 | 23.53 | | |
| 5 | 12 | 0 | | 22.19 | 22.23 | 22.38 | | |
| 5 | 12 | 7 | | 22.24 | 22.28 | 22.32 | | |
| 5 | 12 | 13 | | 22.25 | 22.21 | 22.17 | | |
| 5 | 25 | 0 | | 22.30 | 22.24 | 22.32 | | |
| 5 | 1 | 0 | 64-QAM | 22.46 | 22.48 | 22.54 | 19.09 | 0.0811 |
| 5 | 1 | 12 | | 22.57 | 22.62 | 22.60 | | |
| 5 | 1 | 24 | | 22.57 | 22.59 | 22.60 | | |
| 5 | 12 | 0 | | 21.17 | 21.27 | 21.30 | | |
| 5 | 12 | 7 | | 21.17 | 21.29 | 21.34 | | |
| 5 | 12 | 13 | | 21.33 | 21.36 | 21.26 | | |
| 5 | 25 | 0 | | 21.29 | 21.16 | 21.30 | | |
| 5 | 1 | 0 | 256-QAM | 19.56 | 19.50 | 19.48 | 16.03 | 0.0401 |
| 5 | 1 | 12 | | 19.39 | 19.38 | 19.34 | | |
| 5 | 1 | 24 | | 19.06 | 19.11 | 19.24 | | |
| 5 | 12 | 0 | | 19.23 | 19.38 | 19.41 | | |
| 5 | 12 | 7 | | 19.28 | 19.24 | 19.17 | | |
| 5 | 12 | 13 | | 19.16 | 19.16 | 19.14 | | |
| 5 | 25 | 0 | | 19.29 | 19.24 | 19.14 | | |
| Limit | ERP < 3W | | | Result | | | Pass | |



| LTE Band 17 Maximum Average Power [dBm] (GT - LC = -1.28 dB) | | | | | | | | |
|--|----------|-----------|---------|--------|--------|---------|-----------|---------|
| BW [MHz] | RB Size | RB Offset | Mod | Lowest | Middle | Highest | ERP (dBm) | ERP (W) |
| 10 | 1 | 0 | QPSK | 24.49 | 24.48 | 24.52 | 21.09 | 0.1285 |
| 10 | 1 | 25 | | 24.35 | 24.29 | 24.34 | | |
| 10 | 1 | 49 | | 24.45 | 24.42 | 24.42 | | |
| 10 | 25 | 0 | | 23.49 | 23.49 | 23.50 | | |
| 10 | 25 | 12 | | 23.49 | 23.47 | 23.45 | | |
| 10 | 25 | 25 | | 23.46 | 23.47 | 23.47 | | |
| 10 | 50 | 0 | | 23.48 | 23.48 | 23.49 | | |
| 10 | 1 | 0 | 16-QAM | 23.72 | 23.71 | 23.73 | 20.38 | 0.1091 |
| 10 | 1 | 25 | | 23.73 | 23.81 | 23.78 | | |
| 10 | 1 | 49 | | 23.68 | 23.70 | 23.64 | | |
| 10 | 25 | 0 | | 22.48 | 22.49 | 22.50 | | |
| 10 | 25 | 12 | | 22.49 | 22.50 | 22.49 | | |
| 10 | 25 | 25 | | 22.50 | 22.52 | 22.50 | | |
| 10 | 50 | 0 | | 22.46 | 22.47 | 22.47 | | |
| 10 | 1 | 0 | 64-QAM | 22.63 | 22.66 | 22.58 | 19.24 | 0.0839 |
| 10 | 1 | 25 | | 22.54 | 22.67 | 22.50 | | |
| 10 | 1 | 49 | | 22.63 | 22.62 | 22.51 | | |
| 10 | 25 | 0 | | 21.50 | 21.49 | 21.51 | | |
| 10 | 25 | 12 | | 21.52 | 21.51 | 21.51 | | |
| 10 | 25 | 25 | | 21.53 | 21.48 | 21.51 | | |
| 10 | 50 | 0 | | 21.50 | 21.48 | 21.49 | | |
| 10 | 1 | 0 | 256-QAM | 19.73 | 19.82 | 19.73 | 16.39 | 0.0436 |
| 10 | 1 | 25 | | 19.41 | 19.51 | 19.41 | | |
| 10 | 1 | 49 | | 19.50 | 19.62 | 19.53 | | |
| 10 | 25 | 0 | | 19.38 | 19.55 | 19.44 | | |
| 10 | 25 | 12 | | 19.29 | 19.41 | 19.25 | | |
| 10 | 25 | 25 | | 19.30 | 19.40 | 19.22 | | |
| 10 | 50 | 0 | | 19.38 | 19.48 | 19.34 | | |
| Limit | ERP < 3W | | | Result | | | Pass | |



| LTE Band 17 Maximum Average Power [dBm] (GT - LC = -1.28 dB) | | | | | | | | |
|--|----------|-----------|---------|--------|--------|---------|-----------|---------|
| BW [MHz] | RB Size | RB Offset | Mod | Lowest | Middle | Highest | ERP (dBm) | ERP (W) |
| 5 | 1 | 0 | QPSK | 24.42 | 24.30 | 24.43 | 21.00 | 0.1259 |
| 5 | 1 | 12 | | 24.17 | 24.09 | 24.24 | | |
| 5 | 1 | 24 | | 24.25 | 24.32 | 24.34 | | |
| 5 | 12 | 0 | | 23.37 | 23.45 | 23.38 | | |
| 5 | 12 | 7 | | 23.34 | 23.43 | 23.38 | | |
| 5 | 12 | 13 | | 23.26 | 23.28 | 23.45 | | |
| 5 | 25 | 0 | | 23.37 | 23.48 | 23.40 | | |
| 5 | 1 | 0 | 16-QAM | 23.69 | 23.71 | 23.71 | 20.30 | 0.1072 |
| 5 | 1 | 12 | | 23.72 | 23.66 | 23.73 | | |
| 5 | 1 | 24 | | 23.54 | 23.56 | 23.58 | | |
| 5 | 12 | 0 | | 22.38 | 22.31 | 22.39 | | |
| 5 | 12 | 7 | | 22.32 | 22.34 | 22.32 | | |
| 5 | 12 | 13 | | 22.43 | 22.34 | 22.33 | | |
| 5 | 25 | 0 | | 22.29 | 22.35 | 22.33 | | |
| 5 | 1 | 0 | 64-QAM | 22.62 | 22.59 | 22.44 | 19.19 | 0.0830 |
| 5 | 1 | 12 | | 22.37 | 22.51 | 22.41 | | |
| 5 | 1 | 24 | | 22.55 | 22.62 | 22.49 | | |
| 5 | 12 | 0 | | 21.38 | 21.32 | 21.31 | | |
| 5 | 12 | 7 | | 21.39 | 21.39 | 21.42 | | |
| 5 | 12 | 13 | | 21.39 | 21.31 | 21.48 | | |
| 5 | 25 | 0 | | 21.32 | 21.44 | 21.36 | | |
| 5 | 1 | 0 | 256-QAM | 19.71 | 19.68 | 19.61 | 16.28 | 0.0425 |
| 5 | 1 | 12 | | 19.28 | 19.32 | 19.25 | | |
| 5 | 1 | 24 | | 19.34 | 19.47 | 19.50 | | |
| 5 | 12 | 0 | | 19.31 | 19.41 | 19.39 | | |
| 5 | 12 | 7 | | 19.14 | 19.41 | 19.23 | | |
| 5 | 12 | 13 | | 19.25 | 19.30 | 19.13 | | |
| 5 | 25 | 0 | | 19.38 | 19.47 | 19.19 | | |
| Limit | ERP < 3W | | | Result | | | Pass | |



| LTE Band 26 (Part22H) Maximum Average Power [dBm] (GT - LC = -1.9 dB) | | | | | | | | |
|---|----------|-----------|---------|--------|--------|---------|-----------|---------|
| BW [MHz] | RB Size | RB Offset | Mod | Lowest | Middle | Highest | ERP (dBm) | ERP (W) |
| 15 | 1 | 0 | QPSK | 24.25 | 24.43 | 24.19 | 20.38 | 0.1091 |
| 15 | 1 | 37 | | 24.15 | 24.36 | 24.11 | | |
| 15 | 1 | 74 | | 24.22 | 24.34 | 24.13 | | |
| 15 | 36 | 0 | | 23.20 | 23.10 | 23.20 | | |
| 15 | 36 | 20 | | 23.18 | 22.96 | 23.17 | | |
| 15 | 36 | 39 | | 23.16 | 23.16 | 23.15 | | |
| 15 | 75 | 0 | | 23.16 | 23.21 | 23.16 | | |
| 15 | 1 | 0 | 16-QAM | 23.52 | 23.67 | 23.53 | 19.69 | 0.0931 |
| 15 | 1 | 37 | | 23.57 | 23.39 | 23.45 | | |
| 15 | 1 | 74 | | 23.52 | 23.74 | 23.41 | | |
| 15 | 36 | 0 | | 22.16 | 22.27 | 22.22 | | |
| 15 | 36 | 20 | | 22.20 | 22.32 | 22.18 | | |
| 15 | 36 | 39 | | 22.22 | 22.35 | 22.18 | | |
| 15 | 75 | 0 | | 22.18 | 22.02 | 22.21 | | |
| 15 | 1 | 0 | 64-QAM | 22.36 | 22.22 | 22.46 | 18.47 | 0.0703 |
| 15 | 1 | 37 | | 22.38 | 22.52 | 22.27 | | |
| 15 | 1 | 74 | | 22.51 | 22.26 | 22.20 | | |
| 15 | 36 | 0 | | 21.20 | 21.28 | 21.25 | | |
| 15 | 36 | 20 | | 21.24 | 21.32 | 21.20 | | |
| 15 | 36 | 39 | | 21.25 | 21.30 | 21.20 | | |
| 15 | 75 | 0 | | 21.16 | 21.09 | 21.18 | | |
| 15 | 1 | 0 | 256-QAM | 19.56 | 19.52 | 19.48 | 15.51 | 0.0356 |
| 15 | 1 | 37 | | 19.23 | 18.98 | 19.15 | | |
| 15 | 1 | 74 | | 19.17 | 18.88 | 18.99 | | |
| 15 | 36 | 0 | | 19.35 | 19.23 | 19.20 | | |
| 15 | 36 | 20 | | 19.10 | 19.10 | 19.00 | | |
| 15 | 36 | 39 | | 19.05 | 19.01 | 18.96 | | |
| 15 | 75 | 0 | | 19.24 | 19.20 | 19.16 | | |
| Limit | ERP < 7W | | | Result | | | Pass | |



| LTE Band 26 (Part22H) Maximum Average Power [dBm] (GT - LC = -1.9 dB) | | | | | | | | |
|---|----------|-----------|---------|--------|--------|---------|-----------|---------|
| BW [MHz] | RB Size | RB Offset | Mod | Lowest | Middle | Highest | ERP (dBm) | ERP (W) |
| 10 | 1 | 0 | QPSK | 24.11 | 23.99 | 24.07 | 20.15 | 0.1035 |
| 10 | 1 | 25 | | 24.20 | 24.12 | 23.95 | | |
| 10 | 1 | 49 | | 24.14 | 24.03 | 24.00 | | |
| 10 | 25 | 0 | | 23.15 | 22.99 | 23.10 | | |
| 10 | 25 | 12 | | 22.97 | 23.06 | 23.05 | | |
| 10 | 25 | 25 | | 23.17 | 23.01 | 23.08 | | |
| 10 | 50 | 0 | | 23.16 | 22.92 | 22.99 | | |
| 10 | 1 | 0 | 16-QAM | 23.57 | 23.38 | 23.47 | 19.57 | 0.0906 |
| 10 | 1 | 25 | | 23.62 | 23.53 | 23.30 | | |
| 10 | 1 | 49 | | 23.54 | 23.25 | 23.21 | | |
| 10 | 25 | 0 | | 22.02 | 22.01 | 22.12 | | |
| 10 | 25 | 12 | | 22.05 | 22.03 | 22.06 | | |
| 10 | 25 | 25 | | 22.08 | 22.10 | 22.00 | | |
| 10 | 50 | 0 | | 22.10 | 21.96 | 22.20 | | |
| 10 | 1 | 0 | 64-QAM | 22.18 | 22.27 | 22.39 | 18.34 | 0.0682 |
| 10 | 1 | 25 | | 22.31 | 22.34 | 22.22 | | |
| 10 | 1 | 49 | | 22.39 | 22.26 | 22.18 | | |
| 10 | 25 | 0 | | 21.14 | 21.21 | 21.17 | | |
| 10 | 25 | 12 | | 21.08 | 21.29 | 21.02 | | |
| 10 | 25 | 25 | | 20.97 | 21.11 | 21.16 | | |
| 10 | 50 | 0 | | 21.17 | 21.06 | 21.11 | | |
| 10 | 1 | 0 | 256-QAM | 19.26 | 19.32 | 19.43 | 15.38 | 0.0345 |
| 10 | 1 | 25 | | 19.19 | 19.14 | 19.12 | | |
| 10 | 1 | 49 | | 19.03 | 18.99 | 18.79 | | |
| 10 | 25 | 0 | | 19.15 | 19.37 | 19.13 | | |
| 10 | 25 | 12 | | 18.92 | 19.01 | 18.85 | | |
| 10 | 25 | 25 | | 18.75 | 18.90 | 18.86 | | |
| 10 | 50 | 0 | | 18.84 | 19.25 | 19.02 | | |
| Limit | ERP < 7W | | | Result | | | Pass | |



| LTE Band 26 (Part22H) Maximum Average Power [dBm] (GT - LC = -1.9 dB) | | | | | | | | |
|---|----------|-----------|---------|--------|--------|---------|-----------|---------|
| BW [MHz] | RB Size | RB Offset | Mod | Lowest | Middle | Highest | ERP (dBm) | ERP (W) |
| 5 | 1 | 0 | QPSK | 24.19 | 24.17 | 24.14 | 20.26 | 0.1062 |
| 5 | 1 | 12 | | 24.07 | 24.10 | 24.05 | | |
| 5 | 1 | 24 | | 24.21 | 24.31 | 24.10 | | |
| 5 | 12 | 0 | | 23.12 | 23.14 | 23.17 | | |
| 5 | 12 | 7 | | 23.10 | 23.00 | 22.98 | | |
| 5 | 12 | 13 | | 23.20 | 23.13 | 22.96 | | |
| 5 | 25 | 0 | | 23.05 | 22.88 | 23.11 | | |
| 5 | 1 | 0 | 16-QAM | 23.62 | 23.46 | 23.37 | 19.57 | 0.0906 |
| 5 | 1 | 12 | | 23.45 | 23.45 | 23.34 | | |
| 5 | 1 | 24 | | 23.44 | 23.51 | 23.39 | | |
| 5 | 12 | 0 | | 22.18 | 22.07 | 22.18 | | |
| 5 | 12 | 7 | | 22.12 | 22.11 | 22.02 | | |
| 5 | 12 | 13 | | 22.14 | 22.14 | 22.18 | | |
| 5 | 25 | 0 | | 21.96 | 22.08 | 22.08 | | |
| 5 | 1 | 0 | 64-QAM | 22.27 | 22.43 | 22.34 | 18.40 | 0.0692 |
| 5 | 1 | 12 | | 22.23 | 22.15 | 22.14 | | |
| 5 | 1 | 24 | | 22.41 | 22.45 | 22.17 | | |
| 5 | 12 | 0 | | 21.30 | 21.03 | 21.07 | | |
| 5 | 12 | 7 | | 21.02 | 21.26 | 21.04 | | |
| 5 | 12 | 13 | | 21.16 | 21.23 | 21.20 | | |
| 5 | 25 | 0 | | 21.11 | 21.04 | 21.17 | | |
| 5 | 1 | 0 | 256-QAM | 19.22 | 19.43 | 19.33 | 15.38 | 0.0345 |
| 5 | 1 | 12 | | 19.02 | 19.08 | 19.13 | | |
| 5 | 1 | 24 | | 19.06 | 19.07 | 18.85 | | |
| 5 | 12 | 0 | | 19.25 | 19.24 | 19.17 | | |
| 5 | 12 | 7 | | 18.92 | 19.10 | 18.80 | | |
| 5 | 12 | 13 | | 18.88 | 18.97 | 18.94 | | |
| 5 | 25 | 0 | | 19.06 | 19.02 | 19.05 | | |
| Limit | ERP < 7W | | | Result | | | Pass | |



| LTE Band 26 (Part22H) Maximum Average Power [dBm] (GT - LC = -1.9 dB) | | | | | | | | |
|---|----------|-----------|---------|--------|--------|---------|-----------|---------|
| BW [MHz] | RB Size | RB Offset | Mod | Lowest | Middle | Highest | ERP (dBm) | ERP (W) |
| 3 | 1 | 0 | QPSK | 24.27 | 24.25 | 24.04 | 20.22 | 0.1052 |
| 3 | 1 | 8 | | 24.05 | 24.03 | 24.01 | | |
| 3 | 1 | 14 | | 24.22 | 24.01 | 23.94 | | |
| 3 | 8 | 0 | | 22.94 | 23.19 | 23.13 | | |
| 3 | 8 | 4 | | 23.13 | 23.04 | 23.11 | | |
| 3 | 8 | 7 | | 23.08 | 23.06 | 23.11 | | |
| 3 | 15 | 0 | | 23.11 | 22.97 | 23.06 | | |
| 3 | 1 | 0 | 16-QAM | 23.50 | 23.45 | 23.47 | 19.46 | 0.0883 |
| 3 | 1 | 8 | | 23.46 | 23.50 | 23.41 | | |
| 3 | 1 | 14 | | 23.51 | 23.34 | 23.31 | | |
| 3 | 8 | 0 | | 22.12 | 22.02 | 22.11 | | |
| 3 | 8 | 4 | | 22.12 | 22.11 | 22.10 | | |
| 3 | 8 | 7 | | 22.14 | 21.93 | 22.09 | | |
| 3 | 15 | 0 | | 22.26 | 21.98 | 22.01 | | |
| 3 | 1 | 0 | 64-QAM | 22.21 | 22.29 | 22.36 | 18.44 | 0.0698 |
| 3 | 1 | 8 | | 22.35 | 22.33 | 22.22 | | |
| 3 | 1 | 14 | | 22.26 | 22.49 | 22.18 | | |
| 3 | 8 | 0 | | 21.02 | 21.19 | 21.20 | | |
| 3 | 8 | 4 | | 21.03 | 21.04 | 21.18 | | |
| 3 | 8 | 7 | | 21.10 | 21.09 | 21.08 | | |
| 3 | 15 | 0 | | 21.05 | 20.90 | 21.13 | | |
| 3 | 1 | 0 | 256-QAM | 19.27 | 19.47 | 19.31 | 15.42 | 0.0348 |
| 3 | 1 | 8 | | 18.99 | 19.07 | 19.03 | | |
| 3 | 1 | 14 | | 18.85 | 19.25 | 18.95 | | |
| 3 | 8 | 0 | | 18.97 | 19.30 | 19.07 | | |
| 3 | 8 | 4 | | 19.02 | 18.94 | 18.93 | | |
| 3 | 8 | 7 | | 18.80 | 18.83 | 18.83 | | |
| 3 | 15 | 0 | | 18.86 | 19.01 | 19.05 | | |
| Limit | ERP < 7W | | | Result | | | Pass | |



| LTE Band 26 (Part22H) Maximum Average Power [dBm] (GT - LC = -1.9 dB) | | | | | | | | |
|---|----------|-----------|---------|--------|--------|---------|-----------|---------|
| BW [MHz] | RB Size | RB Offset | Mod | Lowest | Middle | Highest | ERP (dBm) | ERP (W) |
| 1.4 | 1 | 0 | QPSK | 24.16 | 24.07 | 24.03 | 20.21 | 0.1050 |
| 1.4 | 1 | 3 | | 23.96 | 24.04 | 24.00 | | |
| 1.4 | 1 | 5 | | 24.22 | 23.94 | 23.97 | | |
| 1.4 | 3 | 0 | | 24.26 | 24.06 | 24.14 | | |
| 1.4 | 3 | 1 | | 24.24 | 23.90 | 23.99 | | |
| 1.4 | 3 | 3 | | 24.02 | 24.11 | 24.09 | | |
| 1.4 | 6 | 0 | | 23.12 | 23.20 | 23.00 | | |
| 1.4 | 1 | 0 | 16-QAM | 22.98 | 23.18 | 23.04 | 19.71 | 0.0935 |
| 1.4 | 1 | 3 | | 23.01 | 23.03 | 23.02 | | |
| 1.4 | 1 | 5 | | 23.15 | 23.22 | 23.07 | | |
| 1.4 | 3 | 0 | | 23.76 | 23.42 | 23.35 | | |
| 1.4 | 3 | 1 | | 23.32 | 23.59 | 23.44 | | |
| 1.4 | 3 | 3 | | 23.38 | 23.50 | 23.27 | | |
| 1.4 | 6 | 0 | | 22.00 | 22.24 | 22.16 | | |
| 1.4 | 1 | 0 | 64-QAM | 22.07 | 22.23 | 22.12 | 18.36 | 0.0685 |
| 1.4 | 1 | 3 | | 21.99 | 22.17 | 22.04 | | |
| 1.4 | 1 | 5 | | 22.00 | 22.08 | 22.16 | | |
| 1.4 | 3 | 0 | | 22.27 | 22.15 | 22.27 | | |
| 1.4 | 3 | 1 | | 22.15 | 22.25 | 22.17 | | |
| 1.4 | 3 | 3 | | 22.23 | 22.41 | 22.07 | | |
| 1.4 | 6 | 0 | | 21.20 | 21.08 | 21.05 | | |
| 1.4 | 1 | 0 | 256-QAM | 19.36 | 19.59 | 19.48 | 15.54 | 0.0358 |
| 1.4 | 1 | 3 | | 18.86 | 19.15 | 18.97 | | |
| 1.4 | 1 | 5 | | 18.81 | 19.11 | 18.87 | | |
| 1.4 | 3 | 0 | | 19.09 | 19.33 | 19.10 | | |
| 1.4 | 3 | 1 | | 18.97 | 18.95 | 18.85 | | |
| 1.4 | 3 | 3 | | 18.89 | 18.85 | 18.86 | | |
| 1.4 | 6 | 0 | | 19.05 | 19.22 | 19.01 | | |
| Limit | ERP < 7W | | | Result | | | Pass | |



| LTE Band 38 Maximum Average Power [dBm] (GT - LC = 0.9 dB) | | | | | | | | |
|--|-----------|-----------|---------|--------|--------|---------|------------|----------|
| BW [MHz] | RB Size | RB Offset | Mod | Lowest | Middle | Highest | EIRP (dBm) | EIRP (W) |
| 20 | 1 | 0 | QPSK | 24.55 | 24.64 | 24.60 | 25.54 | 0.3581 |
| 20 | 1 | 49 | | 24.51 | 24.50 | 24.47 | | |
| 20 | 1 | 99 | | 24.48 | 24.47 | 24.44 | | |
| 20 | 50 | 0 | | 23.56 | 23.56 | 23.54 | | |
| 20 | 50 | 24 | | 23.54 | 23.55 | 23.51 | | |
| 20 | 50 | 50 | | 23.50 | 23.53 | 23.50 | | |
| 20 | 100 | 0 | | 23.52 | 23.57 | 23.51 | | |
| 20 | 1 | 0 | 16-QAM | 23.71 | 23.71 | 23.63 | 24.61 | 0.2891 |
| 20 | 1 | 49 | | 23.68 | 23.56 | 23.60 | | |
| 20 | 1 | 99 | | 23.63 | 23.55 | 23.55 | | |
| 20 | 50 | 0 | | 22.58 | 22.60 | 22.52 | | |
| 20 | 50 | 24 | | 22.57 | 22.57 | 22.55 | | |
| 20 | 50 | 50 | | 22.54 | 22.58 | 22.54 | | |
| 20 | 100 | 0 | | 22.52 | 22.59 | 22.56 | | |
| 20 | 1 | 0 | 64-QAM | 22.46 | 22.56 | 22.49 | 23.46 | 0.2218 |
| 20 | 1 | 49 | | 22.41 | 22.42 | 22.48 | | |
| 20 | 1 | 99 | | 22.46 | 22.40 | 22.46 | | |
| 20 | 50 | 0 | | 21.60 | 21.61 | 21.54 | | |
| 20 | 50 | 24 | | 21.57 | 21.59 | 21.52 | | |
| 20 | 50 | 50 | | 21.53 | 21.53 | 21.49 | | |
| 20 | 100 | 0 | | 21.55 | 21.56 | 21.53 | | |
| 20 | 1 | 0 | 256-QAM | 19.48 | 19.75 | 19.87 | 20.77 | 0.1194 |
| 20 | 1 | 49 | | 19.15 | 19.44 | 19.55 | | |
| 20 | 1 | 99 | | 19.04 | 19.37 | 19.48 | | |
| 20 | 50 | 0 | | 17.45 | 17.74 | 17.78 | | |
| 20 | 50 | 24 | | 17.36 | 17.73 | 17.76 | | |
| 20 | 50 | 50 | | 17.32 | 17.64 | 17.67 | | |
| 20 | 100 | 0 | | 17.27 | 17.63 | 17.67 | | |
| Limit | EIRP < 2W | | | Result | | | Pass | |



| LTE Band 38 Maximum Average Power [dBm] (GT - LC = 0.9 dB) | | | | | | | | |
|--|-----------|-----------|---------|--------|--------|---------|------------|----------|
| BW [MHz] | RB Size | RB Offset | Mod | Lowest | Middle | Highest | EIRP (dBm) | EIRP (W) |
| 15 | 1 | 0 | QPSK | 24.38 | 24.56 | 24.58 | 25.48 | 0.3532 |
| 15 | 1 | 37 | | 24.38 | 24.41 | 24.47 | | |
| 15 | 1 | 74 | | 24.37 | 24.39 | 24.30 | | |
| 15 | 36 | 0 | | 23.39 | 23.39 | 23.43 | | |
| 15 | 36 | 20 | | 23.41 | 23.52 | 23.39 | | |
| 15 | 36 | 39 | | 23.42 | 23.42 | 23.33 | | |
| 15 | 75 | 0 | | 23.46 | 23.54 | 23.42 | | |
| 15 | 1 | 0 | 16-QAM | 23.63 | 23.52 | 23.63 | 24.53 | 0.2838 |
| 15 | 1 | 37 | | 23.50 | 23.42 | 23.46 | | |
| 15 | 1 | 74 | | 23.46 | 23.37 | 23.39 | | |
| 15 | 36 | 0 | | 22.49 | 22.48 | 22.51 | | |
| 15 | 36 | 20 | | 22.37 | 22.47 | 22.44 | | |
| 15 | 36 | 39 | | 22.46 | 22.44 | 22.54 | | |
| 15 | 75 | 0 | | 22.44 | 22.48 | 22.40 | | |
| 15 | 1 | 0 | 64-QAM | 22.35 | 22.39 | 22.31 | 23.32 | 0.2148 |
| 15 | 1 | 37 | | 22.41 | 22.24 | 22.42 | | |
| 15 | 1 | 74 | | 22.29 | 22.35 | 22.34 | | |
| 15 | 36 | 0 | | 21.51 | 21.54 | 21.46 | | |
| 15 | 36 | 20 | | 21.44 | 21.47 | 21.44 | | |
| 15 | 36 | 39 | | 21.48 | 21.44 | 21.40 | | |
| 15 | 75 | 0 | | 21.42 | 21.41 | 21.52 | | |
| 15 | 1 | 0 | 256-QAM | 19.46 | 19.68 | 19.84 | 20.74 | 0.1186 |
| 15 | 1 | 37 | | 19.06 | 19.33 | 19.36 | | |
| 15 | 1 | 74 | | 18.93 | 19.30 | 19.29 | | |
| 15 | 36 | 0 | | 17.31 | 17.74 | 17.73 | | |
| 15 | 36 | 20 | | 17.28 | 17.67 | 17.62 | | |
| 15 | 36 | 39 | | 17.28 | 17.53 | 17.48 | | |
| 15 | 75 | 0 | | 17.19 | 17.63 | 17.64 | | |
| Limit | EIRP < 2W | | | Result | | | Pass | |



| LTE Band 38 Maximum Average Power [dBm] (GT - LC = 0.9 dB) | | | | | | | | |
|--|-----------|-----------|---------|--------|--------|---------|------------|----------|
| BW [MHz] | RB Size | RB Offset | Mod | Lowest | Middle | Highest | EIRP (dBm) | EIRP (W) |
| 10 | 1 | 0 | QPSK | 24.42 | 24.51 | 24.45 | 25.41 | 0.3475 |
| 10 | 1 | 25 | | 24.32 | 24.43 | 24.28 | | |
| 10 | 1 | 49 | | 24.33 | 24.30 | 24.41 | | |
| 10 | 25 | 0 | | 23.40 | 23.47 | 23.37 | | |
| 10 | 25 | 12 | | 23.52 | 23.42 | 23.37 | | |
| 10 | 25 | 25 | | 23.46 | 23.40 | 23.33 | | |
| 10 | 50 | 0 | | 23.38 | 23.52 | 23.50 | | |
| 10 | 1 | 0 | 16-QAM | 23.70 | 23.62 | 23.49 | 24.60 | 0.2884 |
| 10 | 1 | 25 | | 23.51 | 23.36 | 23.55 | | |
| 10 | 1 | 49 | | 23.58 | 23.45 | 23.52 | | |
| 10 | 25 | 0 | | 22.48 | 22.48 | 22.44 | | |
| 10 | 25 | 12 | | 22.39 | 22.44 | 22.48 | | |
| 10 | 25 | 25 | | 22.42 | 22.55 | 22.46 | | |
| 10 | 50 | 0 | | 22.39 | 22.39 | 22.56 | | |
| 10 | 1 | 0 | 64-QAM | 22.26 | 22.36 | 22.46 | 23.36 | 0.2168 |
| 10 | 1 | 25 | | 22.22 | 22.36 | 22.39 | | |
| 10 | 1 | 49 | | 22.41 | 22.21 | 22.43 | | |
| 10 | 25 | 0 | | 21.43 | 21.61 | 21.44 | | |
| 10 | 25 | 12 | | 21.57 | 21.53 | 21.35 | | |
| 10 | 25 | 25 | | 21.33 | 21.49 | 21.41 | | |
| 10 | 50 | 0 | | 21.45 | 21.40 | 21.42 | | |
| 10 | 1 | 0 | 256-QAM | 19.46 | 19.70 | 19.79 | 20.69 | 0.1172 |
| 10 | 1 | 25 | | 19.03 | 19.40 | 19.55 | | |
| 10 | 1 | 49 | | 18.96 | 19.30 | 19.45 | | |
| 10 | 25 | 0 | | 17.28 | 17.58 | 17.71 | | |
| 10 | 25 | 12 | | 17.36 | 17.60 | 17.76 | | |
| 10 | 25 | 25 | | 17.32 | 17.58 | 17.51 | | |
| 10 | 50 | 0 | | 17.21 | 17.56 | 17.62 | | |
| Limit | EIRP < 2W | | | Result | | | Pass | |



| LTE Band 38 Maximum Average Power [dBm] (GT - LC = 0.9 dB) | | | | | | | | |
|--|-----------|-----------|---------|--------|--------|---------|------------|----------|
| BW [MHz] | RB Size | RB Offset | Mod | Lowest | Middle | Highest | EIRP (dBm) | EIRP (W) |
| 5 | 1 | 0 | QPSK | 24.54 | 24.49 | 24.50 | 25.44 | 0.3499 |
| 5 | 1 | 12 | | 24.45 | 24.34 | 24.37 | | |
| 5 | 1 | 24 | | 24.46 | 24.32 | 24.29 | | |
| 5 | 12 | 0 | | 23.39 | 23.47 | 23.39 | | |
| 5 | 12 | 7 | | 23.49 | 23.53 | 23.32 | | |
| 5 | 12 | 13 | | 23.31 | 23.44 | 23.30 | | |
| 5 | 25 | 0 | | 23.43 | 23.42 | 23.48 | | |
| 5 | 1 | 0 | 16-QAM | 23.61 | 23.62 | 23.53 | 24.57 | 0.2864 |
| 5 | 1 | 12 | | 23.67 | 23.43 | 23.41 | | |
| 5 | 1 | 24 | | 23.47 | 23.42 | 23.36 | | |
| 5 | 12 | 0 | | 22.43 | 22.41 | 22.32 | | |
| 5 | 12 | 7 | | 22.56 | 22.56 | 22.51 | | |
| 5 | 12 | 13 | | 22.44 | 22.51 | 22.39 | | |
| 5 | 25 | 0 | | 22.34 | 22.40 | 22.52 | | |
| 5 | 1 | 0 | 64-QAM | 22.29 | 22.43 | 22.40 | 23.33 | 0.2153 |
| 5 | 1 | 12 | | 22.39 | 22.28 | 22.38 | | |
| 5 | 1 | 24 | | 22.41 | 22.32 | 22.38 | | |
| 5 | 12 | 0 | | 21.47 | 21.51 | 21.50 | | |
| 5 | 12 | 7 | | 21.42 | 21.55 | 21.52 | | |
| 5 | 12 | 13 | | 21.43 | 21.42 | 21.39 | | |
| 5 | 25 | 0 | | 21.52 | 21.51 | 21.52 | | |
| 5 | 1 | 0 | 256-QAM | 19.42 | 19.68 | 19.78 | 20.68 | 0.1169 |
| 5 | 1 | 12 | | 19.03 | 19.30 | 19.38 | | |
| 5 | 1 | 24 | | 18.87 | 19.32 | 19.44 | | |
| 5 | 12 | 0 | | 17.35 | 17.65 | 17.65 | | |
| 5 | 12 | 7 | | 17.30 | 17.64 | 17.75 | | |
| 5 | 12 | 13 | | 17.22 | 17.45 | 17.48 | | |
| 5 | 25 | 0 | | 17.19 | 17.44 | 17.47 | | |
| Limit | EIRP < 2W | | | Result | | | Pass | |



| LTE Band 38(HPUE) Maximum Average Power [dBm] (GT - LC = 0.9 dB) | | | | | | | | |
|--|-----------|-----------|---------|--------|--------|---------|------------|----------|
| BW [MHz] | RB Size | RB Offset | Mod | Lowest | Middle | Highest | EIRP (dBm) | EIRP (W) |
| 20 | 1 | 0 | QPSK | 26.29 | 26.28 | 26.27 | 27.19 | 0.5236 |
| 20 | 1 | 49 | | 26.21 | 26.25 | 26.17 | | |
| 20 | 1 | 99 | | 26.10 | 26.13 | 26.14 | | |
| 20 | 50 | 0 | | 25.35 | 25.28 | 25.26 | | |
| 20 | 50 | 24 | | 25.27 | 25.27 | 25.23 | | |
| 20 | 50 | 50 | | 25.24 | 25.22 | 25.23 | | |
| 20 | 100 | 0 | | 25.40 | 25.25 | 25.33 | | |
| 20 | 1 | 0 | 16-QAM | 25.62 | 25.70 | 25.53 | 26.60 | 0.4571 |
| 20 | 1 | 49 | | 25.62 | 25.43 | 25.36 | | |
| 20 | 1 | 99 | | 25.57 | 25.39 | 25.36 | | |
| 20 | 50 | 0 | | 24.26 | 24.37 | 24.23 | | |
| 20 | 50 | 24 | | 24.25 | 24.22 | 24.23 | | |
| 20 | 50 | 50 | | 24.22 | 24.23 | 24.22 | | |
| 20 | 100 | 0 | | 24.26 | 24.29 | 24.28 | | |
| 20 | 1 | 0 | 64-QAM | 24.26 | 24.18 | 24.14 | 25.28 | 0.3373 |
| 20 | 1 | 49 | | 24.38 | 24.09 | 24.10 | | |
| 20 | 1 | 99 | | 24.23 | 24.14 | 24.10 | | |
| 20 | 50 | 0 | | 23.29 | 23.33 | 23.27 | | |
| 20 | 50 | 24 | | 23.25 | 23.28 | 23.22 | | |
| 20 | 50 | 50 | | 23.22 | 23.24 | 23.21 | | |
| 20 | 100 | 0 | | 23.26 | 23.28 | 23.26 | | |
| 20 | 1 | 0 | 256-QAM | 21.47 | 21.50 | 21.49 | 22.40 | 0.1738 |
| 20 | 1 | 49 | | 21.33 | 21.40 | 21.39 | | |
| 20 | 1 | 99 | | 21.13 | 21.20 | 21.16 | | |
| 20 | 50 | 0 | | 19.36 | 19.43 | 19.38 | | |
| 20 | 50 | 24 | | 19.29 | 19.39 | 19.32 | | |
| 20 | 50 | 50 | | 19.22 | 19.32 | 19.23 | | |
| 20 | 100 | 0 | | 19.27 | 19.30 | 19.28 | | |
| Limit | EIRP < 2W | | | Result | | | Pass | |



| LTE Band 38(HPUE) Maximum Average Power [dBm] (GT - LC = 0.9 dB) | | | | | | | | |
|--|-----------|-----------|---------|--------|--------|---------|------------|----------|
| BW [MHz] | RB Size | RB Offset | Mod | Lowest | Middle | Highest | EIRP (dBm) | EIRP (W) |
| 15 | 1 | 0 | QPSK | 26.15 | 26.13 | 26.27 | 27.17 | 0.5212 |
| 15 | 1 | 37 | | 26.11 | 26.08 | 25.97 | | |
| 15 | 1 | 74 | | 26.10 | 26.10 | 26.07 | | |
| 15 | 36 | 0 | | 25.33 | 25.20 | 25.07 | | |
| 15 | 36 | 20 | | 25.12 | 25.25 | 25.22 | | |
| 15 | 36 | 39 | | 25.09 | 25.07 | 25.07 | | |
| 15 | 75 | 0 | | 25.23 | 25.24 | 25.27 | | |
| 15 | 1 | 0 | 16-QAM | 25.62 | 25.56 | 25.53 | 26.52 | 0.4487 |
| 15 | 1 | 37 | | 25.47 | 25.31 | 25.19 | | |
| 15 | 1 | 74 | | 25.43 | 25.27 | 25.19 | | |
| 15 | 36 | 0 | | 24.17 | 24.25 | 24.20 | | |
| 15 | 36 | 20 | | 24.15 | 24.11 | 24.21 | | |
| 15 | 36 | 39 | | 24.05 | 24.17 | 24.12 | | |
| 15 | 75 | 0 | | 24.16 | 24.24 | 24.13 | | |
| 15 | 1 | 0 | 64-QAM | 24.14 | 24.15 | 23.94 | 25.25 | 0.3350 |
| 15 | 1 | 37 | | 24.35 | 23.94 | 23.96 | | |
| 15 | 1 | 74 | | 24.03 | 24.06 | 24.06 | | |
| 15 | 36 | 0 | | 23.13 | 23.26 | 23.07 | | |
| 15 | 36 | 20 | | 23.17 | 23.11 | 23.18 | | |
| 15 | 36 | 39 | | 23.13 | 23.05 | 23.10 | | |
| 15 | 75 | 0 | | 23.06 | 23.19 | 23.16 | | |
| 15 | 1 | 0 | 256-QAM | 21.44 | 21.50 | 21.32 | 22.40 | 0.1738 |
| 15 | 1 | 37 | | 21.27 | 21.25 | 21.22 | | |
| 15 | 1 | 74 | | 21.03 | 21.03 | 21.01 | | |
| 15 | 36 | 0 | | 19.32 | 19.36 | 19.23 | | |
| 15 | 36 | 20 | | 19.15 | 19.22 | 19.26 | | |
| 15 | 36 | 39 | | 19.11 | 19.23 | 19.08 | | |
| 15 | 75 | 0 | | 19.22 | 19.29 | 19.22 | | |
| Limit | EIRP < 2W | | | Result | | | Pass | |



| LTE Band 38(HPUE) Maximum Average Power [dBm] (GT - LC = 0.9 dB) | | | | | | | | |
|--|-----------|-----------|---------|--------|--------|---------|------------|----------|
| BW [MHz] | RB Size | RB Offset | Mod | Lowest | Middle | Highest | EIRP (dBm) | EIRP (W) |
| 10 | 1 | 0 | QPSK | 26.28 | 26.28 | 26.12 | 27.18 | 0.5224 |
| 10 | 1 | 25 | | 26.07 | 26.15 | 26.14 | | |
| 10 | 1 | 49 | | 26.06 | 26.07 | 26.04 | | |
| 10 | 25 | 0 | | 25.28 | 25.21 | 25.07 | | |
| 10 | 25 | 12 | | 25.08 | 25.26 | 25.13 | | |
| 10 | 25 | 25 | | 25.19 | 25.21 | 25.07 | | |
| 10 | 50 | 0 | | 25.21 | 25.23 | 25.33 | | |
| 10 | 1 | 0 | 16-QAM | 25.46 | 25.59 | 25.41 | 26.49 | 0.4457 |
| 10 | 1 | 25 | | 25.52 | 25.41 | 25.31 | | |
| 10 | 1 | 49 | | 25.42 | 25.21 | 25.26 | | |
| 10 | 25 | 0 | | 24.10 | 24.34 | 24.06 | | |
| 10 | 25 | 12 | | 24.16 | 24.14 | 24.04 | | |
| 10 | 25 | 25 | | 24.04 | 24.14 | 24.15 | | |
| 10 | 50 | 0 | | 24.23 | 24.15 | 24.15 | | |
| 10 | 1 | 0 | 64-QAM | 24.21 | 24.03 | 23.97 | 25.17 | 0.3289 |
| 10 | 1 | 25 | | 24.27 | 23.94 | 23.98 | | |
| 10 | 1 | 49 | | 24.18 | 24.11 | 23.98 | | |
| 10 | 25 | 0 | | 23.20 | 23.13 | 23.23 | | |
| 10 | 25 | 12 | | 23.07 | 23.20 | 23.05 | | |
| 10 | 25 | 25 | | 23.18 | 23.13 | 23.18 | | |
| 10 | 50 | 0 | | 23.26 | 23.18 | 23.15 | | |
| 10 | 1 | 0 | 256-QAM | 21.47 | 21.49 | 21.31 | 22.39 | 0.1734 |
| 10 | 1 | 25 | | 21.25 | 21.20 | 21.32 | | |
| 10 | 1 | 49 | | 21.13 | 21.00 | 20.96 | | |
| 10 | 25 | 0 | | 19.22 | 19.29 | 19.32 | | |
| 10 | 25 | 12 | | 19.16 | 19.31 | 19.31 | | |
| 10 | 25 | 25 | | 19.21 | 19.24 | 19.16 | | |
| 10 | 50 | 0 | | 19.21 | 19.22 | 19.20 | | |
| Limit | EIRP < 2W | | | Result | | | Pass | |



| LTE Band 38(HPUE) Maximum Average Power [dBm] (GT - LC = 0.9 dB) | | | | | | | | |
|--|-----------|-----------|---------|--------|--------|---------|------------|----------|
| BW [MHz] | RB Size | RB Offset | Mod | Lowest | Middle | Highest | EIRP (dBm) | EIRP (W) |
| 5 | 1 | 0 | QPSK | 26.27 | 26.15 | 26.12 | 27.17 | 0.5212 |
| 5 | 1 | 12 | | 26.06 | 26.09 | 26.14 | | |
| 5 | 1 | 24 | | 25.94 | 26.02 | 26.05 | | |
| 5 | 12 | 0 | | 25.26 | 25.25 | 25.22 | | |
| 5 | 12 | 7 | | 25.21 | 25.08 | 25.14 | | |
| 5 | 12 | 13 | | 25.05 | 25.12 | 25.04 | | |
| 5 | 25 | 0 | | 25.20 | 25.05 | 25.27 | | |
| 5 | 1 | 0 | 16-QAM | 25.47 | 25.52 | 25.33 | 26.47 | 0.4436 |
| 5 | 1 | 12 | | 25.49 | 25.39 | 25.30 | | |
| 5 | 1 | 24 | | 25.57 | 25.19 | 25.35 | | |
| 5 | 12 | 0 | | 24.19 | 24.30 | 24.22 | | |
| 5 | 12 | 7 | | 24.15 | 24.16 | 24.04 | | |
| 5 | 12 | 13 | | 24.03 | 24.09 | 24.22 | | |
| 5 | 25 | 0 | | 24.11 | 24.27 | 24.11 | | |
| 5 | 1 | 0 | 64-QAM | 24.18 | 24.06 | 24.13 | 25.13 | 0.3258 |
| 5 | 1 | 12 | | 24.21 | 24.04 | 23.95 | | |
| 5 | 1 | 24 | | 24.23 | 24.09 | 23.93 | | |
| 5 | 12 | 0 | | 23.28 | 23.31 | 23.20 | | |
| 5 | 12 | 7 | | 23.18 | 23.14 | 23.11 | | |
| 5 | 12 | 13 | | 23.05 | 23.18 | 23.09 | | |
| 5 | 25 | 0 | | 23.20 | 23.24 | 23.07 | | |
| 5 | 1 | 0 | 256-QAM | 21.40 | 21.30 | 21.32 | 22.30 | 0.1698 |
| 5 | 1 | 12 | | 21.33 | 21.26 | 21.22 | | |
| 5 | 1 | 24 | | 20.93 | 21.09 | 21.13 | | |
| 5 | 12 | 0 | | 19.24 | 19.36 | 19.24 | | |
| 5 | 12 | 7 | | 19.15 | 19.39 | 19.12 | | |
| 5 | 12 | 13 | | 19.19 | 19.27 | 19.23 | | |
| 5 | 25 | 0 | | 19.07 | 19.27 | 19.08 | | |
| Limit | EIRP < 2W | | | Result | | | Pass | |



| LTE Band 41 Maximum Average Power [dBm] (GT - LC = 0.84 dB) | | | | | | | | |
|---|-----------|-----------|---------|--------|--------|---------|------------|----------|
| BW [MHz] | RB Size | RB Offset | Mod | Lowest | Middle | Highest | EIRP (dBm) | EIRP (W) |
| 20 | 1 | 0 | QPSK | 24.31 | 24.35 | 24.12 | 25.19 | 0.3304 |
| 20 | 1 | 49 | | 24.24 | 24.32 | 24.10 | | |
| 20 | 1 | 99 | | 24.22 | 24.23 | 24.13 | | |
| 20 | 50 | 0 | | 23.30 | 23.31 | 23.13 | | |
| 20 | 50 | 24 | | 23.29 | 23.24 | 23.08 | | |
| 20 | 50 | 50 | | 23.29 | 23.22 | 23.12 | | |
| 20 | 100 | 0 | | 23.28 | 23.30 | 23.08 | | |
| 20 | 1 | 0 | 16-QAM | 23.37 | 23.40 | 23.21 | 24.24 | 0.2655 |
| 20 | 1 | 49 | | 23.25 | 23.30 | 23.17 | | |
| 20 | 1 | 99 | | 23.25 | 23.26 | 23.13 | | |
| 20 | 50 | 0 | | 22.29 | 22.28 | 22.10 | | |
| 20 | 50 | 24 | | 22.27 | 22.31 | 22.14 | | |
| 20 | 50 | 50 | | 22.24 | 22.27 | 22.14 | | |
| 20 | 100 | 0 | | 22.25 | 22.30 | 22.16 | | |
| 20 | 1 | 0 | 64-QAM | 22.22 | 22.01 | 21.68 | 23.06 | 0.2023 |
| 20 | 1 | 49 | | 22.02 | 21.96 | 21.72 | | |
| 20 | 1 | 99 | | 22.11 | 21.91 | 21.80 | | |
| 20 | 50 | 0 | | 21.29 | 21.33 | 21.11 | | |
| 20 | 50 | 24 | | 21.30 | 21.28 | 21.12 | | |
| 20 | 50 | 50 | | 21.27 | 21.26 | 21.18 | | |
| 20 | 100 | 0 | | 21.29 | 21.24 | 21.17 | | |
| 20 | 1 | 0 | 256-QAM | 19.41 | 19.45 | 18.92 | 20.29 | 0.1069 |
| 20 | 1 | 49 | | 19.08 | 19.16 | 18.61 | | |
| 20 | 1 | 99 | | 18.92 | 19.05 | 18.46 | | |
| 20 | 50 | 0 | | 17.33 | 17.42 | 16.80 | | |
| 20 | 50 | 24 | | 17.34 | 17.40 | 16.81 | | |
| 20 | 50 | 50 | | 17.30 | 17.34 | 16.74 | | |
| 20 | 100 | 0 | | 17.23 | 17.33 | 16.79 | | |
| Limit | EIRP < 2W | | | Result | | | Pass | |



| LTE Band 41 Maximum Average Power [dBm] (GT - LC = 0.84 dB) | | | | | | | | |
|---|-----------|-----------|---------|--------|--------|---------|------------|----------|
| BW [MHz] | RB Size | RB Offset | Mod | Lowest | Middle | Highest | EIRP (dBm) | EIRP (W) |
| 15 | 1 | 0 | QPSK | 24.29 | 24.26 | 24.09 | 25.13 | 0.3258 |
| 15 | 1 | 37 | | 24.12 | 24.16 | 23.92 | | |
| 15 | 1 | 74 | | 24.10 | 24.11 | 24.02 | | |
| 15 | 36 | 0 | | 23.14 | 23.28 | 23.10 | | |
| 15 | 36 | 20 | | 23.09 | 23.11 | 23.07 | | |
| 15 | 36 | 39 | | 23.12 | 23.14 | 23.06 | | |
| 15 | 75 | 0 | | 23.10 | 23.24 | 22.92 | | |
| 15 | 1 | 0 | 16-QAM | 23.28 | 23.31 | 23.19 | 24.15 | 0.2600 |
| 15 | 1 | 37 | | 23.24 | 23.27 | 23.15 | | |
| 15 | 1 | 74 | | 23.13 | 23.20 | 22.93 | | |
| 15 | 36 | 0 | | 22.20 | 22.14 | 22.05 | | |
| 15 | 36 | 20 | | 22.16 | 22.11 | 22.10 | | |
| 15 | 36 | 39 | | 22.06 | 22.17 | 21.95 | | |
| 15 | 75 | 0 | | 22.20 | 22.19 | 22.09 | | |
| 15 | 1 | 0 | 64-QAM | 22.03 | 22.00 | 21.57 | 22.87 | 0.1936 |
| 15 | 1 | 37 | | 21.91 | 21.95 | 21.63 | | |
| 15 | 1 | 74 | | 21.94 | 21.91 | 21.68 | | |
| 15 | 36 | 0 | | 21.09 | 21.16 | 21.02 | | |
| 15 | 36 | 20 | | 21.22 | 21.21 | 21.12 | | |
| 15 | 36 | 39 | | 21.13 | 21.06 | 21.07 | | |
| 15 | 75 | 0 | | 21.12 | 21.21 | 21.14 | | |
| 15 | 1 | 0 | 256-QAM | 19.33 | 19.41 | 18.86 | 20.25 | 0.1059 |
| 15 | 1 | 37 | | 18.96 | 19.06 | 18.58 | | |
| 15 | 1 | 74 | | 18.82 | 19.02 | 18.41 | | |
| 15 | 36 | 0 | | 17.27 | 17.32 | 16.73 | | |
| 15 | 36 | 20 | | 17.27 | 17.32 | 16.68 | | |
| 15 | 36 | 39 | | 17.14 | 17.23 | 16.54 | | |
| 15 | 75 | 0 | | 17.11 | 17.15 | 16.59 | | |
| Limit | EIRP < 2W | | | Result | | | Pass | |



| LTE Band 41 Maximum Average Power [dBm] (GT - LC = 0.84 dB) | | | | | | | | |
|---|-----------|-----------|---------|--------|--------|---------|------------|----------|
| BW [MHz] | RB Size | RB Offset | Mod | Lowest | Middle | Highest | EIRP (dBm) | EIRP (W) |
| 10 | 1 | 0 | QPSK | 24.13 | 24.20 | 23.96 | 25.08 | 0.3221 |
| 10 | 1 | 25 | | 24.24 | 24.17 | 23.97 | | |
| 10 | 1 | 49 | | 24.02 | 24.23 | 23.98 | | |
| 10 | 25 | 0 | | 23.15 | 23.26 | 23.00 | | |
| 10 | 25 | 12 | | 23.13 | 23.11 | 22.99 | | |
| 10 | 25 | 25 | | 23.14 | 23.02 | 22.97 | | |
| 10 | 50 | 0 | | 23.24 | 23.14 | 22.91 | | |
| 10 | 1 | 0 | 16-QAM | 23.21 | 23.29 | 23.01 | 24.13 | 0.2588 |
| 10 | 1 | 25 | | 23.18 | 23.23 | 23.01 | | |
| 10 | 1 | 49 | | 23.17 | 23.13 | 23.08 | | |
| 10 | 25 | 0 | | 22.13 | 22.21 | 22.01 | | |
| 10 | 25 | 12 | | 22.08 | 22.22 | 22.09 | | |
| 10 | 25 | 25 | | 22.13 | 22.09 | 22.14 | | |
| 10 | 50 | 0 | | 22.05 | 22.21 | 22.09 | | |
| 10 | 1 | 0 | 64-QAM | 22.07 | 21.81 | 21.65 | 22.91 | 0.1954 |
| 10 | 1 | 25 | | 21.99 | 21.94 | 21.58 | | |
| 10 | 1 | 49 | | 22.03 | 21.74 | 21.63 | | |
| 10 | 25 | 0 | | 21.25 | 21.27 | 20.92 | | |
| 10 | 25 | 12 | | 21.12 | 21.19 | 21.07 | | |
| 10 | 25 | 25 | | 21.12 | 21.14 | 21.17 | | |
| 10 | 50 | 0 | | 21.13 | 21.23 | 21.08 | | |
| 10 | 1 | 0 | 256-QAM | 19.26 | 19.28 | 18.75 | 20.12 | 0.1028 |
| 10 | 1 | 25 | | 18.88 | 19.05 | 18.43 | | |
| 10 | 1 | 49 | | 18.80 | 19.01 | 18.41 | | |
| 10 | 25 | 0 | | 17.18 | 17.42 | 16.76 | | |
| 10 | 25 | 12 | | 17.22 | 17.22 | 16.73 | | |
| 10 | 25 | 25 | | 17.30 | 17.20 | 16.59 | | |
| 10 | 50 | 0 | | 17.08 | 17.17 | 16.73 | | |
| Limit | EIRP < 2W | | | Result | | | Pass | |



| LTE Band 41 Maximum Average Power [dBm] (GT - LC = 0.84 dB) | | | | | | | | |
|---|-----------|-----------|---------|--------|--------|---------|------------|----------|
| BW [MHz] | RB Size | RB Offset | Mod | Lowest | Middle | Highest | EIRP (dBm) | EIRP (W) |
| 5 | 1 | 0 | QPSK | 24.16 | 24.30 | 24.04 | 25.14 | 0.3266 |
| 5 | 1 | 12 | | 24.04 | 24.30 | 23.94 | | |
| 5 | 1 | 24 | | 24.07 | 24.16 | 23.99 | | |
| 5 | 12 | 0 | | 23.17 | 23.17 | 23.02 | | |
| 5 | 12 | 7 | | 23.10 | 23.12 | 23.07 | | |
| 5 | 12 | 13 | | 23.15 | 23.22 | 23.03 | | |
| 5 | 25 | 0 | | 23.17 | 23.30 | 22.93 | | |
| 5 | 1 | 0 | 16-QAM | 23.21 | 23.27 | 23.04 | 24.14 | 0.2594 |
| 5 | 1 | 12 | | 23.08 | 23.30 | 23.10 | | |
| 5 | 1 | 24 | | 23.06 | 23.10 | 23.11 | | |
| 5 | 12 | 0 | | 22.29 | 22.19 | 22.08 | | |
| 5 | 12 | 7 | | 22.12 | 22.20 | 21.98 | | |
| 5 | 12 | 13 | | 22.19 | 22.10 | 22.10 | | |
| 5 | 25 | 0 | | 22.14 | 22.19 | 22.02 | | |
| 5 | 1 | 0 | 64-QAM | 22.09 | 21.95 | 21.64 | 22.93 | 0.1963 |
| 5 | 1 | 12 | | 22.00 | 21.88 | 21.58 | | |
| 5 | 1 | 24 | | 21.96 | 21.82 | 21.71 | | |
| 5 | 12 | 0 | | 21.18 | 21.29 | 21.03 | | |
| 5 | 12 | 7 | | 21.10 | 21.25 | 21.06 | | |
| 5 | 12 | 13 | | 21.25 | 21.11 | 21.01 | | |
| 5 | 25 | 0 | | 21.18 | 21.12 | 21.12 | | |
| 5 | 1 | 0 | 256-QAM | 19.23 | 19.32 | 18.74 | 20.16 | 0.1038 |
| 5 | 1 | 12 | | 19.04 | 19.02 | 18.59 | | |
| 5 | 1 | 24 | | 18.92 | 18.91 | 18.42 | | |
| 5 | 12 | 0 | | 17.15 | 17.36 | 16.76 | | |
| 5 | 12 | 7 | | 17.22 | 17.39 | 16.76 | | |
| 5 | 12 | 13 | | 17.24 | 17.31 | 16.70 | | |
| 5 | 25 | 0 | | 17.15 | 17.15 | 16.67 | | |
| Limit | EIRP < 2W | | | Result | | | Pass | |



| LTE Band 41(HPUE) Maximum Average Power [dBm] (GT - LC = 0.84 dB) | | | | | | | | |
|---|-----------|-----------|---------|--------|--------|---------|------------|----------|
| BW [MHz] | RB Size | RB Offset | Mod | Lowest | Middle | Highest | EIRP (dBm) | EIRP (W) |
| 20 | 1 | 0 | QPSK | 26.33 | 26.29 | 26.17 | 27.17 | 0.5212 |
| 20 | 1 | 49 | | 26.19 | 26.22 | 26.06 | | |
| 20 | 1 | 99 | | 26.20 | 26.14 | 26.06 | | |
| 20 | 50 | 0 | | 25.36 | 25.31 | 25.21 | | |
| 20 | 50 | 24 | | 25.33 | 25.26 | 25.19 | | |
| 20 | 50 | 50 | | 25.33 | 25.25 | 25.20 | | |
| 20 | 100 | 0 | | 25.33 | 25.28 | 25.22 | | |
| 20 | 1 | 0 | 16-QAM | 25.46 | 25.52 | 25.53 | 26.54 | 0.4508 |
| 20 | 1 | 49 | | 25.70 | 25.36 | 25.52 | | |
| 20 | 1 | 99 | | 25.67 | 25.38 | 25.25 | | |
| 20 | 50 | 0 | | 24.33 | 24.26 | 24.16 | | |
| 20 | 50 | 24 | | 24.31 | 24.26 | 24.18 | | |
| 20 | 50 | 50 | | 24.32 | 24.24 | 24.17 | | |
| 20 | 100 | 0 | | 24.32 | 24.32 | 24.21 | | |
| 20 | 1 | 0 | 64-QAM | 24.19 | 24.44 | 24.05 | 25.28 | 0.3373 |
| 20 | 1 | 49 | | 24.33 | 24.22 | 24.16 | | |
| 20 | 1 | 99 | | 24.30 | 24.16 | 24.26 | | |
| 20 | 50 | 0 | | 23.32 | 23.31 | 23.44 | | |
| 20 | 50 | 24 | | 23.45 | 23.29 | 23.19 | | |
| 20 | 50 | 50 | | 23.29 | 23.26 | 23.18 | | |
| 20 | 100 | 0 | | 23.51 | 23.28 | 23.20 | | |
| 20 | 1 | 0 | 256-QAM | 21.27 | 21.74 | 21.17 | 22.58 | 0.1811 |
| 20 | 1 | 49 | | 20.91 | 21.46 | 20.89 | | |
| 20 | 1 | 99 | | 20.84 | 21.41 | 20.74 | | |
| 20 | 50 | 0 | | 18.96 | 19.43 | 18.76 | | |
| 20 | 50 | 24 | | 18.81 | 19.37 | 18.73 | | |
| 20 | 50 | 50 | | 18.79 | 19.30 | 18.70 | | |
| 20 | 100 | 0 | | 18.85 | 19.33 | 18.72 | | |
| Limit | EIRP < 2W | | | Result | | | Pass | |



| LTE Band 41(HPUE) Maximum Average Power [dBm] (GT - LC = 0.84 dB) | | | | | | | | |
|---|-----------|-----------|---------|--------|--------|---------|------------|----------|
| BW [MHz] | RB Size | RB Offset | Mod | Lowest | Middle | Highest | EIRP (dBm) | EIRP (W) |
| 15 | 1 | 0 | QPSK | 26.20 | 26.10 | 26.08 | 27.04 | 0.5058 |
| 15 | 1 | 37 | | 26.17 | 26.18 | 25.99 | | |
| 15 | 1 | 74 | | 26.07 | 26.12 | 26.04 | | |
| 15 | 36 | 0 | | 25.34 | 25.27 | 25.19 | | |
| 15 | 36 | 20 | | 25.21 | 25.15 | 25.16 | | |
| 15 | 36 | 39 | | 25.29 | 25.20 | 25.04 | | |
| 15 | 75 | 0 | | 25.26 | 25.26 | 25.09 | | |
| 15 | 1 | 0 | 16-QAM | 25.45 | 25.46 | 25.35 | 26.52 | 0.4487 |
| 15 | 1 | 37 | | 25.68 | 25.19 | 25.35 | | |
| 15 | 1 | 74 | | 25.53 | 25.33 | 25.11 | | |
| 15 | 36 | 0 | | 24.29 | 24.14 | 24.08 | | |
| 15 | 36 | 20 | | 24.31 | 24.25 | 24.14 | | |
| 15 | 36 | 39 | | 24.13 | 24.23 | 24.01 | | |
| 15 | 75 | 0 | | 24.30 | 24.22 | 24.07 | | |
| 15 | 1 | 0 | 64-QAM | 24.11 | 24.44 | 23.87 | 25.28 | 0.3373 |
| 15 | 1 | 37 | | 24.17 | 24.19 | 24.08 | | |
| 15 | 1 | 74 | | 24.17 | 24.08 | 24.19 | | |
| 15 | 36 | 0 | | 23.20 | 23.21 | 23.40 | | |
| 15 | 36 | 20 | | 23.31 | 23.19 | 23.17 | | |
| 15 | 36 | 39 | | 23.28 | 23.08 | 23.16 | | |
| 15 | 75 | 0 | | 23.36 | 23.24 | 23.17 | | |
| 15 | 1 | 0 | 256-QAM | 21.11 | 21.74 | 21.16 | 22.58 | 0.1811 |
| 15 | 1 | 37 | | 20.90 | 21.28 | 20.69 | | |
| 15 | 1 | 74 | | 20.79 | 21.23 | 20.65 | | |
| 15 | 36 | 0 | | 18.83 | 19.30 | 18.70 | | |
| 15 | 36 | 20 | | 18.79 | 19.26 | 18.66 | | |
| 15 | 36 | 39 | | 18.75 | 19.21 | 18.63 | | |
| 15 | 75 | 0 | | 18.67 | 19.21 | 18.56 | | |
| Limit | EIRP < 2W | | | Result | | | Pass | |



| LTE Band 41(HPUE) Maximum Average Power [dBm] (GT - LC = 0.84 dB) | | | | | | | | |
|---|-----------|-----------|---------|--------|--------|---------|------------|----------|
| BW [MHz] | RB Size | RB Offset | Mod | Lowest | Middle | Highest | EIRP (dBm) | EIRP (W) |
| 10 | 1 | 0 | QPSK | 26.24 | 26.13 | 26.17 | 27.08 | 0.5105 |
| 10 | 1 | 25 | | 26.00 | 26.06 | 25.90 | | |
| 10 | 1 | 49 | | 26.02 | 26.01 | 25.90 | | |
| 10 | 25 | 0 | | 25.24 | 25.31 | 25.13 | | |
| 10 | 25 | 12 | | 25.22 | 25.06 | 25.16 | | |
| 10 | 25 | 25 | | 25.22 | 25.22 | 25.09 | | |
| 10 | 50 | 0 | | 25.24 | 25.23 | 25.13 | | |
| 10 | 1 | 0 | 16-QAM | 25.36 | 25.42 | 25.47 | 26.51 | 0.4477 |
| 10 | 1 | 25 | | 25.63 | 25.36 | 25.41 | | |
| 10 | 1 | 49 | | 25.67 | 25.32 | 25.06 | | |
| 10 | 25 | 0 | | 24.18 | 24.12 | 24.01 | | |
| 10 | 25 | 12 | | 24.14 | 24.20 | 24.11 | | |
| 10 | 25 | 25 | | 24.29 | 24.18 | 24.13 | | |
| 10 | 50 | 0 | | 24.18 | 24.26 | 24.15 | | |
| 10 | 1 | 0 | 64-QAM | 24.02 | 24.36 | 23.96 | 25.20 | 0.3311 |
| 10 | 1 | 25 | | 24.18 | 24.10 | 24.15 | | |
| 10 | 1 | 49 | | 24.13 | 24.13 | 24.21 | | |
| 10 | 25 | 0 | | 23.21 | 23.13 | 23.28 | | |
| 10 | 25 | 12 | | 23.29 | 23.18 | 23.05 | | |
| 10 | 25 | 25 | | 23.23 | 23.20 | 23.12 | | |
| 10 | 50 | 0 | | 23.32 | 23.13 | 23.15 | | |
| 10 | 1 | 0 | 256-QAM | 21.21 | 21.67 | 21.16 | 22.51 | 0.1782 |
| 10 | 1 | 25 | | 20.88 | 21.45 | 20.85 | | |
| 10 | 1 | 49 | | 20.82 | 21.28 | 20.71 | | |
| 10 | 25 | 0 | | 18.77 | 19.29 | 18.62 | | |
| 10 | 25 | 12 | | 18.79 | 19.30 | 18.71 | | |
| 10 | 25 | 25 | | 18.70 | 19.24 | 18.59 | | |
| 10 | 50 | 0 | | 18.76 | 19.20 | 18.62 | | |
| Limit | EIRP < 2W | | | Result | | | Pass | |



| LTE Band 41(HPUE) Maximum Average Power [dBm] (GT - LC = 0.84 dB) | | | | | | | | |
|---|-----------|-----------|---------|--------|--------|---------|------------|----------|
| BW [MHz] | RB Size | RB Offset | Mod | Lowest | Middle | Highest | EIRP (dBm) | EIRP (W) |
| 5 | 1 | 0 | QPSK | 26.25 | 26.12 | 26.13 | 27.09 | 0.5117 |
| 5 | 1 | 12 | | 26.02 | 26.08 | 25.96 | | |
| 5 | 1 | 24 | | 26.03 | 26.07 | 25.88 | | |
| 5 | 12 | 0 | | 25.25 | 25.17 | 25.05 | | |
| 5 | 12 | 7 | | 25.22 | 25.26 | 25.09 | | |
| 5 | 12 | 13 | | 25.22 | 25.18 | 25.20 | | |
| 5 | 25 | 0 | | 25.33 | 25.08 | 25.06 | | |
| 5 | 1 | 0 | 16-QAM | 25.32 | 25.44 | 25.46 | 26.49 | 0.4457 |
| 5 | 1 | 12 | | 25.65 | 25.36 | 25.39 | | |
| 5 | 1 | 24 | | 25.48 | 25.32 | 25.24 | | |
| 5 | 12 | 0 | | 24.30 | 24.11 | 24.04 | | |
| 5 | 12 | 7 | | 24.17 | 24.26 | 23.99 | | |
| 5 | 12 | 13 | | 24.27 | 24.10 | 24.05 | | |
| 5 | 25 | 0 | | 24.25 | 24.29 | 24.05 | | |
| 5 | 1 | 0 | 64-QAM | 24.07 | 24.25 | 24.03 | 25.17 | 0.3289 |
| 5 | 1 | 12 | | 24.33 | 24.21 | 23.97 | | |
| 5 | 1 | 24 | | 24.12 | 24.14 | 24.26 | | |
| 5 | 12 | 0 | | 23.23 | 23.22 | 23.33 | | |
| 5 | 12 | 7 | | 23.40 | 23.21 | 23.03 | | |
| 5 | 12 | 13 | | 23.23 | 23.22 | 23.04 | | |
| 5 | 25 | 0 | | 23.45 | 23.08 | 23.17 | | |
| 5 | 1 | 0 | 256-QAM | 21.13 | 21.56 | 20.99 | 22.40 | 0.1738 |
| 5 | 1 | 12 | | 20.76 | 21.39 | 20.80 | | |
| 5 | 1 | 24 | | 20.66 | 21.27 | 20.72 | | |
| 5 | 12 | 0 | | 18.77 | 19.27 | 18.57 | | |
| 5 | 12 | 7 | | 18.63 | 19.34 | 18.64 | | |
| 5 | 12 | 13 | | 18.65 | 19.26 | 18.69 | | |
| 5 | 25 | 0 | | 18.83 | 19.24 | 18.65 | | |
| Limit | EIRP < 2W | | | Result | | | Pass | |



| LTE Band 30 Maximum Average Power [dBm] (GT - LC = -0.1 dB) | | | | | | | | |
|---|-------------------|-----------|---------|--------|--------|---------|------------|----------|
| BW [MHz] | RB Size | RB Offset | Mod | Lowest | Middle | Highest | EIRP (dBm) | EIRP (W) |
| 10 | 1 | 0 | QPSK | | 22.50 | | 22.40 | 0.1738 |
| 10 | 1 | 25 | | | 22.37 | | | |
| 10 | 1 | 49 | | | 22.36 | | | |
| 10 | 25 | 0 | | | 21.53 | | | |
| 10 | 25 | 12 | | | 21.50 | | | |
| 10 | 25 | 25 | | | 21.48 | | | |
| 10 | 50 | 0 | | | 21.47 | | | |
| 10 | 1 | 0 | 16-QAM | | 21.76 | | 21.66 | 0.1466 |
| 10 | 1 | 25 | | | 21.60 | | | |
| 10 | 1 | 49 | | | 21.64 | | | |
| 10 | 25 | 0 | | | 20.49 | | | |
| 10 | 25 | 12 | | | 20.51 | | | |
| 10 | 25 | 25 | | | 20.48 | | | |
| 10 | 50 | 0 | | | 20.45 | | | |
| 10 | 1 | 0 | 64-QAM | - | 20.61 | - | 20.51 | 0.1125 |
| 10 | 1 | 25 | | | 20.58 | | | |
| 10 | 1 | 49 | | | 20.49 | | | |
| 10 | 25 | 0 | | | 19.46 | | | |
| 10 | 25 | 12 | | | 19.45 | | | |
| 10 | 25 | 25 | | | 19.44 | | | |
| 10 | 50 | 0 | | | 19.44 | | | |
| 10 | 1 | 0 | 256-QAM | | 17.55 | | 17.45 | 0.0556 |
| 10 | 1 | 25 | | | 17.50 | | | |
| 10 | 1 | 49 | | | 17.50 | | | |
| 10 | 25 | 0 | | | 17.49 | | | |
| 10 | 25 | 12 | | | 17.47 | | | |
| 10 | 25 | 25 | | | 17.42 | | | |
| 10 | 50 | 0 | | | 17.44 | | | |
| Limit | EIRP < 250mW/5MHz | | | Result | | | Pass | |

Total EIRP power is less than partial EIRP limit 250 mW/5MHz.



| LTE Band 30 Maximum Average Power [dBm] (GT - LC = -0.1 dB) | | | | | | | | |
|---|-------------------|-----------|---------|--------|--------|---------|------------|----------|
| BW [MHz] | RB Size | RB Offset | Mod | Lowest | Middle | Highest | EIRP (dBm) | EIRP (W) |
| 5 | 1 | 0 | QPSK | 22.34 | 22.44 | 22.46 | 22.36 | 0.1722 |
| 5 | 1 | 12 | | 22.21 | 22.32 | 22.37 | | |
| 5 | 1 | 24 | | 22.22 | 22.17 | 22.36 | | |
| 5 | 12 | 0 | | 21.42 | 21.48 | 21.43 | | |
| 5 | 12 | 7 | | 21.46 | 21.36 | 21.36 | | |
| 5 | 12 | 13 | | 21.44 | 21.33 | 21.28 | | |
| 5 | 25 | 0 | | 21.35 | 21.43 | 21.38 | | |
| 5 | 1 | 0 | 16-QAM | 21.60 | 21.59 | 21.58 | 21.50 | 0.1413 |
| 5 | 1 | 12 | | 21.50 | 21.53 | 21.42 | | |
| 5 | 1 | 24 | | 21.55 | 21.48 | 21.46 | | |
| 5 | 12 | 0 | | 20.30 | 20.30 | 20.29 | | |
| 5 | 12 | 7 | | 20.45 | 20.45 | 20.35 | | |
| 5 | 12 | 13 | | 20.46 | 20.33 | 20.31 | | |
| 5 | 25 | 0 | | 20.39 | 20.34 | 20.35 | | |
| 5 | 1 | 0 | 64-QAM | 20.58 | 20.51 | 20.50 | 20.48 | 0.1117 |
| 5 | 1 | 12 | | 20.55 | 20.46 | 20.55 | | |
| 5 | 1 | 24 | | 20.44 | 20.32 | 20.37 | | |
| 5 | 12 | 0 | | 19.38 | 19.28 | 19.26 | | |
| 5 | 12 | 7 | | 19.30 | 19.39 | 19.40 | | |
| 5 | 12 | 13 | | 19.28 | 19.34 | 19.33 | | |
| 5 | 25 | 0 | | 19.27 | 19.38 | 19.44 | | |
| 5 | 1 | 0 | 256-QAM | 17.48 | 17.38 | 17.38 | 17.38 | 0.0547 |
| 5 | 1 | 12 | | 17.43 | 17.44 | 17.42 | | |
| 5 | 1 | 24 | | 17.48 | 17.42 | 17.35 | | |
| 5 | 12 | 0 | | 17.31 | 17.36 | 17.48 | | |
| 5 | 12 | 7 | | 17.39 | 17.40 | 17.31 | | |
| 5 | 12 | 13 | | 17.27 | 17.38 | 17.39 | | |
| 5 | 25 | 0 | | 17.28 | 17.25 | 17.39 | | |
| Limit | EIRP < 250mW/5MHz | | | Result | | | Pass | |

Total EIRP power is less than partial EIRP limit 250 mW/5MHz.



| LTE Band 66 Maximum Average Power [dBm] (GT - LC = 0.05 dB) | | | | | | | | |
|---|-----------|-----------|---------|--------|--------|---------|------------|----------|
| BW [MHz] | RB Size | RB Offset | Mod | Lowest | Middle | Highest | EIRP (dBm) | EIRP (W) |
| 20 | 1 | 0 | QPSK | 24.79 | 24.83 | 24.66 | 24.88 | 0.3076 |
| 20 | 1 | 49 | | 24.71 | 24.70 | 24.65 | | |
| 20 | 1 | 99 | | 24.77 | 24.45 | 24.30 | | |
| 20 | 50 | 0 | | 23.84 | 23.85 | 23.82 | | |
| 20 | 50 | 24 | | 23.82 | 23.82 | 23.69 | | |
| 20 | 50 | 50 | | 23.80 | 23.78 | 23.54 | | |
| 20 | 100 | 0 | | 23.71 | 23.88 | 23.65 | | |
| 20 | 1 | 0 | 16-QAM | 23.97 | 24.14 | 24.31 | 24.36 | 0.2729 |
| 20 | 1 | 49 | | 24.02 | 23.95 | 23.90 | | |
| 20 | 1 | 99 | | 24.13 | 23.83 | 23.62 | | |
| 20 | 50 | 0 | | 22.81 | 22.83 | 22.79 | | |
| 20 | 50 | 24 | | 22.84 | 22.76 | 22.68 | | |
| 20 | 50 | 50 | | 22.86 | 22.68 | 22.52 | | |
| 20 | 100 | 0 | | 22.83 | 22.70 | 22.64 | | |
| 20 | 1 | 0 | 64-QAM | 22.99 | 23.01 | 23.21 | 23.26 | 0.2118 |
| 20 | 1 | 49 | | 22.96 | 22.80 | 22.79 | | |
| 20 | 1 | 99 | | 23.04 | 22.84 | 22.64 | | |
| 20 | 50 | 0 | | 21.84 | 21.82 | 21.82 | | |
| 20 | 50 | 24 | | 21.86 | 21.77 | 21.69 | | |
| 20 | 50 | 50 | | 21.86 | 21.70 | 21.54 | | |
| 20 | 100 | 0 | | 21.83 | 21.72 | 21.65 | | |
| 20 | 1 | 0 | 256-QAM | 19.82 | 19.66 | 19.85 | 19.90 | 0.0977 |
| 20 | 1 | 49 | | 19.77 | 19.64 | 19.83 | | |
| 20 | 1 | 99 | | 19.84 | 19.71 | 19.83 | | |
| 20 | 50 | 0 | | 19.66 | 19.52 | 19.65 | | |
| 20 | 50 | 24 | | 19.73 | 19.62 | 19.75 | | |
| 20 | 50 | 50 | | 19.74 | 19.61 | 19.79 | | |
| 20 | 100 | 0 | | 19.66 | 19.59 | 19.73 | | |
| Limit | EIRP < 1W | | | Result | | | Pass | |



| LTE Band 66 Maximum Average Power [dBm] (GT - LC = 0.05 dB) | | | | | | | | |
|---|-----------|-----------|---------|--------|--------|---------|------------|----------|
| BW [MHz] | RB Size | RB Offset | Mod | Lowest | Middle | Highest | EIRP (dBm) | EIRP (W) |
| 15 | 1 | 0 | QPSK | 24.60 | 24.67 | 24.46 | 24.72 | 0.2965 |
| 15 | 1 | 37 | | 24.62 | 24.52 | 24.52 | | |
| 15 | 1 | 74 | | 24.61 | 24.44 | 24.10 | | |
| 15 | 36 | 0 | | 23.72 | 23.66 | 23.67 | | |
| 15 | 36 | 20 | | 23.68 | 23.81 | 23.50 | | |
| 15 | 36 | 39 | | 23.65 | 23.65 | 23.39 | | |
| 15 | 75 | 0 | | 23.61 | 23.80 | 23.61 | | |
| 15 | 1 | 0 | 16-QAM | 23.94 | 23.94 | 24.30 | 24.35 | 0.2723 |
| 15 | 1 | 37 | | 23.83 | 23.81 | 23.74 | | |
| 15 | 1 | 74 | | 23.98 | 23.63 | 23.44 | | |
| 15 | 36 | 0 | | 22.62 | 22.77 | 22.59 | | |
| 15 | 36 | 20 | | 22.67 | 22.59 | 22.59 | | |
| 15 | 36 | 39 | | 22.80 | 22.52 | 22.45 | | |
| 15 | 75 | 0 | | 22.73 | 22.64 | 22.59 | | |
| 15 | 1 | 0 | 64-QAM | 22.97 | 22.95 | 23.17 | 23.22 | 0.2099 |
| 15 | 1 | 37 | | 22.76 | 22.68 | 22.61 | | |
| 15 | 1 | 74 | | 22.96 | 22.74 | 22.48 | | |
| 15 | 36 | 0 | | 21.64 | 21.62 | 21.81 | | |
| 15 | 36 | 20 | | 21.81 | 21.70 | 21.54 | | |
| 15 | 36 | 39 | | 21.85 | 21.62 | 21.46 | | |
| 15 | 75 | 0 | | 21.82 | 21.70 | 21.60 | | |
| 15 | 1 | 0 | 256-QAM | 19.74 | 19.48 | 19.85 | 19.90 | 0.0977 |
| 15 | 1 | 37 | | 19.71 | 19.57 | 19.77 | | |
| 15 | 1 | 74 | | 19.70 | 19.71 | 19.67 | | |
| 15 | 36 | 0 | | 19.55 | 19.51 | 19.65 | | |
| 15 | 36 | 20 | | 19.65 | 19.60 | 19.58 | | |
| 15 | 36 | 39 | | 19.70 | 19.57 | 19.72 | | |
| 15 | 75 | 0 | | 19.54 | 19.49 | 19.72 | | |
| Limit | EIRP < 1W | | | Result | | | Pass | |



| LTE Band 66 Maximum Average Power [dBm] (GT - LC = 0.05 dB) | | | | | | | | |
|---|-----------|-----------|---------|--------|--------|---------|------------|----------|
| BW [MHz] | RB Size | RB Offset | Mod | Lowest | Middle | Highest | EIRP (dBm) | EIRP (W) |
| 10 | 1 | 0 | QPSK | 24.59 | 24.76 | 24.57 | 24.81 | 0.3027 |
| 10 | 1 | 25 | | 24.55 | 24.67 | 24.54 | | |
| 10 | 1 | 49 | | 24.58 | 24.30 | 24.22 | | |
| 10 | 25 | 0 | | 23.75 | 23.79 | 23.67 | | |
| 10 | 25 | 12 | | 23.73 | 23.67 | 23.51 | | |
| 10 | 25 | 25 | | 23.72 | 23.72 | 23.40 | | |
| 10 | 50 | 0 | | 23.51 | 23.73 | 23.46 | | |
| 10 | 1 | 0 | 16-QAM | 23.87 | 23.96 | 24.19 | 24.24 | 0.2655 |
| 10 | 1 | 25 | | 23.86 | 23.75 | 23.73 | | |
| 10 | 1 | 49 | | 24.03 | 23.74 | 23.49 | | |
| 10 | 25 | 0 | | 22.64 | 22.80 | 22.71 | | |
| 10 | 25 | 12 | | 22.74 | 22.72 | 22.61 | | |
| 10 | 25 | 25 | | 22.82 | 22.48 | 22.47 | | |
| 10 | 50 | 0 | | 22.77 | 22.67 | 22.60 | | |
| 10 | 1 | 0 | 64-QAM | 22.83 | 22.87 | 23.10 | 23.15 | 0.2065 |
| 10 | 1 | 25 | | 22.78 | 22.66 | 22.79 | | |
| 10 | 1 | 49 | | 22.88 | 22.81 | 22.61 | | |
| 10 | 25 | 0 | | 21.81 | 21.80 | 21.71 | | |
| 10 | 25 | 12 | | 21.77 | 21.64 | 21.62 | | |
| 10 | 25 | 25 | | 21.84 | 21.68 | 21.44 | | |
| 10 | 50 | 0 | | 21.74 | 21.58 | 21.53 | | |
| 10 | 1 | 0 | 256-QAM | 19.82 | 19.53 | 19.69 | 19.87 | 0.0971 |
| 10 | 1 | 25 | | 19.74 | 19.49 | 19.66 | | |
| 10 | 1 | 49 | | 19.64 | 19.60 | 19.79 | | |
| 10 | 25 | 0 | | 19.62 | 19.36 | 19.50 | | |
| 10 | 25 | 12 | | 19.60 | 19.48 | 19.67 | | |
| 10 | 25 | 25 | | 19.70 | 19.51 | 19.75 | | |
| 10 | 50 | 0 | | 19.62 | 19.57 | 19.58 | | |
| Limit | EIRP < 1W | | | Result | | | Pass | |



| LTE Band 66 Maximum Average Power [dBm] (GT - LC = 0.05 dB) | | | | | | | | |
|---|-----------|-----------|---------|--------|--------|---------|------------|----------|
| BW [MHz] | RB Size | RB Offset | Mod | Lowest | Middle | Highest | EIRP (dBm) | EIRP (W) |
| 5 | 1 | 0 | QPSK | 24.59 | 24.76 | 24.51 | 24.81 | 0.3027 |
| 5 | 1 | 12 | | 24.56 | 24.57 | 24.57 | | |
| 5 | 1 | 24 | | 24.71 | 24.41 | 24.30 | | |
| 5 | 12 | 0 | | 23.81 | 23.66 | 23.78 | | |
| 5 | 12 | 7 | | 23.71 | 23.63 | 23.63 | | |
| 5 | 12 | 13 | | 23.78 | 23.76 | 23.45 | | |
| 5 | 25 | 0 | | 23.54 | 23.70 | 23.63 | | |
| 5 | 1 | 0 | 16-QAM | 23.92 | 23.94 | 24.24 | 24.29 | 0.2685 |
| 5 | 1 | 12 | | 24.02 | 23.94 | 23.84 | | |
| 5 | 1 | 24 | | 24.11 | 23.78 | 23.50 | | |
| 5 | 12 | 0 | | 22.70 | 22.71 | 22.73 | | |
| 5 | 12 | 7 | | 22.78 | 22.58 | 22.52 | | |
| 5 | 12 | 13 | | 22.81 | 22.53 | 22.43 | | |
| 5 | 25 | 0 | | 22.74 | 22.66 | 22.45 | | |
| 5 | 1 | 0 | 64-QAM | 22.94 | 22.91 | 23.10 | 23.15 | 0.2065 |
| 5 | 1 | 12 | | 22.76 | 22.74 | 22.72 | | |
| 5 | 1 | 24 | | 22.86 | 22.83 | 22.49 | | |
| 5 | 12 | 0 | | 21.83 | 21.81 | 21.74 | | |
| 5 | 12 | 7 | | 21.69 | 21.67 | 21.50 | | |
| 5 | 12 | 13 | | 21.69 | 21.65 | 21.54 | | |
| 5 | 25 | 0 | | 21.75 | 21.61 | 21.62 | | |
| 5 | 1 | 0 | 256-QAM | 19.72 | 19.66 | 19.68 | 19.84 | 0.0964 |
| 5 | 1 | 12 | | 19.64 | 19.54 | 19.64 | | |
| 5 | 1 | 24 | | 19.77 | 19.66 | 19.66 | | |
| 5 | 12 | 0 | | 19.49 | 19.37 | 19.61 | | |
| 5 | 12 | 7 | | 19.70 | 19.52 | 19.74 | | |
| 5 | 12 | 13 | | 19.72 | 19.55 | 19.79 | | |
| 5 | 25 | 0 | | 19.60 | 19.48 | 19.58 | | |
| Limit | EIRP < 1W | | | Result | | | Pass | |



| LTE Band 66 Maximum Average Power [dBm] (GT - LC = 0.05 dB) | | | | | | | | |
|---|-----------|-----------|---------|--------|--------|---------|------------|----------|
| BW [MHz] | RB Size | RB Offset | Mod | Lowest | Middle | Highest | EIRP (dBm) | EIRP (W) |
| 3 | 1 | 0 | QPSK | 24.70 | 24.74 | 24.61 | 24.79 | 0.3013 |
| 3 | 1 | 8 | | 24.67 | 24.64 | 24.65 | | |
| 3 | 1 | 14 | | 24.68 | 24.30 | 24.10 | | |
| 3 | 8 | 0 | | 23.69 | 23.77 | 23.74 | | |
| 3 | 8 | 4 | | 23.81 | 23.76 | 23.68 | | |
| 3 | 8 | 7 | | 23.78 | 23.78 | 23.50 | | |
| 3 | 15 | 0 | | 23.71 | 23.73 | 23.63 | | |
| 3 | 1 | 0 | 16-QAM | 23.97 | 24.13 | 24.25 | 24.30 | 0.2692 |
| 3 | 1 | 8 | | 23.96 | 23.93 | 23.83 | | |
| 3 | 1 | 14 | | 24.05 | 23.64 | 23.49 | | |
| 3 | 8 | 0 | | 22.72 | 22.65 | 22.70 | | |
| 3 | 8 | 4 | | 22.74 | 22.72 | 22.63 | | |
| 3 | 8 | 7 | | 22.69 | 22.63 | 22.48 | | |
| 3 | 15 | 0 | | 22.74 | 22.68 | 22.56 | | |
| 3 | 1 | 0 | 64-QAM | 22.79 | 22.81 | 23.16 | 23.21 | 0.2094 |
| 3 | 1 | 8 | | 22.92 | 22.78 | 22.69 | | |
| 3 | 1 | 14 | | 22.87 | 22.82 | 22.44 | | |
| 3 | 8 | 0 | | 21.70 | 21.64 | 21.76 | | |
| 3 | 8 | 4 | | 21.69 | 21.75 | 21.63 | | |
| 3 | 8 | 7 | | 21.77 | 21.59 | 21.38 | | |
| 3 | 15 | 0 | | 21.73 | 21.52 | 21.51 | | |
| 3 | 1 | 0 | 256-QAM | 19.77 | 19.62 | 19.69 | 19.82 | 0.0959 |
| 3 | 1 | 8 | | 19.68 | 19.59 | 19.73 | | |
| 3 | 1 | 14 | | 19.73 | 19.66 | 19.71 | | |
| 3 | 8 | 0 | | 19.46 | 19.37 | 19.49 | | |
| 3 | 8 | 4 | | 19.58 | 19.59 | 19.57 | | |
| 3 | 8 | 7 | | 19.67 | 19.42 | 19.70 | | |
| 3 | 15 | 0 | | 19.58 | 19.42 | 19.73 | | |
| Limit | EIRP < 1W | | | Result | | | Pass | |



| LTE Band 66 Maximum Average Power [dBm] (GT - LC = 0.05 dB) | | | | | | | | |
|---|-----------|-----------|---------|--------|--------|---------|------------|----------|
| BW [MHz] | RB Size | RB Offset | Mod | Lowest | Middle | Highest | EIRP (dBm) | EIRP (W) |
| 1.4 | 1 | 0 | QPSK | 24.70 | 24.64 | 24.57 | 24.87 | 0.3069 |
| 1.4 | 1 | 3 | | 24.57 | 24.56 | 24.52 | | |
| 1.4 | 1 | 5 | | 24.57 | 24.42 | 24.19 | | |
| 1.4 | 3 | 0 | | 24.63 | 24.82 | 24.63 | | |
| 1.4 | 3 | 1 | | 24.70 | 24.55 | 24.55 | | |
| 1.4 | 3 | 3 | | 24.59 | 24.28 | 24.11 | | |
| 1.4 | 6 | 0 | | 23.82 | 23.69 | 23.80 | | |
| 1.4 | 1 | 0 | 16-QAM | 23.77 | 23.82 | 23.50 | 24.19 | 0.2624 |
| 1.4 | 1 | 3 | | 23.62 | 23.70 | 23.37 | | |
| 1.4 | 1 | 5 | | 23.69 | 23.70 | 23.53 | | |
| 1.4 | 3 | 0 | | 23.78 | 23.94 | 24.14 | | |
| 1.4 | 3 | 1 | | 24.01 | 23.86 | 23.73 | | |
| 1.4 | 3 | 3 | | 23.95 | 23.73 | 23.51 | | |
| 1.4 | 6 | 0 | | 22.73 | 22.78 | 22.61 | | |
| 1.4 | 1 | 0 | 64-QAM | 22.75 | 22.69 | 22.65 | 23.17 | 0.2075 |
| 1.4 | 1 | 3 | | 22.78 | 22.50 | 22.44 | | |
| 1.4 | 1 | 5 | | 22.64 | 22.69 | 22.46 | | |
| 1.4 | 3 | 0 | | 22.91 | 22.98 | 23.12 | | |
| 1.4 | 3 | 1 | | 22.78 | 22.79 | 22.68 | | |
| 1.4 | 3 | 3 | | 22.95 | 22.68 | 22.51 | | |
| 1.4 | 6 | 0 | | 21.73 | 21.78 | 21.68 | | |
| 1.4 | 1 | 0 | 256-QAM | 19.78 | 19.65 | 19.67 | 19.87 | 0.0971 |
| 1.4 | 1 | 3 | | 19.63 | 19.57 | 19.82 | | |
| 1.4 | 1 | 5 | | 19.76 | 19.55 | 19.68 | | |
| 1.4 | 3 | 0 | | 19.53 | 19.36 | 19.49 | | |
| 1.4 | 3 | 1 | | 19.58 | 19.56 | 19.61 | | |
| 1.4 | 3 | 3 | | 19.58 | 19.43 | 19.73 | | |
| 1.4 | 6 | 0 | | 19.53 | 19.42 | 19.63 | | |
| Limit | EIRP < 1W | | | Result | | | Pass | |



| LTE Band 71 Maximum Average Power [dBm] (GT - LC = -0.04 dB) | | | | | | | | |
|--|----------|-----------|---------|--------|--------|---------|-----------|---------|
| BW [MHz] | RB Size | RB Offset | Mod | Lowest | Middle | Highest | ERP (dBm) | ERP (W) |
| 20 | 1 | 0 | QPSK | 24.68 | 24.67 | 24.63 | 22.49 | 0.1774 |
| 20 | 1 | 49 | | 24.53 | 24.53 | 24.44 | | |
| 20 | 1 | 99 | | 24.50 | 24.46 | 24.44 | | |
| 20 | 50 | 0 | | 23.62 | 23.58 | 23.52 | | |
| 20 | 50 | 24 | | 23.57 | 23.57 | 23.46 | | |
| 20 | 50 | 50 | | 23.51 | 23.51 | 23.44 | | |
| 20 | 100 | 0 | | 23.54 | 23.52 | 23.43 | | |
| 20 | 1 | 0 | 16-QAM | 24.06 | 24.03 | 23.96 | 21.87 | 0.1538 |
| 20 | 1 | 49 | | 24.06 | 23.87 | 23.80 | | |
| 20 | 1 | 99 | | 23.92 | 23.96 | 23.71 | | |
| 20 | 50 | 0 | | 22.61 | 22.62 | 22.55 | | |
| 20 | 50 | 24 | | 22.61 | 22.61 | 22.54 | | |
| 20 | 50 | 50 | | 22.57 | 22.57 | 22.50 | | |
| 20 | 100 | 0 | | 22.56 | 22.54 | 22.47 | | |
| 20 | 1 | 0 | 64-QAM | 22.89 | 22.91 | 22.80 | 20.80 | 0.1202 |
| 20 | 1 | 49 | | 22.99 | 22.80 | 22.68 | | |
| 20 | 1 | 99 | | 22.95 | 22.94 | 22.67 | | |
| 20 | 50 | 0 | | 21.66 | 21.65 | 21.61 | | |
| 20 | 50 | 24 | | 21.65 | 21.63 | 21.59 | | |
| 20 | 50 | 50 | | 21.62 | 21.59 | 21.54 | | |
| 20 | 100 | 0 | | 21.59 | 21.54 | 21.47 | | |
| 20 | 1 | 0 | 256-QAM | 19.85 | 19.88 | 20.01 | 17.82 | 0.0605 |
| 20 | 1 | 49 | | 19.69 | 19.78 | 19.86 | | |
| 20 | 1 | 99 | | 19.46 | 19.52 | 19.58 | | |
| 20 | 50 | 0 | | 19.80 | 19.87 | 19.91 | | |
| 20 | 50 | 24 | | 19.52 | 19.65 | 19.72 | | |
| 20 | 50 | 50 | | 19.46 | 19.49 | 19.60 | | |
| 20 | 100 | 0 | | 19.61 | 19.68 | 19.74 | | |
| Limit | ERP < 3W | | | Result | | | Pass | |



| LTE Band 71 Maximum Average Power [dBm] (GT - LC = -0.04 dB) | | | | | | | | |
|--|----------|-----------|---------|--------|--------|---------|-----------|---------|
| BW [MHz] | RB Size | RB Offset | Mod | Lowest | Middle | Highest | ERP (dBm) | ERP (W) |
| 15 | 1 | 0 | QPSK | 24.52 | 24.49 | 24.56 | 22.37 | 0.1726 |
| 15 | 1 | 37 | | 24.49 | 24.48 | 24.32 | | |
| 15 | 1 | 74 | | 24.40 | 24.39 | 24.28 | | |
| 15 | 36 | 0 | | 23.48 | 23.58 | 23.42 | | |
| 15 | 36 | 20 | | 23.52 | 23.57 | 23.33 | | |
| 15 | 36 | 39 | | 23.36 | 23.49 | 23.37 | | |
| 15 | 75 | 0 | | 23.44 | 23.44 | 23.23 | | |
| 15 | 1 | 0 | 16-QAM | 23.95 | 23.85 | 23.96 | 21.80 | 0.1514 |
| 15 | 1 | 37 | | 23.99 | 23.82 | 23.79 | | |
| 15 | 1 | 74 | | 23.88 | 23.89 | 23.58 | | |
| 15 | 36 | 0 | | 22.52 | 22.55 | 22.46 | | |
| 15 | 36 | 20 | | 22.51 | 22.48 | 22.43 | | |
| 15 | 36 | 39 | | 22.51 | 22.50 | 22.32 | | |
| 15 | 75 | 0 | | 22.36 | 22.41 | 22.36 | | |
| 15 | 1 | 0 | 64-QAM | 22.73 | 22.85 | 22.75 | 20.77 | 0.1194 |
| 15 | 1 | 37 | | 22.96 | 22.63 | 22.65 | | |
| 15 | 1 | 74 | | 22.91 | 22.80 | 22.49 | | |
| 15 | 36 | 0 | | 21.58 | 21.50 | 21.41 | | |
| 15 | 36 | 20 | | 21.47 | 21.53 | 21.54 | | |
| 15 | 36 | 39 | | 21.62 | 21.55 | 21.37 | | |
| 15 | 75 | 0 | | 21.40 | 21.37 | 21.36 | | |
| 15 | 1 | 0 | 256-QAM | 19.84 | 19.72 | 19.81 | 17.65 | 0.0582 |
| 15 | 1 | 37 | | 19.61 | 19.64 | 19.67 | | |
| 15 | 1 | 74 | | 19.42 | 19.36 | 19.52 | | |
| 15 | 36 | 0 | | 19.73 | 19.77 | 19.76 | | |
| 15 | 36 | 20 | | 19.50 | 19.58 | 19.64 | | |
| 15 | 36 | 39 | | 19.37 | 19.35 | 19.54 | | |
| 15 | 75 | 0 | | 19.52 | 19.63 | 19.73 | | |
| Limit | ERP < 3W | | | Result | | | Pass | |



| LTE Band 71 Maximum Average Power [dBm] (GT - LC = -0.04 dB) | | | | | | | | |
|--|----------|-----------|---------|--------|--------|---------|-----------|---------|
| BW [MHz] | RB Size | RB Offset | Mod | Lowest | Middle | Highest | ERP (dBm) | ERP (W) |
| 10 | 1 | 0 | QPSK | 24.50 | 24.55 | 24.56 | 22.37 | 0.1726 |
| 10 | 1 | 25 | | 24.45 | 24.49 | 24.42 | | |
| 10 | 1 | 49 | | 24.37 | 24.32 | 24.31 | | |
| 10 | 25 | 0 | | 23.60 | 23.42 | 23.34 | | |
| 10 | 25 | 12 | | 23.47 | 23.44 | 23.40 | | |
| 10 | 25 | 25 | | 23.32 | 23.51 | 23.26 | | |
| 10 | 50 | 0 | | 23.46 | 23.45 | 23.35 | | |
| 10 | 1 | 0 | 16-QAM | 24.03 | 23.86 | 23.86 | 21.84 | 0.1528 |
| 10 | 1 | 25 | | 23.98 | 23.81 | 23.68 | | |
| 10 | 1 | 49 | | 23.81 | 23.83 | 23.51 | | |
| 10 | 25 | 0 | | 22.53 | 22.50 | 22.44 | | |
| 10 | 25 | 12 | | 22.51 | 22.48 | 22.36 | | |
| 10 | 25 | 25 | | 22.37 | 22.56 | 22.50 | | |
| 10 | 50 | 0 | | 22.50 | 22.38 | 22.42 | | |
| 10 | 1 | 0 | 64-QAM | 22.74 | 22.73 | 22.68 | 20.65 | 0.1161 |
| 10 | 1 | 25 | | 22.84 | 22.79 | 22.63 | | |
| 10 | 1 | 49 | | 22.82 | 22.75 | 22.66 | | |
| 10 | 25 | 0 | | 21.48 | 21.58 | 21.61 | | |
| 10 | 25 | 12 | | 21.53 | 21.59 | 21.51 | | |
| 10 | 25 | 25 | | 21.48 | 21.58 | 21.50 | | |
| 10 | 50 | 0 | | 21.53 | 21.45 | 21.38 | | |
| 10 | 1 | 0 | 256-QAM | 19.73 | 19.74 | 19.91 | 17.72 | 0.0592 |
| 10 | 1 | 25 | | 19.66 | 19.64 | 19.76 | | |
| 10 | 1 | 49 | | 19.32 | 19.44 | 19.52 | | |
| 10 | 25 | 0 | | 19.61 | 19.69 | 19.87 | | |
| 10 | 25 | 12 | | 19.42 | 19.57 | 19.65 | | |
| 10 | 25 | 25 | | 19.40 | 19.43 | 19.47 | | |
| 10 | 50 | 0 | | 19.56 | 19.51 | 19.57 | | |
| Limit | ERP < 3W | | | Result | | | Pass | |



| LTE Band 71 Maximum Average Power [dBm] (GT - LC = -0.04 dB) | | | | | | | | |
|--|----------|-----------|---------|--------|--------|---------|-----------|---------|
| BW [MHz] | RB Size | RB Offset | Mod | Lowest | Middle | Highest | ERP (dBm) | ERP (W) |
| 5 | 1 | 0 | QPSK | 24.61 | 24.61 | 24.61 | 22.42 | 0.1746 |
| 5 | 1 | 12 | | 24.50 | 24.48 | 24.31 | | |
| 5 | 1 | 24 | | 24.49 | 24.38 | 24.41 | | |
| 5 | 12 | 0 | | 23.57 | 23.52 | 23.50 | | |
| 5 | 12 | 7 | | 23.55 | 23.41 | 23.44 | | |
| 5 | 12 | 13 | | 23.45 | 23.35 | 23.39 | | |
| 5 | 25 | 0 | | 23.51 | 23.38 | 23.24 | | |
| 5 | 1 | 0 | 16-QAM | 23.98 | 23.97 | 23.93 | 21.83 | 0.1524 |
| 5 | 1 | 12 | | 24.02 | 23.68 | 23.61 | | |
| 5 | 1 | 24 | | 23.72 | 23.92 | 23.67 | | |
| 5 | 12 | 0 | | 22.50 | 22.49 | 22.51 | | |
| 5 | 12 | 7 | | 22.50 | 22.61 | 22.48 | | |
| 5 | 12 | 13 | | 22.49 | 22.51 | 22.39 | | |
| 5 | 25 | 0 | | 22.54 | 22.46 | 22.27 | | |
| 5 | 1 | 0 | 64-QAM | 22.81 | 22.71 | 22.64 | 20.73 | 0.1183 |
| 5 | 1 | 12 | | 22.86 | 22.66 | 22.57 | | |
| 5 | 1 | 24 | | 22.89 | 22.92 | 22.63 | | |
| 5 | 12 | 0 | | 21.52 | 21.50 | 21.42 | | |
| 5 | 12 | 7 | | 21.48 | 21.56 | 21.49 | | |
| 5 | 12 | 13 | | 21.50 | 21.55 | 21.50 | | |
| 5 | 25 | 0 | | 21.51 | 21.50 | 21.27 | | |
| 5 | 1 | 0 | 256-QAM | 19.75 | 19.80 | 19.97 | 17.78 | 0.0600 |
| 5 | 1 | 12 | | 19.63 | 19.75 | 19.73 | | |
| 5 | 1 | 24 | | 19.33 | 19.37 | 19.47 | | |
| 5 | 12 | 0 | | 19.69 | 19.78 | 19.91 | | |
| 5 | 12 | 7 | | 19.45 | 19.57 | 19.67 | | |
| 5 | 12 | 13 | | 19.30 | 19.46 | 19.44 | | |
| 5 | 25 | 0 | | 19.52 | 19.66 | 19.63 | | |
| Limit | ERP < 3W | | | Result | | | Pass | |



| LTE Band 14 Maximum Average Power [dBm] (GT - LC = -2.49 dB) | | | | | | | | |
|--|----------|-----------|---------|--------|--------|---------|-----------|---------|
| BW [MHz] | RB Size | RB Offset | Mod | Lowest | Middle | Highest | ERP (dBm) | ERP (W) |
| 10 | 1 | 0 | QPSK | | 24.34 | | 19.70 | 0.0933 |
| 10 | 1 | 25 | | | 24.12 | | | |
| 10 | 1 | 49 | | | 24.14 | | | |
| 10 | 25 | 0 | | | 23.28 | | | |
| 10 | 25 | 12 | | | 23.28 | | | |
| 10 | 25 | 25 | | | 23.25 | | | |
| 10 | 50 | 0 | | | 23.28 | | | |
| 10 | 1 | 0 | 16-QAM | | 23.61 | | 18.97 | 0.0789 |
| 10 | 1 | 25 | | | 23.51 | | | |
| 10 | 1 | 49 | | | 23.48 | | | |
| 10 | 25 | 0 | | | 22.30 | | | |
| 10 | 25 | 12 | | | 22.27 | | | |
| 10 | 25 | 25 | | | 22.23 | | | |
| 10 | 50 | 0 | | | 22.26 | | | |
| 10 | 1 | 0 | 64-QAM | | 22.49 | | 17.85 | 0.0610 |
| 10 | 1 | 25 | | | 22.29 | | | |
| 10 | 1 | 49 | | | 22.42 | | | |
| 10 | 25 | 0 | | | 21.27 | | | |
| 10 | 25 | 12 | | | 21.27 | | | |
| 10 | 25 | 25 | | | 21.24 | | | |
| 10 | 50 | 0 | | | 21.26 | | | |
| 10 | 1 | 0 | 256-QAM | | 19.32 | | 14.72 | 0.0296 |
| 10 | 1 | 25 | | | 19.33 | | | |
| 10 | 1 | 49 | | | 19.11 | | | |
| 10 | 25 | 0 | | | 19.36 | | | |
| 10 | 25 | 12 | | | 19.29 | | | |
| 10 | 25 | 25 | | | 19.22 | | | |
| 10 | 50 | 0 | | | 19.23 | | | |
| Limit | ERP < 3W | | | Result | | | Pass | |



| LTE Band 14 Maximum Average Power [dBm] (GT - LC = -2.49 dB) | | | | | | | | |
|--|----------|-----------|---------|--------|--------|---------|-----------|---------|
| BW [MHz] | RB Size | RB Offset | Mod | Lowest | Middle | Highest | ERP (dBm) | ERP (W) |
| 5 | 1 | 0 | QPSK | 24.17 | 24.24 | 24.22 | 19.60 | 0.0912 |
| 5 | 1 | 12 | | 24.09 | 24.12 | 23.98 | | |
| 5 | 1 | 24 | | 23.98 | 24.12 | 24.04 | | |
| 5 | 12 | 0 | | 23.13 | 23.23 | 23.16 | | |
| 5 | 12 | 7 | | 23.19 | 23.28 | 23.12 | | |
| 5 | 12 | 13 | | 23.17 | 23.14 | 23.21 | | |
| 5 | 25 | 0 | | 23.08 | 23.19 | 23.09 | | |
| 5 | 1 | 0 | 16-QAM | 23.48 | 23.41 | 23.56 | 18.92 | 0.0780 |
| 5 | 1 | 12 | | 23.31 | 23.32 | 23.44 | | |
| 5 | 1 | 24 | | 23.34 | 23.40 | 23.44 | | |
| 5 | 12 | 0 | | 22.15 | 22.10 | 22.23 | | |
| 5 | 12 | 7 | | 22.09 | 22.18 | 22.24 | | |
| 5 | 12 | 13 | | 22.05 | 22.13 | 22.21 | | |
| 5 | 25 | 0 | | 22.07 | 22.08 | 22.19 | | |
| 5 | 1 | 0 | 64-QAM | 22.49 | 22.42 | 22.46 | 17.85 | 0.0610 |
| 5 | 1 | 12 | | 22.15 | 22.14 | 22.21 | | |
| 5 | 1 | 24 | | 22.25 | 22.35 | 22.26 | | |
| 5 | 12 | 0 | | 21.13 | 21.20 | 21.09 | | |
| 5 | 12 | 7 | | 21.09 | 21.08 | 21.27 | | |
| 5 | 12 | 13 | | 21.24 | 21.08 | 21.17 | | |
| 5 | 25 | 0 | | 21.13 | 21.22 | 21.09 | | |
| 5 | 1 | 0 | 256-QAM | 19.28 | 19.27 | 19.26 | 14.70 | 0.0295 |
| 5 | 1 | 12 | | 19.21 | 19.31 | 19.19 | | |
| 5 | 1 | 24 | | 19.03 | 19.04 | 18.93 | | |
| 5 | 12 | 0 | | 19.22 | 19.34 | 19.20 | | |
| 5 | 12 | 7 | | 19.22 | 19.20 | 19.29 | | |
| 5 | 12 | 13 | | 19.21 | 19.16 | 19.03 | | |
| 5 | 25 | 0 | | 19.11 | 19.13 | 19.07 | | |
| Limit | ERP < 3W | | | Result | | | Pass | |



| LTE Band 26 (Part90S) Maximum Average Power [dBm] (GT - LC = -1.9 dB) | | | | | | | | |
|---|--------------|-----------|---------|--------|--------|---------|-----------|---------|
| BW [MHz] | RB Size | RB Offset | Mod | Lowest | Middle | Highest | ERP (dBm) | ERP (W) |
| 15 | 1 | 0 | QPSK | 24.36 | - | - | 20.31 | 0.1074 |
| 15 | 1 | 37 | | 24.19 | - | - | | |
| 15 | 1 | 74 | | 24.22 | - | - | | |
| 15 | 36 | 0 | | 23.21 | - | - | | |
| 15 | 36 | 20 | | 23.15 | - | - | | |
| 15 | 36 | 39 | | 23.15 | - | - | | |
| 15 | 75 | 0 | | 23.14 | - | - | | |
| 15 | 1 | 0 | 16-QAM | 23.71 | - | - | 19.66 | 0.0925 |
| 15 | 1 | 37 | | 23.54 | - | - | | |
| 15 | 1 | 74 | | 23.62 | - | - | | |
| 15 | 36 | 0 | | 22.20 | - | - | | |
| 15 | 36 | 20 | | 22.16 | - | - | | |
| 15 | 36 | 39 | | 22.16 | - | - | | |
| 15 | 75 | 0 | | 22.16 | - | - | | |
| 15 | 1 | 0 | 64-QAM | 22.37 | - | - | 18.38 | 0.0689 |
| 15 | 1 | 37 | | 22.41 | - | - | | |
| 15 | 1 | 74 | | 22.43 | - | - | | |
| 15 | 36 | 0 | | 21.25 | - | - | | |
| 15 | 36 | 20 | | 21.19 | - | - | | |
| 15 | 36 | 39 | | 21.17 | - | - | | |
| 15 | 75 | 0 | | 21.16 | - | - | | |
| 15 | 1 | 0 | 256-QAM | 19.49 | - | - | 15.44 | 0.0350 |
| 15 | 1 | 37 | | 19.16 | - | - | | |
| 15 | 1 | 74 | | 19.00 | - | - | | |
| 15 | 36 | 0 | | 19.26 | - | - | | |
| 15 | 36 | 20 | | 19.01 | - | - | | |
| 15 | 36 | 39 | | 18.91 | - | - | | |
| 15 | 75 | 0 | | 19.08 | - | - | | |
| Limit | Power < 100W | | | Result | | | Pass | |



| LTE Band 26 (Part90S) Maximum Average Power [dBm] (GT - LC = -1.9 dB) | | | | | | | | |
|---|--------------|-----------|---------|--------|--------|---------|-----------|---------|
| BW [MHz] | RB Size | RB Offset | Mod | Lowest | Middle | Highest | ERP (dBm) | ERP (W) |
| 10 | 1 | 0 | QPSK | - | 24.08 | - | 20.08 | 0.1019 |
| 10 | 1 | 25 | | - | 24.13 | - | | |
| 10 | 1 | 49 | | - | 24.11 | - | | |
| 10 | 25 | 0 | | - | 23.04 | - | | |
| 10 | 25 | 12 | | - | 23.04 | - | | |
| 10 | 25 | 25 | | - | 23.06 | - | | |
| 10 | 50 | 0 | | - | 23.02 | - | | |
| 10 | 1 | 0 | 16-QAM | - | 23.39 | - | 19.49 | 0.0889 |
| 10 | 1 | 25 | | - | 23.54 | - | | |
| 10 | 1 | 49 | | - | 23.33 | - | | |
| 10 | 25 | 0 | | - | 22.07 | - | | |
| 10 | 25 | 12 | | - | 22.07 | - | | |
| 10 | 25 | 25 | | - | 22.02 | - | | |
| 10 | 50 | 0 | | - | 22.04 | - | | |
| 10 | 1 | 0 | 64-QAM | - | 22.28 | - | 18.29 | 0.0675 |
| 10 | 1 | 25 | | - | 22.30 | - | | |
| 10 | 1 | 49 | | - | 22.34 | - | | |
| 10 | 25 | 0 | | - | 21.19 | - | | |
| 10 | 25 | 12 | | - | 21.20 | - | | |
| 10 | 25 | 25 | | - | 21.06 | - | | |
| 10 | 50 | 0 | | - | 21.00 | - | | |
| 10 | 1 | 0 | 256-QAM | - | 19.36 | - | 15.31 | 0.0340 |
| 10 | 1 | 25 | | - | 19.20 | - | | |
| 10 | 1 | 49 | | - | 19.09 | - | | |
| 10 | 25 | 0 | | - | 19.30 | - | | |
| 10 | 25 | 12 | | - | 18.97 | - | | |
| 10 | 25 | 25 | | - | 18.88 | - | | |
| 10 | 50 | 0 | | - | 19.15 | - | | |
| Limit | Power < 100W | | | Result | | | Pass | |



| LTE Band 26(Part90S) Maximum Average Power [dBm] (GT - LC = -1.9 dB) | | | | | | | | |
|--|--------------|-----------|---------|--------|--------|---------|-----------|---------|
| BW [MHz] | RB Size | RB Offset | Mod | Lowest | Middle | Highest | ERP (dBm) | ERP (W) |
| 5 | 1 | 0 | QPSK | 24.23 | 24.15 | 24.15 | 20.20 | 0.1047 |
| 5 | 1 | 12 | | 24.05 | 24.01 | 24.04 | | |
| 5 | 1 | 24 | | 24.22 | 24.25 | 24.16 | | |
| 5 | 12 | 0 | | 23.14 | 23.18 | 23.20 | | |
| 5 | 12 | 7 | | 23.11 | 23.09 | 23.19 | | |
| 5 | 12 | 13 | | 23.12 | 23.05 | 23.16 | | |
| 5 | 25 | 0 | | 23.06 | 23.15 | 23.08 | | |
| 5 | 1 | 0 | 16-QAM | 23.61 | 23.52 | 23.55 | 19.56 | 0.0904 |
| 5 | 1 | 12 | | 23.44 | 23.46 | 23.44 | | |
| 5 | 1 | 24 | | 23.42 | 23.47 | 23.40 | | |
| 5 | 12 | 0 | | 22.08 | 21.98 | 22.00 | | |
| 5 | 12 | 7 | | 22.09 | 22.01 | 22.07 | | |
| 5 | 12 | 13 | | 22.10 | 22.20 | 22.13 | | |
| 5 | 25 | 0 | | 21.97 | 21.87 | 22.07 | | |
| 5 | 1 | 0 | 64-QAM | 22.24 | 22.31 | 22.31 | 18.32 | 0.0679 |
| 5 | 1 | 12 | | 22.31 | 22.27 | 22.25 | | |
| 5 | 1 | 24 | | 22.31 | 22.30 | 22.37 | | |
| 5 | 12 | 0 | | 21.21 | 21.15 | 21.28 | | |
| 5 | 12 | 7 | | 21.02 | 20.96 | 21.10 | | |
| 5 | 12 | 13 | | 21.09 | 21.07 | 21.15 | | |
| 5 | 25 | 0 | | 21.06 | 21.15 | 20.97 | | |
| 5 | 1 | 0 | 256-QAM | 19.31 | 19.36 | 19.41 | 15.36 | 0.0344 |
| 5 | 1 | 12 | | 19.00 | 19.08 | 18.97 | | |
| 5 | 1 | 24 | | 18.96 | 19.01 | 18.86 | | |
| 5 | 12 | 0 | | 19.26 | 19.27 | 19.36 | | |
| 5 | 12 | 7 | | 18.93 | 18.94 | 18.88 | | |
| 5 | 12 | 13 | | 18.90 | 18.91 | 18.89 | | |
| 5 | 25 | 0 | | 19.03 | 19.05 | 19.01 | | |
| Limit | Power < 100W | | | Result | | | Pass | |



| LTE Band 26(Part90S) Maximum Average Power [dBm] (GT - LC = -1.9 dB) | | | | | | | | |
|--|--------------|-----------|---------|--------|--------|---------|-----------|---------|
| BW [MHz] | RB Size | RB Offset | Mod | Lowest | Middle | Highest | ERP (dBm) | ERP (W) |
| 3 | 1 | 0 | QPSK | 24.33 | 24.32 | 24.33 | 20.28 | 0.1067 |
| 3 | 1 | 8 | | 24.03 | 23.96 | 24.06 | | |
| 3 | 1 | 14 | | 24.12 | 24.06 | 24.05 | | |
| 3 | 8 | 0 | | 23.02 | 23.01 | 23.08 | | |
| 3 | 8 | 4 | | 23.10 | 23.11 | 23.09 | | |
| 3 | 8 | 7 | | 22.98 | 22.96 | 23.08 | | |
| 3 | 15 | 0 | | 23.04 | 23.13 | 22.96 | | |
| 3 | 1 | 0 | 16-QAM | 23.57 | 23.57 | 23.58 | 19.57 | 0.0906 |
| 3 | 1 | 8 | | 23.47 | 23.56 | 23.41 | | |
| 3 | 1 | 14 | | 23.54 | 23.54 | 23.62 | | |
| 3 | 8 | 0 | | 22.04 | 22.00 | 22.02 | | |
| 3 | 8 | 4 | | 22.12 | 22.12 | 22.07 | | |
| 3 | 8 | 7 | | 22.13 | 22.06 | 22.19 | | |
| 3 | 15 | 0 | | 22.16 | 22.12 | 22.24 | | |
| 3 | 1 | 0 | 64-QAM | 22.31 | 22.39 | 22.34 | 18.34 | 0.0682 |
| 3 | 1 | 8 | | 22.26 | 22.19 | 22.21 | | |
| 3 | 1 | 14 | | 22.23 | 22.13 | 22.31 | | |
| 3 | 8 | 0 | | 21.07 | 21.17 | 21.02 | | |
| 3 | 8 | 4 | | 21.05 | 21.06 | 20.98 | | |
| 3 | 8 | 7 | | 21.14 | 21.16 | 21.23 | | |
| 3 | 15 | 0 | | 21.09 | 21.18 | 21.06 | | |
| 3 | 1 | 0 | 256-QAM | 19.34 | 19.26 | 19.34 | 15.29 | 0.0338 |
| 3 | 1 | 8 | | 19.06 | 19.16 | 18.98 | | |
| 3 | 1 | 14 | | 18.89 | 18.87 | 18.92 | | |
| 3 | 8 | 0 | | 19.06 | 19.15 | 19.03 | | |
| 3 | 8 | 4 | | 18.98 | 19.02 | 19.06 | | |
| 3 | 8 | 7 | | 18.87 | 18.84 | 18.91 | | |
| 3 | 15 | 0 | | 18.95 | 19.00 | 18.86 | | |
| Limit | Power < 100W | | | Result | | | Pass | |



| LTE Band 26(Part90S) Maximum Average Power [dBm] (GT - LC = -1.9 dB) | | | | | | | | |
|--|--------------|-----------|---------|--------|--------|---------|-----------|---------|
| BW [MHz] | RB Size | RB Offset | Mod | Lowest | Middle | Highest | ERP (dBm) | ERP (W) |
| 1.4 | 1 | 0 | QPSK | 24.18 | 24.18 | 24.08 | 20.28 | 0.1067 |
| 1.4 | 1 | 3 | | 24.02 | 24.01 | 24.06 | | |
| 1.4 | 1 | 5 | | 24.15 | 24.06 | 24.05 | | |
| 1.4 | 3 | 0 | | 24.26 | 24.33 | 24.30 | | |
| 1.4 | 3 | 1 | | 24.16 | 24.08 | 24.12 | | |
| 1.4 | 3 | 3 | | 24.08 | 23.98 | 23.99 | | |
| 1.4 | 6 | 0 | | 23.20 | 23.25 | 23.23 | | |
| 1.4 | 1 | 0 | 16-QAM | 23.04 | 23.01 | 23.13 | 19.65 | 0.0923 |
| 1.4 | 1 | 3 | | 23.04 | 22.94 | 22.95 | | |
| 1.4 | 1 | 5 | | 23.06 | 22.99 | 23.02 | | |
| 1.4 | 3 | 0 | | 23.70 | 23.65 | 23.62 | | |
| 1.4 | 3 | 1 | | 23.34 | 23.42 | 23.41 | | |
| 1.4 | 3 | 3 | | 23.48 | 23.39 | 23.54 | | |
| 1.4 | 6 | 0 | | 22.01 | 21.94 | 22.03 | | |
| 1.4 | 1 | 0 | 64-QAM | 22.07 | 22.06 | 22.14 | 18.29 | 0.0675 |
| 1.4 | 1 | 3 | | 22.03 | 21.93 | 21.96 | | |
| 1.4 | 1 | 5 | | 22.05 | 22.10 | 22.05 | | |
| 1.4 | 3 | 0 | | 22.26 | 22.31 | 22.17 | | |
| 1.4 | 3 | 1 | | 22.25 | 22.24 | 22.26 | | |
| 1.4 | 3 | 3 | | 22.26 | 22.34 | 22.24 | | |
| 1.4 | 6 | 0 | | 21.21 | 21.13 | 21.31 | | |
| 1.4 | 1 | 0 | 256-QAM | 19.35 | 19.38 | 19.36 | 15.33 | 0.0341 |
| 1.4 | 1 | 3 | | 18.96 | 18.92 | 18.92 | | |
| 1.4 | 1 | 5 | | 18.90 | 18.84 | 19.00 | | |
| 1.4 | 3 | 0 | | 19.06 | 18.99 | 19.00 | | |
| 1.4 | 3 | 1 | | 18.98 | 19.08 | 19.01 | | |
| 1.4 | 3 | 3 | | 18.90 | 18.85 | 18.98 | | |
| 1.4 | 6 | 0 | | 19.00 | 19.04 | 18.94 | | |
| Limit | Power < 100W | | | Result | | | Pass | |



| LTE Band 26(Part90S) Straddle Maximum Average Power [dBm] (GT - LC = -1.9 dB) | | | | | | | | |
|---|----------------|-----------|---------|--------|--------|---------|-----------|---------|
| BW [MHz] | RB Size | RB Offset | Mod | Lowest | Middle | Highest | ERP (dBm) | ERP (W) |
| 15 | 1 | 0 | QPSK | - | 24.36 | - | 20.31 | 0.1074 |
| 15 | 1 | 37 | | - | 24.18 | - | | |
| 15 | 1 | 74 | | - | 24.17 | - | | |
| 15 | 36 | 0 | | - | 23.15 | - | | |
| 15 | 36 | 20 | | - | 23.18 | - | | |
| 15 | 36 | 39 | | - | 23.11 | - | | |
| 15 | 75 | 0 | | - | 23.20 | - | | |
| 15 | 1 | 0 | 16-QAM | - | 23.71 | - | 19.66 | 0.0925 |
| 15 | 1 | 37 | | - | 23.61 | - | | |
| 15 | 1 | 74 | | - | 23.53 | - | | |
| 15 | 36 | 0 | | - | 22.10 | - | | |
| 15 | 36 | 20 | | - | 22.11 | - | | |
| 15 | 36 | 39 | | - | 22.07 | - | | |
| 15 | 75 | 0 | | - | 22.14 | - | | |
| 15 | 1 | 0 | 64-QAM | - | 22.45 | - | 18.46 | 0.0701 |
| 15 | 1 | 37 | | - | 22.51 | - | | |
| 15 | 1 | 74 | | - | 22.44 | - | | |
| 15 | 36 | 0 | | - | 21.18 | - | | |
| 15 | 36 | 20 | | - | 21.13 | - | | |
| 15 | 36 | 39 | | - | 21.22 | - | | |
| 15 | 75 | 0 | | - | 21.23 | - | | |
| 15 | 1 | 0 | 256-QAM | - | 19.53 | - | 15.48 | 0.0353 |
| 15 | 1 | 37 | | - | 19.26 | - | | |
| 15 | 1 | 74 | | - | 18.92 | - | | |
| 15 | 36 | 0 | | - | 19.20 | - | | |
| 15 | 36 | 20 | | - | 18.95 | - | | |
| 15 | 36 | 39 | | - | 18.85 | - | | |
| 15 | 75 | 0 | | - | 19.13 | - | | |
| Limit | Reporting only | | | Result | | | N/A | |



| LTE Band 26(Part90S) Straddle Maximum Average Power [dBm] (GT - LC = -1.9 dB) | | | | | | | | |
|---|----------------|-----------|---------|--------|--------|---------|-----------|---------|
| BW [MHz] | RB Size | RB Offset | Mod | Lowest | Middle | Highest | ERP (dBm) | ERP (W) |
| 10 | 1 | 0 | QPSK | - | 24.11 | - | 20.16 | 0.1038 |
| 10 | 1 | 25 | | - | 24.21 | - | | |
| 10 | 1 | 49 | | - | 24.12 | - | | |
| 10 | 25 | 0 | | - | 23.07 | - | | |
| 10 | 25 | 12 | | - | 23.09 | - | | |
| 10 | 25 | 25 | | - | 23.05 | - | | |
| 10 | 50 | 0 | | - | 23.02 | - | | |
| 10 | 1 | 0 | 16-QAM | - | 23.63 | - | 19.58 | 0.0908 |
| 10 | 1 | 25 | | - | 23.62 | - | | |
| 10 | 1 | 49 | | - | 23.60 | - | | |
| 10 | 25 | 0 | | - | 22.15 | - | | |
| 10 | 25 | 12 | | - | 22.16 | - | | |
| 10 | 25 | 25 | | - | 22.02 | - | | |
| 10 | 50 | 0 | | - | 22.08 | - | | |
| 10 | 1 | 0 | 64-QAM | - | 22.11 | - | 18.27 | 0.0671 |
| 10 | 1 | 25 | | - | 22.21 | - | | |
| 10 | 1 | 49 | | - | 22.32 | - | | |
| 10 | 25 | 0 | | - | 21.15 | - | | |
| 10 | 25 | 12 | | - | 21.09 | - | | |
| 10 | 25 | 25 | | - | 21.03 | - | | |
| 10 | 50 | 0 | | - | 21.13 | - | | |
| 10 | 1 | 0 | 256-QAM | - | 19.39 | - | 15.34 | 0.0342 |
| 10 | 1 | 25 | | - | 19.06 | - | | |
| 10 | 1 | 49 | | - | 18.95 | - | | |
| 10 | 25 | 0 | | - | 19.14 | - | | |
| 10 | 25 | 12 | | - | 18.84 | - | | |
| 10 | 25 | 25 | | - | 18.70 | - | | |
| 10 | 50 | 0 | | - | 18.79 | - | | |
| Limit | Reporting only | | | Result | | | N/A | |



| LTE Band 26(Part90S) Straddle Maximum Average Power [dBm] (GT - LC = -1.9 dB) | | | | | | | | |
|---|----------------|-----------|---------|--------|--------|---------|-----------|---------|
| BW [MHz] | RB Size | RB Offset | Mod | Lowest | Middle | Highest | ERP (dBm) | ERP (W) |
| 5 | 1 | 0 | QPSK | - | 24.29 | - | 20.24 | 0.1057 |
| 5 | 1 | 12 | | - | 24.00 | - | | |
| 5 | 1 | 24 | | - | 24.16 | - | | |
| 5 | 12 | 0 | | - | 23.20 | - | | |
| 5 | 12 | 7 | | - | 23.01 | - | | |
| 5 | 12 | 13 | | - | 23.20 | - | | |
| 5 | 25 | 0 | | - | 23.04 | - | | |
| 5 | 1 | 0 | 16-QAM | - | 23.52 | - | 19.47 | 0.0885 |
| 5 | 1 | 12 | | - | 23.41 | - | | |
| 5 | 1 | 24 | | - | 23.36 | - | | |
| 5 | 12 | 0 | | - | 22.08 | - | | |
| 5 | 12 | 7 | | - | 21.99 | - | | |
| 5 | 12 | 13 | | - | 22.16 | - | | |
| 5 | 25 | 0 | | - | 21.98 | - | | |
| 5 | 1 | 0 | 64-QAM | - | 22.14 | - | 18.33 | 0.0681 |
| 5 | 1 | 12 | | - | 22.38 | - | | |
| 5 | 1 | 24 | | - | 22.34 | - | | |
| 5 | 12 | 0 | | - | 21.30 | - | | |
| 5 | 12 | 7 | | - | 21.02 | - | | |
| 5 | 12 | 13 | | - | 21.10 | - | | |
| 5 | 25 | 0 | | - | 21.16 | - | | |
| 5 | 1 | 0 | 256-QAM | - | 19.30 | - | 15.25 | 0.0335 |
| 5 | 1 | 12 | | - | 19.01 | - | | |
| 5 | 1 | 24 | | - | 18.98 | - | | |
| 5 | 12 | 0 | | - | 19.18 | - | | |
| 5 | 12 | 7 | | - | 18.87 | - | | |
| 5 | 12 | 13 | | - | 18.87 | - | | |
| 5 | 25 | 0 | | - | 18.93 | - | | |
| Limit | Reporting only | | | Result | | | N/A | |



| LTE Band 26(Part90S) Straddle Maximum Average Power [dBm] (GT - LC = -1.9 dB) | | | | | | | | |
|---|----------------|-----------|---------|--------|--------|---------|-----------|---------|
| BW [MHz] | RB Size | RB Offset | Mod | Lowest | Middle | Highest | ERP (dBm) | ERP (W) |
| 3 | 1 | 0 | QPSK | - | 24.25 | - | 20.20 | 0.1047 |
| 3 | 1 | 8 | | - | 24.12 | - | | |
| 3 | 1 | 14 | | - | 24.15 | - | | |
| 3 | 8 | 0 | | - | 22.96 | - | | |
| 3 | 8 | 4 | | - | 23.07 | - | | |
| 3 | 8 | 7 | | - | 22.95 | - | | |
| 3 | 15 | 0 | | - | 23.00 | - | | |
| 3 | 1 | 0 | 16-QAM | - | 23.61 | - | 19.56 | 0.0904 |
| 3 | 1 | 8 | | - | 23.55 | - | | |
| 3 | 1 | 14 | | - | 23.57 | - | | |
| 3 | 8 | 0 | | - | 21.99 | - | | |
| 3 | 8 | 4 | | - | 22.04 | - | | |
| 3 | 8 | 7 | | - | 22.06 | - | | |
| 3 | 15 | 0 | | - | 22.25 | - | | |
| 3 | 1 | 0 | 64-QAM | - | 22.27 | - | 18.22 | 0.0664 |
| 3 | 1 | 8 | | - | 22.21 | - | | |
| 3 | 1 | 14 | | - | 22.20 | - | | |
| 3 | 8 | 0 | | - | 21.00 | - | | |
| 3 | 8 | 4 | | - | 21.04 | - | | |
| 3 | 8 | 7 | | - | 21.23 | - | | |
| 3 | 15 | 0 | | - | 21.07 | - | | |
| 3 | 1 | 0 | 256-QAM | - | 19.38 | - | 15.33 | 0.0341 |
| 3 | 1 | 8 | | - | 19.15 | - | | |
| 3 | 1 | 14 | | - | 18.96 | - | | |
| 3 | 8 | 0 | | - | 19.02 | - | | |
| 3 | 8 | 4 | | - | 19.04 | - | | |
| 3 | 8 | 7 | | - | 18.96 | - | | |
| 3 | 15 | 0 | | - | 18.99 | - | | |
| Limit | Reporting only | | | Result | | | N/A | |



| LTE Band 26(Part90S) Straddle Maximum Average Power [dBm] (GT - LC = -1.9 dB) | | | | | | | | |
|---|----------------|-----------|---------|--------|--------|---------|-----------|---------|
| BW [MHz] | RB Size | RB Offset | Mod | Lowest | Middle | Highest | ERP (dBm) | ERP (W) |
| 1.4 | 1 | 0 | QPSK | - | 24.13 | - | 20.12 | 0.1028 |
| 1.4 | 1 | 3 | | - | 23.92 | - | | |
| 1.4 | 1 | 5 | | - | 24.15 | - | | |
| 1.4 | 3 | 0 | | - | 24.17 | - | | |
| 1.4 | 3 | 1 | | - | 24.07 | - | | |
| 1.4 | 3 | 3 | | - | 24.03 | - | | |
| 1.4 | 6 | 0 | | - | 23.15 | - | | |
| 1.4 | 1 | 0 | 16-QAM | - | 22.98 | - | 19.72 | 0.0938 |
| 1.4 | 1 | 3 | | - | 23.06 | - | | |
| 1.4 | 1 | 5 | | - | 23.04 | - | | |
| 1.4 | 3 | 0 | | - | 23.77 | - | | |
| 1.4 | 3 | 1 | | - | 23.27 | - | | |
| 1.4 | 3 | 3 | | - | 23.49 | - | | |
| 1.4 | 6 | 0 | | - | 21.98 | - | | |
| 1.4 | 1 | 0 | 64-QAM | - | 22.06 | - | 18.28 | 0.0673 |
| 1.4 | 1 | 3 | | - | 22.04 | - | | |
| 1.4 | 1 | 5 | | - | 22.06 | - | | |
| 1.4 | 3 | 0 | | - | 22.21 | - | | |
| 1.4 | 3 | 1 | | - | 22.15 | - | | |
| 1.4 | 3 | 3 | | - | 22.33 | - | | |
| 1.4 | 6 | 0 | | - | 21.25 | - | | |
| 1.4 | 1 | 0 | 256-QAM | - | 19.45 | - | 15.40 | 0.0347 |
| 1.4 | 1 | 3 | | - | 18.89 | - | | |
| 1.4 | 1 | 5 | | - | 18.87 | - | | |
| 1.4 | 3 | 0 | | - | 19.14 | - | | |
| 1.4 | 3 | 1 | | - | 18.93 | - | | |
| 1.4 | 3 | 3 | | - | 18.95 | - | | |
| 1.4 | 6 | 0 | | - | 18.93 | - | | |
| Limit | Reporting only | | | Result | | | N/A | |



| LTE Band 5B_CA Maximum Average Power [dBm] (GT - LC = -1.9 dB) | | | | | | | | | | |
|--|----------|-----------|---------|-----------|---------|--------|--------|---------|-----------|---------|
| BW [MHz] | PCC | | SCC | | Mod | Lowest | Middle | Highest | ERP (dBm) | ERP (W) |
| | RB Size | RB Offset | RB Size | RB Offset | | | | | | |
| 10+10 | 50 | 0 | 50 | 0 | QPSK | 20.35 | 20.34 | 20.41 | 18.09 | 0.0644 |
| 10+10 | 1 | 0 | 1 | 49 | | 15.05 | 15.12 | 15.06 | | |
| 10+10 | 1 | 49 | 1 | 0 | | 22.14 | 21.97 | 22.11 | | |
| 10+10 | 50 | 0 | 50 | 0 | 16-QAM | 19.39 | 19.30 | 19.32 | 17.62 | 0.0578 |
| 10+10 | 1 | 0 | 1 | 49 | | 15.64 | 15.53 | 15.68 | | |
| 10+10 | 1 | 49 | 1 | 0 | | 21.57 | 21.39 | 21.67 | | |
| 10+10 | 50 | 0 | 50 | 0 | 64-QAM | 19.38 | 19.34 | 19.33 | 15.53 | 0.0357 |
| 10+10 | 1 | 0 | 1 | 49 | | 15.63 | 15.46 | 15.52 | | |
| 10+10 | 1 | 49 | 1 | 0 | | 19.57 | 19.45 | 19.58 | | |
| 10+10 | 50 | 0 | 50 | 0 | 256-QAM | 17.43 | 17.18 | 17.12 | 13.42 | 0.0220 |
| 10+10 | 1 | 0 | 1 | 49 | | 15.51 | 15.46 | 15.34 | | |
| 10+10 | 1 | 49 | 1 | 0 | | 17.47 | 17.46 | 17.35 | | |
| 10+5 | 50 | 0 | 25 | 0 | QPSK | 20.43 | 20.19 | 20.61 | 18.13 | 0.0650 |
| 10+5 | 1 | 0 | 1 | 24 | | 13.51 | 12.93 | 13.27 | | |
| 10+5 | 1 | 49 | 1 | 0 | | 21.99 | 21.95 | 22.18 | | |
| 10+5 | 50 | 0 | 25 | 0 | 16-QAM | 19.46 | 19.23 | 19.60 | 17.69 | 0.0587 |
| 10+5 | 1 | 0 | 1 | 24 | | 14.29 | 13.60 | 13.91 | | |
| 10+5 | 1 | 49 | 1 | 0 | | 21.73 | 21.68 | 21.74 | | |
| 10+5 | 50 | 0 | 25 | 0 | 64-QAM | 19.45 | 19.24 | 19.59 | 15.60 | 0.0363 |
| 10+5 | 1 | 0 | 1 | 24 | | 14.12 | 13.38 | 13.77 | | |
| 10+5 | 1 | 49 | 1 | 0 | | 19.56 | 19.53 | 19.65 | | |
| 10+5 | 50 | 0 | 25 | 0 | 256-QAM | 17.62 | 16.97 | 17.43 | 15.27 | 0.0337 |
| 10+5 | 1 | 0 | 1 | 24 | | 19.32 | 13.10 | 13.60 | | |
| 10+5 | 1 | 49 | 1 | 0 | | 17.33 | 17.27 | 17.43 | | |
| 5+10 | 25 | 0 | 50 | 0 | QPSK | 20.58 | 20.24 | 20.41 | 18.16 | 0.0655 |
| 5+10 | 1 | 0 | 1 | 49 | | 13.48 | 12.81 | 13.13 | | |
| 5+10 | 1 | 24 | 1 | 0 | | 22.21 | 22.07 | 22.14 | | |
| 5+10 | 25 | 0 | 50 | 0 | 16-QAM | 19.51 | 19.28 | 19.41 | 17.69 | 0.0587 |
| 5+10 | 1 | 0 | 1 | 49 | | 14.12 | 13.13 | 13.68 | | |
| 5+10 | 1 | 24 | 1 | 0 | | 21.65 | 21.47 | 21.74 | | |
| 5+10 | 25 | 0 | 50 | 0 | 64-QAM | 19.51 | 19.28 | 19.36 | 15.47 | 0.0352 |
| 5+10 | 1 | 0 | 1 | 49 | | 13.95 | 13.19 | 13.51 | | |
| 5+10 | 1 | 24 | 1 | 0 | | 19.52 | 19.40 | 19.39 | | |
| 5+10 | 25 | 0 | 50 | 0 | 256-QAM | 17.71 | 17.18 | 17.13 | 13.66 | 0.0232 |
| 5+10 | 1 | 0 | 1 | 49 | | 13.83 | 12.60 | 13.39 | | |
| 5+10 | 1 | 24 | 1 | 0 | | 17.44 | 17.45 | 17.46 | | |
| Limit | ERP < 7W | | | | | Result | | | Pass | |



| LTE Band 5B_CA Maximum Average Power [dBm] (GT - LC = -1.9 dB) | | | | | | | | | | |
|--|----------|-----------|---------|-----------|---------|--------|--------|---------|-----------|---------|
| BW [MHz] | PCC | | SCC | | Mod | Lowest | Middle | Highest | ERP (dBm) | ERP (W) |
| | RB Size | RB Offset | RB Size | RB Offset | | | | | | |
| 5+3 | 25 | 0 | 15 | 0 | QPSK | 22.53 | 22.21 | 22.60 | 18.55 | 0.0716 |
| 5+3 | 1 | 0 | 1 | 14 | | 14.15 | 13.24 | 14.16 | | |
| 5+3 | 1 | 24 | 1 | 0 | | 22.34 | 22.05 | 22.20 | | |
| 5+3 | 25 | 0 | 15 | 0 | 16-QAM | 22.50 | 22.32 | 22.59 | 18.74 | 0.0748 |
| 5+3 | 1 | 0 | 1 | 14 | | 14.95 | 13.68 | 14.82 | | |
| 5+3 | 1 | 24 | 1 | 0 | | 22.79 | 22.35 | 22.75 | | |
| 5+3 | 25 | 0 | 15 | 0 | 64-QAM | 22.50 | 22.38 | 22.53 | 18.64 | 0.0731 |
| 5+3 | 1 | 0 | 1 | 14 | | 14.73 | 13.76 | 14.67 | | |
| 5+3 | 1 | 24 | 1 | 0 | | 22.69 | 22.05 | 22.51 | | |
| 5+3 | 25 | 0 | 15 | 0 | 256-QAM | 22.66 | 22.13 | 22.68 | 18.63 | 0.0729 |
| 5+3 | 1 | 0 | 1 | 14 | | 14.60 | 18.60 | 14.56 | | |
| 5+3 | 1 | 24 | 1 | 0 | | 22.42 | 22.41 | 22.38 | | |
| 3+5 | 15 | 0 | 25 | 0 | QPSK | 22.54 | 22.16 | 22.48 | 19.79 | 0.0953 |
| 3+5 | 1 | 0 | 1 | 24 | | 14.85 | 14.23 | 14.25 | | |
| 3+5 | 1 | 14 | 1 | 0 | | 23.84 | 21.93 | 22.26 | | |
| 3+5 | 15 | 0 | 25 | 0 | 16-QAM | 22.53 | 22.27 | 22.44 | 18.49 | 0.0706 |
| 3+5 | 1 | 0 | 1 | 24 | | 14.86 | 13.84 | 14.77 | | |
| 3+5 | 1 | 14 | 1 | 0 | | 22.54 | 22.29 | 22.48 | | |
| 3+5 | 15 | 0 | 25 | 0 | 64-QAM | 22.52 | 22.30 | 22.45 | 18.47 | 0.0703 |
| 3+5 | 1 | 0 | 1 | 24 | | 14.60 | 13.66 | 14.38 | | |
| 3+5 | 1 | 14 | 1 | 0 | | 22.48 | 22.28 | 22.49 | | |
| 3+5 | 15 | 0 | 25 | 0 | 256-QAM | 22.63 | 22.04 | 22.64 | 18.59 | 0.0723 |
| 3+5 | 1 | 0 | 1 | 24 | | 14.47 | 13.52 | 14.26 | | |
| 3+5 | 1 | 14 | 1 | 0 | | 22.37 | 22.43 | 22.37 | | |
| Limit | ERP < 7W | | | | | Result | | | Pass | |



| LTE Band 66B_CA Maximum Average Power [dBm] (GT - LC = 0.05 dB) | | | | | | | | | | |
|---|-----------|-----------|---------|-----------|---------|--------|--------|---------|------------|----------|
| BW [MHz] | PCC | | SCC | | Mod | Lowest | Middle | Highest | EIRP (dBm) | EIRP (W) |
| | RB Size | RB Offset | RB Size | RB Offset | | | | | | |
| 10+10 | 50 | 0 | 50 | 0 | QPSK | 20.94 | 20.46 | 20.67 | 22.87 | 0.1936 |
| 10+10 | 1 | 0 | 1 | 49 | | 15.18 | 14.95 | 14.94 | | |
| 10+10 | 1 | 49 | 1 | 0 | | 22.82 | 22.47 | 22.35 | | |
| 10+10 | 50 | 0 | 50 | 0 | 16-QAM | 19.93 | 19.47 | 19.50 | 22.34 | 0.1714 |
| 10+10 | 1 | 0 | 1 | 49 | | 15.54 | 15.45 | 15.44 | | |
| 10+10 | 1 | 49 | 1 | 0 | | 22.29 | 21.99 | 21.63 | | |
| 10+10 | 50 | 0 | 50 | 0 | 64-QAM | 19.95 | 19.41 | 19.54 | 20.20 | 0.1047 |
| 10+10 | 1 | 0 | 1 | 49 | | 15.50 | 15.32 | 15.48 | | |
| 10+10 | 1 | 49 | 1 | 0 | | 20.15 | 19.79 | 19.67 | | |
| 10+10 | 50 | 0 | 50 | 0 | 256-QAM | 17.88 | 17.35 | 17.49 | 18.04 | 0.0637 |
| 10+10 | 1 | 0 | 1 | 49 | | 15.60 | 15.32 | 15.34 | | |
| 10+10 | 1 | 49 | 1 | 0 | | 17.99 | 17.85 | 17.67 | | |
| 15+5 | 75 | 0 | 25 | 0 | QPSK | 20.88 | 20.34 | 20.53 | 22.65 | 0.1841 |
| 15+5 | 1 | 0 | 1 | 24 | | 15.23 | 14.36 | 15.17 | | |
| 15+5 | 1 | 74 | 1 | 0 | | 22.60 | 22.53 | 22.28 | | |
| 15+5 | 75 | 0 | 25 | 0 | 16-QAM | 19.93 | 19.33 | 19.57 | 22.31 | 0.1702 |
| 15+5 | 1 | 0 | 1 | 24 | | 15.71 | 15.39 | 15.38 | | |
| 15+5 | 1 | 74 | 1 | 0 | | 22.26 | 21.59 | 21.45 | | |
| 15+5 | 75 | 0 | 25 | 0 | 64-QAM | 19.85 | 19.35 | 19.56 | 20.07 | 0.1016 |
| 15+5 | 1 | 0 | 1 | 24 | | 15.50 | 15.35 | 15.58 | | |
| 15+5 | 1 | 74 | 1 | 0 | | 20.02 | 20.01 | 19.53 | | |
| 15+5 | 75 | 0 | 25 | 0 | 256-QAM | 17.91 | 17.30 | 17.44 | 18.04 | 0.0637 |
| 15+5 | 1 | 0 | 1 | 24 | | 15.61 | 15.63 | 15.42 | | |
| 15+5 | 1 | 74 | 1 | 0 | | 17.99 | 17.82 | 17.59 | | |
| 5+15 | 25 | 0 | 75 | 0 | QPSK | 20.86 | 20.31 | 20.45 | 22.82 | 0.1914 |
| 5+15 | 1 | 0 | 1 | 74 | | 15.34 | 14.91 | 14.99 | | |
| 5+15 | 1 | 24 | 1 | 0 | | 22.72 | 22.77 | 22.34 | | |
| 5+15 | 25 | 0 | 75 | 0 | 16-QAM | 19.84 | 19.36 | 19.49 | 22.17 | 0.1648 |
| 5+15 | 1 | 0 | 1 | 74 | | 15.62 | 15.44 | 15.45 | | |
| 5+15 | 1 | 24 | 1 | 0 | | 22.12 | 22.02 | 21.57 | | |
| 5+15 | 25 | 0 | 75 | 0 | 64-QAM | 19.84 | 19.32 | 19.45 | 22.49 | 0.1774 |
| 5+15 | 1 | 0 | 1 | 74 | | 15.69 | 15.26 | 15.27 | | |
| 5+15 | 1 | 24 | 1 | 0 | | 20.08 | 22.44 | 19.74 | | |
| 5+15 | 25 | 0 | 75 | 0 | 256-QAM | 17.86 | 17.29 | 17.43 | 18.10 | 0.0646 |
| 5+15 | 1 | 0 | 1 | 74 | | 15.66 | 14.98 | 15.36 | | |
| 5+15 | 1 | 24 | 1 | 0 | | 18.05 | 17.93 | 17.61 | | |
| Limit | EIRP < 1W | | | | | Result | | | Pass | |



| LTE Band 66B_CA Maximum Average Power [dBm] (GT - LC = 0.05 dB) | | | | | | | | | | |
|---|-----------|-----------|---------|-----------|---------|--------|--------|---------|------------|----------|
| BW [MHz] | PCC | | SCC | | Mod | Lowest | Middle | Highest | EIRP (dBm) | EIRP (W) |
| | RB Size | RB Offset | RB Size | RB Offset | | | | | | |
| 10+5 | 50 | 0 | 25 | 0 | QPSK | 20.96 | 20.44 | 20.60 | 22.83 | 0.1919 |
| 10+5 | 1 | 0 | 1 | 24 | | 13.44 | 13.10 | 13.38 | | |
| 10+5 | 1 | 49 | 1 | 0 | | 22.78 | 22.35 | 22.35 | | |
| 10+5 | 50 | 0 | 25 | 0 | 16-QAM | 19.96 | 19.45 | 19.59 | 22.27 | 0.1687 |
| 10+5 | 1 | 0 | 1 | 24 | | 13.70 | 13.49 | 13.75 | | |
| 10+5 | 1 | 49 | 1 | 0 | | 22.22 | 21.90 | 21.61 | | |
| 10+5 | 50 | 0 | 25 | 0 | 64-QAM | 19.96 | 19.44 | 19.63 | 20.21 | 0.1050 |
| 10+5 | 1 | 0 | 1 | 24 | | 13.62 | 13.32 | 13.90 | | |
| 10+5 | 1 | 49 | 1 | 0 | | 20.16 | 19.76 | 19.65 | | |
| 10+5 | 50 | 0 | 25 | 0 | 256-QAM | 17.85 | 17.40 | 17.53 | 17.99 | 0.0630 |
| 10+5 | 1 | 0 | 1 | 24 | | 13.64 | 13.81 | 13.70 | | |
| 10+5 | 1 | 49 | 1 | 0 | | 17.94 | 17.80 | 17.85 | | |
| 5+10 | 25 | 0 | 50 | 0 | QPSK | 20.92 | 20.42 | 20.54 | 22.87 | 0.1936 |
| 5+10 | 1 | 0 | 1 | 49 | | 13.44 | 13.21 | 13.34 | | |
| 5+10 | 1 | 24 | 1 | 0 | | 22.82 | 22.75 | 22.35 | | |
| 5+10 | 25 | 0 | 50 | 0 | 16-QAM | 19.89 | 19.41 | 19.59 | 22.02 | 0.1592 |
| 5+10 | 1 | 0 | 1 | 49 | | 13.88 | 13.59 | 13.78 | | |
| 5+10 | 1 | 24 | 1 | 0 | | 21.97 | 21.73 | 21.66 | | |
| 5+10 | 25 | 0 | 50 | 0 | 64-QAM | 19.84 | 19.42 | 19.53 | 20.21 | 0.1050 |
| 5+10 | 1 | 0 | 1 | 49 | | 13.94 | 13.63 | 13.75 | | |
| 5+10 | 1 | 24 | 1 | 0 | | 20.16 | 19.76 | 19.80 | | |
| 5+10 | 25 | 0 | 50 | 0 | 256-QAM | 17.85 | 17.39 | 17.52 | 18.09 | 0.0644 |
| 5+10 | 1 | 0 | 1 | 49 | | 13.69 | 13.34 | 13.62 | | |
| 5+10 | 1 | 24 | 1 | 0 | | 18.04 | 17.87 | 17.76 | | |
| 5+5 | 25 | 0 | 25 | 0 | QPSK | 21.10 | 20.56 | 20.67 | 22.93 | 0.1963 |
| 5+5 | 1 | 0 | 1 | 24 | | 14.03 | 13.74 | 13.72 | | |
| 5+5 | 1 | 24 | 1 | 0 | | 22.88 | 22.50 | 22.44 | | |
| 5+5 | 25 | 0 | 25 | 0 | 16-QAM | 20.13 | 19.60 | 19.69 | 22.32 | 0.1706 |
| 5+5 | 1 | 0 | 1 | 24 | | 14.47 | 14.04 | 13.94 | | |
| 5+5 | 1 | 24 | 1 | 0 | | 22.27 | 21.82 | 21.60 | | |
| 5+5 | 25 | 0 | 25 | 0 | 64-QAM | 20.12 | 19.55 | 19.67 | 20.26 | 0.1062 |
| 5+5 | 1 | 0 | 1 | 24 | | 14.45 | 14.06 | 14.08 | | |
| 5+5 | 1 | 24 | 1 | 0 | | 20.21 | 19.93 | 19.78 | | |
| 5+5 | 25 | 0 | 25 | 0 | 256-QAM | 17.96 | 17.51 | 17.60 | 18.31 | 0.0678 |
| 5+5 | 1 | 0 | 1 | 24 | | 14.23 | 13.91 | 13.90 | | |
| 5+5 | 1 | 24 | 1 | 0 | | 18.26 | 17.75 | 17.73 | | |
| Limit | EIRP < 1W | | | | | Result | | | Pass | |



| LTE Band 66C_CA Maximum Average Power [dBm] (GT - LC = 0.05 dB) | | | | | | | | | | |
|---|-----------|-----------|---------|-----------|---------|--------|--------|---------|------------|----------|
| BW [MHz] | PCC | | SCC | | Mod | Lowest | Middle | Highest | EIRP (dBm) | EIRP (W) |
| | RB Size | RB Offset | RB Size | RB Offset | | | | | | |
| 20+20 | 100 | 0 | 100 | 0 | QPSK | 20.96 | 20.20 | 20.21 | 22.95 | 0.1972 |
| 20+20 | 1 | 0 | 1 | 99 | | 15.04 | 14.77 | 14.64 | | |
| 20+20 | 1 | 99 | 1 | 0 | | 22.90 | 22.58 | 22.37 | | |
| 20+20 | 100 | 0 | 100 | 0 | 16-QAM | 19.95 | 19.20 | 19.23 | 22.33 | 0.1710 |
| 20+20 | 1 | 0 | 1 | 99 | | 15.42 | 15.20 | 15.02 | | |
| 20+20 | 1 | 99 | 1 | 0 | | 22.28 | 21.90 | 21.72 | | |
| 20+20 | 100 | 0 | 100 | 0 | 64-QAM | 19.96 | 19.23 | 19.24 | 20.22 | 0.1052 |
| 20+20 | 1 | 0 | 1 | 99 | | 15.50 | 15.24 | 14.94 | | |
| 20+20 | 1 | 99 | 1 | 0 | | 20.17 | 20.02 | 19.78 | | |
| 20+20 | 100 | 0 | 100 | 0 | 256-QAM | 17.92 | 17.37 | 17.29 | 18.22 | 0.0664 |
| 20+20 | 1 | 0 | 1 | 99 | | 15.42 | 15.11 | 14.85 | | |
| 20+20 | 1 | 99 | 1 | 0 | | 18.17 | 17.93 | 17.67 | | |
| 20+15 | 100 | 0 | 75 | 0 | QPSK | 21.03 | 20.27 | 20.35 | 23.01 | 0.2000 |
| 20+15 | 1 | 0 | 1 | 74 | | 15.23 | 14.96 | 14.86 | | |
| 20+15 | 1 | 74 | 1 | 0 | | 22.96 | 22.60 | 22.38 | | |
| 20+15 | 100 | 0 | 75 | 0 | 16-QAM | 20.03 | 19.30 | 19.35 | 22.32 | 0.1706 |
| 20+15 | 1 | 0 | 1 | 74 | | 15.74 | 15.19 | 15.08 | | |
| 20+15 | 1 | 74 | 1 | 0 | | 22.27 | 22.09 | 21.88 | | |
| 20+15 | 100 | 0 | 75 | 0 | 64-QAM | 20.06 | 19.30 | 19.40 | 20.24 | 0.1057 |
| 20+15 | 1 | 0 | 1 | 74 | | 15.67 | 15.14 | 15.14 | | |
| 20+15 | 1 | 74 | 1 | 0 | | 20.19 | 19.75 | 19.62 | | |
| 20+15 | 100 | 0 | 75 | 0 | 256-QAM | 18.01 | 17.33 | 17.39 | 18.18 | 0.0658 |
| 20+15 | 1 | 0 | 1 | 74 | | 15.82 | 15.08 | 14.98 | | |
| 20+15 | 1 | 74 | 1 | 0 | | 18.13 | 17.60 | 17.63 | | |
| 15+20 | 75 | 0 | 100 | 0 | QPSK | 20.95 | 20.33 | 20.30 | 23.03 | 0.2009 |
| 15+20 | 1 | 0 | 1 | 99 | | 15.18 | 14.78 | 14.62 | | |
| 15+20 | 1 | 74 | 1 | 0 | | 22.98 | 22.57 | 22.41 | | |
| 15+20 | 75 | 0 | 100 | 0 | 16-QAM | 19.97 | 19.23 | 19.27 | 22.28 | 0.1690 |
| 15+20 | 1 | 0 | 1 | 99 | | 15.70 | 15.12 | 15.09 | | |
| 15+20 | 1 | 74 | 1 | 0 | | 22.23 | 21.87 | 21.88 | | |
| 15+20 | 75 | 0 | 100 | 0 | 64-QAM | 19.98 | 19.19 | 19.27 | 20.25 | 0.1059 |
| 15+20 | 1 | 0 | 1 | 99 | | 15.54 | 15.11 | 15.01 | | |
| 15+20 | 1 | 74 | 1 | 0 | | 20.20 | 20.01 | 19.85 | | |
| 15+20 | 75 | 0 | 100 | 0 | 256-QAM | 17.95 | 17.26 | 17.31 | 18.27 | 0.0671 |
| 15+20 | 1 | 0 | 1 | 99 | | 15.38 | 14.93 | 14.95 | | |
| 15+20 | 1 | 74 | 1 | 0 | | 18.22 | 18.08 | 17.81 | | |
| Limit | EIRP < 1W | | | | | Result | | | Pass | |



| LTE Band 66C_CA Maximum Average Power [dBm] (GT - LC = 0.05 dB) | | | | | | | | | | |
|---|-----------|-----------|---------|-----------|---------|--------|--------|---------|------------|----------|
| BW [MHz] | PCC | | SCC | | Mod | Lowest | Middle | Highest | EIRP (dBm) | EIRP (W) |
| | RB Size | RB Offset | RB Size | RB Offset | | | | | | |
| 20+10 | 100 | 0 | 50 | 0 | QPSK | 21.02 | 20.33 | 20.46 | 23.01 | 0.2000 |
| 20+10 | 1 | 0 | 1 | 49 | | 15.20 | 14.92 | 14.95 | | |
| 20+10 | 1 | 99 | 1 | 0 | | 22.96 | 22.50 | 22.35 | | |
| 20+10 | 100 | 0 | 50 | 0 | 16-QAM | 20.04 | 19.26 | 19.44 | 22.34 | 0.1714 |
| 20+10 | 1 | 0 | 1 | 49 | | 15.61 | 15.07 | 15.41 | | |
| 20+10 | 1 | 99 | 1 | 0 | | 22.29 | 21.82 | 21.74 | | |
| 20+10 | 100 | 0 | 50 | 0 | 64-QAM | 19.98 | 19.27 | 19.44 | 20.28 | 0.1067 |
| 20+10 | 1 | 0 | 1 | 49 | | 15.50 | 15.15 | 14.26 | | |
| 20+10 | 1 | 99 | 1 | 0 | | 20.23 | 20.03 | 19.68 | | |
| 20+10 | 100 | 0 | 50 | 0 | 256-QAM | 17.94 | 17.27 | 17.46 | 18.32 | 0.0679 |
| 20+10 | 1 | 0 | 1 | 49 | | 15.47 | 15.16 | 15.29 | | |
| 20+10 | 1 | 99 | 1 | 0 | | 18.27 | 17.69 | 17.58 | | |
| 10+20 | 50 | 0 | 100 | 0 | QPSK | 20.95 | 20.28 | 20.29 | 22.87 | 0.1936 |
| 10+20 | 1 | 0 | 1 | 99 | | 15.15 | 14.78 | 14.70 | | |
| 10+20 | 1 | 49 | 1 | 0 | | 22.82 | 22.57 | 22.47 | | |
| 10+20 | 50 | 0 | 100 | 0 | 16-QAM | 19.92 | 19.28 | 19.30 | 22.21 | 0.1663 |
| 10+20 | 1 | 0 | 1 | 99 | | 15.71 | 14.81 | 15.06 | | |
| 10+20 | 1 | 49 | 1 | 0 | | 22.16 | 21.71 | 21.84 | | |
| 10+20 | 50 | 0 | 100 | 0 | 64-QAM | 19.93 | 19.20 | 19.35 | 20.24 | 0.1057 |
| 10+20 | 1 | 0 | 1 | 99 | | 15.53 | 15.18 | 15.11 | | |
| 10+20 | 1 | 49 | 1 | 0 | | 20.19 | 20.08 | 19.81 | | |
| 10+20 | 50 | 0 | 100 | 0 | 256-QAM | 17.88 | 17.28 | 17.33 | 18.31 | 0.0678 |
| 10+20 | 1 | 0 | 1 | 99 | | 15.48 | 15.08 | 14.99 | | |
| 10+20 | 1 | 49 | 1 | 0 | | 18.08 | 18.26 | 17.69 | | |
| 20+5 | 100 | 0 | 25 | 0 | QPSK | 20.98 | 20.34 | 20.52 | 22.91 | 0.1954 |
| 20+5 | 1 | 0 | 1 | 24 | | 15.25 | 15.01 | 15.10 | | |
| 20+5 | 1 | 99 | 1 | 0 | | 22.86 | 22.38 | 22.28 | | |
| 20+5 | 100 | 0 | 25 | 0 | 16-QAM | 19.96 | 19.29 | 19.62 | 22.26 | 0.1683 |
| 20+5 | 1 | 0 | 1 | 24 | | 15.67 | 15.41 | 15.48 | | |
| 20+5 | 1 | 99 | 1 | 0 | | 22.21 | 21.56 | 21.71 | | |
| 20+5 | 100 | 0 | 25 | 0 | 64-QAM | 19.97 | 19.28 | 19.57 | 20.18 | 0.1042 |
| 20+5 | 1 | 0 | 1 | 24 | | 15.71 | 15.47 | 15.49 | | |
| 20+5 | 1 | 99 | 1 | 0 | | 20.13 | 19.80 | 19.60 | | |
| 20+5 | 100 | 0 | 25 | 0 | 256-QAM | 17.93 | 17.34 | 17.56 | 18.16 | 0.0655 |
| 20+5 | 1 | 0 | 1 | 24 | | 15.43 | 15.24 | 15.38 | | |
| 20+5 | 1 | 99 | 1 | 0 | | 18.11 | 17.89 | 17.54 | | |
| Limit | EIRP < 1W | | | | | Result | | | Pass | |



| LTE Band 66C_CA Maximum Average Power [dBm] (GT - LC = 0.05 dB) | | | | | | | | | | |
|---|-----------|-----------|---------|-----------|---------|--------|--------|---------|------------|----------|
| BW [MHz] | PCC | | SCC | | Mod | Lowest | Middle | Highest | EIRP (dBm) | EIRP (W) |
| | RB Size | RB Offset | RB Size | RB Offset | | | | | | |
| 5+20 | 25 | 0 | 100 | 0 | QPSK | 20.91 | 20.30 | 20.36 | 22.86 | 0.1932 |
| 5+20 | 1 | 0 | 1 | 99 | | 15.23 | 14.89 | 14.63 | | |
| 5+20 | 1 | 24 | 1 | 0 | | 22.81 | 22.78 | 22.42 | | |
| 5+20 | 25 | 0 | 100 | 0 | 16-QAM | 19.90 | 19.30 | 19.38 | 22.23 | 0.1671 |
| 5+20 | 1 | 0 | 1 | 99 | | 15.58 | 15.14 | 15.14 | | |
| 5+20 | 1 | 24 | 1 | 0 | | 22.18 | 21.86 | 21.86 | | |
| 5+20 | 25 | 0 | 100 | 0 | 64-QAM | 19.87 | 19.30 | 19.35 | 20.08 | 0.1019 |
| 5+20 | 1 | 0 | 1 | 99 | | 15.63 | 15.16 | 15.08 | | |
| 5+20 | 1 | 24 | 1 | 0 | | 20.03 | 19.75 | 19.67 | | |
| 5+20 | 25 | 0 | 100 | 0 | 256-QAM | 17.84 | 17.34 | 17.40 | 18.12 | 0.0649 |
| 5+20 | 1 | 0 | 1 | 99 | | 15.56 | 15.31 | 15.02 | | |
| 5+20 | 1 | 24 | 1 | 0 | | 18.07 | 17.73 | 17.62 | | |
| Limit | EIRP < 1W | | | | | Result | | | Pass | |



| LTE Band 66C_CA Maximum Average Power [dBm] (GT - LC = 0.05 dB) | | | | | | | | | | |
|---|-----------|-----------|---------|-----------|---------|--------|--------|---------|------------|----------|
| BW [MHz] | PCC | | SCC | | Mod | Lowest | Middle | Highest | EIRP (dBm) | EIRP (W) |
| | RB Size | RB Offset | RB Size | RB Offset | | | | | | |
| 15+10 | 75 | 0 | 50 | 0 | QPSK | 20.96 | 20.36 | 20.47 | 23.02 | 0.2004 |
| 15+10 | 1 | 0 | 1 | 49 | | 15.17 | 14.91 | 14.99 | | |
| 15+10 | 1 | 74 | 1 | 0 | | 22.97 | 22.56 | 22.43 | | |
| 15+10 | 75 | 0 | 50 | 0 | 16-QAM | 19.94 | 19.37 | 19.51 | 22.19 | 0.1656 |
| 15+10 | 1 | 0 | 1 | 49 | | 15.66 | 15.33 | 15.51 | | |
| 15+10 | 1 | 74 | 1 | 0 | | 22.14 | 21.74 | 21.83 | | |
| 15+10 | 75 | 0 | 50 | 0 | 64-QAM | 19.93 | 19.20 | 19.50 | 20.27 | 0.1064 |
| 15+10 | 1 | 0 | 1 | 49 | | 15.56 | 15.27 | 15.38 | | |
| 15+10 | 1 | 74 | 1 | 0 | | 20.22 | 19.81 | 19.65 | | |
| 15+10 | 75 | 0 | 50 | 0 | 256-QAM | 17.91 | 17.28 | 17.48 | 18.20 | 0.0661 |
| 15+10 | 1 | 0 | 1 | 49 | | 15.51 | 15.13 | 15.28 | | |
| 15+10 | 1 | 74 | 1 | 0 | | 18.15 | 17.82 | 17.70 | | |
| 10+15 | 50 | 0 | 75 | 0 | QPSK | 20.85 | 20.22 | 20.38 | 22.84 | 0.1923 |
| 10+15 | 1 | 0 | 1 | 74 | | 15.10 | 14.90 | 14.80 | | |
| 10+15 | 1 | 49 | 1 | 0 | | 22.79 | 22.60 | 22.37 | | |
| 10+15 | 50 | 0 | 75 | 0 | 16-QAM | 19.88 | 19.43 | 19.41 | 22.29 | 0.1694 |
| 10+15 | 1 | 0 | 1 | 74 | | 15.52 | 15.53 | 15.12 | | |
| 10+15 | 1 | 49 | 1 | 0 | | 22.24 | 22.12 | 21.63 | | |
| 10+15 | 50 | 0 | 75 | 0 | 64-QAM | 19.91 | 19.23 | 19.43 | 20.22 | 0.1052 |
| 10+15 | 1 | 0 | 1 | 74 | | 15.60 | 15.02 | 15.26 | | |
| 10+15 | 1 | 49 | 1 | 0 | | 20.17 | 20.07 | 19.77 | | |
| 10+15 | 50 | 0 | 75 | 0 | 256-QAM | 17.87 | 17.25 | 17.40 | 18.10 | 0.0646 |
| 10+15 | 1 | 0 | 1 | 74 | | 15.55 | 14.92 | 15.11 | | |
| 10+15 | 1 | 49 | 1 | 0 | | 18.05 | 17.88 | 17.66 | | |
| 15+15 | 75 | 0 | 75 | 0 | QPSK | 20.96 | 20.28 | 20.38 | 23.02 | 0.2004 |
| 15+15 | 1 | 0 | 1 | 74 | | 15.24 | 14.89 | 14.88 | | |
| 15+15 | 1 | 74 | 1 | 0 | | 22.97 | 22.70 | 22.41 | | |
| 15+15 | 75 | 0 | 75 | 0 | 16-QAM | 19.97 | 19.34 | 19.38 | 22.41 | 0.1742 |
| 15+15 | 1 | 0 | 1 | 74 | | 15.72 | 15.24 | 15.31 | | |
| 15+15 | 1 | 74 | 1 | 0 | | 22.36 | 22.00 | 21.78 | | |
| 15+15 | 75 | 0 | 75 | 0 | 64-QAM | 19.98 | 19.38 | 19.40 | 20.37 | 0.1089 |
| 15+15 | 1 | 0 | 1 | 74 | | 15.58 | 15.10 | 15.12 | | |
| 15+15 | 1 | 74 | 1 | 0 | | 20.32 | 19.84 | 19.73 | | |
| 15+15 | 75 | 0 | 75 | 0 | 256-QAM | 17.98 | 17.34 | 17.42 | 18.22 | 0.0664 |
| 15+15 | 1 | 0 | 1 | 74 | | 15.54 | 15.12 | 15.14 | | |
| 15+15 | 1 | 74 | 1 | 0 | | 18.17 | 17.93 | 17.71 | | |
| Limit | EIRP < 1W | | | | | Result | | | Pass | |



| LTE Band 7C_CA Maximum Average Power [dBm] (GT - LC = 0.32 dB) | | | | | | | | | | |
|--|-----------|-----------|---------|-----------|---------|--------|--------|---------|------------|----------|
| BW [MHz] | PCC | | SCC | | Mod | Lowest | Middle | Highest | EIRP (dBm) | EIRP (W) |
| | RB Size | RB Offset | RB Size | RB Offset | | | | | | |
| 20+20 | 100 | 0 | 100 | 0 | QPSK | 20.79 | 20.55 | 20.79 | 23.03 | 0.2009 |
| 20+20 | 1 | 0 | 1 | 99 | | 14.94 | 14.56 | 14.85 | | |
| 20+20 | 1 | 99 | 1 | 0 | | 22.71 | 22.53 | 22.58 | | |
| 20+20 | 100 | 0 | 100 | 0 | 16-QAM | 19.72 | 19.44 | 19.73 | 22.64 | 0.1837 |
| 20+20 | 1 | 0 | 1 | 99 | | 15.44 | 15.06 | 15.58 | | |
| 20+20 | 1 | 99 | 1 | 0 | | 22.17 | 22.32 | 22.02 | | |
| 20+20 | 100 | 0 | 100 | 0 | 64-QAM | 19.81 | 19.50 | 19.70 | 20.57 | 0.1140 |
| 20+20 | 1 | 0 | 1 | 99 | | 15.49 | 15.06 | 15.48 | | |
| 20+20 | 1 | 99 | 1 | 0 | | 20.25 | 20.02 | 19.98 | | |
| 20+20 | 100 | 0 | 100 | 0 | 256-QAM | 17.46 | 17.82 | 17.54 | 18.23 | 0.0665 |
| 20+20 | 1 | 0 | 1 | 99 | | 15.33 | 14.96 | 15.30 | | |
| 20+20 | 1 | 99 | 1 | 0 | | 17.91 | 17.72 | 17.84 | | |
| 20+15 | 100 | 0 | 75 | 0 | QPSK | 20.72 | 20.61 | 20.68 | 23.01 | 0.2000 |
| 20+15 | 1 | 0 | 1 | 74 | | 14.95 | 14.72 | 14.80 | | |
| 20+15 | 1 | 99 | 1 | 0 | | 22.69 | 22.64 | 22.38 | | |
| 20+15 | 100 | 0 | 75 | 0 | 16-QAM | 19.67 | 19.62 | 19.76 | 22.42 | 0.1746 |
| 20+15 | 1 | 0 | 1 | 74 | | 15.55 | 15.43 | 15.47 | | |
| 20+15 | 1 | 99 | 1 | 0 | | 22.10 | 21.84 | 21.97 | | |
| 20+15 | 100 | 0 | 75 | 0 | 64-QAM | 19.67 | 19.76 | 19.67 | 20.52 | 0.1127 |
| 20+15 | 1 | 0 | 1 | 74 | | 15.58 | 15.34 | 15.51 | | |
| 20+15 | 1 | 99 | 1 | 0 | | 20.20 | 20.13 | 19.95 | | |
| 20+15 | 100 | 0 | 75 | 0 | 256-QAM | 17.46 | 17.53 | 17.65 | 18.12 | 0.0649 |
| 20+15 | 1 | 0 | 1 | 74 | | 15.30 | 15.17 | 15.06 | | |
| 20+15 | 1 | 99 | 1 | 0 | | 17.80 | 17.80 | 17.69 | | |
| 15+20 | 75 | 0 | 100 | 0 | QPSK | 20.53 | 20.46 | 20.57 | 22.96 | 0.1977 |
| 15+20 | 1 | 0 | 1 | 99 | | 14.75 | 14.63 | 14.62 | | |
| 15+20 | 1 | 74 | 1 | 0 | | 22.64 | 22.53 | 22.51 | | |
| 15+20 | 75 | 0 | 100 | 0 | 16-QAM | 19.51 | 19.54 | 19.49 | 22.37 | 0.1726 |
| 15+20 | 1 | 0 | 1 | 99 | | 15.34 | 15.26 | 15.34 | | |
| 15+20 | 1 | 74 | 1 | 0 | | 22.05 | 21.71 | 21.96 | | |
| 15+20 | 75 | 0 | 100 | 0 | 64-QAM | 19.56 | 19.56 | 19.56 | 20.45 | 0.1109 |
| 15+20 | 1 | 0 | 1 | 99 | | 15.43 | 15.04 | 14.97 | | |
| 15+20 | 1 | 74 | 1 | 0 | | 20.13 | 20.01 | 19.91 | | |
| 15+20 | 75 | 0 | 100 | 0 | 256-QAM | 17.52 | 17.49 | 17.53 | 18.34 | 0.0682 |
| 15+20 | 1 | 0 | 1 | 99 | | 15.12 | 14.92 | 15.23 | | |
| 15+20 | 1 | 74 | 1 | 0 | | 17.87 | 17.92 | 18.02 | | |
| Limit | EIRP < 2W | | | | | Result | | | Pass | |



| LTE Band 7C_CA Maximum Average Power [dBm] (GT - LC = 0.32 dB) | | | | | | | | | | |
|--|-----------|-----------|---------|-----------|---------|--------|--------|---------|------------|----------|
| BW [MHz] | PCC | | SCC | | Mod | Lowest | Middle | Highest | EIRP (dBm) | EIRP (W) |
| | RB Size | RB Offset | RB Size | RB Offset | | | | | | |
| 20+10 | 100 | 0 | 75 | 0 | QPSK | 20.76 | 20.63 | 21.02 | 23.03 | 0.2009 |
| 20+10 | 1 | 0 | 1 | 74 | | 14.85 | 14.98 | 15.06 | | |
| 20+10 | 1 | 99 | 1 | 0 | | 22.71 | 22.54 | 22.66 | | |
| 20+10 | 100 | 0 | 75 | 0 | 16-QAM | 19.75 | 19.69 | 20.00 | 22.59 | 0.1816 |
| 20+10 | 1 | 0 | 1 | 74 | | 15.31 | 15.51 | 15.87 | | |
| 20+10 | 1 | 99 | 1 | 0 | | 22.25 | 22.04 | 22.27 | | |
| 20+10 | 100 | 0 | 75 | 0 | 64-QAM | 19.74 | 19.62 | 19.99 | 20.61 | 0.1151 |
| 20+10 | 1 | 0 | 1 | 74 | | 15.38 | 15.44 | 15.86 | | |
| 20+10 | 1 | 99 | 1 | 0 | | 20.29 | 19.96 | 20.21 | | |
| 20+10 | 100 | 0 | 75 | 0 | 256-QAM | 17.54 | 17.55 | 17.91 | 18.32 | 0.0679 |
| 20+10 | 1 | 0 | 1 | 74 | | 15.19 | 15.40 | 15.93 | | |
| 20+10 | 1 | 99 | 1 | 0 | | 18.00 | 17.74 | 17.86 | | |
| 10+20 | 75 | 0 | 100 | 0 | QPSK | 20.62 | 20.63 | 20.66 | 22.91 | 0.1954 |
| 10+20 | 1 | 0 | 1 | 99 | | 14.61 | 14.70 | 14.65 | | |
| 10+20 | 1 | 74 | 1 | 0 | | 22.59 | 22.53 | 22.49 | | |
| 10+20 | 75 | 0 | 100 | 0 | 16-QAM | 19.64 | 19.55 | 19.64 | 22.51 | 0.1782 |
| 10+20 | 1 | 0 | 1 | 99 | | 14.97 | 15.48 | 15.36 | | |
| 10+20 | 1 | 74 | 1 | 0 | | 22.19 | 22.02 | 22.13 | | |
| 10+20 | 75 | 0 | 100 | 0 | 64-QAM | 19.61 | 19.81 | 19.86 | 20.38 | 0.1091 |
| 10+20 | 1 | 0 | 1 | 99 | | 15.09 | 15.29 | 14.94 | | |
| 10+20 | 1 | 74 | 1 | 0 | | 20.06 | 19.86 | 19.90 | | |
| 10+20 | 75 | 0 | 100 | 0 | 256-QAM | 17.55 | 17.65 | 17.62 | 18.21 | 0.0662 |
| 10+20 | 1 | 0 | 1 | 99 | | 15.21 | 15.16 | 14.87 | | |
| 10+20 | 1 | 74 | 1 | 0 | | 17.73 | 17.62 | 17.89 | | |
| 15+15 | 75 | 0 | 100 | 0 | QPSK | 20.63 | 20.50 | 20.85 | 22.92 | 0.1959 |
| 15+15 | 1 | 0 | 1 | 99 | | 14.76 | 14.71 | 14.82 | | |
| 15+15 | 1 | 74 | 1 | 0 | | 22.60 | 22.48 | 22.54 | | |
| 15+15 | 75 | 0 | 100 | 0 | 16-QAM | 19.76 | 19.48 | 19.99 | 22.44 | 0.1754 |
| 15+15 | 1 | 0 | 1 | 99 | | 15.20 | 15.47 | 15.37 | | |
| 15+15 | 1 | 74 | 1 | 0 | | 22.10 | 21.98 | 22.12 | | |
| 15+15 | 75 | 0 | 100 | 0 | 64-QAM | 19.70 | 19.50 | 19.90 | 20.31 | 0.1074 |
| 15+15 | 1 | 0 | 1 | 99 | | 15.32 | 15.27 | 15.39 | | |
| 15+15 | 1 | 74 | 1 | 0 | | 19.99 | 19.98 | 19.98 | | |
| 15+15 | 75 | 0 | 100 | 0 | 256-QAM | 17.47 | 17.69 | 17.62 | 18.29 | 0.0675 |
| 15+15 | 1 | 0 | 1 | 99 | | 15.12 | 15.20 | 15.14 | | |
| 15+15 | 1 | 74 | 1 | 0 | | 17.97 | 17.77 | 17.81 | | |
| Limit | EIRP < 2W | | | | | Result | | | Pass | |



| LTE Band 7C_CA Maximum Average Power [dBm] (GT - LC = 0.32 dB) | | | | | | | | | | |
|--|-----------|-----------|---------|-----------|---------|--------|--------|---------|------------|----------|
| BW [MHz] | PCC | | SCC | | Mod | Lowest | Middle | Highest | EIRP (dBm) | EIRP (W) |
| | RB Size | RB Offset | RB Size | RB Offset | | | | | | |
| 15+10 | 75 | 0 | 100 | 0 | QPSK | 20.61 | 20.60 | 20.93 | 23.00 | 0.1995 |
| 15+10 | 1 | 0 | 1 | 99 | | 14.67 | 15.03 | 14.95 | | |
| 15+10 | 1 | 74 | 1 | 0 | | 22.68 | 22.55 | 22.57 | | |
| 15+10 | 75 | 0 | 100 | 0 | 16-QAM | 19.61 | 19.60 | 19.85 | 22.60 | 0.1820 |
| 15+10 | 1 | 0 | 1 | 99 | | 15.37 | 15.74 | 15.61 | | |
| 15+10 | 1 | 74 | 1 | 0 | | 22.28 | 22.01 | 22.09 | | |
| 15+10 | 75 | 0 | 100 | 0 | 64-QAM | 19.64 | 19.61 | 19.88 | 20.47 | 0.1114 |
| 15+10 | 1 | 0 | 1 | 99 | | 15.19 | 15.58 | 15.58 | | |
| 15+10 | 1 | 74 | 1 | 0 | | 20.15 | 19.66 | 20.06 | | |
| 15+10 | 75 | 0 | 100 | 0 | 256-QAM | 17.53 | 17.68 | 17.97 | 18.51 | 0.0710 |
| 15+10 | 1 | 0 | 1 | 99 | | 14.98 | 15.45 | 15.54 | | |
| 15+10 | 1 | 74 | 1 | 0 | | 18.19 | 17.86 | 17.90 | | |
| Limit | EIRP < 2W | | | | | Result | | | Pass | |



| LTE Band 38C_CA Maximum Average Power [dBm] (GT - LC = 0.9 dB) | | | | | | | | | | |
|--|-----------|-----------|---------|-----------|---------|--------|--------|---------|------------|----------|
| BW [MHz] | PCC | | SCC | | Mod | Lowest | Middle | Highest | EIRP (dBm) | EIRP (W) |
| | RB Size | RB Offset | RB Size | RB Offset | | | | | | |
| 20+20 | 100 | 0 | 100 | 0 | QPSK | 19.57 | 19.59 | 19.57 | 20.49 | 0.1119 |
| 20+20 | 1 | 0 | 1 | 99 | | 9.11 | 9.12 | 9.11 | | |
| 20+20 | 1 | 99 | 1 | 0 | | 8.91 | 8.90 | 8.92 | | |
| 20+20 | 100 | 0 | 100 | 0 | 16-QAM | 18.63 | 18.63 | 18.63 | 19.53 | 0.0897 |
| 20+20 | 1 | 0 | 1 | 99 | | 9.58 | 9.87 | 9.77 | | |
| 20+20 | 1 | 99 | 1 | 0 | | 9.63 | 9.70 | 9.56 | | |
| 20+20 | 100 | 0 | 100 | 0 | 64-QAM | 18.63 | 18.63 | 18.59 | 19.53 | 0.0897 |
| 20+20 | 1 | 0 | 1 | 99 | | 8.42 | 8.42 | 8.29 | | |
| 20+20 | 1 | 99 | 1 | 0 | | 8.21 | 8.21 | 8.07 | | |
| 20+20 | 100 | 0 | 100 | 0 | 256-QAM | 17.63 | 17.61 | 17.59 | 18.53 | 0.0713 |
| 20+20 | 1 | 0 | 1 | 99 | | 7.31 | 7.12 | 7.30 | | |
| 20+20 | 1 | 99 | 1 | 0 | | 7.11 | 6.91 | 7.06 | | |
| 15+15 | 75 | 0 | 75 | 0 | QPSK | 19.38 | 19.33 | 19.17 | 20.28 | 0.1067 |
| 15+15 | 1 | 0 | 1 | 74 | | 8.85 | 8.86 | 8.85 | | |
| 15+15 | 1 | 74 | 1 | 0 | | 8.79 | 8.74 | 8.51 | | |
| 15+15 | 75 | 0 | 75 | 0 | 16-QAM | 18.49 | 18.41 | 18.38 | 19.39 | 0.0869 |
| 15+15 | 1 | 0 | 1 | 74 | | 9.79 | 9.51 | 9.34 | | |
| 15+15 | 1 | 74 | 1 | 0 | | 9.65 | 9.38 | 9.23 | | |
| 15+15 | 75 | 0 | 75 | 0 | 64-QAM | 18.47 | 18.38 | 18.27 | 19.37 | 0.0865 |
| 15+15 | 1 | 0 | 1 | 74 | | 8.33 | 8.40 | 8.08 | | |
| 15+15 | 1 | 74 | 1 | 0 | | 8.14 | 8.05 | 7.92 | | |
| 15+15 | 75 | 0 | 75 | 0 | 256-QAM | 17.43 | 17.43 | 17.26 | 18.33 | 0.0681 |
| 15+15 | 1 | 0 | 1 | 74 | | 7.23 | 7.01 | 7.11 | | |
| 15+15 | 1 | 74 | 1 | 0 | | 7.06 | 6.80 | 6.78 | | |
| Limit | EIRP < 2W | | | | | Result | | | Pass | |



| LTE Band 41C_CA Maximum Average Power [dBm] (GT - LC = 0.84 dB) | | | | | | | | | | |
|---|-----------|-----------|---------|-----------|---------|--------|--------|---------|------------|----------|
| BW [MHz] | PCC | | SCC | | Mod | Lowest | Middle | Highest | EIRP (dBm) | EIRP (W) |
| | RB Size | RB Offset | RB Size | RB Offset | | | | | | |
| 20+20 | 100 | 0 | 100 | 0 | QPSK | 19.32 | 19.24 | 19.89 | 20.73 | 0.1183 |
| 20+20 | 1 | 0 | 1 | 99 | | 8.76 | 9.07 | 8.82 | | |
| 20+20 | 1 | 99 | 1 | 0 | | 8.68 | 8.93 | 8.76 | | |
| 20+20 | 100 | 0 | 100 | 0 | 16-QAM | 18.32 | 18.27 | 18.44 | 19.28 | 0.0847 |
| 20+20 | 1 | 0 | 1 | 99 | | 9.24 | 9.78 | 9.51 | | |
| 20+20 | 1 | 99 | 1 | 0 | | 9.20 | 9.51 | 9.41 | | |
| 20+20 | 100 | 0 | 100 | 0 | 64-QAM | 18.32 | 18.27 | 18.37 | 19.21 | 0.0834 |
| 20+20 | 1 | 0 | 1 | 99 | | 8.11 | 8.56 | 8.31 | | |
| 20+20 | 1 | 99 | 1 | 0 | | 8.08 | 8.24 | 8.23 | | |
| 20+20 | 100 | 0 | 100 | 0 | 256-QAM | 17.31 | 17.26 | 17.41 | 18.25 | 0.0668 |
| 20+20 | 1 | 0 | 1 | 99 | | 6.81 | 7.19 | 7.02 | | |
| 20+20 | 1 | 99 | 1 | 0 | | 6.59 | 7.02 | 6.94 | | |
| 20+15 | 100 | 0 | 75 | 0 | QPSK | 19.22 | 19.26 | 19.37 | 20.21 | 0.1050 |
| 20+15 | 1 | 0 | 1 | 74 | | 8.67 | 9.09 | 8.75 | | |
| 20+15 | 1 | 99 | 1 | 0 | | 8.65 | 8.89 | 8.70 | | |
| 20+15 | 100 | 0 | 75 | 0 | 16-QAM | 18.23 | 18.28 | 18.31 | 19.15 | 0.0822 |
| 20+15 | 1 | 0 | 1 | 74 | | 9.11 | 9.41 | 9.30 | | |
| 20+15 | 1 | 99 | 1 | 0 | | 9.04 | 9.38 | 9.05 | | |
| 20+15 | 100 | 0 | 75 | 0 | 64-QAM | 18.23 | 18.26 | 18.32 | 19.16 | 0.0824 |
| 20+15 | 1 | 0 | 1 | 74 | | 7.91 | 8.64 | 8.25 | | |
| 20+15 | 1 | 99 | 1 | 0 | | 7.93 | 8.34 | 7.82 | | |
| 20+15 | 100 | 0 | 75 | 0 | 256-QAM | 17.25 | 17.28 | 17.33 | 18.17 | 0.0656 |
| 20+15 | 1 | 0 | 1 | 74 | | 6.69 | 7.03 | 6.91 | | |
| 20+15 | 1 | 99 | 1 | 0 | | 6.67 | 7.10 | 7.06 | | |
| 15+20 | 75 | 0 | 100 | 0 | QPSK | 19.22 | 19.25 | 19.28 | 20.12 | 0.1028 |
| 15+20 | 1 | 0 | 1 | 99 | | 8.63 | 9.04 | 8.66 | | |
| 15+20 | 1 | 74 | 1 | 0 | | 8.59 | 8.93 | 8.63 | | |
| 15+20 | 75 | 0 | 100 | 0 | 16-QAM | 18.20 | 18.25 | 18.21 | 19.09 | 0.0811 |
| 15+20 | 1 | 0 | 1 | 99 | | 9.14 | 9.49 | 9.30 | | |
| 15+20 | 1 | 74 | 1 | 0 | | 8.98 | 9.38 | 9.28 | | |
| 15+20 | 75 | 0 | 100 | 0 | 64-QAM | 18.22 | 18.27 | 18.21 | 19.11 | 0.0815 |
| 15+20 | 1 | 0 | 1 | 99 | | 8.08 | 8.22 | 8.14 | | |
| 15+20 | 1 | 74 | 1 | 0 | | 7.94 | 8.04 | 8.14 | | |
| 15+20 | 75 | 0 | 100 | 0 | 256-QAM | 17.21 | 17.25 | 17.23 | 18.09 | 0.0644 |
| 15+20 | 1 | 0 | 1 | 99 | | 6.51 | 7.17 | 7.10 | | |
| 15+20 | 1 | 74 | 1 | 0 | | 6.74 | 6.95 | 6.78 | | |
| Limit | EIRP < 2W | | | | | Result | | | Pass | |



| LTE Band 41C_CA Maximum Average Power [dBm] (GT - LC = 0.84 dB) | | | | | | | | | | |
|---|-----------|-----------|---------|-----------|---------|--------|--------|---------|------------|----------|
| BW [MHz] | PCC | | SCC | | Mod | Lowest | Middle | Highest | EIRP (dBm) | EIRP (W) |
| | RB Size | RB Offset | RB Size | RB Offset | | | | | | |
| 20+10 | 100 | 0 | 50 | 0 | QPSK | 19.25 | 19.31 | 19.31 | 20.15 | 0.1035 |
| 20+10 | 1 | 0 | 1 | 49 | | 8.67 | 9.10 | 8.76 | | |
| 20+10 | 1 | 99 | 1 | 0 | | 8.62 | 9.20 | 8.70 | | |
| 20+10 | 100 | 0 | 50 | 0 | 16-QAM | 18.23 | 18.33 | 18.27 | 19.17 | 0.0826 |
| 20+10 | 1 | 0 | 1 | 49 | | 9.16 | 9.51 | 9.24 | | |
| 20+10 | 1 | 99 | 1 | 0 | | 8.93 | 9.30 | 9.18 | | |
| 20+10 | 100 | 0 | 50 | 0 | 64-QAM | 18.21 | 18.30 | 18.27 | 19.14 | 0.0820 |
| 20+10 | 1 | 0 | 1 | 49 | | 7.95 | 8.67 | 8.31 | | |
| 20+10 | 1 | 99 | 1 | 0 | | 7.78 | 8.18 | 8.05 | | |
| 20+10 | 100 | 0 | 50 | 0 | 256-QAM | 17.26 | 17.32 | 17.29 | 18.16 | 0.0655 |
| 20+10 | 1 | 0 | 1 | 49 | | 6.62 | 7.06 | 6.85 | | |
| 20+10 | 1 | 99 | 1 | 0 | | 6.76 | 7.07 | 6.75 | | |
| 10+20 | 50 | 0 | 100 | 0 | QPSK | 19.22 | 19.30 | 19.28 | 20.14 | 0.1033 |
| 10+20 | 1 | 0 | 1 | 99 | | 8.59 | 8.96 | 8.62 | | |
| 10+20 | 1 | 49 | 1 | 0 | | 8.56 | 8.93 | 8.58 | | |
| 10+20 | 50 | 0 | 100 | 0 | 16-QAM | 18.17 | 18.28 | 18.21 | 19.12 | 0.0817 |
| 10+20 | 1 | 0 | 1 | 99 | | 8.95 | 9.23 | 9.04 | | |
| 10+20 | 1 | 49 | 1 | 0 | | 8.96 | 9.14 | 9.21 | | |
| 10+20 | 50 | 0 | 100 | 0 | 64-QAM | 18.20 | 18.31 | 18.16 | 19.15 | 0.0822 |
| 10+20 | 1 | 0 | 1 | 99 | | 7.69 | 8.35 | 8.11 | | |
| 10+20 | 1 | 49 | 1 | 0 | | 8.08 | 8.41 | 7.92 | | |
| 10+20 | 50 | 0 | 100 | 0 | 256-QAM | 17.23 | 17.36 | 17.25 | 18.20 | 0.0661 |
| 10+20 | 1 | 0 | 1 | 99 | | 6.82 | 7.13 | 6.88 | | |
| 10+20 | 1 | 49 | 1 | 0 | | 6.49 | 7.23 | 6.93 | | |
| 20+5 | 100 | 0 | 25 | 0 | QPSK | 19.24 | 19.39 | 19.29 | 20.23 | 0.1054 |
| 20+5 | 1 | 0 | 1 | 24 | | 8.66 | 9.11 | 8.71 | | |
| 20+5 | 1 | 99 | 1 | 0 | | 8.59 | 8.87 | 8.65 | | |
| 20+5 | 100 | 0 | 25 | 0 | 16-QAM | 18.28 | 18.40 | 18.26 | 19.24 | 0.0839 |
| 20+5 | 1 | 0 | 1 | 24 | | 9.26 | 9.58 | 9.22 | | |
| 20+5 | 1 | 99 | 1 | 0 | | 8.96 | 9.43 | 9.13 | | |
| 20+5 | 100 | 0 | 25 | 0 | 64-QAM | 18.26 | 18.39 | 18.19 | 19.23 | 0.0838 |
| 20+5 | 1 | 0 | 1 | 24 | | 7.98 | 8.67 | 8.19 | | |
| 20+5 | 1 | 99 | 1 | 0 | | 7.94 | 8.34 | 7.94 | | |
| 20+5 | 100 | 0 | 25 | 0 | 256-QAM | 17.26 | 17.41 | 17.28 | 18.25 | 0.0668 |
| 20+5 | 1 | 0 | 1 | 24 | | 6.64 | 7.34 | 7.30 | | |
| 20+5 | 1 | 99 | 1 | 0 | | 6.66 | 7.04 | 6.86 | | |
| Limit | EIRP < 2W | | | | | Result | | | Pass | |



| LTE Band 41C_CA Maximum Average Power [dBm] (GT - LC = 0.84 dB) | | | | | | | | | | |
|---|-----------|-----------|---------|-----------|---------|--------|--------|---------|------------|----------|
| BW [MHz] | PCC | | SCC | | Mod | Lowest | Middle | Highest | EIRP (dBm) | EIRP (W) |
| | RB Size | RB Offset | RB Size | RB Offset | | | | | | |
| 5+20 | 25 | 0 | 100 | 0 | QPSK | 19.22 | 19.34 | 19.15 | 20.18 | 0.1042 |
| 5+20 | 1 | 0 | 1 | 99 | | 8.61 | 8.96 | 8.64 | | |
| 5+20 | 1 | 24 | 1 | 0 | | 8.58 | 8.91 | 8.60 | | |
| 5+20 | 25 | 0 | 100 | 0 | 16-QAM | 18.28 | 18.34 | 18.29 | 19.18 | 0.0828 |
| 5+20 | 1 | 0 | 1 | 99 | | 9.05 | 9.21 | 9.13 | | |
| 5+20 | 1 | 24 | 1 | 0 | | 9.06 | 9.21 | 9.07 | | |
| 5+20 | 25 | 0 | 100 | 0 | 64-QAM | 18.26 | 18.34 | 18.21 | 19.18 | 0.0828 |
| 5+20 | 1 | 0 | 1 | 99 | | 7.97 | 8.47 | 8.12 | | |
| 5+20 | 1 | 24 | 1 | 0 | | 8.02 | 8.19 | 7.94 | | |
| 5+20 | 25 | 0 | 100 | 0 | 256-QAM | 17.28 | 17.42 | 17.29 | 18.26 | 0.0670 |
| 5+20 | 1 | 0 | 1 | 99 | | 6.82 | 7.10 | 6.62 | | |
| 5+20 | 1 | 24 | 1 | 0 | | 6.75 | 7.02 | 6.83 | | |
| 15+10 | 75 | 0 | 50 | 0 | QPSK | 19.20 | 19.35 | 19.23 | 20.19 | 0.1045 |
| 15+10 | 1 | 0 | 1 | 49 | | 8.57 | 9.06 | 8.66 | | |
| 15+10 | 1 | 74 | 1 | 0 | | 8.58 | 8.93 | 8.64 | | |
| 15+10 | 75 | 0 | 50 | 0 | 16-QAM | 18.15 | 18.33 | 18.20 | 19.17 | 0.0826 |
| 15+10 | 1 | 0 | 1 | 49 | | 9.03 | 9.47 | 9.25 | | |
| 15+10 | 1 | 74 | 1 | 0 | | 9.01 | 9.25 | 9.10 | | |
| 15+10 | 75 | 0 | 50 | 0 | 64-QAM | 18.18 | 18.35 | 18.21 | 19.19 | 0.0830 |
| 15+10 | 1 | 0 | 1 | 49 | | 8.08 | 8.57 | 8.23 | | |
| 15+10 | 1 | 74 | 1 | 0 | | 7.97 | 8.48 | 8.17 | | |
| 15+10 | 75 | 0 | 50 | 0 | 256-QAM | 17.22 | 17.36 | 17.23 | 18.20 | 0.0661 |
| 15+10 | 1 | 0 | 1 | 49 | | 6.99 | 7.29 | 6.76 | | |
| 15+10 | 1 | 74 | 1 | 0 | | 6.66 | 7.25 | 6.74 | | |
| 10+15 | 50 | 0 | 75 | 0 | QPSK | 19.26 | 19.33 | 19.39 | 20.23 | 0.1054 |
| 10+15 | 1 | 0 | 1 | 74 | | 8.62 | 8.98 | 8.73 | | |
| 10+15 | 1 | 49 | 1 | 0 | | 8.59 | 8.91 | 8.69 | | |
| 10+15 | 50 | 0 | 75 | 0 | 16-QAM | 18.29 | 18.33 | 18.26 | 19.17 | 0.0826 |
| 10+15 | 1 | 0 | 1 | 74 | | 8.93 | 9.45 | 9.22 | | |
| 10+15 | 1 | 49 | 1 | 0 | | 9.07 | 9.35 | 9.05 | | |
| 10+15 | 50 | 0 | 75 | 0 | 64-QAM | 18.30 | 18.37 | 18.35 | 19.21 | 0.0834 |
| 10+15 | 1 | 0 | 1 | 74 | | 8.25 | 8.34 | 7.99 | | |
| 10+15 | 1 | 49 | 1 | 0 | | 8.10 | 8.18 | 7.97 | | |
| 10+15 | 50 | 0 | 75 | 0 | 256-QAM | 17.32 | 17.40 | 17.35 | 18.24 | 0.0667 |
| 10+15 | 1 | 0 | 1 | 74 | | 6.61 | 7.08 | 6.68 | | |
| 10+15 | 1 | 49 | 1 | 0 | | 6.80 | 7.06 | 6.80 | | |
| Limit | EIRP < 2W | | | | | Result | | | Pass | |



| LTE Band 41C_CA Maximum Average Power [dBm] (GT - LC = 0.84 dB) | | | | | | | | | | |
|---|-----------|----|----|----|---------|--------|-------|-------|-------|--------|
| 15+15 | 75 | 0 | 75 | 0 | QPSK | 19.20 | 19.27 | 19.16 | 20.11 | 0.1026 |
| 15+15 | 1 | 0 | 1 | 74 | | 8.63 | 9.05 | 8.68 | | |
| 15+15 | 1 | 74 | 1 | 0 | | 8.60 | 8.95 | 8.64 | | |
| 15+15 | 75 | 0 | 75 | 0 | 16-QAM | 18.16 | 18.25 | 18.20 | 19.09 | 0.0811 |
| 15+15 | 1 | 0 | 1 | 74 | | 9.04 | 9.55 | 9.14 | | |
| 15+15 | 1 | 74 | 1 | 0 | | 9.03 | 9.45 | 9.14 | | |
| 15+15 | 75 | 0 | 75 | 0 | 64-QAM | 18.23 | 18.28 | 18.20 | 19.12 | 0.0817 |
| 15+15 | 1 | 0 | 1 | 74 | | 8.01 | 8.45 | 8.14 | | |
| 15+15 | 1 | 74 | 1 | 0 | | 8.00 | 8.34 | 8.04 | | |
| 15+15 | 75 | 0 | 75 | 0 | 256-QAM | 17.19 | 17.28 | 17.22 | 18.12 | 0.0649 |
| 15+15 | 1 | 0 | 1 | 74 | | 6.80 | 7.19 | 6.75 | | |
| 15+15 | 1 | 74 | 1 | 0 | | 6.80 | 7.07 | 6.75 | | |
| Limit | EIRP < 2W | | | | | Result | | | Pass | |



<ASDIV Antenna>

| LTE Band 2 Maximum Average Power [dBm] (GT - LC = -1.93 dB) | | | | | | | | |
|---|-----------|-----------|---------|--------|--------|---------|------------|----------|
| BW [MHz] | RB Size | RB Offset | Mod | Lowest | Middle | Highest | EIRP (dBm) | EIRP (W) |
| 20 | 1 | 0 | QPSK | 24.41 | 24.76 | 24.53 | 22.83 | 0.1919 |
| 20 | 1 | 49 | | 24.39 | 24.47 | 24.28 | | |
| 20 | 1 | 99 | | 24.35 | 24.23 | 24.47 | | |
| 20 | 50 | 0 | | 23.52 | 23.71 | 23.39 | | |
| 20 | 50 | 24 | | 23.47 | 23.57 | 23.35 | | |
| 20 | 50 | 50 | | 23.44 | 23.39 | 23.32 | | |
| 20 | 100 | 0 | | 23.50 | 23.56 | 23.43 | | |
| 20 | 1 | 0 | 16-QAM | 23.75 | 24.13 | 23.69 | 22.20 | 0.1660 |
| 20 | 1 | 49 | | 23.84 | 23.74 | 23.47 | | |
| 20 | 1 | 99 | | 23.82 | 23.52 | 23.69 | | |
| 20 | 50 | 0 | | 22.52 | 22.74 | 22.40 | | |
| 20 | 50 | 24 | | 22.58 | 22.61 | 22.37 | | |
| 20 | 50 | 50 | | 22.58 | 22.46 | 22.40 | | |
| 20 | 100 | 0 | | 22.50 | 22.58 | 22.38 | | |
| 20 | 1 | 0 | 64-QAM | 22.38 | 23.13 | 22.68 | 21.20 | 0.1318 |
| 20 | 1 | 49 | | 22.59 | 22.76 | 22.38 | | |
| 20 | 1 | 99 | | 22.64 | 22.50 | 22.62 | | |
| 20 | 50 | 0 | | 21.54 | 21.77 | 21.42 | | |
| 20 | 50 | 24 | | 21.61 | 21.65 | 21.40 | | |
| 20 | 50 | 50 | | 21.60 | 21.49 | 21.43 | | |
| 20 | 100 | 0 | | 21.56 | 21.60 | 21.40 | | |
| 20 | 1 | 0 | 256-QAM | 19.30 | 19.90 | 19.49 | 17.97 | 0.0627 |
| 20 | 1 | 49 | | 19.02 | 19.67 | 19.18 | | |
| 20 | 1 | 99 | | 18.74 | 19.43 | 19.02 | | |
| 20 | 50 | 0 | | 19.05 | 19.72 | 19.22 | | |
| 20 | 50 | 24 | | 18.96 | 19.60 | 19.18 | | |
| 20 | 50 | 50 | | 18.80 | 19.45 | 18.96 | | |
| 20 | 100 | 0 | | 18.91 | 19.56 | 19.12 | | |
| Limit | EIRP < 2W | | | Result | | | Pass | |



| LTE Band 2 Maximum Average Power [dBm] (GT - LC = -1.93 dB) | | | | | | | | |
|---|-----------|-----------|---------|--------|--------|---------|------------|----------|
| BW [MHz] | RB Size | RB Offset | Mod | Lowest | Middle | Highest | EIRP (dBm) | EIRP (W) |
| 15 | 1 | 0 | QPSK | 24.36 | 24.67 | 24.35 | 22.74 | 0.1879 |
| 15 | 1 | 37 | | 24.27 | 24.40 | 24.20 | | |
| 15 | 1 | 74 | | 24.24 | 24.15 | 24.46 | | |
| 15 | 36 | 0 | | 23.32 | 23.69 | 23.29 | | |
| 15 | 36 | 20 | | 23.37 | 23.56 | 23.35 | | |
| 15 | 36 | 39 | | 23.33 | 23.19 | 23.24 | | |
| 15 | 75 | 0 | | 23.49 | 23.55 | 23.32 | | |
| 15 | 1 | 0 | 16-QAM | 23.58 | 24.04 | 23.50 | 22.11 | 0.1626 |
| 15 | 1 | 37 | | 23.77 | 23.65 | 23.47 | | |
| 15 | 1 | 74 | | 23.76 | 23.41 | 23.52 | | |
| 15 | 36 | 0 | | 22.44 | 22.60 | 22.29 | | |
| 15 | 36 | 20 | | 22.56 | 22.53 | 22.27 | | |
| 15 | 36 | 39 | | 22.46 | 22.33 | 22.33 | | |
| 15 | 75 | 0 | | 22.36 | 22.39 | 22.22 | | |
| 15 | 1 | 0 | 64-QAM | 22.25 | 23.09 | 22.55 | 21.16 | 0.1306 |
| 15 | 1 | 37 | | 22.55 | 22.70 | 22.22 | | |
| 15 | 1 | 74 | | 22.58 | 22.41 | 22.56 | | |
| 15 | 36 | 0 | | 21.49 | 21.70 | 21.34 | | |
| 15 | 36 | 20 | | 21.51 | 21.56 | 21.36 | | |
| 15 | 36 | 39 | | 21.57 | 21.31 | 21.41 | | |
| 15 | 75 | 0 | | 21.37 | 21.42 | 21.39 | | |
| 15 | 1 | 0 | 256-QAM | 19.12 | 19.72 | 19.35 | 17.79 | 0.0601 |
| 15 | 1 | 37 | | 18.97 | 19.66 | 19.18 | | |
| 15 | 1 | 74 | | 18.74 | 19.41 | 18.91 | | |
| 15 | 36 | 0 | | 18.99 | 19.53 | 19.02 | | |
| 15 | 36 | 20 | | 18.92 | 19.53 | 19.13 | | |
| 15 | 36 | 39 | | 18.75 | 19.43 | 18.80 | | |
| 15 | 75 | 0 | | 18.87 | 19.55 | 18.99 | | |
| Limit | EIRP < 2W | | | Result | | | Pass | |



| LTE Band 2 Maximum Average Power [dBm] (GT - LC = -1.93 dB) | | | | | | | | |
|---|-----------|-----------|---------|--------|--------|---------|------------|----------|
| BW [MHz] | RB Size | RB Offset | Mod | Lowest | Middle | Highest | EIRP (dBm) | EIRP (W) |
| 10 | 1 | 0 | QPSK | 24.24 | 24.74 | 24.40 | 22.81 | 0.1910 |
| 10 | 1 | 25 | | 24.31 | 24.36 | 24.14 | | |
| 10 | 1 | 49 | | 24.21 | 24.15 | 24.33 | | |
| 10 | 25 | 0 | | 23.34 | 23.57 | 23.27 | | |
| 10 | 25 | 12 | | 23.30 | 23.38 | 23.17 | | |
| 10 | 25 | 25 | | 23.28 | 23.29 | 23.30 | | |
| 10 | 50 | 0 | | 23.50 | 23.48 | 23.27 | | |
| 10 | 1 | 0 | 16-QAM | 23.57 | 24.03 | 23.50 | 22.10 | 0.1622 |
| 10 | 1 | 25 | | 23.70 | 23.74 | 23.35 | | |
| 10 | 1 | 49 | | 23.76 | 23.46 | 23.52 | | |
| 10 | 25 | 0 | | 22.51 | 22.58 | 22.32 | | |
| 10 | 25 | 12 | | 22.46 | 22.59 | 22.30 | | |
| 10 | 25 | 25 | | 22.55 | 22.34 | 22.34 | | |
| 10 | 50 | 0 | | 22.31 | 22.53 | 22.24 | | |
| 10 | 1 | 0 | 64-QAM | 22.34 | 23.10 | 22.59 | 21.17 | 0.1309 |
| 10 | 1 | 25 | | 22.42 | 22.72 | 22.26 | | |
| 10 | 1 | 49 | | 22.60 | 22.40 | 22.49 | | |
| 10 | 25 | 0 | | 21.34 | 21.73 | 21.32 | | |
| 10 | 25 | 12 | | 21.55 | 21.65 | 21.30 | | |
| 10 | 25 | 25 | | 21.42 | 21.37 | 21.43 | | |
| 10 | 50 | 0 | | 21.46 | 21.40 | 21.20 | | |
| 10 | 1 | 0 | 256-QAM | 19.19 | 19.71 | 19.32 | 17.78 | 0.0600 |
| 10 | 1 | 25 | | 18.87 | 19.62 | 19.04 | | |
| 10 | 1 | 49 | | 18.72 | 19.39 | 19.02 | | |
| 10 | 25 | 0 | | 19.01 | 19.67 | 19.13 | | |
| 10 | 25 | 12 | | 18.86 | 19.56 | 19.15 | | |
| 10 | 25 | 25 | | 18.76 | 19.40 | 18.93 | | |
| 10 | 50 | 0 | | 18.90 | 19.46 | 19.06 | | |
| Limit | EIRP < 2W | | | Result | | | Pass | |



| LTE Band 2 Maximum Average Power [dBm] (GT - LC = -1.93 dB) | | | | | | | | |
|---|-----------|-----------|---------|--------|--------|---------|------------|----------|
| BW [MHz] | RB Size | RB Offset | Mod | Lowest | Middle | Highest | EIRP (dBm) | EIRP (W) |
| 5 | 1 | 0 | QPSK | 24.41 | 24.59 | 24.50 | 22.66 | 0.1845 |
| 5 | 1 | 12 | | 24.23 | 24.30 | 24.24 | | |
| 5 | 1 | 24 | | 24.17 | 24.04 | 24.40 | | |
| 5 | 12 | 0 | | 23.47 | 23.60 | 23.37 | | |
| 5 | 12 | 7 | | 23.46 | 23.48 | 23.21 | | |
| 5 | 12 | 13 | | 23.38 | 23.31 | 23.28 | | |
| 5 | 25 | 0 | | 23.49 | 23.36 | 23.37 | | |
| 5 | 1 | 0 | 16-QAM | 23.56 | 24.03 | 23.62 | 22.10 | 0.1622 |
| 5 | 1 | 12 | | 23.76 | 23.59 | 23.47 | | |
| 5 | 1 | 24 | | 23.77 | 23.48 | 23.62 | | |
| 5 | 12 | 0 | | 22.38 | 22.69 | 22.22 | | |
| 5 | 12 | 7 | | 22.39 | 22.45 | 22.35 | | |
| 5 | 12 | 13 | | 22.48 | 22.28 | 22.37 | | |
| 5 | 25 | 0 | | 22.38 | 22.42 | 22.25 | | |
| 5 | 1 | 0 | 64-QAM | 22.31 | 22.99 | 22.57 | 21.06 | 0.1276 |
| 5 | 1 | 12 | | 22.41 | 22.58 | 22.21 | | |
| 5 | 1 | 24 | | 22.62 | 22.44 | 22.57 | | |
| 5 | 12 | 0 | | 21.44 | 21.59 | 21.27 | | |
| 5 | 12 | 7 | | 21.49 | 21.56 | 21.29 | | |
| 5 | 12 | 13 | | 21.60 | 21.49 | 21.43 | | |
| 5 | 25 | 0 | | 21.53 | 21.57 | 21.39 | | |
| 5 | 1 | 0 | 256-QAM | 19.29 | 19.88 | 19.31 | 17.95 | 0.0624 |
| 5 | 1 | 12 | | 18.89 | 19.51 | 19.11 | | |
| 5 | 1 | 24 | | 18.78 | 19.41 | 19.01 | | |
| 5 | 12 | 0 | | 18.94 | 19.54 | 19.02 | | |
| 5 | 12 | 7 | | 18.77 | 19.54 | 19.13 | | |
| 5 | 12 | 13 | | 18.73 | 19.34 | 18.84 | | |
| 5 | 25 | 0 | | 18.84 | 19.56 | 18.92 | | |
| Limit | EIRP < 2W | | | Result | | | Pass | |



| LTE Band 2 Maximum Average Power [dBm] (GT - LC = -1.93 dB) | | | | | | | | |
|---|-----------|-----------|---------|--------|--------|---------|------------|----------|
| BW [MHz] | RB Size | RB Offset | Mod | Lowest | Middle | Highest | EIRP (dBm) | EIRP (W) |
| 3 | 1 | 0 | QPSK | 24.37 | 24.65 | 24.48 | 22.72 | 0.1871 |
| 3 | 1 | 8 | | 24.34 | 24.39 | 24.26 | | |
| 3 | 1 | 14 | | 24.16 | 24.16 | 24.44 | | |
| 3 | 8 | 0 | | 23.40 | 23.66 | 23.30 | | |
| 3 | 8 | 4 | | 23.30 | 23.39 | 23.30 | | |
| 3 | 8 | 7 | | 23.33 | 23.32 | 23.12 | | |
| 3 | 15 | 0 | | 23.32 | 23.45 | 23.42 | | |
| 3 | 1 | 0 | 16-QAM | 23.59 | 24.03 | 23.62 | 22.10 | 0.1622 |
| 3 | 1 | 8 | | 23.79 | 23.63 | 23.28 | | |
| 3 | 1 | 14 | | 23.65 | 23.39 | 23.62 | | |
| 3 | 8 | 0 | | 22.45 | 22.58 | 22.28 | | |
| 3 | 8 | 4 | | 22.45 | 22.45 | 22.33 | | |
| 3 | 8 | 7 | | 22.44 | 22.43 | 22.40 | | |
| 3 | 15 | 0 | | 22.39 | 22.38 | 22.35 | | |
| 3 | 1 | 0 | 64-QAM | 22.21 | 23.06 | 22.63 | 21.13 | 0.1297 |
| 3 | 1 | 8 | | 22.50 | 22.62 | 22.31 | | |
| 3 | 1 | 14 | | 22.56 | 22.35 | 22.49 | | |
| 3 | 8 | 0 | | 21.40 | 21.66 | 21.36 | | |
| 3 | 8 | 4 | | 21.61 | 21.59 | 21.20 | | |
| 3 | 8 | 7 | | 21.58 | 21.39 | 21.41 | | |
| 3 | 15 | 0 | | 21.48 | 21.55 | 21.26 | | |
| 3 | 1 | 0 | 256-QAM | 19.16 | 19.73 | 19.45 | 17.80 | 0.0603 |
| 3 | 1 | 8 | | 18.89 | 19.49 | 19.15 | | |
| 3 | 1 | 14 | | 18.72 | 19.40 | 19.01 | | |
| 3 | 8 | 0 | | 18.87 | 19.60 | 19.18 | | |
| 3 | 8 | 4 | | 18.81 | 19.45 | 19.16 | | |
| 3 | 8 | 7 | | 18.70 | 19.26 | 18.77 | | |
| 3 | 15 | 0 | | 18.73 | 19.54 | 19.03 | | |
| Limit | EIRP < 2W | | | Result | | | Pass | |



| LTE Band 2 Maximum Average Power [dBm] (GT - LC = -1.93 dB) | | | | | | | | |
|---|-----------|-----------|---------|--------|--------|---------|------------|----------|
| BW [MHz] | RB Size | RB Offset | Mod | Lowest | Middle | Highest | EIRP (dBm) | EIRP (W) |
| 1.4 | 1 | 0 | QPSK | 24.22 | 24.65 | 24.52 | 22.73 | 0.1875 |
| 1.4 | 1 | 3 | | 24.27 | 24.40 | 24.12 | | |
| 1.4 | 1 | 5 | | 24.28 | 24.07 | 24.27 | | |
| 1.4 | 3 | 0 | | 24.31 | 24.66 | 24.39 | | |
| 1.4 | 3 | 1 | | 24.37 | 24.28 | 24.15 | | |
| 1.4 | 3 | 3 | | 24.22 | 24.10 | 24.41 | | |
| 1.4 | 6 | 0 | | 23.36 | 23.57 | 23.37 | | |
| 1.4 | 1 | 0 | 16-QAM | 23.31 | 23.52 | 23.24 | 22.06 | 0.1607 |
| 1.4 | 1 | 3 | | 23.44 | 23.29 | 23.21 | | |
| 1.4 | 1 | 5 | | 23.39 | 23.39 | 23.31 | | |
| 1.4 | 3 | 0 | | 23.62 | 23.99 | 23.69 | | |
| 1.4 | 3 | 1 | | 23.76 | 23.67 | 23.27 | | |
| 1.4 | 3 | 3 | | 23.78 | 23.37 | 23.63 | | |
| 1.4 | 6 | 0 | | 22.41 | 22.62 | 22.31 | | |
| 1.4 | 1 | 0 | 64-QAM | 22.38 | 22.47 | 22.24 | 21.10 | 0.1288 |
| 1.4 | 1 | 3 | | 22.57 | 22.29 | 22.21 | | |
| 1.4 | 1 | 5 | | 22.42 | 22.55 | 22.27 | | |
| 1.4 | 3 | 0 | | 22.29 | 23.03 | 22.68 | | |
| 1.4 | 3 | 1 | | 22.48 | 22.71 | 22.19 | | |
| 1.4 | 3 | 3 | | 22.56 | 22.45 | 22.50 | | |
| 1.4 | 6 | 0 | | 21.46 | 21.59 | 21.38 | | |
| 1.4 | 1 | 0 | 256-QAM | 19.12 | 19.81 | 19.29 | 17.88 | 0.0614 |
| 1.4 | 1 | 3 | | 18.88 | 19.53 | 19.17 | | |
| 1.4 | 1 | 5 | | 18.71 | 19.40 | 18.99 | | |
| 1.4 | 3 | 0 | | 19.01 | 19.70 | 19.14 | | |
| 1.4 | 3 | 1 | | 18.92 | 19.43 | 19.08 | | |
| 1.4 | 3 | 3 | | 18.70 | 19.41 | 18.78 | | |
| 1.4 | 6 | 0 | | 18.72 | 19.53 | 19.06 | | |
| Limit | EIRP < 2W | | | Result | | | Pass | |



| LTE Band 25 Maximum Average Power [dBm] (GT - LC = -1.93 dB) | | | | | | | | |
|--|-----------|-----------|---------|--------|--------|---------|------------|----------|
| BW [MHz] | RB Size | RB Offset | Mod | Lowest | Middle | Highest | EIRP (dBm) | EIRP (W) |
| 20 | 1 | 0 | QPSK | 24.38 | 24.77 | 24.46 | 22.84 | 0.1923 |
| 20 | 1 | 49 | | 24.23 | 24.48 | 24.29 | | |
| 20 | 1 | 99 | | 24.24 | 24.13 | 24.28 | | |
| 20 | 50 | 0 | | 23.31 | 23.53 | 23.39 | | |
| 20 | 50 | 24 | | 23.23 | 23.41 | 23.29 | | |
| 20 | 50 | 50 | | 23.27 | 23.25 | 23.20 | | |
| 20 | 100 | 0 | | 23.26 | 23.40 | 23.30 | | |
| 20 | 1 | 0 | 16-QAM | 23.51 | 23.97 | 23.48 | 22.04 | 0.1600 |
| 20 | 1 | 49 | | 23.53 | 23.52 | 23.42 | | |
| 20 | 1 | 99 | | 23.47 | 23.35 | 23.65 | | |
| 20 | 50 | 0 | | 22.25 | 22.56 | 22.19 | | |
| 20 | 50 | 24 | | 22.34 | 22.43 | 22.25 | | |
| 20 | 50 | 50 | | 22.33 | 22.27 | 22.37 | | |
| 20 | 100 | 0 | | 22.28 | 22.38 | 22.25 | | |
| 20 | 1 | 0 | 64-QAM | 22.37 | 22.81 | 22.28 | 20.88 | 0.1225 |
| 20 | 1 | 49 | | 22.55 | 22.66 | 22.28 | | |
| 20 | 1 | 99 | | 22.54 | 22.33 | 22.43 | | |
| 20 | 50 | 0 | | 21.30 | 21.58 | 21.24 | | |
| 20 | 50 | 24 | | 21.37 | 21.44 | 21.30 | | |
| 20 | 50 | 50 | | 21.35 | 21.29 | 21.39 | | |
| 20 | 100 | 0 | | 21.32 | 21.42 | 21.27 | | |
| 20 | 1 | 0 | 256-QAM | 19.46 | 19.82 | 19.41 | 17.89 | 0.0615 |
| 20 | 1 | 49 | | 19.12 | 19.50 | 19.04 | | |
| 20 | 1 | 99 | | 18.89 | 19.32 | 18.85 | | |
| 20 | 50 | 0 | | 19.16 | 19.60 | 19.14 | | |
| 20 | 50 | 24 | | 19.05 | 19.46 | 19.03 | | |
| 20 | 50 | 50 | | 18.90 | 19.33 | 18.83 | | |
| 20 | 100 | 0 | | 19.07 | 19.43 | 18.99 | | |
| Limit | EIRP < 2W | | | Result | | | Pass | |



| LTE Band 25 Maximum Average Power [dBm] (GT - LC = -1.93 dB) | | | | | | | | |
|--|-----------|-----------|---------|--------|--------|---------|------------|----------|
| BW [MHz] | RB Size | RB Offset | Mod | Lowest | Middle | Highest | EIRP (dBm) | EIRP (W) |
| 15 | 1 | 0 | QPSK | 24.32 | 24.68 | 24.42 | 22.75 | 0.1884 |
| 15 | 1 | 37 | | 24.19 | 24.38 | 24.14 | | |
| 15 | 1 | 74 | | 24.11 | 24.03 | 24.08 | | |
| 15 | 36 | 0 | | 23.23 | 23.47 | 23.30 | | |
| 15 | 36 | 20 | | 23.23 | 23.32 | 23.29 | | |
| 15 | 36 | 39 | | 23.08 | 23.18 | 23.20 | | |
| 15 | 75 | 0 | | 23.24 | 23.28 | 23.24 | | |
| 15 | 1 | 0 | 16-QAM | 23.37 | 23.84 | 23.37 | 21.91 | 0.1552 |
| 15 | 1 | 37 | | 23.46 | 23.32 | 23.40 | | |
| 15 | 1 | 74 | | 23.30 | 23.25 | 23.54 | | |
| 15 | 36 | 0 | | 22.11 | 22.52 | 21.99 | | |
| 15 | 36 | 20 | | 22.23 | 22.24 | 22.25 | | |
| 15 | 36 | 39 | | 22.16 | 22.22 | 22.34 | | |
| 15 | 75 | 0 | | 22.14 | 22.30 | 22.08 | | |
| 15 | 1 | 0 | 64-QAM | 22.24 | 22.79 | 22.19 | 20.86 | 0.1219 |
| 15 | 1 | 37 | | 22.35 | 22.65 | 22.19 | | |
| 15 | 1 | 74 | | 22.51 | 22.24 | 22.25 | | |
| 15 | 36 | 0 | | 21.15 | 21.50 | 21.17 | | |
| 15 | 36 | 20 | | 21.25 | 21.25 | 21.30 | | |
| 15 | 36 | 39 | | 21.26 | 21.26 | 21.34 | | |
| 15 | 75 | 0 | | 21.29 | 21.22 | 21.07 | | |
| 15 | 1 | 0 | 256-QAM | 19.37 | 19.67 | 19.28 | 17.74 | 0.0594 |
| 15 | 1 | 37 | | 19.08 | 19.46 | 19.00 | | |
| 15 | 1 | 74 | | 18.83 | 19.19 | 18.76 | | |
| 15 | 36 | 0 | | 19.11 | 19.50 | 19.07 | | |
| 15 | 36 | 20 | | 18.96 | 19.37 | 18.84 | | |
| 15 | 36 | 39 | | 18.80 | 19.23 | 18.76 | | |
| 15 | 75 | 0 | | 18.99 | 19.25 | 18.81 | | |
| Limit | EIRP < 2W | | | Result | | | Pass | |



| LTE Band 25 Maximum Average Power [dBm] (GT - LC = -1.93 dB) | | | | | | | | |
|--|-----------|-----------|---------|--------|--------|---------|------------|----------|
| BW [MHz] | RB Size | RB Offset | Mod | Lowest | Middle | Highest | EIRP (dBm) | EIRP (W) |
| 10 | 1 | 0 | QPSK | 24.37 | 24.75 | 24.38 | 22.82 | 0.1914 |
| 10 | 1 | 25 | | 24.21 | 24.39 | 24.18 | | |
| 10 | 1 | 49 | | 24.04 | 23.97 | 24.13 | | |
| 10 | 25 | 0 | | 23.16 | 23.41 | 23.25 | | |
| 10 | 25 | 12 | | 23.22 | 23.23 | 23.21 | | |
| 10 | 25 | 25 | | 23.20 | 23.23 | 23.09 | | |
| 10 | 50 | 0 | | 23.09 | 23.23 | 23.14 | | |
| 10 | 1 | 0 | 16-QAM | 23.32 | 23.88 | 23.36 | 21.95 | 0.1567 |
| 10 | 1 | 25 | | 23.43 | 23.34 | 23.23 | | |
| 10 | 1 | 49 | | 23.43 | 23.28 | 23.48 | | |
| 10 | 25 | 0 | | 22.09 | 22.50 | 22.05 | | |
| 10 | 25 | 12 | | 22.28 | 22.37 | 22.06 | | |
| 10 | 25 | 25 | | 22.15 | 22.24 | 22.30 | | |
| 10 | 50 | 0 | | 22.23 | 22.19 | 22.18 | | |
| 10 | 1 | 0 | 64-QAM | 22.25 | 22.77 | 22.10 | 20.84 | 0.1213 |
| 10 | 1 | 25 | | 22.43 | 22.63 | 22.26 | | |
| 10 | 1 | 49 | | 22.40 | 22.21 | 22.34 | | |
| 10 | 25 | 0 | | 21.10 | 21.57 | 21.20 | | |
| 10 | 25 | 12 | | 21.27 | 21.34 | 21.15 | | |
| 10 | 25 | 25 | | 21.33 | 21.23 | 21.35 | | |
| 10 | 50 | 0 | | 21.16 | 21.32 | 21.25 | | |
| 10 | 1 | 0 | 256-QAM | 19.35 | 19.78 | 19.21 | 17.85 | 0.0610 |
| 10 | 1 | 25 | | 18.93 | 19.42 | 18.95 | | |
| 10 | 1 | 49 | | 18.73 | 19.26 | 18.83 | | |
| 10 | 25 | 0 | | 19.13 | 19.45 | 19.10 | | |
| 10 | 25 | 12 | | 18.99 | 19.33 | 19.00 | | |
| 10 | 25 | 25 | | 18.86 | 19.14 | 18.72 | | |
| 10 | 50 | 0 | | 19.05 | 19.35 | 18.87 | | |
| Limit | EIRP < 2W | | | Result | | | Pass | |



| LTE Band 25 Maximum Average Power [dBm] (GT - LC = -1.93 dB) | | | | | | | | |
|--|-----------|-----------|---------|--------|--------|---------|------------|----------|
| BW [MHz] | RB Size | RB Offset | Mod | Lowest | Middle | Highest | EIRP (dBm) | EIRP (W) |
| 5 | 1 | 0 | QPSK | 24.30 | 24.63 | 24.37 | 22.70 | 0.1862 |
| 5 | 1 | 12 | | 24.21 | 24.40 | 24.11 | | |
| 5 | 1 | 24 | | 24.14 | 23.96 | 24.08 | | |
| 5 | 12 | 0 | | 23.31 | 23.47 | 23.19 | | |
| 5 | 12 | 7 | | 23.09 | 23.36 | 23.24 | | |
| 5 | 12 | 13 | | 23.15 | 23.09 | 23.05 | | |
| 5 | 25 | 0 | | 23.24 | 23.22 | 23.29 | | |
| 5 | 1 | 0 | 16-QAM | 23.38 | 23.96 | 23.47 | 22.03 | 0.1596 |
| 5 | 1 | 12 | | 23.42 | 23.35 | 23.31 | | |
| 5 | 1 | 24 | | 23.30 | 23.16 | 23.63 | | |
| 5 | 12 | 0 | | 22.22 | 22.45 | 22.03 | | |
| 5 | 12 | 7 | | 22.26 | 22.27 | 22.18 | | |
| 5 | 12 | 13 | | 22.17 | 22.13 | 22.24 | | |
| 5 | 25 | 0 | | 22.16 | 22.23 | 22.21 | | |
| 5 | 1 | 0 | 64-QAM | 22.35 | 22.81 | 22.20 | 20.88 | 0.1225 |
| 5 | 1 | 12 | | 22.54 | 22.57 | 22.14 | | |
| 5 | 1 | 24 | | 22.43 | 22.30 | 22.31 | | |
| 5 | 12 | 0 | | 21.17 | 21.43 | 21.09 | | |
| 5 | 12 | 7 | | 21.36 | 21.44 | 21.27 | | |
| 5 | 12 | 13 | | 21.26 | 21.12 | 21.26 | | |
| 5 | 25 | 0 | | 21.29 | 21.37 | 21.24 | | |
| 5 | 1 | 0 | 256-QAM | 19.36 | 19.63 | 19.34 | 17.70 | 0.0589 |
| 5 | 1 | 12 | | 18.95 | 19.38 | 18.97 | | |
| 5 | 1 | 24 | | 18.83 | 19.32 | 18.70 | | |
| 5 | 12 | 0 | | 19.10 | 19.57 | 19.14 | | |
| 5 | 12 | 7 | | 18.92 | 19.32 | 18.93 | | |
| 5 | 12 | 13 | | 18.73 | 19.14 | 18.77 | | |
| 5 | 25 | 0 | | 19.07 | 19.37 | 18.97 | | |
| Limit | EIRP < 2W | | | Result | | | Pass | |



| LTE Band 25 Maximum Average Power [dBm] (GT - LC = -1.93 dB) | | | | | | | | |
|--|-----------|-----------|---------|--------|--------|---------|------------|----------|
| BW [MHz] | RB Size | RB Offset | Mod | Lowest | Middle | Highest | EIRP (dBm) | EIRP (W) |
| 3 | 1 | 0 | QPSK | 24.25 | 24.61 | 24.29 | 22.68 | 0.1854 |
| 3 | 1 | 8 | | 24.16 | 24.32 | 24.11 | | |
| 3 | 1 | 14 | | 24.19 | 24.12 | 24.20 | | |
| 3 | 8 | 0 | | 23.11 | 23.40 | 23.34 | | |
| 3 | 8 | 4 | | 23.14 | 23.22 | 23.10 | | |
| 3 | 8 | 7 | | 23.13 | 23.08 | 23.20 | | |
| 3 | 15 | 0 | | 23.19 | 23.33 | 23.28 | | |
| 3 | 1 | 0 | 16-QAM | 23.31 | 23.90 | 23.47 | 21.97 | 0.1574 |
| 3 | 1 | 8 | | 23.53 | 23.39 | 23.41 | | |
| 3 | 1 | 14 | | 23.27 | 23.20 | 23.53 | | |
| 3 | 8 | 0 | | 22.07 | 22.49 | 22.05 | | |
| 3 | 8 | 4 | | 22.17 | 22.29 | 22.22 | | |
| 3 | 8 | 7 | | 22.20 | 22.18 | 22.36 | | |
| 3 | 15 | 0 | | 22.27 | 22.20 | 22.11 | | |
| 3 | 1 | 0 | 64-QAM | 22.27 | 22.77 | 22.28 | 20.84 | 0.1213 |
| 3 | 1 | 8 | | 22.42 | 22.59 | 22.18 | | |
| 3 | 1 | 14 | | 22.43 | 22.24 | 22.32 | | |
| 3 | 8 | 0 | | 21.10 | 21.44 | 21.20 | | |
| 3 | 8 | 4 | | 21.26 | 21.38 | 21.18 | | |
| 3 | 8 | 7 | | 21.17 | 21.09 | 21.21 | | |
| 3 | 15 | 0 | | 21.14 | 21.31 | 21.18 | | |
| 3 | 1 | 0 | 256-QAM | 19.36 | 19.80 | 19.26 | 17.87 | 0.0612 |
| 3 | 1 | 8 | | 18.97 | 19.45 | 18.98 | | |
| 3 | 1 | 14 | | 18.75 | 19.14 | 18.70 | | |
| 3 | 8 | 0 | | 19.13 | 19.50 | 19.03 | | |
| 3 | 8 | 4 | | 18.96 | 19.42 | 18.96 | | |
| 3 | 8 | 7 | | 18.79 | 19.23 | 18.79 | | |
| 3 | 15 | 0 | | 18.99 | 19.35 | 18.86 | | |
| Limit | EIRP < 2W | | | Result | | | Pass | |



| LTE Band 25 Maximum Average Power [dBm] (GT - LC = -1.93 dB) | | | | | | | | |
|--|-----------|-----------|---------|--------|--------|---------|------------|----------|
| BW [MHz] | RB Size | RB Offset | Mod | Lowest | Middle | Highest | EIRP (dBm) | EIRP (W) |
| 1.4 | 1 | 0 | QPSK | 24.27 | 24.71 | 24.33 | 22.78 | 0.1897 |
| 1.4 | 1 | 3 | | 24.13 | 24.41 | 24.18 | | |
| 1.4 | 1 | 5 | | 24.23 | 24.01 | 24.08 | | |
| 1.4 | 3 | 0 | | 24.37 | 24.65 | 24.46 | | |
| 1.4 | 3 | 1 | | 24.04 | 24.30 | 24.16 | | |
| 1.4 | 3 | 3 | | 24.21 | 23.96 | 24.12 | | |
| 1.4 | 6 | 0 | | 23.27 | 23.43 | 23.25 | | |
| 1.4 | 1 | 0 | 16-QAM | 23.11 | 23.32 | 23.11 | 21.88 | 0.1542 |
| 1.4 | 1 | 3 | | 23.09 | 23.06 | 23.15 | | |
| 1.4 | 1 | 5 | | 23.07 | 23.29 | 23.23 | | |
| 1.4 | 3 | 0 | | 23.49 | 23.81 | 23.38 | | |
| 1.4 | 3 | 1 | | 23.35 | 23.32 | 23.42 | | |
| 1.4 | 3 | 3 | | 23.31 | 23.20 | 23.60 | | |
| 1.4 | 6 | 0 | | 22.12 | 22.48 | 21.99 | | |
| 1.4 | 1 | 0 | 64-QAM | 22.14 | 22.41 | 22.09 | 20.82 | 0.1208 |
| 1.4 | 1 | 3 | | 22.24 | 22.26 | 22.31 | | |
| 1.4 | 1 | 5 | | 22.18 | 22.18 | 22.07 | | |
| 1.4 | 3 | 0 | | 22.21 | 22.75 | 22.16 | | |
| 1.4 | 3 | 1 | | 22.53 | 22.50 | 22.20 | | |
| 1.4 | 3 | 3 | | 22.44 | 22.18 | 22.40 | | |
| 1.4 | 6 | 0 | | 21.17 | 21.49 | 21.23 | | |
| 1.4 | 1 | 0 | 256-QAM | 19.39 | 19.74 | 19.23 | 17.81 | 0.0604 |
| 1.4 | 1 | 3 | | 19.08 | 19.35 | 19.00 | | |
| 1.4 | 1 | 5 | | 18.70 | 19.30 | 18.84 | | |
| 1.4 | 3 | 0 | | 18.97 | 19.54 | 19.00 | | |
| 1.4 | 3 | 1 | | 19.01 | 19.35 | 18.95 | | |
| 1.4 | 3 | 3 | | 18.84 | 19.30 | 18.73 | | |
| 1.4 | 6 | 0 | | 18.93 | 19.35 | 18.94 | | |
| Limit | EIRP < 2W | | | Result | | | Pass | |



| LTE Band 4 Maximum Average Power [dBm] (GT - LC = -1.88 dB) | | | | | | | | |
|---|-----------|-----------|---------|--------|--------|---------|------------|----------|
| BW [MHz] | RB Size | RB Offset | Mod | Lowest | Middle | Highest | EIRP (dBm) | EIRP (W) |
| 20 | 1 | 0 | QPSK | 24.65 | 24.61 | 24.74 | 22.86 | 0.1932 |
| 20 | 1 | 49 | | 24.59 | 24.54 | 24.59 | | |
| 20 | 1 | 99 | | 24.55 | 24.50 | 24.41 | | |
| 20 | 50 | 0 | | 23.57 | 23.53 | 23.64 | | |
| 20 | 50 | 24 | | 23.54 | 23.53 | 23.58 | | |
| 20 | 50 | 50 | | 23.53 | 23.50 | 23.50 | | |
| 20 | 100 | 0 | | 23.54 | 23.53 | 23.58 | | |
| 20 | 1 | 0 | 16-QAM | 23.71 | 23.68 | 23.92 | 22.04 | 0.1600 |
| 20 | 1 | 49 | | 23.63 | 23.47 | 23.81 | | |
| 20 | 1 | 99 | | 23.72 | 23.59 | 23.64 | | |
| 20 | 50 | 0 | | 22.49 | 22.49 | 22.63 | | |
| 20 | 50 | 24 | | 22.54 | 22.47 | 22.59 | | |
| 20 | 50 | 50 | | 22.57 | 22.47 | 22.49 | | |
| 20 | 100 | 0 | | 22.53 | 22.48 | 22.53 | | |
| 20 | 1 | 0 | 64-QAM | 22.48 | 22.62 | 22.76 | 20.88 | 0.1225 |
| 20 | 1 | 49 | | 22.57 | 22.57 | 22.71 | | |
| 20 | 1 | 99 | | 22.68 | 22.52 | 22.68 | | |
| 20 | 50 | 0 | | 21.52 | 21.51 | 21.67 | | |
| 20 | 50 | 24 | | 21.57 | 21.52 | 21.60 | | |
| 20 | 50 | 50 | | 21.57 | 21.48 | 21.52 | | |
| 20 | 100 | 0 | | 21.54 | 21.49 | 21.54 | | |
| 20 | 1 | 0 | 256-QAM | 19.45 | 19.43 | 19.64 | 17.90 | 0.0617 |
| 20 | 1 | 49 | | 19.51 | 19.53 | 19.70 | | |
| 20 | 1 | 99 | | 19.63 | 19.62 | 19.78 | | |
| 20 | 50 | 0 | | 19.34 | 19.35 | 19.48 | | |
| 20 | 50 | 24 | | 19.37 | 19.44 | 19.58 | | |
| 20 | 50 | 50 | | 19.39 | 19.45 | 19.57 | | |
| 20 | 100 | 0 | | 19.39 | 19.43 | 19.58 | | |
| Limit | EIRP < 1W | | | Result | | | Pass | |



| LTE Band 4 Maximum Average Power [dBm] (GT - LC = -1.88 dB) | | | | | | | | |
|---|-----------|-----------|---------|--------|--------|---------|------------|----------|
| BW [MHz] | RB Size | RB Offset | Mod | Lowest | Middle | Highest | EIRP (dBm) | EIRP (W) |
| 15 | 1 | 0 | QPSK | 24.55 | 24.42 | 24.73 | 22.85 | 0.1928 |
| 15 | 1 | 37 | | 24.42 | 24.45 | 24.58 | | |
| 15 | 1 | 74 | | 24.46 | 24.32 | 24.26 | | |
| 15 | 36 | 0 | | 23.47 | 23.33 | 23.57 | | |
| 15 | 36 | 20 | | 23.48 | 23.40 | 23.39 | | |
| 15 | 36 | 39 | | 23.51 | 23.49 | 23.34 | | |
| 15 | 75 | 0 | | 23.46 | 23.40 | 23.53 | | |
| 15 | 1 | 0 | 16-QAM | 23.63 | 23.64 | 23.77 | 21.89 | 0.1545 |
| 15 | 1 | 37 | | 23.60 | 23.47 | 23.65 | | |
| 15 | 1 | 74 | | 23.60 | 23.52 | 23.62 | | |
| 15 | 36 | 0 | | 22.34 | 22.47 | 22.54 | | |
| 15 | 36 | 20 | | 22.46 | 22.28 | 22.47 | | |
| 15 | 36 | 39 | | 22.49 | 22.28 | 22.47 | | |
| 15 | 75 | 0 | | 22.45 | 22.40 | 22.39 | | |
| 15 | 1 | 0 | 64-QAM | 22.38 | 22.53 | 22.73 | 20.85 | 0.1216 |
| 15 | 1 | 37 | | 22.51 | 22.43 | 22.71 | | |
| 15 | 1 | 74 | | 22.57 | 22.38 | 22.66 | | |
| 15 | 36 | 0 | | 21.52 | 21.42 | 21.56 | | |
| 15 | 36 | 20 | | 21.52 | 21.33 | 21.51 | | |
| 15 | 36 | 39 | | 21.54 | 21.41 | 21.50 | | |
| 15 | 75 | 0 | | 21.38 | 21.44 | 21.47 | | |
| 15 | 1 | 0 | 256-QAM | 19.36 | 19.24 | 19.50 | 17.78 | 0.0600 |
| 15 | 1 | 37 | | 19.31 | 19.44 | 19.66 | | |
| 15 | 1 | 74 | | 19.63 | 19.44 | 19.58 | | |
| 15 | 36 | 0 | | 19.28 | 19.15 | 19.46 | | |
| 15 | 36 | 20 | | 19.23 | 19.44 | 19.50 | | |
| 15 | 36 | 39 | | 19.21 | 19.44 | 19.54 | | |
| 15 | 75 | 0 | | 19.26 | 19.25 | 19.54 | | |
| Limit | EIRP < 1W | | | Result | | | Pass | |



| LTE Band 4 Maximum Average Power [dBm] (GT - LC = -1.88 dB) | | | | | | | | |
|---|-----------|-----------|---------|--------|--------|---------|------------|----------|
| BW [MHz] | RB Size | RB Offset | Mod | Lowest | Middle | Highest | EIRP (dBm) | EIRP (W) |
| 10 | 1 | 0 | QPSK | 24.54 | 24.61 | 24.61 | 22.73 | 0.1875 |
| 10 | 1 | 25 | | 24.40 | 24.42 | 24.58 | | |
| 10 | 1 | 49 | | 24.49 | 24.43 | 24.31 | | |
| 10 | 25 | 0 | | 23.37 | 23.42 | 23.63 | | |
| 10 | 25 | 12 | | 23.36 | 23.42 | 23.53 | | |
| 10 | 25 | 25 | | 23.45 | 23.38 | 23.49 | | |
| 10 | 50 | 0 | | 23.54 | 23.48 | 23.47 | | |
| 10 | 1 | 0 | 16-QAM | 23.63 | 23.65 | 23.87 | 21.99 | 0.1581 |
| 10 | 1 | 25 | | 23.63 | 23.44 | 23.73 | | |
| 10 | 1 | 49 | | 23.72 | 23.42 | 23.56 | | |
| 10 | 25 | 0 | | 22.45 | 22.43 | 22.63 | | |
| 10 | 25 | 12 | | 22.44 | 22.28 | 22.57 | | |
| 10 | 25 | 25 | | 22.40 | 22.33 | 22.35 | | |
| 10 | 50 | 0 | | 22.52 | 22.37 | 22.52 | | |
| 10 | 1 | 0 | 64-QAM | 22.44 | 22.56 | 22.65 | 20.77 | 0.1194 |
| 10 | 1 | 25 | | 22.49 | 22.43 | 22.58 | | |
| 10 | 1 | 49 | | 22.51 | 22.42 | 22.58 | | |
| 10 | 25 | 0 | | 21.39 | 21.38 | 21.58 | | |
| 10 | 25 | 12 | | 21.57 | 21.50 | 21.55 | | |
| 10 | 25 | 25 | | 21.48 | 21.38 | 21.40 | | |
| 10 | 50 | 0 | | 21.47 | 21.31 | 21.44 | | |
| 10 | 1 | 0 | 256-QAM | 19.28 | 19.33 | 19.62 | 17.81 | 0.0604 |
| 10 | 1 | 25 | | 19.32 | 19.34 | 19.63 | | |
| 10 | 1 | 49 | | 19.63 | 19.61 | 19.69 | | |
| 10 | 25 | 0 | | 19.25 | 19.17 | 19.46 | | |
| 10 | 25 | 12 | | 19.35 | 19.41 | 19.43 | | |
| 10 | 25 | 25 | | 19.22 | 19.26 | 19.55 | | |
| 10 | 50 | 0 | | 19.27 | 19.35 | 19.40 | | |
| Limit | EIRP < 1W | | | Result | | | Pass | |



| LTE Band 4 Maximum Average Power [dBm] (GT - LC = -1.88 dB) | | | | | | | | |
|---|-----------|-----------|---------|--------|--------|---------|------------|----------|
| BW [MHz] | RB Size | RB Offset | Mod | Lowest | Middle | Highest | EIRP (dBm) | EIRP (W) |
| 5 | 1 | 0 | QPSK | 24.58 | 24.48 | 24.72 | 22.84 | 0.1923 |
| 5 | 1 | 12 | | 24.58 | 24.53 | 24.41 | | |
| 5 | 1 | 24 | | 24.37 | 24.43 | 24.23 | | |
| 5 | 12 | 0 | | 23.50 | 23.51 | 23.63 | | |
| 5 | 12 | 7 | | 23.35 | 23.43 | 23.48 | | |
| 5 | 12 | 13 | | 23.42 | 23.46 | 23.32 | | |
| 5 | 25 | 0 | | 23.38 | 23.35 | 23.42 | | |
| 5 | 1 | 0 | 16-QAM | 23.69 | 23.54 | 23.77 | 21.89 | 0.1545 |
| 5 | 1 | 12 | | 23.48 | 23.36 | 23.72 | | |
| 5 | 1 | 24 | | 23.54 | 23.55 | 23.53 | | |
| 5 | 12 | 0 | | 22.46 | 22.43 | 22.50 | | |
| 5 | 12 | 7 | | 22.43 | 22.35 | 22.45 | | |
| 5 | 12 | 13 | | 22.46 | 22.47 | 22.29 | | |
| 5 | 25 | 0 | | 22.43 | 22.33 | 22.34 | | |
| 5 | 1 | 0 | 64-QAM | 22.35 | 22.59 | 22.73 | 20.85 | 0.1216 |
| 5 | 1 | 12 | | 22.47 | 22.40 | 22.57 | | |
| 5 | 1 | 24 | | 22.65 | 22.43 | 22.58 | | |
| 5 | 12 | 0 | | 21.44 | 21.38 | 21.56 | | |
| 5 | 12 | 7 | | 21.48 | 21.40 | 21.48 | | |
| 5 | 12 | 13 | | 21.39 | 21.40 | 21.34 | | |
| 5 | 25 | 0 | | 21.49 | 21.38 | 21.37 | | |
| 5 | 1 | 0 | 256-QAM | 19.30 | 19.29 | 19.51 | 17.84 | 0.0608 |
| 5 | 1 | 12 | | 19.42 | 19.37 | 19.62 | | |
| 5 | 1 | 24 | | 19.63 | 19.54 | 19.72 | | |
| 5 | 12 | 0 | | 19.29 | 19.29 | 19.28 | | |
| 5 | 12 | 7 | | 19.29 | 19.39 | 19.44 | | |
| 5 | 12 | 13 | | 19.23 | 19.28 | 19.37 | | |
| 5 | 25 | 0 | | 19.38 | 19.39 | 19.50 | | |
| Limit | EIRP < 1W | | | Result | | | Pass | |



| LTE Band 4 Maximum Average Power [dBm] (GT - LC = -1.88 dB) | | | | | | | | |
|---|-----------|-----------|---------|--------|--------|---------|------------|----------|
| BW [MHz] | RB Size | RB Offset | Mod | Lowest | Middle | Highest | EIRP (dBm) | EIRP (W) |
| 3 | 1 | 0 | QPSK | 24.53 | 24.56 | 24.64 | 22.76 | 0.1888 |
| 3 | 1 | 8 | | 24.52 | 24.50 | 24.56 | | |
| 3 | 1 | 14 | | 24.42 | 24.39 | 24.35 | | |
| 3 | 8 | 0 | | 23.55 | 23.43 | 23.60 | | |
| 3 | 8 | 4 | | 23.39 | 23.38 | 23.41 | | |
| 3 | 8 | 7 | | 23.44 | 23.46 | 23.40 | | |
| 3 | 15 | 0 | | 23.41 | 23.35 | 23.41 | | |
| 3 | 1 | 0 | 16-QAM | 23.55 | 23.54 | 23.87 | 21.99 | 0.1581 |
| 3 | 1 | 8 | | 23.60 | 23.44 | 23.79 | | |
| 3 | 1 | 14 | | 23.60 | 23.58 | 23.54 | | |
| 3 | 8 | 0 | | 22.38 | 22.30 | 22.47 | | |
| 3 | 8 | 4 | | 22.45 | 22.44 | 22.54 | | |
| 3 | 8 | 7 | | 22.57 | 22.46 | 22.30 | | |
| 3 | 15 | 0 | | 22.41 | 22.35 | 22.45 | | |
| 3 | 1 | 0 | 64-QAM | 22.30 | 22.42 | 22.60 | 20.78 | 0.1197 |
| 3 | 1 | 8 | | 22.41 | 22.43 | 22.66 | | |
| 3 | 1 | 14 | | 22.64 | 22.39 | 22.57 | | |
| 3 | 8 | 0 | | 21.47 | 21.46 | 21.63 | | |
| 3 | 8 | 4 | | 21.55 | 21.45 | 21.50 | | |
| 3 | 8 | 7 | | 21.50 | 21.46 | 21.44 | | |
| 3 | 15 | 0 | | 21.52 | 21.45 | 21.44 | | |
| 3 | 1 | 0 | 256-QAM | 19.40 | 19.30 | 19.56 | 17.88 | 0.0614 |
| 3 | 1 | 8 | | 19.48 | 19.47 | 19.67 | | |
| 3 | 1 | 14 | | 19.58 | 19.47 | 19.76 | | |
| 3 | 8 | 0 | | 19.21 | 19.18 | 19.46 | | |
| 3 | 8 | 4 | | 19.20 | 19.42 | 19.57 | | |
| 3 | 8 | 7 | | 19.35 | 19.28 | 19.40 | | |
| 3 | 15 | 0 | | 19.35 | 19.26 | 19.57 | | |
| Limit | EIRP < 1W | | | Result | | | Pass | |



| LTE Band 4 Maximum Average Power [dBm] (GT - LC = -1.88 dB) | | | | | | | | |
|---|-----------|-----------|---------|--------|--------|---------|------------|----------|
| BW [MHz] | RB Size | RB Offset | Mod | Lowest | Middle | Highest | EIRP (dBm) | EIRP (W) |
| 1.4 | 1 | 0 | QPSK | 24.47 | 24.45 | 24.59 | 22.83 | 0.1919 |
| 1.4 | 1 | 3 | | 24.43 | 24.46 | 24.45 | | |
| 1.4 | 1 | 5 | | 24.48 | 24.39 | 24.33 | | |
| 1.4 | 3 | 0 | | 24.57 | 24.44 | 24.71 | | |
| 1.4 | 3 | 1 | | 24.48 | 24.50 | 24.46 | | |
| 1.4 | 3 | 3 | | 24.42 | 24.45 | 24.35 | | |
| 1.4 | 6 | 0 | | 23.45 | 23.52 | 23.51 | | |
| 1.4 | 1 | 0 | 16-QAM | 23.44 | 23.45 | 23.54 | 21.98 | 0.1578 |
| 1.4 | 1 | 3 | | 23.45 | 23.31 | 23.38 | | |
| 1.4 | 1 | 5 | | 23.34 | 23.33 | 23.50 | | |
| 1.4 | 3 | 0 | | 23.52 | 23.54 | 23.86 | | |
| 1.4 | 3 | 1 | | 23.48 | 23.30 | 23.70 | | |
| 1.4 | 3 | 3 | | 23.72 | 23.57 | 23.49 | | |
| 1.4 | 6 | 0 | | 22.31 | 22.42 | 22.45 | | |
| 1.4 | 1 | 0 | 64-QAM | 22.45 | 22.47 | 22.41 | 20.85 | 0.1216 |
| 1.4 | 1 | 3 | | 22.52 | 22.44 | 22.32 | | |
| 1.4 | 1 | 5 | | 22.37 | 22.42 | 22.47 | | |
| 1.4 | 3 | 0 | | 22.35 | 22.51 | 22.73 | | |
| 1.4 | 3 | 1 | | 22.42 | 22.57 | 22.51 | | |
| 1.4 | 3 | 3 | | 22.61 | 22.45 | 22.68 | | |
| 1.4 | 6 | 0 | | 21.34 | 21.49 | 21.54 | | |
| 1.4 | 1 | 0 | 256-QAM | 19.25 | 19.42 | 19.61 | 17.83 | 0.0607 |
| 1.4 | 1 | 3 | | 19.33 | 19.47 | 19.62 | | |
| 1.4 | 1 | 5 | | 19.58 | 19.53 | 19.71 | | |
| 1.4 | 3 | 0 | | 19.26 | 19.19 | 19.42 | | |
| 1.4 | 3 | 1 | | 19.30 | 19.31 | 19.50 | | |
| 1.4 | 3 | 3 | | 19.34 | 19.30 | 19.52 | | |
| 1.4 | 6 | 0 | | 19.33 | 19.43 | 19.48 | | |
| Limit | EIRP < 1W | | | Result | | | Pass | |



| LTE Band 5 Maximum Average Power [dBm] (GT - LC = -5.4 dB) | | | | | | | | |
|--|----------|-----------|---------|--------|--------|---------|-----------|---------|
| BW [MHz] | RB Size | RB Offset | Mod | Lowest | Middle | Highest | ERP (dBm) | ERP (W) |
| 10 | 1 | 0 | QPSK | 24.46 | 24.44 | 24.65 | 17.10 | 0.0513 |
| 10 | 1 | 25 | | 24.37 | 24.28 | 24.62 | | |
| 10 | 1 | 49 | | 24.33 | 24.29 | 24.53 | | |
| 10 | 25 | 0 | | 23.40 | 23.35 | 23.67 | | |
| 10 | 25 | 12 | | 23.35 | 23.31 | 23.69 | | |
| 10 | 25 | 25 | | 23.33 | 23.29 | 23.64 | | |
| 10 | 50 | 0 | | 23.35 | 23.33 | 23.70 | | |
| 10 | 1 | 0 | 16-QAM | 23.67 | 23.71 | 24.08 | 16.53 | 0.0450 |
| 10 | 1 | 25 | | 23.64 | 23.68 | 23.92 | | |
| 10 | 1 | 49 | | 23.74 | 23.64 | 23.84 | | |
| 10 | 25 | 0 | | 22.41 | 22.40 | 22.70 | | |
| 10 | 25 | 12 | | 22.38 | 22.35 | 22.66 | | |
| 10 | 25 | 25 | | 22.37 | 22.32 | 22.64 | | |
| 10 | 50 | 0 | | 22.36 | 22.32 | 22.66 | | |
| 10 | 1 | 0 | 64-QAM | 22.57 | 22.55 | 22.84 | 15.29 | 0.0338 |
| 10 | 1 | 25 | | 22.39 | 22.45 | 22.59 | | |
| 10 | 1 | 49 | | 22.53 | 22.40 | 22.54 | | |
| 10 | 25 | 0 | | 21.39 | 21.38 | 21.69 | | |
| 10 | 25 | 12 | | 21.38 | 21.37 | 21.66 | | |
| 10 | 25 | 25 | | 21.35 | 21.34 | 21.62 | | |
| 10 | 50 | 0 | | 21.39 | 21.34 | 21.69 | | |
| 10 | 1 | 0 | 256-QAM | 19.57 | 19.63 | 19.71 | 12.16 | 0.0164 |
| 10 | 1 | 25 | | 19.25 | 19.37 | 19.35 | | |
| 10 | 1 | 49 | | 19.31 | 19.39 | 19.47 | | |
| 10 | 25 | 0 | | 19.25 | 19.41 | 19.42 | | |
| 10 | 25 | 12 | | 19.21 | 19.32 | 19.32 | | |
| 10 | 25 | 25 | | 19.21 | 19.28 | 19.35 | | |
| 10 | 50 | 0 | | 19.21 | 19.31 | 19.33 | | |
| Limit | ERP < 7W | | | Result | | | Pass | |



| LTE Band 5 Maximum Average Power [dBm] (GT - LC = -5.4 dB) | | | | | | | | |
|--|----------|-----------|---------|--------|--------|---------|-----------|---------|
| BW [MHz] | RB Size | RB Offset | Mod | Lowest | Middle | Highest | ERP (dBm) | ERP (W) |
| 5 | 1 | 0 | QPSK | 24.45 | 24.39 | 24.52 | 16.97 | 0.0498 |
| 5 | 1 | 12 | | 24.25 | 24.23 | 24.43 | | |
| 5 | 1 | 24 | | 24.14 | 24.27 | 24.34 | | |
| 5 | 12 | 0 | | 23.30 | 23.32 | 23.63 | | |
| 5 | 12 | 7 | | 23.24 | 23.30 | 23.49 | | |
| 5 | 12 | 13 | | 23.20 | 23.23 | 23.62 | | |
| 5 | 25 | 0 | | 23.16 | 23.16 | 23.51 | | |
| 5 | 1 | 0 | 16-QAM | 23.48 | 23.56 | 23.98 | 16.43 | 0.0440 |
| 5 | 1 | 12 | | 23.59 | 23.64 | 23.88 | | |
| 5 | 1 | 24 | | 23.66 | 23.52 | 23.78 | | |
| 5 | 12 | 0 | | 22.22 | 22.22 | 22.59 | | |
| 5 | 12 | 7 | | 22.18 | 22.28 | 22.48 | | |
| 5 | 12 | 13 | | 22.24 | 22.28 | 22.62 | | |
| 5 | 25 | 0 | | 22.26 | 22.19 | 22.59 | | |
| 5 | 1 | 0 | 64-QAM | 22.42 | 22.35 | 22.81 | 15.26 | 0.0336 |
| 5 | 1 | 12 | | 22.23 | 22.41 | 22.49 | | |
| 5 | 1 | 24 | | 22.47 | 22.29 | 22.38 | | |
| 5 | 12 | 0 | | 21.36 | 21.38 | 21.49 | | |
| 5 | 12 | 7 | | 21.18 | 21.30 | 21.48 | | |
| 5 | 12 | 13 | | 21.35 | 21.25 | 21.44 | | |
| 5 | 25 | 0 | | 21.34 | 21.30 | 21.61 | | |
| 5 | 1 | 0 | 256-QAM | 19.37 | 19.56 | 19.63 | 12.08 | 0.0161 |
| 5 | 1 | 12 | | 19.05 | 19.25 | 19.31 | | |
| 5 | 1 | 24 | | 19.24 | 19.20 | 19.27 | | |
| 5 | 12 | 0 | | 19.25 | 19.41 | 19.38 | | |
| 5 | 12 | 7 | | 19.17 | 19.17 | 19.22 | | |
| 5 | 12 | 13 | | 19.19 | 19.18 | 19.29 | | |
| 5 | 25 | 0 | | 19.15 | 19.29 | 19.30 | | |
| Limit | ERP < 7W | | | Result | | | Pass | |



| LTE Band 5 Maximum Average Power [dBm] (GT - LC = -5.4 dB) | | | | | | | | |
|--|----------|-----------|---------|--------|--------|---------|-----------|---------|
| BW [MHz] | RB Size | RB Offset | Mod | Lowest | Middle | Highest | ERP (dBm) | ERP (W) |
| 3 | 1 | 0 | QPSK | 24.45 | 24.28 | 24.48 | 16.98 | 0.0499 |
| 3 | 1 | 8 | | 24.36 | 24.24 | 24.53 | | |
| 3 | 1 | 14 | | 24.33 | 24.19 | 24.52 | | |
| 3 | 8 | 0 | | 23.29 | 23.34 | 23.61 | | |
| 3 | 8 | 4 | | 23.35 | 23.28 | 23.56 | | |
| 3 | 8 | 7 | | 23.14 | 23.16 | 23.64 | | |
| 3 | 15 | 0 | | 23.25 | 23.29 | 23.67 | | |
| 3 | 1 | 0 | 16-QAM | 23.50 | 23.53 | 24.04 | 16.49 | 0.0446 |
| 3 | 1 | 8 | | 23.54 | 23.65 | 23.80 | | |
| 3 | 1 | 14 | | 23.74 | 23.46 | 23.64 | | |
| 3 | 8 | 0 | | 22.34 | 22.21 | 22.57 | | |
| 3 | 8 | 4 | | 22.37 | 22.23 | 22.46 | | |
| 3 | 8 | 7 | | 22.29 | 22.20 | 22.50 | | |
| 3 | 15 | 0 | | 22.28 | 22.25 | 22.62 | | |
| 3 | 1 | 0 | 64-QAM | 22.56 | 22.35 | 22.64 | 15.09 | 0.0323 |
| 3 | 1 | 8 | | 22.27 | 22.41 | 22.55 | | |
| 3 | 1 | 14 | | 22.39 | 22.32 | 22.35 | | |
| 3 | 8 | 0 | | 21.29 | 21.34 | 21.54 | | |
| 3 | 8 | 4 | | 21.21 | 21.24 | 21.57 | | |
| 3 | 8 | 7 | | 21.20 | 21.17 | 21.53 | | |
| 3 | 15 | 0 | | 21.26 | 21.32 | 21.56 | | |
| 3 | 1 | 0 | 256-QAM | 19.47 | 19.45 | 19.61 | 12.06 | 0.0161 |
| 3 | 1 | 8 | | 19.19 | 19.22 | 19.22 | | |
| 3 | 1 | 14 | | 19.30 | 19.23 | 19.33 | | |
| 3 | 8 | 0 | | 19.22 | 19.26 | 19.35 | | |
| 3 | 8 | 4 | | 19.17 | 19.12 | 19.13 | | |
| 3 | 8 | 7 | | 19.02 | 19.21 | 19.33 | | |
| 3 | 15 | 0 | | 19.15 | 19.20 | 19.30 | | |
| Limit | ERP < 7W | | | Result | | | Pass | |



| LTE Band 5 Maximum Average Power [dBm] (GT - LC = -5.4 dB) | | | | | | | | |
|--|----------|-----------|---------|--------|--------|---------|-----------|---------|
| BW [MHz] | RB Size | RB Offset | Mod | Lowest | Middle | Highest | ERP (dBm) | ERP (W) |
| 1.4 | 1 | 0 | QPSK | 24.41 | 24.34 | 24.64 | 17.09 | 0.0512 |
| 1.4 | 1 | 3 | | 24.32 | 24.16 | 24.61 | | |
| 1.4 | 1 | 5 | | 24.29 | 24.11 | 24.45 | | |
| 1.4 | 3 | 0 | | 24.33 | 24.40 | 24.52 | | |
| 1.4 | 3 | 1 | | 24.17 | 24.26 | 24.49 | | |
| 1.4 | 3 | 3 | | 24.33 | 24.11 | 24.49 | | |
| 1.4 | 6 | 0 | | 23.37 | 23.21 | 23.52 | | |
| 1.4 | 1 | 0 | 16-QAM | 23.35 | 23.28 | 23.51 | 16.52 | 0.0449 |
| 1.4 | 1 | 3 | | 23.18 | 23.15 | 23.62 | | |
| 1.4 | 1 | 5 | | 23.24 | 23.16 | 23.69 | | |
| 1.4 | 3 | 0 | | 23.55 | 23.71 | 24.07 | | |
| 1.4 | 3 | 1 | | 23.48 | 23.61 | 23.86 | | |
| 1.4 | 3 | 3 | | 23.71 | 23.46 | 23.72 | | |
| 1.4 | 6 | 0 | | 22.23 | 22.29 | 22.58 | | |
| 1.4 | 1 | 0 | 64-QAM | 22.37 | 22.24 | 22.63 | 15.20 | 0.0331 |
| 1.4 | 1 | 3 | | 22.28 | 22.17 | 22.63 | | |
| 1.4 | 1 | 5 | | 22.36 | 22.29 | 22.64 | | |
| 1.4 | 3 | 0 | | 22.41 | 22.38 | 22.75 | | |
| 1.4 | 3 | 1 | | 22.24 | 22.44 | 22.59 | | |
| 1.4 | 3 | 3 | | 22.41 | 22.20 | 22.45 | | |
| 1.4 | 6 | 0 | | 21.34 | 21.19 | 21.52 | | |
| 1.4 | 1 | 0 | 256-QAM | 19.50 | 19.53 | 19.63 | 12.08 | 0.0161 |
| 1.4 | 1 | 3 | | 19.21 | 19.32 | 19.19 | | |
| 1.4 | 1 | 5 | | 19.20 | 19.28 | 19.41 | | |
| 1.4 | 3 | 0 | | 19.05 | 19.25 | 19.37 | | |
| 1.4 | 3 | 1 | | 19.10 | 19.16 | 19.30 | | |
| 1.4 | 3 | 3 | | 19.09 | 19.13 | 19.19 | | |
| 1.4 | 6 | 0 | | 19.08 | 19.21 | 19.31 | | |
| Limit | ERP < 7W | | | Result | | | Pass | |



| LTE Band 7 Maximum Average Power [dBm] (GT - LC = -0.66 dB) | | | | | | | | |
|---|-----------|-----------|---------|--------|--------|---------|------------|----------|
| BW [MHz] | RB Size | RB Offset | Mod | Lowest | Middle | Highest | EIRP (dBm) | EIRP (W) |
| 20 | 1 | 0 | QPSK | 24.58 | 24.63 | 24.91 | 24.25 | 0.2661 |
| 20 | 1 | 49 | | 24.57 | 24.63 | 24.88 | | |
| 20 | 1 | 99 | | 24.56 | 24.54 | 24.82 | | |
| 20 | 50 | 0 | | 23.58 | 23.59 | 23.79 | | |
| 20 | 50 | 24 | | 23.52 | 23.54 | 23.75 | | |
| 20 | 50 | 50 | | 23.49 | 23.58 | 23.74 | | |
| 20 | 100 | 0 | | 23.50 | 23.50 | 23.73 | | |
| 20 | 1 | 0 | 16-QAM | 23.73 | 23.88 | 24.10 | 23.47 | 0.2223 |
| 20 | 1 | 49 | | 23.79 | 23.77 | 24.03 | | |
| 20 | 1 | 99 | | 23.86 | 23.73 | 24.13 | | |
| 20 | 50 | 0 | | 22.47 | 22.54 | 22.75 | | |
| 20 | 50 | 24 | | 22.52 | 22.54 | 22.76 | | |
| 20 | 50 | 50 | | 22.56 | 22.54 | 22.82 | | |
| 20 | 100 | 0 | | 22.49 | 22.49 | 22.74 | | |
| 20 | 1 | 0 | 64-QAM | 22.74 | 22.70 | 22.87 | 22.30 | 0.1698 |
| 20 | 1 | 49 | | 22.82 | 22.70 | 22.95 | | |
| 20 | 1 | 99 | | 22.88 | 22.76 | 22.96 | | |
| 20 | 50 | 0 | | 21.52 | 21.56 | 21.79 | | |
| 20 | 50 | 24 | | 21.59 | 21.59 | 21.79 | | |
| 20 | 50 | 50 | | 21.63 | 21.56 | 21.85 | | |
| 20 | 100 | 0 | | 21.53 | 21.51 | 21.77 | | |
| 20 | 1 | 0 | 256-QAM | 19.92 | 19.72 | 20.06 | 19.40 | 0.0871 |
| 20 | 1 | 49 | | 19.66 | 19.56 | 19.87 | | |
| 20 | 1 | 99 | | 19.62 | 19.47 | 19.79 | | |
| 20 | 50 | 0 | | 19.72 | 19.52 | 19.84 | | |
| 20 | 50 | 24 | | 19.63 | 19.48 | 19.82 | | |
| 20 | 50 | 50 | | 19.55 | 19.41 | 19.67 | | |
| 20 | 100 | 0 | | 19.55 | 19.42 | 19.74 | | |
| Limit | EIRP < 2W | | | Result | | | Pass | |



| LTE Band 7 Maximum Average Power [dBm] (GT - LC = -0.66 dB) | | | | | | | | |
|---|-----------|-----------|---------|--------|--------|---------|------------|----------|
| BW [MHz] | RB Size | RB Offset | Mod | Lowest | Middle | Highest | EIRP (dBm) | EIRP (W) |
| 15 | 1 | 0 | QPSK | 24.40 | 24.57 | 24.75 | 24.13 | 0.2588 |
| 15 | 1 | 37 | | 24.51 | 24.49 | 24.79 | | |
| 15 | 1 | 74 | | 24.54 | 24.49 | 24.65 | | |
| 15 | 36 | 0 | | 23.48 | 23.52 | 23.65 | | |
| 15 | 36 | 20 | | 23.33 | 23.48 | 23.60 | | |
| 15 | 36 | 39 | | 23.48 | 23.56 | 23.67 | | |
| 15 | 75 | 0 | | 23.46 | 23.46 | 23.73 | | |
| 15 | 1 | 0 | 16-QAM | 23.68 | 23.72 | 23.93 | 23.45 | 0.2213 |
| 15 | 1 | 37 | | 23.63 | 23.62 | 23.97 | | |
| 15 | 1 | 74 | | 23.85 | 23.56 | 24.11 | | |
| 15 | 36 | 0 | | 22.43 | 22.52 | 22.69 | | |
| 15 | 36 | 20 | | 22.37 | 22.49 | 22.67 | | |
| 15 | 36 | 39 | | 22.44 | 22.40 | 22.75 | | |
| 15 | 75 | 0 | | 22.40 | 22.33 | 22.57 | | |
| 15 | 1 | 0 | 64-QAM | 22.58 | 22.51 | 22.69 | 22.26 | 0.1683 |
| 15 | 1 | 37 | | 22.66 | 22.51 | 22.84 | | |
| 15 | 1 | 74 | | 22.72 | 22.72 | 22.92 | | |
| 15 | 36 | 0 | | 21.47 | 21.55 | 21.77 | | |
| 15 | 36 | 20 | | 21.58 | 21.43 | 21.74 | | |
| 15 | 36 | 39 | | 21.62 | 21.44 | 21.68 | | |
| 15 | 75 | 0 | | 21.34 | 21.40 | 21.64 | | |
| 15 | 1 | 0 | 256-QAM | 19.83 | 19.70 | 19.90 | 19.24 | 0.0839 |
| 15 | 1 | 37 | | 19.53 | 19.42 | 19.71 | | |
| 15 | 1 | 74 | | 19.46 | 19.44 | 19.79 | | |
| 15 | 36 | 0 | | 19.70 | 19.48 | 19.80 | | |
| 15 | 36 | 20 | | 19.51 | 19.43 | 19.64 | | |
| 15 | 36 | 39 | | 19.36 | 19.41 | 19.67 | | |
| 15 | 75 | 0 | | 19.54 | 19.36 | 19.61 | | |
| Limit | EIRP < 2W | | | Result | | | Pass | |



| LTE Band 7 Maximum Average Power [dBm] (GT - LC = -0.66 dB) | | | | | | | | |
|---|-----------|-----------|---------|--------|--------|---------|------------|----------|
| BW [MHz] | RB Size | RB Offset | Mod | Lowest | Middle | Highest | EIRP (dBm) | EIRP (W) |
| 10 | 1 | 0 | QPSK | 24.54 | 24.62 | 24.71 | 24.12 | 0.2582 |
| 10 | 1 | 25 | | 24.50 | 24.59 | 24.75 | | |
| 10 | 1 | 49 | | 24.37 | 24.49 | 24.78 | | |
| 10 | 25 | 0 | | 23.51 | 23.55 | 23.75 | | |
| 10 | 25 | 12 | | 23.42 | 23.53 | 23.60 | | |
| 10 | 25 | 25 | | 23.29 | 23.55 | 23.70 | | |
| 10 | 50 | 0 | | 23.46 | 23.47 | 23.56 | | |
| 10 | 1 | 0 | 16-QAM | 23.54 | 23.68 | 23.92 | 23.46 | 0.2218 |
| 10 | 1 | 25 | | 23.78 | 23.65 | 23.85 | | |
| 10 | 1 | 49 | | 23.73 | 23.60 | 24.12 | | |
| 10 | 25 | 0 | | 22.28 | 22.47 | 22.64 | | |
| 10 | 25 | 12 | | 22.49 | 22.43 | 22.71 | | |
| 10 | 25 | 25 | | 22.44 | 22.36 | 22.81 | | |
| 10 | 50 | 0 | | 22.48 | 22.33 | 22.57 | | |
| 10 | 1 | 0 | 64-QAM | 22.71 | 22.51 | 22.72 | 22.23 | 0.1671 |
| 10 | 1 | 25 | | 22.82 | 22.67 | 22.89 | | |
| 10 | 1 | 49 | | 22.77 | 22.75 | 22.78 | | |
| 10 | 25 | 0 | | 21.33 | 21.36 | 21.69 | | |
| 10 | 25 | 12 | | 21.41 | 21.56 | 21.77 | | |
| 10 | 25 | 25 | | 21.57 | 21.46 | 21.74 | | |
| 10 | 50 | 0 | | 21.38 | 21.34 | 21.65 | | |
| 10 | 1 | 0 | 256-QAM | 19.76 | 19.68 | 19.92 | 19.26 | 0.0843 |
| 10 | 1 | 25 | | 19.64 | 19.41 | 19.77 | | |
| 10 | 1 | 49 | | 19.62 | 19.28 | 19.59 | | |
| 10 | 25 | 0 | | 19.57 | 19.49 | 19.66 | | |
| 10 | 25 | 12 | | 19.60 | 19.44 | 19.69 | | |
| 10 | 25 | 25 | | 19.41 | 19.30 | 19.47 | | |
| 10 | 50 | 0 | | 19.36 | 19.34 | 19.58 | | |
| Limit | EIRP < 2W | | | Result | | | Pass | |



| LTE Band 7 Maximum Average Power [dBm] (GT - LC = -0.66 dB) | | | | | | | | |
|---|-----------|-----------|---------|--------|--------|---------|------------|----------|
| BW [MHz] | RB Size | RB Offset | Mod | Lowest | Middle | Highest | EIRP (dBm) | EIRP (W) |
| 5 | 1 | 0 | QPSK | 24.55 | 24.52 | 24.74 | 24.16 | 0.2606 |
| 5 | 1 | 12 | | 24.39 | 24.46 | 24.78 | | |
| 5 | 1 | 24 | | 24.52 | 24.52 | 24.82 | | |
| 5 | 12 | 0 | | 23.57 | 23.57 | 23.62 | | |
| 5 | 12 | 7 | | 23.49 | 23.38 | 23.72 | | |
| 5 | 12 | 13 | | 23.48 | 23.57 | 23.73 | | |
| 5 | 25 | 0 | | 23.44 | 23.45 | 23.73 | | |
| 5 | 1 | 0 | 16-QAM | 23.55 | 23.84 | 23.90 | 23.29 | 0.2133 |
| 5 | 1 | 12 | | 23.68 | 23.72 | 23.95 | | |
| 5 | 1 | 24 | | 23.79 | 23.73 | 23.93 | | |
| 5 | 12 | 0 | | 22.35 | 22.54 | 22.65 | | |
| 5 | 12 | 7 | | 22.41 | 22.51 | 22.70 | | |
| 5 | 12 | 13 | | 22.54 | 22.49 | 22.63 | | |
| 5 | 25 | 0 | | 22.41 | 22.47 | 22.73 | | |
| 5 | 1 | 0 | 64-QAM | 22.71 | 22.66 | 22.69 | 22.29 | 0.1694 |
| 5 | 1 | 12 | | 22.70 | 22.58 | 22.95 | | |
| 5 | 1 | 24 | | 22.79 | 22.70 | 22.93 | | |
| 5 | 12 | 0 | | 21.34 | 21.41 | 21.74 | | |
| 5 | 12 | 7 | | 21.42 | 21.56 | 21.69 | | |
| 5 | 12 | 13 | | 21.62 | 21.50 | 21.71 | | |
| 5 | 25 | 0 | | 21.38 | 21.32 | 21.70 | | |
| 5 | 1 | 0 | 256-QAM | 19.78 | 19.70 | 20.05 | 19.39 | 0.0869 |
| 5 | 1 | 12 | | 19.49 | 19.40 | 19.82 | | |
| 5 | 1 | 24 | | 19.45 | 19.27 | 19.77 | | |
| 5 | 12 | 0 | | 19.69 | 19.39 | 19.77 | | |
| 5 | 12 | 7 | | 19.51 | 19.45 | 19.66 | | |
| 5 | 12 | 13 | | 19.55 | 19.26 | 19.50 | | |
| 5 | 25 | 0 | | 19.37 | 19.33 | 19.57 | | |
| Limit | EIRP < 2W | | | Result | | | Pass | |



| LTE Band 12 Maximum Average Power [dBm] (GT - LC = -5.6 dB) | | | | | | | | |
|---|----------|-----------|---------|--------|--------|---------|-----------|---------|
| BW [MHz] | RB Size | RB Offset | Mod | Lowest | Middle | Highest | ERP (dBm) | ERP (W) |
| 10 | 1 | 0 | QPSK | 24.43 | 24.53 | 24.43 | 16.78 | 0.0476 |
| 10 | 1 | 25 | | 24.36 | 24.49 | 24.33 | | |
| 10 | 1 | 49 | | 24.42 | 24.51 | 24.38 | | |
| 10 | 25 | 0 | | 23.47 | 23.52 | 23.42 | | |
| 10 | 25 | 12 | | 23.39 | 23.52 | 23.41 | | |
| 10 | 25 | 25 | | 23.45 | 23.50 | 23.40 | | |
| 10 | 50 | 0 | | 23.44 | 23.52 | 23.45 | | |
| 10 | 1 | 0 | 16-QAM | 23.72 | 23.69 | 23.63 | 16.17 | 0.0414 |
| 10 | 1 | 25 | | 23.66 | 23.77 | 23.86 | | |
| 10 | 1 | 49 | | 23.78 | 23.92 | 23.59 | | |
| 10 | 25 | 0 | | 22.43 | 22.52 | 22.42 | | |
| 10 | 25 | 12 | | 22.43 | 22.52 | 22.41 | | |
| 10 | 25 | 25 | | 22.45 | 22.56 | 22.44 | | |
| 10 | 50 | 0 | | 22.39 | 22.51 | 22.41 | | |
| 10 | 1 | 0 | 64-QAM | 22.72 | 22.65 | 22.57 | 15.08 | 0.0322 |
| 10 | 1 | 25 | | 22.48 | 22.59 | 22.63 | | |
| 10 | 1 | 49 | | 22.70 | 22.83 | 22.48 | | |
| 10 | 25 | 0 | | 21.40 | 21.48 | 21.39 | | |
| 10 | 25 | 12 | | 21.40 | 21.52 | 21.40 | | |
| 10 | 25 | 25 | | 21.44 | 21.55 | 21.42 | | |
| 10 | 50 | 0 | | 21.40 | 21.51 | 21.42 | | |
| 10 | 1 | 0 | 256-QAM | 19.78 | 19.82 | 19.75 | 12.07 | 0.0161 |
| 10 | 1 | 25 | | 19.44 | 19.55 | 19.46 | | |
| 10 | 1 | 49 | | 19.53 | 19.62 | 19.54 | | |
| 10 | 25 | 0 | | 19.53 | 19.60 | 19.51 | | |
| 10 | 25 | 12 | | 19.40 | 19.49 | 19.41 | | |
| 10 | 25 | 25 | | 19.36 | 19.50 | 19.35 | | |
| 10 | 50 | 0 | | 19.41 | 19.54 | 19.41 | | |
| Limit | ERP < 3W | | | Result | | | Pass | |



| LTE Band 12 Maximum Average Power [dBm] (GT - LC = -5.6 dB) | | | | | | | | |
|---|----------|-----------|---------|--------|--------|---------|-----------|---------|
| BW [MHz] | RB Size | RB Offset | Mod | Lowest | Middle | Highest | ERP (dBm) | ERP (W) |
| 5 | 1 | 0 | QPSK | 24.43 | 24.33 | 24.30 | 16.73 | 0.0471 |
| 5 | 1 | 12 | | 24.34 | 24.48 | 24.17 | | |
| 5 | 1 | 24 | | 24.30 | 24.37 | 24.36 | | |
| 5 | 12 | 0 | | 23.43 | 23.45 | 23.42 | | |
| 5 | 12 | 7 | | 23.19 | 23.47 | 23.32 | | |
| 5 | 12 | 13 | | 23.43 | 23.40 | 23.33 | | |
| 5 | 25 | 0 | | 23.37 | 23.35 | 23.31 | | |
| 5 | 1 | 0 | 16-QAM | 23.62 | 23.53 | 23.60 | 16.02 | 0.0400 |
| 5 | 1 | 12 | | 23.56 | 23.74 | 23.74 | | |
| 5 | 1 | 24 | | 23.66 | 23.77 | 23.48 | | |
| 5 | 12 | 0 | | 22.29 | 22.33 | 22.22 | | |
| 5 | 12 | 7 | | 22.26 | 22.36 | 22.35 | | |
| 5 | 12 | 13 | | 22.27 | 22.46 | 22.32 | | |
| 5 | 25 | 0 | | 22.21 | 22.36 | 22.37 | | |
| 5 | 1 | 0 | 64-QAM | 22.65 | 22.52 | 22.57 | 14.90 | 0.0309 |
| 5 | 1 | 12 | | 22.42 | 22.39 | 22.55 | | |
| 5 | 1 | 24 | | 22.64 | 22.63 | 22.48 | | |
| 5 | 12 | 0 | | 21.38 | 21.28 | 21.21 | | |
| 5 | 12 | 7 | | 21.23 | 21.33 | 21.25 | | |
| 5 | 12 | 13 | | 21.40 | 21.42 | 21.42 | | |
| 5 | 25 | 0 | | 21.22 | 21.51 | 21.27 | | |
| 5 | 1 | 0 | 256-QAM | 19.77 | 19.67 | 19.72 | 12.02 | 0.0159 |
| 5 | 1 | 12 | | 19.31 | 19.40 | 19.32 | | |
| 5 | 1 | 24 | | 19.53 | 19.43 | 19.49 | | |
| 5 | 12 | 0 | | 19.51 | 19.46 | 19.33 | | |
| 5 | 12 | 7 | | 19.29 | 19.41 | 19.27 | | |
| 5 | 12 | 13 | | 19.27 | 19.36 | 19.23 | | |
| 5 | 25 | 0 | | 19.41 | 19.50 | 19.38 | | |
| Limit | ERP < 3W | | | Result | | | Pass | |



| LTE Band 12 Maximum Average Power [dBm] (GT - LC = -5.6 dB) | | | | | | | | |
|---|----------|-----------|---------|--------|--------|---------|-----------|---------|
| BW [MHz] | RB Size | RB Offset | Mod | Lowest | Middle | Highest | ERP (dBm) | ERP (W) |
| 3 | 1 | 0 | QPSK | 24.39 | 24.38 | 24.30 | 16.73 | 0.0471 |
| 3 | 1 | 8 | | 24.35 | 24.38 | 24.27 | | |
| 3 | 1 | 14 | | 24.38 | 24.48 | 24.29 | | |
| 3 | 8 | 0 | | 23.37 | 23.36 | 23.22 | | |
| 3 | 8 | 4 | | 23.33 | 23.36 | 23.31 | | |
| 3 | 8 | 7 | | 23.27 | 23.42 | 23.25 | | |
| 3 | 15 | 0 | | 23.25 | 23.44 | 23.29 | | |
| 3 | 1 | 0 | 16-QAM | 23.57 | 23.49 | 23.51 | 16.06 | 0.0404 |
| 3 | 1 | 8 | | 23.55 | 23.59 | 23.81 | | |
| 3 | 1 | 14 | | 23.73 | 23.74 | 23.51 | | |
| 3 | 8 | 0 | | 22.34 | 22.47 | 22.38 | | |
| 3 | 8 | 4 | | 22.43 | 22.37 | 22.38 | | |
| 3 | 8 | 7 | | 22.25 | 22.36 | 22.34 | | |
| 3 | 15 | 0 | | 22.33 | 22.47 | 22.22 | | |
| 3 | 1 | 0 | 64-QAM | 22.60 | 22.61 | 22.46 | 14.89 | 0.0308 |
| 3 | 1 | 8 | | 22.30 | 22.42 | 22.56 | | |
| 3 | 1 | 14 | | 22.62 | 22.64 | 22.31 | | |
| 3 | 8 | 0 | | 21.31 | 21.39 | 21.28 | | |
| 3 | 8 | 4 | | 21.27 | 21.48 | 21.24 | | |
| 3 | 8 | 7 | | 21.38 | 21.44 | 21.25 | | |
| 3 | 15 | 0 | | 21.20 | 21.32 | 21.33 | | |
| 3 | 1 | 0 | 256-QAM | 19.59 | 19.68 | 19.72 | 11.97 | 0.0157 |
| 3 | 1 | 8 | | 19.44 | 19.43 | 19.26 | | |
| 3 | 1 | 14 | | 19.45 | 19.53 | 19.45 | | |
| 3 | 8 | 0 | | 19.48 | 19.57 | 19.43 | | |
| 3 | 8 | 4 | | 19.29 | 19.41 | 19.28 | | |
| 3 | 8 | 7 | | 19.22 | 19.44 | 19.17 | | |
| 3 | 15 | 0 | | 19.23 | 19.45 | 19.30 | | |
| Limit | ERP < 3W | | | Result | | | Pass | |



| LTE Band 12 Maximum Average Power [dBm] (GT - LC = -5.6 dB) | | | | | | | | |
|---|----------|-----------|---------|--------|--------|---------|-----------|---------|
| BW [MHz] | RB Size | RB Offset | Mod | Lowest | Middle | Highest | ERP (dBm) | ERP (W) |
| 1.4 | 1 | 0 | QPSK | 24.36 | 24.35 | 24.26 | 16.75 | 0.0473 |
| 1.4 | 1 | 3 | | 24.24 | 24.49 | 24.33 | | |
| 1.4 | 1 | 5 | | 24.38 | 24.50 | 24.22 | | |
| 1.4 | 3 | 0 | | 24.37 | 24.36 | 24.38 | | |
| 1.4 | 3 | 1 | | 24.30 | 24.29 | 24.33 | | |
| 1.4 | 3 | 3 | | 24.38 | 24.43 | 24.22 | | |
| 1.4 | 6 | 0 | | 23.27 | 23.49 | 23.36 | | |
| 1.4 | 1 | 0 | 16-QAM | 23.24 | 23.46 | 23.21 | 16.11 | 0.0408 |
| 1.4 | 1 | 3 | | 23.35 | 23.32 | 23.39 | | |
| 1.4 | 1 | 5 | | 23.25 | 23.44 | 23.29 | | |
| 1.4 | 3 | 0 | | 23.65 | 23.49 | 23.43 | | |
| 1.4 | 3 | 1 | | 23.53 | 23.59 | 23.86 | | |
| 1.4 | 3 | 3 | | 23.74 | 23.79 | 23.41 | | |
| 1.4 | 6 | 0 | | 22.37 | 22.47 | 22.32 | | |
| 1.4 | 1 | 0 | 64-QAM | 22.34 | 22.43 | 22.31 | 15.03 | 0.0318 |
| 1.4 | 1 | 3 | | 22.32 | 22.49 | 22.27 | | |
| 1.4 | 1 | 5 | | 22.37 | 22.46 | 22.22 | | |
| 1.4 | 3 | 0 | | 22.53 | 22.58 | 22.50 | | |
| 1.4 | 3 | 1 | | 22.37 | 22.45 | 22.56 | | |
| 1.4 | 3 | 3 | | 22.64 | 22.78 | 22.38 | | |
| 1.4 | 6 | 0 | | 21.21 | 21.44 | 21.26 | | |
| 1.4 | 1 | 0 | 256-QAM | 19.71 | 19.72 | 19.74 | 11.99 | 0.0158 |
| 1.4 | 1 | 3 | | 19.26 | 19.51 | 19.46 | | |
| 1.4 | 1 | 5 | | 19.46 | 19.54 | 19.37 | | |
| 1.4 | 3 | 0 | | 19.40 | 19.56 | 19.33 | | |
| 1.4 | 3 | 1 | | 19.37 | 19.31 | 19.27 | | |
| 1.4 | 3 | 3 | | 19.31 | 19.37 | 19.21 | | |
| 1.4 | 6 | 0 | | 19.24 | 19.53 | 19.21 | | |
| Limit | ERP < 3W | | | Result | | | Pass | |



| LTE Band 13 Maximum Average Power [dBm] (GT - LC = -5.36 dB) | | | | | | | | |
|--|----------|-----------|---------|--------|--------|---------|-----------|---------|
| BW [MHz] | RB Size | RB Offset | Mod | Lowest | Middle | Highest | ERP (dBm) | ERP (W) |
| 10 | 1 | 0 | QPSK | | 24.32 | | 16.81 | 0.0480 |
| 10 | 1 | 25 | | | 24.21 | | | |
| 10 | 1 | 49 | | | 24.28 | | | |
| 10 | 25 | 0 | | | 23.37 | | | |
| 10 | 25 | 12 | | | 23.35 | | | |
| 10 | 25 | 25 | | | 23.35 | | | |
| 10 | 50 | 0 | | | 23.42 | | | |
| 10 | 1 | 0 | 16-QAM | | 23.48 | | 16.09 | 0.0406 |
| 10 | 1 | 25 | | | 23.56 | | | |
| 10 | 1 | 49 | | | 23.60 | | | |
| 10 | 25 | 0 | | | 22.34 | | | |
| 10 | 25 | 12 | | | 22.34 | | | |
| 10 | 25 | 25 | | | 22.32 | | | |
| 10 | 50 | 0 | | | 22.38 | | | |
| 10 | 1 | 0 | 64-QAM | | 22.52 | | 15.12 | 0.0325 |
| 10 | 1 | 25 | | | 22.59 | | | |
| 10 | 1 | 49 | | | 22.63 | | | |
| 10 | 25 | 0 | | | 21.36 | | | |
| 10 | 25 | 12 | | | 21.36 | | | |
| 10 | 25 | 25 | | | 21.34 | | | |
| 10 | 50 | 0 | | | 21.36 | | | |
| 10 | 1 | 0 | 256-QAM | | 19.67 | | 12.16 | 0.0164 |
| 10 | 1 | 25 | | | 19.38 | | | |
| 10 | 1 | 49 | | | 19.45 | | | |
| 10 | 25 | 0 | | | 19.46 | | | |
| 10 | 25 | 12 | | | 19.35 | | | |
| 10 | 25 | 25 | | | 19.34 | | | |
| 10 | 50 | 0 | | | 19.36 | | | |
| Limit | ERP < 3W | | | Result | | | Pass | |



| LTE Band 13 Maximum Average Power [dBm] (GT - LC = -5.36 dB) | | | | | | | | |
|--|----------|-----------|---------|--------|--------|---------|-----------|---------|
| BW [MHz] | RB Size | RB Offset | Mod | Lowest | Middle | Highest | ERP (dBm) | ERP (W) |
| 5 | 1 | 0 | QPSK | 24.30 | 24.16 | 24.12 | 16.79 | 0.0478 |
| 5 | 1 | 12 | | 24.13 | 24.06 | 24.02 | | |
| 5 | 1 | 24 | | 24.23 | 24.16 | 24.10 | | |
| 5 | 12 | 0 | | 23.26 | 23.34 | 23.31 | | |
| 5 | 12 | 7 | | 23.21 | 23.24 | 23.17 | | |
| 5 | 12 | 13 | | 23.34 | 23.25 | 23.18 | | |
| 5 | 25 | 0 | | 23.42 | 23.34 | 23.32 | | |
| 5 | 1 | 0 | 16-QAM | 23.35 | 23.28 | 23.43 | 16.09 | 0.0406 |
| 5 | 1 | 12 | | 23.44 | 23.50 | 23.40 | | |
| 5 | 1 | 24 | | 23.60 | 23.54 | 23.43 | | |
| 5 | 12 | 0 | | 22.27 | 22.22 | 22.27 | | |
| 5 | 12 | 7 | | 22.25 | 22.29 | 22.32 | | |
| 5 | 12 | 13 | | 22.12 | 22.14 | 22.18 | | |
| 5 | 25 | 0 | | 22.19 | 22.22 | 22.33 | | |
| 5 | 1 | 0 | 64-QAM | 22.39 | 22.49 | 22.48 | 15.11 | 0.0324 |
| 5 | 1 | 12 | | 22.48 | 22.44 | 22.51 | | |
| 5 | 1 | 24 | | 22.55 | 22.62 | 22.59 | | |
| 5 | 12 | 0 | | 21.36 | 21.36 | 21.31 | | |
| 5 | 12 | 7 | | 21.32 | 21.20 | 21.34 | | |
| 5 | 12 | 13 | | 21.24 | 21.21 | 21.30 | | |
| 5 | 25 | 0 | | 21.18 | 21.27 | 21.32 | | |
| 5 | 1 | 0 | 256-QAM | 19.64 | 19.51 | 19.59 | 12.13 | 0.0163 |
| 5 | 1 | 12 | | 19.30 | 19.28 | 19.30 | | |
| 5 | 1 | 24 | | 19.29 | 19.26 | 19.31 | | |
| 5 | 12 | 0 | | 19.43 | 19.30 | 19.43 | | |
| 5 | 12 | 7 | | 19.21 | 19.15 | 19.22 | | |
| 5 | 12 | 13 | | 19.23 | 19.20 | 19.14 | | |
| 5 | 25 | 0 | | 19.33 | 19.36 | 19.30 | | |
| Limit | ERP < 3W | | | Result | | | Pass | |



| LTE Band 17 Maximum Average Power [dBm] (GT - LC = -5.6 dB) | | | | | | | | |
|---|----------|-----------|---------|--------|--------|---------|-----------|---------|
| BW [MHz] | RB Size | RB Offset | Mod | Lowest | Middle | Highest | ERP (dBm) | ERP (W) |
| 10 | 1 | 0 | QPSK | 24.37 | 24.32 | 24.36 | 16.62 | 0.0459 |
| 10 | 1 | 25 | | 24.27 | 24.26 | 24.22 | | |
| 10 | 1 | 49 | | 24.32 | 24.30 | 24.30 | | |
| 10 | 25 | 0 | | 23.37 | 23.34 | 23.32 | | |
| 10 | 25 | 12 | | 23.35 | 23.33 | 23.31 | | |
| 10 | 25 | 25 | | 23.35 | 23.33 | 23.36 | | |
| 10 | 50 | 0 | | 23.37 | 23.36 | 23.36 | | |
| 10 | 1 | 0 | 16-QAM | 23.56 | 23.54 | 23.58 | 15.94 | 0.0393 |
| 10 | 1 | 25 | | 23.68 | 23.69 | 23.69 | | |
| 10 | 1 | 49 | | 23.64 | 23.62 | 23.53 | | |
| 10 | 25 | 0 | | 22.35 | 22.35 | 22.36 | | |
| 10 | 25 | 12 | | 22.38 | 22.34 | 22.36 | | |
| 10 | 25 | 25 | | 22.40 | 22.37 | 22.34 | | |
| 10 | 50 | 0 | | 22.32 | 22.33 | 22.31 | | |
| 10 | 1 | 0 | 64-QAM | 22.44 | 22.44 | 22.43 | 14.88 | 0.0308 |
| 10 | 1 | 25 | | 22.54 | 22.57 | 22.47 | | |
| 10 | 1 | 49 | | 22.63 | 22.51 | 22.41 | | |
| 10 | 25 | 0 | | 21.33 | 21.34 | 21.31 | | |
| 10 | 25 | 12 | | 21.36 | 21.34 | 21.34 | | |
| 10 | 25 | 25 | | 21.37 | 21.38 | 21.33 | | |
| 10 | 50 | 0 | | 21.37 | 21.36 | 21.36 | | |
| 10 | 1 | 0 | 256-QAM | 19.71 | 19.66 | 19.54 | 11.96 | 0.0157 |
| 10 | 1 | 25 | | 19.37 | 19.41 | 19.29 | | |
| 10 | 1 | 49 | | 19.36 | 19.39 | 19.18 | | |
| 10 | 25 | 0 | | 19.48 | 19.43 | 19.26 | | |
| 10 | 25 | 12 | | 19.32 | 19.34 | 19.15 | | |
| 10 | 25 | 25 | | 19.35 | 19.36 | 19.15 | | |
| 10 | 50 | 0 | | 19.41 | 19.36 | 19.22 | | |
| Limit | ERP < 3W | | | Result | | | Pass | |



| LTE Band 17 Maximum Average Power [dBm] (GT - LC = -5.6 dB) | | | | | | | | |
|---|----------|-----------|---------|--------|--------|---------|-----------|---------|
| BW [MHz] | RB Size | RB Offset | Mod | Lowest | Middle | Highest | ERP (dBm) | ERP (W) |
| 5 | 1 | 0 | QPSK | 24.25 | 24.12 | 24.26 | 16.54 | 0.0451 |
| 5 | 1 | 12 | | 24.22 | 24.16 | 24.03 | | |
| 5 | 1 | 24 | | 24.16 | 24.10 | 24.29 | | |
| 5 | 12 | 0 | | 23.28 | 23.28 | 23.26 | | |
| 5 | 12 | 7 | | 23.35 | 23.29 | 23.22 | | |
| 5 | 12 | 13 | | 23.23 | 23.30 | 23.22 | | |
| 5 | 25 | 0 | | 23.27 | 23.26 | 23.20 | | |
| 5 | 1 | 0 | 16-QAM | 23.44 | 23.34 | 23.38 | 15.92 | 0.0391 |
| 5 | 1 | 12 | | 23.48 | 23.67 | 23.56 | | |
| 5 | 1 | 24 | | 23.59 | 23.55 | 23.51 | | |
| 5 | 12 | 0 | | 22.17 | 22.33 | 22.29 | | |
| 5 | 12 | 7 | | 22.37 | 22.28 | 22.36 | | |
| 5 | 12 | 13 | | 22.39 | 22.25 | 22.30 | | |
| 5 | 25 | 0 | | 22.16 | 22.20 | 22.29 | | |
| 5 | 1 | 0 | 64-QAM | 22.32 | 22.41 | 22.30 | 14.79 | 0.0301 |
| 5 | 1 | 12 | | 22.54 | 22.49 | 22.31 | | |
| 5 | 1 | 24 | | 22.51 | 22.33 | 22.34 | | |
| 5 | 12 | 0 | | 21.29 | 21.21 | 21.18 | | |
| 5 | 12 | 7 | | 21.31 | 21.20 | 21.24 | | |
| 5 | 12 | 13 | | 21.37 | 21.33 | 21.26 | | |
| 5 | 25 | 0 | | 21.18 | 21.32 | 21.19 | | |
| 5 | 1 | 0 | 256-QAM | 19.68 | 19.49 | 19.49 | 11.93 | 0.0156 |
| 5 | 1 | 12 | | 19.26 | 19.33 | 19.23 | | |
| 5 | 1 | 24 | | 19.35 | 19.30 | 19.14 | | |
| 5 | 12 | 0 | | 19.40 | 19.37 | 19.09 | | |
| 5 | 12 | 7 | | 19.17 | 19.26 | 18.97 | | |
| 5 | 12 | 13 | | 19.16 | 19.24 | 18.95 | | |
| 5 | 25 | 0 | | 19.40 | 19.27 | 19.10 | | |
| Limit | ERP < 3W | | | Result | | | Pass | |



| LTE Band 26(Part22H) Maximum Average Power [dBm] (GT - LC = -5.4 dB) | | | | | | | | |
|--|----------|-----------|---------|--------|--------|---------|-----------|---------|
| BW [MHz] | RB Size | RB Offset | Mod | Lowest | Middle | Highest | ERP (dBm) | ERP (W) |
| 15 | 1 | 0 | QPSK | 24.49 | 24.39 | 24.67 | 17.12 | 0.0515 |
| 15 | 1 | 37 | | 24.27 | 24.42 | 24.41 | | |
| 15 | 1 | 74 | | 24.32 | 24.22 | 24.35 | | |
| 15 | 36 | 0 | | 23.45 | 23.66 | 23.47 | | |
| 15 | 36 | 20 | | 23.43 | 23.53 | 23.46 | | |
| 15 | 36 | 39 | | 23.38 | 23.32 | 23.39 | | |
| 15 | 75 | 0 | | 23.40 | 23.51 | 23.44 | | |
| 15 | 1 | 0 | 16-QAM | 23.72 | 23.89 | 23.91 | 16.46 | 0.0443 |
| 15 | 1 | 37 | | 23.70 | 23.61 | 23.77 | | |
| 15 | 1 | 74 | | 23.78 | 24.01 | 23.53 | | |
| 15 | 36 | 0 | | 22.41 | 22.66 | 22.50 | | |
| 15 | 36 | 20 | | 22.41 | 22.37 | 22.45 | | |
| 15 | 36 | 39 | | 22.37 | 22.34 | 22.40 | | |
| 15 | 75 | 0 | | 22.43 | 22.30 | 22.48 | | |
| 15 | 1 | 0 | 64-QAM | 22.56 | 22.71 | 22.77 | 15.25 | 0.0335 |
| 15 | 1 | 37 | | 22.50 | 22.80 | 22.69 | | |
| 15 | 1 | 74 | | 22.50 | 22.59 | 22.45 | | |
| 15 | 36 | 0 | | 21.46 | 21.45 | 21.53 | | |
| 15 | 36 | 20 | | 21.44 | 21.43 | 21.46 | | |
| 15 | 36 | 39 | | 21.43 | 21.26 | 21.41 | | |
| 15 | 75 | 0 | | 21.41 | 21.39 | 21.47 | | |
| 15 | 1 | 0 | 256-QAM | 19.73 | 19.67 | 19.87 | 12.32 | 0.0171 |
| 15 | 1 | 37 | | 19.45 | 19.52 | 19.51 | | |
| 15 | 1 | 74 | | 19.41 | 19.48 | 19.51 | | |
| 15 | 36 | 0 | | 19.38 | 19.25 | 19.45 | | |
| 15 | 36 | 20 | | 19.39 | 19.35 | 19.46 | | |
| 15 | 36 | 39 | | 19.42 | 19.50 | 19.46 | | |
| 15 | 75 | 0 | | 19.35 | 19.43 | 19.39 | | |
| Limit | ERP < 7W | | | Result | | | Pass | |



| LTE Band 26(Part22H) Maximum Average Power [dBm] (GT - LC = -5.4 dB) | | | | | | | | |
|--|----------|-----------|---------|--------|--------|---------|-----------|---------|
| BW [MHz] | RB Size | RB Offset | Mod | Lowest | Middle | Highest | ERP (dBm) | ERP (W) |
| 10 | 1 | 0 | QPSK | 24.40 | 24.49 | 24.53 | 16.98 | 0.0499 |
| 10 | 1 | 25 | | 24.25 | 24.11 | 24.26 | | |
| 10 | 1 | 49 | | 24.37 | 24.30 | 24.21 | | |
| 10 | 25 | 0 | | 23.28 | 23.46 | 23.38 | | |
| 10 | 25 | 12 | | 23.36 | 23.25 | 23.40 | | |
| 10 | 25 | 25 | | 23.32 | 23.31 | 23.30 | | |
| 10 | 50 | 0 | | 23.21 | 23.21 | 23.37 | | |
| 10 | 1 | 0 | 16-QAM | 23.63 | 23.54 | 23.71 | 16.31 | 0.0428 |
| 10 | 1 | 25 | | 23.76 | 23.64 | 23.75 | | |
| 10 | 1 | 49 | | 23.86 | 23.67 | 23.33 | | |
| 10 | 25 | 0 | | 22.32 | 22.32 | 22.37 | | |
| 10 | 25 | 12 | | 22.28 | 22.38 | 22.27 | | |
| 10 | 25 | 25 | | 22.45 | 22.14 | 22.21 | | |
| 10 | 50 | 0 | | 22.45 | 22.36 | 22.33 | | |
| 10 | 1 | 0 | 64-QAM | 22.62 | 22.47 | 22.63 | 15.08 | 0.0322 |
| 10 | 1 | 25 | | 22.52 | 22.53 | 22.63 | | |
| 10 | 1 | 49 | | 22.42 | 22.34 | 22.34 | | |
| 10 | 25 | 0 | | 21.25 | 21.26 | 21.39 | | |
| 10 | 25 | 12 | | 21.25 | 21.33 | 21.46 | | |
| 10 | 25 | 25 | | 21.39 | 21.34 | 21.28 | | |
| 10 | 50 | 0 | | 21.38 | 21.36 | 21.46 | | |
| 10 | 1 | 0 | 256-QAM | 19.54 | 19.62 | 19.82 | 12.27 | 0.0169 |
| 10 | 1 | 25 | | 19.28 | 19.28 | 19.42 | | |
| 10 | 1 | 49 | | 19.41 | 19.35 | 19.40 | | |
| 10 | 25 | 0 | | 19.17 | 19.24 | 19.33 | | |
| 10 | 25 | 12 | | 19.27 | 19.23 | 19.30 | | |
| 10 | 25 | 25 | | 19.38 | 19.29 | 19.45 | | |
| 10 | 50 | 0 | | 19.26 | 19.41 | 19.39 | | |
| Limit | ERP < 7W | | | Result | | | Pass | |



| LTE Band 26(Part22H) Maximum Average Power [dBm] (GT - LC = -5.4 dB) | | | | | | | | |
|--|----------|-----------|---------|--------|--------|---------|-----------|---------|
| BW [MHz] | RB Size | RB Offset | Mod | Lowest | Middle | Highest | ERP (dBm) | ERP (W) |
| 5 | 1 | 0 | QPSK | 24.46 | 24.44 | 24.64 | 17.09 | 0.0512 |
| 5 | 1 | 12 | | 24.32 | 24.18 | 24.30 | | |
| 5 | 1 | 24 | | 24.13 | 24.30 | 24.29 | | |
| 5 | 12 | 0 | | 23.34 | 23.27 | 23.43 | | |
| 5 | 12 | 7 | | 23.44 | 23.29 | 23.31 | | |
| 5 | 12 | 13 | | 23.29 | 23.25 | 23.27 | | |
| 5 | 25 | 0 | | 23.22 | 23.40 | 23.29 | | |
| 5 | 1 | 0 | 16-QAM | 23.61 | 23.53 | 23.90 | 16.35 | 0.0432 |
| 5 | 1 | 12 | | 23.80 | 23.55 | 23.74 | | |
| 5 | 1 | 24 | | 23.68 | 23.69 | 23.34 | | |
| 5 | 12 | 0 | | 22.42 | 22.33 | 22.38 | | |
| 5 | 12 | 7 | | 22.20 | 22.24 | 22.38 | | |
| 5 | 12 | 13 | | 22.30 | 22.20 | 22.31 | | |
| 5 | 25 | 0 | | 22.30 | 22.38 | 22.45 | | |
| 5 | 1 | 0 | 64-QAM | 22.56 | 22.49 | 22.59 | 15.07 | 0.0321 |
| 5 | 1 | 12 | | 22.62 | 22.46 | 22.49 | | |
| 5 | 1 | 24 | | 22.52 | 22.32 | 22.43 | | |
| 5 | 12 | 0 | | 21.52 | 21.51 | 21.47 | | |
| 5 | 12 | 7 | | 21.51 | 21.23 | 21.38 | | |
| 5 | 12 | 13 | | 21.44 | 21.31 | 21.37 | | |
| 5 | 25 | 0 | | 21.32 | 21.32 | 21.40 | | |
| 5 | 1 | 0 | 256-QAM | 19.66 | 19.70 | 19.75 | 12.20 | 0.0166 |
| 5 | 1 | 12 | | 19.19 | 19.27 | 19.31 | | |
| 5 | 1 | 24 | | 19.40 | 19.27 | 19.33 | | |
| 5 | 12 | 0 | | 19.37 | 19.24 | 19.38 | | |
| 5 | 12 | 7 | | 19.16 | 19.13 | 19.32 | | |
| 5 | 12 | 13 | | 19.40 | 19.42 | 19.28 | | |
| 5 | 25 | 0 | | 19.22 | 19.12 | 19.27 | | |
| Limit | ERP < 7W | | | Result | | | Pass | |



| LTE Band 26(Part22H) Maximum Average Power [dBm] (GT - LC = -5.4 dB) | | | | | | | | |
|--|----------|-----------|---------|--------|--------|---------|-----------|---------|
| BW [MHz] | RB Size | RB Offset | Mod | Lowest | Middle | Highest | ERP (dBm) | ERP (W) |
| 3 | 1 | 0 | QPSK | 24.56 | 24.44 | 24.57 | 17.02 | 0.0504 |
| 3 | 1 | 8 | | 24.22 | 24.17 | 24.32 | | |
| 3 | 1 | 14 | | 24.35 | 24.12 | 24.19 | | |
| 3 | 8 | 0 | | 23.23 | 23.32 | 23.41 | | |
| 3 | 8 | 4 | | 23.34 | 23.19 | 23.45 | | |
| 3 | 8 | 7 | | 23.23 | 23.37 | 23.23 | | |
| 3 | 15 | 0 | | 23.29 | 23.42 | 23.25 | | |
| 3 | 1 | 0 | 16-QAM | 23.59 | 23.58 | 23.80 | 16.25 | 0.0422 |
| 3 | 1 | 8 | | 23.63 | 23.62 | 23.76 | | |
| 3 | 1 | 14 | | 23.60 | 23.63 | 23.47 | | |
| 3 | 8 | 0 | | 22.35 | 22.25 | 22.31 | | |
| 3 | 8 | 4 | | 22.37 | 22.47 | 22.31 | | |
| 3 | 8 | 7 | | 22.29 | 22.30 | 22.34 | | |
| 3 | 15 | 0 | | 22.28 | 22.30 | 22.35 | | |
| 3 | 1 | 0 | 64-QAM | 22.71 | 22.37 | 22.72 | 15.17 | 0.0329 |
| 3 | 1 | 8 | | 22.46 | 22.42 | 22.55 | | |
| 3 | 1 | 14 | | 22.50 | 22.38 | 22.45 | | |
| 3 | 8 | 0 | | 21.49 | 21.42 | 21.51 | | |
| 3 | 8 | 4 | | 21.32 | 21.47 | 21.33 | | |
| 3 | 8 | 7 | | 21.32 | 21.33 | 21.29 | | |
| 3 | 15 | 0 | | 21.19 | 21.31 | 21.37 | | |
| 3 | 1 | 0 | 256-QAM | 19.71 | 19.80 | 19.84 | 12.29 | 0.0169 |
| 3 | 1 | 8 | | 19.32 | 19.18 | 19.44 | | |
| 3 | 1 | 14 | | 19.33 | 19.25 | 19.32 | | |
| 3 | 8 | 0 | | 19.27 | 19.38 | 19.45 | | |
| 3 | 8 | 4 | | 19.36 | 19.38 | 19.41 | | |
| 3 | 8 | 7 | | 19.06 | 19.40 | 19.44 | | |
| 3 | 15 | 0 | | 19.14 | 19.32 | 19.28 | | |
| Limit | ERP < 7W | | | Result | | | Pass | |



| LTE Band 26(Part22H) Maximum Average Power [dBm] (GT - LC = -5.4 dB) | | | | | | | | |
|--|----------|-----------|---------|--------|--------|---------|-----------|---------|
| BW [MHz] | RB Size | RB Offset | Mod | Lowest | Middle | Highest | ERP (dBm) | ERP (W) |
| 1.4 | 1 | 0 | QPSK | 24.29 | 24.49 | 24.52 | 16.97 | 0.0498 |
| 1.4 | 1 | 3 | | 24.23 | 24.35 | 24.41 | | |
| 1.4 | 1 | 5 | | 24.25 | 24.23 | 24.35 | | |
| 1.4 | 3 | 0 | | 24.44 | 24.47 | 24.51 | | |
| 1.4 | 3 | 1 | | 24.40 | 24.25 | 24.25 | | |
| 1.4 | 3 | 3 | | 24.19 | 24.15 | 24.22 | | |
| 1.4 | 6 | 0 | | 23.39 | 23.41 | 23.31 | | |
| 1.4 | 1 | 0 | 16-QAM | 23.15 | 23.37 | 23.33 | 16.21 | 0.0418 |
| 1.4 | 1 | 3 | | 23.41 | 23.42 | 23.36 | | |
| 1.4 | 1 | 5 | | 23.34 | 23.22 | 23.28 | | |
| 1.4 | 3 | 0 | | 23.73 | 23.61 | 23.71 | | |
| 1.4 | 3 | 1 | | 23.57 | 23.66 | 23.72 | | |
| 1.4 | 3 | 3 | | 23.76 | 23.64 | 23.35 | | |
| 1.4 | 6 | 0 | | 22.32 | 22.24 | 22.46 | | |
| 1.4 | 1 | 0 | 64-QAM | 22.46 | 22.30 | 22.41 | 15.15 | 0.0327 |
| 1.4 | 1 | 3 | | 22.33 | 22.12 | 22.23 | | |
| 1.4 | 1 | 5 | | 22.25 | 22.32 | 22.28 | | |
| 1.4 | 3 | 0 | | 22.59 | 22.45 | 22.70 | | |
| 1.4 | 3 | 1 | | 22.54 | 22.52 | 22.69 | | |
| 1.4 | 3 | 3 | | 22.52 | 22.45 | 22.39 | | |
| 1.4 | 6 | 0 | | 21.32 | 21.32 | 21.38 | | |
| 1.4 | 1 | 0 | 256-QAM | 19.55 | 19.72 | 19.72 | 12.17 | 0.0165 |
| 1.4 | 1 | 3 | | 19.19 | 19.50 | 19.48 | | |
| 1.4 | 1 | 5 | | 19.19 | 19.37 | 19.37 | | |
| 1.4 | 3 | 0 | | 19.32 | 19.29 | 19.45 | | |
| 1.4 | 3 | 1 | | 19.17 | 19.25 | 19.40 | | |
| 1.4 | 3 | 3 | | 19.05 | 19.31 | 19.28 | | |
| 1.4 | 6 | 0 | | 19.19 | 19.11 | 19.24 | | |
| Limit | ERP < 7W | | | Result | | | Pass | |



| LTE Band 38 Maximum Average Power [dBm] (GT - LC = -1.49 dB) | | | | | | | | |
|--|-----------|-----------|---------|--------|--------|---------|------------|----------|
| BW [MHz] | RB Size | RB Offset | Mod | Lowest | Middle | Highest | EIRP (dBm) | EIRP (W) |
| 20 | 1 | 0 | QPSK | 24.31 | 24.33 | 24.34 | 22.85 | 0.1928 |
| 20 | 1 | 49 | | 24.25 | 24.29 | 24.31 | | |
| 20 | 1 | 99 | | 24.25 | 24.24 | 24.29 | | |
| 20 | 50 | 0 | | 23.30 | 23.29 | 23.34 | | |
| 20 | 50 | 24 | | 23.27 | 23.24 | 23.33 | | |
| 20 | 50 | 50 | | 23.28 | 23.28 | 23.31 | | |
| 20 | 100 | 0 | | 23.28 | 23.28 | 23.29 | | |
| 20 | 1 | 0 | 16-QAM | 23.36 | 23.43 | 23.33 | 21.94 | 0.1563 |
| 20 | 1 | 49 | | 23.30 | 23.34 | 23.27 | | |
| 20 | 1 | 99 | | 23.30 | 23.34 | 23.36 | | |
| 20 | 50 | 0 | | 22.30 | 22.28 | 22.32 | | |
| 20 | 50 | 24 | | 22.30 | 22.35 | 22.37 | | |
| 20 | 50 | 50 | | 22.33 | 22.34 | 22.33 | | |
| 20 | 100 | 0 | | 22.35 | 22.36 | 22.36 | | |
| 20 | 1 | 0 | 64-QAM | 22.08 | 22.00 | 22.05 | 20.60 | 0.1148 |
| 20 | 1 | 49 | | 22.03 | 21.96 | 21.91 | | |
| 20 | 1 | 99 | | 22.09 | 22.04 | 21.95 | | |
| 20 | 50 | 0 | | 21.35 | 21.35 | 21.35 | | |
| 20 | 50 | 24 | | 21.33 | 21.33 | 21.36 | | |
| 20 | 50 | 50 | | 21.32 | 21.29 | 21.36 | | |
| 20 | 100 | 0 | | 21.32 | 21.31 | 21.36 | | |
| 20 | 1 | 0 | 256-QAM | 19.48 | 19.39 | 19.44 | 17.99 | 0.0630 |
| 20 | 1 | 49 | | 19.17 | 19.12 | 19.08 | | |
| 20 | 1 | 99 | | 19.17 | 19.09 | 19.13 | | |
| 20 | 50 | 0 | | 17.51 | 17.46 | 17.45 | | |
| 20 | 50 | 24 | | 17.41 | 17.38 | 17.39 | | |
| 20 | 50 | 50 | | 17.40 | 17.35 | 17.37 | | |
| 20 | 100 | 0 | | 17.39 | 17.34 | 17.32 | | |
| Limit | EIRP < 2W | | | Result | | | Pass | |



| LTE Band 38 Maximum Average Power [dBm] (GT - LC = -1.49 dB) | | | | | | | | |
|--|-----------|-----------|---------|--------|--------|---------|------------|----------|
| BW [MHz] | RB Size | RB Offset | Mod | Lowest | Middle | Highest | EIRP (dBm) | EIRP (W) |
| 15 | 1 | 0 | QPSK | 24.16 | 24.30 | 24.16 | 22.81 | 0.1910 |
| 15 | 1 | 37 | | 24.17 | 24.27 | 24.18 | | |
| 15 | 1 | 74 | | 24.18 | 24.21 | 24.23 | | |
| 15 | 36 | 0 | | 23.16 | 23.28 | 23.33 | | |
| 15 | 36 | 20 | | 23.13 | 23.05 | 23.25 | | |
| 15 | 36 | 39 | | 23.08 | 23.09 | 23.14 | | |
| 15 | 75 | 0 | | 23.09 | 23.14 | 23.21 | | |
| 15 | 1 | 0 | 16-QAM | 23.34 | 23.33 | 23.15 | 21.85 | 0.1531 |
| 15 | 1 | 37 | | 23.15 | 23.33 | 23.26 | | |
| 15 | 1 | 74 | | 23.28 | 23.28 | 23.19 | | |
| 15 | 36 | 0 | | 22.23 | 22.09 | 22.26 | | |
| 15 | 36 | 20 | | 22.21 | 22.22 | 22.32 | | |
| 15 | 36 | 39 | | 22.23 | 22.27 | 22.28 | | |
| 15 | 75 | 0 | | 22.33 | 22.30 | 22.29 | | |
| 15 | 1 | 0 | 64-QAM | 22.04 | 21.94 | 21.95 | 20.56 | 0.1138 |
| 15 | 1 | 37 | | 21.98 | 21.79 | 21.91 | | |
| 15 | 1 | 74 | | 22.05 | 21.88 | 21.81 | | |
| 15 | 36 | 0 | | 21.16 | 21.31 | 21.26 | | |
| 15 | 36 | 20 | | 21.23 | 21.17 | 21.32 | | |
| 15 | 36 | 39 | | 21.28 | 21.11 | 21.17 | | |
| 15 | 75 | 0 | | 21.31 | 21.15 | 21.33 | | |
| 15 | 1 | 0 | 256-QAM | 19.28 | 19.36 | 19.32 | 17.87 | 0.0612 |
| 15 | 1 | 37 | | 19.11 | 18.96 | 18.90 | | |
| 15 | 1 | 74 | | 19.12 | 18.99 | 19.00 | | |
| 15 | 36 | 0 | | 17.46 | 17.33 | 17.35 | | |
| 15 | 36 | 20 | | 17.27 | 17.18 | 17.37 | | |
| 15 | 36 | 39 | | 17.20 | 17.32 | 17.33 | | |
| 15 | 75 | 0 | | 17.21 | 17.28 | 17.14 | | |
| Limit | EIRP < 2W | | | Result | | | Pass | |



| LTE Band 38 Maximum Average Power [dBm] (GT - LC = -1.49 dB) | | | | | | | | |
|--|-----------|-----------|---------|--------|--------|---------|------------|----------|
| BW [MHz] | RB Size | RB Offset | Mod | Lowest | Middle | Highest | EIRP (dBm) | EIRP (W) |
| 10 | 1 | 0 | QPSK | 24.31 | 24.20 | 24.26 | 22.82 | 0.1914 |
| 10 | 1 | 25 | | 24.10 | 24.25 | 24.12 | | |
| 10 | 1 | 49 | | 24.06 | 24.17 | 24.23 | | |
| 10 | 25 | 0 | | 23.23 | 23.25 | 23.31 | | |
| 10 | 25 | 12 | | 23.11 | 23.23 | 23.20 | | |
| 10 | 25 | 25 | | 23.25 | 23.14 | 23.30 | | |
| 10 | 50 | 0 | | 23.27 | 23.21 | 23.17 | | |
| 10 | 1 | 0 | 16-QAM | 23.32 | 23.36 | 23.17 | 21.87 | 0.1538 |
| 10 | 1 | 25 | | 23.28 | 23.25 | 23.22 | | |
| 10 | 1 | 49 | | 23.18 | 23.17 | 23.21 | | |
| 10 | 25 | 0 | | 22.16 | 22.21 | 22.21 | | |
| 10 | 25 | 12 | | 22.14 | 22.30 | 22.21 | | |
| 10 | 25 | 25 | | 22.15 | 22.18 | 22.31 | | |
| 10 | 50 | 0 | | 22.26 | 22.16 | 22.17 | | |
| 10 | 1 | 0 | 64-QAM | 21.96 | 21.93 | 21.85 | 20.48 | 0.1117 |
| 10 | 1 | 25 | | 21.83 | 21.82 | 21.88 | | |
| 10 | 1 | 49 | | 21.97 | 21.95 | 21.82 | | |
| 10 | 25 | 0 | | 21.24 | 21.33 | 21.30 | | |
| 10 | 25 | 12 | | 21.13 | 21.32 | 21.33 | | |
| 10 | 25 | 25 | | 21.31 | 21.25 | 21.36 | | |
| 10 | 50 | 0 | | 21.29 | 21.20 | 21.16 | | |
| 10 | 1 | 0 | 256-QAM | 19.34 | 19.30 | 19.33 | 17.85 | 0.0610 |
| 10 | 1 | 25 | | 19.15 | 18.98 | 18.98 | | |
| 10 | 1 | 49 | | 19.06 | 19.02 | 19.13 | | |
| 10 | 25 | 0 | | 17.47 | 17.30 | 17.25 | | |
| 10 | 25 | 12 | | 17.22 | 17.22 | 17.25 | | |
| 10 | 25 | 25 | | 17.24 | 17.18 | 17.31 | | |
| 10 | 50 | 0 | | 17.27 | 17.29 | 17.27 | | |
| Limit | EIRP < 2W | | | Result | | | Pass | |



| LTE Band 38 Maximum Average Power [dBm] (GT - LC = -1.49 dB) | | | | | | | | |
|--|-----------|-----------|---------|--------|--------|---------|------------|----------|
| BW [MHz] | RB Size | RB Offset | Mod | Lowest | Middle | Highest | EIRP (dBm) | EIRP (W) |
| 5 | 1 | 0 | QPSK | 24.21 | 24.22 | 24.25 | 22.78 | 0.1897 |
| 5 | 1 | 12 | | 24.23 | 24.27 | 24.15 | | |
| 5 | 1 | 24 | | 24.22 | 24.10 | 24.20 | | |
| 5 | 12 | 0 | | 23.29 | 23.27 | 23.14 | | |
| 5 | 12 | 7 | | 23.07 | 23.08 | 23.25 | | |
| 5 | 12 | 13 | | 23.13 | 23.15 | 23.19 | | |
| 5 | 25 | 0 | | 23.18 | 23.16 | 23.15 | | |
| 5 | 1 | 0 | 16-QAM | 23.31 | 23.43 | 23.22 | 21.94 | 0.1563 |
| 5 | 1 | 12 | | 23.20 | 23.30 | 23.16 | | |
| 5 | 1 | 24 | | 23.16 | 23.26 | 23.36 | | |
| 5 | 12 | 0 | | 22.20 | 22.25 | 22.31 | | |
| 5 | 12 | 7 | | 22.13 | 22.27 | 22.22 | | |
| 5 | 12 | 13 | | 22.20 | 22.22 | 22.32 | | |
| 5 | 25 | 0 | | 22.16 | 22.17 | 22.30 | | |
| 5 | 1 | 0 | 64-QAM | 22.04 | 21.80 | 22.05 | 20.56 | 0.1138 |
| 5 | 1 | 12 | | 21.92 | 21.86 | 21.79 | | |
| 5 | 1 | 24 | | 21.95 | 21.86 | 21.78 | | |
| 5 | 12 | 0 | | 21.34 | 21.23 | 21.23 | | |
| 5 | 12 | 7 | | 21.24 | 21.31 | 21.28 | | |
| 5 | 12 | 13 | | 21.15 | 21.15 | 21.34 | | |
| 5 | 25 | 0 | | 21.23 | 21.22 | 21.30 | | |
| 5 | 1 | 0 | 256-QAM | 19.48 | 19.36 | 19.29 | 17.99 | 0.0630 |
| 5 | 1 | 12 | | 18.97 | 19.02 | 18.92 | | |
| 5 | 1 | 24 | | 19.08 | 19.04 | 19.00 | | |
| 5 | 12 | 0 | | 17.43 | 17.41 | 17.37 | | |
| 5 | 12 | 7 | | 17.37 | 17.31 | 17.29 | | |
| 5 | 12 | 13 | | 17.21 | 17.24 | 17.32 | | |
| 5 | 25 | 0 | | 17.38 | 17.20 | 17.32 | | |
| Limit | EIRP < 2W | | | Result | | | Pass | |



| LTE Band 38(HPUE) Maximum Average Power [dBm] (GT - LC = -1.49 dB) | | | | | | | | |
|--|-----------|-----------|---------|--------|--------|---------|------------|----------|
| BW [MHz] | RB Size | RB Offset | Mod | Lowest | Middle | Highest | EIRP (dBm) | EIRP (W) |
| 20 | 1 | 0 | QPSK | 25.98 | 25.94 | 25.95 | 24.49 | 0.2812 |
| 20 | 1 | 49 | | 25.96 | 25.91 | 25.92 | | |
| 20 | 1 | 99 | | 25.91 | 25.92 | 25.93 | | |
| 20 | 50 | 0 | | 24.98 | 24.97 | 24.97 | | |
| 20 | 50 | 24 | | 24.96 | 24.95 | 24.96 | | |
| 20 | 50 | 50 | | 24.94 | 24.95 | 24.95 | | |
| 20 | 100 | 0 | | 24.98 | 24.93 | 24.95 | | |
| 20 | 1 | 0 | 16-QAM | 25.46 | 25.59 | 25.35 | 24.10 | 0.2570 |
| 20 | 1 | 49 | | 25.46 | 25.45 | 25.43 | | |
| 20 | 1 | 99 | | 25.49 | 25.50 | 25.49 | | |
| 20 | 50 | 0 | | 23.98 | 23.97 | 23.99 | | |
| 20 | 50 | 24 | | 23.94 | 23.93 | 23.95 | | |
| 20 | 50 | 50 | | 23.93 | 23.93 | 23.97 | | |
| 20 | 100 | 0 | | 23.96 | 23.95 | 24.04 | | |
| 20 | 1 | 0 | 64-QAM | 23.90 | 24.14 | 24.15 | 22.66 | 0.1845 |
| 20 | 1 | 49 | | 23.81 | 23.83 | 23.86 | | |
| 20 | 1 | 99 | | 23.80 | 23.80 | 23.86 | | |
| 20 | 50 | 0 | | 22.97 | 22.96 | 22.99 | | |
| 20 | 50 | 24 | | 22.97 | 23.00 | 22.99 | | |
| 20 | 50 | 50 | | 22.99 | 22.98 | 23.00 | | |
| 20 | 100 | 0 | | 22.97 | 22.97 | 23.01 | | |
| 20 | 1 | 0 | 256-QAM | 21.49 | 21.63 | 21.63 | 20.14 | 0.1033 |
| 20 | 1 | 49 | | 21.15 | 21.33 | 21.25 | | |
| 20 | 1 | 99 | | 21.12 | 21.31 | 21.23 | | |
| 20 | 50 | 0 | | 18.90 | 19.14 | 19.12 | | |
| 20 | 50 | 24 | | 18.93 | 19.08 | 19.08 | | |
| 20 | 50 | 50 | | 18.86 | 19.01 | 18.93 | | |
| 20 | 100 | 0 | | 18.80 | 19.01 | 18.99 | | |
| Limit | EIRP < 2W | | | Result | | | Pass | |



| LTE Band 38(HPUE) Maximum Average Power [dBm] (GT - LC = -1.49 dB) | | | | | | | | |
|--|-----------|-----------|---------|--------|--------|---------|------------|----------|
| BW [MHz] | RB Size | RB Offset | Mod | Lowest | Middle | Highest | EIRP (dBm) | EIRP (W) |
| 15 | 1 | 0 | QPSK | 25.83 | 25.92 | 25.86 | 24.44 | 0.2780 |
| 15 | 1 | 37 | | 25.82 | 25.73 | 25.75 | | |
| 15 | 1 | 74 | | 25.88 | 25.91 | 25.93 | | |
| 15 | 36 | 0 | | 24.94 | 24.83 | 24.77 | | |
| 15 | 36 | 20 | | 24.79 | 24.86 | 24.76 | | |
| 15 | 36 | 39 | | 24.76 | 24.90 | 24.81 | | |
| 15 | 75 | 0 | | 24.95 | 24.93 | 24.80 | | |
| 15 | 1 | 0 | 16-QAM | 25.42 | 25.47 | 25.31 | 23.98 | 0.2500 |
| 15 | 1 | 37 | | 25.40 | 25.28 | 25.23 | | |
| 15 | 1 | 74 | | 25.45 | 25.42 | 25.45 | | |
| 15 | 36 | 0 | | 23.86 | 23.86 | 23.80 | | |
| 15 | 36 | 20 | | 23.77 | 23.80 | 23.84 | | |
| 15 | 36 | 39 | | 23.81 | 23.78 | 23.84 | | |
| 15 | 75 | 0 | | 23.76 | 23.83 | 24.04 | | |
| 15 | 1 | 0 | 64-QAM | 23.88 | 23.97 | 24.11 | 22.62 | 0.1828 |
| 15 | 1 | 37 | | 23.74 | 23.83 | 23.79 | | |
| 15 | 1 | 74 | | 23.65 | 23.61 | 23.80 | | |
| 15 | 36 | 0 | | 22.79 | 22.83 | 22.79 | | |
| 15 | 36 | 20 | | 22.83 | 22.91 | 22.94 | | |
| 15 | 36 | 39 | | 22.92 | 22.95 | 22.93 | | |
| 15 | 75 | 0 | | 22.97 | 22.93 | 22.92 | | |
| 15 | 1 | 0 | 256-QAM | 21.43 | 21.51 | 21.55 | 20.06 | 0.1014 |
| 15 | 1 | 37 | | 21.07 | 21.14 | 21.21 | | |
| 15 | 1 | 74 | | 21.10 | 21.25 | 21.15 | | |
| 15 | 36 | 0 | | 18.81 | 18.98 | 19.02 | | |
| 15 | 36 | 20 | | 18.78 | 18.90 | 18.98 | | |
| 15 | 36 | 39 | | 18.68 | 18.87 | 18.93 | | |
| 15 | 75 | 0 | | 18.71 | 18.99 | 18.94 | | |
| Limit | EIRP < 2W | | | Result | | | Pass | |



| LTE Band 38(HPUE) Maximum Average Power [dBm] (GT - LC = -1.49 dB) | | | | | | | | |
|--|-----------|-----------|---------|--------|--------|---------|------------|----------|
| BW [MHz] | RB Size | RB Offset | Mod | Lowest | Middle | Highest | EIRP (dBm) | EIRP (W) |
| 10 | 1 | 0 | QPSK | 25.85 | 25.88 | 25.95 | 24.46 | 0.2793 |
| 10 | 1 | 25 | | 25.84 | 25.82 | 25.80 | | |
| 10 | 1 | 49 | | 25.91 | 25.89 | 25.77 | | |
| 10 | 25 | 0 | | 24.83 | 24.90 | 24.97 | | |
| 10 | 25 | 12 | | 24.76 | 24.82 | 24.81 | | |
| 10 | 25 | 25 | | 24.84 | 24.95 | 24.88 | | |
| 10 | 50 | 0 | | 24.90 | 24.74 | 24.84 | | |
| 10 | 1 | 0 | 16-QAM | 25.46 | 25.58 | 25.35 | 24.09 | 0.2564 |
| 10 | 1 | 25 | | 25.27 | 25.39 | 25.36 | | |
| 10 | 1 | 49 | | 25.30 | 25.37 | 25.37 | | |
| 10 | 25 | 0 | | 23.90 | 23.95 | 23.98 | | |
| 10 | 25 | 12 | | 23.91 | 23.82 | 23.80 | | |
| 10 | 25 | 25 | | 23.77 | 23.87 | 23.85 | | |
| 10 | 50 | 0 | | 23.82 | 23.88 | 23.84 | | |
| 10 | 1 | 0 | 64-QAM | 23.75 | 24.10 | 24.08 | 22.61 | 0.1824 |
| 10 | 1 | 25 | | 23.78 | 23.70 | 23.66 | | |
| 10 | 1 | 49 | | 23.63 | 23.67 | 23.82 | | |
| 10 | 25 | 0 | | 22.89 | 22.82 | 22.79 | | |
| 10 | 25 | 12 | | 22.90 | 22.94 | 22.91 | | |
| 10 | 25 | 25 | | 22.98 | 22.82 | 22.82 | | |
| 10 | 50 | 0 | | 22.83 | 22.80 | 22.99 | | |
| 10 | 1 | 0 | 256-QAM | 21.45 | 21.55 | 21.51 | 20.06 | 0.1014 |
| 10 | 1 | 25 | | 21.15 | 21.15 | 21.20 | | |
| 10 | 1 | 49 | | 21.06 | 21.23 | 21.19 | | |
| 10 | 25 | 0 | | 18.76 | 19.01 | 18.93 | | |
| 10 | 25 | 12 | | 18.79 | 18.96 | 19.04 | | |
| 10 | 25 | 25 | | 18.68 | 18.81 | 18.83 | | |
| 10 | 50 | 0 | | 18.61 | 18.85 | 18.97 | | |
| Limit | EIRP < 2W | | | Result | | | Pass | |



| LTE Band 38(HPUE) Maximum Average Power [dBm] (GT - LC = -1.49 dB) | | | | | | | | |
|--|-----------|-----------|---------|--------|--------|---------|------------|----------|
| BW [MHz] | RB Size | RB Offset | Mod | Lowest | Middle | Highest | EIRP (dBm) | EIRP (W) |
| 5 | 1 | 0 | QPSK | 25.81 | 25.91 | 25.87 | 24.43 | 0.2773 |
| 5 | 1 | 12 | | 25.92 | 25.90 | 25.88 | | |
| 5 | 1 | 24 | | 25.76 | 25.83 | 25.86 | | |
| 5 | 12 | 0 | | 24.85 | 24.90 | 24.77 | | |
| 5 | 12 | 7 | | 24.90 | 24.78 | 24.95 | | |
| 5 | 12 | 13 | | 24.93 | 24.86 | 24.95 | | |
| 5 | 25 | 0 | | 24.93 | 24.78 | 24.94 | | |
| 5 | 1 | 0 | 16-QAM | 25.29 | 25.46 | 25.33 | 23.97 | 0.2495 |
| 5 | 1 | 12 | | 25.36 | 25.37 | 25.35 | | |
| 5 | 1 | 24 | | 25.42 | 25.38 | 25.34 | | |
| 5 | 12 | 0 | | 23.98 | 23.81 | 23.79 | | |
| 5 | 12 | 7 | | 23.92 | 23.79 | 23.87 | | |
| 5 | 12 | 13 | | 23.83 | 23.75 | 23.84 | | |
| 5 | 25 | 0 | | 23.96 | 23.81 | 23.91 | | |
| 5 | 1 | 0 | 64-QAM | 23.77 | 23.95 | 24.05 | 22.56 | 0.1803 |
| 5 | 1 | 12 | | 23.73 | 23.69 | 23.71 | | |
| 5 | 1 | 24 | | 23.72 | 23.68 | 23.85 | | |
| 5 | 12 | 0 | | 22.81 | 22.83 | 22.98 | | |
| 5 | 12 | 7 | | 22.82 | 22.82 | 22.87 | | |
| 5 | 12 | 13 | | 22.99 | 22.98 | 22.95 | | |
| 5 | 25 | 0 | | 22.82 | 22.94 | 22.86 | | |
| 5 | 1 | 0 | 256-QAM | 21.34 | 21.63 | 21.44 | 20.14 | 0.1033 |
| 5 | 1 | 12 | | 21.01 | 21.18 | 21.16 | | |
| 5 | 1 | 24 | | 21.01 | 21.28 | 21.04 | | |
| 5 | 12 | 0 | | 18.82 | 19.06 | 19.05 | | |
| 5 | 12 | 7 | | 18.90 | 19.08 | 18.90 | | |
| 5 | 12 | 13 | | 18.85 | 18.99 | 18.78 | | |
| 5 | 25 | 0 | | 18.63 | 18.83 | 18.84 | | |
| Limit | EIRP < 2W | | | Result | | | Pass | |



| LTE Band 41 Maximum Average Power [dBm] (GT - LC = -0.44 dB) | | | | | | | | |
|--|-----------|-----------|---------|--------|--------|---------|------------|----------|
| BW [MHz] | RB Size | RB Offset | Mod | Lowest | Middle | Highest | EIRP (dBm) | EIRP (W) |
| 20 | 1 | 0 | QPSK | 24.09 | 24.05 | 24.06 | 23.65 | 0.2317 |
| 20 | 1 | 49 | | 24.04 | 24.02 | 24.00 | | |
| 20 | 1 | 99 | | 24.05 | 24.03 | 24.03 | | |
| 20 | 50 | 0 | | 23.10 | 23.07 | 23.05 | | |
| 20 | 50 | 24 | | 23.09 | 23.05 | 23.03 | | |
| 20 | 50 | 50 | | 23.09 | 23.01 | 23.01 | | |
| 20 | 100 | 0 | | 23.10 | 23.01 | 23.06 | | |
| 20 | 1 | 0 | 16-QAM | 23.14 | 23.12 | 23.11 | 22.70 | 0.1862 |
| 20 | 1 | 49 | | 23.06 | 23.02 | 23.11 | | |
| 20 | 1 | 99 | | 23.07 | 23.05 | 23.14 | | |
| 20 | 50 | 0 | | 22.08 | 22.05 | 22.03 | | |
| 20 | 50 | 24 | | 22.05 | 22.06 | 22.05 | | |
| 20 | 50 | 50 | | 22.05 | 22.04 | 22.04 | | |
| 20 | 100 | 0 | | 22.08 | 22.07 | 22.06 | | |
| 20 | 1 | 0 | 64-QAM | 21.71 | 21.70 | 21.61 | 21.27 | 0.1340 |
| 20 | 1 | 49 | | 21.70 | 21.53 | 21.48 | | |
| 20 | 1 | 99 | | 21.68 | 21.58 | 21.57 | | |
| 20 | 50 | 0 | | 21.08 | 21.07 | 21.09 | | |
| 20 | 50 | 24 | | 21.09 | 21.08 | 21.10 | | |
| 20 | 50 | 50 | | 21.09 | 21.04 | 21.10 | | |
| 20 | 100 | 0 | | 21.10 | 21.07 | 21.06 | | |
| 20 | 1 | 0 | 256-QAM | 19.09 | 19.14 | 19.04 | 18.70 | 0.0741 |
| 20 | 1 | 49 | | 18.87 | 18.95 | 18.75 | | |
| 20 | 1 | 99 | | 18.81 | 18.92 | 18.82 | | |
| 20 | 50 | 0 | | 17.11 | 17.18 | 17.05 | | |
| 20 | 50 | 24 | | 16.99 | 17.13 | 16.98 | | |
| 20 | 50 | 50 | | 16.94 | 17.06 | 16.91 | | |
| 20 | 100 | 0 | | 16.98 | 17.05 | 16.93 | | |
| Limit | EIRP < 2W | | | Result | | | Pass | |



| LTE Band 41 Maximum Average Power [dBm] (GT - LC = -0.44 dB) | | | | | | | | |
|--|-----------|-----------|---------|--------|--------|---------|------------|----------|
| BW [MHz] | RB Size | RB Offset | Mod | Lowest | Middle | Highest | EIRP (dBm) | EIRP (W) |
| 15 | 1 | 0 | QPSK | 24.05 | 24.02 | 24.01 | 23.61 | 0.2296 |
| 15 | 1 | 37 | | 23.93 | 23.98 | 23.85 | | |
| 15 | 1 | 74 | | 23.98 | 23.93 | 23.86 | | |
| 15 | 36 | 0 | | 22.94 | 22.95 | 22.85 | | |
| 15 | 36 | 20 | | 22.91 | 22.97 | 22.97 | | |
| 15 | 36 | 39 | | 22.98 | 22.85 | 22.83 | | |
| 15 | 75 | 0 | | 23.07 | 22.95 | 22.96 | | |
| 15 | 1 | 0 | 16-QAM | 22.97 | 23.03 | 22.91 | 22.61 | 0.1824 |
| 15 | 1 | 37 | | 22.94 | 22.88 | 22.96 | | |
| 15 | 1 | 74 | | 22.96 | 23.05 | 22.98 | | |
| 15 | 36 | 0 | | 21.93 | 21.87 | 21.98 | | |
| 15 | 36 | 20 | | 21.96 | 21.91 | 21.93 | | |
| 15 | 36 | 39 | | 21.99 | 21.95 | 22.02 | | |
| 15 | 75 | 0 | | 22.05 | 21.97 | 21.96 | | |
| 15 | 1 | 0 | 64-QAM | 21.60 | 21.61 | 21.58 | 21.17 | 0.1309 |
| 15 | 1 | 37 | | 21.53 | 21.49 | 21.42 | | |
| 15 | 1 | 74 | | 21.53 | 21.47 | 21.52 | | |
| 15 | 36 | 0 | | 20.89 | 21.06 | 21.00 | | |
| 15 | 36 | 20 | | 20.91 | 20.91 | 21.02 | | |
| 15 | 36 | 39 | | 21.05 | 21.04 | 20.97 | | |
| 15 | 75 | 0 | | 21.01 | 20.92 | 20.94 | | |
| 15 | 1 | 0 | 256-QAM | 18.96 | 19.01 | 18.86 | 18.57 | 0.0719 |
| 15 | 1 | 37 | | 18.87 | 18.88 | 18.64 | | |
| 15 | 1 | 74 | | 18.78 | 18.73 | 18.72 | | |
| 15 | 36 | 0 | | 17.05 | 17.09 | 16.90 | | |
| 15 | 36 | 20 | | 16.85 | 16.96 | 16.90 | | |
| 15 | 36 | 39 | | 16.92 | 16.90 | 16.91 | | |
| 15 | 75 | 0 | | 16.82 | 16.98 | 16.91 | | |
| Limit | EIRP < 2W | | | Result | | | Pass | |



| LTE Band 41 Maximum Average Power [dBm] (GT - LC = -0.44 dB) | | | | | | | | |
|--|-----------|-----------|---------|--------|--------|---------|------------|----------|
| BW [MHz] | RB Size | RB Offset | Mod | Lowest | Middle | Highest | EIRP (dBm) | EIRP (W) |
| 10 | 1 | 0 | QPSK | 23.95 | 24.05 | 23.97 | 23.61 | 0.2296 |
| 10 | 1 | 25 | | 23.96 | 24.01 | 23.94 | | |
| 10 | 1 | 49 | | 24.02 | 23.83 | 23.95 | | |
| 10 | 25 | 0 | | 23.00 | 23.02 | 22.88 | | |
| 10 | 25 | 12 | | 23.09 | 22.95 | 22.92 | | |
| 10 | 25 | 25 | | 23.02 | 23.00 | 22.83 | | |
| 10 | 50 | 0 | | 23.04 | 22.83 | 22.93 | | |
| 10 | 1 | 0 | 16-QAM | 22.98 | 22.95 | 22.93 | 22.64 | 0.1837 |
| 10 | 1 | 25 | | 22.93 | 22.88 | 23.08 | | |
| 10 | 1 | 49 | | 23.02 | 22.91 | 22.98 | | |
| 10 | 25 | 0 | | 21.91 | 21.85 | 22.00 | | |
| 10 | 25 | 12 | | 22.00 | 21.97 | 22.00 | | |
| 10 | 25 | 25 | | 21.87 | 22.04 | 21.97 | | |
| 10 | 50 | 0 | | 21.94 | 21.92 | 22.01 | | |
| 10 | 1 | 0 | 64-QAM | 21.57 | 21.67 | 21.56 | 21.23 | 0.1327 |
| 10 | 1 | 25 | | 21.51 | 21.42 | 21.42 | | |
| 10 | 1 | 49 | | 21.66 | 21.45 | 21.42 | | |
| 10 | 25 | 0 | | 21.07 | 20.98 | 21.09 | | |
| 10 | 25 | 12 | | 20.97 | 21.03 | 21.08 | | |
| 10 | 25 | 25 | | 21.00 | 20.98 | 20.90 | | |
| 10 | 50 | 0 | | 21.06 | 21.05 | 21.03 | | |
| 10 | 1 | 0 | 256-QAM | 18.92 | 19.08 | 18.97 | 18.64 | 0.0731 |
| 10 | 1 | 25 | | 18.86 | 18.89 | 18.64 | | |
| 10 | 1 | 49 | | 18.71 | 18.91 | 18.62 | | |
| 10 | 25 | 0 | | 16.99 | 17.06 | 16.92 | | |
| 10 | 25 | 12 | | 16.79 | 17.07 | 16.83 | | |
| 10 | 25 | 25 | | 16.88 | 16.87 | 16.86 | | |
| 10 | 50 | 0 | | 16.87 | 17.04 | 16.90 | | |
| Limit | EIRP < 2W | | | Result | | | Pass | |



| LTE Band 41 Maximum Average Power [dBm] (GT - LC = -0.44 dB) | | | | | | | | |
|--|-----------|-----------|---------|--------|--------|---------|------------|----------|
| BW [MHz] | RB Size | RB Offset | Mod | Lowest | Middle | Highest | EIRP (dBm) | EIRP (W) |
| 5 | 1 | 0 | QPSK | 24.01 | 24.02 | 24.05 | 23.61 | 0.2296 |
| 5 | 1 | 12 | | 23.84 | 23.91 | 23.93 | | |
| 5 | 1 | 24 | | 23.86 | 23.99 | 23.86 | | |
| 5 | 12 | 0 | | 22.91 | 22.92 | 22.96 | | |
| 5 | 12 | 7 | | 23.04 | 22.87 | 22.85 | | |
| 5 | 12 | 13 | | 22.97 | 22.91 | 22.95 | | |
| 5 | 25 | 0 | | 22.92 | 22.84 | 23.03 | | |
| 5 | 1 | 0 | 16-QAM | 22.96 | 22.98 | 22.98 | 22.65 | 0.1841 |
| 5 | 1 | 12 | | 22.94 | 23.00 | 23.09 | | |
| 5 | 1 | 24 | | 23.06 | 22.91 | 23.08 | | |
| 5 | 12 | 0 | | 21.88 | 22.03 | 22.01 | | |
| 5 | 12 | 7 | | 22.05 | 22.06 | 21.97 | | |
| 5 | 12 | 13 | | 22.04 | 21.98 | 21.86 | | |
| 5 | 25 | 0 | | 21.93 | 21.98 | 21.98 | | |
| 5 | 1 | 0 | 64-QAM | 21.70 | 21.55 | 21.47 | 21.26 | 0.1337 |
| 5 | 1 | 12 | | 21.51 | 21.45 | 21.42 | | |
| 5 | 1 | 24 | | 21.56 | 21.41 | 21.55 | | |
| 5 | 12 | 0 | | 21.07 | 21.00 | 20.98 | | |
| 5 | 12 | 7 | | 21.05 | 20.91 | 21.06 | | |
| 5 | 12 | 13 | | 20.91 | 20.93 | 21.03 | | |
| 5 | 25 | 0 | | 21.02 | 20.98 | 21.02 | | |
| 5 | 1 | 0 | 256-QAM | 19.05 | 18.97 | 18.90 | 18.61 | 0.0726 |
| 5 | 1 | 12 | | 18.78 | 18.83 | 18.74 | | |
| 5 | 1 | 24 | | 18.63 | 18.85 | 18.79 | | |
| 5 | 12 | 0 | | 17.00 | 17.02 | 17.05 | | |
| 5 | 12 | 7 | | 16.84 | 17.04 | 16.91 | | |
| 5 | 12 | 13 | | 16.92 | 16.90 | 16.72 | | |
| 5 | 25 | 0 | | 16.97 | 16.95 | 16.85 | | |
| Limit | EIRP < 2W | | | Result | | | Pass | |



| LTE Band 41(HPUE) Maximum Average Power [dBm] (GT - LC = -0.44 dB) | | | | | | | | |
|--|-----------|-----------|---------|--------|--------|---------|------------|----------|
| BW [MHz] | RB Size | RB Offset | Mod | Lowest | Middle | Highest | EIRP (dBm) | EIRP (W) |
| 20 | 1 | 0 | QPSK | 25.95 | 25.91 | 25.99 | 25.55 | 0.3589 |
| 20 | 1 | 49 | | 25.95 | 25.89 | 25.93 | | |
| 20 | 1 | 99 | | 25.94 | 25.87 | 25.91 | | |
| 20 | 50 | 0 | | 25.02 | 24.99 | 25.09 | | |
| 20 | 50 | 24 | | 25.00 | 24.97 | 25.00 | | |
| 20 | 50 | 50 | | 25.01 | 24.94 | 25.00 | | |
| 20 | 100 | 0 | | 25.04 | 24.98 | 25.05 | | |
| 20 | 1 | 0 | 16-QAM | 25.49 | 25.35 | 25.42 | 25.07 | 0.3214 |
| 20 | 1 | 49 | | 25.40 | 25.09 | 25.35 | | |
| 20 | 1 | 99 | | 25.51 | 25.36 | 25.46 | | |
| 20 | 50 | 0 | | 24.05 | 23.99 | 24.02 | | |
| 20 | 50 | 24 | | 24.03 | 23.99 | 24.03 | | |
| 20 | 50 | 50 | | 24.10 | 23.97 | 24.05 | | |
| 20 | 100 | 0 | | 24.07 | 23.98 | 24.09 | | |
| 20 | 1 | 0 | 64-QAM | 24.19 | 24.26 | 24.11 | 23.96 | 0.2489 |
| 20 | 1 | 49 | | 24.40 | 24.14 | 24.27 | | |
| 20 | 1 | 99 | | 24.19 | 24.13 | 24.12 | | |
| 20 | 50 | 0 | | 23.06 | 23.02 | 23.05 | | |
| 20 | 50 | 24 | | 23.06 | 23.00 | 23.03 | | |
| 20 | 50 | 50 | | 23.09 | 23.01 | 23.04 | | |
| 20 | 100 | 0 | | 23.06 | 23.01 | 23.08 | | |
| 20 | 1 | 0 | 256-QAM | 21.32 | 21.42 | 21.25 | 20.98 | 0.1253 |
| 20 | 1 | 49 | | 20.94 | 21.13 | 20.93 | | |
| 20 | 1 | 99 | | 20.99 | 21.12 | 20.93 | | |
| 20 | 50 | 0 | | 19.04 | 19.16 | 18.91 | | |
| 20 | 50 | 24 | | 18.97 | 19.10 | 18.85 | | |
| 20 | 50 | 50 | | 18.91 | 19.01 | 18.83 | | |
| 20 | 100 | 0 | | 18.87 | 19.02 | 18.82 | | |
| Limit | EIRP < 2W | | | Result | | | Pass | |



| LTE Band 41(HPUE) Maximum Average Power [dBm] (GT - LC = -0.44 dB) | | | | | | | | |
|--|-----------|-----------|---------|--------|--------|---------|------------|----------|
| BW [MHz] | RB Size | RB Offset | Mod | Lowest | Middle | Highest | EIRP (dBm) | EIRP (W) |
| 15 | 1 | 0 | QPSK | 25.82 | 25.71 | 25.98 | 25.54 | 0.3581 |
| 15 | 1 | 37 | | 25.77 | 25.76 | 25.75 | | |
| 15 | 1 | 74 | | 25.93 | 25.67 | 25.81 | | |
| 15 | 36 | 0 | | 24.85 | 24.95 | 25.07 | | |
| 15 | 36 | 20 | | 24.97 | 24.84 | 24.80 | | |
| 15 | 36 | 39 | | 24.82 | 24.77 | 24.93 | | |
| 15 | 75 | 0 | | 24.85 | 24.89 | 25.05 | | |
| 15 | 1 | 0 | 16-QAM | 25.37 | 25.33 | 25.31 | 25.02 | 0.3177 |
| 15 | 1 | 37 | | 25.32 | 25.03 | 25.31 | | |
| 15 | 1 | 74 | | 25.46 | 25.20 | 25.37 | | |
| 15 | 36 | 0 | | 23.97 | 23.92 | 24.02 | | |
| 15 | 36 | 20 | | 23.94 | 23.99 | 23.95 | | |
| 15 | 36 | 39 | | 24.06 | 23.88 | 23.86 | | |
| 15 | 75 | 0 | | 23.89 | 23.80 | 23.99 | | |
| 15 | 1 | 0 | 64-QAM | 24.04 | 24.14 | 23.95 | 23.83 | 0.2415 |
| 15 | 1 | 37 | | 24.27 | 24.13 | 24.27 | | |
| 15 | 1 | 74 | | 24.17 | 24.09 | 24.08 | | |
| 15 | 36 | 0 | | 22.99 | 22.94 | 22.98 | | |
| 15 | 36 | 20 | | 22.96 | 22.91 | 23.00 | | |
| 15 | 36 | 39 | | 23.04 | 22.83 | 22.92 | | |
| 15 | 75 | 0 | | 22.96 | 22.82 | 22.99 | | |
| 15 | 1 | 0 | 256-QAM | 21.18 | 21.33 | 21.24 | 20.89 | 0.1227 |
| 15 | 1 | 37 | | 20.77 | 21.03 | 20.73 | | |
| 15 | 1 | 74 | | 20.92 | 20.94 | 20.76 | | |
| 15 | 36 | 0 | | 18.91 | 19.16 | 18.88 | | |
| 15 | 36 | 20 | | 18.85 | 18.94 | 18.70 | | |
| 15 | 36 | 39 | | 18.91 | 18.94 | 18.66 | | |
| 15 | 75 | 0 | | 18.74 | 18.85 | 18.65 | | |
| Limit | EIRP < 2W | | | Result | | | Pass | |



| LTE Band 41(HPUE) Maximum Average Power [dBm] (GT - LC = -0.44 dB) | | | | | | | | |
|--|-----------|-----------|---------|--------|--------|---------|------------|----------|
| BW [MHz] | RB Size | RB Offset | Mod | Lowest | Middle | Highest | EIRP (dBm) | EIRP (W) |
| 10 | 1 | 0 | QPSK | 25.93 | 25.86 | 25.82 | 25.49 | 0.3540 |
| 10 | 1 | 25 | | 25.84 | 25.81 | 25.74 | | |
| 10 | 1 | 49 | | 25.88 | 25.77 | 25.72 | | |
| 10 | 25 | 0 | | 24.85 | 24.96 | 24.98 | | |
| 10 | 25 | 12 | | 24.96 | 24.95 | 24.81 | | |
| 10 | 25 | 25 | | 24.81 | 24.94 | 24.96 | | |
| 10 | 50 | 0 | | 24.98 | 24.90 | 24.93 | | |
| 10 | 1 | 0 | 16-QAM | 25.40 | 25.18 | 25.25 | 25.04 | 0.3192 |
| 10 | 1 | 25 | | 25.35 | 24.89 | 25.25 | | |
| 10 | 1 | 49 | | 25.48 | 25.29 | 25.27 | | |
| 10 | 25 | 0 | | 24.01 | 23.86 | 23.85 | | |
| 10 | 25 | 12 | | 23.90 | 23.86 | 23.94 | | |
| 10 | 25 | 25 | | 23.98 | 23.94 | 23.89 | | |
| 10 | 50 | 0 | | 24.02 | 23.91 | 24.03 | | |
| 10 | 1 | 0 | 64-QAM | 24.02 | 24.15 | 24.04 | 23.90 | 0.2455 |
| 10 | 1 | 25 | | 24.34 | 23.97 | 24.12 | | |
| 10 | 1 | 49 | | 24.01 | 24.10 | 23.96 | | |
| 10 | 25 | 0 | | 22.99 | 22.93 | 23.02 | | |
| 10 | 25 | 12 | | 22.96 | 22.87 | 22.97 | | |
| 10 | 25 | 25 | | 23.07 | 22.90 | 23.00 | | |
| 10 | 50 | 0 | | 22.89 | 23.01 | 23.08 | | |
| 10 | 1 | 0 | 256-QAM | 21.21 | 21.31 | 21.11 | 20.87 | 0.1222 |
| 10 | 1 | 25 | | 20.74 | 21.00 | 20.73 | | |
| 10 | 1 | 49 | | 20.79 | 20.96 | 20.76 | | |
| 10 | 25 | 0 | | 18.94 | 18.99 | 18.88 | | |
| 10 | 25 | 12 | | 18.79 | 19.07 | 18.79 | | |
| 10 | 25 | 25 | | 18.75 | 18.81 | 18.79 | | |
| 10 | 50 | 0 | | 18.72 | 18.97 | 18.75 | | |
| Limit | EIRP < 2W | | | Result | | | Pass | |



| LTE Band 41(HPUE) Maximum Average Power [dBm] (GT - LC = -0.44 dB) | | | | | | | | |
|--|-----------|-----------|---------|--------|--------|---------|------------|----------|
| BW [MHz] | RB Size | RB Offset | Mod | Lowest | Middle | Highest | EIRP (dBm) | EIRP (W) |
| 5 | 1 | 0 | QPSK | 25.76 | 25.91 | 25.90 | 25.47 | 0.3524 |
| 5 | 1 | 12 | | 25.75 | 25.85 | 25.82 | | |
| 5 | 1 | 24 | | 25.81 | 25.77 | 25.87 | | |
| 5 | 12 | 0 | | 24.96 | 24.79 | 25.04 | | |
| 5 | 12 | 7 | | 24.83 | 24.90 | 24.95 | | |
| 5 | 12 | 13 | | 24.88 | 24.78 | 25.00 | | |
| 5 | 25 | 0 | | 24.84 | 24.96 | 24.91 | | |
| 5 | 1 | 0 | 16-QAM | 25.47 | 25.29 | 25.41 | 25.03 | 0.3184 |
| 5 | 1 | 12 | | 25.31 | 24.98 | 25.15 | | |
| 5 | 1 | 24 | | 25.35 | 25.28 | 25.31 | | |
| 5 | 12 | 0 | | 23.87 | 23.84 | 23.93 | | |
| 5 | 12 | 7 | | 23.91 | 23.95 | 23.93 | | |
| 5 | 12 | 13 | | 24.08 | 23.83 | 23.97 | | |
| 5 | 25 | 0 | | 23.97 | 23.97 | 24.02 | | |
| 5 | 1 | 0 | 64-QAM | 24.17 | 24.21 | 24.06 | 23.79 | 0.2393 |
| 5 | 1 | 12 | | 24.23 | 23.97 | 24.09 | | |
| 5 | 1 | 24 | | 24.05 | 24.13 | 23.98 | | |
| 5 | 12 | 0 | | 23.03 | 22.96 | 22.87 | | |
| 5 | 12 | 7 | | 23.04 | 22.81 | 22.98 | | |
| 5 | 12 | 13 | | 23.08 | 22.85 | 22.98 | | |
| 5 | 25 | 0 | | 22.90 | 22.91 | 23.08 | | |
| 5 | 1 | 0 | 256-QAM | 21.17 | 21.40 | 21.07 | 20.96 | 0.1247 |
| 5 | 1 | 12 | | 20.89 | 20.99 | 20.80 | | |
| 5 | 1 | 24 | | 20.97 | 20.97 | 20.73 | | |
| 5 | 12 | 0 | | 18.88 | 18.97 | 18.88 | | |
| 5 | 12 | 7 | | 18.87 | 18.99 | 18.83 | | |
| 5 | 12 | 13 | | 18.78 | 18.93 | 18.67 | | |
| 5 | 25 | 0 | | 18.80 | 18.93 | 18.76 | | |
| Limit | EIRP < 2W | | | Result | | | Pass | |



| LTE Band 30 Maximum Average Power [dBm] (GT - LC = -2.43 dB) | | | | | | | | |
|--|-------------------|-----------|---------|--------|--------|---------|------------|----------|
| BW [MHz] | RB Size | RB Offset | Mod | Lowest | Middle | Highest | EIRP (dBm) | EIRP (W) |
| 10 | 1 | 0 | QPSK | | 22.49 | | 20.06 | 0.1014 |
| 10 | 1 | 25 | | | 22.33 | | | |
| 10 | 1 | 49 | | | 22.28 | | | |
| 10 | 25 | 0 | | | 21.38 | | | |
| 10 | 25 | 12 | | | 21.37 | | | |
| 10 | 25 | 25 | | | 21.36 | | | |
| 10 | 50 | 0 | | | 21.34 | | | |
| 10 | 1 | 0 | 16-QAM | | 21.72 | | 19.29 | 0.0849 |
| 10 | 1 | 25 | | | 21.65 | | | |
| 10 | 1 | 49 | | | 21.53 | | | |
| 10 | 25 | 0 | | | 20.39 | | | |
| 10 | 25 | 12 | | | 20.39 | | | |
| 10 | 25 | 25 | | | 20.35 | | | |
| 10 | 50 | 0 | | | 20.34 | | | |
| 10 | 1 | 0 | 64-QAM | - | 20.61 | - | 18.18 | 0.0658 |
| 10 | 1 | 25 | | | 20.46 | | | |
| 10 | 1 | 49 | | | 20.50 | | | |
| 10 | 25 | 0 | | | 19.40 | | | |
| 10 | 25 | 12 | | | 19.37 | | | |
| 10 | 25 | 25 | | | 19.33 | | | |
| 10 | 50 | 0 | | | 19.37 | | | |
| 10 | 1 | 0 | 256-QAM | | 17.56 | | 15.13 | 0.0326 |
| 10 | 1 | 25 | | | 17.38 | | | |
| 10 | 1 | 49 | | | 17.35 | | | |
| 10 | 25 | 0 | | | 17.40 | | | |
| 10 | 25 | 12 | | | 17.37 | | | |
| 10 | 25 | 25 | | | 17.35 | | | |
| 10 | 50 | 0 | | | 17.38 | | | |
| Limit | EIRP < 250mW/5MHz | | | Result | | | Pass | |

Total EIRP power is less than partial EIRP limit 250 mW/5MHz.



| LTE Band 30 Maximum Average Power [dBm] (GT - LC = -2.43 dB) | | | | | | | | |
|--|-------------------|-----------|---------|--------|--------|---------|------------|----------|
| BW [MHz] | RB Size | RB Offset | Mod | Lowest | Middle | Highest | EIRP (dBm) | EIRP (W) |
| 5 | 1 | 0 | QPSK | 22.45 | 22.32 | 22.44 | 20.02 | 0.1005 |
| 5 | 1 | 12 | | 22.15 | 22.15 | 22.14 | | |
| 5 | 1 | 24 | | 22.18 | 22.21 | 22.10 | | |
| 5 | 12 | 0 | | 21.20 | 21.22 | 21.30 | | |
| 5 | 12 | 7 | | 21.26 | 21.19 | 21.30 | | |
| 5 | 12 | 13 | | 21.21 | 21.32 | 21.22 | | |
| 5 | 25 | 0 | | 21.34 | 21.32 | 21.19 | | |
| 5 | 1 | 0 | 16-QAM | 21.55 | 21.63 | 21.70 | 19.27 | 0.0845 |
| 5 | 1 | 12 | | 21.65 | 21.58 | 21.64 | | |
| 5 | 1 | 24 | | 21.36 | 21.53 | 21.47 | | |
| 5 | 12 | 0 | | 20.23 | 20.32 | 20.20 | | |
| 5 | 12 | 7 | | 20.25 | 20.33 | 20.37 | | |
| 5 | 12 | 13 | | 20.26 | 20.21 | 20.34 | | |
| 5 | 25 | 0 | | 20.27 | 20.29 | 20.24 | | |
| 5 | 1 | 0 | 64-QAM | 20.49 | 20.46 | 20.46 | 18.06 | 0.0640 |
| 5 | 1 | 12 | | 20.34 | 20.38 | 20.35 | | |
| 5 | 1 | 24 | | 20.46 | 20.49 | 20.38 | | |
| 5 | 12 | 0 | | 19.27 | 19.38 | 19.35 | | |
| 5 | 12 | 7 | | 19.17 | 19.21 | 19.37 | | |
| 5 | 12 | 13 | | 19.19 | 19.15 | 19.26 | | |
| 5 | 25 | 0 | | 19.26 | 19.20 | 19.24 | | |
| 5 | 1 | 0 | 256-QAM | 17.53 | 17.40 | 17.53 | 15.10 | 0.0324 |
| 5 | 1 | 12 | | 17.34 | 17.35 | 17.30 | | |
| 5 | 1 | 24 | | 17.16 | 17.16 | 17.22 | | |
| 5 | 12 | 0 | | 17.21 | 17.35 | 17.23 | | |
| 5 | 12 | 7 | | 17.18 | 17.26 | 17.20 | | |
| 5 | 12 | 13 | | 17.33 | 17.24 | 17.17 | | |
| 5 | 25 | 0 | | 17.25 | 17.22 | 17.25 | | |
| Limit | EIRP < 250mW/5MHz | | | Result | | | Pass | |

Total EIRP power is less than partial EIRP limit 250 mW/5MHz.



| LTE Band 66 Maximum Average Power [dBm] (GT - LC = -1.78 dB) | | | | | | | | |
|--|-----------|-----------|---------|--------|--------|---------|------------|----------|
| BW [MHz] | RB Size | RB Offset | Mod | Lowest | Middle | Highest | EIRP (dBm) | EIRP (W) |
| 20 | 1 | 0 | QPSK | 24.75 | 24.82 | 24.78 | 23.04 | 0.2014 |
| 20 | 1 | 49 | | 24.64 | 24.69 | 24.50 | | |
| 20 | 1 | 99 | | 24.73 | 24.44 | 24.19 | | |
| 20 | 50 | 0 | | 23.64 | 23.69 | 23.60 | | |
| 20 | 50 | 24 | | 23.61 | 23.61 | 23.45 | | |
| 20 | 50 | 50 | | 23.57 | 23.53 | 23.30 | | |
| 20 | 100 | 0 | | 23.59 | 23.66 | 23.44 | | |
| 20 | 1 | 0 | 16-QAM | 23.79 | 23.96 | 23.99 | 22.21 | 0.1663 |
| 20 | 1 | 49 | | 23.66 | 23.88 | 23.69 | | |
| 20 | 1 | 99 | | 23.87 | 23.68 | 23.40 | | |
| 20 | 50 | 0 | | 22.56 | 22.68 | 22.57 | | |
| 20 | 50 | 24 | | 22.59 | 22.65 | 22.46 | | |
| 20 | 50 | 50 | | 22.59 | 22.55 | 22.31 | | |
| 20 | 100 | 0 | | 22.58 | 22.57 | 22.44 | | |
| 20 | 1 | 0 | 64-QAM | 22.55 | 22.84 | 22.91 | 21.13 | 0.1297 |
| 20 | 1 | 49 | | 22.65 | 22.77 | 22.67 | | |
| 20 | 1 | 99 | | 22.66 | 22.65 | 22.45 | | |
| 20 | 50 | 0 | | 21.57 | 21.69 | 21.60 | | |
| 20 | 50 | 24 | | 21.61 | 21.66 | 21.47 | | |
| 20 | 50 | 50 | | 21.61 | 21.57 | 21.32 | | |
| 20 | 100 | 0 | | 21.59 | 21.59 | 21.44 | | |
| 20 | 1 | 0 | 256-QAM | 19.55 | 19.73 | 19.79 | 18.01 | 0.0632 |
| 20 | 1 | 49 | | 19.36 | 19.64 | 19.66 | | |
| 20 | 1 | 99 | | 19.45 | 19.63 | 19.65 | | |
| 20 | 50 | 0 | | 19.22 | 19.42 | 19.46 | | |
| 20 | 50 | 24 | | 19.26 | 19.46 | 19.45 | | |
| 20 | 50 | 50 | | 19.23 | 19.43 | 19.42 | | |
| 20 | 100 | 0 | | 19.17 | 19.45 | 19.44 | | |
| Limit | EIRP < 1W | | | Result | | | Pass | |



| LTE Band 66 Maximum Average Power [dBm] (GT - LC = -1.78 dB) | | | | | | | | |
|--|-----------|-----------|---------|--------|--------|---------|------------|----------|
| BW [MHz] | RB Size | RB Offset | Mod | Lowest | Middle | Highest | EIRP (dBm) | EIRP (W) |
| 15 | 1 | 0 | QPSK | 24.57 | 24.70 | 24.62 | 22.92 | 0.1959 |
| 15 | 1 | 37 | | 24.61 | 24.51 | 24.44 | | |
| 15 | 1 | 74 | | 24.67 | 24.28 | 24.09 | | |
| 15 | 36 | 0 | | 23.63 | 23.66 | 23.42 | | |
| 15 | 36 | 20 | | 23.57 | 23.51 | 23.26 | | |
| 15 | 36 | 39 | | 23.50 | 23.48 | 23.10 | | |
| 15 | 75 | 0 | | 23.42 | 23.52 | 23.28 | | |
| 15 | 1 | 0 | 16-QAM | 23.61 | 23.88 | 23.93 | 22.15 | 0.1641 |
| 15 | 1 | 37 | | 23.60 | 23.83 | 23.65 | | |
| 15 | 1 | 74 | | 23.69 | 23.55 | 23.31 | | |
| 15 | 36 | 0 | | 22.40 | 22.61 | 22.53 | | |
| 15 | 36 | 20 | | 22.48 | 22.48 | 22.30 | | |
| 15 | 36 | 39 | | 22.43 | 22.53 | 22.29 | | |
| 15 | 75 | 0 | | 22.41 | 22.53 | 22.26 | | |
| 15 | 1 | 0 | 64-QAM | 22.52 | 22.70 | 22.72 | 20.98 | 0.1253 |
| 15 | 1 | 37 | | 22.45 | 22.76 | 22.52 | | |
| 15 | 1 | 74 | | 22.50 | 22.60 | 22.40 | | |
| 15 | 36 | 0 | | 21.41 | 21.61 | 21.50 | | |
| 15 | 36 | 20 | | 21.49 | 21.54 | 21.43 | | |
| 15 | 36 | 39 | | 21.48 | 21.54 | 21.26 | | |
| 15 | 75 | 0 | | 21.50 | 21.54 | 21.41 | | |
| 15 | 1 | 0 | 256-QAM | 19.47 | 19.59 | 19.60 | 17.87 | 0.0612 |
| 15 | 1 | 37 | | 19.19 | 19.51 | 19.47 | | |
| 15 | 1 | 74 | | 19.34 | 19.56 | 19.65 | | |
| 15 | 36 | 0 | | 19.08 | 19.38 | 19.33 | | |
| 15 | 36 | 20 | | 19.12 | 19.32 | 19.44 | | |
| 15 | 36 | 39 | | 19.23 | 19.34 | 19.33 | | |
| 15 | 75 | 0 | | 19.01 | 19.42 | 19.25 | | |
| Limit | EIRP < 1W | | | Result | | | Pass | |



| LTE Band 66 Maximum Average Power [dBm] (GT - LC = -1.78 dB) | | | | | | | | |
|--|-----------|-----------|---------|--------|--------|---------|------------|----------|
| BW [MHz] | RB Size | RB Offset | Mod | Lowest | Middle | Highest | EIRP (dBm) | EIRP (W) |
| 10 | 1 | 0 | QPSK | 24.74 | 24.75 | 24.73 | 22.97 | 0.1982 |
| 10 | 1 | 25 | | 24.55 | 24.58 | 24.50 | | |
| 10 | 1 | 49 | | 24.66 | 24.33 | 24.10 | | |
| 10 | 25 | 0 | | 23.54 | 23.54 | 23.42 | | |
| 10 | 25 | 12 | | 23.53 | 23.51 | 23.39 | | |
| 10 | 25 | 25 | | 23.40 | 23.33 | 23.23 | | |
| 10 | 50 | 0 | | 23.58 | 23.62 | 23.35 | | |
| 10 | 1 | 0 | 16-QAM | 23.78 | 23.93 | 23.82 | 22.15 | 0.1641 |
| 10 | 1 | 25 | | 23.58 | 23.88 | 23.49 | | |
| 10 | 1 | 49 | | 23.83 | 23.62 | 23.26 | | |
| 10 | 25 | 0 | | 22.44 | 22.56 | 22.44 | | |
| 10 | 25 | 12 | | 22.57 | 22.47 | 22.43 | | |
| 10 | 25 | 25 | | 22.55 | 22.51 | 22.19 | | |
| 10 | 50 | 0 | | 22.51 | 22.50 | 22.27 | | |
| 10 | 1 | 0 | 64-QAM | 22.46 | 22.80 | 22.86 | 21.08 | 0.1282 |
| 10 | 1 | 25 | | 22.58 | 22.72 | 22.52 | | |
| 10 | 1 | 49 | | 22.59 | 22.46 | 22.32 | | |
| 10 | 25 | 0 | | 21.46 | 21.51 | 21.41 | | |
| 10 | 25 | 12 | | 21.45 | 21.64 | 21.41 | | |
| 10 | 25 | 25 | | 21.48 | 21.41 | 21.21 | | |
| 10 | 50 | 0 | | 21.57 | 21.49 | 21.27 | | |
| 10 | 1 | 0 | 256-QAM | 19.38 | 19.56 | 19.76 | 17.98 | 0.0628 |
| 10 | 1 | 25 | | 19.28 | 19.61 | 19.64 | | |
| 10 | 1 | 49 | | 19.41 | 19.53 | 19.45 | | |
| 10 | 25 | 0 | | 19.08 | 19.22 | 19.40 | | |
| 10 | 25 | 12 | | 19.24 | 19.46 | 19.41 | | |
| 10 | 25 | 25 | | 19.22 | 19.25 | 19.39 | | |
| 10 | 50 | 0 | | 19.07 | 19.37 | 19.25 | | |
| Limit | EIRP < 1W | | | Result | | | Pass | |



| LTE Band 66 Maximum Average Power [dBm] (GT - LC = -1.78 dB) | | | | | | | | |
|--|-----------|-----------|---------|--------|--------|---------|------------|----------|
| BW [MHz] | RB Size | RB Offset | Mod | Lowest | Middle | Highest | EIRP (dBm) | EIRP (W) |
| 5 | 1 | 0 | QPSK | 24.75 | 24.74 | 24.58 | 22.97 | 0.1982 |
| 5 | 1 | 12 | | 24.49 | 24.63 | 24.39 | | |
| 5 | 1 | 24 | | 24.64 | 24.32 | 23.99 | | |
| 5 | 12 | 0 | | 23.58 | 23.59 | 23.48 | | |
| 5 | 12 | 7 | | 23.51 | 23.45 | 23.43 | | |
| 5 | 12 | 13 | | 23.53 | 23.48 | 23.27 | | |
| 5 | 25 | 0 | | 23.59 | 23.59 | 23.41 | | |
| 5 | 1 | 0 | 16-QAM | 23.61 | 23.80 | 23.85 | 22.07 | 0.1611 |
| 5 | 1 | 12 | | 23.62 | 23.72 | 23.69 | | |
| 5 | 1 | 24 | | 23.78 | 23.68 | 23.20 | | |
| 5 | 12 | 0 | | 22.53 | 22.65 | 22.46 | | |
| 5 | 12 | 7 | | 22.44 | 22.60 | 22.46 | | |
| 5 | 12 | 13 | | 22.57 | 22.37 | 22.15 | | |
| 5 | 25 | 0 | | 22.41 | 22.48 | 22.26 | | |
| 5 | 1 | 0 | 64-QAM | 22.38 | 22.70 | 22.83 | 21.05 | 0.1274 |
| 5 | 1 | 12 | | 22.45 | 22.65 | 22.64 | | |
| 5 | 1 | 24 | | 22.47 | 22.62 | 22.41 | | |
| 5 | 12 | 0 | | 21.55 | 21.57 | 21.45 | | |
| 5 | 12 | 7 | | 21.54 | 21.52 | 21.40 | | |
| 5 | 12 | 13 | | 21.42 | 21.54 | 21.21 | | |
| 5 | 25 | 0 | | 21.52 | 21.48 | 21.40 | | |
| 5 | 1 | 0 | 256-QAM | 19.38 | 19.65 | 19.75 | 17.97 | 0.0627 |
| 5 | 1 | 12 | | 19.20 | 19.46 | 19.49 | | |
| 5 | 1 | 24 | | 19.33 | 19.59 | 19.64 | | |
| 5 | 12 | 0 | | 19.13 | 19.35 | 19.39 | | |
| 5 | 12 | 7 | | 19.12 | 19.31 | 19.37 | | |
| 5 | 12 | 13 | | 19.21 | 19.39 | 19.37 | | |
| 5 | 25 | 0 | | 19.16 | 19.44 | 19.38 | | |
| Limit | EIRP < 1W | | | Result | | | Pass | |



| LTE Band 66 Maximum Average Power [dBm] (GT - LC = -1.78 dB) | | | | | | | | |
|--|-----------|-----------|---------|--------|--------|---------|------------|----------|
| BW [MHz] | RB Size | RB Offset | Mod | Lowest | Middle | Highest | EIRP (dBm) | EIRP (W) |
| 3 | 1 | 0 | QPSK | 24.70 | 24.64 | 24.72 | 22.94 | 0.1968 |
| 3 | 1 | 8 | | 24.56 | 24.69 | 24.44 | | |
| 3 | 1 | 14 | | 24.66 | 24.27 | 24.07 | | |
| 3 | 8 | 0 | | 23.58 | 23.60 | 23.48 | | |
| 3 | 8 | 4 | | 23.61 | 23.53 | 23.38 | | |
| 3 | 8 | 7 | | 23.39 | 23.41 | 23.11 | | |
| 3 | 15 | 0 | | 23.39 | 23.66 | 23.33 | | |
| 3 | 1 | 0 | 16-QAM | 23.74 | 23.87 | 23.86 | 22.09 | 0.1618 |
| 3 | 1 | 8 | | 23.52 | 23.71 | 23.51 | | |
| 3 | 1 | 14 | | 23.85 | 23.50 | 23.20 | | |
| 3 | 8 | 0 | | 22.50 | 22.52 | 22.39 | | |
| 3 | 8 | 4 | | 22.51 | 22.49 | 22.26 | | |
| 3 | 8 | 7 | | 22.59 | 22.48 | 22.31 | | |
| 3 | 15 | 0 | | 22.56 | 22.51 | 22.26 | | |
| 3 | 1 | 0 | 64-QAM | 22.47 | 22.82 | 22.73 | 21.04 | 0.1271 |
| 3 | 1 | 8 | | 22.62 | 22.58 | 22.67 | | |
| 3 | 1 | 14 | | 22.64 | 22.48 | 22.43 | | |
| 3 | 8 | 0 | | 21.40 | 21.62 | 21.51 | | |
| 3 | 8 | 4 | | 21.59 | 21.58 | 21.41 | | |
| 3 | 8 | 7 | | 21.48 | 21.38 | 21.12 | | |
| 3 | 15 | 0 | | 21.41 | 21.39 | 21.40 | | |
| 3 | 1 | 0 | 256-QAM | 19.54 | 19.62 | 19.70 | 17.92 | 0.0619 |
| 3 | 1 | 8 | | 19.27 | 19.62 | 19.62 | | |
| 3 | 1 | 14 | | 19.27 | 19.58 | 19.53 | | |
| 3 | 8 | 0 | | 19.02 | 19.40 | 19.37 | | |
| 3 | 8 | 4 | | 19.09 | 19.38 | 19.45 | | |
| 3 | 8 | 7 | | 19.08 | 19.25 | 19.28 | | |
| 3 | 15 | 0 | | 19.11 | 19.43 | 19.28 | | |
| Limit | EIRP < 1W | | | Result | | | Pass | |



| LTE Band 66 Maximum Average Power [dBm] (GT - LC = -1.78 dB) | | | | | | | | |
|--|-----------|-----------|---------|--------|--------|---------|------------|----------|
| BW [MHz] | RB Size | RB Offset | Mod | Lowest | Middle | Highest | EIRP (dBm) | EIRP (W) |
| 1.4 | 1 | 0 | QPSK | 24.63 | 24.77 | 24.74 | 23.03 | 0.2009 |
| 1.4 | 1 | 3 | | 24.50 | 24.49 | 24.33 | | |
| 1.4 | 1 | 5 | | 24.58 | 24.39 | 24.19 | | |
| 1.4 | 3 | 0 | | 24.66 | 24.81 | 24.71 | | |
| 1.4 | 3 | 1 | | 24.52 | 24.54 | 24.38 | | |
| 1.4 | 3 | 3 | | 24.58 | 24.38 | 24.01 | | |
| 1.4 | 6 | 0 | | 23.64 | 23.62 | 23.60 | | |
| 1.4 | 1 | 0 | 16-QAM | 23.52 | 23.48 | 23.43 | 22.10 | 0.1622 |
| 1.4 | 1 | 3 | | 23.40 | 23.53 | 23.19 | | |
| 1.4 | 1 | 5 | | 23.54 | 23.64 | 23.43 | | |
| 1.4 | 3 | 0 | | 23.69 | 23.83 | 23.88 | | |
| 1.4 | 3 | 1 | | 23.56 | 23.82 | 23.53 | | |
| 1.4 | 3 | 3 | | 23.84 | 23.68 | 23.31 | | |
| 1.4 | 6 | 0 | | 22.52 | 22.57 | 22.38 | | |
| 1.4 | 1 | 0 | 64-QAM | 22.59 | 22.47 | 22.27 | 21.07 | 0.1279 |
| 1.4 | 1 | 3 | | 22.46 | 22.49 | 22.13 | | |
| 1.4 | 1 | 5 | | 22.52 | 22.55 | 22.25 | | |
| 1.4 | 3 | 0 | | 22.52 | 22.70 | 22.85 | | |
| 1.4 | 3 | 1 | | 22.50 | 22.71 | 22.58 | | |
| 1.4 | 3 | 3 | | 22.52 | 22.53 | 22.37 | | |
| 1.4 | 6 | 0 | | 21.49 | 21.66 | 21.57 | | |
| 1.4 | 1 | 0 | 256-QAM | 19.51 | 19.54 | 19.67 | 17.89 | 0.0615 |
| 1.4 | 1 | 3 | | 19.17 | 19.49 | 19.51 | | |
| 1.4 | 1 | 5 | | 19.33 | 19.52 | 19.47 | | |
| 1.4 | 3 | 0 | | 19.18 | 19.25 | 19.34 | | |
| 1.4 | 3 | 1 | | 19.17 | 19.36 | 19.41 | | |
| 1.4 | 3 | 3 | | 19.22 | 19.34 | 19.41 | | |
| 1.4 | 6 | 0 | | 19.04 | 19.25 | 19.39 | | |
| Limit | EIRP < 1W | | | Result | | | Pass | |



| LTE Band 71 Maximum Average Power [dBm] (GT - LC = -4.51 dB) | | | | | | | | |
|--|----------|-----------|---------|--------|--------|---------|-----------|---------|
| BW [MHz] | RB Size | RB Offset | Mod | Lowest | Middle | Highest | ERP (dBm) | ERP (W) |
| 20 | 1 | 0 | QPSK | 24.59 | 24.70 | 24.63 | 18.04 | 0.0637 |
| 20 | 1 | 49 | | 24.48 | 24.53 | 24.49 | | |
| 20 | 1 | 99 | | 24.44 | 24.53 | 24.48 | | |
| 20 | 50 | 0 | | 23.61 | 23.59 | 23.56 | | |
| 20 | 50 | 24 | | 23.59 | 23.58 | 23.55 | | |
| 20 | 50 | 50 | | 23.54 | 23.55 | 23.55 | | |
| 20 | 100 | 0 | | 23.53 | 23.54 | 23.48 | | |
| 20 | 1 | 0 | 16-QAM | 24.14 | 24.03 | 23.92 | 17.48 | 0.0560 |
| 20 | 1 | 49 | | 24.07 | 23.82 | 23.90 | | |
| 20 | 1 | 99 | | 23.96 | 23.99 | 23.77 | | |
| 20 | 50 | 0 | | 22.61 | 22.62 | 22.57 | | |
| 20 | 50 | 24 | | 22.64 | 22.59 | 22.58 | | |
| 20 | 50 | 50 | | 22.59 | 22.57 | 22.57 | | |
| 20 | 100 | 0 | | 22.56 | 22.53 | 22.51 | | |
| 20 | 1 | 0 | 64-QAM | 22.95 | 22.87 | 22.79 | 16.29 | 0.0426 |
| 20 | 1 | 49 | | 22.75 | 22.61 | 22.77 | | |
| 20 | 1 | 99 | | 22.75 | 22.89 | 22.70 | | |
| 20 | 50 | 0 | | 21.65 | 21.67 | 21.62 | | |
| 20 | 50 | 24 | | 21.69 | 21.64 | 21.64 | | |
| 20 | 50 | 50 | | 21.65 | 21.61 | 21.62 | | |
| 20 | 100 | 0 | | 21.59 | 21.56 | 21.51 | | |
| 20 | 1 | 0 | 256-QAM | 19.91 | 19.84 | 19.87 | 13.25 | 0.0211 |
| 20 | 1 | 49 | | 19.55 | 19.56 | 19.56 | | |
| 20 | 1 | 99 | | 19.51 | 19.52 | 19.48 | | |
| 20 | 50 | 0 | | 19.50 | 19.49 | 19.44 | | |
| 20 | 50 | 24 | | 19.52 | 19.50 | 19.51 | | |
| 20 | 50 | 50 | | 19.52 | 19.53 | 19.53 | | |
| 20 | 100 | 0 | | 19.53 | 19.46 | 19.43 | | |
| Limit | ERP < 3W | | | Result | | | Pass | |



| LTE Band 71 Maximum Average Power [dBm] (GT - LC = -4.51 dB) | | | | | | | | |
|--|----------|-----------|---------|--------|--------|---------|-----------|---------|
| BW [MHz] | RB Size | RB Offset | Mod | Lowest | Middle | Highest | ERP (dBm) | ERP (W) |
| 15 | 1 | 0 | QPSK | 24.53 | 24.58 | 24.57 | 17.92 | 0.0619 |
| 15 | 1 | 37 | | 24.40 | 24.35 | 24.34 | | |
| 15 | 1 | 74 | | 24.24 | 24.38 | 24.42 | | |
| 15 | 36 | 0 | | 23.43 | 23.55 | 23.50 | | |
| 15 | 36 | 20 | | 23.51 | 23.42 | 23.51 | | |
| 15 | 36 | 39 | | 23.47 | 23.50 | 23.55 | | |
| 15 | 75 | 0 | | 23.38 | 23.53 | 23.37 | | |
| 15 | 1 | 0 | 16-QAM | 24.03 | 23.83 | 23.92 | 17.37 | 0.0546 |
| 15 | 1 | 37 | | 23.97 | 23.68 | 23.77 | | |
| 15 | 1 | 74 | | 23.82 | 23.97 | 23.77 | | |
| 15 | 36 | 0 | | 22.45 | 22.62 | 22.53 | | |
| 15 | 36 | 20 | | 22.48 | 22.39 | 22.41 | | |
| 15 | 36 | 39 | | 22.53 | 22.37 | 22.43 | | |
| 15 | 75 | 0 | | 22.48 | 22.49 | 22.34 | | |
| 15 | 1 | 0 | 64-QAM | 22.84 | 22.72 | 22.61 | 16.18 | 0.0415 |
| 15 | 1 | 37 | | 22.67 | 22.46 | 22.63 | | |
| 15 | 1 | 74 | | 22.55 | 22.71 | 22.65 | | |
| 15 | 36 | 0 | | 21.49 | 21.58 | 21.53 | | |
| 15 | 36 | 20 | | 21.57 | 21.46 | 21.48 | | |
| 15 | 36 | 39 | | 21.50 | 21.56 | 21.49 | | |
| 15 | 75 | 0 | | 21.45 | 21.44 | 21.39 | | |
| 15 | 1 | 0 | 256-QAM | 19.79 | 19.65 | 19.79 | 13.13 | 0.0206 |
| 15 | 1 | 37 | | 19.55 | 19.47 | 19.54 | | |
| 15 | 1 | 74 | | 19.51 | 19.41 | 19.38 | | |
| 15 | 36 | 0 | | 19.42 | 19.41 | 19.43 | | |
| 15 | 36 | 20 | | 19.39 | 19.43 | 19.32 | | |
| 15 | 36 | 39 | | 19.52 | 19.40 | 19.50 | | |
| 15 | 75 | 0 | | 19.36 | 19.44 | 19.34 | | |
| Limit | ERP < 3W | | | Result | | | Pass | |



| LTE Band 71 Maximum Average Power [dBm] (GT - LC = -4.51 dB) | | | | | | | | |
|--|----------|-----------|---------|--------|--------|---------|-----------|---------|
| BW [MHz] | RB Size | RB Offset | Mod | Lowest | Middle | Highest | ERP (dBm) | ERP (W) |
| 10 | 1 | 0 | QPSK | 24.45 | 24.69 | 24.52 | 18.03 | 0.0635 |
| 10 | 1 | 25 | | 24.35 | 24.40 | 24.31 | | |
| 10 | 1 | 49 | | 24.36 | 24.41 | 24.41 | | |
| 10 | 25 | 0 | | 23.41 | 23.46 | 23.36 | | |
| 10 | 25 | 12 | | 23.54 | 23.47 | 23.49 | | |
| 10 | 25 | 25 | | 23.52 | 23.36 | 23.48 | | |
| 10 | 50 | 0 | | 23.46 | 23.46 | 23.41 | | |
| 10 | 1 | 0 | 16-QAM | 24.00 | 24.01 | 23.82 | 17.35 | 0.0543 |
| 10 | 1 | 25 | | 23.87 | 23.79 | 23.81 | | |
| 10 | 1 | 49 | | 23.76 | 23.87 | 23.73 | | |
| 10 | 25 | 0 | | 22.52 | 22.46 | 22.42 | | |
| 10 | 25 | 12 | | 22.49 | 22.47 | 22.38 | | |
| 10 | 25 | 25 | | 22.51 | 22.39 | 22.43 | | |
| 10 | 50 | 0 | | 22.49 | 22.40 | 22.35 | | |
| 10 | 1 | 0 | 64-QAM | 22.92 | 22.78 | 22.77 | 16.26 | 0.0423 |
| 10 | 1 | 25 | | 22.73 | 22.54 | 22.59 | | |
| 10 | 1 | 49 | | 22.66 | 22.84 | 22.63 | | |
| 10 | 25 | 0 | | 21.58 | 21.61 | 21.50 | | |
| 10 | 25 | 12 | | 21.56 | 21.49 | 21.54 | | |
| 10 | 25 | 25 | | 21.47 | 21.57 | 21.54 | | |
| 10 | 50 | 0 | | 21.46 | 21.48 | 21.42 | | |
| 10 | 1 | 0 | 256-QAM | 19.87 | 19.71 | 19.67 | 13.21 | 0.0209 |
| 10 | 1 | 25 | | 19.35 | 19.49 | 19.54 | | |
| 10 | 1 | 49 | | 19.32 | 19.39 | 19.44 | | |
| 10 | 25 | 0 | | 19.36 | 19.35 | 19.30 | | |
| 10 | 25 | 12 | | 19.39 | 19.45 | 19.51 | | |
| 10 | 25 | 25 | | 19.37 | 19.50 | 19.33 | | |
| 10 | 50 | 0 | | 19.37 | 19.33 | 19.39 | | |
| Limit | ERP < 3W | | | Result | | | Pass | |



| LTE Band 71 Maximum Average Power [dBm] (GT - LC = -4.51 dB) | | | | | | | | |
|--|----------|-----------|---------|--------|--------|---------|-----------|---------|
| BW [MHz] | RB Size | RB Offset | Mod | Lowest | Middle | Highest | ERP (dBm) | ERP (W) |
| 5 | 1 | 0 | QPSK | 24.52 | 24.54 | 24.53 | 17.88 | 0.0614 |
| 5 | 1 | 12 | | 24.32 | 24.35 | 24.41 | | |
| 5 | 1 | 24 | | 24.28 | 24.37 | 24.38 | | |
| 5 | 12 | 0 | | 23.44 | 23.42 | 23.41 | | |
| 5 | 12 | 7 | | 23.55 | 23.41 | 23.54 | | |
| 5 | 12 | 13 | | 23.39 | 23.52 | 23.55 | | |
| 5 | 25 | 0 | | 23.38 | 23.54 | 23.32 | | |
| 5 | 1 | 0 | 16-QAM | 24.09 | 23.93 | 23.88 | 17.43 | 0.0553 |
| 5 | 1 | 12 | | 24.03 | 23.82 | 23.71 | | |
| 5 | 1 | 24 | | 23.96 | 23.80 | 23.66 | | |
| 5 | 12 | 0 | | 22.46 | 22.53 | 22.51 | | |
| 5 | 12 | 7 | | 22.58 | 22.51 | 22.50 | | |
| 5 | 12 | 13 | | 22.49 | 22.51 | 22.46 | | |
| 5 | 25 | 0 | | 22.45 | 22.41 | 22.35 | | |
| 5 | 1 | 0 | 64-QAM | 22.77 | 22.84 | 22.70 | 16.18 | 0.0415 |
| 5 | 1 | 12 | | 22.55 | 22.45 | 22.77 | | |
| 5 | 1 | 24 | | 22.72 | 22.74 | 22.58 | | |
| 5 | 12 | 0 | | 21.50 | 21.59 | 21.52 | | |
| 5 | 12 | 7 | | 21.57 | 21.58 | 21.46 | | |
| 5 | 12 | 13 | | 21.60 | 21.60 | 21.56 | | |
| 5 | 25 | 0 | | 21.43 | 21.49 | 21.34 | | |
| 5 | 1 | 0 | 256-QAM | 19.81 | 19.82 | 19.87 | 13.21 | 0.0209 |
| 5 | 1 | 12 | | 19.40 | 19.37 | 19.42 | | |
| 5 | 1 | 24 | | 19.38 | 19.41 | 19.34 | | |
| 5 | 12 | 0 | | 19.45 | 19.32 | 19.28 | | |
| 5 | 12 | 7 | | 19.41 | 19.37 | 19.50 | | |
| 5 | 12 | 13 | | 19.51 | 19.50 | 19.36 | | |
| 5 | 25 | 0 | | 19.48 | 19.41 | 19.34 | | |
| Limit | ERP < 3W | | | Result | | | Pass | |



| LTE Band 14 Maximum Average Power [dBm] (GT - LC = -5.48 dB) | | | | | | | | |
|--|----------|-----------|---------|--------|--------|---------|-----------|---------|
| BW [MHz] | RB Size | RB Offset | Mod | Lowest | Middle | Highest | ERP (dBm) | ERP (W) |
| 10 | 1 | 0 | QPSK | | 24.40 | | 16.77 | 0.0475 |
| 10 | 1 | 25 | | | 24.24 | | | |
| 10 | 1 | 49 | | | 24.26 | | | |
| 10 | 25 | 0 | | | 23.36 | | | |
| 10 | 25 | 12 | | | 23.33 | | | |
| 10 | 25 | 25 | | | 23.32 | | | |
| 10 | 50 | 0 | | | 23.36 | | | |
| 10 | 1 | 0 | 16-QAM | | 23.66 | | 16.03 | 0.0401 |
| 10 | 1 | 25 | | | 23.50 | | | |
| 10 | 1 | 49 | | | 23.57 | | | |
| 10 | 25 | 0 | | | 22.38 | | | |
| 10 | 25 | 12 | | | 22.34 | | | |
| 10 | 25 | 25 | | | 22.34 | | | |
| 10 | 50 | 0 | | | 22.34 | | | |
| 10 | 1 | 0 | 64-QAM | | 22.69 | | 15.06 | 0.0321 |
| 10 | 1 | 25 | | | 22.53 | | | |
| 10 | 1 | 49 | | | 22.55 | | | |
| 10 | 25 | 0 | | | 21.36 | | | |
| 10 | 25 | 12 | | | 21.35 | | | |
| 10 | 25 | 25 | | | 21.33 | | | |
| 10 | 50 | 0 | | | 21.36 | | | |
| 10 | 1 | 0 | 256-QAM | | 19.63 | | 12.00 | 0.0158 |
| 10 | 1 | 25 | | | 19.37 | | | |
| 10 | 1 | 49 | | | 19.44 | | | |
| 10 | 25 | 0 | | | 19.45 | | | |
| 10 | 25 | 12 | | | 19.32 | | | |
| 10 | 25 | 25 | | | 19.36 | | | |
| 10 | 50 | 0 | | | 19.38 | | | |
| Limit | ERP < 3W | | | Result | | | Pass | |



| LTE Band 14 Maximum Average Power [dBm] (GT - LC = -5.48 dB) | | | | | | | | |
|--|----------|-----------|---------|--------|--------|---------|-----------|---------|
| BW [MHz] | RB Size | RB Offset | Mod | Lowest | Middle | Highest | ERP (dBm) | ERP (W) |
| 5 | 1 | 0 | QPSK | 24.33 | 24.31 | 24.22 | 16.70 | 0.0468 |
| 5 | 1 | 12 | | 24.18 | 24.10 | 24.04 | | |
| 5 | 1 | 24 | | 24.21 | 24.17 | 24.19 | | |
| 5 | 12 | 0 | | 23.28 | 23.34 | 23.35 | | |
| 5 | 12 | 7 | | 23.27 | 23.16 | 23.15 | | |
| 5 | 12 | 13 | | 23.20 | 23.25 | 23.15 | | |
| 5 | 25 | 0 | | 23.21 | 23.19 | 23.33 | | |
| 5 | 1 | 0 | 16-QAM | 23.54 | 23.62 | 23.62 | 15.99 | 0.0397 |
| 5 | 1 | 12 | | 23.36 | 23.33 | 23.43 | | |
| 5 | 1 | 24 | | 23.53 | 23.43 | 23.51 | | |
| 5 | 12 | 0 | | 22.36 | 22.37 | 22.21 | | |
| 5 | 12 | 7 | | 22.21 | 22.20 | 22.19 | | |
| 5 | 12 | 13 | | 22.25 | 22.19 | 22.16 | | |
| 5 | 25 | 0 | | 22.31 | 22.17 | 22.20 | | |
| 5 | 1 | 0 | 64-QAM | 22.67 | 22.57 | 22.50 | 15.04 | 0.0319 |
| 5 | 1 | 12 | | 22.39 | 22.53 | 22.38 | | |
| 5 | 1 | 24 | | 22.38 | 22.52 | 22.48 | | |
| 5 | 12 | 0 | | 21.35 | 21.27 | 21.18 | | |
| 5 | 12 | 7 | | 21.33 | 21.29 | 21.26 | | |
| 5 | 12 | 13 | | 21.25 | 21.16 | 21.30 | | |
| 5 | 25 | 0 | | 21.18 | 21.29 | 21.25 | | |
| 5 | 1 | 0 | 256-QAM | 19.44 | 19.53 | 19.49 | 11.90 | 0.0155 |
| 5 | 1 | 12 | | 19.23 | 19.33 | 19.35 | | |
| 5 | 1 | 24 | | 19.36 | 19.34 | 19.39 | | |
| 5 | 12 | 0 | | 19.40 | 19.44 | 19.26 | | |
| 5 | 12 | 7 | | 19.20 | 19.14 | 19.16 | | |
| 5 | 12 | 13 | | 19.29 | 19.33 | 19.16 | | |
| 5 | 25 | 0 | | 19.18 | 19.36 | 19.28 | | |
| Limit | ERP < 3W | | | Result | | | Pass | |



| LTE Band 26(Part90S) Maximum Average Power [dBm] (GT - LC = -5.4 dB) | | | | | | | | |
|--|--------------|-----------|---------|--------|--------|---------|-----------|---------|
| BW [MHz] | RB Size | RB Offset | Mod | Lowest | Middle | Highest | ERP (dBm) | ERP (W) |
| 15 | 1 | 0 | QPSK | 24.49 | - | - | 16.94 | 0.0494 |
| 15 | 1 | 37 | | 24.33 | - | - | | |
| 15 | 1 | 74 | | 24.38 | - | - | | |
| 15 | 36 | 0 | | 23.46 | - | - | | |
| 15 | 36 | 20 | | 23.43 | - | - | | |
| 15 | 36 | 39 | | 23.41 | - | - | | |
| 15 | 75 | 0 | | 23.40 | - | - | | |
| 15 | 1 | 0 | 16-QAM | 23.80 | - | - | 16.28 | 0.0425 |
| 15 | 1 | 37 | | 23.75 | - | - | | |
| 15 | 1 | 74 | | 23.83 | - | - | | |
| 15 | 36 | 0 | | 22.47 | - | - | | |
| 15 | 36 | 20 | | 22.42 | - | - | | |
| 15 | 36 | 39 | | 22.43 | - | - | | |
| 15 | 75 | 0 | | 22.43 | - | - | | |
| 15 | 1 | 0 | 64-QAM | 22.69 | - | - | 15.14 | 0.0327 |
| 15 | 1 | 37 | | 22.65 | - | - | | |
| 15 | 1 | 74 | | 22.59 | - | - | | |
| 15 | 36 | 0 | | 21.49 | - | - | | |
| 15 | 36 | 20 | | 21.45 | - | - | | |
| 15 | 36 | 39 | | 21.44 | - | - | | |
| 15 | 75 | 0 | | 21.41 | - | - | | |
| 15 | 1 | 0 | 256-QAM | 19.71 | - | - | 12.16 | 0.0164 |
| 15 | 1 | 37 | | 19.33 | - | - | | |
| 15 | 1 | 74 | | 19.39 | - | - | | |
| 15 | 36 | 0 | | 19.31 | - | - | | |
| 15 | 36 | 20 | | 19.34 | - | - | | |
| 15 | 36 | 39 | | 19.32 | - | - | | |
| 15 | 75 | 0 | | 19.23 | - | - | | |
| Limit | Power < 100W | | | Result | | | Pass | |



| LTE Band 26(Part90S) Maximum Average Power [dBm] (GT - LC = -5.4 dB) | | | | | | | | |
|--|--------------|-----------|---------|--------|--------|---------|-----------|---------|
| BW [MHz] | RB Size | RB Offset | Mod | Lowest | Middle | Highest | ERP (dBm) | ERP (W) |
| 10 | 1 | 0 | QPSK | - | 24.47 | - | 16.92 | 0.0492 |
| 10 | 1 | 25 | | - | 24.07 | - | | |
| 10 | 1 | 49 | | - | 24.23 | - | | |
| 10 | 25 | 0 | | - | 23.40 | - | | |
| 10 | 25 | 12 | | - | 23.25 | - | | |
| 10 | 25 | 25 | | - | 23.38 | - | | |
| 10 | 50 | 0 | | - | 23.21 | - | | |
| 10 | 1 | 0 | 16-QAM | - | 23.63 | - | 16.12 | 0.0409 |
| 10 | 1 | 25 | | - | 23.67 | - | | |
| 10 | 1 | 49 | | - | 23.60 | - | | |
| 10 | 25 | 0 | | - | 22.22 | - | | |
| 10 | 25 | 12 | | - | 22.38 | - | | |
| 10 | 25 | 25 | | - | 22.18 | - | | |
| 10 | 50 | 0 | | - | 22.36 | - | | |
| 10 | 1 | 0 | 64-QAM | - | 22.42 | - | 14.88 | 0.0308 |
| 10 | 1 | 25 | | - | 22.43 | - | | |
| 10 | 1 | 49 | | - | 22.34 | - | | |
| 10 | 25 | 0 | | - | 21.34 | - | | |
| 10 | 25 | 12 | | - | 21.36 | - | | |
| 10 | 25 | 25 | | - | 21.25 | - | | |
| 10 | 50 | 0 | | - | 21.40 | - | | |
| 10 | 1 | 0 | 256-QAM | - | 19.54 | - | 11.99 | 0.0158 |
| 10 | 1 | 25 | | - | 19.31 | - | | |
| 10 | 1 | 49 | | - | 19.33 | - | | |
| 10 | 25 | 0 | | - | 19.27 | - | | |
| 10 | 25 | 12 | | - | 19.23 | - | | |
| 10 | 25 | 25 | | - | 19.28 | - | | |
| 10 | 50 | 0 | | - | 19.31 | - | | |
| Limit | Power < 100W | | | Result | | | Pass | |



| LTE Band 26(Part90S) Maximum Average Power [dBm] (GT - LC = -5.4 dB) | | | | | | | | |
|--|--------------|-----------|---------|--------|--------|---------|-----------|---------|
| BW [MHz] | RB Size | RB Offset | Mod | Lowest | Middle | Highest | ERP (dBm) | ERP (W) |
| 5 | 1 | 0 | QPSK | 24.39 | 24.40 | 24.48 | 16.93 | 0.0493 |
| 5 | 1 | 12 | | 24.26 | 24.19 | 24.21 | | |
| 5 | 1 | 24 | | 24.19 | 24.29 | 24.20 | | |
| 5 | 12 | 0 | | 23.28 | 23.33 | 23.28 | | |
| 5 | 12 | 7 | | 23.38 | 23.46 | 23.39 | | |
| 5 | 12 | 13 | | 23.30 | 23.38 | 23.37 | | |
| 5 | 25 | 0 | | 23.26 | 23.28 | 23.24 | | |
| 5 | 1 | 0 | 16-QAM | 23.60 | 23.59 | 23.56 | 16.23 | 0.0420 |
| 5 | 1 | 12 | | 23.75 | 23.66 | 23.66 | | |
| 5 | 1 | 24 | | 23.77 | 23.78 | 23.72 | | |
| 5 | 12 | 0 | | 22.35 | 22.41 | 22.27 | | |
| 5 | 12 | 7 | | 22.23 | 22.23 | 22.33 | | |
| 5 | 12 | 13 | | 22.34 | 22.36 | 22.36 | | |
| 5 | 25 | 0 | | 22.24 | 22.32 | 22.28 | | |
| 5 | 1 | 0 | 64-QAM | 22.57 | 22.57 | 22.65 | 15.10 | 0.0324 |
| 5 | 1 | 12 | | 22.56 | 22.51 | 22.51 | | |
| 5 | 1 | 24 | | 22.51 | 22.50 | 22.59 | | |
| 5 | 12 | 0 | | 21.43 | 21.42 | 21.43 | | |
| 5 | 12 | 7 | | 21.44 | 21.46 | 21.34 | | |
| 5 | 12 | 13 | | 21.39 | 21.36 | 21.48 | | |
| 5 | 25 | 0 | | 21.37 | 21.38 | 21.27 | | |
| 5 | 1 | 0 | 256-QAM | 19.57 | 19.65 | 19.65 | 12.10 | 0.0162 |
| 5 | 1 | 12 | | 19.23 | 19.21 | 19.28 | | |
| 5 | 1 | 24 | | 19.37 | 19.38 | 19.39 | | |
| 5 | 12 | 0 | | 19.31 | 19.33 | 19.37 | | |
| 5 | 12 | 7 | | 19.15 | 19.10 | 19.10 | | |
| 5 | 12 | 13 | | 19.30 | 19.21 | 19.36 | | |
| 5 | 25 | 0 | | 19.16 | 19.18 | 19.06 | | |
| Limit | Power < 100W | | | Result | | | Pass | |



| LTE Band 26(Part90S) Maximum Average Power [dBm] (GT - LC = -5.4 dB) | | | | | | | | |
|--|--------------|-----------|---------|--------|--------|---------|-----------|---------|
| BW [MHz] | RB Size | RB Offset | Mod | Lowest | Middle | Highest | ERP (dBm) | ERP (W) |
| 3 | 1 | 0 | QPSK | 24.46 | 24.37 | 24.37 | 16.91 | 0.0491 |
| 3 | 1 | 8 | | 24.18 | 24.15 | 24.22 | | |
| 3 | 1 | 14 | | 24.35 | 24.35 | 24.25 | | |
| 3 | 8 | 0 | | 23.27 | 23.33 | 23.18 | | |
| 3 | 8 | 4 | | 23.39 | 23.48 | 23.39 | | |
| 3 | 8 | 7 | | 23.21 | 23.16 | 23.22 | | |
| 3 | 15 | 0 | | 23.25 | 23.16 | 23.17 | | |
| 3 | 1 | 0 | 16-QAM | 23.66 | 23.65 | 23.65 | 16.19 | 0.0416 |
| 3 | 1 | 8 | | 23.66 | 23.58 | 23.67 | | |
| 3 | 1 | 14 | | 23.69 | 23.74 | 23.60 | | |
| 3 | 8 | 0 | | 22.33 | 22.30 | 22.24 | | |
| 3 | 8 | 4 | | 22.33 | 22.35 | 22.32 | | |
| 3 | 8 | 7 | | 22.23 | 22.16 | 22.18 | | |
| 3 | 15 | 0 | | 22.34 | 22.25 | 22.41 | | |
| 3 | 1 | 0 | 64-QAM | 22.67 | 22.62 | 22.61 | 15.12 | 0.0325 |
| 3 | 1 | 8 | | 22.52 | 22.55 | 22.48 | | |
| 3 | 1 | 14 | | 22.45 | 22.41 | 22.48 | | |
| 3 | 8 | 0 | | 21.43 | 21.44 | 21.49 | | |
| 3 | 8 | 4 | | 21.31 | 21.41 | 21.41 | | |
| 3 | 8 | 7 | | 21.41 | 21.48 | 21.41 | | |
| 3 | 15 | 0 | | 21.28 | 21.19 | 21.38 | | |
| 3 | 1 | 0 | 256-QAM | 19.63 | 19.59 | 19.57 | 12.08 | 0.0161 |
| 3 | 1 | 8 | | 19.25 | 19.21 | 19.33 | | |
| 3 | 1 | 14 | | 19.31 | 19.32 | 19.27 | | |
| 3 | 8 | 0 | | 19.26 | 19.29 | 19.31 | | |
| 3 | 8 | 4 | | 19.29 | 19.35 | 19.19 | | |
| 3 | 8 | 7 | | 19.12 | 19.11 | 19.14 | | |
| 3 | 15 | 0 | | 19.11 | 19.07 | 19.11 | | |
| Limit | Power < 100W | | | Result | | | Pass | |



| LTE Band 26(Part90S) Maximum Average Power [dBm] (GT - LC = -5.4 dB) | | | | | | | | |
|--|--------------|-----------|---------|--------|--------|---------|-----------|---------|
| BW [MHz] | RB Size | RB Offset | Mod | Lowest | Middle | Highest | ERP (dBm) | ERP (W) |
| 1.4 | 1 | 0 | QPSK | 24.36 | 24.42 | 24.40 | 16.87 | 0.0486 |
| 1.4 | 1 | 3 | | 24.16 | 24.24 | 24.08 | | |
| 1.4 | 1 | 5 | | 24.29 | 24.34 | 24.30 | | |
| 1.4 | 3 | 0 | | 24.37 | 24.42 | 24.28 | | |
| 1.4 | 3 | 1 | | 24.30 | 24.23 | 24.24 | | |
| 1.4 | 3 | 3 | | 24.22 | 24.17 | 24.12 | | |
| 1.4 | 6 | 0 | | 23.37 | 23.37 | 23.37 | | |
| 1.4 | 1 | 0 | 16-QAM | 23.25 | 23.23 | 23.17 | 16.24 | 0.0421 |
| 1.4 | 1 | 3 | | 23.31 | 23.22 | 23.34 | | |
| 1.4 | 1 | 5 | | 23.33 | 23.39 | 23.26 | | |
| 1.4 | 3 | 0 | | 23.77 | 23.71 | 23.79 | | |
| 1.4 | 3 | 1 | | 23.64 | 23.70 | 23.74 | | |
| 1.4 | 3 | 3 | | 23.70 | 23.61 | 23.64 | | |
| 1.4 | 6 | 0 | | 22.27 | 22.17 | 22.27 | | |
| 1.4 | 1 | 0 | 64-QAM | 22.37 | 22.37 | 22.47 | 15.18 | 0.0330 |
| 1.4 | 1 | 3 | | 22.27 | 22.36 | 22.37 | | |
| 1.4 | 1 | 5 | | 22.24 | 22.25 | 22.28 | | |
| 1.4 | 3 | 0 | | 22.68 | 22.73 | 22.61 | | |
| 1.4 | 3 | 1 | | 22.49 | 22.55 | 22.52 | | |
| 1.4 | 3 | 3 | | 22.50 | 22.53 | 22.55 | | |
| 1.4 | 6 | 0 | | 21.40 | 21.38 | 21.45 | | |
| 1.4 | 1 | 0 | 256-QAM | 19.64 | 19.55 | 19.64 | 12.09 | 0.0162 |
| 1.4 | 1 | 3 | | 19.28 | 19.37 | 19.38 | | |
| 1.4 | 1 | 5 | | 19.20 | 19.24 | 19.15 | | |
| 1.4 | 3 | 0 | | 19.26 | 19.18 | 19.24 | | |
| 1.4 | 3 | 1 | | 19.18 | 19.26 | 19.24 | | |
| 1.4 | 3 | 3 | | 19.14 | 19.11 | 19.20 | | |
| 1.4 | 6 | 0 | | 19.12 | 19.12 | 19.21 | | |
| Limit | Power < 100W | | | Result | | | Pass | |



| LTE Band 26(Part90S) Straddle Maximum Average Power [dBm] (GT - LC = -5.4 dB) | | | | | | | | |
|---|----------------|-----------|---------|--------|--------|---------|-----------|---------|
| BW [MHz] | RB Size | RB Offset | Mod | Lowest | Middle | Highest | ERP (dBm) | ERP (W) |
| 15 | 1 | 0 | QPSK | - | 24.48 | - | 16.93 | 0.0493 |
| 15 | 1 | 37 | | - | 24.26 | - | | |
| 15 | 1 | 74 | | - | 24.46 | - | | |
| 15 | 36 | 0 | | - | 23.37 | - | | |
| 15 | 36 | 20 | | - | 23.36 | - | | |
| 15 | 36 | 39 | | - | 23.45 | - | | |
| 15 | 75 | 0 | | - | 23.50 | - | | |
| 15 | 1 | 0 | 16-QAM | - | 23.86 | - | 16.33 | 0.0430 |
| 15 | 1 | 37 | | - | 23.65 | - | | |
| 15 | 1 | 74 | | - | 23.88 | - | | |
| 15 | 36 | 0 | | - | 22.56 | - | | |
| 15 | 36 | 20 | | - | 22.34 | - | | |
| 15 | 36 | 39 | | - | 22.50 | - | | |
| 15 | 75 | 0 | | - | 22.36 | - | | |
| 15 | 1 | 0 | 64-QAM | - | 22.71 | - | 15.16 | 0.0328 |
| 15 | 1 | 37 | | - | 22.55 | - | | |
| 15 | 1 | 74 | | - | 22.50 | - | | |
| 15 | 36 | 0 | | - | 21.59 | - | | |
| 15 | 36 | 20 | | - | 21.46 | - | | |
| 15 | 36 | 39 | | - | 21.45 | - | | |
| 15 | 75 | 0 | | - | 21.40 | - | | |
| 15 | 1 | 0 | 256-QAM | - | 19.66 | - | 12.11 | 0.0163 |
| 15 | 1 | 37 | | - | 19.41 | - | | |
| 15 | 1 | 74 | | - | 19.46 | - | | |
| 15 | 36 | 0 | | - | 19.39 | - | | |
| 15 | 36 | 20 | | - | 19.37 | - | | |
| 15 | 36 | 39 | | - | 19.29 | - | | |
| 15 | 75 | 0 | | - | 19.23 | - | | |
| Limit | Reporting only | | | Result | | | N/A | |



| LTE Band 26 Straddle Maximum Average Power [dBm] (GT - LC = -5.4 dB) | | | | | | | | |
|--|----------------|-----------|---------|--------|--------|---------|-----------|---------|
| BW [MHz] | RB Size | RB Offset | Mod | Lowest | Middle | Highest | ERP (dBm) | ERP (W) |
| 10 | 1 | 0 | QPSK | - | 24.40 | - | 16.87 | 0.0486 |
| 10 | 1 | 25 | | - | 24.17 | - | | |
| 10 | 1 | 49 | | - | 24.42 | - | | |
| 10 | 25 | 0 | | - | 23.39 | - | | |
| 10 | 25 | 12 | | - | 23.25 | - | | |
| 10 | 25 | 25 | | - | 23.27 | - | | |
| 10 | 50 | 0 | | - | 23.20 | - | | |
| 10 | 1 | 0 | 16-QAM | - | 23.60 | - | 16.32 | 0.0429 |
| 10 | 1 | 25 | | - | 23.76 | - | | |
| 10 | 1 | 49 | | - | 23.87 | - | | |
| 10 | 25 | 0 | | - | 22.30 | - | | |
| 10 | 25 | 12 | | - | 22.37 | - | | |
| 10 | 25 | 25 | | - | 22.36 | - | | |
| 10 | 50 | 0 | | - | 22.32 | - | | |
| 10 | 1 | 0 | 64-QAM | - | 22.63 | - | 15.08 | 0.0322 |
| 10 | 1 | 25 | | - | 22.44 | - | | |
| 10 | 1 | 49 | | - | 22.38 | - | | |
| 10 | 25 | 0 | | - | 21.25 | - | | |
| 10 | 25 | 12 | | - | 21.28 | - | | |
| 10 | 25 | 25 | | - | 21.52 | - | | |
| 10 | 50 | 0 | | - | 21.27 | - | | |
| 10 | 1 | 0 | 256-QAM | - | 19.70 | - | 12.15 | 0.0164 |
| 10 | 1 | 25 | | - | 19.22 | - | | |
| 10 | 1 | 49 | | - | 19.41 | - | | |
| 10 | 25 | 0 | | - | 19.24 | - | | |
| 10 | 25 | 12 | | - | 19.27 | - | | |
| 10 | 25 | 25 | | - | 19.36 | - | | |
| 10 | 50 | 0 | | - | 19.19 | - | | |
| Limit | Reporting only | | | Result | | | N/A | |



| LTE Band 26(Part90S) Straddle Maximum Average Power [dBm] (GT - LC = -5.4 dB) | | | | | | | | |
|---|----------------|-----------|---------|--------|--------|---------|-----------|---------|
| BW [MHz] | RB Size | RB Offset | Mod | Lowest | Middle | Highest | ERP (dBm) | ERP (W) |
| 5 | 1 | 0 | QPSK | - | 24.38 | - | 16.83 | 0.0482 |
| 5 | 1 | 12 | | - | 24.32 | - | | |
| 5 | 1 | 24 | | - | 24.20 | - | | |
| 5 | 12 | 0 | | - | 23.26 | - | | |
| 5 | 12 | 7 | | - | 23.38 | - | | |
| 5 | 12 | 13 | | - | 23.35 | - | | |
| 5 | 25 | 0 | | - | 23.35 | - | | |
| 5 | 1 | 0 | 16-QAM | - | 23.62 | - | 16.21 | 0.0418 |
| 5 | 1 | 12 | | - | 23.76 | - | | |
| 5 | 1 | 24 | | - | 23.74 | - | | |
| 5 | 12 | 0 | | - | 22.44 | - | | |
| 5 | 12 | 7 | | - | 22.27 | - | | |
| 5 | 12 | 13 | | - | 22.41 | - | | |
| 5 | 25 | 0 | | - | 22.21 | - | | |
| 5 | 1 | 0 | 64-QAM | - | 22.54 | - | 15.08 | 0.0322 |
| 5 | 1 | 12 | | - | 22.63 | - | | |
| 5 | 1 | 24 | | - | 22.58 | - | | |
| 5 | 12 | 0 | | - | 21.39 | - | | |
| 5 | 12 | 7 | | - | 21.50 | - | | |
| 5 | 12 | 13 | | - | 21.47 | - | | |
| 5 | 25 | 0 | | - | 21.44 | - | | |
| 5 | 1 | 0 | 256-QAM | - | 19.65 | - | 12.10 | 0.0162 |
| 5 | 1 | 12 | | - | 19.14 | - | | |
| 5 | 1 | 24 | | - | 19.31 | - | | |
| 5 | 12 | 0 | | - | 19.30 | - | | |
| 5 | 12 | 7 | | - | 19.09 | - | | |
| 5 | 12 | 13 | | - | 19.34 | - | | |
| 5 | 25 | 0 | | - | 19.19 | - | | |
| Limit | Reporting only | | | Result | | | N/A | |



| LTE Band 26(Part90S) Straddle Maximum Average Power [dBm] (GT - LC = -5.4 dB) | | | | | | | | |
|---|----------------|-----------|---------|--------|--------|---------|-----------|---------|
| BW [MHz] | RB Size | RB Offset | Mod | Lowest | Middle | Highest | ERP (dBm) | ERP (W) |
| 3 | 1 | 0 | QPSK | - | 24.36 | - | 16.84 | 0.0483 |
| 3 | 1 | 8 | | - | 24.23 | - | | |
| 3 | 1 | 14 | | - | 24.39 | - | | |
| 3 | 8 | 0 | | - | 23.31 | - | | |
| 3 | 8 | 4 | | - | 23.42 | - | | |
| 3 | 8 | 7 | | - | 23.31 | - | | |
| 3 | 15 | 0 | | - | 23.18 | - | | |
| 3 | 1 | 0 | 16-QAM | - | 23.69 | - | 16.22 | 0.0419 |
| 3 | 1 | 8 | | - | 23.61 | - | | |
| 3 | 1 | 14 | | - | 23.77 | - | | |
| 3 | 8 | 0 | | - | 22.32 | - | | |
| 3 | 8 | 4 | | - | 22.30 | - | | |
| 3 | 8 | 7 | | - | 22.19 | - | | |
| 3 | 15 | 0 | | - | 22.29 | - | | |
| 3 | 1 | 0 | 64-QAM | - | 22.61 | - | 15.06 | 0.0321 |
| 3 | 1 | 8 | | - | 22.54 | - | | |
| 3 | 1 | 14 | | - | 22.41 | - | | |
| 3 | 8 | 0 | | - | 21.51 | - | | |
| 3 | 8 | 4 | | - | 21.21 | - | | |
| 3 | 8 | 7 | | - | 21.41 | - | | |
| 3 | 15 | 0 | | - | 21.32 | - | | |
| 3 | 1 | 0 | 256-QAM | - | 19.73 | - | 12.18 | 0.0165 |
| 3 | 1 | 8 | | - | 19.16 | - | | |
| 3 | 1 | 14 | | - | 19.21 | - | | |
| 3 | 8 | 0 | | - | 19.35 | - | | |
| 3 | 8 | 4 | | - | 19.22 | - | | |
| 3 | 8 | 7 | | - | 19.03 | - | | |
| 3 | 15 | 0 | | - | 19.03 | - | | |
| Limit | Reporting only | | | Result | | | N/A | |



| LTE Band 26(Part90S) Straddle Maximum Average Power [dBm] (GT - LC = -5.4 dB) | | | | | | | | |
|---|----------------|-----------|---------|--------|--------|---------|-----------|---------|
| BW [MHz] | RB Size | RB Offset | Mod | Lowest | Middle | Highest | ERP (dBm) | ERP (W) |
| 1.4 | 1 | 0 | QPSK | - | 24.26 | - | 16.84 | 0.0483 |
| 1.4 | 1 | 3 | | - | 24.20 | - | | |
| 1.4 | 1 | 5 | | - | 24.39 | - | | |
| 1.4 | 3 | 0 | | - | 24.33 | - | | |
| 1.4 | 3 | 1 | | - | 24.26 | - | | |
| 1.4 | 3 | 3 | | - | 24.26 | - | | |
| 1.4 | 6 | 0 | | - | 23.27 | - | | |
| 1.4 | 1 | 0 | 16-QAM | - | 23.21 | - | 16.25 | 0.0422 |
| 1.4 | 1 | 3 | | - | 23.32 | - | | |
| 1.4 | 1 | 5 | | - | 23.39 | - | | |
| 1.4 | 3 | 0 | | - | 23.80 | - | | |
| 1.4 | 3 | 1 | | - | 23.68 | - | | |
| 1.4 | 3 | 3 | | - | 23.74 | - | | |
| 1.4 | 6 | 0 | | - | 22.32 | - | | |
| 1.4 | 1 | 0 | 64-QAM | - | 22.47 | - | 15.15 | 0.0327 |
| 1.4 | 1 | 3 | | - | 22.17 | - | | |
| 1.4 | 1 | 5 | | - | 22.14 | - | | |
| 1.4 | 3 | 0 | | - | 22.70 | - | | |
| 1.4 | 3 | 1 | | - | 22.43 | - | | |
| 1.4 | 3 | 3 | | - | 22.50 | - | | |
| 1.4 | 6 | 0 | | - | 21.31 | - | | |
| 1.4 | 1 | 0 | 256-QAM | - | 19.68 | - | 12.13 | 0.0163 |
| 1.4 | 1 | 3 | | - | 19.18 | - | | |
| 1.4 | 1 | 5 | | - | 19.22 | - | | |
| 1.4 | 3 | 0 | | - | 19.22 | - | | |
| 1.4 | 3 | 1 | | - | 19.13 | - | | |
| 1.4 | 3 | 3 | | - | 19.23 | - | | |
| 1.4 | 6 | 0 | | - | 19.20 | - | | |
| Limit | Reporting only | | | Result | | | N/A | |



| LTE Band 5B_CA Maximum Average Power [dBm] (GT - LC = -5.4 dB) | | | | | | | | | | |
|--|----------|-----------|---------|-----------|---------|--------|--------|---------|-----------|---------|
| BW [MHz] | PCC | | SCC | | Mod | Lowest | Middle | Highest | ERP (dBm) | ERP (W) |
| | RB Size | RB Offset | RB Size | RB Offset | | | | | | |
| 10+10 | 50 | 0 | 50 | 0 | QPSK | 20.76 | 20.77 | 21.05 | 15.01 | 0.0317 |
| 10+10 | 1 | 0 | 1 | 49 | | 15.33 | 15.38 | 15.32 | | |
| 10+10 | 1 | 49 | 1 | 0 | | 22.46 | 22.41 | 22.56 | | |
| 10+10 | 50 | 0 | 50 | 0 | 16-QAM | 19.76 | 19.78 | 20.02 | 14.40 | 0.0275 |
| 10+10 | 1 | 0 | 1 | 49 | | 15.80 | 15.74 | 15.68 | | |
| 10+10 | 1 | 49 | 1 | 0 | | 21.95 | 21.90 | 21.84 | | |
| 10+10 | 50 | 0 | 50 | 0 | 64-QAM | 19.72 | 19.79 | 20.00 | 12.45 | 0.0176 |
| 10+10 | 1 | 0 | 1 | 49 | | 15.76 | 15.77 | 15.85 | | |
| 10+10 | 1 | 49 | 1 | 0 | | 19.86 | 19.98 | 19.98 | | |
| 10+10 | 50 | 0 | 50 | 0 | 256-QAM | 17.69 | 17.64 | 17.69 | 10.18 | 0.0104 |
| 10+10 | 1 | 0 | 1 | 49 | | 15.66 | 15.65 | 15.74 | | |
| 10+10 | 1 | 49 | 1 | 0 | | 17.73 | 17.71 | 17.72 | | |
| 10+5 | 50 | 0 | 25 | 0 | QPSK | 20.74 | 20.80 | 20.87 | 15.00 | 0.0316 |
| 10+5 | 1 | 0 | 1 | 24 | | 13.82 | 13.56 | 13.72 | | |
| 10+5 | 1 | 49 | 1 | 0 | | 22.35 | 22.53 | 22.55 | | |
| 10+5 | 50 | 0 | 25 | 0 | 16-QAM | 19.78 | 19.82 | 19.87 | 14.42 | 0.0277 |
| 10+5 | 1 | 0 | 1 | 24 | | 14.15 | 14.09 | 14.29 | | |
| 10+5 | 1 | 49 | 1 | 0 | | 21.79 | 21.86 | 21.97 | | |
| 10+5 | 50 | 0 | 25 | 0 | 64-QAM | 19.73 | 19.81 | 19.92 | 12.37 | 0.0173 |
| 10+5 | 1 | 0 | 1 | 24 | | 14.26 | 14.08 | 13.86 | | |
| 10+5 | 1 | 49 | 1 | 0 | | 19.77 | 19.80 | 19.86 | | |
| 10+5 | 50 | 0 | 25 | 0 | 256-QAM | 17.69 | 17.59 | 17.68 | 10.26 | 0.0106 |
| 10+5 | 1 | 0 | 1 | 24 | | 13.77 | 13.97 | 13.92 | | |
| 10+5 | 1 | 49 | 1 | 0 | | 17.72 | 17.81 | 17.59 | | |
| 5+10 | 25 | 0 | 50 | 0 | QPSK | 20.75 | 20.72 | 20.79 | 14.96 | 0.0313 |
| 5+10 | 1 | 0 | 1 | 49 | | 13.62 | 13.52 | 13.44 | | |
| 5+10 | 1 | 24 | 1 | 0 | | 22.50 | 22.44 | 22.51 | | |
| 5+10 | 25 | 0 | 50 | 0 | 16-QAM | 19.74 | 19.73 | 19.77 | 14.32 | 0.0270 |
| 5+10 | 1 | 0 | 1 | 49 | | 13.94 | 13.95 | 13.99 | | |
| 5+10 | 1 | 24 | 1 | 0 | | 21.73 | 21.87 | 21.75 | | |
| 5+10 | 25 | 0 | 50 | 0 | 64-QAM | 19.73 | 19.75 | 19.78 | 12.43 | 0.0175 |
| 5+10 | 1 | 0 | 1 | 49 | | 13.98 | 13.99 | 13.94 | | |
| 5+10 | 1 | 24 | 1 | 0 | | 19.68 | 19.98 | 19.83 | | |
| 5+10 | 25 | 0 | 50 | 0 | 256-QAM | 17.79 | 17.66 | 17.69 | 10.24 | 0.0106 |
| 5+10 | 1 | 0 | 1 | 49 | | 13.79 | 13.83 | 13.92 | | |
| 5+10 | 1 | 24 | 1 | 0 | | 17.63 | 17.77 | 17.74 | | |
| Limit | ERP < 7W | | | | | Result | | | Pass | |



| LTE Band 5B_CA Maximum Average Power [dBm] (GT - LC = -5.4 dB) | | | | | | | | | | |
|--|----------|-----------|---------|-----------|---------|--------|--------|---------|-----------|---------|
| BW [MHz] | PCC | | SCC | | Mod | Lowest | Middle | Highest | ERP (dBm) | ERP (W) |
| | RB Size | RB Offset | RB Size | RB Offset | | | | | | |
| 5+3 | 25 | 0 | 15 | 0 | QPSK | 22.79 | 22.79 | 23.21 | 15.66 | 0.0368 |
| 5+3 | 1 | 0 | 1 | 14 | | 14.24 | 13.87 | 14.75 | | |
| 5+3 | 1 | 24 | 1 | 0 | | 22.57 | 22.57 | 23.01 | | |
| 5+3 | 25 | 0 | 15 | 0 | 16-QAM | 22.80 | 22.77 | 23.24 | 15.69 | 0.0371 |
| 5+3 | 1 | 0 | 1 | 14 | | 14.72 | 14.36 | 15.12 | | |
| 5+3 | 1 | 24 | 1 | 0 | | 22.90 | 22.98 | 23.16 | | |
| 5+3 | 25 | 0 | 15 | 0 | 64-QAM | 22.77 | 22.81 | 23.22 | 15.67 | 0.0369 |
| 5+3 | 1 | 0 | 1 | 14 | | 14.82 | 14.52 | 15.00 | | |
| 5+3 | 1 | 24 | 1 | 0 | | 22.75 | 22.80 | 23.16 | | |
| 5+3 | 25 | 0 | 15 | 0 | 256-QAM | 22.79 | 22.57 | 23.12 | 15.57 | 0.0361 |
| 5+3 | 1 | 0 | 1 | 14 | | 14.77 | 14.24 | 15.00 | | |
| 5+3 | 1 | 24 | 1 | 0 | | 22.78 | 22.66 | 22.91 | | |
| 3+5 | 15 | 0 | 25 | 0 | QPSK | 22.66 | 22.77 | 23.22 | 15.67 | 0.0369 |
| 3+5 | 1 | 0 | 1 | 24 | | 14.35 | 14.13 | 16.76 | | |
| 3+5 | 1 | 14 | 1 | 0 | | 22.34 | 22.53 | 22.90 | | |
| 3+5 | 15 | 0 | 25 | 0 | 16-QAM | 22.67 | 22.84 | 23.25 | 15.70 | 0.0372 |
| 3+5 | 1 | 0 | 1 | 24 | | 15.43 | 14.43 | 15.09 | | |
| 3+5 | 1 | 14 | 1 | 0 | | 22.84 | 22.96 | 23.09 | | |
| 3+5 | 15 | 0 | 25 | 0 | 64-QAM | 22.66 | 22.81 | 23.20 | 15.65 | 0.0367 |
| 3+5 | 1 | 0 | 1 | 24 | | 14.67 | 14.42 | 15.55 | | |
| 3+5 | 1 | 14 | 1 | 0 | | 22.63 | 22.82 | 23.15 | | |
| 3+5 | 15 | 0 | 25 | 0 | 256-QAM | 22.76 | 22.69 | 23.17 | 15.62 | 0.0365 |
| 3+5 | 1 | 0 | 1 | 24 | | 14.57 | 14.44 | 15.04 | | |
| 3+5 | 1 | 14 | 1 | 0 | | 22.68 | 22.64 | 19.93 | | |
| Limit | ERP < 7W | | | | Result | | | Pass | | |



| LTE Band 66B_CA Maximum Average Power [dBm] (GT - LC = -1.78 dB) | | | | | | | | | | |
|--|-----------|-----------|---------|-----------|---------|--------|--------|---------|------------|----------|
| BW [MHz] | PCC | | SCC | | Mod | Lowest | Middle | Highest | EIRP (dBm) | EIRP (W) |
| | RB Size | RB Offset | RB Size | RB Offset | | | | | | |
| 10+10 | 50 | 0 | 50 | 0 | QPSK | 20.69 | 20.43 | 20.39 | 21.02 | 0.1265 |
| 10+10 | 1 | 0 | 1 | 49 | | 15.07 | 14.89 | 14.93 | | |
| 10+10 | 1 | 49 | 1 | 0 | | 22.80 | 22.34 | 22.30 | | |
| 10+10 | 50 | 0 | 50 | 0 | 16-QAM | 19.76 | 19.46 | 19.35 | 20.34 | 0.1081 |
| 10+10 | 1 | 0 | 1 | 49 | | 15.53 | 15.30 | 15.25 | | |
| 10+10 | 1 | 49 | 1 | 0 | | 22.12 | 21.60 | 21.59 | | |
| 10+10 | 50 | 0 | 50 | 0 | 64-QAM | 19.80 | 19.45 | 19.32 | 18.30 | 0.0676 |
| 10+10 | 1 | 0 | 1 | 49 | | 15.53 | 15.33 | 15.33 | | |
| 10+10 | 1 | 49 | 1 | 0 | | 20.08 | 19.63 | 19.71 | | |
| 10+10 | 50 | 0 | 50 | 0 | 256-QAM | 17.73 | 17.45 | 17.39 | 16.23 | 0.0420 |
| 10+10 | 1 | 0 | 1 | 49 | | 15.37 | 15.25 | 15.41 | | |
| 10+10 | 1 | 49 | 1 | 0 | | 18.01 | 17.71 | 17.67 | | |
| 15+5 | 75 | 0 | 25 | 0 | QPSK | 20.72 | 21.32 | 20.45 | 21.40 | 0.1380 |
| 15+5 | 1 | 0 | 1 | 24 | | 15.04 | 15.88 | 15.02 | | |
| 15+5 | 1 | 74 | 1 | 0 | | 22.60 | 23.18 | 22.20 | | |
| 15+5 | 75 | 0 | 25 | 0 | 16-QAM | 19.69 | 20.30 | 19.36 | 20.69 | 0.1172 |
| 15+5 | 1 | 0 | 1 | 24 | | 15.45 | 16.33 | 15.39 | | |
| 15+5 | 1 | 74 | 1 | 0 | | 21.89 | 22.47 | 21.56 | | |
| 15+5 | 75 | 0 | 25 | 0 | 64-QAM | 19.67 | 20.31 | 19.36 | 18.67 | 0.0736 |
| 15+5 | 1 | 0 | 1 | 24 | | 15.43 | 16.35 | 15.35 | | |
| 15+5 | 1 | 74 | 1 | 0 | | 20.14 | 20.45 | 19.65 | | |
| 15+5 | 75 | 0 | 25 | 0 | 256-QAM | 17.79 | 18.41 | 17.52 | 16.85 | 0.0484 |
| 15+5 | 1 | 0 | 1 | 24 | | 15.45 | 16.23 | 15.33 | | |
| 15+5 | 1 | 74 | 1 | 0 | | 18.02 | 18.63 | 17.66 | | |
| 5+15 | 25 | 0 | 75 | 0 | QPSK | 20.73 | 20.39 | 20.33 | 20.91 | 0.1233 |
| 5+15 | 1 | 0 | 1 | 74 | | 15.10 | 14.84 | 14.87 | | |
| 5+15 | 1 | 24 | 1 | 0 | | 22.69 | 22.40 | 22.37 | | |
| 5+15 | 25 | 0 | 75 | 0 | 16-QAM | 19.75 | 19.45 | 19.29 | 20.25 | 0.1059 |
| 5+15 | 1 | 0 | 1 | 74 | | 15.45 | 15.42 | 15.07 | | |
| 5+15 | 1 | 24 | 1 | 0 | | 22.03 | 21.69 | 21.60 | | |
| 5+15 | 25 | 0 | 75 | 0 | 64-QAM | 19.71 | 19.35 | 19.33 | 18.28 | 0.0673 |
| 5+15 | 1 | 0 | 1 | 74 | | 15.32 | 15.11 | 15.19 | | |
| 5+15 | 1 | 24 | 1 | 0 | | 20.06 | 19.64 | 19.53 | | |
| 5+15 | 25 | 0 | 75 | 0 | 256-QAM | 17.77 | 17.43 | 17.37 | 16.22 | 0.0419 |
| 5+15 | 1 | 0 | 1 | 74 | | 15.42 | 15.09 | 15.22 | | |
| 5+15 | 1 | 24 | 1 | 0 | | 18.00 | 17.77 | 17.69 | | |
| Limit | EIRP < 1W | | | | | Result | | | Pass | |



| LTE Band 66B_CA Maximum Average Power [dBm] (GT - LC = -1.78 dB) | | | | | | | | | | |
|--|-----------|-----------|---------|-----------|---------|--------|--------|---------|------------|----------|
| BW [MHz] | PCC | | SCC | | Mod | Lowest | Middle | Highest | EIRP (dBm) | EIRP (W) |
| | RB Size | RB Offset | RB Size | RB Offset | | | | | | |
| 10+5 | 50 | 0 | 25 | 0 | QPSK | 20.79 | 21.37 | 20.40 | 21.34 | 0.1361 |
| 10+5 | 1 | 0 | 1 | 24 | | 13.19 | 14.01 | 13.38 | | |
| 10+5 | 1 | 49 | 1 | 0 | | 22.58 | 23.12 | 22.25 | | |
| 10+5 | 50 | 0 | 25 | 0 | 16-QAM | 19.69 | 20.36 | 19.42 | 20.70 | 0.1175 |
| 10+5 | 1 | 0 | 1 | 24 | | 13.62 | 14.47 | 13.65 | | |
| 10+5 | 1 | 49 | 1 | 0 | | 21.81 | 22.48 | 21.62 | | |
| 10+5 | 50 | 0 | 25 | 0 | 64-QAM | 19.73 | 20.36 | 19.46 | 18.78 | 0.0755 |
| 10+5 | 1 | 0 | 1 | 24 | | 13.42 | 14.44 | 13.67 | | |
| 10+5 | 1 | 49 | 1 | 0 | | 20.07 | 20.56 | 19.70 | | |
| 10+5 | 50 | 0 | 25 | 0 | 256-QAM | 17.71 | 18.37 | 17.43 | 16.88 | 0.0488 |
| 10+5 | 1 | 0 | 1 | 24 | | 13.53 | 14.45 | 13.64 | | |
| 10+5 | 1 | 49 | 1 | 0 | | 17.96 | 18.66 | 17.65 | | |
| 5+10 | 25 | 0 | 50 | 0 | QPSK | 20.81 | 20.51 | 20.40 | 20.90 | 0.1230 |
| 5+10 | 1 | 0 | 1 | 49 | | 13.24 | 13.10 | 13.22 | | |
| 5+10 | 1 | 24 | 1 | 0 | | 22.68 | 22.44 | 22.36 | | |
| 5+10 | 25 | 0 | 50 | 0 | 16-QAM | 19.80 | 19.53 | 19.40 | 20.26 | 0.1062 |
| 5+10 | 1 | 0 | 1 | 49 | | 13.60 | 13.64 | 13.60 | | |
| 5+10 | 1 | 24 | 1 | 0 | | 22.04 | 21.64 | 21.69 | | |
| 5+10 | 25 | 0 | 50 | 0 | 64-QAM | 19.80 | 19.54 | 19.40 | 18.20 | 0.0661 |
| 5+10 | 1 | 0 | 1 | 49 | | 13.65 | 13.48 | 13.56 | | |
| 5+10 | 1 | 24 | 1 | 0 | | 19.98 | 19.67 | 19.67 | | |
| 5+10 | 25 | 0 | 50 | 0 | 256-QAM | 17.74 | 17.58 | 17.46 | 16.09 | 0.0406 |
| 5+10 | 1 | 0 | 1 | 49 | | 13.37 | 13.46 | 13.59 | | |
| 5+10 | 1 | 24 | 1 | 0 | | 17.87 | 17.69 | 17.68 | | |
| 5+5 | 25 | 0 | 25 | 0 | QPSK | 20.83 | 21.40 | 20.52 | 21.62 | 0.1452 |
| 5+5 | 1 | 0 | 1 | 24 | | 13.77 | 14.61 | 13.62 | | |
| 5+5 | 1 | 24 | 1 | 0 | | 22.83 | 23.40 | 22.31 | | |
| 5+5 | 25 | 0 | 25 | 0 | 16-QAM | 19.91 | 20.41 | 19.53 | 20.95 | 0.1245 |
| 5+5 | 1 | 0 | 1 | 24 | | 14.12 | 14.97 | 13.95 | | |
| 5+5 | 1 | 24 | 1 | 0 | | 22.16 | 22.73 | 21.76 | | |
| 5+5 | 25 | 0 | 25 | 0 | 64-QAM | 19.84 | 20.37 | 19.48 | 19.02 | 0.0798 |
| 5+5 | 1 | 0 | 1 | 24 | | 14.14 | 14.92 | 13.89 | | |
| 5+5 | 1 | 24 | 1 | 0 | | 20.11 | 20.80 | 19.70 | | |
| 5+5 | 25 | 0 | 25 | 0 | 256-QAM | 17.72 | 18.37 | 17.43 | 16.94 | 0.0494 |
| 5+5 | 1 | 0 | 1 | 24 | | 14.05 | 14.95 | 13.97 | | |
| 5+5 | 1 | 24 | 1 | 0 | | 17.99 | 18.72 | 17.81 | | |
| Limit | EIRP < 1W | | | | | Result | | | Pass | |



| LTE Band 66C_CA Maximum Average Power [dBm] (GT - LC = -1.78 dB) | | | | | | | | | | |
|--|-----------|-----------|---------|-----------|---------|--------|--------|---------|------------|----------|
| BW [MHz] | PCC | | SCC | | Mod | Lowest | Middle | Highest | EIRP (dBm) | EIRP (W) |
| | RB Size | RB Offset | RB Size | RB Offset | | | | | | |
| 20+20 | 100 | 0 | 100 | 0 | QPSK | 20.72 | 20.57 | 20.57 | 20.98 | 0.1253 |
| 20+20 | 1 | 0 | 1 | 99 | | 15.05 | 14.98 | 15.06 | | |
| 20+20 | 1 | 99 | 1 | 0 | | 22.76 | 22.50 | 22.50 | | |
| 20+20 | 100 | 0 | 100 | 0 | 16-QAM | 19.72 | 19.59 | 19.56 | 20.39 | 0.1094 |
| 20+20 | 1 | 0 | 1 | 99 | | 15.47 | 15.43 | 15.46 | | |
| 20+20 | 1 | 99 | 1 | 0 | | 22.17 | 21.88 | 21.86 | | |
| 20+20 | 100 | 0 | 100 | 0 | 64-QAM | 19.72 | 19.60 | 19.57 | 18.28 | 0.0673 |
| 20+20 | 1 | 0 | 1 | 99 | | 15.43 | 15.34 | 15.42 | | |
| 20+20 | 1 | 99 | 1 | 0 | | 20.06 | 19.87 | 19.88 | | |
| 20+20 | 100 | 0 | 100 | 0 | 256-QAM | 17.72 | 17.79 | 17.57 | 16.31 | 0.0428 |
| 20+20 | 1 | 0 | 1 | 99 | | 15.37 | 15.35 | 15.32 | | |
| 20+20 | 1 | 99 | 1 | 0 | | 18.09 | 17.79 | 18.01 | | |
| 20+15 | 100 | 0 | 75 | 0 | QPSK | 20.64 | 20.46 | 20.83 | 20.94 | 0.1242 |
| 20+15 | 1 | 0 | 1 | 74 | | 15.04 | 14.87 | 15.24 | | |
| 20+15 | 1 | 74 | 1 | 0 | | 22.72 | 22.38 | 22.70 | | |
| 20+15 | 100 | 0 | 75 | 0 | 16-QAM | 19.66 | 19.47 | 19.80 | 20.35 | 0.1084 |
| 20+15 | 1 | 0 | 1 | 74 | | 15.47 | 15.40 | 15.50 | | |
| 20+15 | 1 | 74 | 1 | 0 | | 22.13 | 21.65 | 22.10 | | |
| 20+15 | 100 | 0 | 75 | 0 | 64-QAM | 19.70 | 19.67 | 19.83 | 18.28 | 0.0673 |
| 20+15 | 1 | 0 | 1 | 74 | | 15.40 | 15.19 | 15.58 | | |
| 20+15 | 1 | 74 | 1 | 0 | | 20.05 | 19.58 | 20.06 | | |
| 20+15 | 100 | 0 | 75 | 0 | 256-QAM | 17.68 | 17.40 | 17.75 | 16.52 | 0.0449 |
| 20+15 | 1 | 0 | 1 | 74 | | 15.24 | 15.14 | 15.58 | | |
| 20+15 | 1 | 74 | 1 | 0 | | 17.99 | 17.72 | 18.30 | | |
| 15+20 | 75 | 0 | 100 | 0 | QPSK | 20.74 | 20.48 | 21.30 | 21.49 | 0.1409 |
| 15+20 | 1 | 0 | 1 | 99 | | 14.94 | 14.82 | 15.60 | | |
| 15+20 | 1 | 74 | 1 | 0 | | 22.76 | 22.47 | 23.27 | | |
| 15+20 | 75 | 0 | 100 | 0 | 16-QAM | 19.69 | 19.48 | 20.27 | 20.84 | 0.1213 |
| 15+20 | 1 | 0 | 1 | 99 | | 15.22 | 15.36 | 16.00 | | |
| 15+20 | 1 | 74 | 1 | 0 | | 22.26 | 21.82 | 22.62 | | |
| 15+20 | 75 | 0 | 100 | 0 | 64-QAM | 19.69 | 19.47 | 20.31 | 18.93 | 0.0782 |
| 15+20 | 1 | 0 | 1 | 99 | | 15.33 | 15.16 | 16.10 | | |
| 15+20 | 1 | 74 | 1 | 0 | | 20.07 | 19.93 | 20.71 | | |
| 15+20 | 75 | 0 | 100 | 0 | 256-QAM | 17.64 | 17.83 | 18.23 | 16.68 | 0.0466 |
| 15+20 | 1 | 0 | 1 | 99 | | 15.34 | 15.21 | 15.86 | | |
| 15+20 | 1 | 74 | 1 | 0 | | 18.03 | 17.75 | 18.46 | | |
| Limit | EIRP < 1W | | | | | Result | | | Pass | |



| LTE Band 66C_CA Maximum Average Power [dBm] (GT - LC = -1.78 dB) | | | | | | | | | | |
|--|-----------|-----------|---------|-----------|---------|--------|--------|---------|------------|----------|
| BW [MHz] | PCC | | SCC | | Mod | Lowest | Middle | Highest | EIRP (dBm) | EIRP (W) |
| | RB Size | RB Offset | RB Size | RB Offset | | | | | | |
| 20+10 | 100 | 0 | 50 | 0 | QPSK | 20.71 | 20.44 | 20.39 | 20.91 | 0.1233 |
| 20+10 | 1 | 0 | 1 | 49 | | 15.03 | 14.77 | 15.09 | | |
| 20+10 | 1 | 99 | 1 | 0 | | 22.69 | 22.29 | 22.26 | | |
| 20+10 | 100 | 0 | 50 | 0 | 16-QAM | 19.67 | 19.43 | 19.47 | 20.37 | 0.1089 |
| 20+10 | 1 | 0 | 1 | 49 | | 15.27 | 15.31 | 15.35 | | |
| 20+10 | 1 | 99 | 1 | 0 | | 22.15 | 21.70 | 21.63 | | |
| 20+10 | 100 | 0 | 50 | 0 | 64-QAM | 19.66 | 19.42 | 19.37 | 18.27 | 0.0671 |
| 20+10 | 1 | 0 | 1 | 49 | | 15.59 | 15.26 | 15.43 | | |
| 20+10 | 1 | 99 | 1 | 0 | | 20.05 | 19.66 | 19.77 | | |
| 20+10 | 100 | 0 | 50 | 0 | 256-QAM | 17.73 | 19.16 | 17.34 | 17.38 | 0.0547 |
| 20+10 | 1 | 0 | 1 | 49 | | 15.48 | 15.39 | 15.05 | | |
| 20+10 | 1 | 99 | 1 | 0 | | 18.32 | 17.64 | 17.50 | | |
| 10+20 | 50 | 0 | 100 | 0 | QPSK | 20.72 | 20.49 | 20.58 | 20.93 | 0.1239 |
| 10+20 | 1 | 0 | 1 | 99 | | 14.96 | 14.79 | 14.99 | | |
| 10+20 | 1 | 49 | 1 | 0 | | 22.71 | 22.46 | 22.57 | | |
| 10+20 | 50 | 0 | 100 | 0 | 16-QAM | 19.71 | 19.46 | 19.54 | 20.40 | 0.1096 |
| 10+20 | 1 | 0 | 1 | 99 | | 15.41 | 15.16 | 15.21 | | |
| 10+20 | 1 | 49 | 1 | 0 | | 22.18 | 21.92 | 21.96 | | |
| 10+20 | 50 | 0 | 100 | 0 | 64-QAM | 19.70 | 19.49 | 19.60 | 18.35 | 0.0684 |
| 10+20 | 1 | 0 | 1 | 99 | | 15.23 | 14.97 | 15.36 | | |
| 10+20 | 1 | 49 | 1 | 0 | | 20.13 | 19.93 | 19.91 | | |
| 10+20 | 50 | 0 | 100 | 0 | 256-QAM | 17.76 | 17.54 | 17.64 | 16.47 | 0.0444 |
| 10+20 | 1 | 0 | 1 | 99 | | 15.27 | 15.19 | 15.27 | | |
| 10+20 | 1 | 49 | 1 | 0 | | 18.25 | 17.79 | 17.91 | | |
| 20+5 | 100 | 0 | 25 | 0 | QPSK | 20.69 | 21.41 | 20.41 | 21.41 | 0.1384 |
| 20+5 | 1 | 0 | 1 | 24 | | 15.10 | 16.07 | 15.06 | | |
| 20+5 | 1 | 99 | 1 | 0 | | 22.89 | 23.19 | 22.16 | | |
| 20+5 | 100 | 0 | 25 | 0 | 16-QAM | 19.73 | 20.39 | 19.35 | 20.93 | 0.1239 |
| 20+5 | 1 | 0 | 1 | 24 | | 15.53 | 16.43 | 15.63 | | |
| 20+5 | 1 | 99 | 1 | 0 | | 22.07 | 22.71 | 21.47 | | |
| 20+5 | 100 | 0 | 25 | 0 | 64-QAM | 19.70 | 20.45 | 19.42 | 18.87 | 0.0771 |
| 20+5 | 1 | 0 | 1 | 24 | | 15.60 | 16.39 | 15.51 | | |
| 20+5 | 1 | 99 | 1 | 0 | | 19.78 | 20.65 | 19.52 | | |
| 20+5 | 100 | 0 | 25 | 0 | 256-QAM | 17.69 | 18.35 | 17.62 | 16.72 | 0.0470 |
| 20+5 | 1 | 0 | 1 | 24 | | 15.26 | 16.18 | 15.36 | | |
| 20+5 | 1 | 99 | 1 | 0 | | 18.01 | 18.50 | 17.47 | | |
| Limit | EIRP < 1W | | | | | Result | | | Pass | |



| LTE Band 66C_CA Maximum Average Power [dBm] (GT - LC = -1.78 dB) | | | | | | | | | | |
|--|-----------|-----------|---------|-----------|---------|--------|--------|---------|------------|----------|
| BW [MHz] | PCC | | SCC | | Mod | Lowest | Middle | Highest | EIRP (dBm) | EIRP (W) |
| | RB Size | RB Offset | RB Size | RB Offset | | | | | | |
| 5+20 | 25 | 0 | 100 | 0 | QPSK | 20.76 | 20.53 | 20.40 | 21.00 | 0.1259 |
| 5+20 | 1 | 0 | 1 | 99 | | 15.07 | 14.82 | 14.81 | | |
| 5+20 | 1 | 24 | 1 | 0 | | 22.78 | 22.49 | 22.52 | | |
| 5+20 | 25 | 0 | 100 | 0 | 16-QAM | 19.78 | 19.52 | 19.44 | 20.43 | 0.1104 |
| 5+20 | 1 | 0 | 1 | 99 | | 15.62 | 15.21 | 15.21 | | |
| 5+20 | 1 | 24 | 1 | 0 | | 22.21 | 21.74 | 21.81 | | |
| 5+20 | 25 | 0 | 100 | 0 | 64-QAM | 19.76 | 19.51 | 19.41 | 18.22 | 0.0664 |
| 5+20 | 1 | 0 | 1 | 99 | | 15.33 | 15.23 | 15.14 | | |
| 5+20 | 1 | 24 | 1 | 0 | | 20.00 | 19.85 | 19.69 | | |
| 5+20 | 25 | 0 | 100 | 0 | 256-QAM | 17.71 | 17.43 | 17.43 | 16.15 | 0.0412 |
| 5+20 | 1 | 0 | 1 | 99 | | 15.29 | 15.18 | 15.14 | | |
| 5+20 | 1 | 24 | 1 | 0 | | 17.93 | 17.75 | 17.74 | | |
| Limit | EIRP < 1W | | | | | Result | | | Pass | |



| LTE Band 66C_CA Maximum Average Power [dBm] (GT - LC = -1.78 dB) | | | | | | | | | | |
|--|-----------|-----------|---------|-----------|---------|--------|--------|---------|------------|----------|
| BW [MHz] | PCC | | SCC | | Mod | Lowest | Middle | Highest | EIRP (dBm) | EIRP (W) |
| | RB Size | RB Offset | RB Size | RB Offset | | | | | | |
| 15+10 | 75 | 0 | 50 | 0 | QPSK | 20.74 | 20.44 | 20.32 | 21.04 | 0.1271 |
| 15+10 | 1 | 0 | 1 | 49 | | 15.09 | 14.88 | 14.94 | | |
| 15+10 | 1 | 74 | 1 | 0 | | 22.82 | 22.35 | 22.26 | | |
| 15+10 | 75 | 0 | 50 | 0 | 16-QAM | 19.68 | 19.50 | 19.32 | 20.39 | 0.1094 |
| 15+10 | 1 | 0 | 1 | 49 | | 15.62 | 15.52 | 15.42 | | |
| 15+10 | 1 | 74 | 1 | 0 | | 22.17 | 21.75 | 21.67 | | |
| 15+10 | 75 | 0 | 50 | 0 | 64-QAM | 19.78 | 19.40 | 19.37 | 18.49 | 0.0706 |
| 15+10 | 1 | 0 | 1 | 49 | | 15.58 | 15.26 | 15.15 | | |
| 15+10 | 1 | 74 | 1 | 0 | | 20.27 | 19.56 | 19.64 | | |
| 15+10 | 75 | 0 | 50 | 0 | 256-QAM | 17.76 | 17.47 | 17.35 | 16.28 | 0.0425 |
| 15+10 | 1 | 0 | 1 | 49 | | 15.51 | 15.30 | 15.18 | | |
| 15+10 | 1 | 74 | 1 | 0 | | 18.06 | 17.55 | 17.66 | | |
| 10+15 | 50 | 0 | 75 | 0 | QPSK | 20.77 | 20.45 | 20.40 | 20.96 | 0.1247 |
| 10+15 | 1 | 0 | 1 | 74 | | 15.07 | 14.88 | 14.83 | | |
| 10+15 | 1 | 49 | 1 | 0 | | 22.74 | 22.39 | 22.35 | | |
| 10+15 | 50 | 0 | 75 | 0 | 16-QAM | 19.77 | 19.43 | 19.37 | 20.26 | 0.1062 |
| 10+15 | 1 | 0 | 1 | 74 | | 15.47 | 15.25 | 15.32 | | |
| 10+15 | 1 | 49 | 1 | 0 | | 22.04 | 21.76 | 21.69 | | |
| 10+15 | 50 | 0 | 75 | 0 | 64-QAM | 19.71 | 19.45 | 19.37 | 18.30 | 0.0676 |
| 10+15 | 1 | 0 | 1 | 74 | | 15.42 | 15.25 | 15.13 | | |
| 10+15 | 1 | 49 | 1 | 0 | | 20.08 | 19.76 | 19.71 | | |
| 10+15 | 50 | 0 | 75 | 0 | 256-QAM | 17.81 | 17.45 | 17.35 | 17.41 | 0.0551 |
| 10+15 | 1 | 0 | 1 | 74 | | 15.53 | 15.28 | 15.12 | | |
| 10+15 | 1 | 49 | 1 | 0 | | 18.02 | 17.67 | 19.19 | | |
| 15+15 | 75 | 0 | 75 | 0 | QPSK | 20.68 | 20.45 | 20.47 | 20.99 | 0.1256 |
| 15+15 | 1 | 0 | 1 | 74 | | 15.11 | 14.95 | 15.02 | | |
| 15+15 | 1 | 74 | 1 | 0 | | 22.77 | 22.46 | 22.44 | | |
| 15+15 | 75 | 0 | 75 | 0 | 16-QAM | 19.79 | 19.61 | 19.47 | 20.51 | 0.1125 |
| 15+15 | 1 | 0 | 1 | 74 | | 15.58 | 15.26 | 15.49 | | |
| 15+15 | 1 | 74 | 1 | 0 | | 22.29 | 21.86 | 21.83 | | |
| 15+15 | 75 | 0 | 75 | 0 | 64-QAM | 19.82 | 19.56 | 19.42 | 18.35 | 0.0684 |
| 15+15 | 1 | 0 | 1 | 74 | | 15.42 | 15.33 | 15.37 | | |
| 15+15 | 1 | 74 | 1 | 0 | | 20.13 | 19.90 | 19.93 | | |
| 15+15 | 75 | 0 | 75 | 0 | 256-QAM | 17.72 | 17.47 | 17.41 | 16.38 | 0.0435 |
| 15+15 | 1 | 0 | 1 | 74 | | 15.44 | 15.24 | 15.35 | | |
| 15+15 | 1 | 74 | 1 | 0 | | 18.16 | 17.72 | 17.86 | | |
| Limit | EIRP < 1W | | | | | Result | | | Pass | |



| LTE Band 7C_CA Maximum Average Power [dBm] (GT - LC = -0.66 dB) | | | | | | | | | | |
|---|-----------|-----------|---------|-----------|---------|--------|--------|---------|------------|----------|
| BW [MHz] | PCC | | SCC | | Mod | Lowest | Middle | Highest | EIRP (dBm) | EIRP (W) |
| | RB Size | RB Offset | RB Size | RB Offset | | | | | | |
| 20+20 | 100 | 0 | 100 | 0 | QPSK | 20.22 | 20.65 | 20.63 | 21.80 | 0.1514 |
| 20+20 | 1 | 0 | 1 | 99 | | 14.42 | 14.57 | 14.86 | | |
| 20+20 | 1 | 99 | 1 | 0 | | 22.46 | 22.39 | 22.40 | | |
| 20+20 | 100 | 0 | 100 | 0 | 16-QAM | 19.28 | 20.11 | 19.60 | 21.28 | 0.1343 |
| 20+20 | 1 | 0 | 1 | 99 | | 15.16 | 15.18 | 15.61 | | |
| 20+20 | 1 | 99 | 1 | 0 | | 21.85 | 21.94 | 21.86 | | |
| 20+20 | 100 | 0 | 100 | 0 | 64-QAM | 19.38 | 19.57 | 19.61 | 19.16 | 0.0824 |
| 20+20 | 1 | 0 | 1 | 99 | | 15.01 | 15.10 | 15.42 | | |
| 20+20 | 1 | 99 | 1 | 0 | | 19.78 | 19.82 | 19.80 | | |
| 20+20 | 100 | 0 | 100 | 0 | 256-QAM | 17.37 | 17.70 | 17.48 | 17.24 | 0.0530 |
| 20+20 | 1 | 0 | 1 | 99 | | 14.69 | 15.16 | 15.30 | | |
| 20+20 | 1 | 99 | 1 | 0 | | 17.90 | 17.81 | 17.81 | | |
| 20+15 | 100 | 0 | 75 | 0 | QPSK | 20.31 | 20.49 | 20.68 | 22.10 | 0.1622 |
| 20+15 | 1 | 0 | 1 | 74 | | 14.38 | 14.61 | 14.84 | | |
| 20+15 | 1 | 99 | 1 | 0 | | 22.25 | 22.76 | 22.44 | | |
| 20+15 | 100 | 0 | 75 | 0 | 16-QAM | 19.32 | 19.50 | 19.67 | 21.51 | 0.1416 |
| 20+15 | 1 | 0 | 1 | 74 | | 15.29 | 15.33 | 15.37 | | |
| 20+15 | 1 | 99 | 1 | 0 | | 21.97 | 22.17 | 22.13 | | |
| 20+15 | 100 | 0 | 75 | 0 | 64-QAM | 19.29 | 19.82 | 19.61 | 19.32 | 0.0855 |
| 20+15 | 1 | 0 | 1 | 74 | | 15.06 | 15.36 | 15.42 | | |
| 20+15 | 1 | 99 | 1 | 0 | | 19.81 | 19.74 | 19.98 | | |
| 20+15 | 100 | 0 | 75 | 0 | 256-QAM | 17.32 | 17.75 | 17.62 | 17.40 | 0.0550 |
| 20+15 | 1 | 0 | 1 | 74 | | 14.76 | 15.01 | 15.42 | | |
| 20+15 | 1 | 99 | 1 | 0 | | 18.06 | 17.73 | 17.86 | | |
| 15+20 | 75 | 0 | 100 | 0 | QPSK | 20.39 | 20.40 | 20.49 | 23.32 | 0.2148 |
| 15+20 | 1 | 0 | 1 | 99 | | 14.50 | 14.74 | 14.58 | | |
| 15+20 | 1 | 74 | 1 | 0 | | 22.44 | 23.98 | 22.42 | | |
| 15+20 | 75 | 0 | 100 | 0 | 16-QAM | 19.36 | 19.46 | 19.47 | 21.38 | 0.1374 |
| 15+20 | 1 | 0 | 1 | 99 | | 15.14 | 15.12 | 15.24 | | |
| 15+20 | 1 | 74 | 1 | 0 | | 21.95 | 21.70 | 22.04 | | |
| 15+20 | 75 | 0 | 100 | 0 | 64-QAM | 19.36 | 19.45 | 19.50 | 22.21 | 0.1663 |
| 15+20 | 1 | 0 | 1 | 99 | | 14.82 | 15.19 | 22.87 | | |
| 15+20 | 1 | 74 | 1 | 0 | | 19.92 | 19.86 | 19.84 | | |
| 15+20 | 75 | 0 | 100 | 0 | 256-QAM | 17.43 | 17.66 | 17.55 | 17.52 | 0.0565 |
| 15+20 | 1 | 0 | 1 | 99 | | 14.80 | 14.94 | 15.21 | | |
| 15+20 | 1 | 74 | 1 | 0 | | 18.18 | 17.75 | 17.82 | | |
| Limit | EIRP < 2W | | | | | Result | | | Pass | |



| LTE Band 7C_CA Maximum Average Power [dBm] (GT - LC = -0.66 dB) | | | | | | | | | | |
|---|-----------|-----------|---------|-----------|---------|--------|--------|---------|------------|----------|
| BW [MHz] | PCC | | SCC | | Mod | Lowest | Middle | Highest | EIRP (dBm) | EIRP (W) |
| | RB Size | RB Offset | RB Size | RB Offset | | | | | | |
| 20+10 | 100 | 0 | 75 | 0 | QPSK | 20.35 | 20.44 | 20.76 | 22.19 | 0.1656 |
| 20+10 | 1 | 0 | 1 | 74 | | 14.38 | 14.88 | 14.92 | | |
| 20+10 | 1 | 99 | 1 | 0 | | 22.38 | 22.45 | 22.85 | | |
| 20+10 | 100 | 0 | 75 | 0 | 16-QAM | 19.33 | 19.61 | 19.71 | 21.61 | 0.1449 |
| 20+10 | 1 | 0 | 1 | 74 | | 14.98 | 15.60 | 15.73 | | |
| 20+10 | 1 | 99 | 1 | 0 | | 21.89 | 21.91 | 22.27 | | |
| 20+10 | 100 | 0 | 75 | 0 | 64-QAM | 19.34 | 19.50 | 19.73 | 19.48 | 0.0887 |
| 20+10 | 1 | 0 | 1 | 74 | | 14.97 | 15.35 | 15.62 | | |
| 20+10 | 1 | 99 | 1 | 0 | | 19.74 | 19.78 | 20.14 | | |
| 20+10 | 100 | 0 | 75 | 0 | 256-QAM | 19.26 | 17.63 | 17.77 | 18.60 | 0.0724 |
| 20+10 | 1 | 0 | 1 | 74 | | 14.79 | 15.53 | 15.48 | | |
| 20+10 | 1 | 99 | 1 | 0 | | 17.82 | 17.89 | 17.83 | | |
| 10+20 | 75 | 0 | 100 | 0 | QPSK | 20.34 | 20.43 | 20.62 | 21.81 | 0.1517 |
| 10+20 | 1 | 0 | 1 | 99 | | 14.67 | 14.62 | 14.43 | | |
| 10+20 | 1 | 74 | 1 | 0 | | 22.38 | 22.37 | 22.47 | | |
| 10+20 | 75 | 0 | 100 | 0 | 16-QAM | 19.53 | 19.43 | 19.59 | 21.45 | 0.1396 |
| 10+20 | 1 | 0 | 1 | 99 | | 14.68 | 15.28 | 15.34 | | |
| 10+20 | 1 | 74 | 1 | 0 | | 21.76 | 21.97 | 22.11 | | |
| 10+20 | 75 | 0 | 100 | 0 | 64-QAM | 19.38 | 19.45 | 19.57 | 19.24 | 0.0839 |
| 10+20 | 1 | 0 | 1 | 99 | | 14.86 | 15.19 | 15.28 | | |
| 10+20 | 1 | 74 | 1 | 0 | | 19.82 | 19.80 | 19.90 | | |
| 10+20 | 75 | 0 | 100 | 0 | 256-QAM | 17.29 | 17.60 | 17.55 | 17.22 | 0.0527 |
| 10+20 | 1 | 0 | 1 | 99 | | 14.87 | 14.96 | 15.12 | | |
| 10+20 | 1 | 74 | 1 | 0 | | 17.78 | 17.69 | 17.88 | | |
| 15+15 | 75 | 0 | 100 | 0 | QPSK | 20.50 | 23.37 | 20.75 | 23.58 | 0.2280 |
| 15+15 | 1 | 0 | 1 | 99 | | 14.40 | 24.24 | 14.83 | | |
| 15+15 | 1 | 74 | 1 | 0 | | 22.52 | 24.23 | 24.11 | | |
| 15+15 | 75 | 0 | 100 | 0 | 16-QAM | 19.52 | 22.44 | 19.80 | 23.16 | 0.2070 |
| 15+15 | 1 | 0 | 1 | 99 | | 15.07 | 23.81 | 15.20 | | |
| 15+15 | 1 | 74 | 1 | 0 | | 21.96 | 23.82 | 21.87 | | |
| 15+15 | 75 | 0 | 100 | 0 | 64-QAM | 19.57 | 21.41 | 19.76 | 22.12 | 0.1629 |
| 15+15 | 1 | 0 | 1 | 99 | | 15.03 | 22.78 | 15.26 | | |
| 15+15 | 1 | 74 | 1 | 0 | | 19.97 | 22.69 | 19.82 | | |
| 15+15 | 75 | 0 | 100 | 0 | 256-QAM | 17.33 | 17.71 | 17.65 | 17.33 | 0.0541 |
| 15+15 | 1 | 0 | 1 | 99 | | 14.86 | 15.30 | 15.32 | | |
| 15+15 | 1 | 74 | 1 | 0 | | 17.85 | 17.83 | 17.99 | | |
| Limit | EIRP < 2W | | | | | Result | | | Pass | |



| LTE Band 7C_CA Maximum Average Power [dBm] (GT - LC = -0.66 dB) | | | | | | | | | | |
|---|-----------|-----------|---------|-----------|---------|--------|--------|---------|------------|----------|
| BW [MHz] | PCC | | SCC | | Mod | Lowest | Middle | Highest | EIRP (dBm) | EIRP (W) |
| | RB Size | RB Offset | RB Size | RB Offset | | | | | | |
| 15+10 | 75 | 0 | 100 | 0 | QPSK | 20.50 | 20.49 | 20.78 | 21.88 | 0.1542 |
| 15+10 | 1 | 0 | 1 | 99 | | 14.46 | 14.92 | 14.95 | | |
| 15+10 | 1 | 74 | 1 | 0 | | 22.39 | 22.34 | 22.54 | | |
| 15+10 | 75 | 0 | 100 | 0 | 16-QAM | 19.41 | 19.54 | 19.77 | 21.43 | 0.1390 |
| 15+10 | 1 | 0 | 1 | 99 | | 14.96 | 15.33 | 15.29 | | |
| 15+10 | 1 | 74 | 1 | 0 | | 22.09 | 21.86 | 21.85 | | |
| 15+10 | 75 | 0 | 100 | 0 | 64-QAM | 19.45 | 19.55 | 19.74 | 19.26 | 0.0843 |
| 15+10 | 1 | 0 | 1 | 99 | | 14.74 | 15.48 | 15.47 | | |
| 15+10 | 1 | 74 | 1 | 0 | | 19.92 | 19.88 | 19.79 | | |
| 15+10 | 75 | 0 | 100 | 0 | 256-QAM | 17.62 | 17.61 | 17.78 | 17.28 | 0.0535 |
| 15+10 | 1 | 0 | 1 | 99 | | 14.89 | 15.41 | 15.40 | | |
| 15+10 | 1 | 74 | 1 | 0 | | 17.91 | 17.86 | 17.94 | | |
| Limit | EIRP < 2W | | | | | Result | | | Pass | |



| LTE Band 38C_CA Maximum Average Power [dBm] (GT - LC = -1.49 dB) | | | | | | | | | | |
|--|-----------|-----------|---------|-----------|---------|--------|--------|---------|------------|----------|
| BW [MHz] | PCC | | SCC | | Mod | Lowest | Middle | Highest | EIRP (dBm) | EIRP (W) |
| | RB Size | RB Offset | RB Size | RB Offset | | | | | | |
| 20+20 | 100 | 0 | 100 | 0 | QPSK | 19.27 | 19.33 | 19.26 | 17.84 | 0.0608 |
| 20+20 | 1 | 0 | 1 | 99 | | 8.86 | 8.87 | 8.87 | | |
| 20+20 | 1 | 99 | 1 | 0 | | 8.61 | 8.62 | 8.60 | | |
| 20+20 | 100 | 0 | 100 | 0 | 16-QAM | 18.33 | 18.32 | 18.33 | 16.84 | 0.0483 |
| 20+20 | 1 | 0 | 1 | 99 | | 9.43 | 9.65 | 9.55 | | |
| 20+20 | 1 | 99 | 1 | 0 | | 9.32 | 9.40 | 9.31 | | |
| 20+20 | 100 | 0 | 100 | 0 | 64-QAM | 18.28 | 18.32 | 18.30 | 16.83 | 0.0482 |
| 20+20 | 1 | 0 | 1 | 99 | | 8.25 | 8.09 | 9.82 | | |
| 20+20 | 1 | 99 | 1 | 0 | | 7.99 | 7.81 | 8.06 | | |
| 20+20 | 100 | 0 | 100 | 0 | 256-QAM | 17.38 | 17.36 | 17.35 | 15.89 | 0.0388 |
| 20+20 | 1 | 0 | 1 | 99 | | 6.91 | 6.94 | 7.17 | | |
| 20+20 | 1 | 99 | 1 | 0 | | 6.65 | 6.68 | 6.90 | | |
| 15+15 | 75 | 0 | 75 | 0 | QPSK | 19.29 | 19.22 | 19.31 | 17.82 | 0.0605 |
| 15+15 | 1 | 0 | 1 | 74 | | 8.88 | 8.78 | 8.80 | | |
| 15+15 | 1 | 74 | 1 | 0 | | 8.65 | 8.61 | 8.62 | | |
| 15+15 | 75 | 0 | 75 | 0 | 16-QAM | 18.30 | 18.28 | 18.30 | 16.81 | 0.0480 |
| 15+15 | 1 | 0 | 1 | 74 | | 9.48 | 9.44 | 9.33 | | |
| 15+15 | 1 | 74 | 1 | 0 | | 9.33 | 9.27 | 9.19 | | |
| 15+15 | 75 | 0 | 75 | 0 | 64-QAM | 18.24 | 18.28 | 18.35 | 16.86 | 0.0485 |
| 15+15 | 1 | 0 | 1 | 74 | | 8.15 | 8.03 | 8.06 | | |
| 15+15 | 1 | 74 | 1 | 0 | | 7.98 | 7.88 | 7.93 | | |
| 15+15 | 75 | 0 | 75 | 0 | 256-QAM | 17.35 | 17.35 | 17.40 | 15.91 | 0.0390 |
| 15+15 | 1 | 0 | 1 | 74 | | 7.02 | 6.79 | 7.01 | | |
| 15+15 | 1 | 74 | 1 | 0 | | 6.86 | 6.63 | 6.88 | | |
| Limit | EIRP < 2W | | | | Result | | | | Pass | |



| LTE Band 41C_CA Maximum Average Power [dBm] (GT - LC = -0.44 dB) | | | | | | | | | | |
|--|-----------|-----------|---------|-----------|---------|--------|--------|---------|------------|----------|
| BW [MHz] | PCC | | SCC | | Mod | Lowest | Middle | Highest | EIRP (dBm) | EIRP (W) |
| | RB Size | RB Offset | RB Size | RB Offset | | | | | | |
| 20+20 | 100 | 0 | 100 | 0 | QPSK | 19.06 | 19.28 | 19.49 | 19.05 | 0.0804 |
| 20+20 | 1 | 0 | 1 | 99 | | 8.59 | 8.74 | 8.77 | | |
| 20+20 | 1 | 99 | 1 | 0 | | 8.48 | 8.57 | 8.74 | | |
| 20+20 | 100 | 0 | 100 | 0 | 16-QAM | 18.08 | 18.25 | 18.30 | 17.86 | 0.0611 |
| 20+20 | 1 | 0 | 1 | 99 | | 9.04 | 9.30 | 9.43 | | |
| 20+20 | 1 | 99 | 1 | 0 | | 9.07 | 9.14 | 9.43 | | |
| 20+20 | 100 | 0 | 100 | 0 | 64-QAM | 18.06 | 18.25 | 18.32 | 17.88 | 0.0614 |
| 20+20 | 1 | 0 | 1 | 99 | | 7.57 | 8.23 | 8.20 | | |
| 20+20 | 1 | 99 | 1 | 0 | | 7.84 | 8.04 | 8.23 | | |
| 20+20 | 100 | 0 | 100 | 0 | 256-QAM | 17.09 | 17.29 | 17.31 | 16.87 | 0.0486 |
| 20+20 | 1 | 0 | 1 | 99 | | 6.60 | 7.05 | 6.89 | | |
| 20+20 | 1 | 99 | 1 | 0 | | 6.64 | 6.89 | 6.88 | | |
| 20+15 | 100 | 0 | 75 | 0 | QPSK | 19.10 | 19.20 | 19.36 | 18.92 | 0.0780 |
| 20+15 | 1 | 0 | 1 | 74 | | 8.48 | 8.78 | 8.79 | | |
| 20+15 | 1 | 99 | 1 | 0 | | 8.51 | 8.58 | 8.73 | | |
| 20+15 | 100 | 0 | 75 | 0 | 16-QAM | 18.06 | 18.25 | 18.28 | 17.84 | 0.0608 |
| 20+15 | 1 | 0 | 1 | 74 | | 8.96 | 9.58 | 9.61 | | |
| 20+15 | 1 | 99 | 1 | 0 | | 9.17 | 9.37 | 9.52 | | |
| 20+15 | 100 | 0 | 75 | 0 | 64-QAM | 18.10 | 18.26 | 18.33 | 17.89 | 0.0615 |
| 20+15 | 1 | 0 | 1 | 74 | | 7.74 | 8.27 | 8.19 | | |
| 20+15 | 1 | 99 | 1 | 0 | | 7.87 | 7.88 | 8.05 | | |
| 20+15 | 100 | 0 | 75 | 0 | 256-QAM | 17.08 | 17.28 | 17.35 | 16.91 | 0.0491 |
| 20+15 | 1 | 0 | 1 | 74 | | 6.69 | 7.02 | 7.05 | | |
| 20+15 | 1 | 99 | 1 | 0 | | 6.47 | 6.47 | 6.84 | | |
| 15+20 | 75 | 0 | 100 | 0 | QPSK | 19.10 | 19.20 | 19.36 | 18.92 | 0.0780 |
| 15+20 | 1 | 0 | 1 | 99 | | 8.52 | 8.69 | 8.77 | | |
| 15+20 | 1 | 74 | 1 | 0 | | 8.48 | 8.57 | 8.77 | | |
| 15+20 | 75 | 0 | 100 | 0 | 16-QAM | 18.11 | 18.21 | 18.30 | 17.86 | 0.0611 |
| 15+20 | 1 | 0 | 1 | 99 | | 8.85 | 9.30 | 9.54 | | |
| 15+20 | 1 | 74 | 1 | 0 | | 9.22 | 8.91 | 9.36 | | |
| 15+20 | 75 | 0 | 100 | 0 | 64-QAM | 18.09 | 18.23 | 18.33 | 17.89 | 0.0615 |
| 15+20 | 1 | 0 | 1 | 99 | | 7.78 | 8.15 | 8.20 | | |
| 15+20 | 1 | 74 | 1 | 0 | | 7.92 | 8.26 | 8.28 | | |
| 15+20 | 75 | 0 | 100 | 0 | 256-QAM | 17.06 | 17.26 | 17.32 | 16.88 | 0.0488 |
| 15+20 | 1 | 0 | 1 | 99 | | 6.56 | 6.84 | 6.86 | | |
| 15+20 | 1 | 74 | 1 | 0 | | 6.52 | 6.64 | 6.74 | | |
| Limit | EIRP < 2W | | | | | Result | | | Pass | |



| LTE Band 41C_CA Maximum Average Power [dBm] (GT - LC = -0.44 dB) | | | | | | | | | | |
|--|-----------|-----------|---------|-----------|---------|--------|--------|---------|------------|----------|
| BW [MHz] | PCC | | SCC | | Mod | Lowest | Middle | Highest | EIRP (dBm) | EIRP (W) |
| | RB Size | RB Offset | RB Size | RB Offset | | | | | | |
| 20+10 | 100 | 0 | 50 | 0 | QPSK | 18.95 | 19.08 | 19.24 | 18.80 | 0.0759 |
| 20+10 | 1 | 0 | 1 | 49 | | 8.34 | 8.62 | 8.70 | | |
| 20+10 | 1 | 99 | 1 | 0 | | 8.33 | 8.42 | 8.63 | | |
| 20+10 | 100 | 0 | 50 | 0 | 16-QAM | 17.96 | 18.16 | 18.28 | 17.84 | 0.0608 |
| 20+10 | 1 | 0 | 1 | 49 | | 8.90 | 9.45 | 9.40 | | |
| 20+10 | 1 | 99 | 1 | 0 | | 8.77 | 9.16 | 9.27 | | |
| 20+10 | 100 | 0 | 50 | 0 | 64-QAM | 17.97 | 18.10 | 18.22 | 17.78 | 0.0600 |
| 20+10 | 1 | 0 | 1 | 49 | | 7.61 | 8.16 | 8.25 | | |
| 20+10 | 1 | 99 | 1 | 0 | | 7.86 | 7.82 | 8.16 | | |
| 20+10 | 100 | 0 | 50 | 0 | 256-QAM | 17.18 | 17.29 | 17.43 | 16.99 | 0.0500 |
| 20+10 | 1 | 0 | 1 | 49 | | 6.50 | 6.76 | 6.86 | | |
| 20+10 | 1 | 99 | 1 | 0 | | 6.53 | 6.60 | 7.04 | | |
| 10+20 | 50 | 0 | 100 | 0 | QPSK | 18.96 | 19.25 | 19.28 | 18.84 | 0.0766 |
| 10+20 | 1 | 0 | 1 | 99 | | 8.33 | 8.57 | 8.64 | | |
| 10+20 | 1 | 49 | 1 | 0 | | 8.32 | 8.47 | 8.55 | | |
| 10+20 | 50 | 0 | 100 | 0 | 16-QAM | 17.98 | 18.16 | 18.26 | 17.82 | 0.0605 |
| 10+20 | 1 | 0 | 1 | 99 | | 8.94 | 9.27 | 9.29 | | |
| 10+20 | 1 | 49 | 1 | 0 | | 8.93 | 9.24 | 9.32 | | |
| 10+20 | 50 | 0 | 100 | 0 | 64-QAM | 17.93 | 18.03 | 18.19 | 17.75 | 0.0596 |
| 10+20 | 1 | 0 | 1 | 99 | | 7.88 | 7.83 | 8.08 | | |
| 10+20 | 1 | 49 | 1 | 0 | | 7.66 | 7.78 | 8.06 | | |
| 10+20 | 50 | 0 | 100 | 0 | 256-QAM | 17.17 | 17.31 | 17.43 | 16.99 | 0.0500 |
| 10+20 | 1 | 0 | 1 | 99 | | 6.77 | 7.08 | 6.63 | | |
| 10+20 | 1 | 49 | 1 | 0 | | 6.58 | 6.81 | 6.75 | | |
| 20+5 | 100 | 0 | 25 | 0 | QPSK | 19.02 | 19.18 | 19.36 | 18.92 | 0.0780 |
| 20+5 | 1 | 0 | 1 | 24 | | 8.39 | 8.71 | 8.79 | | |
| 20+5 | 1 | 99 | 1 | 0 | | 8.40 | 8.48 | 8.70 | | |
| 20+5 | 100 | 0 | 25 | 0 | 16-QAM | 18.05 | 18.23 | 18.32 | 17.88 | 0.0614 |
| 20+5 | 1 | 0 | 1 | 24 | | 9.17 | 9.54 | 9.58 | | |
| 20+5 | 1 | 99 | 1 | 0 | | 9.03 | 9.10 | 9.55 | | |
| 20+5 | 100 | 0 | 25 | 0 | 64-QAM | 18.02 | 18.20 | 18.32 | 17.88 | 0.0614 |
| 20+5 | 1 | 0 | 1 | 24 | | 7.71 | 7.98 | 8.27 | | |
| 20+5 | 1 | 99 | 1 | 0 | | 7.75 | 7.87 | 8.22 | | |
| 20+5 | 100 | 0 | 25 | 0 | 256-QAM | 17.13 | 17.26 | 17.44 | 17.00 | 0.0501 |
| 20+5 | 1 | 0 | 1 | 24 | | 6.75 | 6.81 | 6.88 | | |
| 20+5 | 1 | 99 | 1 | 0 | | 6.58 | 6.77 | 7.34 | | |
| Limit | EIRP < 2W | | | | | Result | | | Pass | |



| LTE Band 41C_CA Maximum Average Power [dBm] (GT - LC = -0.44 dB) | | | | | | | | | | |
|--|-----------|-----------|---------|-----------|---------|--------|--------|---------|------------|----------|
| BW [MHz] | PCC | | SCC | | Mod | Lowest | Middle | Highest | EIRP (dBm) | EIRP (W) |
| | RB Size | RB Offset | RB Size | RB Offset | | | | | | |
| 5+20 | 25 | 0 | 100 | 0 | QPSK | 19.00 | 19.14 | 19.24 | 18.80 | 0.0759 |
| 5+20 | 1 | 0 | 1 | 99 | | 8.40 | 8.55 | 8.64 | | |
| 5+20 | 1 | 24 | 1 | 0 | | 8.31 | 8.50 | 8.67 | | |
| 5+20 | 25 | 0 | 100 | 0 | 16-QAM | 18.07 | 18.28 | 18.39 | 17.95 | 0.0624 |
| 5+20 | 1 | 0 | 1 | 99 | | 8.70 | 9.20 | 9.39 | | |
| 5+20 | 1 | 24 | 1 | 0 | | 8.94 | 8.82 | 9.30 | | |
| 5+20 | 25 | 0 | 100 | 0 | 64-QAM | 18.05 | 18.18 | 18.29 | 17.85 | 0.0610 |
| 5+20 | 1 | 0 | 1 | 99 | | 7.69 | 7.86 | 8.06 | | |
| 5+20 | 1 | 24 | 1 | 0 | | 7.58 | 7.73 | 8.09 | | |
| 5+20 | 25 | 0 | 100 | 0 | 256-QAM | 17.13 | 17.31 | 17.38 | 16.94 | 0.0494 |
| 5+20 | 1 | 0 | 1 | 99 | | 6.43 | 7.02 | 6.65 | | |
| 5+20 | 1 | 24 | 1 | 0 | | 6.40 | 6.65 | 6.69 | | |
| 15+10 | 75 | 0 | 50 | 0 | QPSK | 18.96 | 19.11 | 19.24 | 18.80 | 0.0759 |
| 15+10 | 1 | 0 | 1 | 49 | | 8.32 | 8.62 | 8.68 | | |
| 15+10 | 1 | 74 | 1 | 0 | | 8.33 | 8.50 | 8.66 | | |
| 15+10 | 75 | 0 | 50 | 0 | 16-QAM | 17.99 | 18.12 | 18.26 | 17.82 | 0.0605 |
| 15+10 | 1 | 0 | 1 | 49 | | 8.64 | 9.11 | 9.30 | | |
| 15+10 | 1 | 74 | 1 | 0 | | 8.82 | 9.08 | 9.35 | | |
| 15+10 | 75 | 0 | 50 | 0 | 64-QAM | 17.95 | 18.16 | 18.25 | 17.81 | 0.0604 |
| 15+10 | 1 | 0 | 1 | 49 | | 7.62 | 7.90 | 8.15 | | |
| 15+10 | 1 | 74 | 1 | 0 | | 7.72 | 7.91 | 8.34 | | |
| 15+10 | 75 | 0 | 50 | 0 | 256-QAM | 17.13 | 17.30 | 17.42 | 16.98 | 0.0499 |
| 15+10 | 1 | 0 | 1 | 49 | | 6.48 | 6.77 | 7.09 | | |
| 15+10 | 1 | 74 | 1 | 0 | | 6.56 | 6.61 | 7.08 | | |
| 10+15 | 50 | 0 | 75 | 0 | QPSK | 18.99 | 19.15 | 19.26 | 18.82 | 0.0762 |
| 10+15 | 1 | 0 | 1 | 74 | | 8.34 | 8.56 | 8.66 | | |
| 10+15 | 1 | 49 | 1 | 0 | | 8.30 | 8.50 | 8.67 | | |
| 10+15 | 50 | 0 | 75 | 0 | 16-QAM | 17.99 | 18.16 | 18.30 | 17.86 | 0.0611 |
| 10+15 | 1 | 0 | 1 | 74 | | 8.79 | 11.31 | 9.34 | | |
| 10+15 | 1 | 49 | 1 | 0 | | 9.07 | 9.29 | 9.30 | | |
| 10+15 | 50 | 0 | 75 | 0 | 64-QAM | 17.96 | 18.16 | 18.26 | 17.82 | 0.0605 |
| 10+15 | 1 | 0 | 1 | 74 | | 7.56 | 8.04 | 8.01 | | |
| 10+15 | 1 | 49 | 1 | 0 | | 7.48 | 7.68 | 7.86 | | |
| 10+15 | 50 | 0 | 75 | 0 | 256-QAM | 17.17 | 17.31 | 17.41 | 16.97 | 0.0498 |
| 10+15 | 1 | 0 | 1 | 74 | | 6.53 | 6.67 | 7.00 | | |
| 10+15 | 1 | 49 | 1 | 0 | | 6.57 | 6.91 | 7.08 | | |
| Limit | EIRP < 2W | | | | | Result | | | Pass | |



| LTE Band 41C_CA Maximum Average Power [dBm] (GT - LC = -0.44 dB) | | | | | | | | | | |
|--|-----------|-----------|---------|-----------|---------|--------|--------|---------|------------|----------|
| BW [MHz] | PCC | | SCC | | Mod | Lowest | Middle | Highest | EIRP (dBm) | EIRP (W) |
| | RB Size | RB Offset | RB Size | RB Offset | | | | | | |
| 15+15 | 75 | 0 | 75 | 0 | QPSK | 19.00 | 19.11 | 19.24 | 18.80 | 0.0759 |
| 15+15 | 1 | 0 | 1 | 74 | | 8.36 | 8.56 | 8.72 | | |
| 15+15 | 1 | 74 | 1 | 0 | | 8.40 | 8.47 | 8.74 | | |
| 15+15 | 75 | 0 | 75 | 0 | 16-QAM | 17.95 | 18.10 | 18.25 | 17.81 | 0.0604 |
| 15+15 | 1 | 0 | 1 | 74 | | 9.01 | 9.36 | 9.26 | | |
| 15+15 | 1 | 74 | 1 | 0 | | 9.10 | 9.26 | 9.47 | | |
| 15+15 | 75 | 0 | 75 | 0 | 64-QAM | 17.99 | 18.09 | 18.28 | 17.84 | 0.0608 |
| 15+15 | 1 | 0 | 1 | 74 | | 7.54 | 7.95 | 8.15 | | |
| 15+15 | 1 | 74 | 1 | 0 | | 7.79 | 7.85 | 8.26 | | |
| 15+15 | 75 | 0 | 75 | 0 | 256-QAM | 17.10 | 17.29 | 17.38 | 16.94 | 0.0494 |
| 15+15 | 1 | 0 | 1 | 74 | | 6.64 | 6.88 | 6.84 | | |
| 15+15 | 1 | 74 | 1 | 0 | | 6.82 | 6.77 | 6.79 | | |
| Limit | EIRP < 2W | | | | | Result | | | Pass | |



LTE Band 5B

26dB Bandwidth

| Mode | LTE Band 5B : 26dB BW(MHz) | | |
|-----------|----------------------------|-------------|------------|
| QPSK | | | |
| BW | 3MHz+5MHz | 5MHz+3MHz | 5MHz+10MHz |
| Middle CH | 8.12 | 8.36 | 14.90 |
| BW | 10MHz+5MHz | 10MHz+10MHz | N/A |
| Middle CH | 14.93 | 19.98 | - |

| Mode | LTE Band 5B : 26dB BW(MHz) | | |
|-----------|----------------------------|-------------|------------|
| 16QAM | | | |
| BW | 3MHz+5MHz | 5MHz+3MHz | 5MHz+10MHz |
| Middle CH | 8.20 | 8.31 | 14.93 |
| BW | 10MHz+5MHz | 10MHz+10MHz | N/A |
| Middle CH | 14.72 | 20.42 | - |

| Mode | LTE Band 5B : 26dB BW(MHz) | | |
|-----------|----------------------------|-------------|------------|
| 64QAM | | | |
| BW | 3MHz+5MHz | 5MHz+3MHz | 5MHz+10MHz |
| Middle CH | 8.14 | 8.10 | 14.99 |
| BW | 10MHz+5MHz | 10MHz+10MHz | N/A |
| Middle CH | 14.87 | 19.82 | - |

| Mode | LTE Band 5B : 26dB BW(MHz) | | |
|-----------|----------------------------|-------------|------------|
| 256QAM | | | |
| BW | 3MHz+5MHz | 5MHz+3MHz | 5MHz+10MHz |
| Middle CH | 8.09 | 8.20 | 14.75 |
| BW | 10MHz+5MHz | 10MHz+10MHz | N/A |
| Middle CH | 14.78 | 19.54 | - |



LTE Band 5B

QPSK

Middle Channel / 3MHz+5MHz

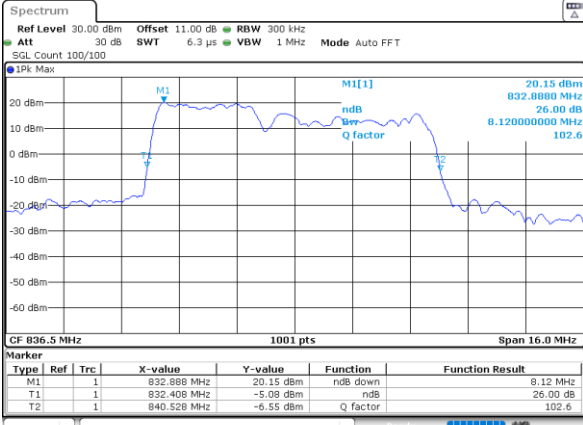

Date: 2.DEC.2022 04:12:40

Middle Channel / 5MHz+3MHz

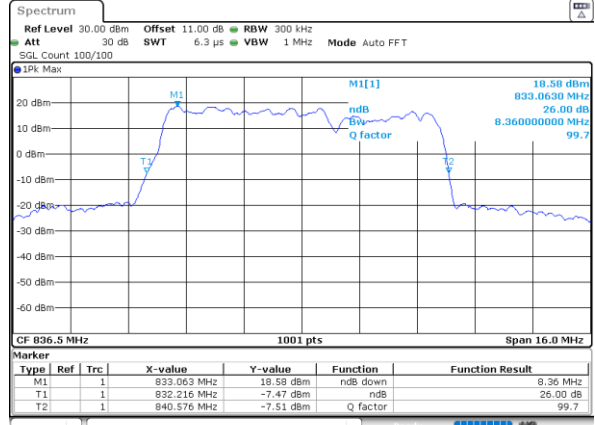

Date: 2.DEC.2022 04:59:22

Middle Channel / 5MHz+10MHz

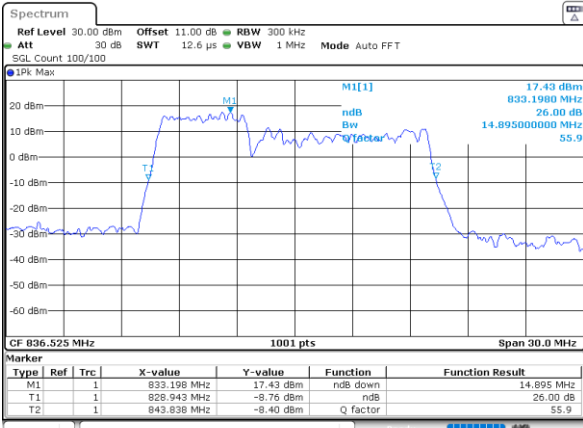

Date: 2.DEC.2022 05:41:28

Middle Channel / 10MHz+5MHz

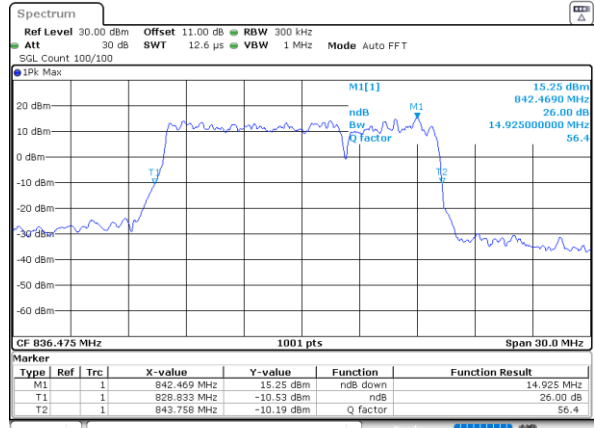

Date: 2.DEC.2022 06:27:10

Middle Channel / 10MHz+10MHz

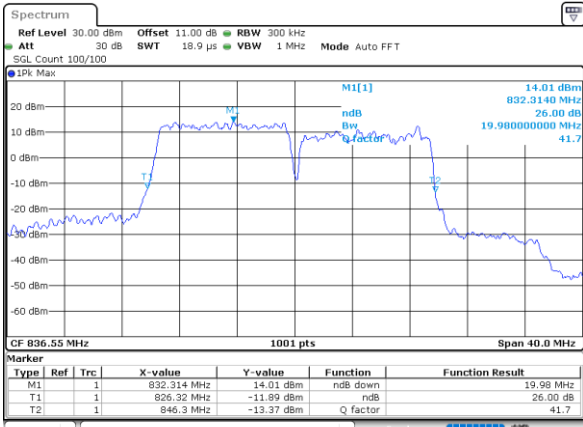

Date: 18.JAN.2023 17:46:26

N/A



LTE Band 5B

16QAM

Middle Channel / 3MHz+5MHz

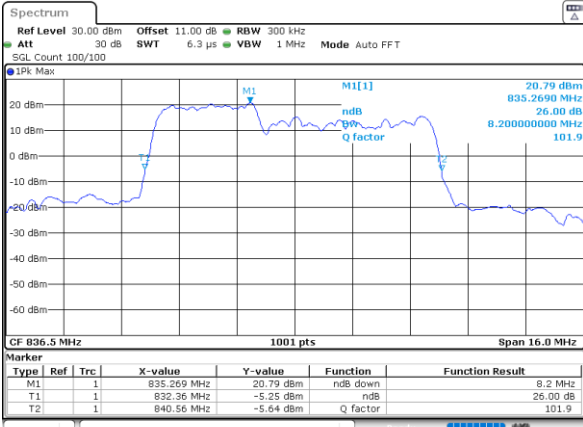

Date: 2.DEC.2022 04:06:42

Middle Channel / 5MHz+3MHz

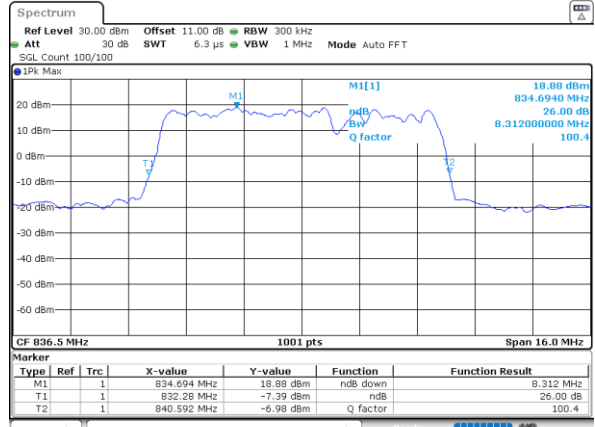

Date: 2.DEC.2022 04:57:44

Middle Channel / 5MHz+10MHz

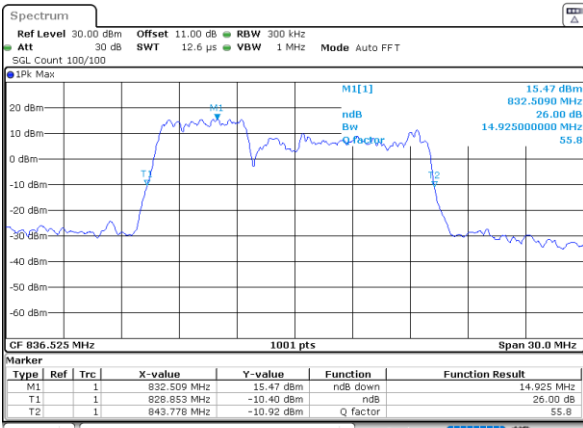

Date: 2.DEC.2022 05:10:50

Middle Channel / 10MHz+5MHz

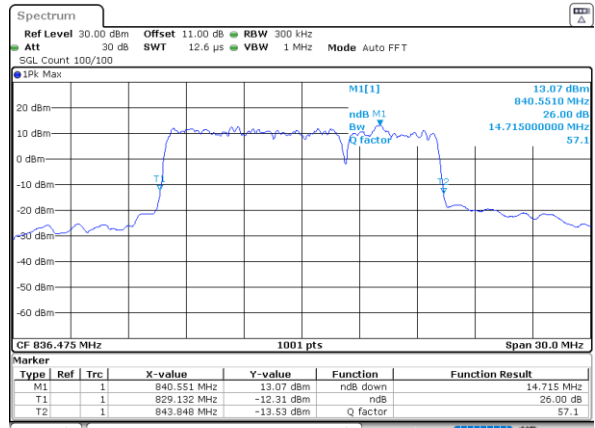

Date: 2.DEC.2022 06:26:00

Middle Channel / 10MHz+10MHz

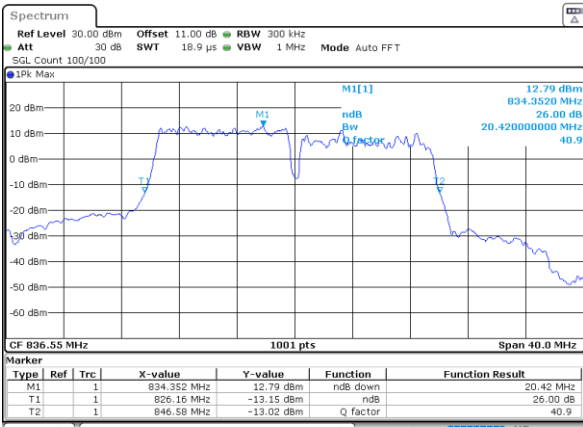

Date: 2.DEC.2022 06:15:52

N/A



LTE Band 5B

64QAM

Middle Channel / 3MHz+5MHz

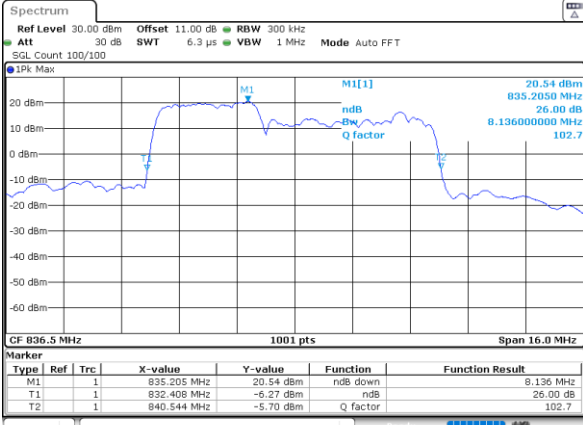

Date: 2.DEC.2022 04:04:22

Middle Channel / 5MHz+3MHz

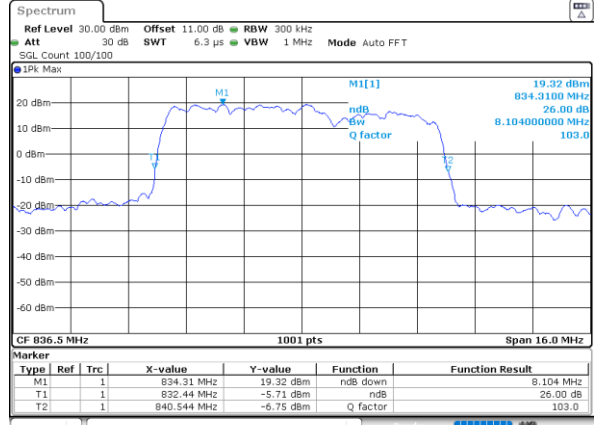

Date: 2.DEC.2022 04:57:06

Middle Channel / 5MHz+10MHz

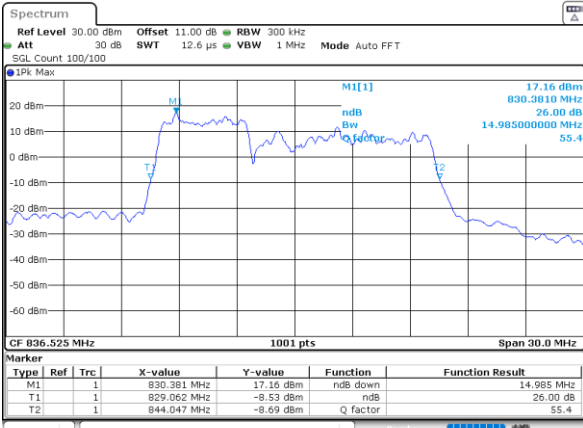

Date: 2.DEC.2022 05:40:12

Middle Channel / 10MHz+5MHz

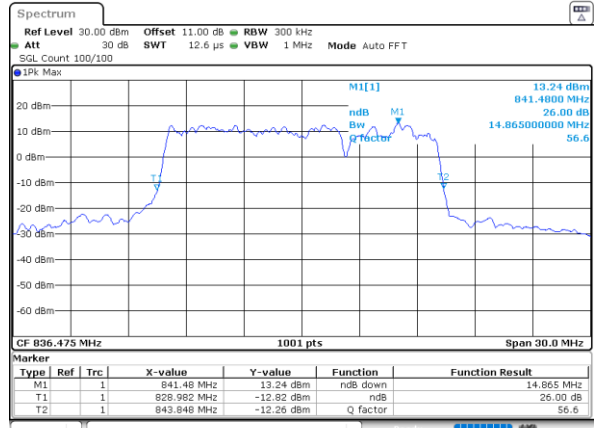

Date: 2.DEC.2022 06:25:21

Middle Channel / 10MHz+10MHz

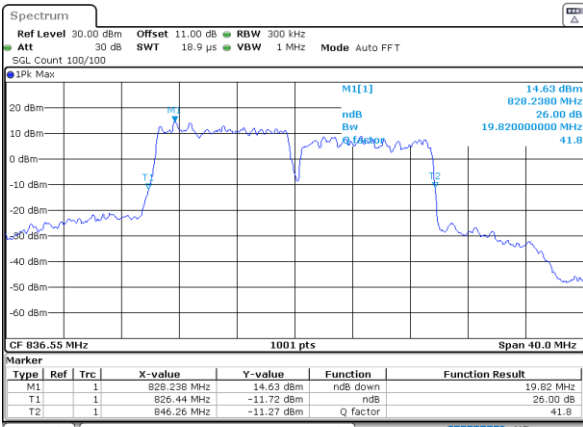

Date: 2.DEC.2022 06:59:19

N/A



LTE Band 5B

256QAM

Middle Channel / 3MHz+5MHz

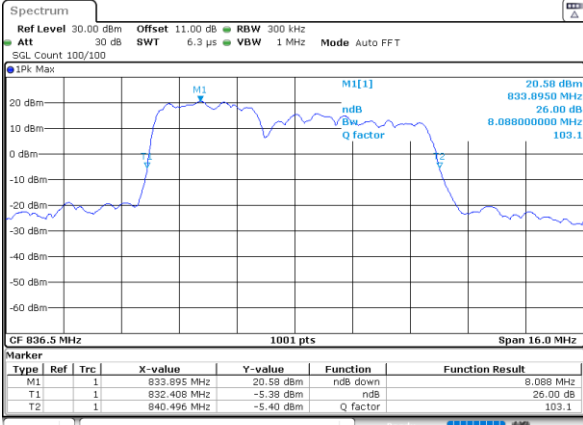

Date: 2.DEC.2022 07:32:47

Middle Channel / 5MHz+3MHz

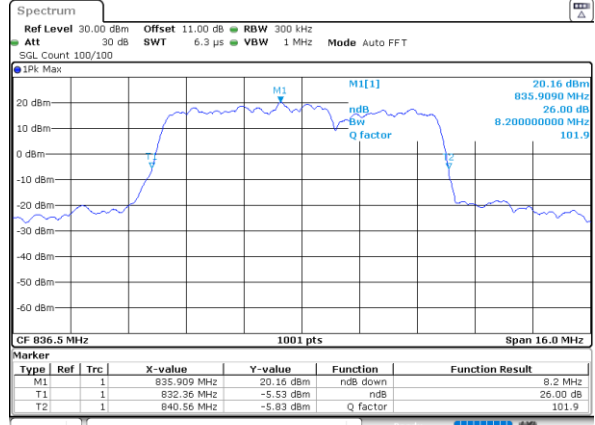

Date: 2.DEC.2022 07:41:19

Middle Channel / 5MHz+10MHz

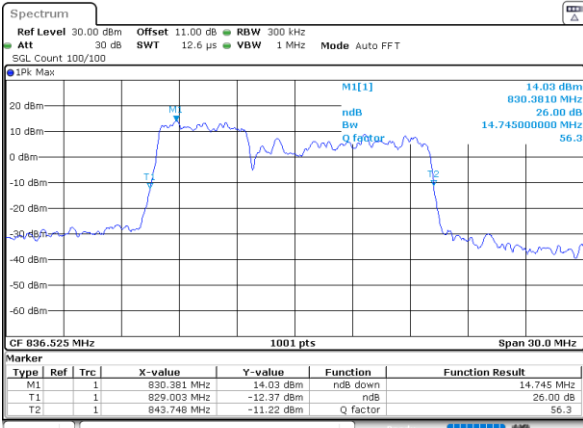

Date: 2.DEC.2022 07:52:01

Middle Channel / 10MHz+5MHz

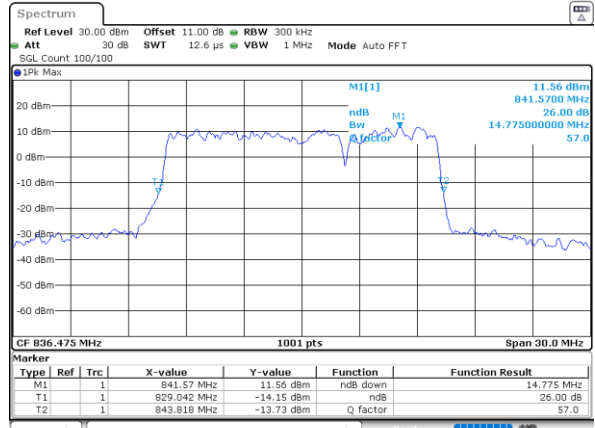

Date: 2.DEC.2022 08:05:00

Middle Channel / 10MHz+10MHz

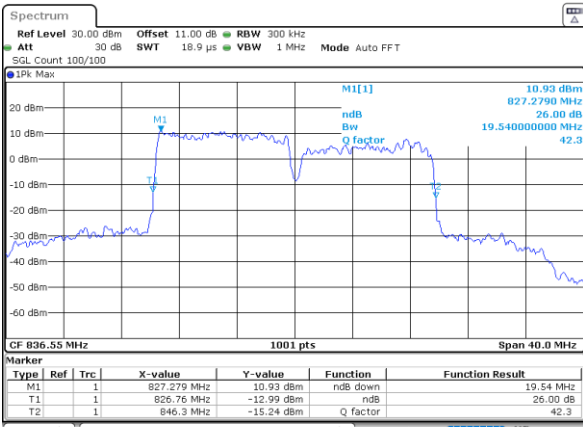

Date: 2.DEC.2022 08:13:41

N/A



Occupied Bandwidth

| Mode | LTE Band 5B : 99%OBW(MHz) | | |
|-----------|---------------------------|-------------|------------|
| QPSK | | | |
| BW | 3MHz+5MHz | 5MHz+3MHz | 5MHz+10MHz |
| Middle CH | 7.54 | 7.53 | 13.91 |
| BW | 10MHz+5MHz | 10MHz+10MHz | N/A |
| Middle CH | 13.79 | 18.82 | - |

| Mode | LTE Band 5B : 99%OBW(MHz) | | |
|-----------|---------------------------|-------------|------------|
| 16QAM | | | |
| BW | 3MHz+5MHz | 5MHz+3MHz | 5MHz+10MHz |
| Middle CH | 7.42 | 7.53 | 13.82 |
| BW | 10MHz+5MHz | 10MHz+10MHz | N/A |
| Middle CH | 13.91 | 18.78 | - |

| Mode | LTE Band 5B : 99%OBW(MHz) | | |
|-----------|---------------------------|-------------|------------|
| 64QAM | | | |
| BW | 3MHz+5MHz | 5MHz+3MHz | 5MHz+10MHz |
| Middle CH | 7.48 | 7.59 | 13.91 |
| BW | 10MHz+5MHz | 10MHz+10MHz | N/A |
| Middle CH | 13.94 | 18.70 | - |

| Mode | LTE Band 5B : 99%OBW(MHz) | | |
|-----------|---------------------------|-------------|------------|
| 254QAM | | | |
| BW | 3MHz+5MHz | 5MHz+3MHz | 5MHz+10MHz |
| Middle CH | 7.56 | 7.51 | 13.88 |
| BW | 10MHz+5MHz | 10MHz+10MHz | N/A |
| Middle CH | 13.91 | 18.86 | - |



LTE Band 5B

QPSK

Middle Channel / 3MHz+5MHz

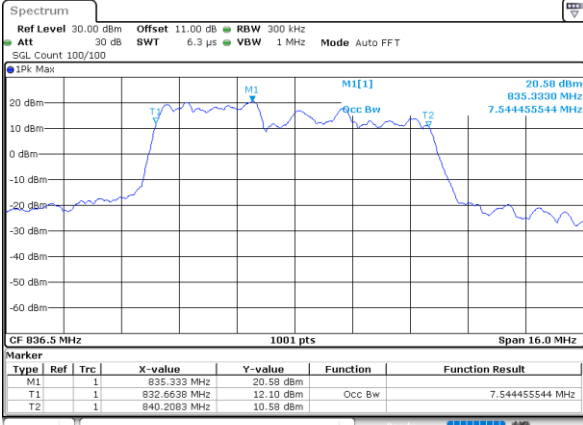

Date: 6, DEC, 2022 14:33:51

Middle Channel / 5MHz+3MHz

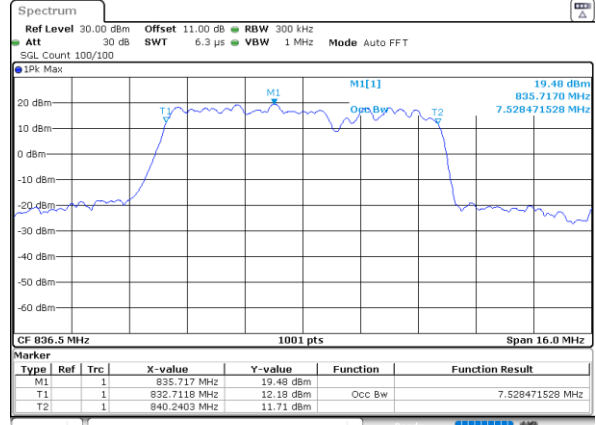

Date: 2, DEC, 2022 04:55:12

Middle Channel / 5MHz+10MHz

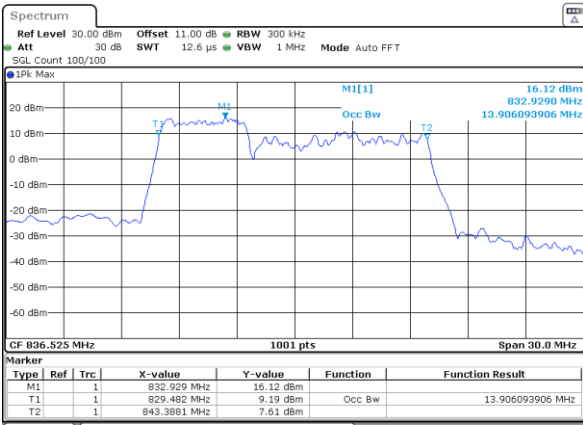

Date: 2, DEC, 2022 05:18:18

Middle Channel / 10MHz+5MHz

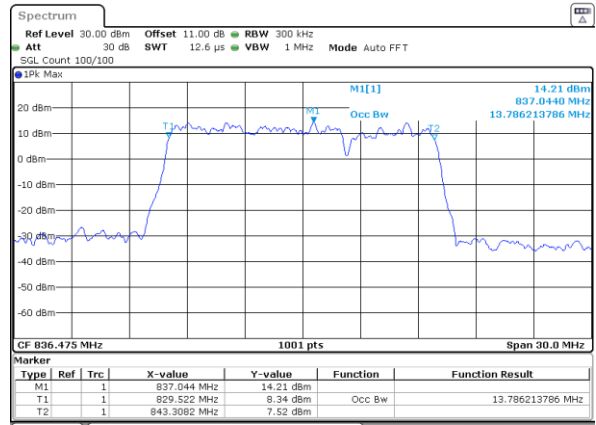

Date: 2, DEC, 2022 06:23:28

Middle Channel / 10MHz+10MHz

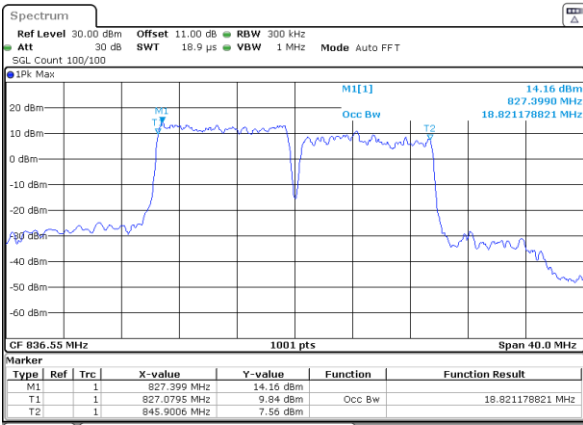

Date: 2, DEC, 2022 06:57:40

N/A



LTE Band 5B

16QAM

Middle Channel / 3MHz+5MHz

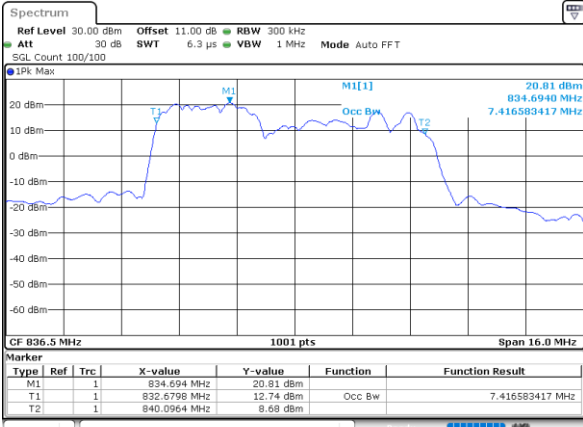

Date: 6.DEC.2022 14:34:30

Middle Channel / 5MHz+3MHz

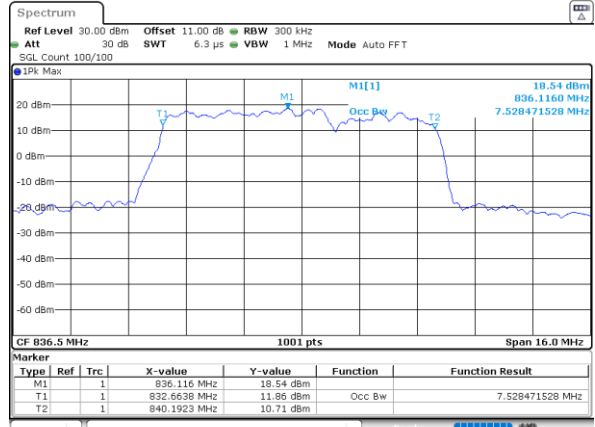

Date: 2.DEC.2022 04:55:50

Middle Channel / 5MHz+10MHz

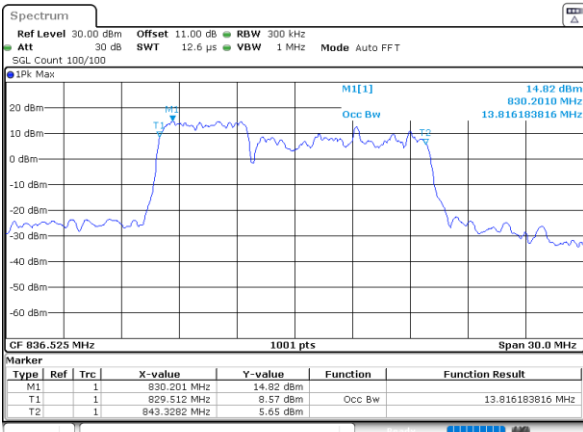

Date: 2.DEC.2022 05:13:56

Middle Channel / 10MHz+5MHz

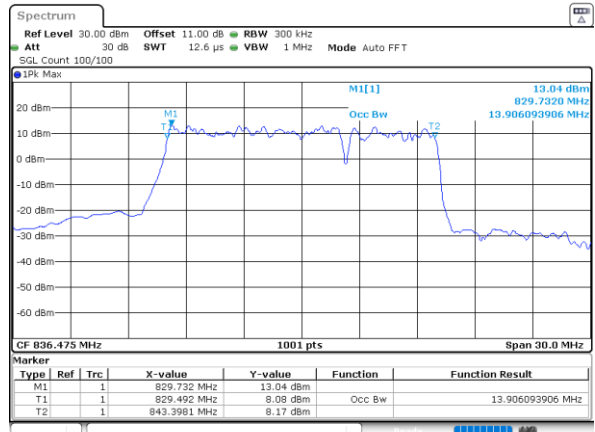

Date: 2.DEC.2022 06:24:06

Middle Channel / 10MHz+10MHz

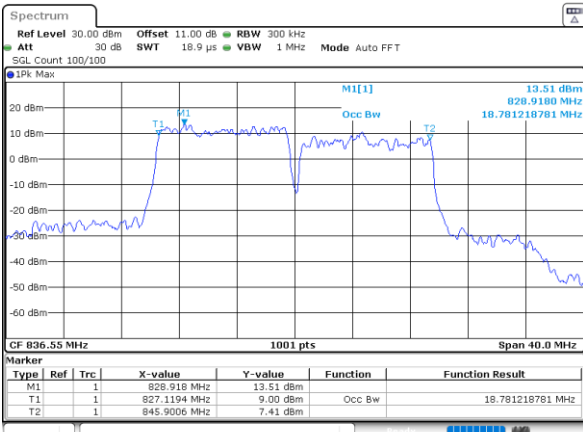

Date: 2.DEC.2022 06:15:13

N/A



LTE Band 5B

64QAM

Middle Channel / 3MHz+5MHz

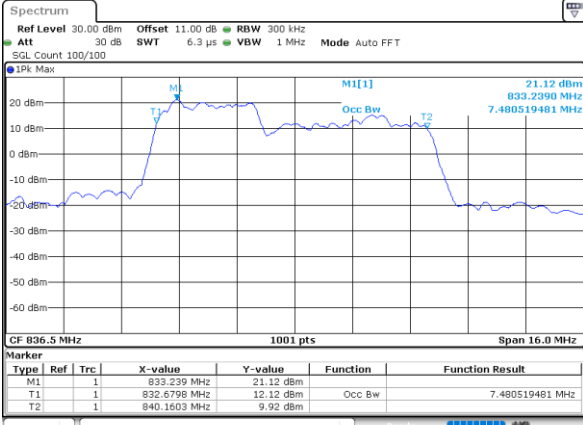

Date: 6, DEC, 2022 14:35:14

Middle Channel / 5MHz+3MHz

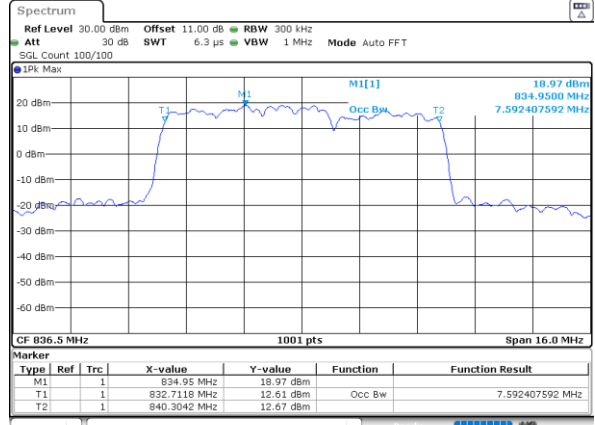

Date: 2, DEC, 2022 04:56:28

Middle Channel / 5MHz+10MHz

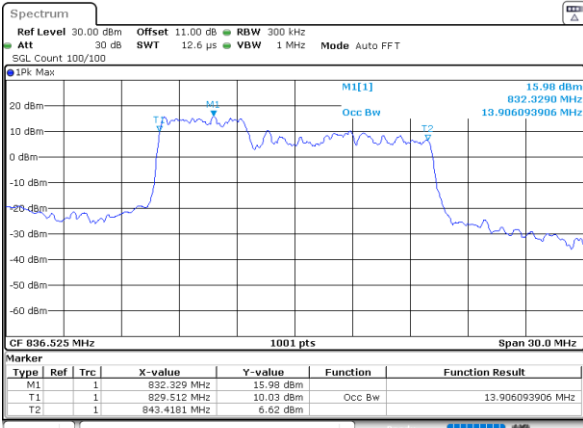

Date: 2, DEC, 2022 05:13:34

Middle Channel / 10MHz+5MHz

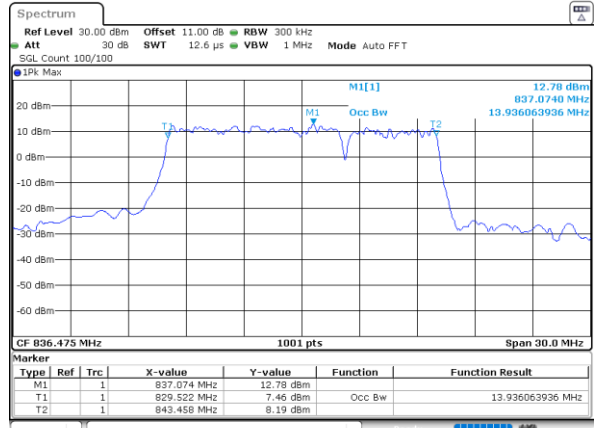

Date: 2, DEC, 2022 06:24:44

Middle Channel / 10MHz+10MHz

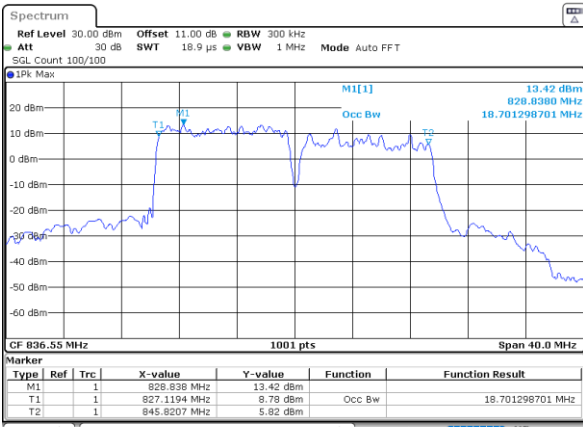

Date: 2, DEC, 2022 06:15:46

N/A



LTE Band 5B

256QAM

Middle Channel / 3MHz+5MHz

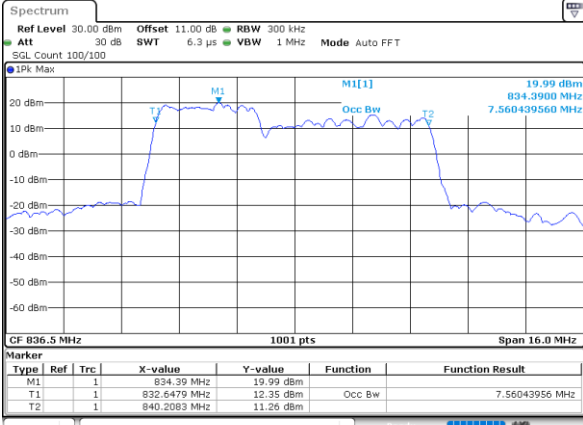

Date: 6.DEC.2022 14:35:58

Middle Channel / 5MHz+3MHz

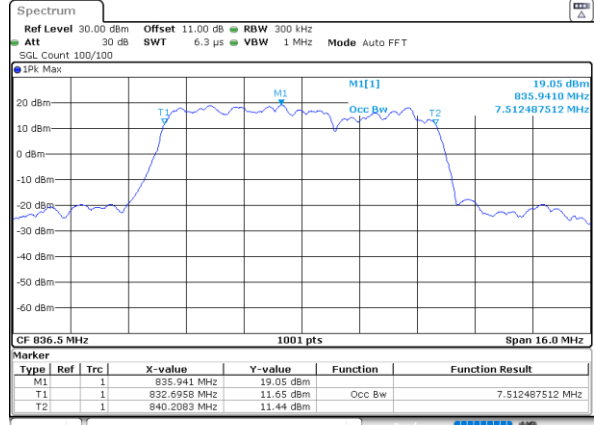

Date: 2.DEC.2022 07:40:41

Middle Channel / 5MHz+10MHz

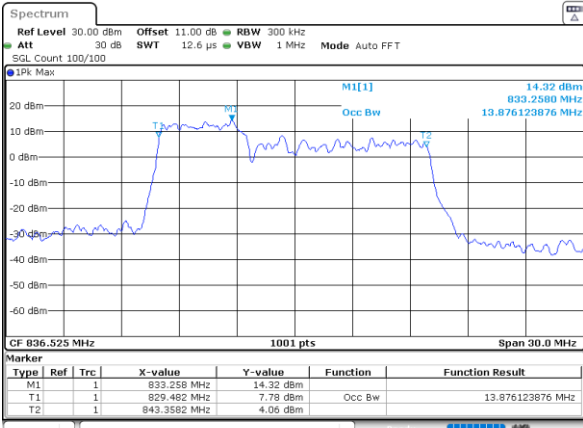

Date: 2.DEC.2022 07:50:52

Middle Channel / 10MHz+5MHz

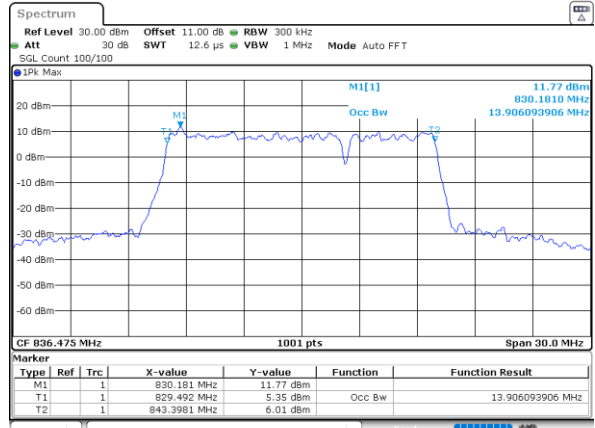

Date: 2.DEC.2022 08:10:22

Middle Channel / 10MHz+10MHz

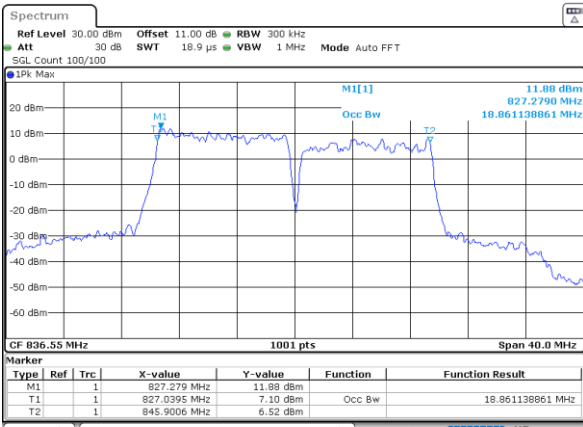

Date: 2.DEC.2022 08:13:09

N/A



Conducted Band Edge

LTE Band 5B / 3MHz+5MHz

QPSK

Lowest Band Edge / 1RB0 and 1RB24

Highest Band Edge / 1RB0 and 1RB24

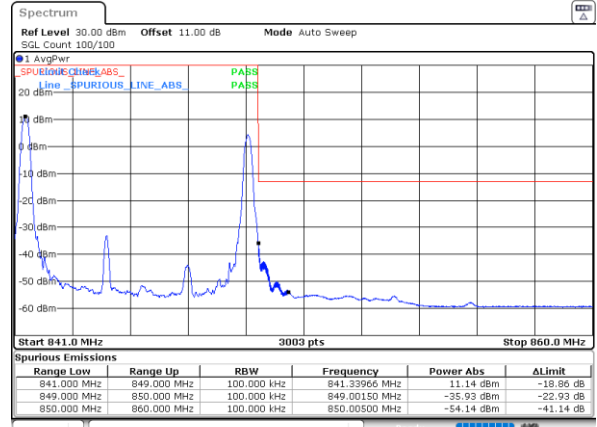
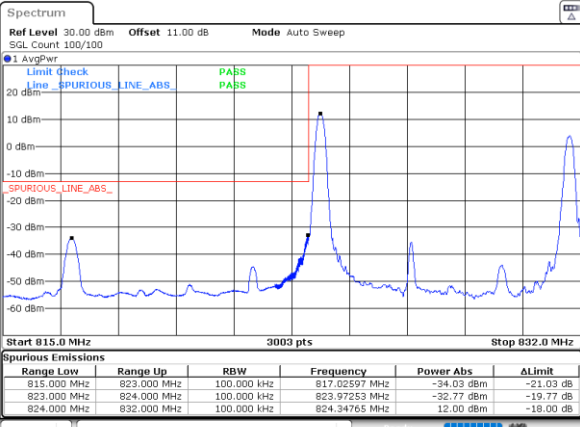

Date: 2, DEC, 2022 02:58:46

Date: 2, DEC, 2022 02:03:01

Lowest Band Edge / 1RB14 and 1RB0

Highest Band Edge / 1RB14 and 1RB0

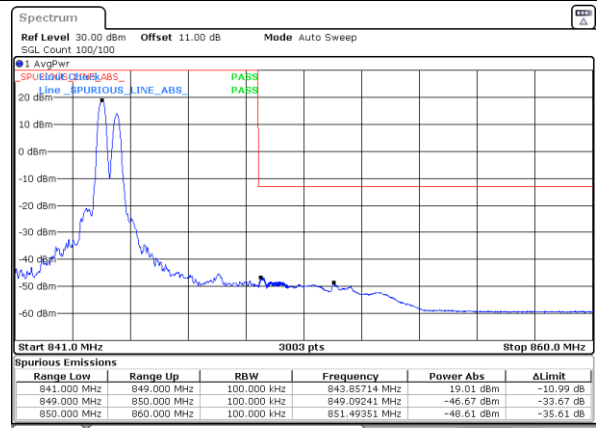
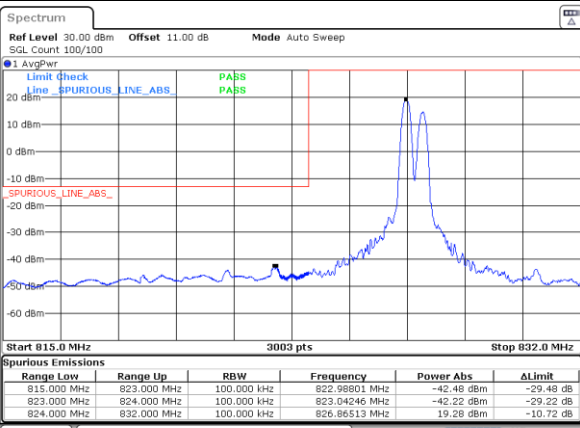

Date: 2, DEC, 2022 03:16:15

Date: 7, DEC, 2022 22:16:37

Lowest Band Edge / Full RB

Highest Band Edge / Full RB

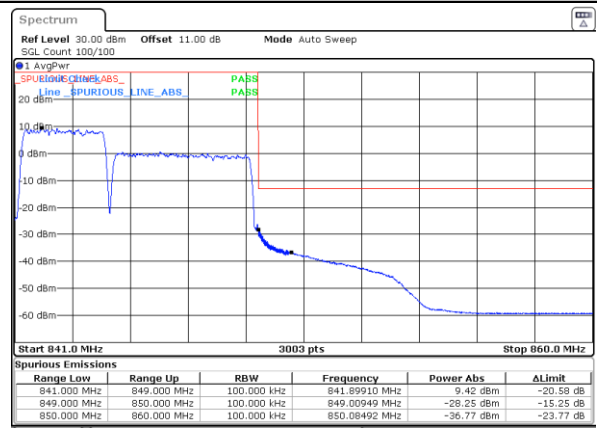
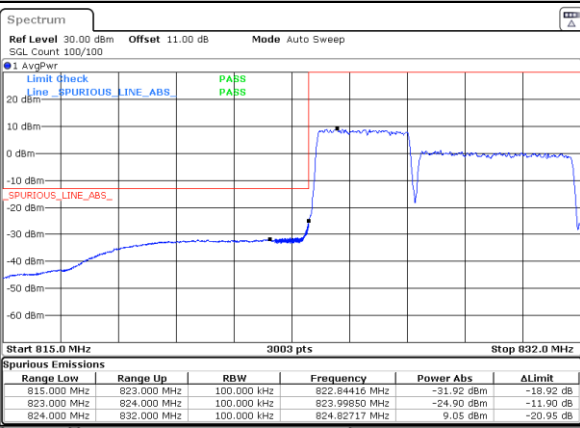

Date: 2, DEC, 2022 02:13:56

Date: 2, DEC, 2022 02:01:53



LTE Band 5B / 5MHz+3MHz

QPSK

Lowest Band Edge / 1RB0 and 1RB14

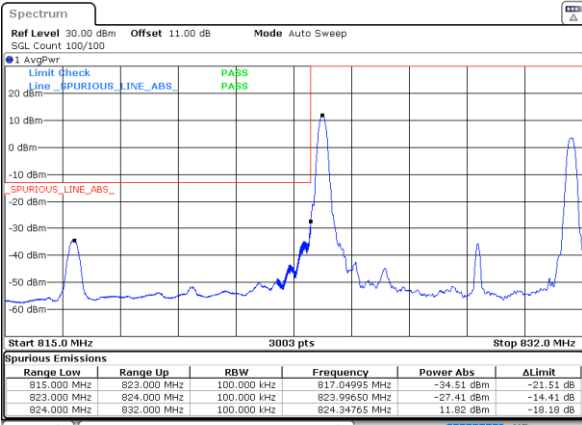

Date: 2.DEC.2022 04:44:58

Highest Band Edge / 1RB0 and 1RB14

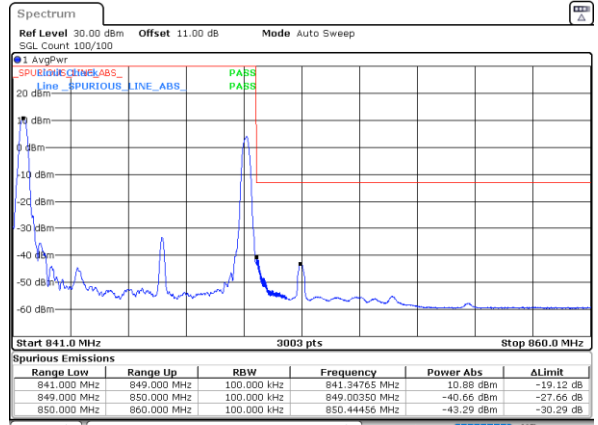

Date: 2.DEC.2022 22:30:43

Lowest Band Edge / 1RB24 and 1RB0

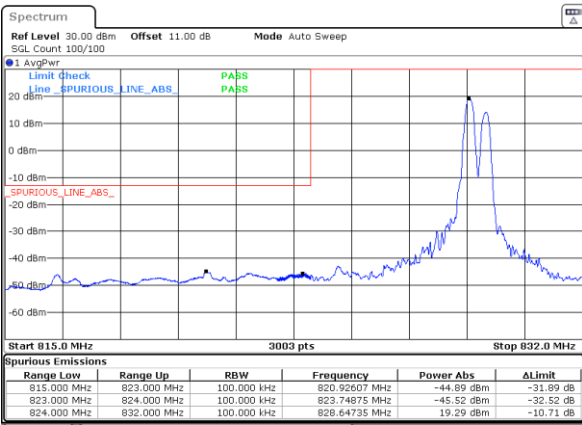

Date: 2.DEC.2022 04:46:06

Highest Band Edge / 1RB24 and 1RB0

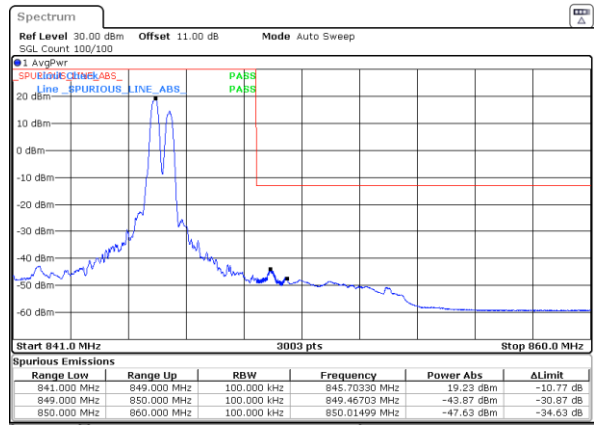

Date: 2.DEC.2022 04:31:34

Lowest Band Edge / Full RB

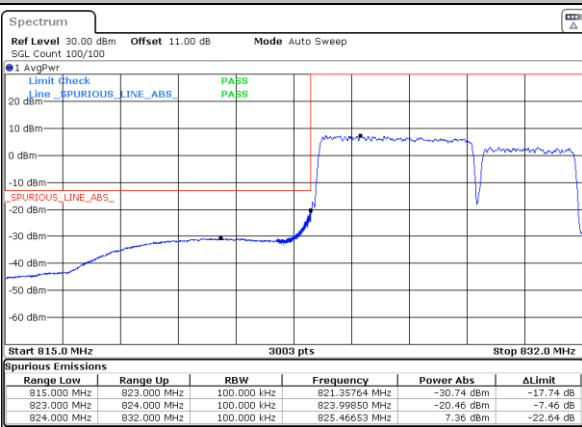

Date: 2.DEC.2022 04:39:15

Highest Band Edge / Full RB



Date: 2.DEC.2022 04:21:57



LTE Band 5B / 5MHz+10MHz

QPSK

Lowest Band Edge / 1RB0 and 1RB49

Highest Band Edge / 1RB0 and 1RB49

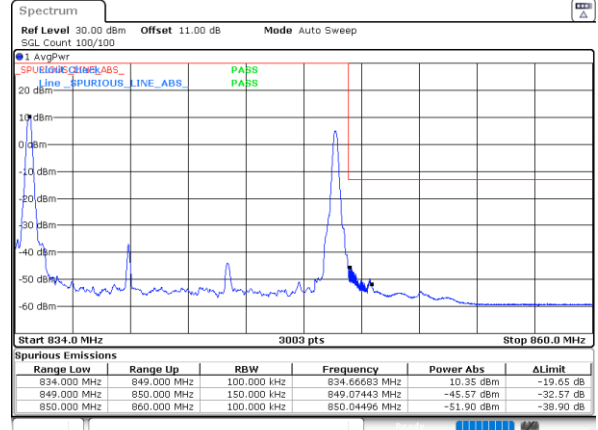

Date: 2, DEC, 2022 05:12:41

Date: 2, DEC, 2022 05:07:36

Lowest Band Edge / 1RB24 and 1RB0

Highest Band Edge / 1RB24 and 1RB0

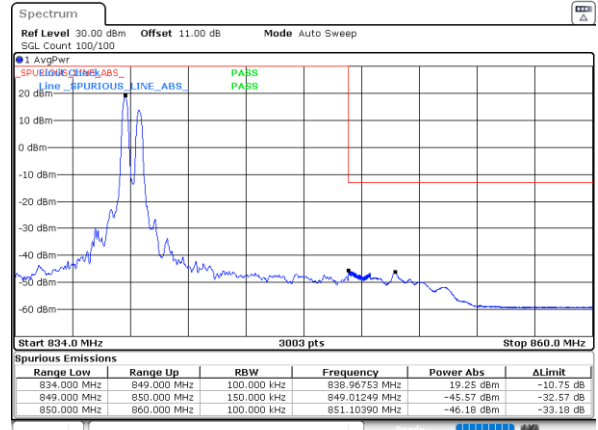
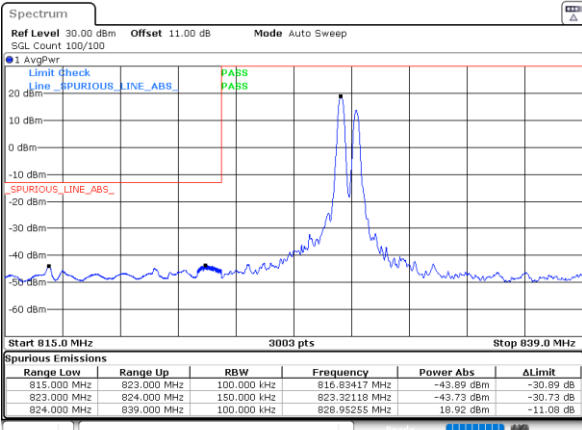

Date: 2, DEC, 2022 05:12:50

Date: 2, DEC, 2022 05:13:17

Lowest Band Edge / Full RB

Highest Band Edge / Full RB

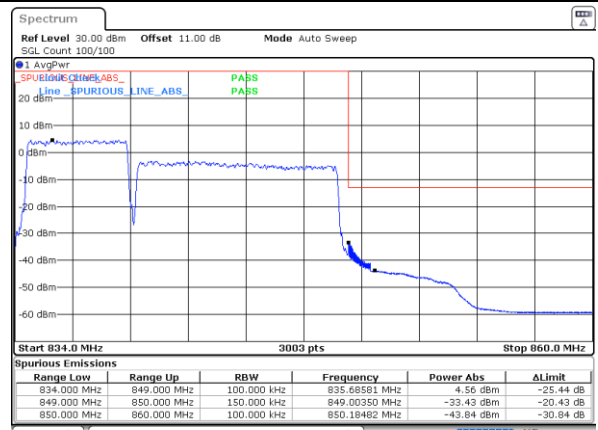
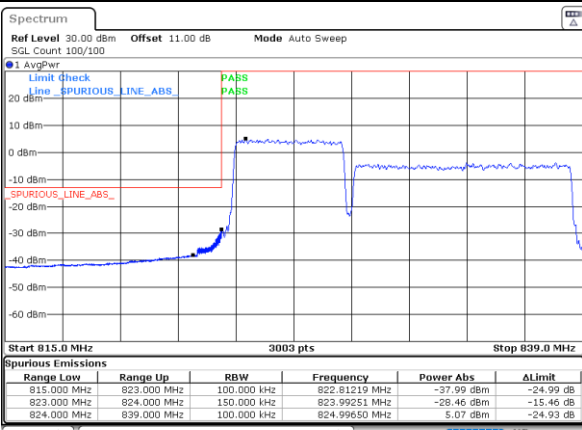

Date: 2, DEC, 2022 05:12:58

Date: 2, DEC, 2022 05:06:28



LTE Band 5B / 10MHz+5MHz

QPSK

Lowest Band Edge / 1RB0 and 1RB24

Highest Band Edge / 1RB0 and 1RB24

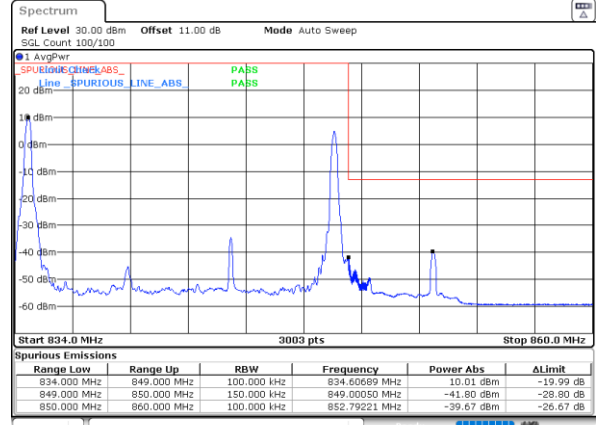
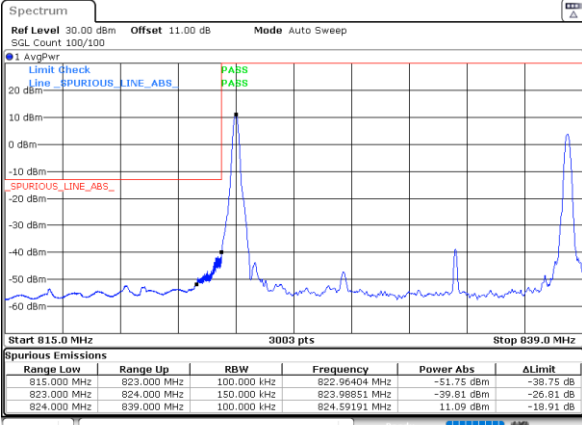

Date: 2, DEC, 2022 06:13:28

Date: 2, DEC, 2022 05:53:05

Lowest Band Edge / 1RB49 and 1RB0

Highest Band Edge / 1RB49 and 1RB0

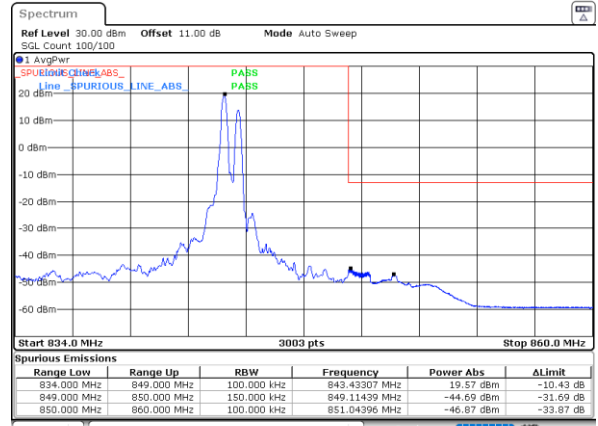
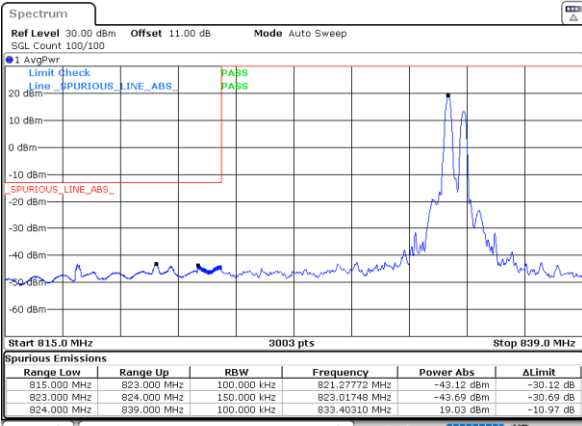

Date: 2, DEC, 2022 06:14:37

Date: 2, DEC, 2022 05:58:46

Lowest Band Edge / Full RB

Highest Band Edge / Full RB

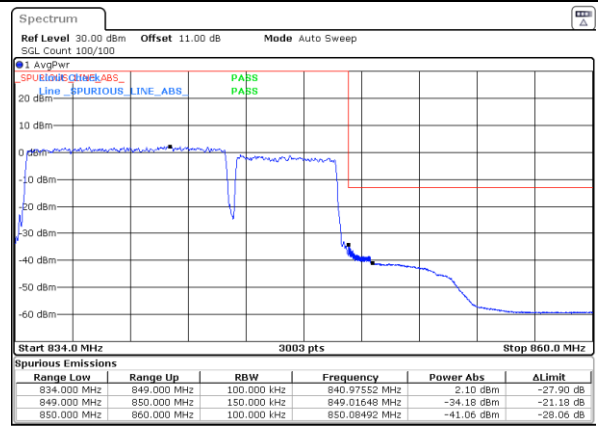
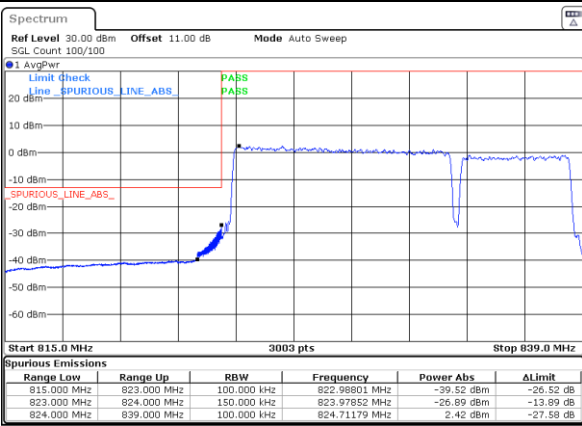

Date: 2, DEC, 2022 06:10:04

Date: 2, DEC, 2022 05:51:57



LTE Band 5B / 10MHz+10MHz

QPSK

Lowest Band Edge / 1RB0 and 1RB49

Highest Band Edge / 1RB0 and 1RB49

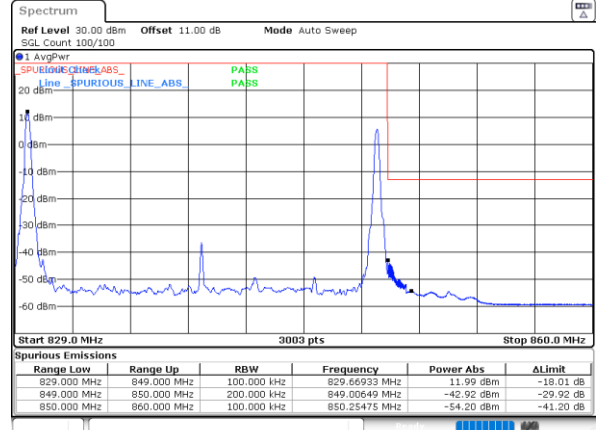
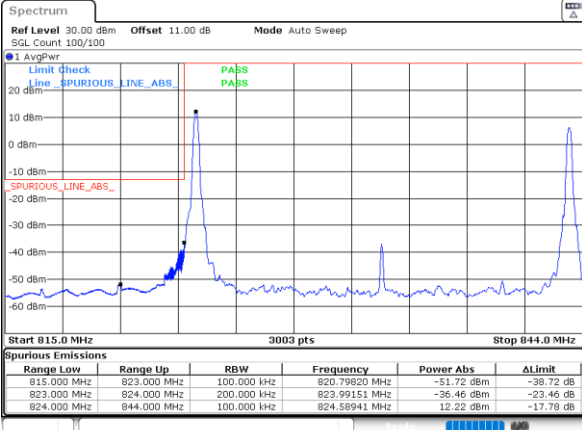

Date: 2.DEC.2022 06:49:19

Date: 2.DEC.2022 06:34:22

Lowest Band Edge / 1RB49 and 1RB0

Highest Band Edge / 1RB49 and 1RB0

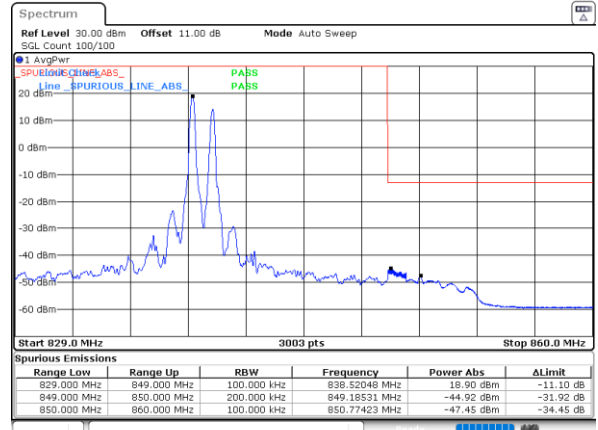
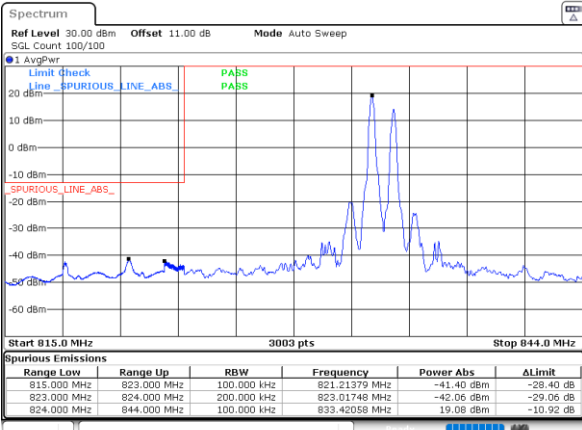

Date: 2.DEC.2022 06:50:22

Date: 2.DEC.2022 06:39:37

Lowest Band Edge / Full RB

Highest Band Edge / Full RB

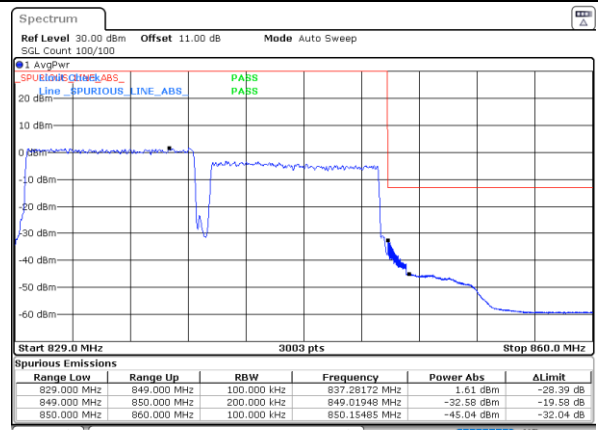
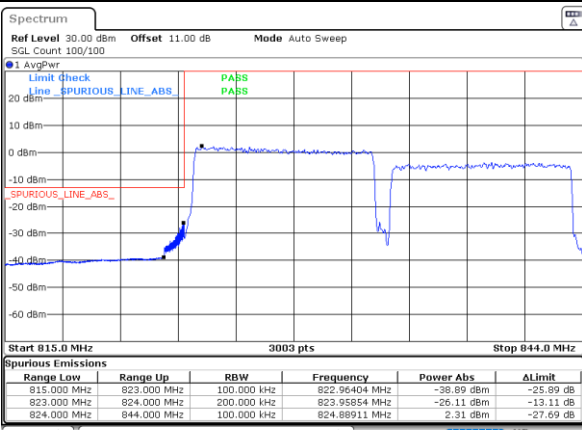

Date: 2.DEC.2022 06:44:03

Date: 2.DEC.2022 06:33:18



LTE Band 5B / 3MHz+5MHz

16QAM

Lowest Band Edge / 1RB0 and 1RB24

Highest Band Edge / 1RB0 and 1RB24

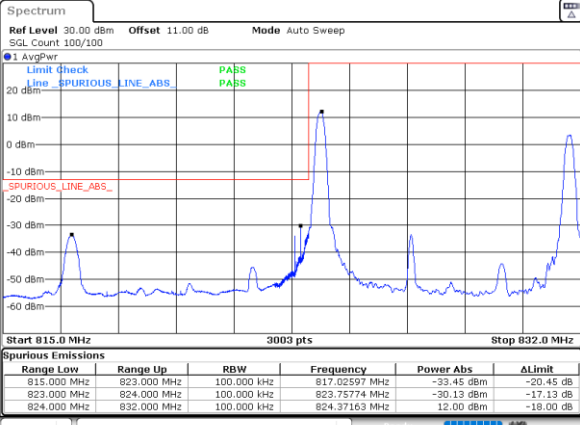

Date: 7.DEC.2022 22:20:01

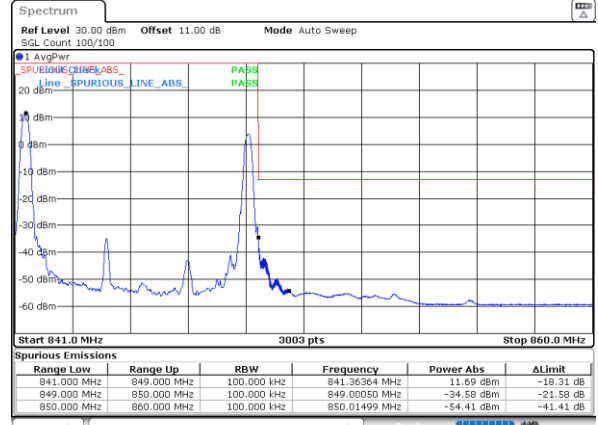

Date: 2.DEC.2022 02:05:51

Lowest Band Edge / 1RB14 and 1RB0

Highest Band Edge / 1RB14 and 1RB0

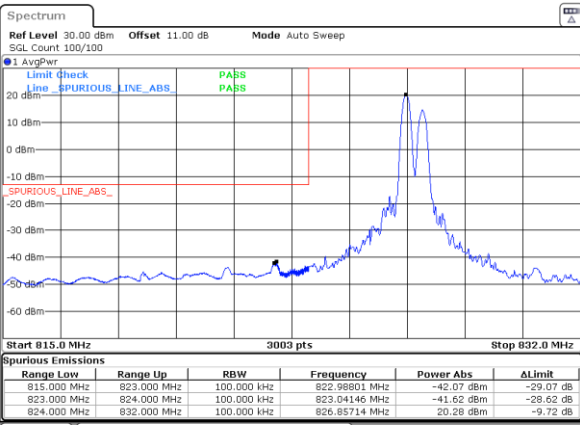

Date: 2.DEC.2022 03:27:00

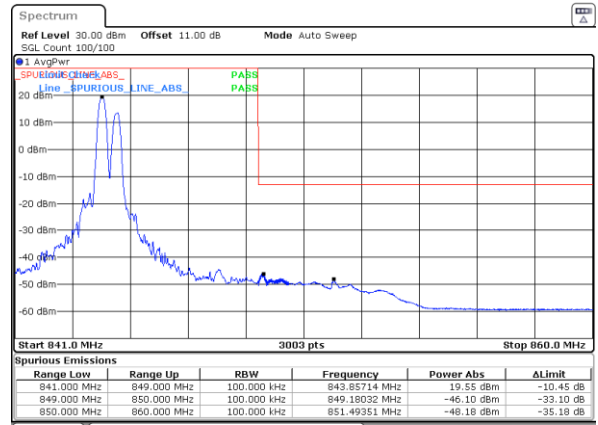

Date: 2.DEC.2022 02:14:44

Lowest Band Edge / Full RB

Highest Band Edge / Full RB

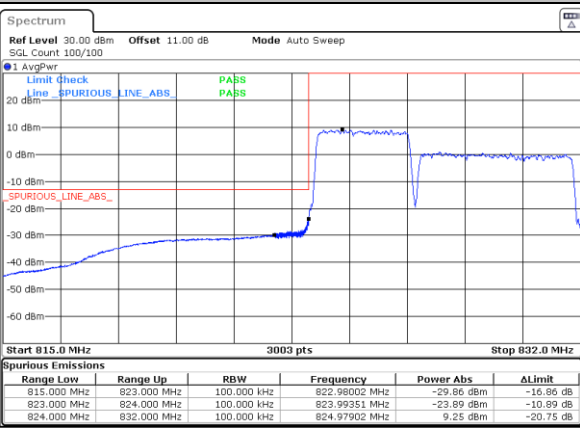

Date: 2.DEC.2022 02:13:59

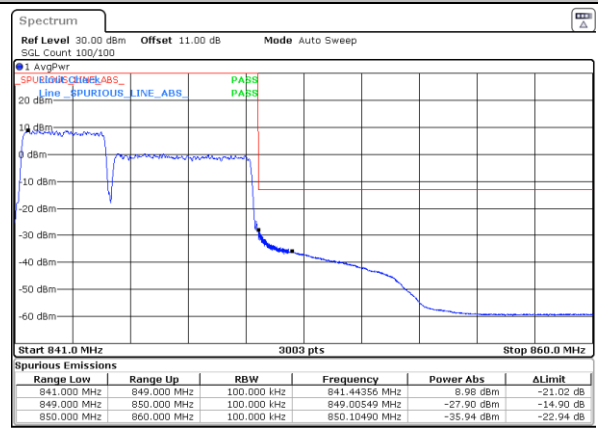

Date: 2.DEC.2022 01:41:49



LTE Band 5B / 5MHz+3MHz

16QAM

Lowest Band Edge / 1RB0 and 1RB14

Highest Band Edge / 1RB0 and 1RB14

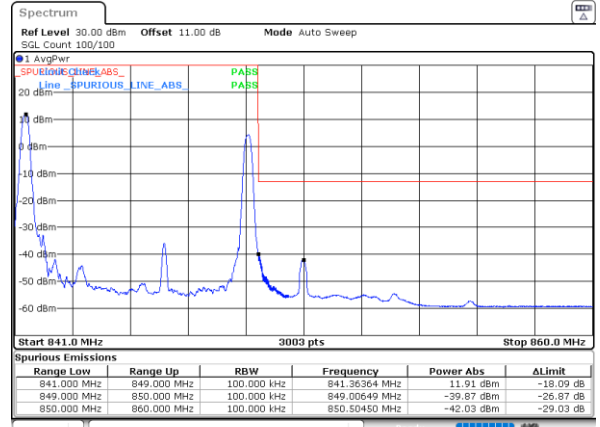
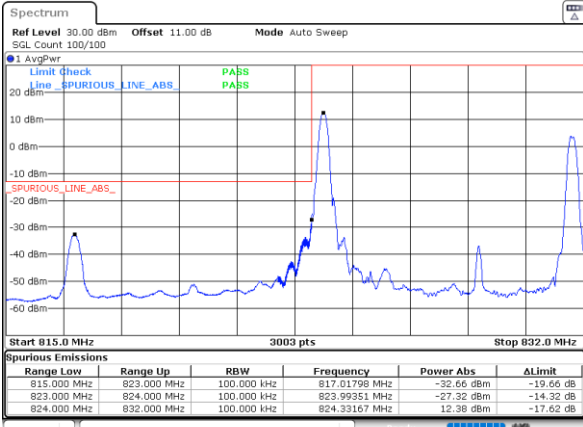

Date: 2, DEC, 2022 04:43:49

Date: 2, DEC, 2022 04:24:13

Lowest Band Edge / 1RB24 and 1RB0

Highest Band Edge / 1RB24 and 1RB0

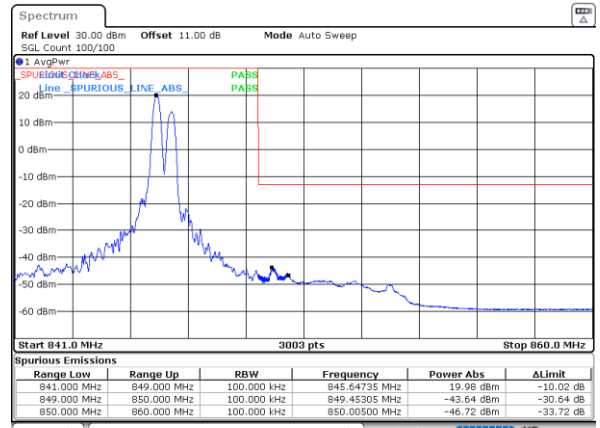
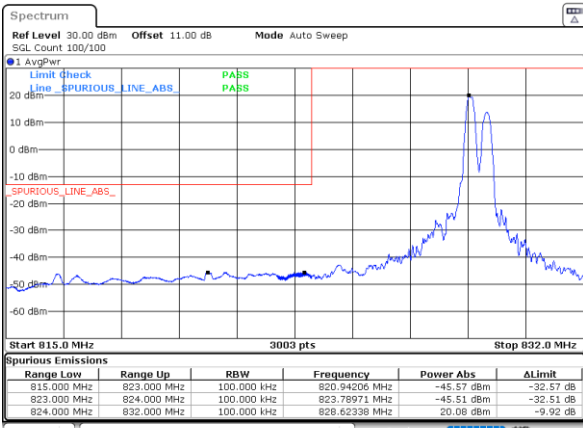

Date: 2, DEC, 2022 04:47:15

Date: 2, DEC, 2022 04:30:26

Lowest Band Edge / Full RB

Highest Band Edge / Full RB

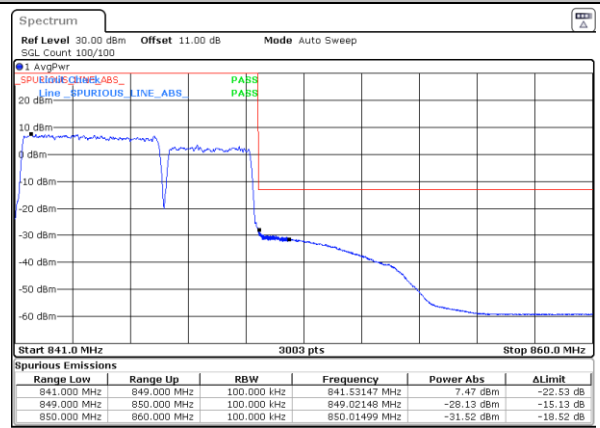
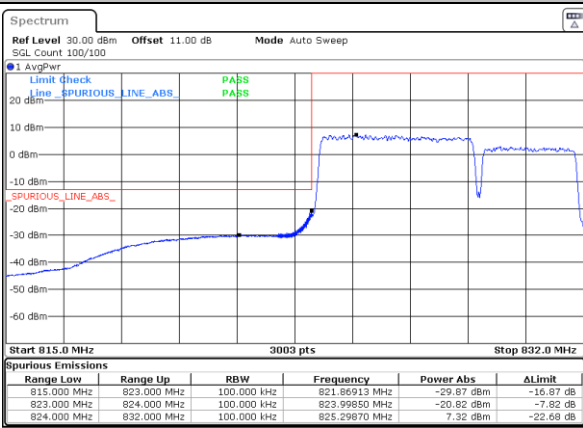

Date: 2, DEC, 2022 04:40:24

Date: 2, DEC, 2022 04:20:49



LTE Band 5B / 5MHz+10MHz

16QAM

Lowest Band Edge / 1RB0 and 1RB49

Highest Band Edge / 1RB0 and 1RB49

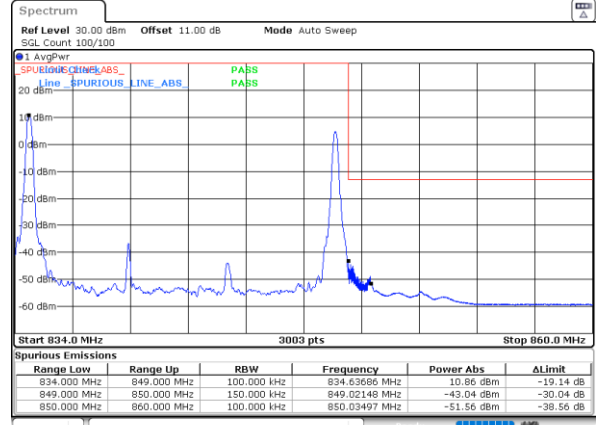
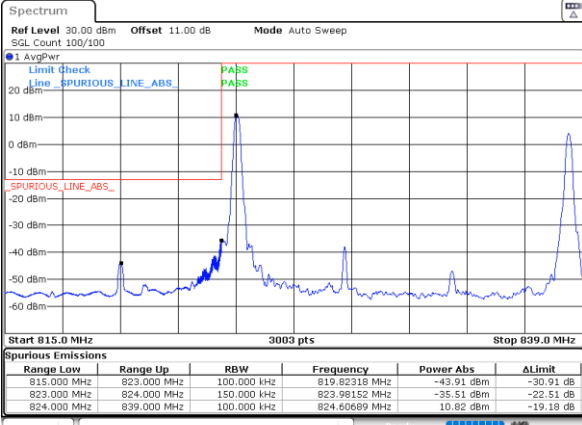

Date: 2, DEC, 2022 05:25:33

Date: 2, DEC, 2022 05:09:44

Lowest Band Edge / 1RB24 and 1RB0

Highest Band Edge / 1RB24 and 1RB0

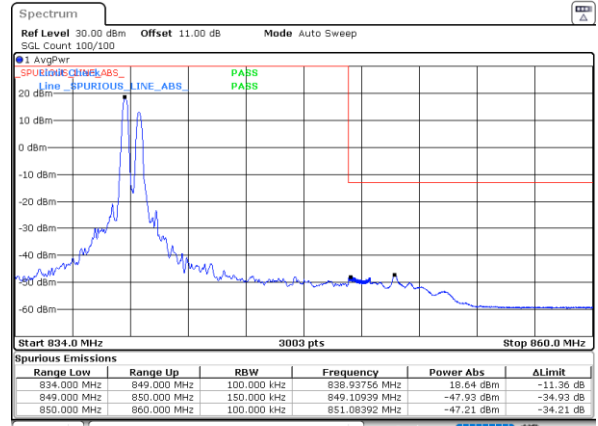
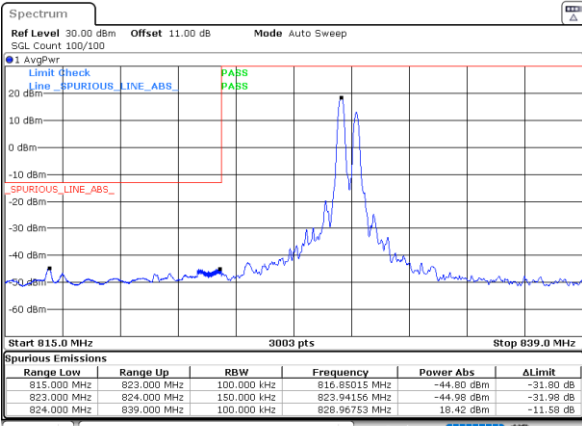

Date: 2, DEC, 2022 05:31:42

Date: 2, DEC, 2022 05:12:08

Lowest Band Edge / Full RB

Highest Band Edge / Full RB

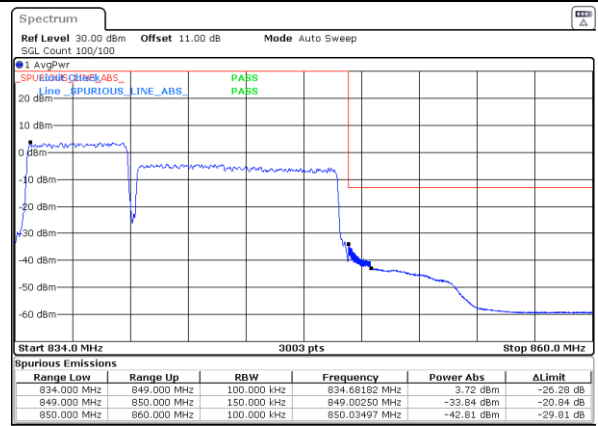
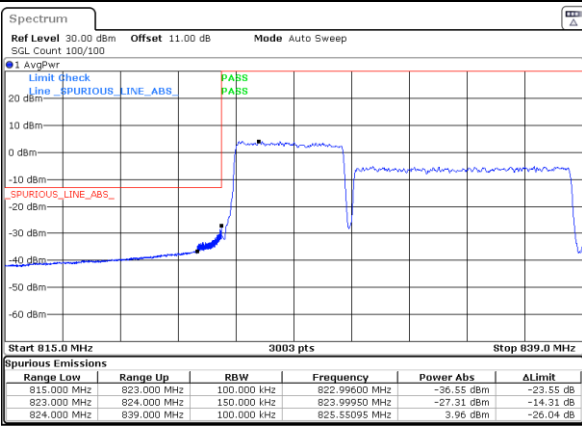

Date: 2, DEC, 2022 05:22:07

Date: 2, DEC, 2022 05:05:20