

Antenna Report

FCC ID: A4RG8V0U

November 9, 2022

Google LLC

1. Test Method

The antenna gains are obtained through measurements in a fully anechoic OTA chamber with a 3D positioner.

Measurements are taken in discrete steps in theta and phi direction, data is being recorded using the spectrum analyzer (active) or network analyzer (passive) for both theta and phi polarizations at each position resulting in a 3D gain pattern. Step size is <30 deg along both axes.

Gain is either derived directly through spatial averaging of VNA S21 measurements (passive measurement) or by the ratio of spatial averaging of 3D EIRP/TRP measurements vs the conducted power (active measurement).

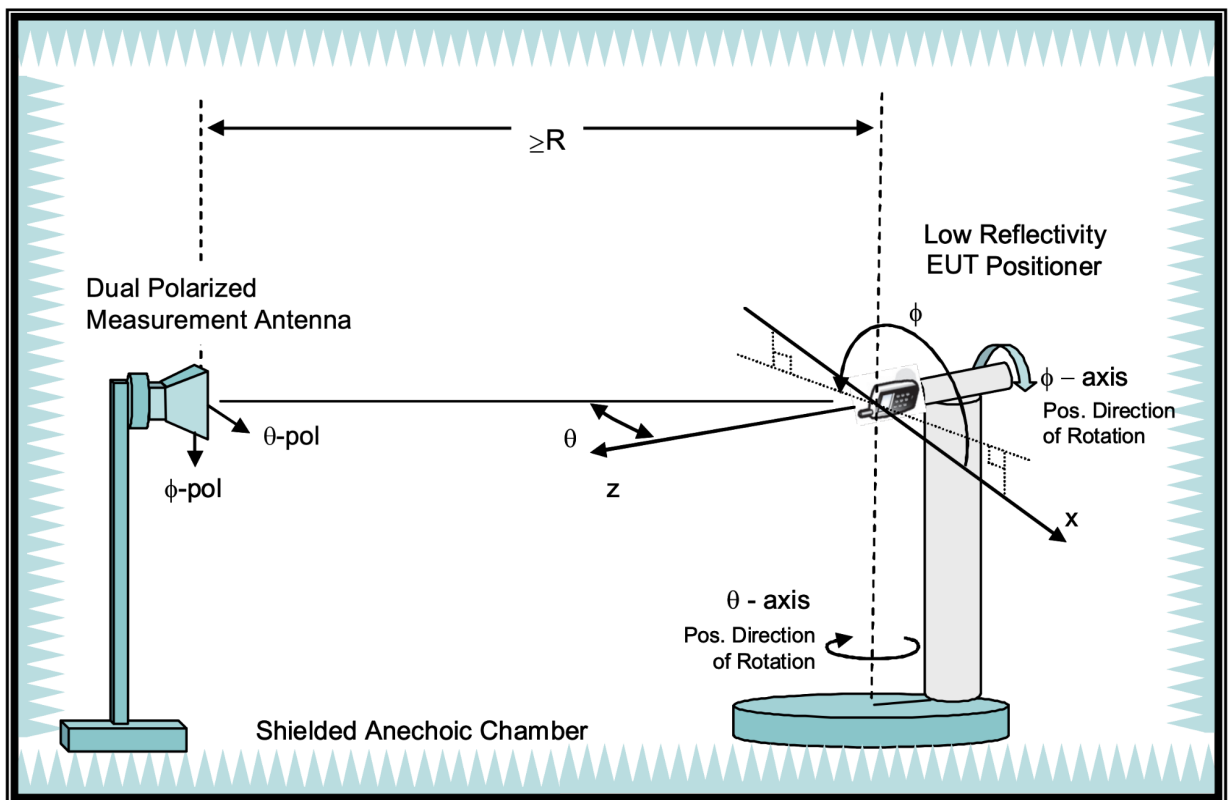

Measurements were obtained through an active non-signalling measurement (test mode) plus measured conductive RF power.

2. Test Equipment

Site Description	Chamber Manufacturer	Type
AMS-8923 Multi Probe Anechoic Chamber	ETS-Lindgren	Fully Anechoic
Software Version	ETS-Lindgren	EMQuest V1.15 Build 27342
Site location	1600 Amphitheatre Parkway Mountain View, CA 94043	
Test Engineer	Chulki Kwon	
Date	April 26, 2021	

Description	Manufacturer	Model	Calibration Date	Due Date
Network Analyzer	-	-	-	-
Spectrum Analyzer	Rohde & Schwarz	FSV7	Aug 1, 2019	Sep 21, 2023
Signaling Equipment	-	-	-	-

3. Test Setup

See separate appendix document for pictures of the test setup in this filing.

4. Antenna Type

Antenna Name	Antenna Type
Ant3	IFA
Ant4	IFA
Ant7	Slot

5. WLAN/BT Antennas

Antenna Gain Table:

Ant	Band	Frequency Band	Peak Gain(dBi)
Ant4	WiFi/BT 2.4 GHz	2402 MHz	-1.4
		2412 MHz	-1.1
		2437 MHz	-1.1
		2462 MHz	-1.7
		2480 MHz	-2.2
Ant3	WiFi/BT 2.4 GHz	2402 MHz	-2.5
		2412 MHz	-2.6
		2437 MHz	-2.4
		2462 MHz	-1.3
		2480 MHz	-0.6
Ant7	UNII-1	5180 MHz	-1.4
	UNII-2A	5280 MHz	-0.6
	UNII-2C	5500 MHz	-0.8
	UNII-3	5820 MHz	-1.5
	UNII-4	5887 MHz	-1.9
	UNII-5	6175 MHz	-2.4
	UNII-6	6475 MHz	-1.8
	UNII-7	6700 MHz	-0.4
	UNII-8	7000 MHz	-2.9
Ant3	UNII-1	5180 MHz	-1.7
	UNII-2A	5280 MHz	-2
	UNII-2C	5500 MHz	-2
	UNII-3	5820 MHz	-3.6
	UNII-4	5887 MHz	-2.1
	UNII-5	6175 MHz	-2
	UNII-6	6475 MHz	-1.5
	UNII-7	6700 MHz	-4
	UNII-8	7000 MHz	-3.7

Appendix: Radiation Plots

Ant4:

Ant4 Freq. 2412 MHz:

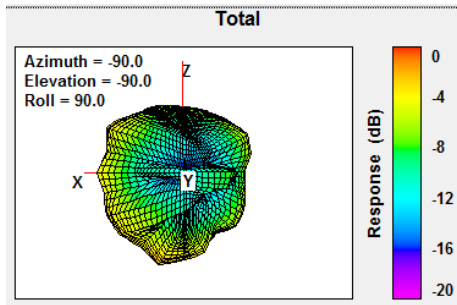

Ant4 Freq. 2462 MHz:

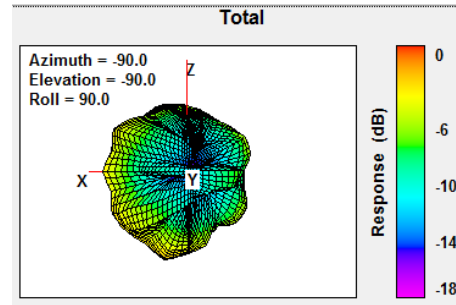

Ant4 Freq. 2437 MHz:

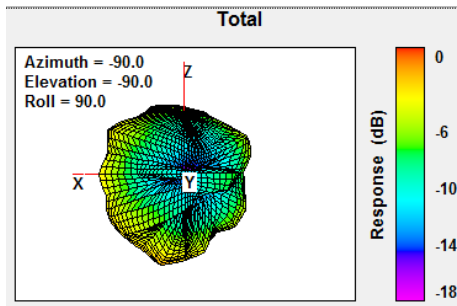

Ant3:

Ant3 Freq. 2412 MHz:

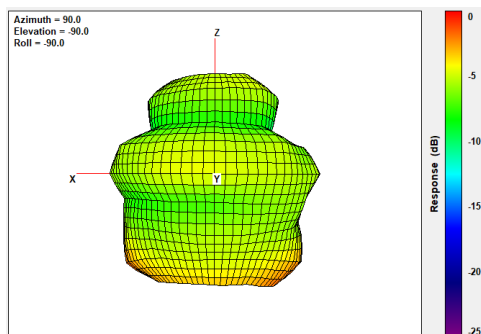

Ant3 Freq. 2437 MHz:

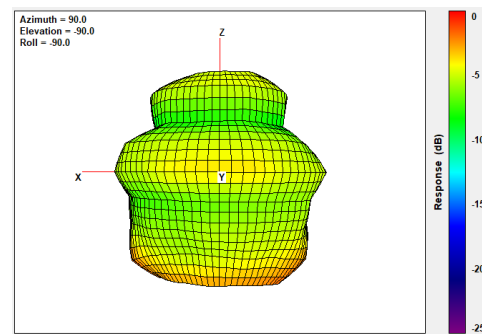

Ant3 Freq. 2462 MHz:

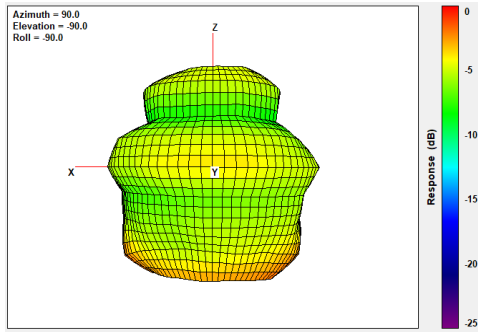

Ant3 Freq. 5965 MHz:

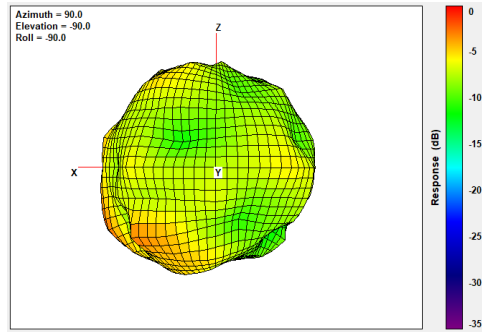

Ant3 Freq. 5180 MHz:

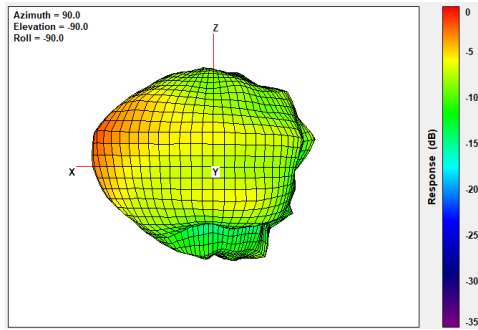

Ant3 Freq. 6525 MHz:

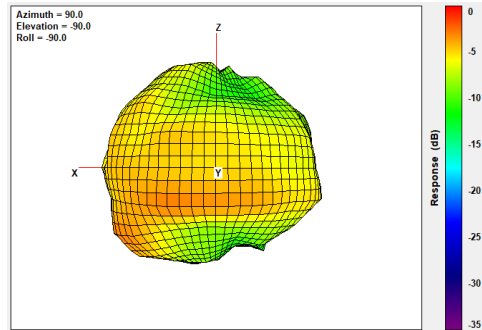

Ant3 Freq. 5500 MHz:

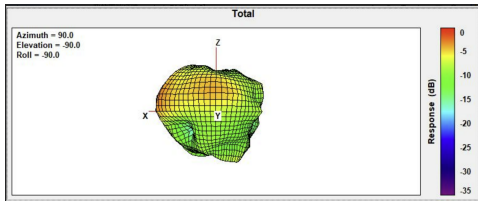

Ant3 Freq. 7085 MHz:

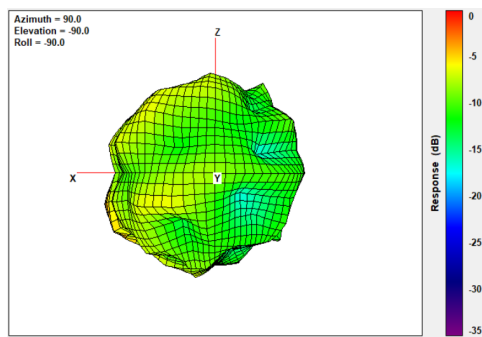

Ant3 Freq. 5805 MHz:

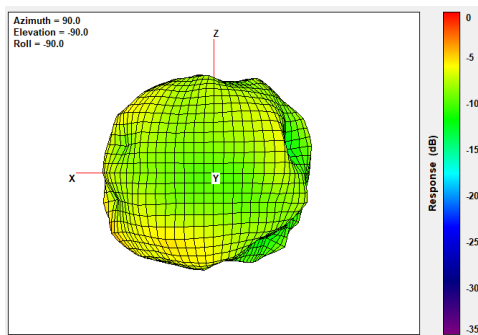

Ant7:

Ant7 Freq. 5180 MHz:

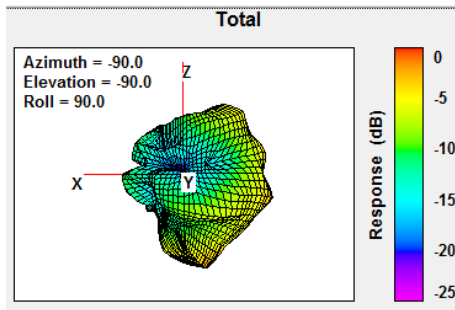

Ant7 Freq. 6525 MHz:

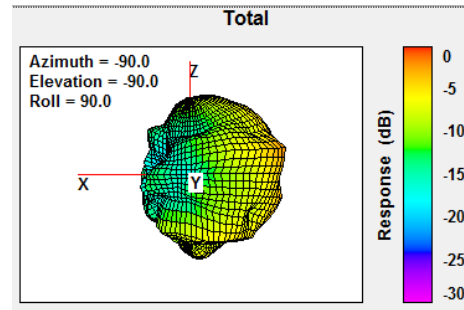

Ant7 Freq. 5500 MHz:

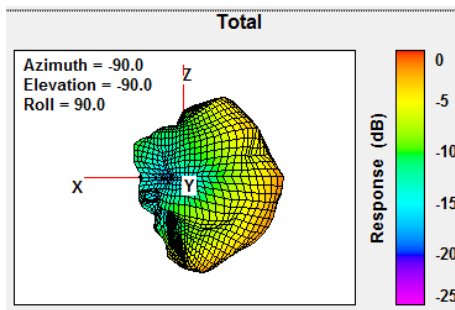

Ant7 Freq. 7085 MHz:

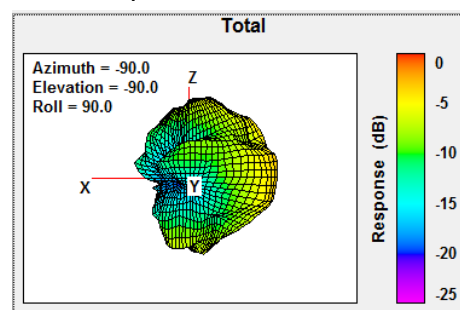

Ant7 Freq. 5805 MHz:

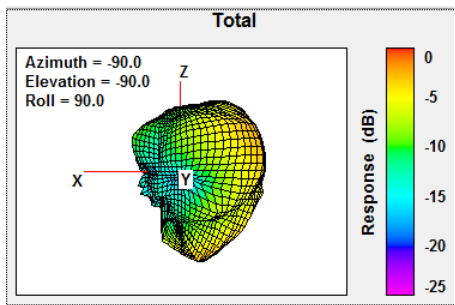

Ant7 Freq. 5965 MHz:

