



# FCC RADIO TEST REPORT

FCC ID : A4RG8V0U  
Equipment : Phone  
Model Name : G8V0U, GF5KQ  
Applicant : Google LLC  
1600 Amphitheatre Parkway,  
Mountain View, California, 94043 USA  
Standard : FCC Part 15 Subpart E §15.407

The product was received on Jun. 10, 2021 and testing was started from Jun.17, 2021 and completed on Aug. 24, 2021. We, Sporton International Inc. Wensan Laboratory, would like to declare that the tested sample has been evaluated in accordance with the test procedures and has been in compliance with the applicable technical standards.

The test results in this report apply exclusively to the tested model / sample. Without written approval of Sporton International Inc. Wensan Laboratory, the test report shall not be reproduced except in full.

Approved by: Louis Wu

**Sporton International Inc. Wensan Laboratory**

No.58, Aly. 75, Ln. 564, Wenhua 3rd, Rd., Guishan Dist., Taoyuan City 333010, Taiwan (R.O.C.)



## Table of Contents

History of this test report.....	3
Summary of Test Result.....	4
<b>1 General Description .....</b>	<b>5</b>
1.1 Product Feature of Equipment Under Test.....	5
1.2 Product Specification of Equipment Under Test.....	6
1.3 Modification of EUT .....	6
1.4 Testing Location .....	7
1.5 Applicable Standards.....	7
<b>2 Test Configuration of Equipment Under Test .....</b>	<b>8</b>
2.1 Carrier Frequency and Channel .....	8
2.2 Test Mode.....	9
2.3 Connection Diagram of Test System.....	10
2.4 Support Unit used in test configuration and system .....	11
2.5 EUT Operation Test Setup .....	11
2.6 Measurement Results Explanation Example.....	11
<b>3 Test Result .....</b>	<b>12</b>
3.1 6dB and 26dB and 99% Occupied Bandwidth Measurement .....	12
3.2 Maximum Conducted Output Power Measurement .....	16
3.3 Power Spectral Density Measurement .....	17
3.4 Unwanted Emissions Measurement.....	21
3.5 AC Conducted Emission Measurement.....	25
3.6 Antenna Requirements .....	27
<b>4 List of Measuring Equipment.....</b>	<b>29</b>
<b>5 Uncertainty of Evaluation .....</b>	<b>31</b>
<b>Appendix A. Conducted Test Results</b>	
<b>Appendix B. AC Conducted Emission Test Result</b>	
<b>Appendix C. Radiated Spurious Emission</b>	
<b>Appendix D. Radiated Spurious Emission Plots</b>	
<b>Appendix E. Duty Cycle Plots</b>	



### History of this test report

Report No.	Version	Description	Issued Date
FR121931-04F	01	Initial issue of report	Aug. 13, 2021
FR121931-04F	02	1. Retest for 26dB and 99% bandwidth 2. Revise remark for antenna gain calculation	Aug. 25, 2021



## Summary of Test Result

Report Clause	Ref Std. Clause	Test Items	Result (PASS/FAIL)	Remark
3.1	15.403(i)	6dB & 26dB Bandwidth	Pass	-
3.1	2.1049	99% Occupied Bandwidth	Reporting only	-
3.2	15.407(a)	Maximum Conducted Output Power	Pass	-
3.3	15.407(a)	Power Spectral Density	Pass	-
3.4	15.407(b)	Unwanted Emissions	Pass	Under limit 3.25 dB at 17355.000 MHz
3.5	15.207	AC Conducted Emission	Pass	Under limit 6.05 dB at 0.191 MHz
3.6	15.203 15.407(a)	Antenna Requirement	Pass	-

**Declaration of Conformity:**

The test results with all measurement uncertainty excluded are presented in accordance with the regulation limits or requirements declared by manufacturers.

**Comments and Explanations:**

The declared of product specification for EUT presented in the report are provided by the manufacturer, and the manufacturer takes all the responsibilities for the accuracy of product specification.

**Reviewed by: William Chen**

**Report Producer: Vivian Hsu**



# 1 General Description

## 1.1 Product Feature of Equipment Under Test

Product Feature	
Equipment	Phone
Model Name	G8V0U, GF5KQ
FCC ID	A4RG8V0U
EUT supports Radios application	GSM/EGPRS/WCDMA/HSPA/LTE/5G NR/ NFC/GNSS/WPC/WPT/UWB WLAN 11b/g/n HT20 WLAN 11a/n HT20/HT40 WLAN 11ac VHT20/VHT40/VHT80/VHT160 WLAN 11ax HE20/HE40/HE80/HE160 Bluetooth BR/EDR/LE

Remark: The above EUT's information was declared by manufacturer.

EUT Information List	
S/N	Performed Test Item
15281FDEE0002D	RF Conducted Measurement
16061FDEE0000Q	Radiated Spurious Emission
16061FDEE00001	Conducted Emission



## 1.2 Product Specification of Equipment Under Test

Standards-related Product Specification							
<b>Tx/Rx Channel Frequency Range</b>	5745 MHz ~ 5825 MHz						
<b>Maximum Output Power</b>	<b>MIMO &lt;Ant. 7 + 3&gt;</b> 802.11a: 21.40 dBm / 0.1380 W 802.11n HT20: 22.14 dBm / 0.1637 W 802.11n HT40: 22.44 dBm / 0.1754 W 802.11ac VHT20: 22.13 dBm / 0.1633 W 802.11ac VHT40: 22.54 dBm / 0.1795 W 802.11ac VHT80: 22.89 dBm / 0.1945 W 802.11ax HE20: 22.34 dBm / 0.1714 W 802.11ax HE40: 22.64 dBm / 0.1837 W 802.11ax HE80: 22.99 dBm / 0.1991 W						
<b>99% Occupied Bandwidth</b>	<b>MIMO &lt;Ant. 7&gt;</b> 802.11a: 17.23 MHz 802.11ax HE20: 19.38 MHz 802.11ac HE40: 38.26 MHz 802.11ac HE80: 77.32 MHz <b>MIMO &lt;Ant. 3&gt;</b> 802.11a: 17.38 MHz 802.11ax HE20: 19.58 MHz 802.11ac HE40: 38.56 MHz 802.11ac HE80: 77.56 MHz						
<b>Type of Modulation</b>	802.11a/n : OFDM (BPSK / QPSK / 16QAM / 64QAM) 802.11ac : OFDM (BPSK / QPSK / 16QAM / 64QAM / 256QAM) 802.11ax: OFDMA (BPSK/QPSK/16QAM/64QAM/256QAM/1024QAM)						
<b>Antenna Type / Gain</b>	<b>&lt;Ant. 7&gt;</b> : Slot Antenna with gain -1.50 dBi <b>&lt;Ant. 3&gt;</b> : IFA Antenna with gain -3.60 dBi						
<b>Antenna Function Description</b>	<table border="1"> <thead> <tr> <th></th> <th>Ant. 7</th> <th>Ant. 3</th> </tr> </thead> <tbody> <tr> <td>802.11 a/n/ac/ax MIMO</td> <td>V</td> <td>V</td> </tr> </tbody> </table>		Ant. 7	Ant. 3	802.11 a/n/ac/ax MIMO	V	V
	Ant. 7	Ant. 3					
802.11 a/n/ac/ax MIMO	V	V					

**Remark:**

- MIMO Ant. 7+3 Directional Gain is a calculated result from MIMO Ant. 7 and MIMO Ant. 3. The formula used in calculation is documented in section 3.6.  
Power of MIMO Ant. 7 + Ant. 3 is a calculated result from sum of the power MIMO Ant. 7 and MIMO Ant. 3.
- The above EUT's information was declared by manufacturer. Please refer to Comments and Explanations in report summary.

## 1.3 Modification of EUT

No modifications are made to the EUT during all test items.



### 1.4 Testing Location

<b>Test Site</b>	Sporton International Inc. EMC & Wireless Communications Laboratory
<b>Test Site Location</b>	No.52, Huaya 1st Rd., Guishan Dist., Taoyuan City 333, Taiwan (R.O.C.) TEL: +886-3-327-3456 FAX: +886-3-328-4978
<b>Test Site No.</b>	<b>Sporton Site No.</b> CO05-HY (TAF Code: 1190)
<b>Remark</b>	The Conducted Emission test item subcontracted to Sporton International Inc. EMC & Wireless Communications Laboratory.

**Note:** The test site complies with ANSI C63.4 2014 requirement.

<b>Test Site</b>	Sporton International Inc. Wensan Laboratory
<b>Test Site Location</b>	No.58, Aly. 75, Ln. 564, Wenhua 3rd, Rd., Guishan Dist., Taoyuan City 333010, Taiwan (R.O.C.) TEL: +886-3-327-0868 FAX: +886-3-327-0855
<b>Test Site No.</b>	<b>Sporton Site No.</b> TH05-HY, 03CH13-HY

**Note:** The test site complies with ANSI C63.4 2014 requirement.

FCC designation No.: TW1190 and TW3786

### 1.5 Applicable Standards

According to the specifications of the manufacturer, the EUT must comply with the requirements of the following standards:

- ♦ FCC Part 15 Subpart E
- ♦ FCC KDB 789033 D02 General UNII Test Procedures New Rules v02r01.
- ♦ FCC KDB 414788 D01 Radiated Test Site v01r01.
- ♦ FCC KDB 662911 D01 Multiple Transmitter Output v02r01.
- ♦ ANSI C63.10-2013

**Remark:**

1. All test items were verified and recorded according to the standards and without any deviation during the test.
2. The TAF code is not including all the FCC KDB listed without accreditation.



## 2 Test Configuration of Equipment Under Test

- a. The EUT has been associated with peripherals and configuration operated in a manner tended to maximize its emission characteristics in a typical application. Frequency range investigated: conduction emission (150 kHz to 30 MHz), radiation emission (9 kHz to the 10th harmonic of the highest fundamental frequency or to 40 GHz, whichever is lower). The measured emission level of the EUT was maximized by rotating the EUT on a turntable, adjusting the orientation of the EUT and EUT antenna in three orthogonal axis (X: flat, Y: portrait, Z: landscape), and adjusting the measurement antenna orientation, following C63.10 exploratory test procedures and find Y plane with Adapter as worst plane.
- b. AC power line Conducted Emission was tested under maximum output power.

### 2.1 Carrier Frequency and Channel

Frequency Band	Channel	Freq. (MHz)	Channel	Freq. (MHz)
5725-5850 MHz Band 4 (U-NII-3)	149	5745	157	5785
	151*	5755	159*	5795
	153	5765	161	5805
	155#	5775	165	5825

**Note:**

1. The above Frequency and Channel in "\*" were 802.11n HT40 and 802.11ac VHT40 and 802.11ax HE40.
2. The above Frequency and Channel in "#n" were 802.11ac VHT80 and 802.11ax HE80.





## 2.2 Test Mode

This device support 26/52/106/242/484/996-tone RU but does not support 2x996-tone RU on 160MHz channel.

The PSD of partial RU is reduced to be smaller than full RU according to TCB workshop interim guidance.

Final test modes are considering the modulation and worse data rates as below table.

Modulation	Data Rate
802.11a	6 Mbps
802.11n HT20 (Covered by HE20)	MCS0
802.11n HT40 (Covered by HE40)	MCS0
802.11ac VHT20 (Covered by HE20)	MCS0
802.11ac VHT40 (Covered by HE40)	MCS0
802.11ac VHT80 (Covered by HE80)	MCS0
802.11ax HE20	MCS0
802.11ax HE40	MCS0
802.11ax HE80	MCS0

Test Cases	
<b>AC Conducted Emission</b>	Mode 1: WLAN (5GHz) Link + Bluetooth Link + USB Cable 1 (Charging from AC Adapter 2)
<b>Remark:</b>	
<ol style="list-style-type: none"> <li>For Radiated Test Cases, the tests were performed with Adapter 2 and USB Cable 1.</li> <li>During the preliminary test, both charging modes (Adapter mode and WPC Charging mode) were verified. It is determined that the adaptor mode is the worst case for official test.</li> </ol>	

Ch. #	Band IV : 5725-5850 MHz			
	802.11a	802.11ax HE20	802.11ax HE40	802.11ax HE80
L Low	149	149	151	-
M Middle	157	157	-	155
H High	165	165	159	-

Remark: For radiation spurious emission, the final modulation and the worst data rate was reference the max RF conducted power.

## 2.3 Connection Diagram of Test System

<AC Conducted Emission Mode>

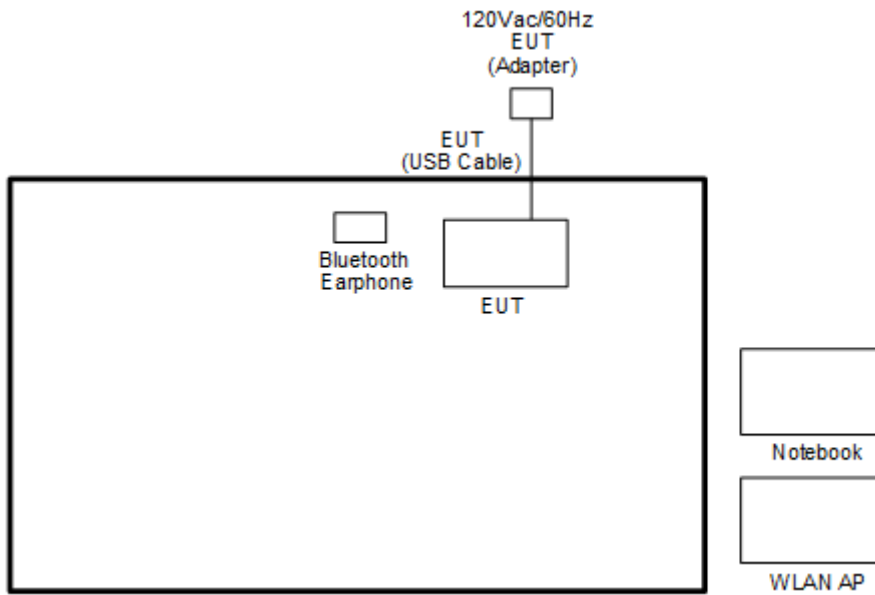

<WLAN Tx Mode>

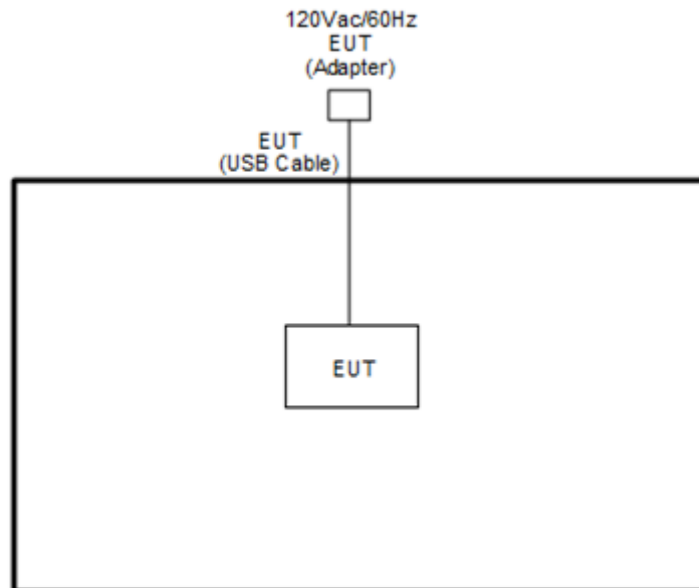



## 2.4 Support Unit used in test configuration and system

Item	Equipment	Brand Name	Model Name	FCC ID	Data Cable	Power Cord
1.	Bluetooth Earphone	Google	G1007, G1008	A4RG1008 A4RG1007	N/A	N/A
2.	WLAN AP	ASUS	RT-AC66U	MSQ-RTAC66U	N/A	Unshielded, 1.8 m
3.	Notebook	Dell	Latitude 3400	FCC DoC	N/A	AC I/P : Unshielded, 1.2m DC O/P : Shielded, 1.8m

## 2.5 EUT Operation Test Setup

The RF test items, utility “adb command V\_1.0.36” was installed in Notebook which was programmed in order to make the EUT get into the engineering modes to provide channel selection, power level, data rate and the application type and for continuous transmitting signals.

## 2.6 Measurement Results Explanation Example

For all conducted test items:

The offset level is set in the spectrum analyzer to compensate the RF cable loss and attenuator factor between EUT conducted output port and spectrum analyzer. With the offset compensation, the spectrum analyzer reading level is exactly the EUT RF output level.

Example :

The spectrum analyzer offset is derived from RF cable loss and attenuator factor.

*Offset = RF cable loss + attenuator factor.*

Following shows an offset computation example with cable loss 4.2 dB and 10 dB attenuator.

$$\begin{aligned} \text{Offset(dB)} &= \text{RF cable loss(dB)} + \text{attenuator factor(dB)}. \\ &= 4.2 + 10 = 14.2 \text{ (dB)} \end{aligned}$$

### 3 Test Result

#### 3.1 6dB and 26dB and 99% Occupied Bandwidth Measurement

##### 3.1.1 Description of 6dB and 26dB and 99% Occupied Bandwidth

The minimum 6 dB bandwidth shall be at least 500 kHz.

26dB and 99% Occupied bandwidth are reporting only.

##### 3.1.2 Measuring Instruments

See list of measuring equipment of this test report.

##### 3.1.3 Test Procedures

1. The testing follows FCC KDB 789033 D02 General UNII Test Procedures New Rules v02r01. Section C) Emission bandwidth for the band 5.725-5.85 GHz
2. Set RBW = 100 kHz.
3. Set the VBW  $\geq 3 \times$  RBW.
4. Detector = Peak.
5. Trace mode = max hold
6. Measure the maximum width of the emission that is 6 dB down from the peak of the emission.
7. Measure and record the results in the test report.

##### 3.1.4 Test Setup

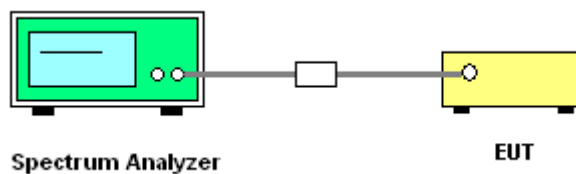

##### 3.1.5 Test Result of 6dB and 26dB and 99% Occupied Bandwidth

Please refer to Appendix A.

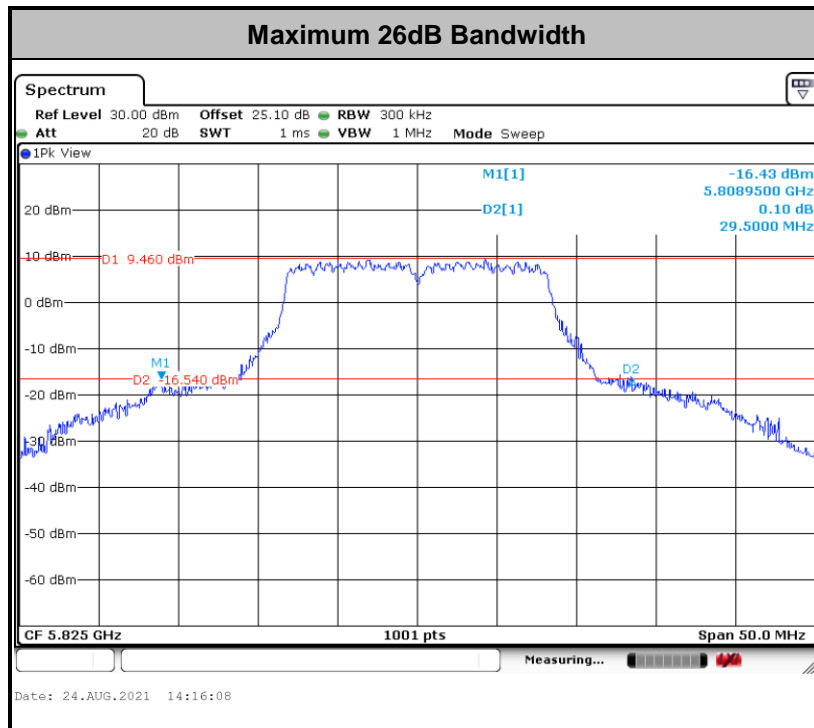
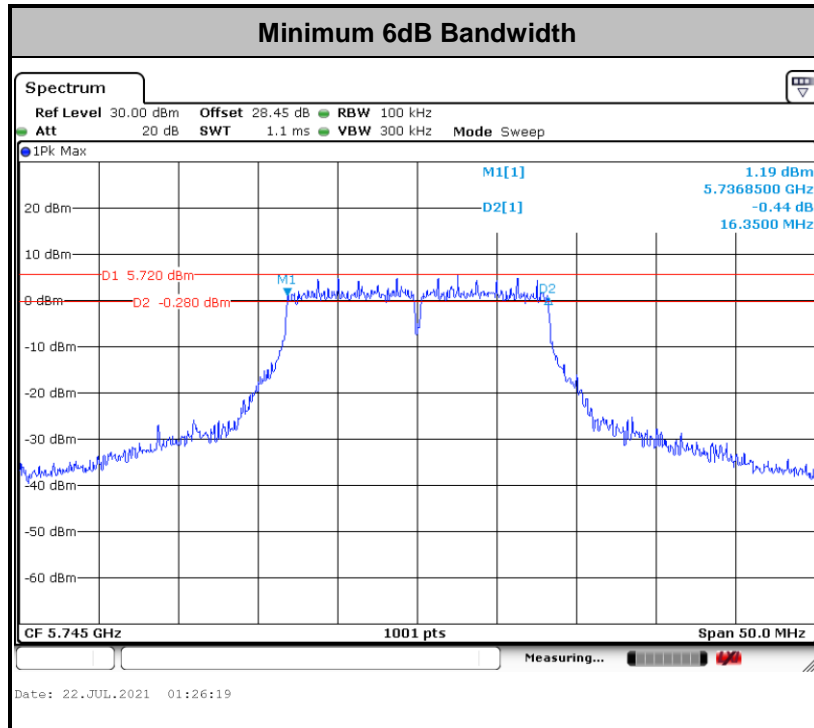

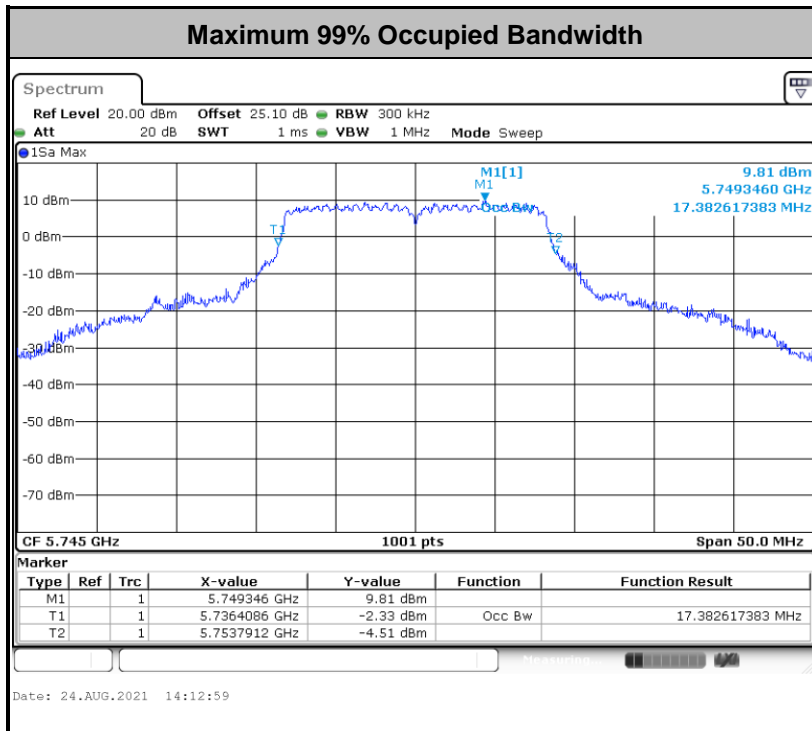

**Note:** The occupied channel bandwidth is maintained within the band of operation for all of the modulations.

<For 802.11ax Mode>

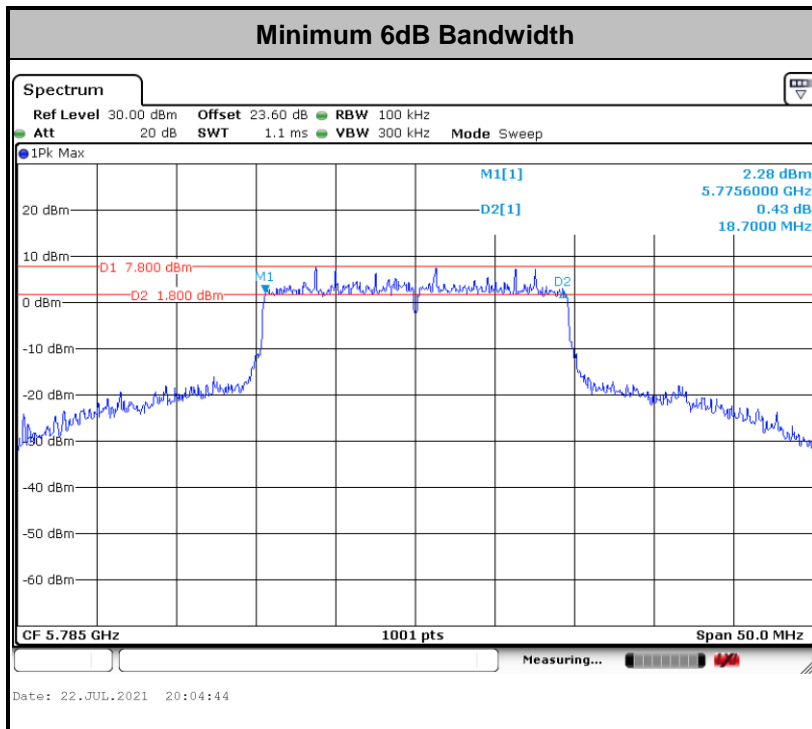

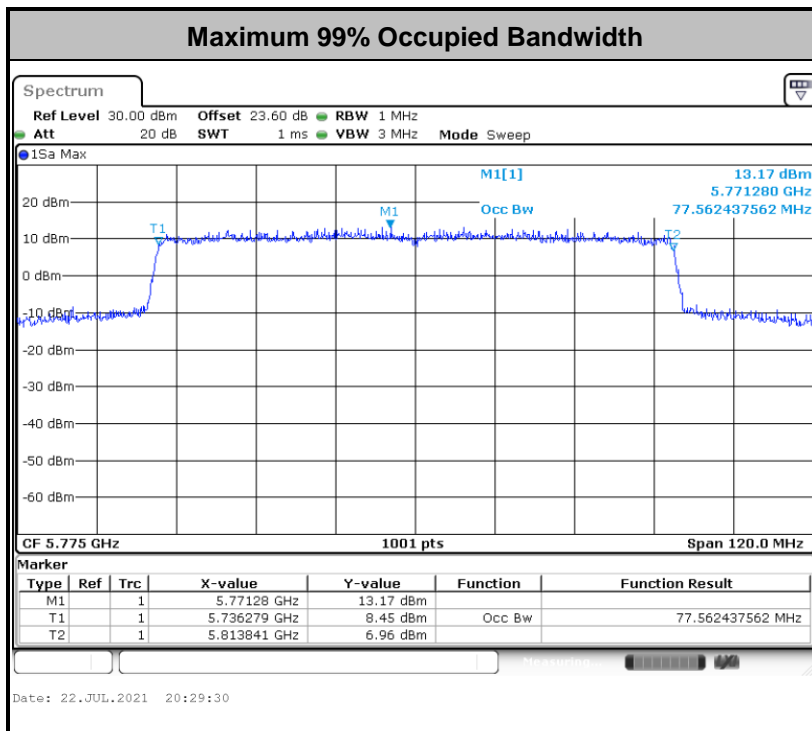
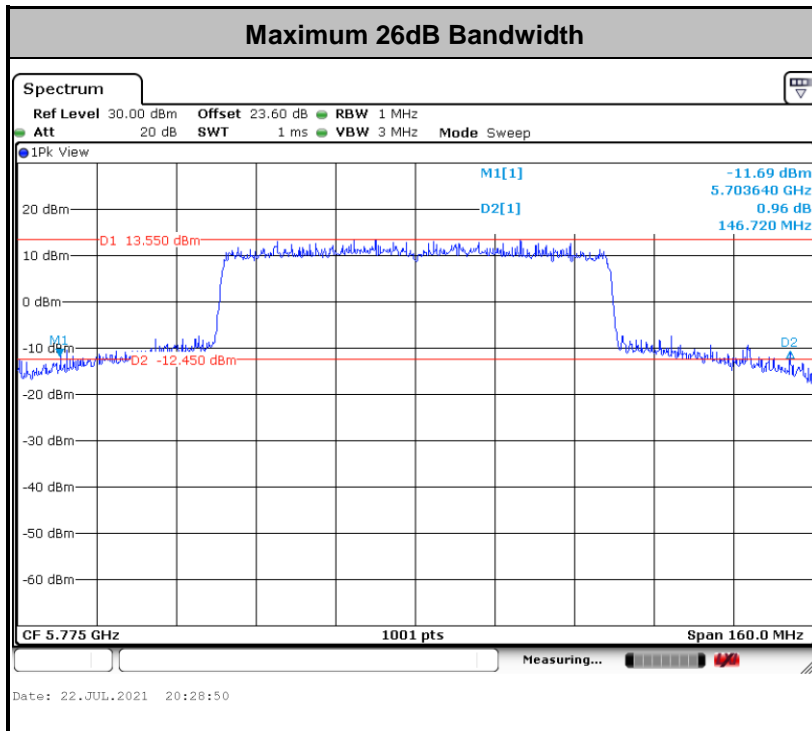

**Note:** The occupied channel bandwidth is maintained within the band of operation for all of the modulations.

## 3.2 Maximum Conducted Output Power Measurement

### 3.2.1 Limit of Maximum Conducted Output Power

For the band 5.725–5.85 GHz, the maximum conducted output power over the frequency band of operation shall not exceed 1 W.

If transmitting antennas of directional gain greater than 6 dBi are used, the peak output power shall be reduced by the amount in dB that the directional gain of the antenna exceeds 6 dBi.

### 3.2.2 Measuring Instruments

See list of measuring equipment of this test report.

### 3.2.3 Test Procedures

The testing follows Method PM-G of FCC KDB 789033 D02 General UNII Test Procedures New Rules v02r01.

Method PM-G (Measurement using a gated RF average power meter):

1. Measurement is performed using a wideband RF power meter.
2. The EUT is configured to transmit at its maximum power control level.
3. Measure the average power of the transmitter.
4. Since the measurement is made only during the ON time of the transmitter, no duty cycle correction factor is required.

### 3.2.4 Test Setup

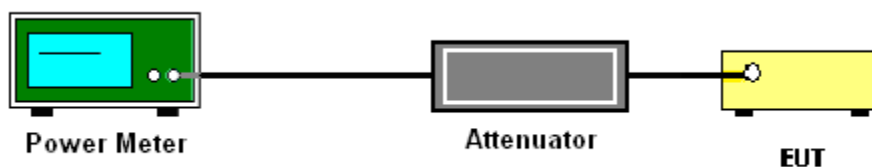

### 3.2.5 Test Result of Maximum Conducted Output Power

Please refer to Appendix A.





### 3.3 Power Spectral Density Measurement

#### 3.3.1 Limit of Power Spectral Density

For the band 5.725–5.85 GHz, the maximum power spectral density shall not exceed 30 dBm in any 500-kHz band.

If transmitting antennas of directional gain greater than 6 dBi are used, the peak output power shall be reduced by the amount in dB that the directional gain of the antenna exceeds 6 dBi.

#### 3.3.2 Measuring Instruments

See list of measuring equipment of this test report.

#### 3.3.3 Test Procedures

The testing follows FCC KDB 789033 D02 General UNII Test Procedures New Rules v02r01. Section F) Maximum power spectral density.

##### # Method SA-3 #

(power averaging (rms) detection with max hold):

- Set span to encompass the entire emission bandwidth (EBW) of the signal.
  - Set RBW = 1 MHz.
  - Set VBW  $\geq$  3 MHz.
  - Number of points in sweep  $\geq$  2 Span / RBW.
  - Sweep time  $\leq$  (number of points in sweep)  $\times$  T, when duty cycle is less than 98 percent where T is the minimum transmission duration over which the transmitter is on and is transmitting at its maximum power control level for the tested mode of operation.  
Detector = power averaging (rms).
  - Trace mode = max hold.
  - Allow max hold to run for at least 60 seconds, or longer as needed to allow the trace to stabilize.
1. The RF output of EUT was connected to the spectrum analyzer by a low loss cable.
  2. Each plot has already offset with cable loss, and attenuator loss. Measure the PPSD and record it.
  3. For MIMO mode, calculation method follows FCC KDB 662911 D01 Multiple Transmitter Output v02r01.  
Method (c): Measure and add  $10 \log(N_{ANT})$  dB.  
With this technique, spectrum measurements are performed at each output of the device, but rather than summing the spectra or the spectral peaks across the outputs, the quantity  $10 \log(N_{ANT})$  dB is added to each spectrum value before comparing to the emission limit. The addition of  $10 \log(N_{ANT})$  dB serves to apportion the emission limit among the  $N_{ANT}$  outputs so that each output is permitted to contribute no more than  $1/N_{ANT}^{th}$  of the PSD limit.

### 3.3.4 Test Setup

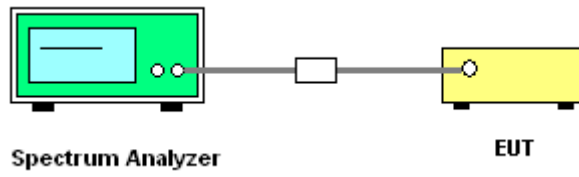



### 3.3.5 Test Result of Power Spectral Density

Please refer to Appendix A.

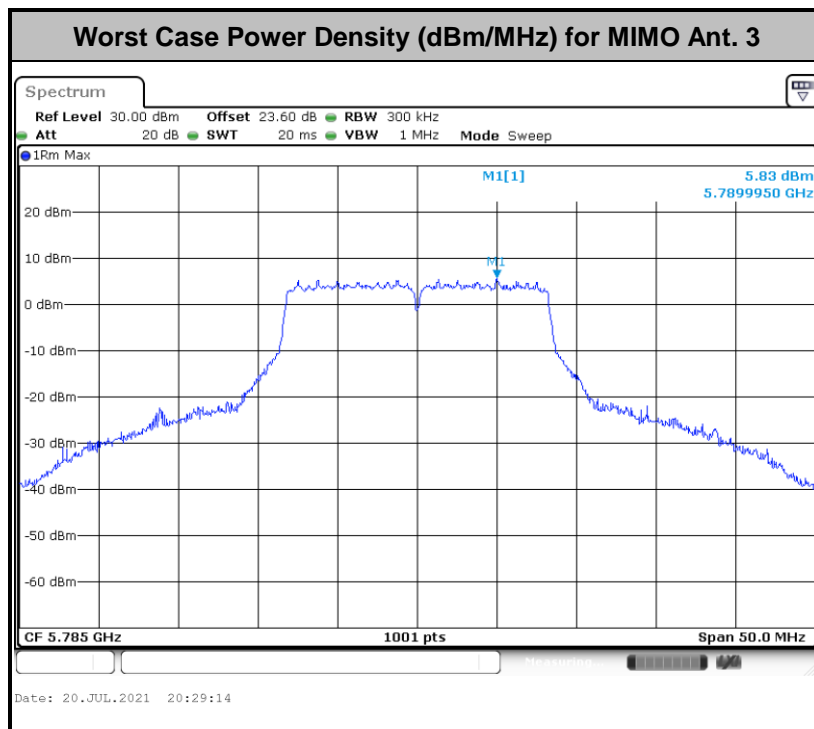
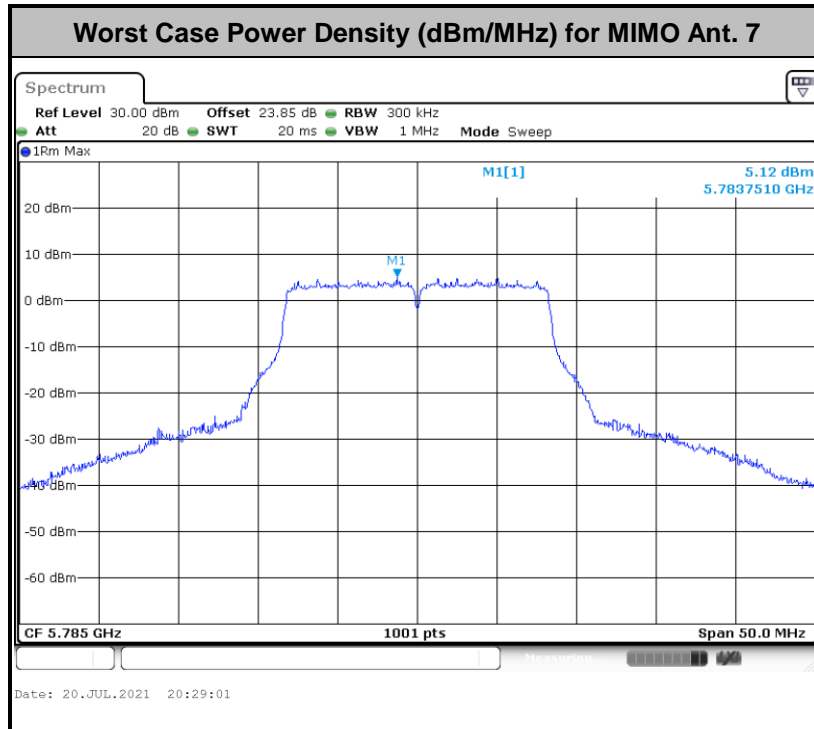



<For 802.11ax Mode>

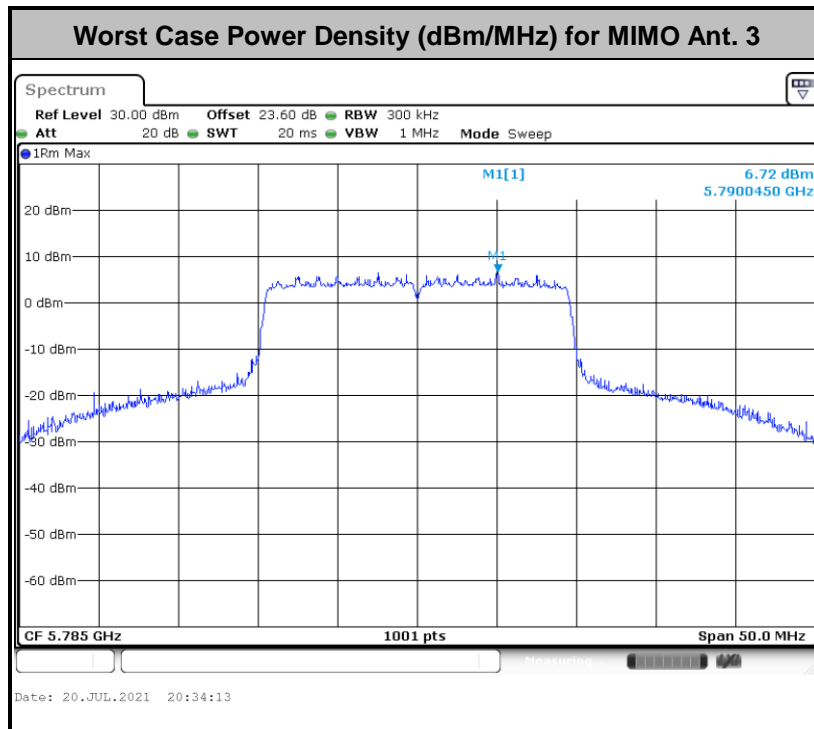
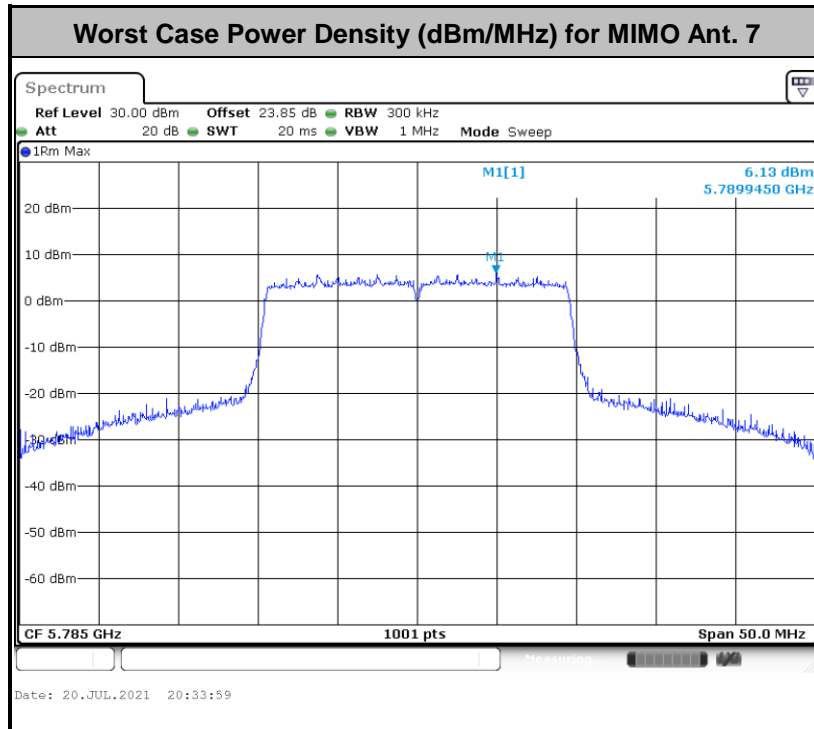



### 3.4 Unwanted Emissions Measurement

This section is to measure unwanted emissions through radiated measurement for band edge spurious emissions and out of band emissions measurement.

#### 3.4.1 Limit of Unwanted Emissions

(1) For transmitters operating in the 5.725-5.85 GHz band:

15.407(b)(4)(i) All emissions shall be limited to a level of -27 dBm/MHz at 75 MHz or more above or below the band edge increasing linearly to 10 dBm/MHz at 25 MHz above or below the band edge, and from 25 MHz above or below the band edge increasing linearly to a level of 15.6 dBm/MHz at 5 MHz above or below the band edge, and from 5 MHz above or below the band edge increasing linearly to a level of 27 dBm/MHz at the band edge.

(2) Unwanted spurious emissions fallen in restricted bands shall comply with the general field strength limits as below table,

Frequency (MHz)	Field Strength (microvolts/meter)	Measurement Distance (meters)
0.009 – 0.490	2400/F(kHz)	300
0.490 – 1.705	24000/F(kHz)	30
1.705 – 30.0	30	30
30 – 88	100	3
88 – 216	150	3
216 - 960	200	3
Above 960	500	3

**Note:** The following formula is used to convert the EIRP to field strength.

$$E = \frac{1000000\sqrt{30P}}{3} \text{ } \mu\text{V/m, where P is the eirp (Watts)}$$

EIRP (dBm)	Field Strength at 3m (dBμV/m)
- 27	68.3

(3) KDB789033 D02 v02r01 G)2)c)

(i) Sections 15.407(b)(1-3) specifies the unwanted emissions limit for the U-NII-1 and U-NII-2 bands. As specified, emissions above 1000 MHz that are outside of the restricted bands are subject to a peak emission limit of -27 dBm/MHz.

(ii) Section 15.407(b)(4) specifies the unwanted emissions limit for the U-NII-3 band. A band emissions mask is specified in Section 15.407(b)(4)(i). The emission limits are based on the use of a peak detector.

#### 3.4.2 Measuring Instruments

See list of measuring equipment of this test report.



### 3.4.3 Test Procedures

1. The testing follows FCC KDB 789033 D02 General UNII Test Procedures New Rules v02r01. Section G) Unwanted emissions measurement.
  - (1) Procedure for Unwanted Emissions Measurements Below 1000 MHz
    - RBW = 120 kHz
    - VBW = 300 kHz
    - Detector = Peak
    - Trace mode = max hold
  - (2) Procedure for Peak Unwanted Emissions Measurements Above 1000 MHz
    - RBW = 1 MHz
    - VBW  $\geq$  3 MHz
    - Detector = Peak
    - Sweep time = auto
    - Trace mode = max hold
  - (3) Procedures for Average Unwanted Emissions Measurements Above 1000 MHz
    - RBW = 1 MHz
    - VBW = 10 Hz, when duty cycle is no less than 98 percent.
    - VBW  $\geq$  1/T, when duty cycle is less than 98 percent where T is the minimum transmission duration over which the transmitter is on and is transmitting at its maximum power control level for the tested mode of operation.
2. The EUT was placed on a turntable with 0.8 meter for frequency below 1 GHz and 1.5 meter for frequency above 1 GHz respectively above ground.
3. The EUT was set 3 meters from the interference receiving antenna which was mounted on the top of a variable height antenna tower.
4. The antenna is a broadband antenna and its height is adjusted between one meter and four meters above ground to find the maximum value of the field strength for both horizontal polarization and vertical polarization of the antenna.
5. For each suspected emission, the EUT was arranged to its worst case and then adjust the antenna tower (from 1 m to 4 m) and turntable (from 0 degree to 360 degrees) to find the maximum reading.
6. For testing below 1 GHz, if the emission level of the EUT in peak mode was 3 dB lower than the limit specified, then peak values of EUT will be reported, otherwise, the emissions will be repeated one by one using the CISPR quasi-peak method and reported.
7. For testing above 1 GHz, the emission level of the EUT in peak mode was 20 dB lower than average limit (that means the emission level in average mode also complies with the limit in average mode), then peak values of EUT will be reported, otherwise, the emissions will be measured in average mode again and reported.

### 3.4.4 Test Setup

For radiated emissions below 30MHz

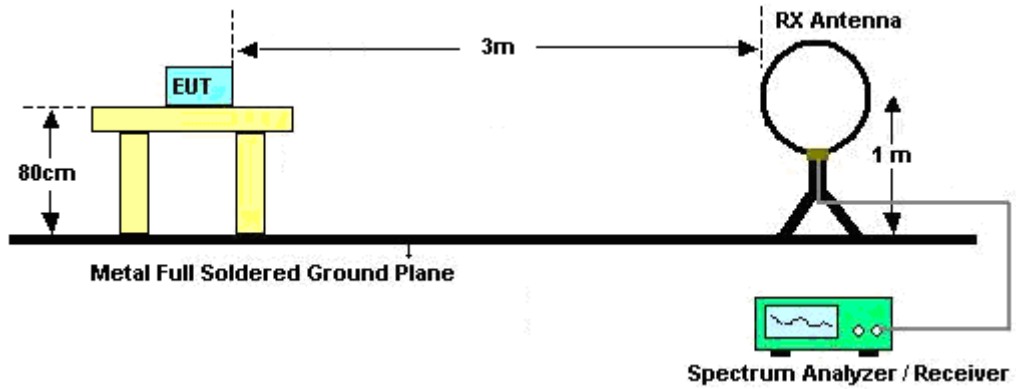

For radiated emissions from 30MHz to 1GHz

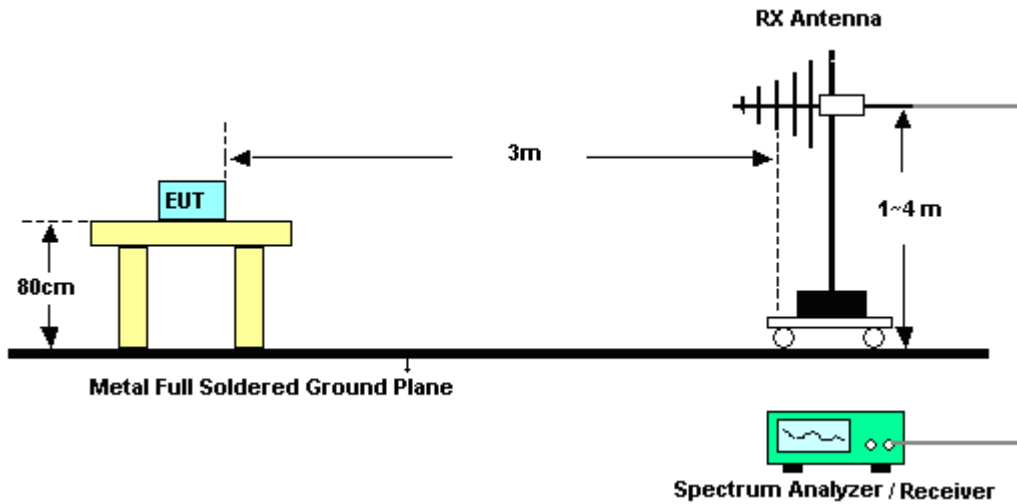

For radiated test from 1GHz to 18GHz

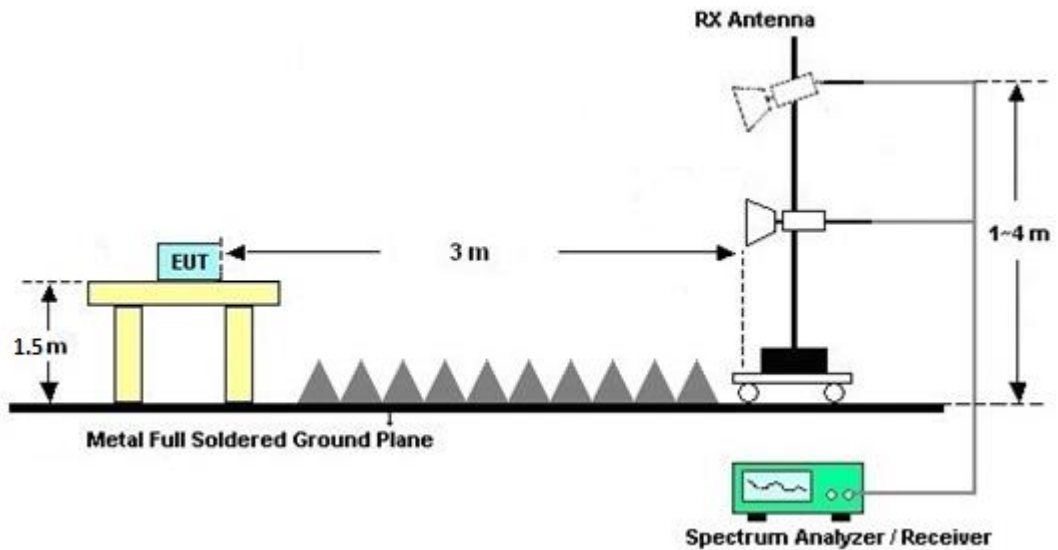

For radiated test above 18GHz

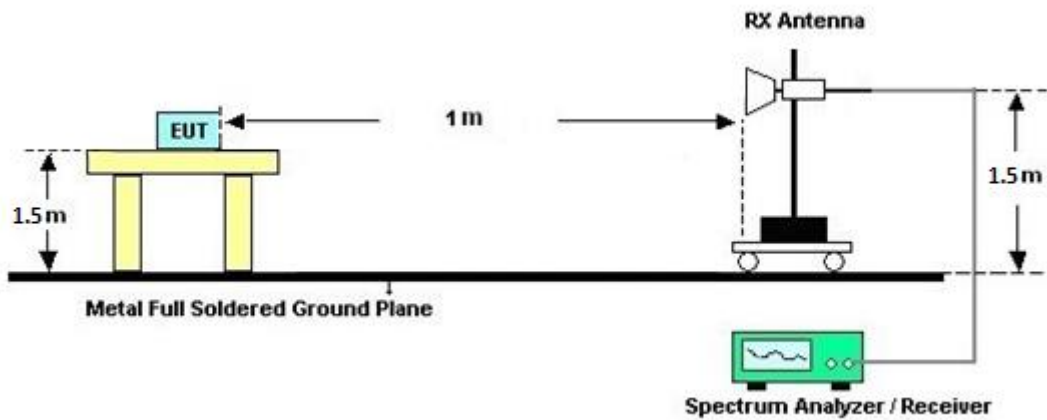

### 3.4.5 Test Results of Radiated Emissions (9 kHz ~ 30 MHz)

The low frequency, which started from 9 kHz to 30MHz, was pre-scanned and the result which was 20dB lower than the limit line was not reported.

There is adequate comparison measurement of both open-field test site and alternative test site - semi-Anechoic chamber according to 414788 D01 Radiated Test Site v01r01, and the result came out very similar.

### 3.4.6 Test Result of Radiated Band Edges

Please refer to Appendix C and D.

### 3.4.7 Duty Cycle

Please refer to Appendix E.

### 3.4.8 Test Result of Unwanted Radiated Emission (30MHz ~ 10th Harmonic)

Please refer to Appendix C and D.





### 3.5 AC Conducted Emission Measurement

#### 3.5.1 Limit of AC Conducted Emission

For equipment that is designed to be connected to the public utility (AC) power line, the radio frequency voltage that is conducted back onto the AC power line on any frequency or frequencies within the band 150 kHz to 30 MHz shall not exceed the limits in the following table.

Frequency of emission (MHz)	Conducted limit (dB $\mu$ V)	
	Quasi-peak	Average
0.15-0.5	66 to 56*	56 to 46*
0.5-5	56	46
5-30	60	50

\*Decreases with the logarithm of the frequency.

#### 3.5.2 Measuring Instruments

See list of measuring equipment of this test report.

#### 3.5.3 Test Procedures

1. The EUT was placed 0.4 meter from the conducting wall of the shielding room was kept at least 80 centimeters from any other grounded conducting surface.
2. Connect EUT to the power mains through a line impedance stabilization network (LISN).
3. All the support units are connecting to the other LISN.
4. The LISN provides 50 ohm coupling impedance for the measuring instrument.
5. The FCC states that a 50 ohm, 50 microhenry LISN shall be used.
6. Both sides of AC line were checked for maximum conducted interference.
7. The frequency range from 150 kHz to 30 MHz was searched.
8. Set the test-receiver system to Peak Detect Function and specified bandwidth with Maximum Hold Mode.

### 3.5.4 Test Setup



### 3.5.5 Test Result of AC Conducted Emission

Please refer to Appendix B.



### 3.6 Antenna Requirements

#### 3.6.1 Standard Applicable

If transmitting antenna directional gain is greater than 6 dBi, both the peak transmit power and the peak power spectral density shall be reduced by the amount in dB that the directional gain of the antenna exceeds 6 dBi.

#### 3.6.2 Antenna Anti-Replacement Construction

An embedded-in antenna design is used.

#### 3.6.3 Antenna Gain

<CDD Modes >

FCC KDB 662911 D01 Multiple Transmitter Output v02r01

For CDD transmissions, directional gain is calculated as

Directional gain =  $G_{ANT}$  + Array Gain, where Array Gain is as follows.

For power spectral density (PSD) measurements on all devices,

Array Gain =  $10 \log(N_{ANT}/N_{SS}=1)$  dB.

For power measurements on IEEE 802.11 devices,

Array Gain = 0 dB (i.e., no array gain) for  $N_{ANT} \leq 4$ .

Directional gain may be calculated by using the formulas applicable to equal gain antennas with  $G_{ANT}$  set equal to the gain of the antenna having the highest gain;

The EUT supports CDD mode.

For power, the directional gain  $G_{ANT}$  is set equal to the antenna having the highest gain, i.e., F)2)f)i).

For PSD, the directional gain calculation is following F)2)f)ii) of KDB 662911 D01 v02r01.

The power and PSD limit should be modified if the directional gain of EUT is over 6 dBi,

The directional gain "DG" is calculated as following table.



<CDD Modes>						
			DG	DG	Power	PSD
			for	for	Limit	Limit
	Ant. 7	Ant. 3	Power	PSD	Reduction	Reduction
	(dBi)	(dBi)	(dBi)	(dBi)	(dB)	(dB)
Band IV	-1.50	-3.60	-1.50	0.52	0.00	0.00

$Power\ Limit\ Reduction = DG(Power) - 6dBi, (min = 0)$

$PSD\ Limit\ Reduction = DG(PSD) - 6dBi, (min = 0)$

Calculation example:

For the Band IV, the DG for PSD is derived from formula is

$$10 \times \log \left\{ \left[ 10^{(-1.50 \text{ dBi} / 20)} + 10^{(-3.60 \text{ dBi} / 20)} \right]^2 / 2 \right\}$$

= 0.52 dBi



## 4 List of Measuring Equipment

Instrument	Brand Name	Model No.	Serial No.	Characteristics	Calibration Date	Test Date	Due Date	Remark
Loop Antenna	Rohde & Schwarz	HFH2-Z2	100315	9 kHz~30 MHz	Jan. 04, 2021	Jul. 03, 2021~ Jul. 20, 2021	Jan. 03, 2022	Radiation (03CH13-HY)
Amplifier	Sonoma-Instrument	310 N	187282	9KHz~1GHz	Dec. 16, 2020	Jul. 03, 2021~ Jul. 20, 2021	Dec. 15, 2021	Radiation (03CH13-HY)
Horn Antenna	SCHWARZBECK	BBHA 9120 D	9120D-02294	1GHz ~ 18GHz	Jun. 23, 2021	Jul. 03, 2021~ Jul. 20, 2021	Jun. 22, 2022	Radiation (03CH13-HY)
Preamplifier	MITEQ	AMF-7D-0010 1800-30-10P	1590074	1GHz~18GHz	May 18, 2021	Jul. 03, 2021~ Jul. 20, 2021	May 17, 2022	Radiation (03CH13-HY)
Preamplifier	Keysight	83017A	MY53270147	1GHz~26.5GHz	Oct. 28, 2020	Jul. 03, 2021~ Jul. 20, 2021	Oct. 27, 2021	Radiation (03CH13-HY)
Signal Generator	Anritsu	MG3694C	163401	0.1Hz~40GHz	Jan. 31, 2021	Jul. 03, 2021~ Jul. 20, 2021	Jan. 30, 2022	Radiation (03CH13-HY)
Spectrum Analyzer	Keysight	N9010A	MY55370526	10Hz~44GHz	Mar. 18, 2021	Jul. 03, 2021~ Jul. 20, 2021	Mar. 17, 2022	Radiation (03CH13-HY)
Controller	EMEC	EM1000	N/A	Control Turn table & Ant Mast	N/A	Jul. 03, 2021~ Jul. 20, 2021	N/A	Radiation (03CH13-HY)
Antenna Mast	EMEC	AM-BS-4500-B	N/A	1m~4m	N/A	Jul. 03, 2021~ Jul. 20, 2021	N/A	Radiation (03CH13-HY)
Turn Table	EMEC	TT2000	N/A	0~360 Degree	N/A	Jul. 03, 2021~ Jul. 20, 2021	N/A	Radiation (03CH13-HY)
Software	Audix	E3 6.2009-8-24	RK-000992	N/A	N/A	Jul. 03, 2021~ Jul. 20, 2021	N/A	Radiation (03CH13-HY)
Preamplifier	EMEC	EM18G40G	060715	18GHz ~ 40GHz	Dec. 11, 2020	Jul. 03, 2021~ Jul. 20, 2021	Dec. 10, 2021	Radiation (03CH13-HY)
RF Cable	HUBER + SUHNER	SUCOFLEX 126E	0030/126E	30M-18G	Feb. 10, 2021	Jul. 03, 2021~ Jul. 20, 2021	Feb. 09, 2022	Radiation (03CH13-HY)
RF Cable	HUBER + SUHNER	SUCOFLEX 104	804793/4	30M-18G	Feb. 10, 2021	Jul. 03, 2021~ Jul. 20, 2021	Feb. 09, 2022	Radiation (03CH13-HY)
RF Cable	HUBER + SUHNER	SUCOFLEX 102	505134/2	30M~40GHz	Feb. 22, 2021	Jul. 03, 2021~ Jul. 20, 2021	Feb. 21, 2022	Radiation (03CH13-HY)
RF Cable	HUBER + SUHNER	SUCOFLEX 102	MY4274/2	30MHz~40GHz	Mar. 11, 2021	Jul. 03, 2021~ Jul. 20, 2021	Mar. 10, 2022	Radiation (03CH13-HY)
RF Cable	HUBER + SUHNER	SUCOFLEX 104	MY24961/4	30M-18G	Feb. 10, 2021	Jul. 03, 2021~ Jul. 20, 2021	Feb. 09, 2022	Radiation (03CH13-HY)
RF Cable	HUBER + SUHNER	SUCOFLEX 104	MY9837/4PE	9kHz~30MHz	Mar. 11, 2021	Jul. 03, 2021~ Jul. 20, 2021	Mar. 10, 2022	Radiation (03CH13-HY)
SHF-EHF Horn Antenna	SCHWARZBECK	BBHA 9170	BBHA917058 4	18GHz- 40GHz	Dec. 11, 2020	Jul. 03, 2021~ Jul. 20, 2021	Dec. 10, 2021	Radiation (03CH13-HY)
Hygrometer	TECPEL	DTM-303B	TP200879	N/A	Oct. 22, 2020	Jul. 03, 2021~ Jul. 20, 2021	Oct. 21, 2021	Radiation (03CH13-HY)
Filter	Wainwright	WHKX8-5872. 5-6750-18000- 40ST	SN5	6.75GHz High Pass Filter	Mar. 11, 2021	Jul. 03, 2021~ Jul. 20, 2021	Mar. 10, 2022	Radiation (03CH13-HY)
Filter	Wainwright	WHKX12-2700 -3000-18000-6 0SS	SN2	3GHz High Pass Filter	May 17, 2021	Jul. 03, 2021~ Jul. 20, 2021	May 16, 2022	Radiation (03CH13-HY)
Hygrometer	Testo	608-H1	34893241	N/A	Mar. 03, 2021	Jun.17, 2021~ Aug. 24, 2021	Mar. 02, 2022	Conducted (TH05-HY)
Power Sensor	DARE	RPR3006W	RPR6W-210 1001	10MHz~8GHz	Feb. 03, 2021	Jun.17, 2021~ Aug. 24, 2021	Feb. 02, 2022	Conducted (TH05-HY)
Signal Analyzer	Rohde & Schwarz	FSV40	101397	10Hz~40GHz	Nov. 27, 2020	Jun.17, 2021~ Aug. 24, 2021	Nov. 26, 2021	Conducted (TH05-HY)
Switch Box & RF Cable	EM Electronics	EMSW18SE	SW200302	N/A	Mar. 17, 2021	Jun.17, 2021~ Aug. 24, 2021	Mar. 16, 2022	Conducted (TH05-HY)



Instrument	Brand Name	Model No.	Serial No.	Characteristics	Calibration Date	Test Date	Due Date	Remark
AC Power Source	ChainTek	APC-1000W	N/A	N/A	N/A	Jul. 07, 2021	N/A	Conduction (CO05-HY)
EMI Test Receiver	Rohde & Schwarz	ESR3	102388	9kHz~3.6GHz	Nov. 30, 2020	Jul. 07, 2021	Nov. 29, 2021	Conduction (CO05-HY)
Hygrometer	Testo	608-H1	34913912	N/A	Nov. 18, 2020	Jul. 07, 2021	Nov. 17, 2021	Conduction (CO05-HY)
LISN	Rohde & Schwarz	ENV216	100081	9kHz~30MHz	Nov. 16, 2020	Jul. 07, 2021	Nov. 15, 2021	Conduction (CO05-HY)
Software	Rohde & Schwarz	EMC32 V10.30	N/A	N/A	N/A	Jul. 07, 2021	N/A	Conduction (CO05-HY)
Pulse Limiter	Rohde & Schwarz	ESH3-Z2	100851	N/A	Feb. 25, 2021	Jul. 07, 2021	Feb. 24, 2022	Conduction (CO05-HY)
LISN Cable	MVE	RG-400	260260	N/A	Dec. 31, 2020	Jul. 07, 2021	Dec. 30, 2021	Conduction (CO05-HY)



## 5 Uncertainty of Evaluation

### Uncertainty of Conducted Emission Measurement (150kHz ~ 30MHz)

Measuring Uncertainty for a Level of Confidence of 95% ( $U = 2Uc(y)$ )	2.3 dB
---	--------

### Uncertainty of Radiated Emission Measurement (30 MHz ~ 1000 MHz)

Measuring Uncertainty for a Level of Confidence of 95% ( $U = 2Uc(y)$ )	5.3 dB
---	--------

### Uncertainty of Radiated Emission Measurement (1000 MHz ~ 18000 MHz)

Measuring Uncertainty for a Level of Confidence of 95% ( $U = 2Uc(y)$ )	5.8 dB
---	--------

### Uncertainty of Radiated Emission Measurement (18000 MHz ~ 40000 MHz)

Measuring Uncertainty for a Level of Confidence of 95% ( $U = 2Uc(y)$ )	3.9 dB
---	--------

**Appendix A. Test Result of Conducted Test Items**

Test Engineer:	Hank Hsu	Temperature:	22.5~25.9	°C
Test Date:	2021/6/17~2021/8/24	Relative Humidity:	45.1~58.7	%



**TEST RESULTS DATA**  
**6dB and 26dB EBW and 99% OBW**

Band IV MIMO												
Mod.	Data Rate	NTX	CH.	Freq. (MHz)	99% Bandwidth (MHz)		26dB Bandwidth (MHz)		6 dB Bandwidth (MHz)		6 dB Bandwidth Min. Limit (MHz)	Pass/Fail
					Ant 7	Ant 3	Ant 7	Ant 3	Ant 7	Ant 3		
11a	6Mbps	2	149	5745	17.18	17.38	21.80	27.40	16.35	16.35	0.5	Pass
11a	6Mbps	2	157	5785	17.23	17.33	21.80	28.05	16.35	16.35	0.5	Pass
11a	6Mbps	2	165	5825	17.23	17.28	21.90	29.50	16.35	16.35	0.5	Pass

**TEST RESULTS DATA**  
**Average Power Table**

Band IV MIMO												
Mod.	Data Rate	NTX	CH.	Freq. (MHz)	Average Conducted Power (dBm)			FCC Conducted Power Limit (dBm)		DG (dBi)		Pass/Fail
					Ant 7	Ant 3	SUM	Ant 7	Ant 3	Ant 7	Ant 3	
11a	6Mbps	2	149	5745	18.15	18.50	21.34	30.00		-1.50	Pass	
11a	6Mbps	2	157	5785	18.05	18.70	21.40	30.00		-1.50	Pass	
11a	6Mbps	2	165	5825	18.15	18.60	21.39	30.00		-1.50	Pass	
HT20	MCS0	2	149	5745	18.85	19.30	22.09	30.00		-1.50	Pass	
HT20	MCS0	2	157	5785	18.85	19.40	22.14	30.00		-1.50	Pass	
HT20	MCS0	2	165	5825	18.55	18.80	21.69	30.00		-1.50	Pass	
HT40	MCS0	2	151	5755	19.25	19.40	22.34	30.00		-1.50	Pass	
HT40	MCS0	2	159	5795	19.35	19.50	22.44	30.00		-1.50	Pass	
VHT20	MCS0	2	149	5745	18.70	19.40	22.07	30.00		-1.50	Pass	
VHT20	MCS0	2	157	5785	18.70	19.50	22.13	30.00		-1.50	Pass	
VHT20	MCS0	2	165	5825	18.40	18.90	21.67	30.00		-1.50	Pass	
VHT40	MCS0	2	151	5755	19.35	19.50	22.44	30.00		-1.50	Pass	
VHT40	MCS0	2	159	5795	19.45	19.60	22.54	30.00		-1.50	Pass	
VHT80	MCS0	2	155	5775	19.85	19.90	22.89	30.00		-1.50	Pass	

**TEST RESULTS DATA**  
**Power Spectral Density**

Band IV MIMO														
Mod.	Data Rate	NTX	CH.	Freq. (MHz)	10log (500kHz /RBW) Factor (dB)		Average Power Density (dBm/500kHz)			Average PSD Limit (dBm/500kHz)		DG (dBi)		Pass /Fail
					Ant 7	Ant 3	Ant 7	Ant 3	SUM	Ant 7	Ant 3	Ant 7	Ant 3	
11a	6Mbps	2	149	5745	2.22	7.21	7.57	10.58	30.00	30.00	0.52	0.52	Pass	
11a	6Mbps	2	157	5785	2.22	7.34	8.05	11.06	30.00	30.00	0.52	0.52	Pass	
11a	6Mbps	2	165	5825	2.22	6.99	7.89	10.90	30.00	30.00	0.52	0.52	Pass	

Note: PSD Sum = Max PSD(Ant. 1, Ant. 2) + 10 log (n)

**TEST RESULTS DATA**  
**6dB and 26dB EBW and 99% OBW**

Band IV MIMO													
Mod.	Data Rate	NTX	CH.	Freq. (MHz)	RU Config	99% Bandwidth (MHz)		26dB Bandwidth (MHz)		6 dB Bandwidth (MHz)		6 dB Bandwidth Min. Limit (MHz)	Pass/Fail
						Ant 7	Ant 3	Ant 7	Ant 3	Ant 7	Ant 3		
HE20	MCS0	2	149	5745	Full	19.38	19.53	28.70	35.90	18.95	18.75	0.5	Pass
HE20	MCS0	2	157	5785	Full	19.28	19.58	28.35	37.65	19.05	18.70	0.5	Pass
HE20	MCS0	2	165	5825	Full	19.23	19.33	24.60	33.45	18.95	18.95	0.5	Pass
HE40	MCS0	2	151	5755	Full	38.26	38.56	57.69	68.22	37.62	37.44	0.5	Pass
HE40	MCS0	2	159	5795	Full	38.16	38.46	60.57	63.63	37.71	37.53	0.5	Pass
HE80	MCS0	2	155	5775	Full	77.32	77.56	121.60	146.72	76.80	76.16	0.5	Pass

**TEST RESULTS DATA**  
**Average Power Table**

Band IV MIMO													
Mod.	Data Rate	NTX	CH.	Freq. (MHz)	RU Config	Average Conducted Power (dBm)			FCC Conducted Power Limit (dBm)		DG (dBi)		Pass/Fail
						Ant 7	Ant 3	SUM	Ant 7	Ant 3	Ant 7	Ant 3	
HE20	MCS0	2	149	5745	Full	19.05	19.50	22.29	30.00	30.00	-1.50	-1.50	Pass
HE20	MCS0	2	149	5745	26/0	11.45	12.10	14.80	30.00	30.00	-1.50	-1.50	Pass
HE20	MCS0	2	149	5745	52/37	13.95	14.60	17.30	30.00	30.00	-1.50	-1.50	Pass
HE20	MCS0	2	149	5745	106/53	16.85	17.30	20.09	30.00	30.00	-1.50	-1.50	Pass
HE20	MCS0	2	157	5785	Full	19.05	19.60	22.34	30.00	30.00	-1.50	-1.50	Pass
HE20	MCS0	2	157	5785	26/4	10.85	11.90	14.42	30.00	30.00	-1.50	-1.50	Pass
HE20	MCS0	2	157	5785	52/38	13.55	14.20	16.90	30.00	30.00	-1.50	-1.50	Pass
HE20	MCS0	2	157	5785	106/53	16.25	17.00	19.65	30.00	30.00	-1.50	-1.50	Pass
HE20	MCS0	2	165	5825	Full	18.75	19.00	21.89	30.00	30.00	-1.50	-1.50	Pass
HE20	MCS0	2	165	5825	26/8	10.45	11.40	13.96	30.00	30.00	-1.50	-1.50	Pass
HE20	MCS0	2	165	5825	52/40	13.25	13.80	16.54	30.00	30.00	-1.50	-1.50	Pass
HE20	MCS0	2	165	5825	106/54	15.95	16.40	19.19	30.00	30.00	-1.50	-1.50	Pass
HE40	MCS0	2	151	5755	Full	19.45	19.60	22.54	30.00	30.00	-1.50	-1.50	Pass
HE40	MCS0	2	159	5795	Full	19.55	19.70	22.64	30.00	30.00	-1.50	-1.50	Pass
HE80	MCS0	2	155	5775	Full	19.95	20.00	22.99	30.00	30.00	-1.50	-1.50	Pass

**TEST RESULTS DATA**  
**Power Spectral Density**

Band IV MIMO															
Mod.	Data Rate	NTX	CH.	Freq. (MHz)	RU Config	10log (500kHz /RBW) Factor (dB)		Average Power Density (dBm/500kHz)			Average PSD Limit (dBm/500kHz)		DG (dBi)		Pass /Fail
						Ant 7	Ant 3	Ant 7	Ant 3	SUM	Ant 7	Ant 3	Ant 7	Ant 3	
HE20	MCS0	2	149	5745	Full	2.22	8.00	8.60	11.61	30.00	30.00	0.52		Pass	
HE20	MCS0	2	149	5745	26/0	2.22	7.57	8.51	11.52	30.00	30.00	0.52		Pass	
HE20	MCS0	2	149	5745	52/37	2.22	7.69	8.21	11.22	30.00	30.00	0.52		Pass	
HE20	MCS0	2	149	5745	106/53	2.22	7.54	8.39	11.40	30.00	30.00	0.52		Pass	
HE20	MCS0	2	157	5785	Full	2.22	8.35	8.94	11.95	30.00	30.00	0.52		Pass	
HE20	MCS0	2	157	5785	26/4	2.22	7.92	8.83	11.84	30.00	30.00	0.52		Pass	
HE20	MCS0	2	157	5785	52/38	2.22	7.82	8.59	11.60	30.00	30.00	0.52		Pass	
HE20	MCS0	2	157	5785	106/53	2.22	7.97	8.85	11.86	30.00	30.00	0.52		Pass	
HE20	MCS0	2	165	5825	Full	2.22	7.89	8.32	11.33	30.00	30.00	0.52		Pass	
HE20	MCS0	2	165	5825	26/8	2.22	7.46	8.19	11.20	30.00	30.00	0.52		Pass	
HE20	MCS0	2	165	5825	52/40	2.22	7.34	7.92	10.93	30.00	30.00	0.52		Pass	
HE20	MCS0	2	165	5825	106/54	2.22	7.58	7.88	10.89	30.00	30.00	0.52		Pass	
HE40	MCS0	2	151	5755	Full	2.22	5.95	6.20	9.21	30.00	30.00	0.52		Pass	
HE40	MCS0	2	159	5795	Full	2.22	6.36	6.37	9.38	30.00	30.00	0.52		Pass	
HE80	MCS0	2	155	5775	Full	2.22	3.73	4.01	7.02	30.00	30.00	0.52		Pass	

Note: PSD Sum = Max PSD(Ant. 1, Ant. 2) + 10 log (n)



## **Appendix B. AC Conducted Emission Test Results**

<b>Test Engineer :</b> Tom Lee	<b>Temperature :</b> 23~26°C
	<b>Relative Humidity :</b> 40~50%

# EUT Information

Report NO : 121931-04  
 Test Mode : Mode 1  
 Test Voltage : 120Vac/60Hz  
 Phase : Line

Full Spectrum

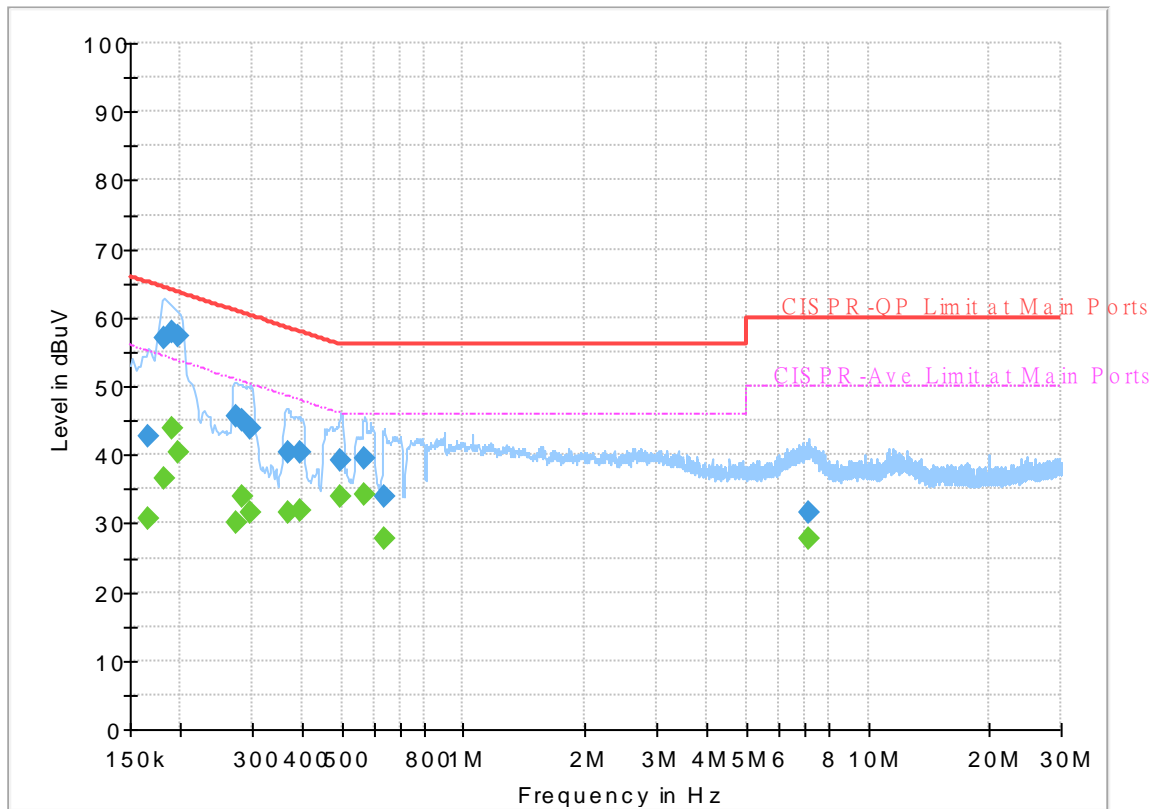

## Final\_Result

Frequency (MHz)	QuasiPeak (dBuV)	CAverage (dBuV)	Limit (dBuV)	Margin (dB)	Line	Filter	Corr. (dB)
0.165750	---	30.62	55.17	24.55	L1	OFF	19.5
0.165750	42.84	---	65.17	22.33	L1	OFF	19.5
0.181500	---	36.68	54.42	17.74	L1	OFF	19.5
0.181500	56.98	---	64.42	7.44	L1	OFF	19.5
0.190500	---	43.95	54.02	10.07	L1	OFF	19.5
0.190500	57.97	---	64.02	6.05	L1	OFF	19.5
0.197250	---	40.37	53.73	13.36	L1	OFF	19.5
0.197250	57.34	---	63.73	6.39	L1	OFF	19.5
0.273750	---	30.24	51.00	20.76	L1	OFF	19.5
0.273750	45.51	---	61.00	15.49	L1	OFF	19.5
0.282750	---	33.78	50.74	16.96	L1	OFF	19.5
0.282750	45.09	---	60.74	15.65	L1	OFF	19.5
0.298500	---	31.63	50.28	18.65	L1	OFF	19.5
0.298500	43.82	---	60.28	16.46	L1	OFF	19.5
0.368250	---	31.50	48.54	17.04	L1	OFF	19.5
0.368250	40.46	---	58.54	18.08	L1	OFF	19.5
0.393000	---	31.90	48.00	16.10	L1	OFF	19.5
0.393000	40.41	---	58.00	17.59	L1	OFF	19.5
0.498750	---	33.99	46.02	12.03	L1	OFF	19.7
0.498750	39.09	---	56.02	16.93	L1	OFF	19.7
0.570750	---	34.12	46.00	11.88	L1	OFF	19.7
0.570750	39.62	---	56.00	16.38	L1	OFF	19.7
0.638250	---	27.91	46.00	18.09	L1	OFF	19.8
0.638250	34.02	---	56.00	21.98	L1	OFF	19.8
7.170000	---	27.68	50.00	22.32	L1	OFF	19.9
7.170000	31.69	---	60.00	28.31	L1	OFF	19.9



# EUT Information

Report NO : 121931-04  
 Test Mode : Mode 1  
 Test Voltage : 120Vac/60Hz  
 Phase : Neutral

Full Spectrum

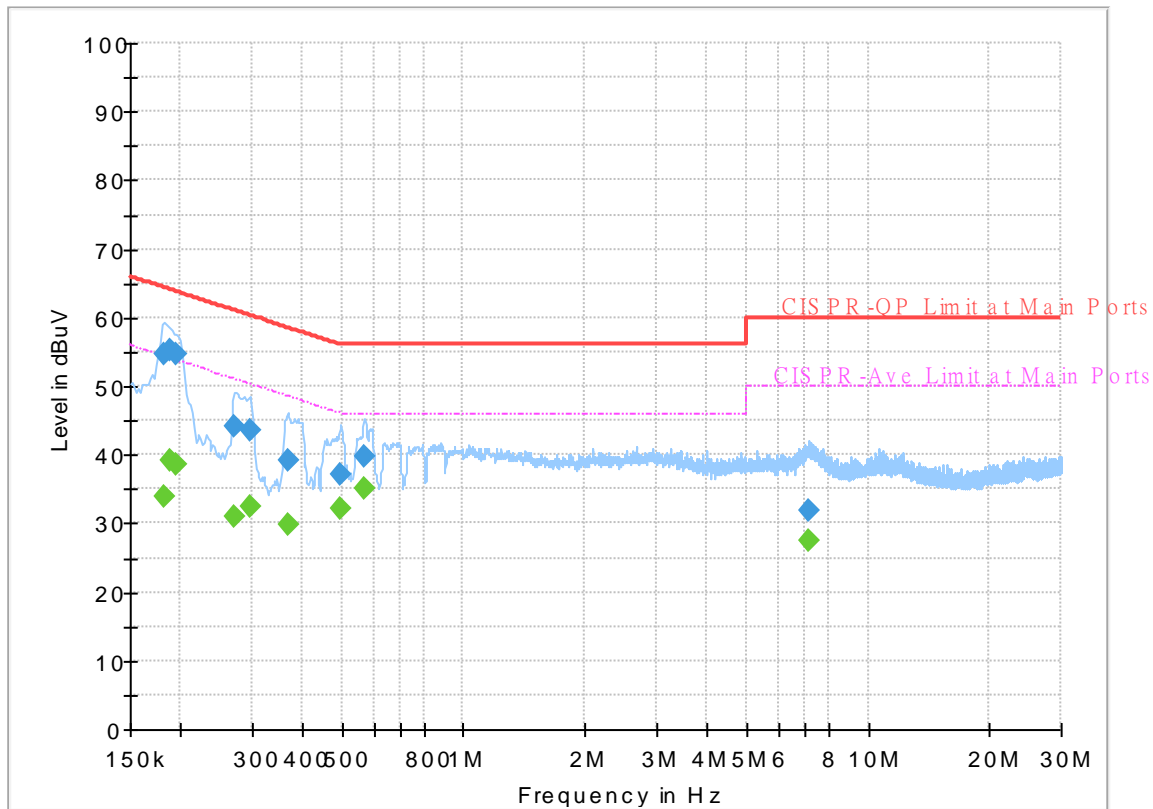

## Final\_Result

Frequency (MHz)	QuasiPeak (dBuV)	CAverage (dBuV)	Limit (dBuV)	Margin (dB)	Line	Filter	Corr. (dB)
0.181500	---	34.01	54.42	20.41	N	OFF	19.5
0.181500	54.53	---	64.42	9.89	N	OFF	19.5
0.188250	---	39.08	54.11	15.03	N	OFF	19.5
0.188250	55.30	---	64.11	8.81	N	OFF	19.5
0.195000	---	38.49	53.82	15.33	N	OFF	19.5
0.195000	54.59	---	63.82	9.23	N	OFF	19.5
0.271500	---	31.08	51.07	19.99	N	OFF	19.5
0.271500	44.08	---	61.07	16.99	N	OFF	19.5
0.296250	---	32.49	50.35	17.86	N	OFF	19.5
0.296250	43.44	---	60.35	16.91	N	OFF	19.5
0.368250	---	29.95	48.54	18.59	N	OFF	19.6
0.368250	39.18	---	58.54	19.36	N	OFF	19.6
0.496500	---	32.27	46.06	13.79	N	OFF	19.7
0.496500	37.27	---	56.06	18.79	N	OFF	19.7
0.568500	---	35.22	46.00	10.78	N	OFF	19.8
0.568500	39.68	---	56.00	16.32	N	OFF	19.8
7.149750	---	27.62	50.00	22.38	N	OFF	20.0
7.149750	31.81	---	60.00	28.19	N	OFF	20.0



### Appendix C. Radiated Spurious Emission

Test Engineer :	Daniel Lee, Jacky Hong, and Wilson Wu	Temperature :	20~25°C
		Relative Humidity :	40~60%

**Band 4 - 5725~5850MHz**  
**WIFI 802.11a (Band Edge @ 3m)**

WIFI	Note	Frequency	Level	Over	Limit	Read	Antenna	Path	Preamp	Ant	Table	Peak	Pol.	
Ant.				Limit	Line	Level	Factor	Loss	Factor	Pos	Pos	Avg.		
7+3		( MHz )	( dBµV/m )	( dB )	( dBµV/m )	( dBµV )	( dB/m )	( dB )	( dB )	( cm )	( deg )	(P/A)	(H/V)	
802.11a CH 149 5745MHz		5600.8	54.25	-13.95	68.2	41.99	33.2	6.45	27.39	258	300	P	H	
		5692.4	55.75	-43.85	99.6	43.25	33.54	6.42	27.46	258	300	P	H	
		5717.8	60.49	-49.69	110.18	47.85	33.71	6.41	27.48	258	300	P	H	
		5723.4	73.74	-44.81	118.55	61.07	33.74	6.41	27.48	258	300	P	H	
	*	5745	110.84	-	-	98.06	33.87	6.41	27.5	258	300	P	H	
	*	5745	103.08	-	-	90.3	33.87	6.41	27.5	258	300	A	H	
														H
														H
			5629.8	52.72	-15.48	68.2	40.49	33.2	6.44	27.41	150	331	P	V
			5698.6	56.84	-47.33	104.17	44.29	33.59	6.42	27.46	150	331	P	V
			5715.6	58.31	-51.26	109.57	45.68	33.69	6.42	27.48	150	331	P	V
			5724	68.6	-51.32	119.92	55.93	33.74	6.41	27.48	150	331	P	V
	*		5745	108.93	-	-	96.15	33.87	6.41	27.5	150	331	P	V
	*		5745	101.68	-	-	88.9	33.87	6.41	27.5	150	331	A	V
													V	
													V	



WIFI Ant. 7+3	Note	Frequency ( MHz )	Level ( dBμV/m )	Over Limit ( dB )	Limit Line ( dBμV/m )	Read Level ( dBμV )	Antenna Factor ( dB/m )	Path Loss ( dB )	Preamp Factor ( dB )	Ant Pos ( cm )	Table Pos ( deg )	Peak Avg. (P/A)	Pol. (H/V)
		5620	54.17	-14.03	68.2	41.94	33.2	6.44	27.41	268	53	P	H
		5680.4	53.78	-36.95	90.73	41.36	33.44	6.43	27.45	268	53	P	H
		5714.4	56.75	-52.48	109.23	44.11	33.69	6.42	27.47	268	53	P	H
		5720	53.53	-57.27	110.8	40.88	33.72	6.41	27.48	268	53	P	H
	*	5785	111.65	-	-	98.82	33.97	6.39	27.53	268	53	P	H
	*	5785	102.76	-	-	89.93	33.97	6.39	27.53	268	53	A	H
		5851.4	51.46	-67.55	119.01	38.5	34.1	6.43	27.57	268	53	P	H
		5861.8	53.7	-55.19	108.89	40.72	34.12	6.44	27.58	268	53	P	H
		5920.2	53.69	-18.05	71.74	40.58	34.24	6.49	27.62	268	53	P	H
		5939.6	52.71	-15.49	68.2	39.56	34.28	6.51	27.64	268	53	P	H
													H
													H
<b>802.11a</b>													
<b>CH 157</b>													
<b>5785MHz</b>		5630.4	53.02	-15.18	68.2	40.79	33.2	6.44	27.41	163	334	P	V
		5656.4	52.76	-20.19	72.95	40.51	33.25	6.43	27.43	163	334	P	V
		5709.6	53.44	-54.45	107.89	40.83	33.66	6.42	27.47	163	334	P	V
		5720	52.99	-57.81	110.8	40.34	33.72	6.41	27.48	163	334	P	V
	*	5785	110.33	-	-	97.5	33.97	6.39	27.53	163	334	P	V
	*	5785	103.16	-	-	90.33	33.97	6.39	27.53	163	334	A	V
		5850.6	52.37	-68.46	120.83	39.41	34.1	6.43	27.57	163	334	P	V
		5867	54.41	-53.03	107.44	41.41	34.13	6.45	27.58	163	334	P	V
		5912	54.09	-23.7	77.79	41	34.22	6.49	27.62	163	334	P	V
		5934.4	53.29	-14.91	68.2	40.15	34.27	6.5	27.63	163	334	P	V
													V
													V



WiFi Ant. 7+3	Note	Frequency ( MHz )	Level ( dBμV/m )	Over Limit ( dB )	Limit Line ( dBμV/m )	Read Level ( dBμV )	Antenna Factor ( dB/m )	Path Loss ( dB )	Preamp Factor ( dB )	Ant Pos ( cm )	Table Pos ( deg )	Peak Avg. ( P/A )	Pol. ( H/V )	
<b>802.11a CH 165 5825MHz</b>	*	5825	110.77	-	-	97.86	34.05	6.41	27.55	272	53	P	H	
	*	5825	101.72	-	-	88.81	34.05	6.41	27.55	272	53	A	H	
		5850.4	59.08	-62.21	121.29	46.12	34.1	6.43	27.57	272	53	P	H	
		5856.4	65.11	-45.3	110.41	52.14	34.11	6.44	27.58	272	53	P	H	
		5884	57.38	-41.14	98.52	44.35	34.17	6.46	27.6	272	53	P	H	
		5925.6	52.23	-15.97	68.2	39.11	34.25	6.5	27.63	272	53	P	H	
														H
														H
	*	5825	110.27	-	-	97.36	34.05	6.41	27.55	161	330	P	V	
	*	5825	102.96	-	-	90.05	34.05	6.41	27.55	161	330	A	V	
		5853.8	63.44	-50.1	113.54	50.46	34.11	6.44	27.57	161	330	P	V	
		5861	60.42	-48.7	109.12	47.44	34.12	6.44	27.58	161	330	P	V	
		5875	55.11	-50.09	105.2	42.1	34.15	6.45	27.59	161	330	P	V	
		5935.8	53.79	-14.41	68.2	40.64	34.27	6.51	27.63	161	330	P	V	
														V
														V
														V
	<b>Remark</b>	1. No other spurious found. 2. All results are PASS against Peak and Average limit line.												



**Band 4 5725~5850MHz**  
**WIFI 802.11a (Harmonic @ 3m)**

WIFI Ant. 7+3	Note	Frequency ( MHz )	Level ( dBμV/m )	Over Limit ( dB )	Limit Line ( dBμV/m )	Read Level ( dBμV )	Antenna Factor ( dB/m )	Path Loss ( dB )	Preamp Factor ( dB )	Ant Pos ( cm )	Table Pos ( deg )	Peak Avg. (P/A)	Pol. (H/V)	
802.11a CH 149 5745MHz		11490	46.96	-27.04	74	53.14	38.92	10.68	55.78	100	0	P	H	
		17235	53.54	-14.66	68.2	59.1	38.03	12.61	56.2	100	0	P	H	
													H	
													H	
													H	
													H	
			11490	46.68	-27.32	74	52.86	38.92	10.68	55.78	100	0	P	V
			17235	64.53	-3.67	68.2	70.09	38.03	12.61	56.2	340	354	P	V
			17912	50.59	-23.41	74	52.99	41.18	13.13	56.71	133	221	P	V
			17912	41.01	-12.99	54	43.41	41.18	13.13	56.71	133	221	A	V
														V
														V
802.11a CH 157 5785MHz		11570	47.53	-26.47	74	53.82	38.76	10.72	55.77	100	0	P	H	
		17355	53.7	-14.5	68.2	59.2	38.21	12.71	56.42	100	0	P	H	
													H	
													H	
													H	
													H	
			11570	46.03	-27.97	74	52.32	38.76	10.72	55.77	100	0	P	V
			17355	64.95	-3.25	68.2	70.45	38.21	12.71	56.42	368	352	P	V
														V
														V
														V
														V



WIFI Ant. 7+3	Note	Frequency ( MHz )	Level ( dBμV/m )	Over Limit ( dB )	Limit Line ( dBμV/m )	Read Level ( dBμV )	Antenna Factor ( dB/m )	Path Loss ( dB )	Preamp Factor ( dB )	Ant Pos ( cm )	Table Pos ( deg )	Peak Avg. (P/A)	Pol. (H/V)	
802.11a CH 165 5825MHz		11650	46.67	-27.33	74	53.03	38.65	10.75	55.76	100	0	P	H	
		17475	53.13	-15.07	68.2	58.59	38.38	12.8	56.64	100	0	P	H	
													H	
													H	
													H	
													H	
			11650	46.53	-27.47	74	52.89	38.65	10.75	55.76	100	0	P	V
			17475	64.72	-3.48	68.2	70.18	38.38	12.8	56.64	362	353	P	V
														V
														V
														V
														V
<b>Remark</b>	1. No other spurious found. 2. All results are PASS against Peak and Average limit line.													



**Band 4 5725~5850MHz**  
**WIFI 802.11ax HE20\_Full (Band Edge @ 3m)**

WIFI Ant. 7+3	Note	Frequency ( MHz )	Level ( dBμV/m )	Over Limit ( dB )	Limit Line ( dBμV/m )	Read Level ( dBμV )	Antenna Factor ( dB/m )	Path Loss ( dB )	Preamp Factor ( dB )	Ant Pos ( cm )	Table Pos ( deg )	Peak Avg. ( P/A )	Pol. ( H/V )	
802.11ax HE20 Full CH 149 5745MHz		5622.2	56.09	-12.11	68.2	43.86	33.2	6.44	27.41	264	53	P	H	
		5692	66.79	-32.51	99.3	54.29	33.54	6.42	27.46	264	53	P	H	
		5720	75.81	-34.99	110.8	63.16	33.72	6.41	27.48	264	53	P	H	
		5723.6	80.67	-38.34	119.01	68	33.74	6.41	27.48	264	53	P	H	
	*	5745	112.03	-	-	99.25	33.87	6.41	27.5	264	53	P	H	
	*	5745	102.89	-	-	90.11	33.87	6.41	27.5	264	53	A	H	
														H
														H
			5613.2	53.19	-15.01	68.2	40.94	33.2	6.45	27.4	165	332	P	V
			5693.6	57.32	-43.16	100.48	44.81	33.55	6.42	27.46	165	332	P	V
			5720	69.24	-41.56	110.8	56.59	33.72	6.41	27.48	165	332	P	V
			5724	74.84	-45.08	119.92	62.17	33.74	6.41	27.48	165	332	P	V
	*		5745	111.43	-	-	98.65	33.87	6.41	27.5	165	332	P	V
	*		5745	102.5	-	-	89.72	33.87	6.41	27.5	165	332	A	V
													V	
													V	



WIFI Ant. 7+3	Note	Frequency ( MHz )	Level ( dBµV/m )	Over Limit ( dB )	Limit Line ( dBµV/m )	Read Level ( dBµV )	Antenna Factor ( dB/m )	Path Loss ( dB )	Preamp Factor ( dB )	Ant Pos ( cm )	Table Pos ( deg )	Peak Avg. (P/A)	Pol. (H/V)
		5636.6	53.95	-14.25	68.2	41.73	33.2	6.44	27.42	259	54	P	H
		5695	54.86	-46.65	101.51	42.34	33.56	6.42	27.46	259	54	P	H
		5712.2	57.18	-51.44	108.62	44.56	33.67	6.42	27.47	259	54	P	H
		5721.6	56.12	-58.33	114.45	43.46	33.73	6.41	27.48	259	54	P	H
	*	5785	112.01	-	-	99.18	33.97	6.39	27.53	259	54	P	H
	*	5785	102.28	-	-	89.45	33.97	6.39	27.53	259	54	A	H
		5851.4	53.18	-65.83	119.01	40.22	34.1	6.43	27.57	259	54	P	H
		5855.8	53.68	-56.9	110.58	40.71	34.11	6.44	27.58	259	54	P	H
		5881.6	54.64	-45.66	100.3	41.61	34.16	6.46	27.59	259	54	P	H
		5932.8	52.4	-15.8	68.2	39.26	34.27	6.5	27.63	259	54	P	H
<b>802.11ax</b>													H
<b>HE20 Full</b>													H
<b>CH 157</b>		5644.4	52.78	-15.42	68.2	40.56	33.2	6.44	27.42	154	336	P	V
<b>5785MHz</b>		5650.8	54.25	-14.54	68.79	42.04	33.21	6.43	27.43	154	336	P	V
		5709.6	52.73	-55.16	107.89	40.12	33.66	6.42	27.47	154	336	P	V
		5723	52.89	-64.75	117.64	40.22	33.74	6.41	27.48	154	336	P	V
	*	5785	112.31	-	-	99.48	33.97	6.39	27.53	154	336	P	V
	*	5785	102.42	-	-	89.59	33.97	6.39	27.53	154	336	A	V
		5854.8	54.31	-56.95	111.26	41.34	34.11	6.44	27.58	154	336	P	V
		5872.8	54.7	-51.12	105.82	41.69	34.15	6.45	27.59	154	336	P	V
		5903.4	53.75	-30.4	84.15	40.67	34.21	6.48	27.61	154	336	P	V
		5932	54.34	-13.86	68.2	41.21	34.26	6.5	27.63	154	336	P	V
													V
													V





WIFI Ant. 7+3	Note	Frequency ( MHz )	Level ( dBμV/m )	Over Limit ( dB )	Limit Line ( dBμV/m )	Read Level ( dBμV )	Antenna Factor ( dB/m )	Path Loss ( dB )	Preamp Factor ( dB )	Ant Pos ( cm )	Table Pos ( deg )	Peak Avg. ( P/A )	Pol. ( H/V )	
802.11ax HE20 Full CH 165 5825MHz	*	5825	111.09	-	-	98.18	34.05	6.41	27.55	262	53	P	H	
	*	5825	100.78	-	-	87.87	34.05	6.41	27.55	262	53	A	H	
		5851.2	66.18	-53.28	119.46	53.22	34.1	6.43	27.57	262	53	P	H	
		5869.4	64.6	-42.17	106.77	51.6	34.14	6.45	27.59	262	53	P	H	
		5875.2	60.78	-44.27	105.05	47.77	34.15	6.45	27.59	262	53	P	H	
		5930.6	53.05	-15.15	68.2	39.92	34.26	6.5	27.63	262	53	P	H	
														H
														H
	*	5825	111.84	-	-	98.93	34.05	6.41	27.55	161	338	P	V	
	*	5825	101.75	-	-	88.84	34.05	6.41	27.55	161	338	A	V	
		5851.2	67.27	-52.19	119.46	54.31	34.1	6.43	27.57	161	338	P	V	
		5856.2	61.52	-48.94	110.46	48.55	34.11	6.44	27.58	161	338	P	V	
		5875	54.75	-50.45	105.2	41.74	34.15	6.45	27.59	161	338	P	V	
		5943.4	53.22	-14.98	68.2	40.06	34.29	6.51	27.64	161	338	P	V	
														V
													V	
<b>Remark</b>	1. No other spurious found. 2. All results are PASS against Peak and Average limit line.													



Band 4 5725~5850MHz

WIFI 802.11ax HE20 Full (Harmonic @ 3m)

WIFI Ant. 7+3	Note	Frequency ( MHz )	Level ( dBμV/m )	Over Limit ( dB )	Limit Line ( dBμV/m )	Read Level ( dBμV )	Antenna Factor ( dB/m )	Path Loss ( dB )	Preamp Factor ( dB )	Ant Pos ( cm )	Table Pos ( deg )	Peak Avg. (P/A)	Pol. (H/V)	
802.11ax HE20 Full CH 149 5745MHz		11490	47.17	-26.83	74	53.35	38.92	10.68	55.78	100	0	P	H	
		17235	54.72	-13.48	68.2	60.28	38.03	12.61	56.2	100	0	P	H	
													H	
													H	
													H	
													H	
														H
														H
														H
														H
802.11ax HE20 Full CH 157 5785MHz		11570	45.27	-28.73	74	51.56	38.76	10.72	55.77	100	0	P	H	
		17355	57.54	-10.66	68.2	63.04	38.21	12.71	56.42	100	0	P	H	
													H	
													H	
													H	
													H	
													H	
													H	
													H	
													H	



WIFI Ant. 7+3	Note	Frequency ( MHz )	Level ( dBμV/m )	Over Limit ( dB )	Limit Line ( dBμV/m )	Read Level ( dBμV )	Antenna Factor ( dB/m )	Path Loss ( dB )	Preamp Factor ( dB )	Ant Pos ( cm )	Table Pos ( deg )	Peak Avg. (P/A)	Pol. (H/V)	
802.11ax HE20 Full CH 165 5825MHz		11650	46.49	-27.51	74	52.85	38.65	10.75	55.76	100	0	P	H	
		17475	55.65	-12.55	68.2	61.11	38.38	12.8	56.64	100	0	P	H	
													H	
													H	
													H	
													H	
			11650	46.71	-27.29	74	53.07	38.65	10.75	55.76	100	0	P	V
			17475	63.83	-4.37	68.2	69.29	38.38	12.8	56.64	321	353	P	V
														V
														V
<b>Remark</b>	<ol style="list-style-type: none"> <li>No other spurious found.</li> <li>All results are PASS against Peak and Average limit line.</li> </ol>													



**Band 4 5725~5850MHz**  
**WIFI 802.11ax HE40\_Full (Band Edge @ 3m)**

WIFI Ant. 7+3	Note	Frequency ( MHz )	Level ( dBμV/m )	Over Limit ( dB )	Limit Line ( dBμV/m )	Read Level ( dBμV )	Antenna Factor ( dB/m )	Path Loss ( dB )	Preamp Factor ( dB )	Ant Pos ( cm )	Table Pos ( deg )	Peak Avg. ( P/A )	Pol. ( H/V )
		5631.8	56.69	-11.51	68.2	44.46	33.2	6.44	27.41	266	56	P	H
		5691	62.78	-35.78	98.56	50.29	33.53	6.42	27.46	266	56	P	H
		5719.2	79.18	-31.4	110.58	66.53	33.72	6.41	27.48	266	56	P	H
		5721.8	81.53	-33.37	114.9	68.87	33.73	6.41	27.48	266	56	P	H
	*	5755	109.55	-	-	96.74	33.91	6.4	27.5	266	56	P	H
	*	5755	100.85	-	-	88.04	33.91	6.4	27.5	266	56	A	H
		5851.4	53.52	-65.49	119.01	40.56	34.1	6.43	27.57	266	56	P	H
		5866.8	54.84	-52.65	107.49	41.84	34.13	6.45	27.58	266	56	P	H
		5905.2	53.53	-29.28	82.81	40.45	34.21	6.48	27.61	266	56	P	H
		5930.4	53.06	-15.14	68.2	39.93	34.26	6.5	27.63	266	56	P	H
<b>802.11ax</b>													H
<b>HE40 Full</b>													H
<b>CH 151</b>		5609.8	54.48	-13.72	68.2	42.23	33.2	6.45	27.4	179	333	P	V
<b>5755MHz</b>		5699.6	60.6	-44.31	104.91	48.04	33.6	6.42	27.46	179	333	P	V
		5716.2	75.52	-34.22	109.74	62.88	33.7	6.42	27.48	179	333	P	V
		5724	78.46	-41.46	119.92	65.79	33.74	6.41	27.48	179	333	P	V
	*	5755	110.79	-	-	97.98	33.91	6.4	27.5	179	333	P	V
	*	5755	100.61	-	-	87.8	33.91	6.4	27.5	179	333	A	V
		5854.4	54.88	-57.29	112.17	41.91	34.11	6.44	27.58	179	333	P	V
		5873	54.55	-51.21	105.76	41.54	34.15	6.45	27.59	179	333	P	V
		5890.2	54.51	-39.41	93.92	41.46	34.18	6.47	27.6	179	333	P	V
		5947.2	53.56	-14.64	68.2	40.39	34.29	6.52	27.64	179	333	P	V
													V
													V



WIFI Ant. 7+3	Note	Frequency ( MHz )	Level ( dBµV/m )	Over Limit ( dB )	Limit Line ( dBµV/m )	Read Level ( dBµV )	Antenna Factor ( dB/m )	Path Loss ( dB )	Preamp Factor ( dB )	Ant Pos ( cm )	Table Pos ( deg )	Peak Avg. (P/A)	Pol. (H/V)
		5648	56.93	-11.27	68.2	44.72	33.2	6.44	27.43	260	54	P	H
		5675.2	58.22	-28.67	86.89	45.84	33.4	6.43	27.45	260	54	P	H
		5712.8	60.71	-48.08	108.79	48.08	33.68	6.42	27.47	260	54	P	H
		5725	62.44	-59.76	122.2	49.76	33.75	6.41	27.48	260	54	P	H
	*	5795	108.73	-	-	95.88	33.99	6.39	27.53	260	54	P	H
	*	5795	100.28	-	-	87.43	33.99	6.39	27.53	260	54	A	H
		5850.8	58.58	-61.8	120.38	45.62	34.1	6.43	27.57	260	54	P	H
		5861	59.96	-49.16	109.12	46.98	34.12	6.44	27.58	260	54	P	H
		5876.6	55.26	-48.75	104.01	42.24	34.15	6.46	27.59	260	54	P	H
		5947.8	52.94	-15.26	68.2	39.76	34.3	6.52	27.64	260	54	P	H
802.11ax													H
HE40 Full													H
CH 159		5631.2	52.7	-15.5	68.2	40.47	33.2	6.44	27.41	163	333	P	V
5795MHz		5659.2	53.73	-21.3	75.03	41.46	33.27	6.43	27.43	163	333	P	V
		5715.8	55.18	-54.45	109.63	42.55	33.69	6.42	27.48	163	333	P	V
		5724.2	56.69	-63.69	120.38	44.01	33.75	6.41	27.48	163	333	P	V
	*	5795	110.4	-	-	97.55	33.99	6.39	27.53	163	333	P	V
	*	5795	100.77	-	-	87.92	33.99	6.39	27.53	163	333	A	V
		5854.4	61.4	-50.77	112.17	48.43	34.11	6.44	27.58	163	333	P	V
		5859	59.92	-49.76	109.68	46.94	34.12	6.44	27.58	163	333	P	V
		5882.2	56.6	-43.25	99.85	43.58	34.16	6.46	27.6	163	333	P	V
		5926.8	54.14	-14.06	68.2	41.02	34.25	6.5	27.63	163	333	P	V
													V
													V
Remark	1. No other spurious found. 2. All results are PASS against Peak and Average limit line.												



**Band 4 5725~5850MHz**  
**WIFI 802.11ax HE40\_Full (Harmonic @ 3m)**

WIFI Ant. 7+3	Note	Frequency ( MHz )	Level ( dBμV/m )	Over Limit ( dB )	Limit Line ( dBμV/m )	Read Level ( dBμV )	Antenna Factor ( dB/m )	Path Loss ( dB )	Preamp Factor ( dB )	Ant Pos ( cm )	Table Pos ( deg )	Peak Avg. ( P/A )	Pol. ( H/V )	
802.11ax HE40 Full CH 151 5755MHz		11510	46.27	-27.73	74	52.48	38.88	10.69	55.78	100	0	P	H	
		17265	56.58	-11.62	68.2	62.14	38.06	12.64	56.26	100	0	P	H	
													H	
													H	
													H	
													H	
														H
														H
														H
														H
802.11ax HE40 Full CH 159 5795MHz		11590	46	-28	74	52.32	38.72	10.73	55.77	100	0	P	H	
		17385	54.64	-13.56	68.2	60.12	38.27	12.73	56.48	100	0	P	H	
													H	
													H	
													H	
													H	
														H
														H
														H
														H
Remark	1. No other spurious found.													
	2. All results are PASS against Peak and Average limit line.													



**Band 4 5725~5850MHz**  
**WIFI 802.11ax HE80\_Full (Band Edge @ 3m)**

WIFI Ant. 7+3	Note	Frequency ( MHz )	Level ( dBμV/m )	Over Limit ( dB )	Limit Line ( dBμV/m )	Read Level ( dBμV )	Antenna Factor ( dB/m )	Path Loss ( dB )	Preamp Factor ( dB )	Ant Pos ( cm )	Table Pos ( deg )	Peak Avg. ( P/A )	Pol. ( H/V )
		5648.6	58.82	-9.38	68.2	46.61	33.2	6.44	27.43	265	55	P	H
		5697.4	75.03	-28.25	103.28	62.49	33.58	6.42	27.46	265	55	P	H
		5715.4	80.01	-29.5	109.51	67.38	33.69	6.42	27.48	265	55	P	H
		5723.8	80.57	-38.89	119.46	67.9	33.74	6.41	27.48	265	55	P	H
	*	5775	108.9	-	-	96.07	33.95	6.4	27.52	265	55	P	H
	*	5775	98.41	-	-	85.58	33.95	6.4	27.52	265	55	A	H
		5852.2	72.88	-44.3	117.18	59.92	34.1	6.43	27.57	265	55	P	H
		5856.6	70.96	-39.39	110.35	57.99	34.11	6.44	27.58	265	55	P	H
		5875.2	62.02	-43.03	105.05	49.01	34.15	6.45	27.59	265	55	P	H
		5931.2	54.2	-14	68.2	41.07	34.26	6.5	27.63	265	55	P	H
<b>802.11ax</b>													H
<b>HE80 Full</b>													H
<b>CH 155</b>		5644.8	56.48	-11.72	68.2	44.26	33.2	6.44	27.42	162	334	P	V
<b>5775MHz</b>		5694.8	72.05	-29.32	101.37	59.53	33.56	6.42	27.46	162	334	P	V
		5716	76.65	-33.03	109.68	64.01	33.7	6.42	27.48	162	334	P	V
		5723.8	78	-41.46	119.46	65.33	33.74	6.41	27.48	162	334	P	V
	*	5775	107.41	-	-	94.58	33.95	6.4	27.52	162	334	P	V
	*	5775	98.44	-	-	85.61	33.95	6.4	27.52	162	334	A	V
		5850.6	74.83	-46	120.83	61.87	34.1	6.43	27.57	162	334	P	V
		5856.6	72.76	-37.59	110.35	59.79	34.11	6.44	27.58	162	334	P	V
		5880.4	64.93	-36.26	101.19	51.9	34.16	6.46	27.59	162	334	P	V
		5940.4	56.27	-11.93	68.2	43.12	34.28	6.51	27.64	162	334	P	V
													V
													V
<b>Remark</b>	1. No other spurious found. 2. All results are PASS against Peak and Average limit line.												



**Band 4 5725~5850MHz**

**WIFI 802.11ax HE80\_Full (Harmonic @ 3m)**

WIFI Ant. 7+3	Note	Frequency ( MHz )	Level ( dBμV/m )	Over Limit ( dB )	Limit Line ( dBμV/m )	Read Level ( dBμV )	Antenna Factor ( dB/m )	Path Loss ( dB )	Preamp Factor ( dB )	Ant Pos ( cm )	Table Pos ( deg )	Peak Avg. ( P/A )	Pol. ( H/V )	
802.11ax HE80 Full CH 155 5775MHz		11550	45.3	-28.7	74	51.56	38.8	10.71	55.77	100	0	P	H	
		17325	52.57	-15.63	68.2	58.1	38.15	12.69	56.37	100	0	P	H	
													H	
													H	
													H	
													H	
														H
			11550	45.6	-28.4	74	51.86	38.8	10.71	55.77	100	0	P	V
			17325	58.16	-10.04	68.2	63.69	38.15	12.69	56.37	100	0	P	V
														V
													V	
													V	
													V	
<b>Remark</b>	1. No other spurious found. 2. All results are PASS against Peak and Average limit line.													





Emission above 18GHz

WIFI 802.11a (SHF @ 1m)

WIFI	Note	Frequency	Level	Over	Limit	Read	Antenna	Path	Preamp	Ant	Table	Peak	Pol.
Ant.				Limit	Line	Level	Factor	Loss	Factor	Pos	Pos	Avg.	
7+3		( MHz )	( dBμV/m )	( dB )	( dBμV/m )	( dBμV )	( dB/m )	( dB )	( dB )	( cm )	( deg )	( P/A )	( H/V )
802.11a SHF		36348	46.22	-21.98	68.2	62.71	43.3	-1.27	58.52	150	0	P	H
													H
													H
													H
													H
													H
													H
													H
													H
													H
													H
													H
													H
													H
													H
													H
													H
													H
			35974	45.95	-22.25	68.2	63.14	42.76	-1.14	58.81	150	0	P
													V
													V
													V
													V
													V
													V
													V
													V
													V
													V
													V
													V
													V
													V
Remark	1. No other spurious found. 2. All results are PASS against limit line.												





**Note symbol**

*	<b>Fundamental Frequency</b> which can be ignored. However, the level of any unwanted emissions shall not exceed the level of the fundamental frequency.
!	Test result is <b>over limit</b> line.
P/A	<b>Peak</b> or <b>Average</b>
H/V	<b>Horizontal</b> or <b>Vertical</b>



A calculation example for radiated spurious emission is shown as below:

WIFI	Note	Frequency	Level	Over	Limit	Read	Antenna	Path	Preamp	Ant	Table	Peak	Pol.
Ant.				Limit	Line	Level	Factor	Loss	Factor	Pos	Pos	Avg.	
1+2		( MHz )	( dBμV/m )	( dB )	( dBμV/m )	( dBμV )	( dB/m )	( dB )	( dB )	( cm )	( deg )	( P/A )	( H/V )
802.11b		2390	55.45	-18.55	74	54.51	32.22	4.58	35.86	103	308	P	H
CH 01													
2412MHz		2390	43.54	-10.46	54	42.6	32.22	4.58	35.86	103	308	A	H

1. Path Loss(dB) = Cable loss(dB) + Filter loss(dB) + Attenuator loss(dB)
2. Level(dBμV/m) = Antenna Factor(dB/m) + Path Loss(dB) + Read Level(dBμV) - Preamp Factor(dB)
3. Over Limit(dB) = Level(dBμV/m) – Limit Line(dBμV/m)

**For Peak Limit @ 2390MHz:**

1. Level(dBμV/m)  
= Antenna Factor(dB/m) + Path Loss(dB) + Read Level(dBμV) - Preamp Factor(dB)  
= 32.22(dB/m) + 4.58(dB) + 54.51(dBμV) – 35.86 (dB)  
= 55.45 (dBμV/m)
2. Over Limit(dB)  
= Level(dBμV/m) – Limit Line(dBμV/m)  
= 55.45(dBμV/m) – 74(dBμV/m)  
= -18.55(dB)

**For Average Limit @ 2390MHz:**

1. Level(dBμV/m)  
= Antenna Factor(dB/m) + Path Loss(dB) + Read Level(dBμV) - Preamp Factor(dB)  
= 32.22(dB/m) + 4.58(dB) + 42.6(dBμV) – 35.86 (dB)  
= 43.54 (dBμV/m)
2. Over Limit(dB) = Level(dBμV/m) – Limit Line(dBμV/m)  
= 43.54(dBμV/m) – 54(dBμV/m)  
= -10.46(dB)

**Both peak and average measured complies with the limit line, so test result is “PASS”.**



## Appendix D. Radiated Spurious Emission Plots

Test Engineer :	Daniel Lee, Jacky Hong and Wilson Wu	Temperature :	20~25°C
		Relative Humidity :	40~60%

### Band 4 - 5725~5850MHz

### WIFI 802.11a (Band Edge @ 3m)

WIFI	Band 4 5725~5850MHz Band Edge @ 3m	
ANT	802.11a CH149 5745MHz	
7+3	Horizontal	Fundamental
Peak	<p>Site Condition : 03CH13-HY : PEAK_BE(B4)_16-24 3m 91200-02294 HORIZONTAL : RBW:1000.000KHz VBW:3000.000KHz SWT:Auto</p>	<p>Site Condition : 03CH13-HY : PEAK(UNII) 3m 91200-02294 HORIZONTAL : RBW:1000.000KHz VBW:3000.000KHz SWT:Auto</p>



WIFI	Band 4 5725~5850MHz Band Edge @ 3m	
ANT	802.11a CH149 5745MHz	
7+3	Vertical	Fundamental
Peak	<p>Site : 03CH13-HY Condition : PEAK_SE[84]_16-24 3m 91200-02294 VERTICAL RBW:1000.000kHz VSW:3000.000kHz SWT:Auto</p>	<p>Site : 03CH13-HY Condition : PEAK[LINE] 3m 91200-02294 VERTICAL RBW:1000.000kHz VSW:3000.000kHz SWT:Auto</p>



WIFI	Band 4 5725~5850MHz Band Edge @ 3m	
ANT	802.11a CH157 5785MHz	
7+3	Horizontal	Fundamental
Peak	<p>Site : 03CH13-HY Condition : PEAK_BE(B4)_16-24 3m 91200-02294 HORIZONTAL RBW:1000.000KHz VBW:3000.000KHz SWF:Auto</p>	<p>Site : 03CH13-HY Condition : PEAK(LINE1) 3m 91200-02294 HORIZONTAL RBW:1000.000KHz VBW:3000.000KHz SWF:Auto</p>
Peak	<p>Site : 03CH13-HY Condition : PEAK_BE(B4)_16-24 3m 91200-02294 HORIZONTAL RBW:1000.000KHz VBW:3000.000KHz SWF:Auto</p>	Left blank

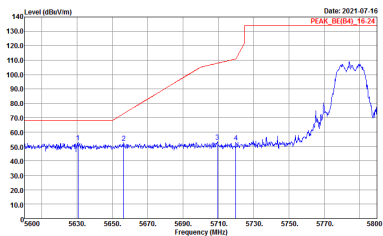
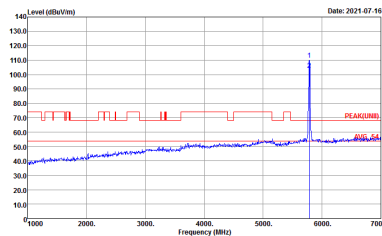
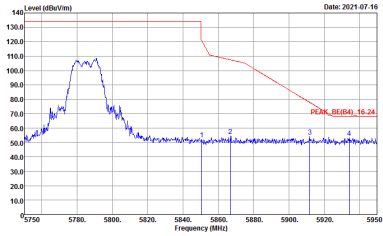

WIFI	Band 4 5725~5850MHz Band Edge @ 3m	
ANT	802.11a CH157 5785MHz	
7+3	Vertical	Fundamental
Peak	 <p>Site : 03CH13-HY Condition : PEAK_BE(B4)_16-24 3m 91200-02294 VERTICAL RBW:1000.000KHz VBW:3000.000KHz SWT:Auto</p>	 <p>Site : 03CH13-HY Condition : PEAK(LINE1) 3m 91200-02294 VERTICAL RBW:1000.000KHz VBW:3000.000KHz SWT:Auto</p>
Peak	 <p>Site : 03CH13-HY Condition : PEAK_BE(B4)_16-24 3m 91200-02294 VERTICAL RBW:1000.000KHz VBW:3000.000KHz SWT:Auto</p>	Left blank



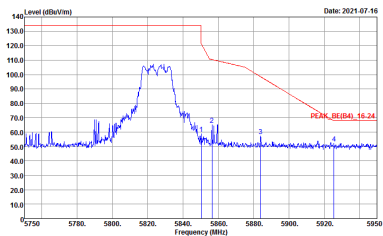
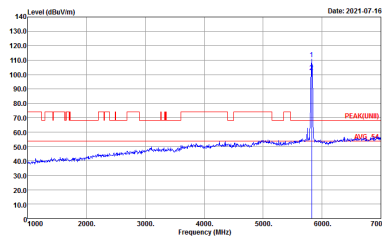

WIFI	Band 4 5725~5850MHz Band Edge @ 3m	
ANT	802.11a CH165 5825MHz	
7+3	Horizontal	Fundamental
Peak	 <p>Site : 03CH13-HY Condition : PEAK_SE[84]_16-24 3m 91200-02294 HORIZONTAL RBW:1000.000kHz VSW:3000.000kHz SWF:Auto</p>	 <p>Site : 03CH13-HY Condition : PEAK[LINE1] 3m 91200-02294 HORIZONTAL RBW:1000.000kHz VSW:3000.000kHz SWF:Auto</p>

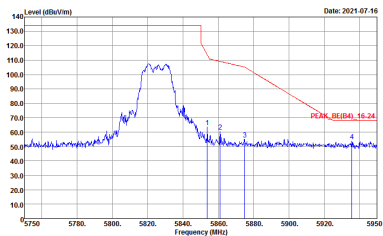
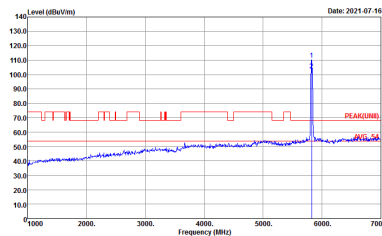

WIFI	Band 4 5725~5850MHz Band Edge @ 3m	
ANT	802.11a CH165 5825MHz	
7+3	Vertical	Fundamental
Peak	 <p>Site : 03CH13-HY Condition : PEAK_SE[84]_16-24 3m 91200-02294 VERTICAL RBW:1000.000kHz VSW:3000.000kHz SWT:Auto</p>	 <p>Site : 03CH13-HY Condition : PEAK[LINE1] 3m 91200-02294 VERTICAL RBW:1000.000kHz VSW:3000.000kHz SWT:Auto</p>



**Band 4 5725~5850MHz**  
**WIFI 802.11ax HE20 Full (Band Edge @ 3m)**

<b>WIFI</b>	<b>Band 4 5725~5850MHz Band Edge @ 3m</b>	
<b>ANT</b>	<b>802.11ax HE20 Full CH149 5745MHz</b>	
<b>7+3</b>	<b>Horizontal</b>	<b>Fundamental</b>
<b>Peak</b>	<p>Date: 2021-07-16 PEAK_BE(84)_16-24</p> <p>Site : 03CH13-HY Condition : PEAK_BE(84)_16-24 3m 91200-02294 HORIZONTAL : RBW:1000.000KHz VBW:3000.000KHz SWT:Auto</p>	<p>Date: 2021-07-16 PEAK(UNB)_16-24</p> <p>Site : 03CH13-HY Condition : PEAK(UNB)_16-24 3m 91200-02294 HORIZONTAL : RBW:1000.000KHz VBW:3000.000KHz SWT:Auto</p>



WIFI	Band 4 5725~5850MHz Band Edge @ 3m	
ANT	802.11ax HE20 Full CH149 5745MHz	
7+3	Vertical	Fundamental
Peak	<p>Site : 03CH13-HY Condition : PEAK_SE[84]_16-24 3m 91200-02294 VERTICAL RBW:1000.000kHz VSW:3000.000kHz SWT:Auto</p> <p>Date: 2021-07-16 PEAK_REF[84]_16-24</p>	<p>Site : 03CH13-HY Condition : PEAK[LINE1]_3m 91200-02294 VERTICAL RBW:1000.000kHz VSW:3000.000kHz SWT:Auto</p> <p>Date: 2021-07-16 PEAK[LINE1]</p>

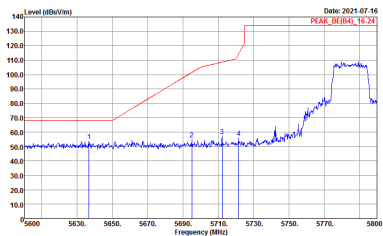
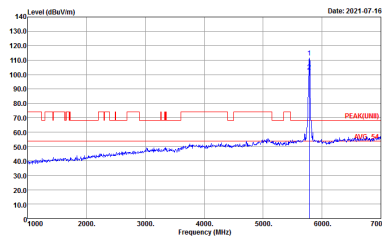
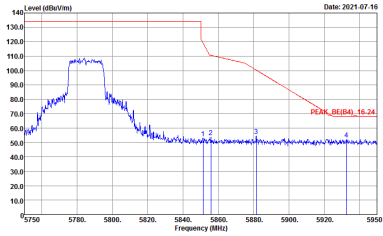

WIFI	Band 4 5725~5850MHz Band Edge @ 3m	
ANT	802.11ax HE20 Full CH157 5785MHz	
7+3	Horizontal	Fundamental
Peak	 <p>Site : 03CH13-HY Condition : PEAK_BE(B4)_16-24 3m 91200-02294 HORIZONTAL RBW:1000.000KHz VBW:3000.000KHz SWF:Auto</p>	 <p>Site : 03CH13-HY Condition : PEAK(LINE1) 3m 91200-02294 HORIZONTAL RBW:1000.000KHz VBW:3000.000KHz SWF:Auto</p>
Peak	 <p>Site : 03CH13-HY Condition : PEAK_BE(B4)_16-24 3m 91200-02294 HORIZONTAL RBW:1000.000KHz VBW:3000.000KHz SWF:Auto</p>	Left blank

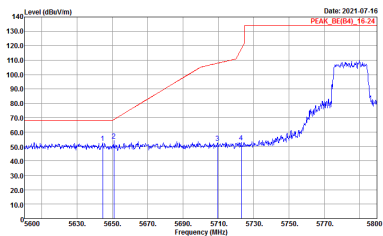
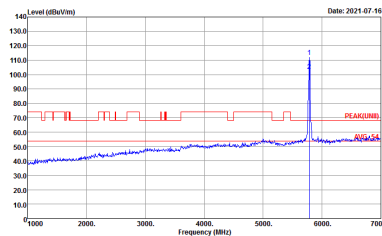
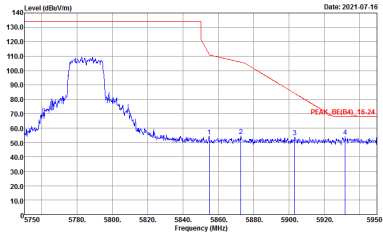

WIFI	Band 4 5725~5850MHz Band Edge @ 3m	
ANT	802.11ax HE20 Full CH157 5785MHz	
7+3	Vertical	Fundamental
Peak	 <p>Date: 2021-07-16 PEAK_BE(B4)_16-24</p> <p>Site : 03CH13-HY Condition : PEAK_BE(B4)_16-24 3m 91200-02294 VERTICAL RBW:1000.000KHz VBW:3000.000KHz SWT:Auto</p>	 <p>Date: 2021-07-16 PEAK(LINE)</p> <p>Site : 03CH13-HY Condition : PEAK(LINE) 3m 91200-02294 VERTICAL RBW:1000.000KHz VBW:3000.000KHz SWT:Auto</p>
Peak	 <p>Date: 2021-07-16 PEAK_BE(B4)_16-24</p> <p>Site : 03CH13-HY Condition : PEAK_BE(B4)_16-24 3m 91200-02294 VERTICAL RBW:1000.000KHz VBW:3000.000KHz SWT:Auto</p>	Left blank



WIFI	Band 4 5725~5850MHz Band Edge @ 3m	
ANT	802.11ax HE20 Full CH165 5825MHz	
7+3	Horizontal	Fundamental
Peak	<p>Site : 03CH13-HY Condition : PEAK_SE[84]_16-24 3m 91200-02294 HORIZONTAL RBW:1000.000kHz VSW:3000.000kHz SWT:Auto</p>	<p>Site : 03CH13-HY Condition : PEAK[LINE1] 3m 91200-02294 HORIZONTAL RBW:1000.000kHz VSW:3000.000kHz SWT:Auto</p>

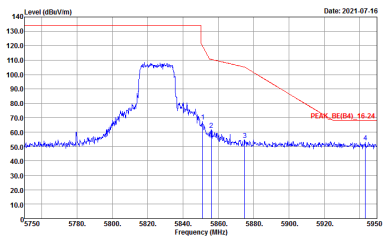
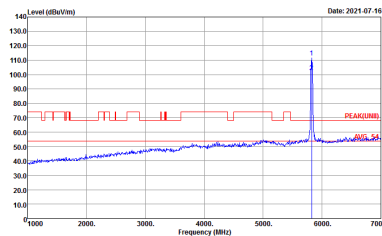

WIFI	Band 4 5725~5850MHz Band Edge @ 3m	
ANT	802.11ax HE20 Full CH165 5825MHz	
7+3	Vertical	Fundamental
Peak	 <p>Site : :03CH13-HY Condition : :PEAK_SE[84]_16-24 3m 91200-02294 VERTICAL :RBW:1000.000kHz :VBW:3000.000kHz :SWT:Auto</p>	 <p>Site : :03CH13-HY Condition : :PEAK[LINE1] 3m 91200-02294 VERTICAL :RBW:1000.000kHz :VBW:3000.000kHz :SWT:Auto</p>





**Band 4 5725~5850MHz**  
**WIFI 802.11ax HE40 Full (Band Edge @ 3m)**

WIFI	Band 4 5725~5850MHz Band Edge @ 3m	
ANT	802.11ax HE40 Full CH151 5755MHz	
7+3	Horizontal	Fundamental
Peak	<p>Site : 03CH13-HY            Condition : PEAK_BE(B4)_16-24 3m 91200-02294 HORIZONTAL            : RBW:1000.000KHz VBW:3000.000KHz SWT:Auto</p>	<p>Site : 03CH13-HY            Condition : PEAK(UNB) 3m 91200-02294 HORIZONTAL            : RBW:1000.000KHz VBW:3000.000KHz SWT:Auto</p>
Peak	<p>Site : 03CH13-HY            Condition : PEAK_BE(B4)_16-24 3m 91200-02294 HORIZONTAL            : RBW:1000.000KHz VBW:3000.000KHz SWT:Auto</p>	Left blank



WIFI	Band 4 5725~5850MHz Band Edge @ 3m	
ANT	802.11ax HE40 Full CH151 5755MHz	
7+3	Vertical	Fundamental
Peak	<p>Site : 03CH13-HY Condition : PEAK_BE(B4)_16-24 3m 91200-02294 VERTICAL RBW:1000.000KHz VBW:3000.000KHz SWT:Auto</p>	<p>Site : 03CH13-HY Condition : PEAK(FUN1) 3m 91200-02294 VERTICAL RBW:1000.000KHz VBW:3000.000KHz SWT:Auto</p>
Peak	<p>Site : 03CH13-HY Condition : PEAK_BE(B4)_16-24 3m 91200-02294 VERTICAL RBW:1000.000KHz VBW:3000.000KHz SWT:Auto</p>	Left blank

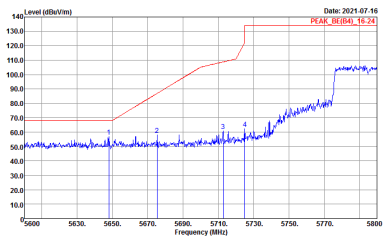
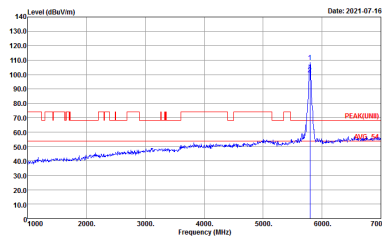
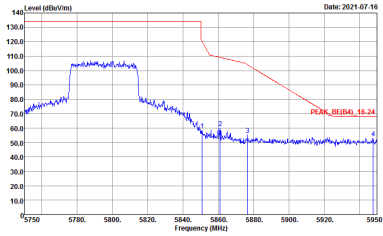

WIFI	Band 4 5725~5850MHz Band Edge @ 3m	
ANT	802.11ax HE40 Full HT40 CH159 5795MHz	
7+3	Horizontal	Fundamental
Peak	 <p>Site : 03CH13-HY Condition : PEAK_BE(B4)_16-24 3m 91200-02294 HORIZONTAL RBW:1000.000KHz VBW:3000.000KHz SWF:Auto</p>	 <p>Site : 03CH13-HY Condition : PEAK(LINE1) 3m 91200-02294 HORIZONTAL RBW:1000.000KHz VBW:3000.000KHz SWF:Auto</p>
Peak	 <p>Site : 03CH13-HY Condition : PEAK_BE(B4)_16-24 3m 91200-02294 HORIZONTAL RBW:1000.000KHz VBW:3000.000KHz SWF:Auto</p>	Left blank

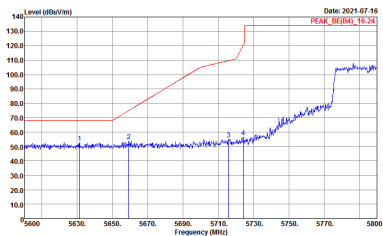
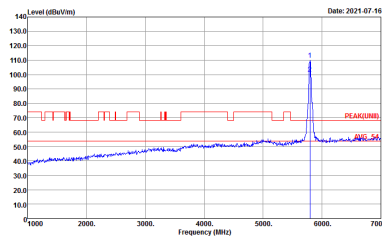
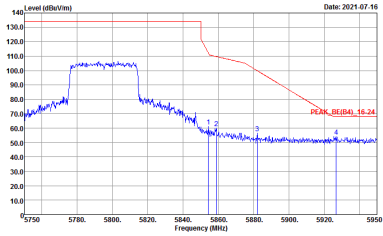

WIFI	Band 4 5725~5850MHz Band Edge @ 3m	
ANT	802.11ax HE40 Full CH159 5795MHz	
7+3	Vertical	Fundamental
Peak	 <p>Site : 03CH13-HY Condition : PEAK_BE(B4)_16-24 3m 91200-02294 VERTICAL RBW:1000.000KHz VBW:3000.000KHz SWT:Auto</p>	 <p>Site : 03CH13-HY Condition : PEAK(LINE1) 3m 91200-02294 VERTICAL RBW:1000.000KHz VBW:3000.000KHz SWT:Auto</p>
Peak	 <p>Site : 03CH13-HY Condition : PEAK_BE(B4)_16-24 3m 91200-02294 VERTICAL RBW:1000.000KHz VBW:3000.000KHz SWT:Auto</p>	Left blank



**Band 4 5725~5850MHz**  
**WIFI 802.11ax HE80 Full (Band Edge @ 3m)**

WIFI	Band 4 5725~5850MHz Band Edge @ 3m	
ANT	802.11ax HE80 Full CH155 5775MHz	
7+3	Horizontal	Fundamental
Peak	<p>Site : 03CH13-HY            Condition : PEAK_BE(B4)_16-24 3m 91200-02294 HORIZONTAL            : RBW:1000.000KHz VBW:3000.000KHz SWT:Auto</p>	<p>Site : 03CH13-HY            Condition : PEAK(UNB) 3m 91200-02294 HORIZONTAL            : RBW:1000.000KHz VBW:3000.000KHz SWT:Auto</p>
Peak	<p>Site : 03CH13-HY            Condition : PEAK_BE(B4)_16-24 3m 91200-02294 HORIZONTAL            : RBW:1000.000KHz VBW:3000.000KHz SWT:Auto</p>	Left blank

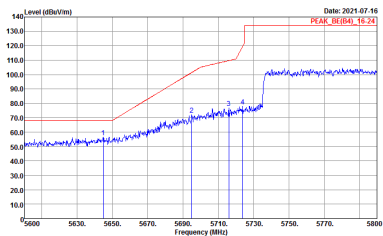
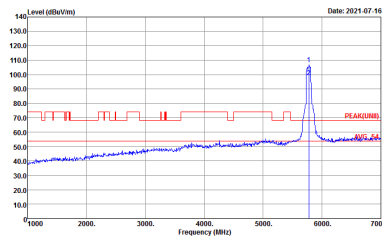
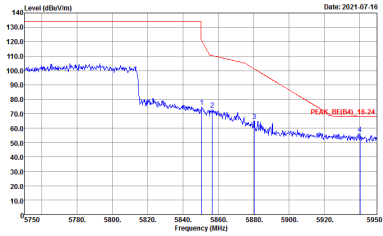

WIFI	Band 4 5725~5850MHz Band Edge @ 3m	
ANT	802.11ax HE80 Full CH155 5775MHz	
7+3	Vertical	Fundamental
Peak	 <p>Date: 2021-07-16 PEAK_BE(B4)_16-24</p> <p>Site : 03CH13-HY Condition : PEAK_BE(B4)_16-24 3m 91200-02294 VERTICAL : RBW:1000.000KHz VBW:3000.000KHz SWT:Auto</p>	 <p>Date: 2021-07-16 PEAK(B4)</p> <p>Site : 03CH13-HY Condition : PEAK(B4)_16-24 3m 91200-02294 VERTICAL : RBW:1000.000KHz VBW:3000.000KHz SWT:Auto</p>
Peak	 <p>Date: 2021-07-16 PEAK_BE(B4)_16-24</p> <p>Site : 03CH13-HY Condition : PEAK_BE(B4)_16-24 3m 91200-02294 VERTICAL : RBW:1000.000KHz VBW:3000.000KHz SWT:Auto</p>	Left blank



**Band 4 - 5725~5850MHz**

**WIFI 802.11a (Harmonic @ 3m)**

<b>WIFI</b>	<b>Band 4 5725~5850MHz Harmonic @ 3m</b>	
<b>ANT</b>	<b>802.11a CH149 5745MHz</b>	
<b>7+3</b>	<b>Horizontal</b>	<b>Vertical</b>
<b>Peak</b> <b>Avg.</b>	<p>Site : 03CH13-HY Condition : PEAK(UNIT) 3m 91200-02294 HORIZONTAL</p>	<p>Site : 03CH13-HY Condition : PEAK(UNIT) 3m 91200-02294 VERTICAL</p>



<b>WIFI</b>	<b>Band 4 5725~5850MHz Harmonic @ 3m</b>	
<b>ANT</b>	<b>802.11a CH157 5785MHz</b>	
<b>7+3</b>	<b>Horizontal</b>	<b>Vertical</b>
<b>Peak</b> <b>Avg.</b>	<p>Site : 03CH13-HY Condition : PEAK(UNIT) 3m 91200-02294 HORIZONTAL</p>	<p>Site : 03CH13-HY Condition : PEAK(UNIT) 3m 91200-02294 VERTICAL</p>



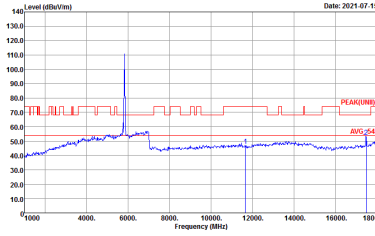
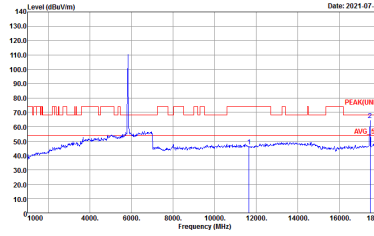

WIFI	Band 4 5725~5850MHz Harmonic @ 3m	
ANT	802.11a CH165 5825MHz	
7+3	Horizontal	Vertical
Peak Avg.	 <p>Site : 03CH13-HY Condition : PEAK(UNIT) 3m 91200-02294 HORIZONTAL</p>	 <p>Site : 03CH13-HY Condition : PEAK(UNIT) 3m 91200-02294 VERTICAL</p>



**Band 4 5725~5850MHz**  
**WIFI 802.11ax HE20 Full (Harmonic @ 3m)**

<b>WIFI</b>	<b>Band 4 5725~5850MHz Harmonic @ 3m</b>	
<b>ANT</b>	<b>802.11ax HE20 Full CH149 5745MHz</b>	
<b>7+3</b>	<b>Horizontal</b>	<b>Vertical</b>
<b>Peak</b> <b>Avg.</b>	<p>Site : 03CH13-HY          Condition : PEAQ(LINE1) 3m 91200-02294 HORIZONTAL</p>	<p>Site : 03CH13-HY          Condition : PEAQ(LINE1) 3m 91200-02294 VERTICAL</p>

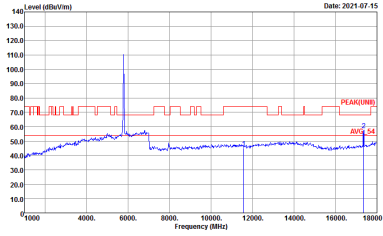
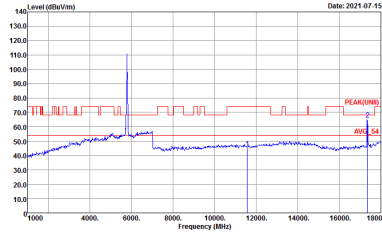

WIFI	Band 4 5725~5850MHz Harmonic @ 3m	
ANT	802.11ax HE20 Full CH157 5785MHz	
7+3	Horizontal	Vertical
Peak Avg.	 <p>Site : 03CH13-HY Condition : PEAK(UNIT) 3m 91200-02294 HORIZONTAL</p>	 <p>Site : 03CH13-HY Condition : PEAK(UNIT) 3m 91200-02294 VERTICAL</p>



<b>WIFI</b>	<b>Band 4 5725~5850MHz Harmonic @ 3m</b>	
<b>ANT</b>	<b>802.11ax HE20 Full CH165 5825MHz</b>	
<b>7+3</b>	<b>Horizontal</b>	<b>Vertical</b>
<b>Peak</b> <b>Avg.</b>	<p>Site : 03CH13-HY Condition : PEAK(UNIT) 3m 91200-02294 HORIZONTAL</p>	<p>Site : 03CH13-HY Condition : PEAK(UNIT) 3m 91200-02294 VERTICAL</p>



Band 4 5725~5850MHz
WIFI 802.11ax HE40 Full (Harmonic @ 3m)

Table with 4 columns: WIFI, ANT, 7+3, and two measurement plots (Horizontal and Vertical). The plots show Level (dBu/Vm) vs Frequency (MHz) with Peak and Avg. markers.



WIFI	Band 4 5725~5850MHz Harmonic @ 3m	
ANT	802.11ax HE40 Full CH159 5795MHz	
7+3	Horizontal	Vertical
Peak Avg.	<p>Site : 03CH13-HY Condition : PEAK(UNIT) 3m 91200-02294 HORIZONTAL</p>	<p>Site : 03CH13-HY Condition : PEAK(UNIT) 3m 91200-02294 VERTICAL</p>



**Band 4 5725~5850MHz**  
**WIFI 802.11ax HE80 Full (Harmonic @ 3m)**

<b>WIFI</b>	<b>Band 4 5725~5850MHz Harmonic @ 3m</b>	
<b>ANT</b>	<b>802.11ax HE80 Full CH155 5775MHz</b>	
<b>7+3</b>	<b>Horizontal</b>	<b>Vertical</b>
<b>Peak</b> <b>Avg.</b>	<p>Site : 03CH13-HY Condition : PEAQ(LINE1) 3m 9120D-02294 HORIZONTAL</p>	<p>Site : 03CH13-HY Condition : PEAQ(LINE1) 3m 9120D-02294 VERTICAL</p>



**Emission above 18GHz**  
**5GHz WIFI 802.11a (SHF @ 1m)**

WIFI	5GHz WIFI	
ANT	802.11a SHF	
7+3	Horizontal	Vertical
<p><b>Peak</b></p> <p><b>Avg.</b></p>	<p>Site : 03CH13-HY            Condition : PEAK(UNIT) 1m SHF_00991_210512 HORIZONTAL</p>	<p>Site : 03CH13-HY            Condition : PEAK(UNIT) 1m SHF_00991_210512 VERTICAL</p>





Emission below 1GHz  
5GHz WIFI 802.11a (LF @ 3m)

WIFI	5GHz WIFI	
ANT	802.11a LF	
7+3	Horizontal	Vertical
QP / Peak	<p>Site : 03CH13-HY Condition : QP 3m BILOG_40103 HORIZONTAL</p>	<p>Site : 03CH13-HY Condition : QP 3m BILOG_40103 VERTICAL</p>



## Appendix E. Duty Cycle Plots

Antenna	Band	Duty Cycle (%)	T(us)	1/T(kHz)	VBW Setting
7+3	802.11a	93.77	1430	0.70	1kHz
7+3	5GHz 802.11ax HE20 Full RU	96.00	2400	0.42	1kHz
7+3	5GHz 802.11ax HE40 Full RU	95.20	2380	0.42	1kHz
7+3	5GHz 802.11ax HE80 Full RU	83.88	609	1.64	3kHz

### MIMO <Ant. 7+3>

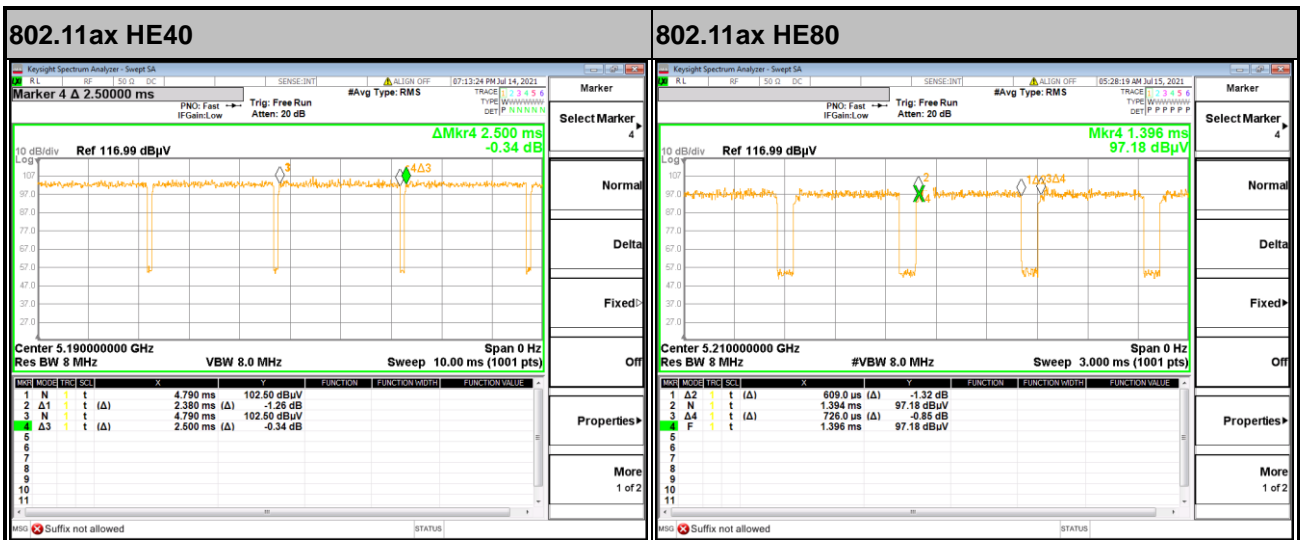
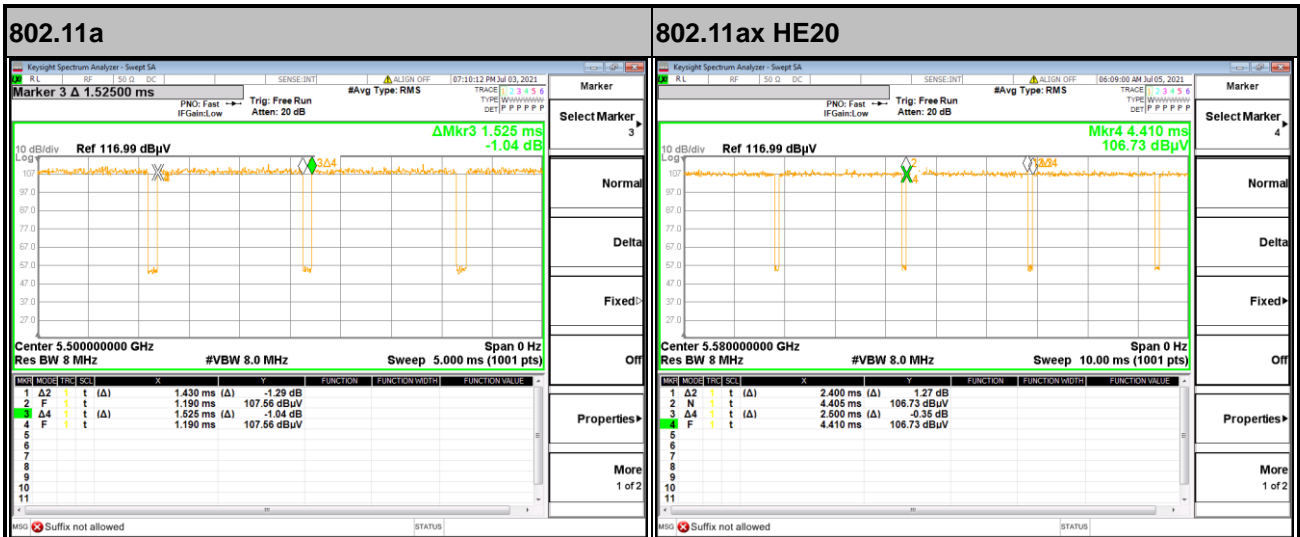

—THE END—