



# FCC CO-LOCATION RADIO TEST REPORT

**FCC ID** : A4RG6QU3  
**Equipment** : Phone  
**Model Name** : G6QU3  
**Applicant** : Google LLC  
1600 Amphitheatre Parkway,  
Mountain View, California, 94043 USA  
**Standard** : FCC Part 15 Subpart E §15.407

The product was received on Jun. 05, 2020 and testing was started from Jun. 19, 2020 and completed on Jul. 16, 2020. We, SPORTON INTERNATIONAL INC., EMC & Wireless Communications Laboratory, would like to declare that the tested sample has been evaluated in accordance with the test procedures and has been in compliance with the applicable technical standards.

The test results in this report apply exclusively to the tested model / sample. Without written approval of SPORTON INTERNATIONAL INC. EMC & Wireless Communications Laboratory, the test report shall not be reproduced except in full.

*Louis Wu*

Approved by: Louis Wu

**SPORTON INTERNATIONAL INC. EMC & Wireless Communications Laboratory**  
No. 52, Huaya 1st Rd., Guishan Dist., Taoyuan City, Taiwan (R.O.C.)



## Table of Contents

History of this test report.....	3
Summary of Test Result.....	4
<b>1 General Description .....</b>	<b>5</b>
1.1 Product Feature of Equipment Under Test.....	5
1.2 Product Specification of Equipment Under Test.....	5
1.3 Modification of EUT .....	6
1.4 Testing Location .....	6
1.5 Applicable Standards.....	6
<b>2 Test Configuration of Equipment Under Test .....</b>	<b>7</b>
2.1 Carrier Frequency and Channel .....	7
2.2 Test Mode.....	7
2.3 Connection Diagram of Test System.....	8
2.4 EUT Operation Test Setup .....	8
<b>3 Test Result .....</b>	<b>9</b>
3.1 Unwanted Emissions Measurement.....	9
3.2 Antenna Requirements.....	13
<b>4 List of Measuring Equipment.....</b>	<b>14</b>
<b>5 Uncertainty of Evaluation.....</b>	<b>15</b>
<b>Appendix A. Radiated Spurious Emission</b>	
<b>Appendix B. Radiated Spurious Emission Plots</b>	
<b>Appendix C. Duty Cycle Plots</b>	



### History of this test report

Report No.	Version	Description	Issued Date
FR050515G	01	Initial issue of report	Aug. 05, 2020



### Summary of Test Result

Report Clause	Ref Std. Clause	Test Items	Result (PASS/FAIL)	Remark
3.1	15.407(b)	Unwanted Emissions	Pass	Under limit 2.39 dB at 4960.000 MHz for Average
3.2	15.203 & 15.407 (a)	Antenna Requirement	Pass	-

<b>Declaration of Conformity:</b>
The test results with all measurement uncertainty excluded are presented in accordance with the regulation limits or requirements declared by manufacturers.
<b>Comments and Explanations:</b>
The declared of product specification for EUT presented in the report are provided by the manufacturer, and the manufacturer takes all the responsibilities for the accuracy of product specification.

Reviewed by: **Wii Chang**  
Report Producer: **Tina Chuang**



# 1 General Description

## 1.1 Product Feature of Equipment Under Test

Product Feature	
Equipment	Phone
Model Name	G6QU3
FCC ID	A4RG6QU3
EUT supports Radios application	CDMA/EV-DO/GSM/EGPRS/WCDM/HSPA/LTE/5G NR /NFC/GNSS WLAN 11b/g/n HT20 WLAN 11a/n HT20/HT40 WLAN 11ac VHT20/VHT40/VHT80 Bluetooth BR/EDR/LE

Remark: The above EUT's information was declared by manufacturer.

EUT Information List	
S/N	Performed Test Item
05281FQCB00016	Radiated Spurious Emission

## 1.2 Product Specification of Equipment Under Test

Standards-related Product Specification	
Tx/Rx Channel Frequency Range	2400 MHz ~ 2483.5 MHz 5180 MHz ~ 5240 MHz
Antenna Type / Gain	<Bluetooth> Monopole Antenna with gain 0.3 dBi <2400 MHz ~ 2483.5 MHz> <Ant. 4>: Monopole Antenna type with gain 0.3 dBi <Ant. 3>: PIFA Antenna type with gain -0.3 dBi <5180 MHz ~ 5240 MHz> <Ant. 4>: Monopole Antenna type with gain -0.9 dBi <Ant. 3>: PIFA Antenna type with gain -0.6 dBi
Type of Modulation	Bluetooth EDR (3Mbps) : 8-DPSK Bluetooth LE : GFSK 802.11b : DSSS (DBPSK / DQPSK / CCK) 802.11a : OFDM (BPSK / QPSK / 16QAM / 64QAM)



### 1.3 Modification of EUT

No modifications are made to the EUT during all test items.

### 1.4 Testing Location

<b>Test Site</b>	SPORTON INTERNATIONAL INC. EMC & Wireless Communications Laboratory
<b>Test Site Location</b>	No.58, Aly. 75, Ln. 564, Wenhua 3rd, Rd., Guishan Dist., Taoyuan City, Taiwan (R.O.C.) TEL: +886-3-327-0868 FAX: +886-3-327-0855
<b>Test Site No.</b>	<b>Sporton Site No.</b> 03CH16-HY

**Note:** The test site complies with ANSI C63.4 2014 requirement.

FCC designation No.: TW0007

### 1.5 Applicable Standards

According to the specifications of the manufacturer, the EUT must comply with the requirements of the following standards:

- ♦ FCC Part 15 Subpart E
- ♦ FCC KDB Publication No. 558074 D01 DTS Meas. Guidance v05r02
- ♦ FCC KDB 789033 D02 General UNII Test Procedures New Rules v02r01.
- ♦ FCC KDB 414788 D01 Radiated Test Site v01r01.
- ♦ FCC KDB 662911 D01 Multiple Transmitter Output v02r01.
- ♦ ANSI C63.10-2013

**Remark:**

1. All test items were verified and recorded according to the standards and without any deviation during the test.
2. The TAF code is not including all the FCC KDB listed without accreditation.
3. This EUT has also been tested and complied with the requirements of FCC Part 15, Subpart B, recorded in a separate test report.



## 2 Test Configuration of Equipment Under Test

The EUT has been associated with peripherals and configuration operated in a manner tended to maximize its emission characteristics in a typical application. Frequency range investigated: radiation emission (9 kHz to the 10th harmonic of the highest fundamental frequency or to 40 GHz, whichever is lower). For radiated measurement, pre-scanned in three orthogonal panels, X, Y, Z. The worst cases (Z plane ) were recorded in this report.

### 2.1 Carrier Frequency and Channel

2400-2483.5 MHz Bluetooth EDR		2400-2483.5 MHz Bluetooth - LE		2400-2483.5 MHz 802.11b		5150-5250 MHz 802.11a	
Channel	Freq. (MHz)	Channel	Freq. (MHz)	Channel	Freq. (MHz)	Channel	Freq. (MHz)
78	2480	39	2480	11	2462	36	5180

### 2.2 Test Mode

Final test modes are considering the modulation and worse data rates as below table.

<Co-Location>

Modulation	Data Rate
Bluetooth EDR Ant. 4 + WLAN 5GHz 802.11a for MIMO <Ant. 4 + 3>	3Mbps + 6Mbps
Bluetooth LE Ant. 4 + WLAN 5GHz 802.11a for MIMO <Ant. 4 + 3>	1Mbps + 6Mbps
WLAN 2.4GHz 802.11b Ant. 4 + WLAN 5GHz 802.11a for Ant. 3	1Mbps + 6Mbps

Remark: All the tests were performed with Adapter 1 and USB Cable 1.

## 2.3 Connection Diagram of Test System

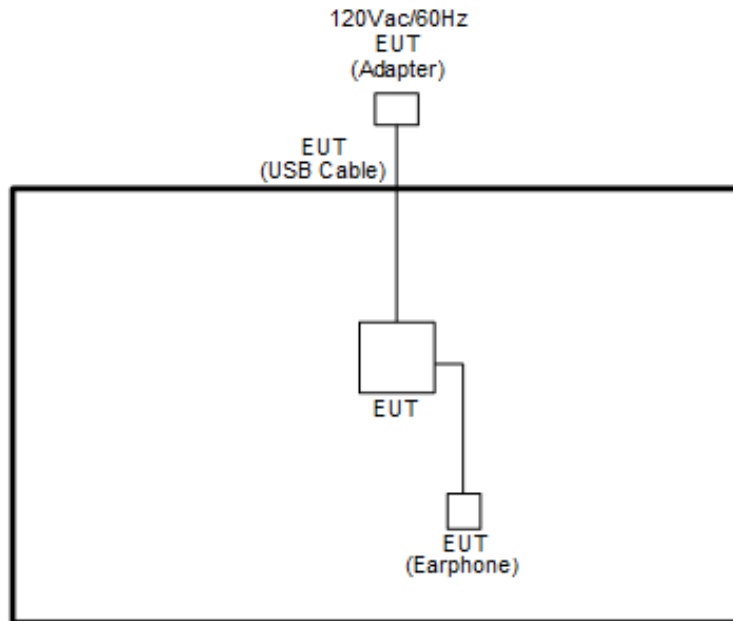

## 2.4 EUT Operation Test Setup

The RF test items, utility “QRCT v4.0.00158.0” was installed in Notebook which was programmed in order to make the EUT get into the engineering modes to provide channel selection, power level, data rate and the application type and for continuous transmitting signals.





### 3 Test Result

#### 3.1 Unwanted Emissions Measurement

This section is to measure unwanted emissions through radiated measurement for band edge spurious emissions and out of band emissions measurement.

##### 3.1.1 Limit of Unwanted Emissions

(1) Unwanted spurious emissions fallen in restricted bands shall comply with the general field strength limits as below table,

Frequency (MHz)	Field Strength (microvolts/meter)	Measurement Distance (meters)
0.009 – 0.490	2400/F(kHz)	300
0.490 – 1.705	24000/F(kHz)	30
1.705 – 30.0	30	30
30 – 88	100	3
88 – 216	150	3
216 - 960	200	3
Above 960	500	3

**Note:** The following formula is used to convert the EIRP to field strength.

$$E = \frac{1000000\sqrt{30P}}{3} \mu V/m, \text{ where } P \text{ is the eirp (Watts)}$$

EIRP (dBm)	Field Strength at 3m (dBμV/m)
- 27	68.3

(2) KDB789033 D02 v02r01 G)2)c)

- (i) Sections 15.407(b)(1-3) specifies the unwanted emissions limit for the U-NII-1 and U-NII-2 bands. As specified, emissions above 1000 MHz that are outside of the restricted bands are subject to a peak emission limit of -27 dBm/MHz.
- (ii) Section 15.407(b)(4) specifies the unwanted emissions limit for the U-NII-3 band. A band emissions mask is specified in Section 15.407(b)(4)(i). The emission limits are based on the use of a peak detector.

##### 3.1.2 Measuring Instruments

See list of measuring equipment of this test report.



### 3.1.3 Test Procedures

1. The testing follows FCC KDB 789033 D02 General UNII Test Procedures New Rules v02r01. Section G) Unwanted emissions measurement.
  - (1) Procedure for Unwanted Emissions Measurements Below 1000MHz
    - RBW = 120 kHz
    - VBW = 300 kHz
    - Detector = Peak
    - Trace mode = max hold
  - (2) Procedure for Peak Unwanted Emissions Measurements Above 1000 MHz
    - RBW = 1 MHz
    - VBW  $\geq$  3 MHz
    - Detector = Peak
    - Sweep time = auto
    - Trace mode = max hold
  - (3) Procedures for Average Unwanted Emissions Measurements Above 1000MHz
    - RBW = 1 MHz
    - VBW = 10 Hz, when duty cycle is no less than 98 percent.
    - VBW  $\geq$  1/T, when duty cycle is less than 98 percent where T is the minimum transmission duration over which the transmitter is on and is transmitting at its maximum power control level for the tested mode of operation.
2. The EUT was placed on a turntable with 0.8 meter for frequency below 1GHz and 1.5 meter for frequency above 1GHz respectively above ground.
3. The EUT was set 3 meters from the interference receiving antenna which was mounted on the top of a variable height antenna tower.
4. The antenna is a broadband antenna and its height is adjusted between one meter and four meters above ground to find the maximum value of the field strength for both horizontal polarization and vertical polarization of the antenna.
5. For each suspected emission, the EUT was arranged to its worst case and then adjust the antenna tower (from 1 m to 4 m) and turntable (from 0 degree to 360 degrees) to find the maximum reading.
6. For testing below 1GHz, if the emission level of the EUT in peak mode was 3 dB lower than the limit specified, then peak values of EUT will be reported, otherwise, the emissions will be repeated one by one using the CISPR quasi-peak method and reported.
7. For testing above 1GHz, the emission level of the EUT in peak mode was 20dB lower than average limit (that means the emission level in average mode also complies with the limit in average mode), then peak values of EUT will be reported, otherwise, the emissions will be measured in average mode again and reported.

### 3.1.4 Test Setup

For radiated emissions below 30MHz

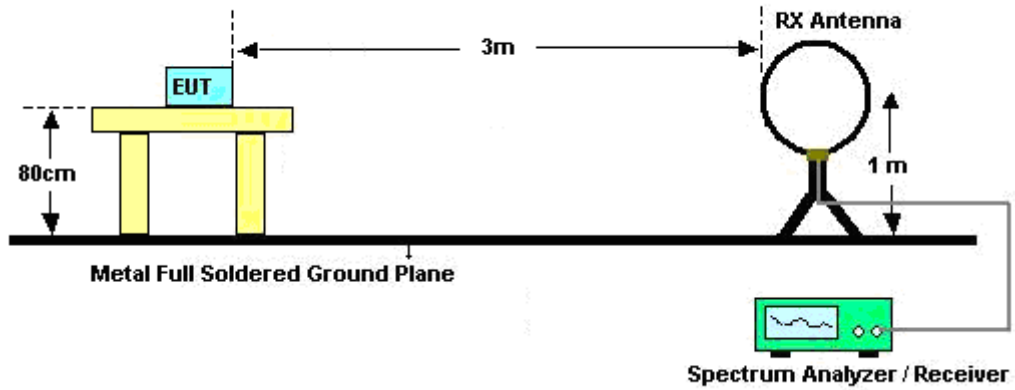

For radiated emissions from 30MHz to 1GHz

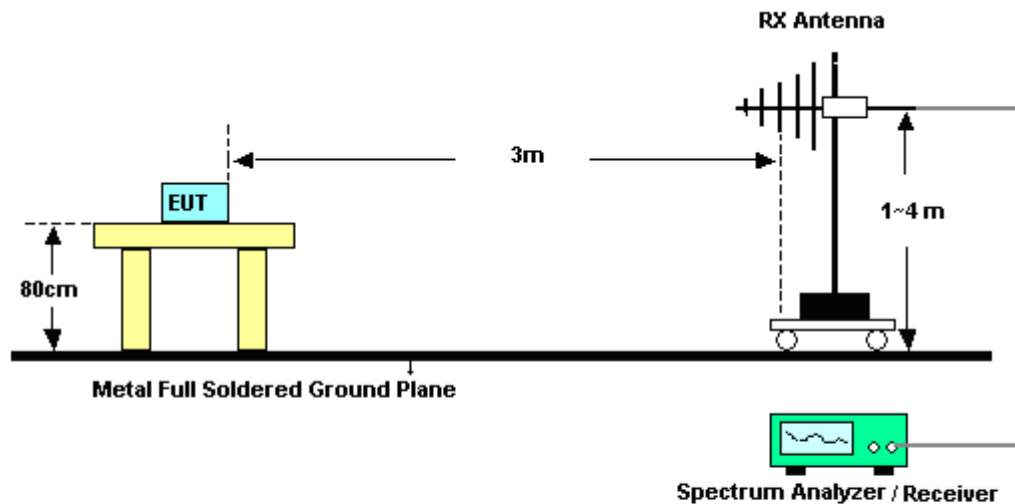

For radiated emissions above 1GHz

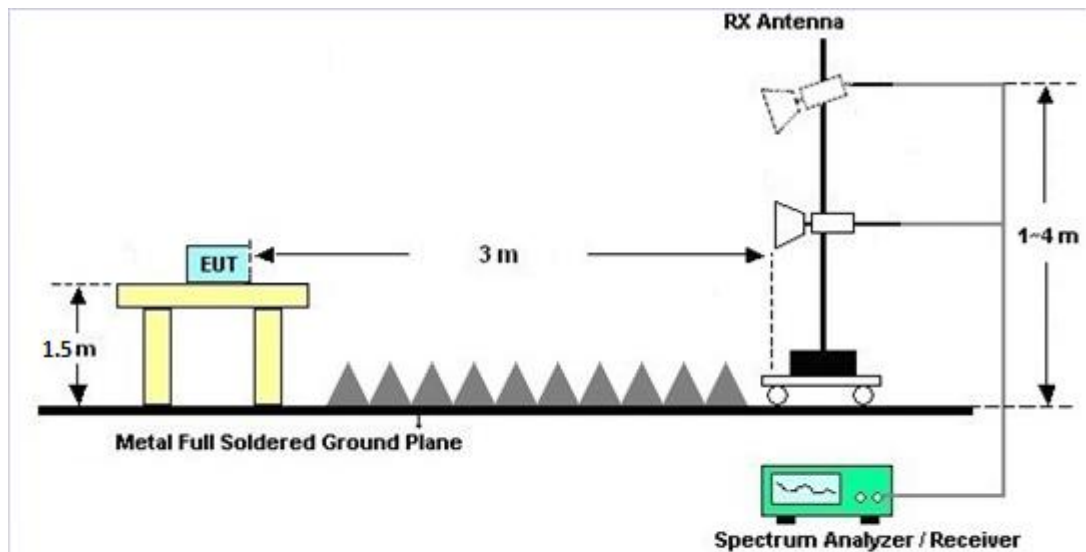

### 3.1.5 Test Results of Radiated Emissions (9 kHz ~ 30 MHz)

The low frequency, which started from 9 kHz to 30MHz, was pre-scanned and the result which was 20dB lower than the limit line was not reported.

There is a comparison data of both open-field test site and alternative test site - semi-Anechoic chamber according to 414788 D01 Radiated Test Site v01r01, and the result came out very similar.

### 3.1.6 Test Result of Radiated Band Edges

Please refer to Appendix A and B.

### 3.1.7 Duty Cycle

Please refer to Appendix C.

### 3.1.8 Test Result of Unwanted Radiated Emission (30MHz ~ 10th Harmonic)

Please refer to Appendix A and B.



## **3.2 Antenna Requirements**

### **3.2.1 Standard Applicable**

If transmitting antenna directional gain is greater than 6 dBi, both the peak transmit power and the peak power spectral density shall be reduced by the amount in dB that the directional gain of the antenna exceeds 6 dBi.

### **3.2.2 Antenna Anti-Replacement Construction**

An embedded-in antenna design is used.

### **3.2.3 Antenna Gain**

The antenna peak gain of EUT is less than 6 dBi. Therefore, it is not necessary to reduce maximum peak output power limit.



## 4 List of Measuring Equipment

Instrument	Manufacturer	Model No.	Serial No.	Characteristics	Calibration Date	Test Date	Due Date	Remark
Loop Antenna	Rohde & Schwarz	HFH2-Z2	100488	9 kHz~30 MHz	Jan. 09, 2020	Jun. 19, 2020~ Jul. 16, 2020	Jan. 08, 2021	Radiation (03CH16-HY)
Bilog Antenna	TESEQ	CBL6111D&0 0802N1D01N -06	47020&06	30MHz to 1GHz	Oct. 12, 2019	Jun. 19, 2020~ Jul. 16, 2020	Oct. 11, 2020	Radiation (03CH16-HY)
Horn Antenna	SCHWARZBE CK	BBHA 9120 D	9120D-1522	1G~18GHz	Sep. 19, 2019	Jun. 19, 2020~ Jul. 16, 2020	Sep. 18, 2020	Radiation (03CH16-HY)
SHF-EHF Horn Antenna	SCHWARZBE CK	BBHA 9170	BBHA91709 80	18GHz~40GHz	Jan.10.2020	Jun. 19, 2020~ Jul. 16, 2020	Jan.09.2021	Radiation (03CH16-HY)
Amplifier	SONOMA	310N	371607	9kHz~1G	Oct. 01. 2019	Jun. 19, 2020~ Jul. 16, 2020	Sep. 30. 2020	Radiation (03CH16-HY)
Preamplifier	Jet-Power	JPA0118-55-3 03	1710001800 055006	1GHz~18GHz	May. 07, 2020	Jun. 19, 2020~ Jul. 16, 2020	May. 06, 2021	Radiation (03CH16-HY)
Preamplifier	EMEC	EM18G40G	060715	18GHz ~40GHz	Dec. 13, 2019	Jun. 19, 2020~ Jul. 16, 2020	Dec. 12, 2020	Radiation (03CH16-HY)
Preamplifier	Keysight	83017A	MY5327026 4	1GHz~26.5GHz	Dec. 11, 2019	Jun. 19, 2020~ Jul. 16, 2020	Dec.10, 2020	Radiation (03CH16-HY)
EMI Test Receiver	Keysight	N9038A(MXE )	MY57290111	3Hz~26.5GHz	Dec. 05, 2019	Jun. 19, 2020~ Jul. 16, 2020	Dec. 04, 2020	Radiation (03CH16-HY)
RF Cable	HUBER + SUHNER	SUCOFLEX 104	MY11680/4P E	NA	Aug. 30, 2019	Jun. 19, 2020~ Jul. 16, 2020	Aug. 29, 2020	Radiation (03CH16-HY)
RF Cable	HUBER + SUHNER	SUCOFLEX 104	MY11688/4P E	NA	Aug. 30, 2019	Jun. 19, 2020~ Jul. 16, 2020	Aug. 29, 2020	Radiation (03CH16-HY)
RF Cable	HUBER + SUHNER	SUCOFLEX 102	EC-A5-300-5 757	NA	Aug. 30, 2019	Jun. 19, 2020~ Jul. 16, 2020	Aug. 29, 2020	Radiation (03CH16-HY)
Hygrometer	TECPEL	DTM-303B	TP162965	N/A	Oct 25, 2019	Jun. 19, 2020~ Jul. 16, 2020	Oct 24, 2020	Radiation (03CH16-HY)
Software	Audix	E3 6.2009-8-24	RK-001136	N/A	N/A	Jun. 19, 2020~ Jul. 16, 2020	N/A	Radiation (03CH16-HY)
Controller	ChainTek	3000-1	N/A	Control Turn table & Ant Mast	N/A	Jun. 19, 2020~ Jul. 16, 2020	N/A	Radiation (03CH16-HY)
Antenna Mast	ChainTek	MBS-520-1	N/A	1m~4m	N/A	Jun. 19, 2020~ Jul. 16, 2020	N/A	Radiation (03CH16-HY)
Turn Table	ChainTek	T-200-S-1	N/A	0~360 Degree	N/A	Jun. 19, 2020~ Jul. 16, 2020	N/A	Radiation (03CH16-HY)



## 5 Uncertainty of Evaluation

### Uncertainty of Radiated Emission Measurement (30 MHz ~ 1000 MHz)

Measuring Uncertainty for a Level of Confidence of 95% ( $U = 2Uc(y)$ )	4.9
---	-----

### Uncertainty of Radiated Emission Measurement (1000 MHz ~ 18000 MHz)

Measuring Uncertainty for a Level of Confidence of 95% ( $U = 2Uc(y)$ )	6.7
---	-----

### Uncertainty of Radiated Emission Measurement (18000 MHz ~ 40000 MHz)

Measuring Uncertainty for a Level of Confidence of 95% ( $U = 2Uc(y)$ )	3.9
---	-----



## Appendix A. Radiated Spurious Emission

Test Engineer :	Andy Yang, Karl Hou and CR Laio	Temperature :	20~25°C
		Relative Humidity :	50~65 %

2.4GHz 2400~2483.5MHz + Band 1 - 5150~5250MHz

Ant 4\_BT\_Tx\_Ch78 + Ant 4+3\_11a\_Tx\_Ch36\_Co-location (Band Edge @ 3m)

BT+WIFI Ant.	Note	Frequency ( MHz )	Level ( dBμV/m )	Over Limit ( dB )	Limit Line ( dBμV/m )	Read Level (dBμV)	Antenna Factor ( dB/m )	Path Loss ( dB )	Preamp Factor ( dB )	Ant Pos ( cm )	Table Pos ( deg )	Peak Avg. (P/A)	Pol. (H/V)	
BT CH78 2480MHz	*	2480	109.03	-	-	102.99	27.54	8.32	29.82	354	34	P	H	
	*	2480	84.24	-	-	-	-	-	-	-	-	A	H	
		2483.6	56.74	-17.26	74	50.71	27.53	8.32	29.82	354	34	P	H	
		2483.6	31.95	-22.05	54	-	-	-	-	-	-	A	H	
													H	
													H	
	*	2480	110.91	-	-	104.87	27.54	8.32	29.82	100	100	P	V	
	*	2480	86.12	-	-	-	-	-	-	-	-	-	A	V
		2483.52	59.12	-14.88	74	53.09	27.53	8.32	29.82	100	100	P	V	
		2483.52	34.33	-19.67	54	-	-	-	-	-	-	-	A	V
													V	
													V	
802.11a CH 36 5180MHz		5147.16	54.97	-19.03	74	39.79	31.71	12.32	28.85	100	118	P	H	
		5150	47.14	-6.86	54	31.97	31.7	12.32	28.85	100	118	A	H	
	*	5180	107.95	-	-	92.88	31.58	12.36	28.87	100	118	P	H	
	*	5180	100.46	-	-	85.39	31.58	12.36	28.87	100	118	A	H	
													H	
													H	
		5148.98	57.16	-16.84	74	41.99	31.7	12.32	28.85	101	262	P	V	
		5147.68	47.29	-6.71	54	32.12	31.7	12.32	28.85	101	262	A	V	
	*	5180	107.7	-	-	92.63	31.58	12.36	28.87	101	262	P	V	
	*	5180	100.55	-	-	85.48	31.58	12.36	28.87	101	262	A	V	
													V	
													V	
Remark	1. No other spurious found. 2. All results are PASS against Peak and Average limit line.													





**Ant 4\_BT\_Tx\_Ch78 + Ant 4+3\_11a\_Tx\_Ch36\_Co-location (Harmonic @ 3m)**

WIFI Ant.	Note	Frequency ( MHz )	Level ( dBμV/m )	Over Limit ( dB )	Limit Line (dBμV/m )	Read Level ( dBμV )	Antenna Factor ( dB/m )	Path Loss ( dB )	Preamp Factor ( dB )	Ant Pos ( cm )	Table Pos ( deg )	Peak Avg. (P/A)	Pol. (H/V)	
Co-location		4960	55.88	-18.12	74	39.57	31.26	13.8	28.75	100	0	P	H	
		7440	47	-27	74	52.62	36.58	16.18	58.38	100	0	P	H	
		10360	52.03	-16.17	68.2	54.12	39.64	19.17	60.9	202	344	P	H	
		15540	49.84	-24.16	74	50.23	37.94	24.38	62.71	100	0	P	H	
													H	
													H	
													H	
													H	
			4960	58.82	-15.18	74	42.51	31.26	13.8	28.75	100	0	P	V
			7440	47.41	-26.59	74	53.03	36.58	16.18	58.38	100	0	P	V
			10360	51.66	-16.54	68.2	53.75	39.64	19.17	60.9	100	326	P	V
			15540	48.82	-25.18	74	49.21	37.94	24.38	62.71	100	0	P	V
														V
														V
														V
														V
Remark	1. No other spurious found. 2. All results are PASS against Peak and Average limit line.													



**2.4GHz 2400~2483.5MHz + Band 1 - 5150~5250MHz**

**Ant 4\_BLE\_Tx\_Ch39 + Ant 4+3\_11a\_Tx\_Ch36\_Co-location (Band Edge @ 3m)**

BT+WIFI	Note	Frequency	Level	Over	Limit	Read	Antenna	Path	Preamp	Ant	Table	Peak	Pol.
Ant.		( MHz )	( dBµV/m )	( dB )	( dBµV/m )	( dBµV )	( dB/m )	( dB )	( dB )	( cm )	( deg )	( P/A )	( H/V )
BLE CH39 2480MHz	*	2480	100.53	-	-	84.57	27.54	18.24	29.82	118	115	P	H
	*	2480	99.8	-	-	83.84	27.54	18.24	29.82	118	115	A	H
		2497.76	57.37	-16.63	74	41.43	27.5	18.27	29.83	118	115	P	H
		2494.4	46.84	-7.16	54	30.9	27.51	18.26	29.83	118	115	A	H
													H
													H
	*	2480	96.55	-	-	80.59	27.54	18.24	29.82	399	80	P	V
	*	2480	95.99	-	-	80.03	27.54	18.24	29.82	399	80	A	V
		2490.6	57.22	-16.78	74	41.28	27.52	18.25	29.83	399	80	P	V
		2490.8	47.08	-6.92	54	31.13	27.52	18.26	29.83	399	80	A	V
													V
													V
802.11a CH 36 5180MHz		5148.98	55.22	-18.78	74	40.05	31.7	12.32	28.85	100	120	P	H
		5148.98	45.69	-8.31	54	30.52	31.7	12.32	28.85	100	120	A	H
	*	5180	107.66	-	-	92.59	31.58	12.36	28.87	100	120	P	H
	*	5180	100.38	-	-	85.31	31.58	12.36	28.87	100	120	A	H
													H
													H
		5149.76	54.73	-19.27	74	39.56	31.7	12.32	28.85	100	5	P	V
		5149.5	45.48	-8.52	54	30.31	31.7	12.32	28.85	100	5	A	V
	*	5180	107.59	-	-	92.52	31.58	12.36	28.87	100	5	P	V
	*	5180	100.14	-	-	85.07	31.58	12.36	28.87	100	5	A	V
													V
													V
Remark	1. No other spurious found. 2. All results are PASS against Peak and Average limit line.												



**Ant 4\_BLE\_Tx\_Ch39 + Ant 4+3\_11a\_Tx\_Ch36\_Co-location (Harmonic @ 3m)**

WIFI Ant.	Note	Frequency ( MHz )	Level ( dBμV/m )	Over Limit ( dB )	Limit Line ( dBμV/m )	Read Level ( dBμV )	Antenna Factor ( dB/m )	Path Loss ( dB )	Preamp Factor ( dB )	Ant Pos ( cm )	Table Pos ( deg )	Peak Avg. ( P/A )	Pol. ( H/V )	
Co-location		4960	59.72	-14.28	74	43.41	31.26	13.8	28.75	100	262	P	H	
		4960	51.61	-2.39	54	35.3	31.26	13.8	28.75	100	262	A	H	
		7440	48.63	-25.37	74	54.25	36.58	16.18	58.38	100	0	P	H	
		10360	51.59	-16.61	68.2	53.68	39.64	19.17	60.9	100	0	P	H	
		15540	49.93	-24.07	74	50.32	37.94	24.38	62.71	100	0	P	H	
														H
														H
														H
			4960	58.51	-15.49	74	42.2	31.26	13.8	28.75	400	76	P	V
			4960	49.96	-4.04	54	33.65	31.26	13.8	28.75	400	76	A	V
			7440	47.69	-26.31	74	53.31	36.58	16.18	58.38	100	0	P	V
			10360	51.97	-16.23	68.2	54.06	39.64	19.17	60.9	100	0	P	V
			15540	49.91	-24.09	74	50.3	37.94	24.38	62.71	100	0	P	V
														V
														V
														V
Remark	1. No other spurious found. 2. All results are PASS against Peak and Average limit line.													



2.4GHz 2400~2483.5MHz + Band 1 - 5150~5250MHz

Ant 4\_11b\_Tx\_Ch11 + Ant 3\_11a\_Tx\_Ch36\_Co-location (Band Edge @ 3m)

BT+WIFI	Note	Frequency	Level	Over	Limit	Read	Antenna	Path	Preamp	Ant	Table	Peak	Pol.
Ant.		( MHz )	( dBμV/m )	( dB )	( dBμV/m )	( dBμV )	( dB/m )	( dB )	( dB )	( cm )	( deg )	( P/A )	( H/V )
802.11b CH 11 2462MHz	*	2462	109.27	-	-	93.29	27.58	18.21	29.81	100	55	P	H
	*	2462	106.09	-	-	90.11	27.58	18.21	29.81	100	55	A	H
		2488.72	56.77	-17.23	74	40.83	27.52	18.25	29.83	100	55	P	H
		2483.52	45.33	-8.67	54	29.38	27.53	18.24	29.82	100	55	A	H
													H
													H
	*	2462	108.79	-	-	92.81	27.58	18.21	29.81	100	114	P	V
	*	2462	105.68	-	-	89.7	27.58	18.21	29.81	100	114	A	V
		2487.36	56.42	-17.58	74	40.46	27.53	18.25	29.82	100	114	P	V
		2483.52	45.19	-8.81	54	29.24	27.53	18.24	29.82	100	114	A	V
													V
													V
802.11a CH 36 5180MHz		5147.42	59.48	-14.52	74	44.3	31.71	12.32	28.85	287	23	P	H
		5149.76	49.86	-4.14	54	34.69	31.7	12.32	28.85	287	23	A	H
	*	5180	105.2	-	-	90.13	31.58	12.36	28.87	287	23	P	H
	*	5180	97.51	-	-	82.44	31.58	12.36	28.87	287	23	A	H
													H
													H
		5149.5	57.65	-16.35	74	42.48	31.7	12.32	28.85	379	96	P	V
		5149.24	49.55	-4.45	54	34.38	31.7	12.32	28.85	379	96	A	V
	*	5180	105.02	-	-	89.95	31.58	12.36	28.87	379	96	P	V
	*	5180	97.4	-	-	82.33	31.58	12.36	28.87	379	96	A	V
													V
													V
Remark	1. No other spurious found. 2. All results are PASS against Peak and Average limit line.												



**Ant 4\_11b\_Tx\_Ch11 + Ant 3\_11a\_Tx\_Ch36\_Co-location (Harmonic @ 3m)**

WIFI Ant.	Note	Frequency ( MHz )	Level ( dBμV/m )	Over Limit ( dB )	Limit Line ( dBμV/m )	Read Level ( dBμV )	Antenna Factor ( dB/m )	Path Loss ( dB )	Preamp Factor ( dB )	Ant Pos ( cm )	Table Pos ( deg )	Peak Avg. (P/A)	Pol. (H/V)	
Co-location		4924	55.84	-18.16	74	39.75	31.1	13.74	28.75	100	188	P	H	
		4924	43.82	-10.18	54	27.73	31.1	13.74	28.75	100	188	A	H	
		7386	48.1	-25.9	74	53.93	36.53	16.1	58.46	100	0	P	H	
		10360	50.47	-17.73	68.2	52.56	39.64	19.17	60.9	100	220	P	H	
		15540	49.92	-24.08	74	50.31	37.94	24.38	62.71	100	0	P	H	
														H
														H
														H
			4924	55.94	-18.06	74	39.85	31.1	13.74	28.75	100	287	P	V
			4924	44.29	-9.71	54	28.2	31.1	13.74	28.75	100	287	A	V
			7386	48.44	-25.56	74	54.27	36.53	16.1	58.46	100	0	P	V
			10360	50.63	-17.57	68.2	52.72	39.64	19.17	60.9	100	58	P	V
			15540	49.57	-24.43	74	49.96	37.94	24.38	62.71	100	0	P	V
														V
														V
														V
Remark	1. No other spurious found. 2. All results are PASS against Peak and Average limit line.													



**Note symbol**

*	<b>Fundamental Frequency</b> which can be ignored. However, the level of any unwanted emissions shall not exceed the level of the fundamental frequency.
!	Test result is <b>over limit</b> line.
P/A	<b>Peak</b> or <b>Average</b>
H/V	<b>Horizontal</b> or <b>Vertical</b>



A calculation example for radiated spurious emission is shown as below:

WIFI	Note	Frequency	Level	Over	Limit	Read	Antenna	Cable	Preamp	Ant	Table	Peak	Pol.
Ant.				Limit	Line	Level	Factor	Loss	Factor	Pos	Pos	Avg.	
1+2		( MHz )	( dBμV/m )	( dB )	( dBμV/m )	( dBμV )	( dB/m )	( dB )	( dB )	( cm )	( deg )	( P/A )	( H/V )
802.11b		2390	55.45	-18.55	74	54.51	32.22	4.58	35.86	103	308	P	H
CH 01													
2412MHz		2390	43.54	-10.46	54	42.6	32.22	4.58	35.86	103	308	A	H

- Level(dBμV/m) =  
Antenna Factor(dB/m) + Cable Loss(dB) + Read Level(dBμV) - Preamp Factor(dB)
- Over Limit(dB) = Level(dBμV/m) – Limit Line(dBμV/m)

**For Peak Limit @ 2390MHz:**

- Level(dBμV/m)  
= Antenna Factor(dB/m) + Cable Loss(dB) + Read Level(dBμV) - Preamp Factor(dB)  
= 32.22(dB/m) + 4.58(dB) + 54.51(dBμV) – 35.86 (dB)  
= 55.45 (dBμV/m)
- Over Limit(dB)  
= Level(dBμV/m) – Limit Line(dBμV/m)  
= 55.45(dBμV/m) – 74(dBμV/m)  
= -18.55(dB)

**For Average Limit @ 2390MHz:**

- Level(dBμV/m)  
= Antenna Factor(dB/m) + Cable Loss(dB) + Read Level(dBμV) - Preamp Factor(dB)  
= 32.22(dB/m) + 4.58(dB) + 42.6(dBμV) – 35.86 (dB)  
= 43.54 (dBμV/m)
- Over Limit(dB)  
= Level(dBμV/m) – Limit Line(dBμV/m)  
= 43.54(dBμV/m) – 54(dBμV/m)  
= -10.46(dB)

Both peak and average measured complies with the limit line, so test result is “PASS”.



## Appendix B. Radiated Spurious Emission Plots

Test Engineer :	Andy Yang, Karl Hou and CR Laio	Temperature :	20~25°C
		Relative Humidity :	50~65 %

### 2.4GHz 2400~2483.5MHz

### BT (Band Edge @ 3m)

BT	2.4GHz 2400~2483.5MHz Band Edge @ 3m	
ANT	BT CH78 2480MHz	
4	Horizontal	Fundamental
Peak	<p>           Site : 03CH16-HY            Condition : PEAK_BE_74 3m 91200_1522 HORIZONTAL            RBW:1000.000kHz VBW:3000.000kHz SWT:Auto            Detector : Peak            Project : 050515         </p>	<p>           Site : 03CH16-HY            Condition : PEAK_74 3m 91200_1522 HORIZONTAL            RBW:1000.000kHz VBW:3000.000kHz SWT:Auto            Detector : Peak            Project : 050515         </p>



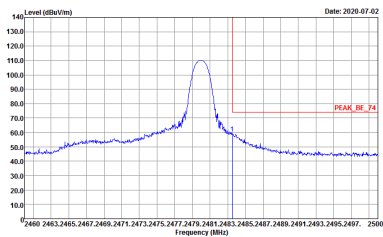
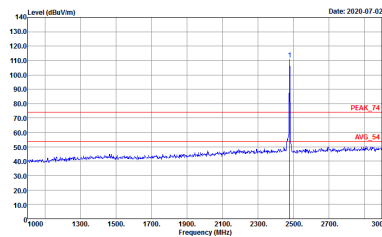

BT	2.4GHz 2400~2483.5MHz Band Edge @ 3m	
ANT	BT CH78 2480MHz	
4	Vertical	Fundamental
Peak	 <p>Site : 03CH16-11Y          Condition : PEAK_BE_74 3m 91200_1522 VERTICAL          : RBW:1000.000KHz VBW:3000.000KHz SWT:Auto          Detector : Peak          Project : 050515</p>	 <p>Site : 03CH16-11Y          Condition : PEAK_74 3m 91200_1522 VERTICAL          : RBW:1000.000KHz VBW:3000.000KHz SWT:Auto          Detector : Peak          Project : 050515</p>



**Band 1 - 5150~5250MHz**  
**WIFI 802.11a (Band Edge @ 3m)**

WIFI	Band 1 5150~5250MHz Band Edge @ 3m	
ANT	802.11a CH36 5180MHz	
4+3	Horizontal	Fundamental
<b>Peak</b>	<p>Site : 03CH16-HY            Condition : PEAK_BE_74 3m 91200_1522 HORIZONTAL            RBW:1000.000KHz VBW:3000.000KHz SWT:Auto            Detector : Peak            Project : 050515            Setting : 18</p>	<p>Site : 03CH16-HY            Condition : PEAK(FUN1) 3m 91200_1522 HORIZONTAL            RBW:1000.000KHz VBW:3000.000KHz SWT:Auto            Detector : Peak            Project : 050515            Setting : 18</p>
<b>Avg.</b>	<p>Site : 03CH16-HY            Condition : AVG_BE_54 3m 91200_1522 HORIZONTAL            RBW:1000.000KHz VBW:0.010KHz SWT:Auto            Detector : Peak            Project : 050515            Setting : 18</p>	<b>Left blank</b>

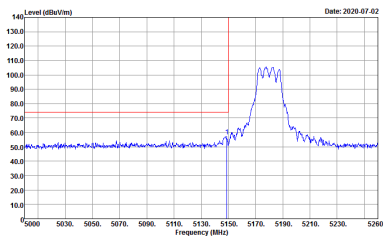
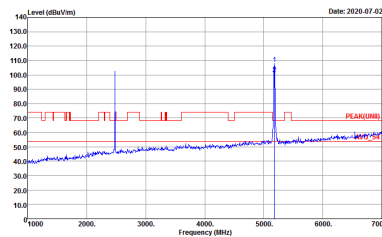
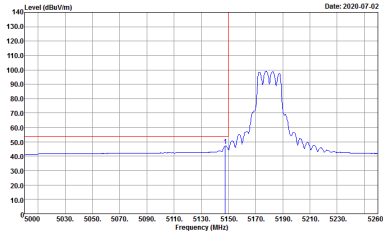

WIFI	Band 1 5150~5250MHz Band Edge @ 3m	
ANT	802.11a CH36 5180MHz	
4+3	Vertical	Fundamental
Peak	 <p>Date: 2020.07.02</p> <p>Site : 03CH16-HY            Condition : PEAK_BE_74 3m 91200_1522 VERTICAL            : RBW:1000.000KHz VBW:3000.000KHz SWT:Auto            Detector : Peak            Project : 050515            Setting : 18</p>	 <p>Date: 2020.07.02</p> <p>Site : 03CH16-HY            Condition : PEAKUNII 3m 91200_1522 VERTICAL            : RBW:1000.000KHz VBW:3000.000KHz SWT:Auto            Detector : Peak            Project : 050515            Setting : 18</p>
Avg.	 <p>Date: 2020.07.02</p> <p>Site : 03CH16-HY            Condition : AVG_BE_54 3m 91200_1522 VERTICAL            : RBW:1000.000KHz VBW:3.010KHz SWT:Auto            Detector : Peak            Project : 050515            Setting : 18</p>	Left blank

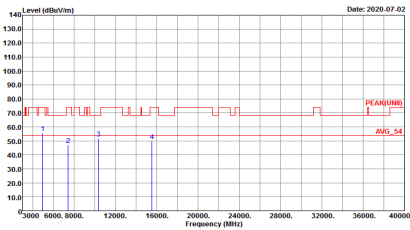
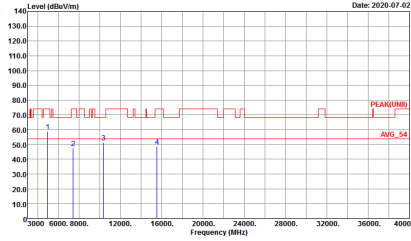

Ant 4\_BT\_Tx\_Ch78 + Ant 4+3\_11a\_Tx\_Ch36\_Co-location

Ant.	Ant 4_BT_Tx_Ch78 + Ant 4+3_11a_Tx_Ch36_Co-location	
	Horizontal	Vertical
<b>Peak</b> <b>Avg.</b>	 <p>Site : 03CH16-HY Condition : PEAK(UNII) 3m 91200_1522 HORIZONTAL Detector : Peak Project : 050515 Setting : 18</p>	 <p>Site : 03CH16-HY Condition : PEAK(UNII) 3m 91200_1522 VERTICAL Detector : Peak Project : 050515 Setting : 18</p>



2.4GHz 2400~2483.5MHz

BLE (Band Edge @ 3m)

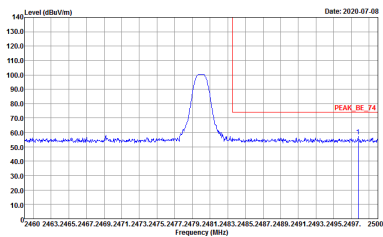
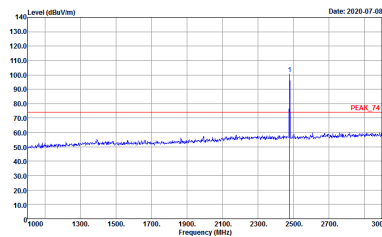
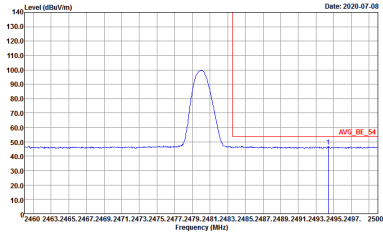
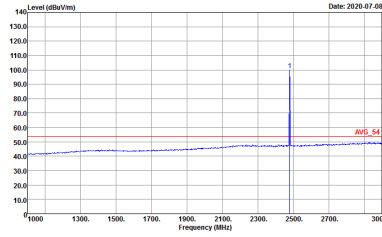
BLE	2.4GHz 2400~2483.5MHz Band Edge @ 3m	
ANT	BLE CH39 2480MHz	
4	Horizontal	Fundamental
Peak	 <p>Site : 03CH16-HY            Condition : PEAK_BE_74 3m 91200_1522 HORIZONTAL            Detector : Peak            Project : 050515</p>	 <p>Site : 03CH16-HY            Condition : PEAK_74 3m 91200_1522 HORIZONTAL            Detector : Peak            Project : 050515</p>
Avg.	 <p>Site : 03CH16-HY            Condition : AVG_BE_54 3m 91200_1522 HORIZONTAL            Detector : Peak            Project : 050515</p>	 <p>Site : 03CH16-HY            Condition : AVG_54 3m 91200_1522 HORIZONTAL            Detector : Peak            Project : 050515</p>

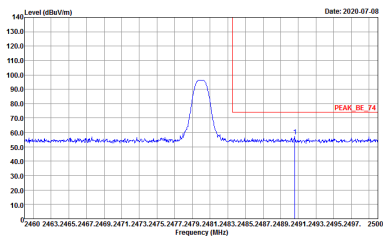
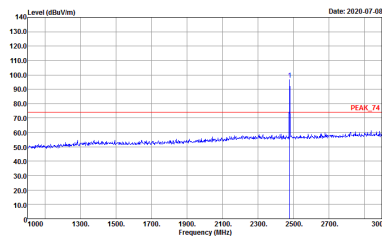
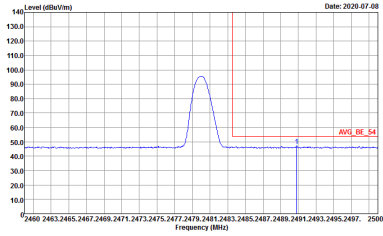
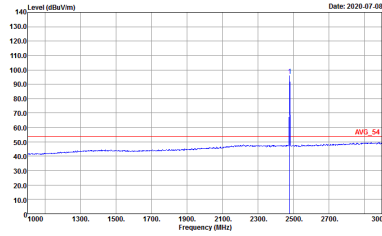

BLE	2.4GHz 2400~2483.5MHz Band Edge @ 3m	
ANT	BLE CH39 2480MHz	
4	Vertical	Fundamental
Peak	 <p>Site : 03CH16-HY            Condition : PEAK_BE_74 3m 91200_1522 VERTICAL            Detector : Peak            Project : 050515</p>	 <p>Site : 03CH16-HY            Condition : PEAK_74 3m 91200_1522 VERTICAL            Detector : Peak            Project : 050515</p>
Avg	 <p>Site : 03CH16-HY            Condition : AVG_BE_54 3m 91200_1522 VERTICAL            Detector : Peak            Project : 050515</p>	 <p>Site : 03CH16-HY            Condition : AVG_54 3m 91200_1522 VERTICAL            Detector : Peak            Project : 050515</p>



**Band 1 - 5150~5250MHz**  
**WIFI 802.11a (Band Edge @ 3m)**

WIFI	Band 1 5150~5250MHz Band Edge @ 3m	
ANT	802.11a CH36 5180MHz	
4+3	Horizontal	Fundamental
<b>Peak</b>	<p>Site : 03CH16-HY            Condition : PEAK_BE_74 3m 91200_1522 HORIZONTAL            Detector : Peak            Project : 050515</p>	<p>Site : 03CH16-HY            Condition : PEAK(FUN1) 3m 91200_1522 HORIZONTAL            Detector : Peak            Project : 050515</p>
<b>Avg.</b>	<p>Site : 03CH16-HY            Condition : AVG_BE_54 3m 91200_1522 HORIZONTAL            Detector : Peak            Project : 050515</p>	<b>Left blank</b>

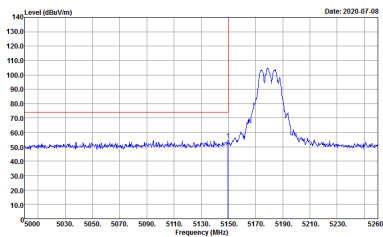
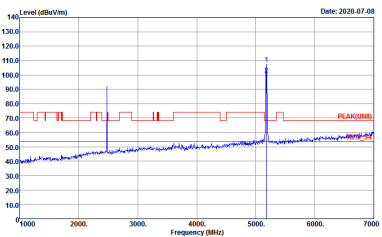
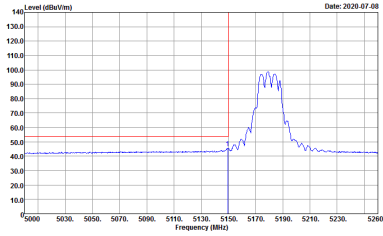

WIFI	Band 1 5150~5250MHz Band Edge @ 3m	
ANT	802.11a CH36 5180MHz	
4+3	Vertical	Fundamental
Peak	 <p>Date: 2020.07.08</p> <p>Site : 03CH16-HY          Condition : PEAK_BE_74 3m 91200_1522 VERTICAL          : RBW:1000.000kHz VBW:3000.000kHz SWT:Auto          Detector : Peak          Project : 050515</p>	 <p>Date: 2020.07.08</p> <p>Site : 03CH16-HY          Condition : PEAKUNIII 3m 91200_1522 VERTICAL          : RBW:1000.000kHz VBW:3000.000kHz SWT:Auto          Detector : Peak          Project : 050515</p>
Avg.	 <p>Date: 2020.07.08</p> <p>Site : 03CH16-HY          Condition : AVG_BE_54 3m 91200_1522 VERTICAL          : RBW:1000.000kHz VBW:1.000kHz SWT:Auto          Detector : Peak          Project : 050515</p>	Left blank



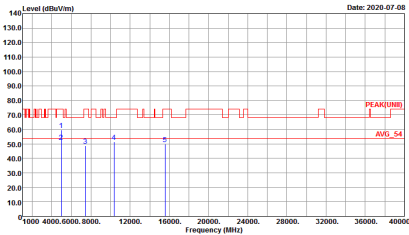
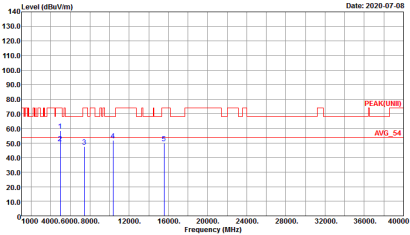

Ant 4\_BLE\_Tx\_Ch39 + Ant 4+3\_11a\_Tx\_Ch36\_Co-location

Ant.	Ant 4_BLE_Tx_Ch39 + Ant 4+3_11a_Tx_Ch36_Co-location	
	Horizontal	Vertical
<p><b>Peak</b></p> <p><b>Avg.</b></p>	 <p>Site : 03C-H16-11Y            Condition : PEAK(UNB) 3m 9120D_1522 HORIZONTAL            Detector : Peak            Project : 050515            WLAN : 11a-5            BLE : PL9 (Pmax-5)</p>	 <p>Site : 03C-H16-11Y            Condition : PEAK(UNB) 3m 9120D_1522 VERTICAL            Detector : Peak            Project : 050515            WLAN : 11a-5            BLE : PL9 (Pmax-5)</p>



2.4GHz 2400~2483.5MHz  
WIFI 802.11b (Band Edge @ 3m)

WIFI	2.4GHz 2400~2483.5MHz Band Edge @ 3m	
ANT	802.11b CH11 2462MHz	
4	Horizontal	Fundamental
Peak	<p>Site : 03CH16-HY Condition : PEAK_BE_74 3m 91200_1522 HORIZONTAL Detector : Peak Project : 050515</p>	<p>Site : 03CH16-HY Condition : PEAK_74 3m 91200_1522 HORIZONTAL Detector : Peak Project : 050515</p>
Avg.	<p>Site : 03CH16-HY Condition : AVG_BE_54 3m 91200_1522 HORIZONTAL Detector : Peak Project : 050515</p>	<p>Site : 03CH16-HY Condition : AVG_54 3m 91200_1522 HORIZONTAL Detector : Peak Project : 050515</p>

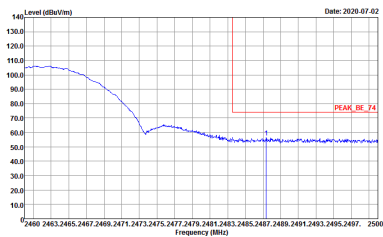
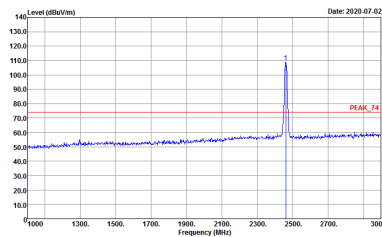
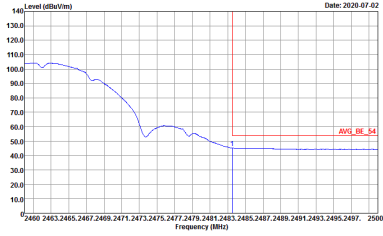
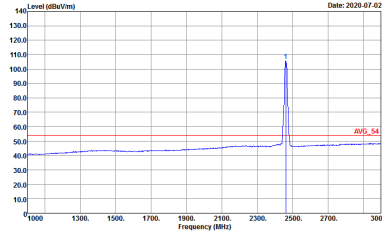

WIFI	2.4GHz 2400~2483.5MHz Band Edge @ 3m	
ANT	802.11b CH11 2462MHz	
4	Vertical	Fundamental
Peak	 <p>Site : 03CH16-HY            Condition : PEAK_BE_74 3m 91200_1522 VERTICAL            RBW:1000.000KHz VBW:3000.000KHz SWT:Auto            Detector : Peak            Project : 050515</p>	 <p>Site : 03CH16-HY            Condition : PEAK_74 3m 91200_1522 VERTICAL            RBW:1000.000KHz VBW:3000.000KHz SWT:Auto            Detector : Peak            Project : 050515</p>
Avg.	 <p>Site : 03CH16-HY            Condition : AVG_BE_54 3m 91200_1522 VERTICAL            RBW:1000.000KHz VBW:0.010KHz SWT:Auto            Detector : Peak            Project : 050515</p>	 <p>Site : 03CH16-HY            Condition : AVG_54 3m 91200_1522 VERTICAL            RBW:1000.000KHz VBW:0.010KHz SWT:Auto            Detector : Peak            Project : 050515</p>



**Band 1 - 5150~5250MHz**  
**WIFI 802.11a (Band Edge @ 3m)**

WIFI	Band 1 5150~5250MHz Band Edge @ 3m	
ANT	802.11a CH36 5180MHz	
<b>3</b>	<b>Horizontal</b>	<b>Fundamental</b>
<b>Peak</b>	<p>Site : 03CH16-HY            Condition : PEAK_BE_74 3m 9120D_1522 HORIZONTAL            RBW:1000.000KHz VBW:3000.000KHz SWT:Auto            Detector : Peak            Project : 050515</p>	<p>Site : 03CH16-HY            Condition : PEAK(FUNDE) 3m 9120D_1522 HORIZONTAL            RBW:1000.000KHz VBW:3000.000KHz SWT:Auto            Detector : Peak            Project : 050515</p>
<b>Avg.</b>	<p>Site : 03CH16-HY            Condition : AVG_BE_54 3m 9120D_1522 HORIZONTAL            RBW:1000.000KHz VBW:1.000KHz SWT:Auto            Detector : Peak            Project : 050515</p>	<b>Left blank</b>

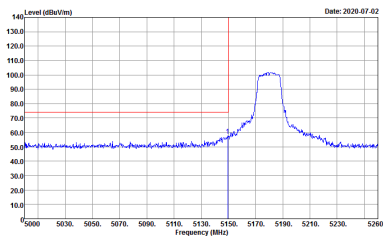
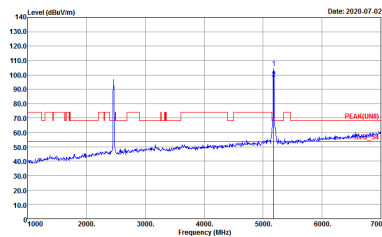
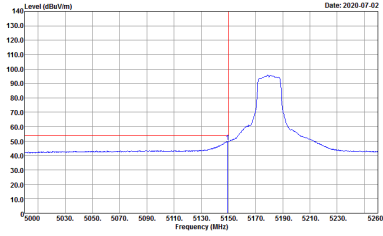

WIFI	Band 1 5150~5250MHz Band Edge @ 3m	
ANT	802.11a CH36 5180MHz	
3	Vertical	Fundamental
Peak	 <p>Site : 03CH16-HY            Condition : PEAK_BE_74 3m 91200_1522 VERTICAL            RBW:1000.000KHz VBW:3000.000KHz SWT:Auto            Detector : Peak            Project : 050515</p>	 <p>Site : 03CH16-HY            Condition : PEAK(UNII) 3m 91200_1522 VERTICAL            RBW:1000.000KHz VBW:3000.000KHz SWT:Auto            Detector : Peak            Project : 050515</p>
Avg.	 <p>Site : 03CH16-HY            Condition : AVG_BE_54 3m 91200_1522 VERTICAL            RBW:1000.000KHz VBW:1000KHz SWT:Auto            Detector : Peak            Project : 050515</p>	Left blank

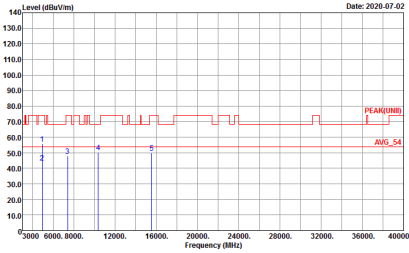
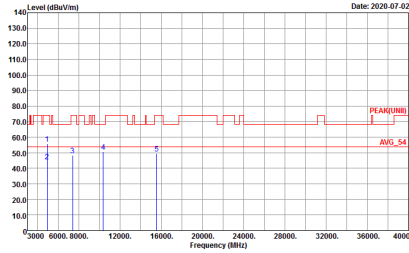

Ant 4\_11b\_Tx\_Ch11 + Ant 3\_11a\_Tx\_Ch36\_Co-location

Ant.	Ant 4_11b_Tx_Ch11 + Ant 3_11a_Tx_Ch36_Co-location	
	Horizontal	Vertical
<p><b>Peak</b></p> <p><b>Avg.</b></p>	 <p>Date: 2020-07-02</p> <p>Site : 03CH16-HY            Condition : PEAK(UNII) 3m 9120D_1522 HORIZONTAL            Detector : Peak            Project : 050515</p>	 <p>Date: 2020-07-02</p> <p>Site : 03CH16-HY            Condition : PEAK(UNII) 3m 9120D_1522 VERTICAL            Detector : Peak            Project : 050515</p>



# Appendix C. Duty Cycle Plots

### 3DH5 on time (One Pulse) Plot on Channel 39

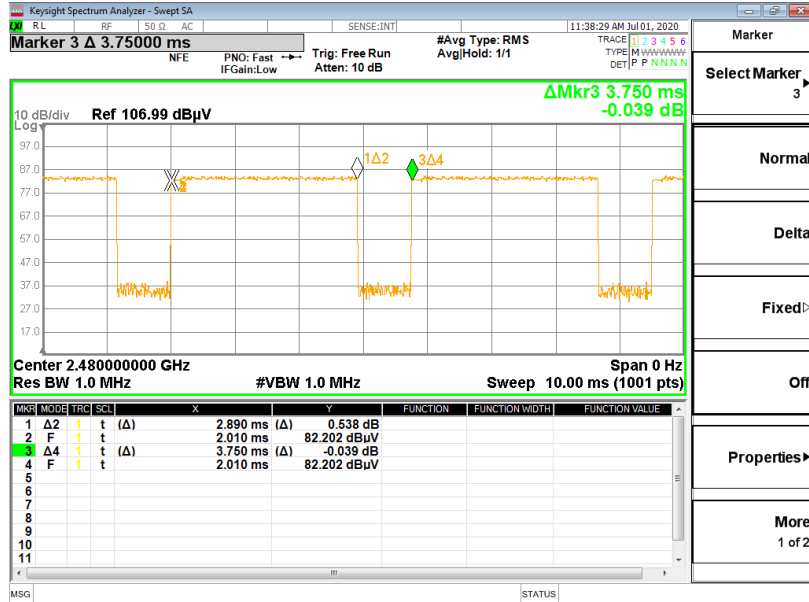

### on time (Count Pulses) Plot on Channel 39

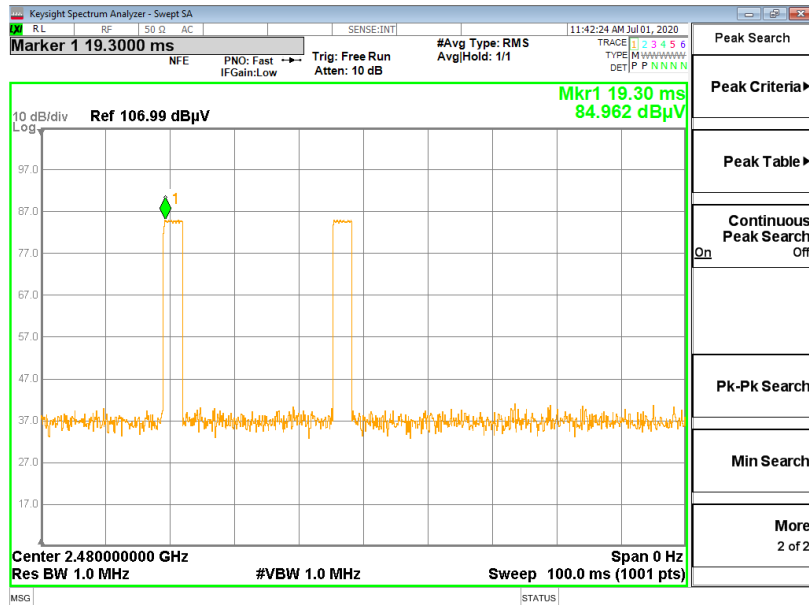

#### Note:

1. Worst case Duty cycle = on time/100 milliseconds =  $2 * 2.89 / 100 = 5.78 \%$
2. Worst case Duty cycle correction factor =  $20 * \log(\text{Duty cycle}) = -24.76 \text{ dB}$
3. 3DH5 has the highest duty cycle worst case and is reported.



**Duty Cycle Correction Factor Consideration for AFH mode:**

Bluetooth normal hopping rate is 1600Hz and reduced to 800Hz in AFH mode; due to the reduced number of hopping frequencies, with the same packet configuration the dwell time in each channel frequency within 100msec period is longer in AFH mode than normal mode.

In AFH mode, the minimum hopping frequencies are 20, to get the longest dwell time DH5 packet is observed; the period to have DH5 packet completing one hopping sequence is

$$2.89 \text{ ms} \times 20 \text{ channels} = 57.8 \text{ ms}$$

There cannot be 2 complete hopping sequences within 100ms period, considering the random hopping behavior, maximum 2 hops can be possibly observed within the period.  $[100 \text{ ms} / 57.8 \text{ ms}] = 2 \text{ hops}$

Thus, the maximum possible ON time:

$$2.89 \text{ ms} \times 2 = 5.78 \text{ ms}$$

Worst case Duty Cycle Correction factor, which is derived from the maximum possible ON time,

$$20 \times \log(5.78 \text{ ms}/100 \text{ ms}) = -24.76 \text{ dB}$$





Antenna	Band	Duty Cycle(%)	T(us)	1/T(kHz)	VBW Setting	Duty Factor(dB)
4	Bluetooth – LE for 1Mbps	63.46	396	1.60	3kHz	1.97
4	802.11b	100.00	-	-	10Hz	0.00
4+3	802.11a for Ant. 4	98.08	-	-	10Hz	0.08
4+3	802.11a for Ant. 3	98.08	-	-	10Hz	0.08

<Ant .4>

Bluetooth – LE for 1Mbps

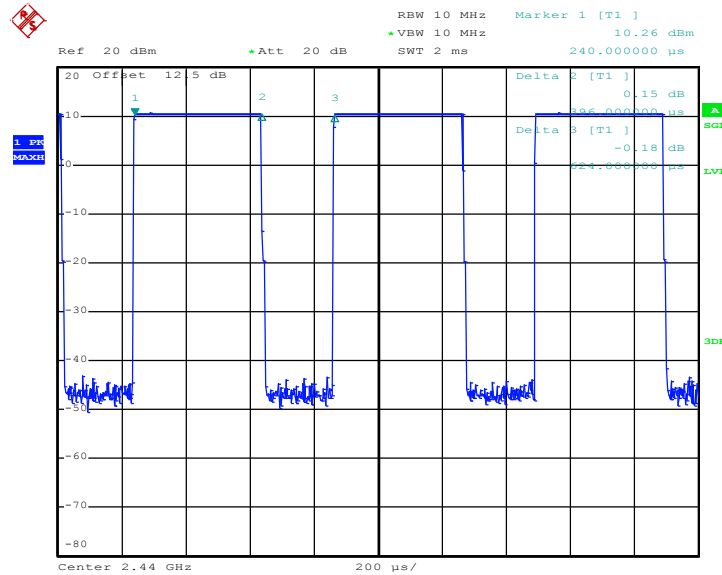

Date: 22.JUN.2020 14:28:06



802.11b

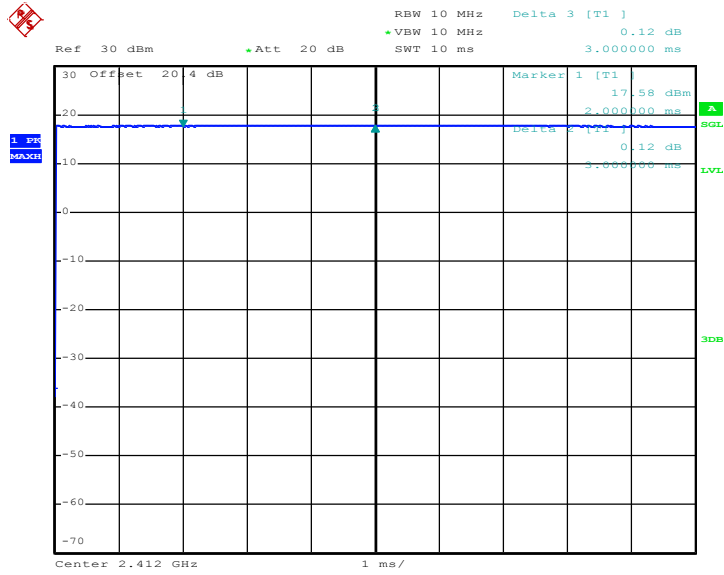

Date: 21.JUN.2020 11:10:06

MIMO <Ant. 4>

802.11a

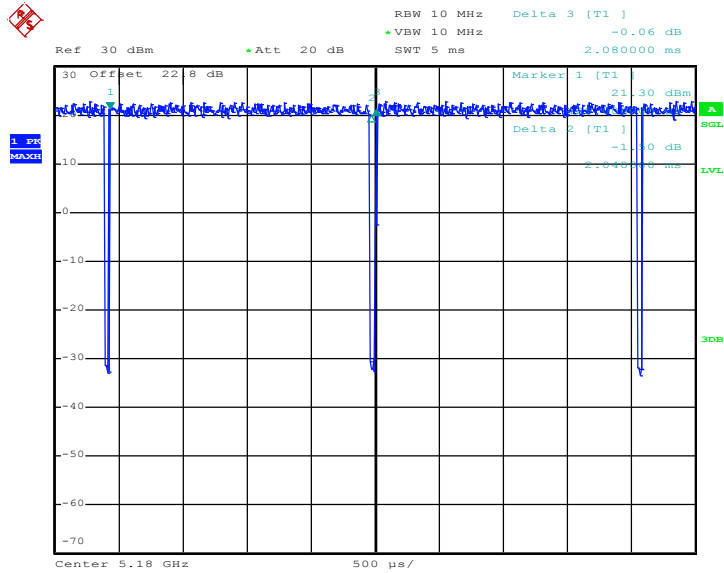

Date: 21.JUN.2020 13:10:06



MIMO <Ant. 3>

802.11a

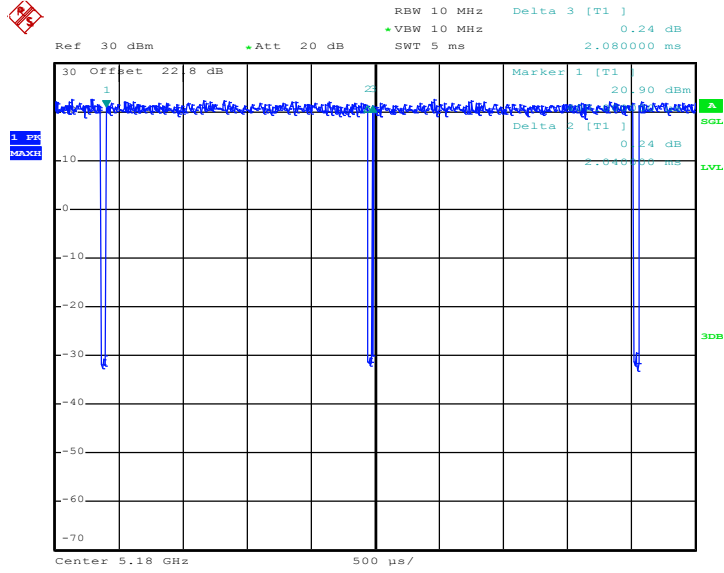

Date: 21.JUN.2020 13:11:30

—THE END—