



FCC RADIO TEST REPORT

FCC ID : A4RG025I
Equipment : Phone
Model Name : G025I, G025H
Applicant : Google LLC
1600 Amphitheatre Parkway,
Mountain View, California, 94043 USA
Standard : FCC 47 CFR Part 2, and 90(S)

The product was received on May 12, 2020 and testing was started from May 25, 2020 and completed on Jul. 01, 2020. We, SPORTON INTERNATIONAL INC. EMC & Wireless Communications Laboratory, would like to declare that the tested sample has been evaluated in accordance with the test procedures given in ANSI / TIA-603-E and has been in compliance with the applicable technical standards.

The test results in this variant report apply exclusively to the tested model / sample. Without written approval of SPORTON INTERNATIONAL INC. EMC & Wireless Communications Laboratory, the test report shall not be reproduced except in full.

Louis Wu

Approved by: Louis Wu

SPORTON INTERNATIONAL INC. EMC & Wireless Communications Laboratory
No. 52, Huaya 1st Rd., Guishan Dist., Taoyuan City, Taiwan (R.O.C.)



Table of Contents

History of this test report..... 3

Summary of Test Result..... 4

1 General Description 5

 1.1 Feature of Equipment Under Test..... 5

 1.2 Product Specification of Equipment Under Test 5

 1.3 Modification of EUT 6

 1.4 Testing Site..... 6

 1.5 Applied Standards 7

2 Test Configuration of Equipment Under Test 8

 2.1 Test Mode..... 8

 2.2 Connection Diagram of Test System 8

 2.3 Support Unit used in test configuration and system..... 9

 2.4 Frequency List of Low/Middle/High Channels..... 9

3 Conducted Test Items..... 10

 3.1 Measuring Instruments..... 10

 3.2 Conducted Output Power Measurement and ERP Measurement 11

 3.3 Field Strength of Spurious Radiation Measurement 12

4 List of Measuring Equipment..... 15

5 Uncertainty of Evaluation 16

Appendix A. Test Results of Conducted Test

Appendix B. Test Results of ERP and Radiated Test



History of this test report

Report No.	Version	Description	Issued Date
FG022521-04F	01	Initial issue of report	Jul. 09, 2020
FG022521-04F	02	Revising the remark description in summary.	Jul. 23, 2020



Summary of Test Result

Report Clause	Ref Std. Clause	Test Items	Result (PASS/FAIL)	Remark
3.2	§2.1046 §90.635	Conducted Output Power and Effective Radiated Power	Pass	-
-	-	Peak-to-Average Ratio	Not Required	-
-	§2.1049 §90.209	Occupied Bandwidth and 26dB Bandwidth	Not Required	-
-	§2.1051 §90.691	Emission masks – In-band emissions	Not Required	-
-	§2.1051 §90.691	Emission masks – Out of band emissions	Not Required	-
-	§2.1055 §90.213	Frequency Stability for Temperature & Voltage	Not Required	-
3.3	§2.1053 §90.691	Field Strength of Spurious Radiation	Pass	Under limit 36.51 dB at 2458.000 MHz for Primary Antenna Under limit 38.96 dB at 2450.000 MHz for ASDIV Antenna

Remark:

- Not required means after assessing, test items are not necessary to carry out.
- This is a variant report which can be referred Product Equality Declaration. After spot-checking the tests, the parent test results were worse than variant test results, thus this test report was reuse parent test data, all the test cases were performed on original report which can be referred to Sporton Report Number FG022521-02F.

Declaration of Conformity:

The test results with all measurement uncertainty excluded are presented in accordance with the regulation limits or requirements declared by manufacturers.

Comments and Explanations:

The declared of product specification for EUT presented in the report are provided by the manufacturer, and the manufacturer takes all the responsibilities for the accuracy of product specification.

Reviewed by: Wii Chang
Report Producer: Yimin Ho



1 General Description

1.1 Feature of Equipment Under Test

Product Feature	
Equipment	Phone
Model Name	G025I, G025H
FCC ID	A4RG025I
EUT supports Radios application	GSM/EGPRS/WCDMA/HSPA/LTE/5G NR/NFC/GNSS WLAN 11b/g/n HT20 WLAN 11a/n HT20/HT40 WLAN 11ac VHT20/VHT40/VHT80 Bluetooth BR/EDR/LE

Remark: The above EUT's information was declared by manufacturer.

EUT Information List	
S/N	Performed Test Item
04271FQCB00019	Conducted Measurement ERP
04241FQCB00338	Radiated Spurious Emission

1.2 Product Specification of Equipment Under Test

Product Specification subjective to this standard	
Tx Frequency	814.7 ~ 823.3 MHz
Rx Frequency	859.7 ~ 868.3 MHz
Bandwidth	1.4MHz / 3MHz / 5MHz / 10MHz / 15MHz
Maximum Output Power to Antenna	<Primary Antenna> 24.45 dBm <ASDIV Antenna> 24.31 dBm
Antenna Type	<Primary Antenna>: PIFA Antenna type <ASDIV Antenna>: PIFA Antenna type
Type of Modulation	QPSK / 16QAM / 64QAM

<Primary Antenna>

Radio Tech	Band Number	Antenna name	Gain
LTE	B26	Ant 0	-2.8

<ASDIV Antenna>

Radio Tech	Band Number	Antenna name	Gain
LTE	B26	Ant 1	-3.5



1.3 Modification of EUT

No modifications are made to the EUT during all test items.

1.4 Testing Site

Test Site	SPORTON INTERNATIONAL INC. EMC & Wireless Communications Laboratory
Test Site Location	No.52, Huaya 1st Rd., Guishan Dist., Taoyuan City, Taiwan (R.O.C.) TEL: +886-3-327-3456 FAX: +886-3-328-4978
Test Site No.	Sporton Site No.
	TH05-HY
Test Engineer	Luffy Lin
Temperature	22~24°C
Relative Humidity	51~55%

Note: The test site complies with ANSI C63.4 2014 requirement.

Test Site	SPORTON INTERNATIONAL INC. EMC & Wireless Communications Laboratory
Test Site Location	No.58, Aly. 75, Ln. 564, Wenhua 3rd, Rd., Guishan Dist., Taoyuan City, Taiwan (R.O.C.) TEL: +886-3-327-0868 FAX: +886-3-327-0855
Test Site No.	Sporton Site No.
	03CH12-HY
Test Engineer	Jack Cheng, Lance Chiang and Chuan Chu
Temperature	20~26°C
Relative Humidity	52~66%

Note: The test site complies with ANSI C63.4 2014 requirement.

FCC Designation No.: TW1190 and TW0007



1.5 Applied Standards

According to the specifications of the manufacturer, the EUT must comply with the requirements of the following standards:

- ♦ FCC 47 CFR Part 2, 90
- ♦ ANSI / TIA-603-E
- ♦ ANSI C63.26-2015
- ♦ FCC KDB 971168 D01 Power Meas. License Digital Systems v03r01
- ♦ FCC KDB 412172 D01 Determining ERP and EIRP v01r01
- ♦ FCC KDB 414788 D01 Radiated Test Site v01r01
- ♦ Interim Guidance for Equipment Authorization of Devices with Channel Bandwidths Combined Across Two Contiguous Service Rule Allocations OET/Lab/EACB, June 6, 2013

Remark:

1. All test items were verified and recorded according to the standards and without any deviation during the test.
2. This EUT has also been tested and complied with the requirements of FCC Part 15, Subpart B, recorded in a separate test report.
3. The TAF code is not including all the FCC KDB listed without accreditation.

2 Test Configuration of Equipment Under Test

2.1 Test Mode

During all testing, EUT is in link mode with base station emulator at maximum power level.

For radiated measurement, pre-scanned in three orthogonal panels, X, Y, Z. The worst cases (Y Plane) were recorded in this report.

Frequency range investigated for radiated emission is 30 MHz to 9000 MHz.

Conducted Test Cases	Band	Bandwidth (MHz)						Modulation			RB #			Test Channel		
		1.4	3	5	10	15	20	QPSK	16QAM	64QAM	1	Half	Full	L	M	H
Max. Output Power	26	v	v	v	v	v	-	v	v	v	v	v	v	v	v	v
E.R.P.	26					v	-	v	v	v	v			v		
Radiated Spurious Emission	26	Worst Case												v	v	
Remark	1. The mark "v " means that this configuration is chosen for testing 2. The mark "- " means that this bandwidth is not supported. 3. LTE Band26 transmit frequency for part22 rule is 824MHz-849MHz, for part90 rule is 814MHz-824MHz. ERP over 15MHz bandwidth complies the ERP limit line of part22 rule, therefore ERP of the partial frequency spectrum which falls within part 22 also complies. 4. All the radiated test cases were performed with Adapter 1 and USB Cable 1.															

2.2 Connection Diagram of Test System

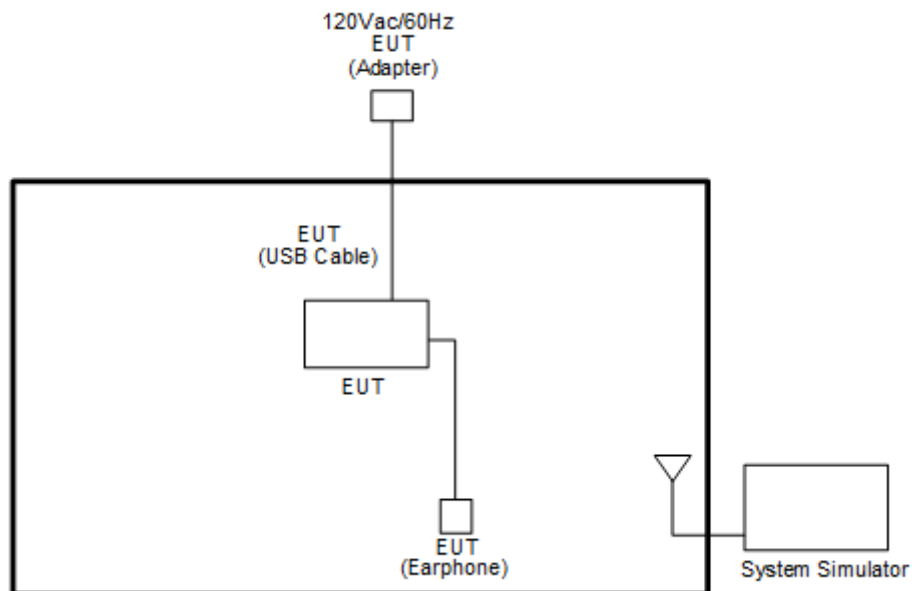



2.3 Support Unit used in test configuration and system

Item	Equipment	Trade Name	Model No.	FCC ID	Data Cable	Power Cord
1.	System Simulator	Anritsu	MT8821C	N/A	N/A	Unshielded, 1.8 m

2.4 Frequency List of Low/Middle/High Channels

LTE Band 26 Channel and Frequency List				
BW [MHz]	Channel/Frequency(MHz)	Lowest	Middle	Highest
15	Channel	26765	-	-
	Frequency	821.5	-	-
10	Channel	-	26740	-
	Frequency	-	819	-
5	Channel	26715	26740	26765
	Frequency	816.5	819	821.5
3	Channel	26705	26740	26775
	Frequency	815.5	819	822.5
1.4	Channel	26697	26740	26783
	Frequency	814.7	819	823.3

3 Conducted Test Items

3.1 Measuring Instruments

See list of measuring instruments of this test report.

3.1.1 Test Setup

3.1.2 Conducted Output Power

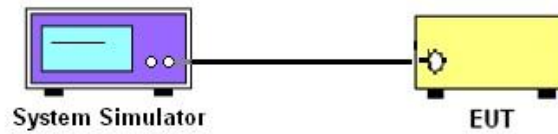

3.1.3 Test Result of Conducted Test

Please refer to Appendix A.



3.2 Conducted Output Power Measurement and ERP Measurement

3.2.1 Description of the Conducted Output Power Measurement and ERP Measurement

A system simulator was used to establish communication with the EUT. Its parameters were set to enforce EUT transmitting at the maximum power. The measured power in the radio frequency on the transmitter output terminals shall be reported.

The ERP of mobile transmitters must not exceed 7 Watts for LTE Band 26.

According to KDB 412172 D01 Power Approach,

$EIRP = P_T + G_T - L_C$, where

P_T = transmitter output power in dBm

G_T = gain of the transmitting antenna in dBi

L_C = signal attenuation in the connecting cable between the transmitter and antenna in dB

3.2.2 Test Procedures

1. The transmitter output port was connected to the system simulator.
2. Set EUT at maximum power through system simulator.
3. Select lowest, middle, and highest channels for each band and different modulation.
4. Measure and record the power level from the system simulator.



3.3 Field Strength of Spurious Radiation Measurement

3.3.1 Description of Field Strength of Spurious Radiated Measurement

The radiated spurious emission was measured by substitution method according to ANSI / TIA-603-E. The power of any emission FCC Part 90.691 on any frequency removed from the assigned frequency by more than 250 percent of the authorized bandwidth at least $43 + 10 \log (P)$ dB. The spectrum is scanned from 30 MHz up to a frequency including its 10th harmonic.

The power of any emission outside of the authorized operating frequency ranges must be attenuated below the transmitter power (P) by a factor of at least $43+10\log_{10}(P[\text{Watts}])$ dB. The spectrum is scanned from 30 MHz up to a frequency including its 10th harmonic.

3.3.2 Test Procedures

1. The EUT was placed on a turntable with 0.8 meter for frequency below 1GHz and 1.5 meter for frequency above 1GHz respectively above ground.
1. The EUT was set 3 meters from the receiving antenna, which was mounted on the antenna tower.
2. The table was rotated 360 degrees to determine the position of the highest spurious emission.
3. The height of the receiving antenna is varied between one meter and four meters to search the maximum spurious emission for both horizontal and vertical polarizations.
4. For testing below 1GHz, make the measurement with the spectrum analyzer's RBW = 100 kHz, VBW = 3MHz, Sweep = 500ms, Taking the record of maximum spurious emission.
5. For testing above 1GHz, make the measurement with the spectrum analyzer's RBW = 1MHz, VBW = 3MHz, Sweep = 500ms, Taking the record of maximum spurious emission.
6. A horn antenna was substituted in place of the EUT and was driven by a signal generator.
7. Tune the output power of signal generator to the same emission level with EUT maximum spurious emission.
8. Taking the record of output power at antenna port.
9. Repeat step 7 to step 8 for another polarization.
10. $\text{EIRP (dBm)} = \text{S.G. Power} - \text{Tx Cable Loss} + \text{Tx Antenna Gain}$
11. $\text{ERP (dBm)} = \text{EIRP} - 2.15$
12. The RF fundamental frequency should be excluded against the limit line in the operating frequency band.
13. The limit line is derived from $43 + 10\log(P)$ dB below the transmitter power P(Watts)

3.3.3 Test Setup

For radiated emissions below 30MHz

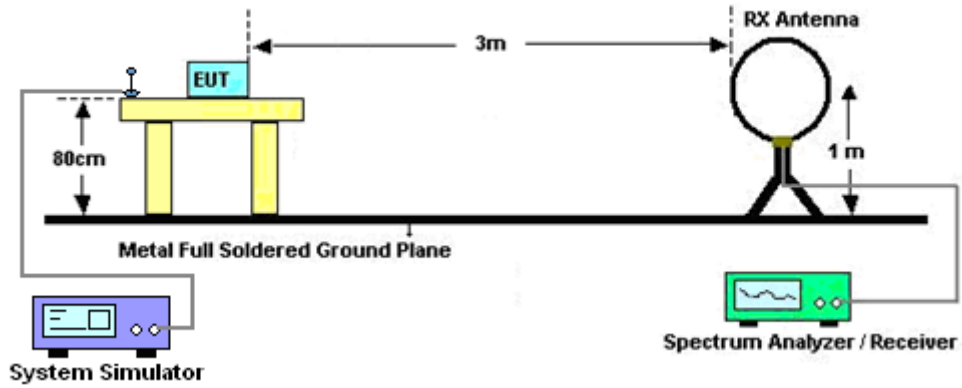

For radiated test from 30MHz to 1GHz

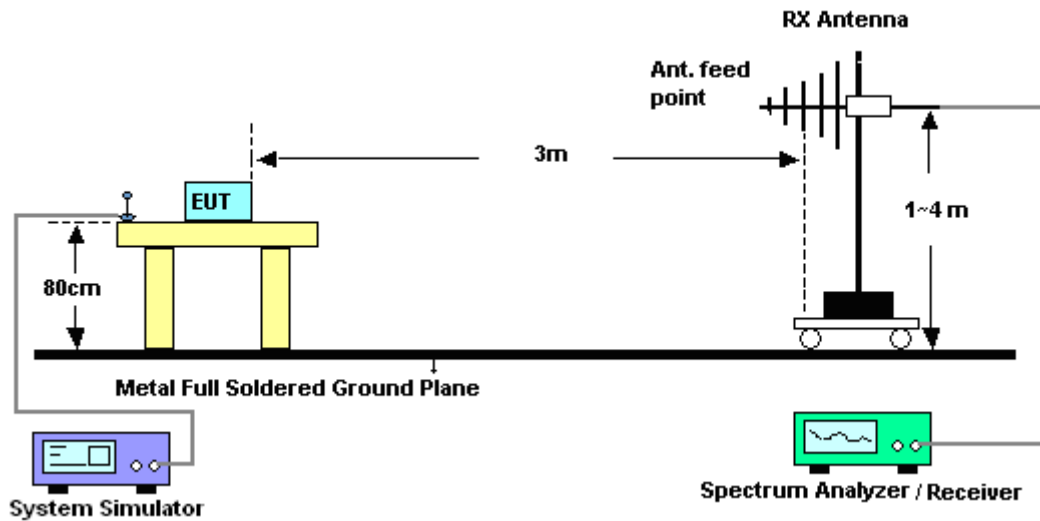

For radiated test above 1GHz

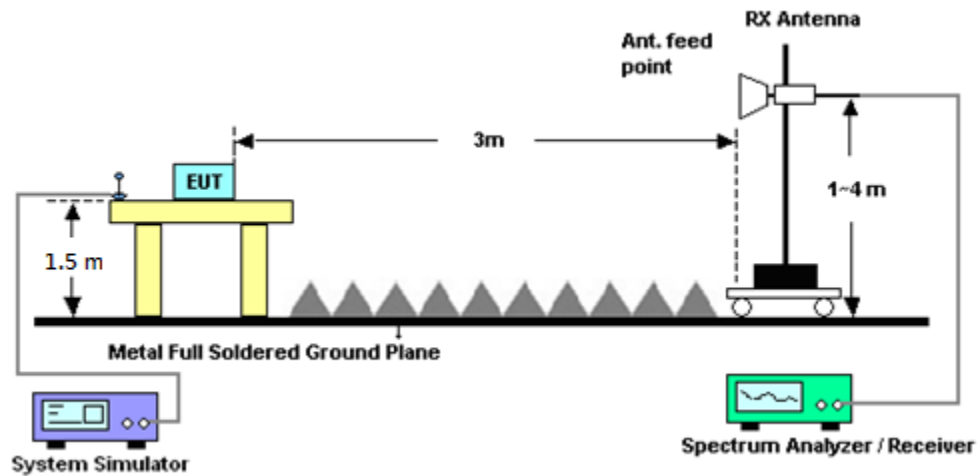

3.3.4 Test Result of Field Strength of Spurious Radiated

Please refer to Appendix B.

Note:

The low frequency, which started from 9 kHz to 30MHz, was pre-scanned and the result which was 20dB lower than the limit line was not reported.

There is a comparison data of both open-field test site and alternative test site - semi-Anechoic chamber according to 414788 D01 Radiated Test Site v01r01, and the result came out very similar.



4 List of Measuring Equipment

Instrument	Manufacturer	Model No.	Serial No.	Characteristics	Calibration Date	Test Date	Due Date	Remark
Loop Antenna	Rohde & Schwarz	HFH2-Z2	100315	9 kHz~30 MHz	Dec. 26, 2019	Jun. 23, 2020~ Jul. 01, 2020	Dec. 25, 2020	Radiation (03CH12-HY)
Bilog Antenna	TESEQ	CBL 6111D & 00800N1D01 N-06	37059 & 01	30MHz~1GHz	Oct. 12, 2019	Jun. 23, 2020~ Jul. 01, 2020	Oct. 11, 2020	Radiation (03CH12-HY)
Horn Antenna	SCHWARZBE CK	BBHA 9120D	9120D-132 8	1GHz ~ 18GHz	Nov. 14, 2019	Jun. 23, 2020~ Jul. 01, 2020	Nov. 13, 2020	Radiation (03CH12-HY)
Horn Antenna	SCHWARZBE CK	BBHA 9120D	9120D-152 2	1GHz ~ 18GHz	Sep. 19, 2019	Jun. 23, 2020~ Jul. 01, 2020	Sep. 18, 2020	Radiation (03CH12-HY)
Preamplifier	COM-POWER	PA-103	161075	10MHz~1GHz	Mar. 25, 2020	Jun. 23, 2020~ Jul. 01, 2020	Mar. 24, 2021	Radiation (03CH12-HY)
Preamplifier	Jet-Power	JPA00101800 -30-10P	160118000 2	1GHz~18GHz	Feb. 07, 2020	Jun. 23, 2020~ Jul. 01, 2020	Feb. 06, 2021	Radiation (03CH12-HY)
Preamplifier	Keysight	83017A	MY532701 48	1GHz~26.5GHz	Dec. 20, 2019	Jun. 23, 2020~ Jul. 01, 2020	Dec. 19, 2020	Radiation (03CH12-HY)
Signal Analyzer	Agilent	N9010A	MY534701 18	10Hz~44GHz	Mar. 12, 2020	Jun. 23, 2020~ Jul. 01, 2020	Mar. 11, 2021	Radiation (03CH12-HY)
Signal Generator	Rohde & Schwarz	SMB100A	101107	100kHz~40GHz	Aug. 27, 2019	Jun. 23, 2020~ Jul. 01, 2020	Aug. 26, 2020	Radiation (03CH12-HY)
Hygrometer	TECPEL	DTN-303B	TP140325	N/A	Nov. 07, 2019	Jun. 23, 2020~ Jul. 01, 2020	Nov. 06, 2020	Radiation (03CH12-HY)
RF Cable	HUBER + SUHNER	SUCOFLEX 126E	0058/126E	30M-18G	Dec. 12, 2019	Jun. 23, 2020~ Jul. 01, 2020	Dec. 11, 2020	Radiation (03CH12-HY)
Controller	EMEC	EM1000	N/A	Control Turn table & Ant Mast	N/A	Jun. 23, 2020~ Jul. 01, 2020	N/A	Radiation (03CH12-HY)
Antenna Mast	EMEC	AM-BS-4500- B	N/A	1m~4m	N/A	Jun. 23, 2020~ Jul. 01, 2020	N/A	Radiation (03CH12-HY)
Turn Table	EMEC	TT2000	N/A	0~360 Degree	N/A	Jun. 23, 2020~ Jul. 01, 2020	N/A	Radiation (03CH12-HY)
Software	Audix	E3 6.2009-8-24	RK-00098 9	N/A	N/A	Jun. 23, 2020~ Jul. 01, 2020	N/A	Radiation (03CH12-HY)
LTE Base Station	Anritsu	MT8821C	626200253 41	-	Oct. 24, 2019	May 25, 2020~ Jul. 01, 2020	Oct. 23, 2020	Conducted (TH05-HY)
Spectrum Analyzer	Rohde & Schwarz	FSV40	101397	10Hz~40GHz	Nov. 15, 2019	May 25, 2020~ Jul. 01, 2020	Nov. 14, 2020	Conducted (TH05-HY)
Temperature Chamber	ESPEC	SH-641	92013720	-40℃~90℃	Sep. 02, 2019	May 25, 2020~ Jul. 01, 2020	Sep. 01, 2020	Conducted (TH05-HY)
Programmable Power Supply	GW Instek	PSS-2005	EL890094	1V~20V 0.5A~5A	Oct. 09, 2019	May 25, 2020~ Jul. 01, 2020	Oct. 08, 2020	Conducted (TH05-HY)
Coupler	Warison	20dB 25W SMA Directional Coupler	#A	1-18GHz	Jan. 13, 2020	May 25, 2020~ Jul. 01, 2020	Jan. 12, 2021	Conducted (TH05-HY)



5 Uncertainty of Evaluation

Uncertainty of Radiated Emission Measurement (30 MHz ~ 1000 MHz)

Measuring Uncertainty for a Level of Confidence of 95% ($U = 2Uc(y)$)	3.24
---	------

Uncertainty of Radiated Emission Measurement (1 GHz ~ 18 GHz)

Measuring Uncertainty for a Level of Confidence of 95% ($U = 2Uc(y)$)	3.62
---	------



Appendix A. Test Results of Conducted Test

Conducted Output Power(Average power)

<Primary Antenna>

LTE Band 26 Maximum Average Power [dBm]						
BW [MHz]	RB Size	RB Offset	Mod	Lowest	Middle	Highest
15	1	0	QPSK	24.28	-	-
15	1	37		24.14	-	-
15	1	74		24.27	-	-
15	36	0		23.38	-	-
15	36	20		23.40	-	-
15	36	39		23.33	-	-
15	75	0		23.39	-	-
15	1	0	16-QAM	23.55	-	-
15	1	37		23.54	-	-
15	1	74		23.56	-	-
15	36	0		22.36	-	-
15	36	20		22.34	-	-
15	36	39		22.36	-	-
15	75	0		22.42	-	-
15	1	0	64-QAM	22.48	-	-
15	1	37		22.45	-	-
15	1	74		22.48	-	-
15	36	0		21.43	-	-
15	36	20		21.47	-	-
15	36	39		21.38	-	-
15	75	0		21.47	-	-
10	1	0	QPSK	-	24.29	-
10	1	25		-	24.25	-
10	1	49		-	24.29	-
10	25	0		-	23.36	-
10	25	12		-	23.41	-
10	25	25		-	23.42	-
10	50	0		-	23.41	-
10	1	0	16-QAM	-	23.60	-
10	1	25		-	23.73	-
10	1	49		-	23.67	-
10	25	0		-	22.36	-
10	25	12		-	22.42	-
10	25	25		-	22.44	-
10	50	0		-	22.37	-
10	1	0	64-QAM	-	22.51	-
10	1	25		-	22.66	-
10	1	49		-	22.60	-
10	25	0		-	21.42	-
10	25	12		-	21.47	-
10	25	25		-	21.41	-
10	50	0		-	21.37	-



LTE Band 26 Maximum Average Power [dBm]						
BW [MHz]	RB Size	RB Offset	Mod	Lowest	Middle	Highest
5	1	0	QPSK	24.45	24.32	24.35
5	1	12		24.38	24.38	24.33
5	1	24		24.30	24.37	24.26
5	12	0		23.50	23.37	23.40
5	12	7		23.51	23.41	23.44
5	12	13		23.44	23.36	23.33
5	25	0		23.44	23.40	23.38
5	1	0	16-QAM	23.78	23.60	23.73
5	1	12		23.72	23.66	23.60
5	1	24		23.66	23.72	23.58
5	12	0		22.49	22.38	22.41
5	12	7		22.45	22.45	22.41
5	12	13		22.44	22.37	22.30
5	25	0		22.43	22.39	22.40
5	1	0	64-QAM	22.73	22.56	22.53
5	1	12		22.54	22.59	21.87
5	1	24		22.56	22.57	21.82
5	12	0		21.58	21.55	21.51
5	12	7		21.59	21.50	20.86
5	12	13		21.54	21.45	20.56
5	25	0		21.50	21.39	21.08
3	1	0	QPSK	24.43	24.37	24.37
3	1	8		24.41	24.37	24.32
3	1	14		24.30	24.35	24.26
3	8	0		23.51	23.43	23.27
3	8	4		23.54	23.48	23.33
3	8	7		23.40	23.41	23.37
3	15	0		23.42	23.35	23.30
3	1	0	16-QAM	23.79	23.62	23.67
3	1	8		23.80	23.76	23.49
3	1	14		23.68	23.71	23.56
3	8	0		22.53	22.44	22.45
3	8	4		22.59	22.47	22.41
3	8	7		22.46	22.49	22.36
3	15	0		22.56	22.36	22.37
3	1	0	64-QAM	22.61	22.57	21.91
3	1	8		22.68	22.58	21.70
3	1	14		22.58	22.61	21.71
3	8	0		21.59	21.49	20.70
3	8	4		21.55	21.54	20.57
3	8	7		21.49	21.52	20.57
3	15	0		21.50	21.48	20.64



LTE Band 26 Maximum Average Power [dBm]						
BW [MHz]	RB Size	RB Offset	Mod	Lowest	Middle	Highest
1.4	1	0	QPSK	24.37	24.27	24.21
1.4	1	3		24.42	24.39	24.23
1.4	1	5		24.36	24.21	24.15
1.4	3	0		24.41	24.23	24.20
1.4	3	1		24.41	24.33	24.21
1.4	3	3		24.40	24.32	24.20
1.4	6	0		23.41	23.38	23.30
1.4	1	0	16-QAM	23.71	23.59	23.48
1.4	1	3		23.72	23.62	23.59
1.4	1	5		23.63	23.59	23.46
1.4	3	0		23.56	23.29	23.30
1.4	3	1		23.60	23.39	23.30
1.4	3	3		23.50	23.35	23.24
1.4	6	0		22.50	22.46	22.33
1.4	1	0	64-QAM	22.68	22.47	21.74
1.4	1	3		22.68	22.61	21.70
1.4	1	5		22.62	22.46	21.71
1.4	3	0		22.64	22.46	21.72
1.4	3	1		22.57	22.47	21.71
1.4	3	3		22.56	22.51	21.80
1.4	6	0		21.43	21.42	20.70



<ASDIV Antenna>

LTE Band 26 Maximum Average Power [dBm]						
BW [MHz]	RB Size	RB Offset	Mod	Lowest	Middle	Highest
15	1	0	QPSK	24.04	-	-
15	1	37		23.98	-	-
15	1	74		24.10	-	-
15	36	0		23.17	-	-
15	36	20		23.23	-	-
15	36	39		23.19	-	-
15	75	0		23.23	-	-
15	1	0	16-QAM	23.36	-	-
15	1	37		23.38	-	-
15	1	74		23.43	-	-
15	36	0		22.16	-	-
15	36	20		22.17	-	-
15	36	39		22.14	-	-
15	75	0		22.17	-	-
15	1	0	64-QAM	22.79	-	-
15	1	37		22.72	-	-
15	1	74		22.80	-	-
15	36	0		21.64	-	-
15	36	20		21.66	-	-
15	36	39		21.67	-	-
15	75	0		21.76	-	-
10	1	0	QPSK	-	24.13	-
10	1	25		-	24.13	-
10	1	49		-	24.17	-
10	25	0		-	23.12	-
10	25	12		-	23.20	-
10	25	25		-	23.23	-
10	50	0		-	23.14	-
10	1	0	16-QAM	-	23.52	-
10	1	25		-	23.51	-
10	1	49		-	23.49	-
10	25	0		-	22.20	-
10	25	12		-	22.21	-
10	25	25		-	22.23	-
10	50	0		-	22.19	-
10	1	0	64-QAM	-	22.76	-
10	1	25		-	22.91	-
10	1	49		-	22.91	-
10	25	0		-	21.73	-
10	25	12		-	21.75	-
10	25	25		-	21.75	-
10	50	0		-	21.68	-



LTE Band 26 Maximum Average Power [dBm]						
BW [MHz]	RB Size	RB Offset	Mod	Lowest	Middle	Highest
5	1	0	QPSK	24.31	24.13	24.11
5	1	12		24.24	24.19	24.09
5	1	24		24.07	24.24	24.16
5	12	0		23.33	23.23	23.21
5	12	7		23.27	23.27	23.22
5	12	13		23.26	23.24	23.11
5	25	0		23.28	23.13	23.20
5	1	0	16-QAM	23.63	23.43	23.45
5	1	12		23.43	23.51	23.32
5	1	24		23.44	23.49	23.31
5	12	0		22.38	22.22	22.22
5	12	7		22.32	22.24	22.21
5	12	13		22.21	22.25	22.18
5	25	0		22.22	22.21	22.21
5	1	0	64-QAM	23.02	22.85	22.89
5	1	12		22.84	22.89	22.19
5	1	24		22.68	22.92	22.34
5	12	0		21.90	21.84	21.65
5	12	7		21.89	21.81	21.18
5	12	13		21.75	21.82	21.02
5	25	0		21.82	21.68	21.36
3	1	0	QPSK	24.19	24.16	24.20
3	1	8		24.24	24.27	24.13
3	1	14		24.07	24.18	24.11
3	8	0		23.34	23.18	23.17
3	8	4		23.25	23.25	23.22
3	8	7		23.29	23.24	23.10
3	15	0		23.24	23.18	23.13
3	1	0	16-QAM	23.53	23.45	23.50
3	1	8		23.59	23.51	23.39
3	1	14		23.50	23.53	23.35
3	8	0		22.35	22.23	22.26
3	8	4		22.30	22.37	22.25
3	8	7		22.27	22.33	22.13
3	15	0		22.38	22.17	22.16
3	1	0	64-QAM	22.92	22.87	22.25
3	1	8		23.00	22.93	22.12
3	1	14		22.86	22.84	22.30
3	8	0		21.87	21.79	21.08
3	8	4		21.84	21.88	21.07
3	8	7		21.88	21.80	21.14
3	15	0		21.81	21.79	21.12



LTE Band 26 Maximum Average Power [dBm]						
BW [MHz]	RB Size	RB Offset	Mod	Lowest	Middle	Highest
1.4	1	0	QPSK	24.16	24.04	24.05
1.4	1	3		24.24	24.13	24.07
1.4	1	5		24.12	24.08	23.93
1.4	3	0		24.23	24.06	24.02
1.4	3	1		24.21	24.05	24.03
1.4	3	3		24.16	24.14	23.99
1.4	6	0		23.25	23.20	23.04
1.4	1	0	16-QAM	23.52	23.37	23.36
1.4	1	3		23.54	23.47	23.35
1.4	1	5		23.41	23.39	23.29
1.4	3	0		23.23	23.16	23.12
1.4	3	1		23.23	23.20	23.14
1.4	3	3		23.27	23.11	23.09
1.4	6	0		22.34	22.26	22.14
1.4	1	0	64-QAM	22.85	22.81	22.16
1.4	1	3		22.96	22.89	22.39
1.4	1	5		22.79	22.75	22.41
1.4	3	0		22.92	22.75	22.11
1.4	3	1		22.90	22.81	22.20
1.4	3	3		22.84	22.75	22.38
1.4	6	0		21.75	21.73	21.14



Appendix B. Test Results of ERP and Radiated Test

ERP

<Primary Antenna>

LTE Band 26 / 15MHz (Channel 26765) (GT - LC = -2.8 dB)							
Channel	Mode	RB		Conducted		ERP	
		Size	Offset	Power (dBm)	Power (Watts)	ERP(dBm)	ERP(W)
Lowest	QPSK	1	0	24.28	0.2679	19.33	0.0857
Middle		-	-	-	-	-	-
Highest		-	-	-	-	-	-
Lowest	16QAM	1	74	23.56	0.2270	18.61	0.0726
Middle		-	-	-	-	-	-
Highest		-	-	-	-	-	-
Lowest	64QAM	1	0	22.48	0.1770	17.53	0.0566
Middle		-	-	-	-	-	-
Highest		-	-	-	-	-	-



<ASDIV Antenna>

LTE Band 26 / 15MHz (Channel 26765) (GT - LC = -3.5 dB)							
Channel	Mode	RB		Conducted		ERP	
		Size	Offset	Power (dBm)	Power (Watts)	ERP(dBm)	ERP(W)
Lowest	QPSK	1	74	24.10	0.2570	18.45	0.0700
Middle		-	-	-	-	-	-
Highest		-	-	-	-	-	-
Lowest	16QAM	1	74	23.43	0.2203	17.78	0.0600
Middle		-	-	-	-	-	-
Highest		-	-	-	-	-	-
Lowest	64QAM	1	74	22.80	0.1905	17.15	0.0519
Middle		-	-	-	-	-	-
Highest		-	-	-	-	-	-



Radiated Spurious Emission

<Primary Antenna>

<Ant. 0>

LTE Band 26

LTE Band 26 / 5MHz / QPSK									
Channel	Frequency (MHz)	ERP (dBm)	Limit (dBm)	Over Limit (dB)	SPA Reading (dBm)	S.G. Power (dBm)	TX Cable loss (dB)	TX Antenna Gain (dBi)	Polarization (H/V)
Highest	1638	-61.10	-13	-48.10	-70.74	-66.66	0.92	8.62	H
	2458	-51.05	-13	-38.05	-64.91	-58.40	1.14	10.64	H
	3277	-55.42	-13	-42.42	-70.89	-63.91	1.32	11.96	H
									H
									H
									H
									H
	1638	-61.82	-13	-48.82	-70.97	-67.38	0.92	8.62	V
	2458	-49.51	-13	-36.51	-63.48	-56.86	1.14	10.64	V
	3277	-54.92	-13	-41.92	-70.87	-63.41	1.32	11.96	V
									V
									V
									V
									V

Remark: Spurious emissions within 30-1000MHz were found more than 20dB below limit line.



<ASDIV Antenna>

<Ant. 1>

LTE Band 26

LTE Band 26 / 5MHz / QPSK									
Channel	Frequency (MHz)	ERP (dBm)	Limit (dBm)	Over Limit (dB)	SPA Reading (dBm)	S.G. Power (dBm)	TX Cable loss (dB)	TX Antenna Gain (dBi)	Polarization (H/V)
Middle	1633	-61.11	-13	-48.11	-70.74	-66.65	0.92	8.61	H
	2450	-51.96	-13	-38.96	-65.81	-59.30	1.14	10.63	H
	3267	-55.55	-13	-42.55	-71.04	-64.02	1.32	11.94	H
									H
									H
									H
									H
	1633	-58.81	-13	-45.81	-67.97	-64.35	0.92	8.61	V
	2450	-54.63	-13	-41.63	-68.58	-61.97	1.14	10.63	V
	3267	-55.32	-13	-42.32	-71.29	-63.79	1.32	11.94	V
									V
									V
									V
									V

Remark: Spurious emissions within 30-1000MHz were found more than 20dB below limit line.

————THE END————