



FCC RADIO TEST REPORT

FCC ID : A4RG025E
Equipment : Phone
Model Name : G025E
Applicant : Google LLC
1600 Amphitheatre Parkway,
Mountain View, California, 94043 USA
Standard : FCC Part 15 Subpart E §15.407

The product was received on Apr. 30, 2020 and testing was started from May 08, 2020 and completed on Jun. 19, 2020. We, SPORTON INTERNATIONAL INC., EMC & Wireless Communications Laboratory, would like to declare that the tested sample has been evaluated in accordance with the test procedures and has been in compliance with the applicable technical standards.

The test results in this report apply exclusively to the tested model / sample. Without written approval of SPORTON INTERNATIONAL INC. EMC & Wireless Communications Laboratory, the test report shall not be reproduced except in full.

Louis Wu

Approved by: Louis Wu

SPORTON INTERNATIONAL INC. EMC & Wireless Communications Laboratory
No. 52, Huaya 1st Rd., Guishan Dist., Taoyuan City, Taiwan (R.O.C.)



Table of Contents

History of this test report.....	3
Summary of Test Result.....	4
1 General Description	5
1.1 Product Feature of Equipment Under Test.....	5
1.2 Product Specification of Equipment Under Test.....	6
1.3 Modification of EUT	7
1.4 Testing Location	7
1.5 Applicable Standards.....	7
2 Test Configuration of Equipment Under Test	8
2.1 Carrier Frequency and Channel	8
2.2 Test Mode.....	9
2.3 Connection Diagram of Test System.....	10
2.4 Support Unit used in test configuration and system	11
2.5 EUT Operation Test Setup	11
2.6 Measurement Results Explanation Example.....	11
3 Test Result	12
3.1 6dB and 26dB and 99% Occupied Bandwidth Measurement	12
3.2 Maximum Conducted Output Power Measurement	15
3.3 Power Spectral Density Measurement	16
3.4 Unwanted Emissions Measurement.....	19
3.5 AC Conducted Emission Measurement.....	24
3.6 Automatically Discontinue Transmission	26
3.7 Antenna Requirements.....	28
4 List of Measuring Equipment.....	29
5 Uncertainty of Evaluation.....	31
Appendix A. Conducted Test Results	
Appendix B. AC Conducted Emission Test Result	
Appendix C. Radiated Spurious Emission	
Appendix D. Radiated Spurious Emission Plots	
Appendix E. Duty Cycle Plots	



History of this test report

Report No.	Version	Description	Issued Date
FR022521-02F	01	Initial issue of report	Jun. 26, 2020



Summary of Test Result

Report Clause	Ref Std. Clause	Test Items	Result (PASS/FAIL)	Remark
3.1	15.403 (i)	6dB & 26dB Bandwidth	Pass	-
3.1	2.1049	99% Occupied Bandwidth	Reporting only	-
3.2	15.407 (a)	Maximum Conducted Output Power	Pass	-
3.3	15.407 (a)	Power Spectral Density	Pass	-
3.4	15.407(b)	Unwanted Emissions	Pass	Under limit 4.34 dB at 11570.000 MHz
3.5	15.207	AC Conducted Emission	Pass	Under limit 6.08 dB at 0.755 MHz
3.6	15.407 (c)	Automatically Discontinue Transmission	Pass	-
3.7	15.203 & 15.407 (a)	Antenna Requirement	Pass	-

Declaration of Conformity:

The test results with all measurement uncertainty excluded are presented in accordance with the regulation limits or requirements declared by manufacturers.

Comments and Explanations:

The declared of product specification for EUT presented in the report are provided by the manufacturer, and the manufacturer takes all the responsibilities for the accuracy of product specification.

Reviewed by: Wii Chang

Report Producer: Yimin Ho



1 General Description

1.1 Product Feature of Equipment Under Test

Product Feature	
Equipment	Phone
Model Name	G025E
FCC ID	A4RG025E
EUT supports Radios application	CDMA/EV-DO/GSM/EGPRS/WCDMA/HSPA/LTE/5G NR/ NFC/GNSS WLAN 11b/g/n HT20 WLAN 11a/n HT20/HT40 WLAN 11ac VHT20/VHT40/VHT80 Bluetooth BR/EDR/LE

Remark: The above EUT's information was declared by manufacturer.

EUT Information List	
S/N	Performed Test Item
04211FQCB00023	RF Conducted Measurement
04241FQCB00323	Radiated Spurious Emission
04241FQCB00291	Conducted Emission



1.2 Product Specification of Equipment Under Test

Standards-related Product Specification										
Tx/Rx Channel Frequency Range	5745 MHz ~ 5825 MHz									
Maximum Output Power	<p><Ant. 4> 802.11a : 18.30 dBm / 0.0676 W 802.11n HT20 : 18.30 dBm / 0.0676 W 802.11n HT40 : 17.30 dBm / 0.0537 W 802.11ac VHT20: 18.20 dBm / 0.0661 W 802.11ac VHT40: 17.20 dBm / 0.0525 W 802.11ac VHT80: 16.80 dBm / 0.0479 W.</p> <p><Ant. 3> 802.11a : 17.80 dBm / 0.0603 W 802.11n HT20 : 17.80 dBm / 0.0603 W 802.11n HT40 : 17.00 dBm / 0.0501 W 802.11ac VHT20: 17.70 dBm / 0.0589 W 802.11ac VHT40: 16.90 dBm / 0.0490 W 802.11ac VHT80: 16.10 dBm / 0.0407 W</p> <p>MIMO <Ant. 4 + 3> 802.11a : 21.17 dBm / 0.1309 W 802.11n HT20 : 21.12 dBm / 0.1294 W 802.11n HT40 : 20.26 dBm / 0.1062 W 802.11ac VHT20: 21.02 dBm / 0.1265 W 802.11ac VHT40: 20.16 dBm / 0.1038 W 802.11ac VHT80: 19.57 dBm / 0.0906 W</p>									
99% Occupied Bandwidth	<p>MIMO <Ant. 4> 802.11a : 17.00 MHz 802.11n HT20 : 18.05 MHz 802.11n HT40 : 36.80 MHz 802.11ac VHT80 : 76.56 MHz</p> <p>MIMO <Ant. 3> 802.11a : 17.00 MHz 802.11n HT20 : 18.20 MHz 802.11n HT40 : 36.70 MHz 802.11ac VHT80 : 76.68 MHz</p>									
Type of Modulation	802.11a/n : OFDM (BPSK / QPSK / 16QAM / 64QAM) 802.11ac : OFDM (BPSK / QPSK / 16QAM / 64QAM / 256QAM)									
Antenna Type / Gain	<p><Ant. 4> : Monopole Antenna with gain -1.80 dBi <Ant. 3> : PIFA Antenna with gain -0.50 dBi</p>									
Antenna Function Description	<table border="1"> <thead> <tr> <th></th> <th>Ant. 4</th> <th>Ant. 3</th> </tr> </thead> <tbody> <tr> <td>802.11 a/n/ac</td> <td>V</td> <td>V</td> </tr> <tr> <td>802.11 a/n/ac MIMO</td> <td>V</td> <td>V</td> </tr> </tbody> </table>		Ant. 4	Ant. 3	802.11 a/n/ac	V	V	802.11 a/n/ac MIMO	V	V
	Ant. 4	Ant. 3								
802.11 a/n/ac	V	V								
802.11 a/n/ac MIMO	V	V								

Remark: MIMO Ant. 4+3 is a calculated result from sum of the power MIMO Ant. 4 and MIMO Ant. 3.



1.3 Modification of EUT

No modifications are made to the EUT during all test items.

1.4 Testing Location

Test Site	SPORTON INTERNATIONAL INC. EMC & Wireless Communications Laboratory		
Test Site Location	No.52, Huaya 1st Rd., Guishan Dist., Taoyuan City, Taiwan (R.O.C.) TEL: +886-3-327-3456 FAX: +886-3-328-4978		
Test Site No.	Sporton Site No.		
	TH05-HY	CO05-HY	03CH07-HY

Note: The test site complies with ANSI C63.4 2014 requirement.

FCC designation No.: TW1190

1.5 Applicable Standards

According to the specifications of the manufacturer, the EUT must comply with the requirements of the following standards:

- ♦ FCC Part 15 Subpart E
- ♦ FCC KDB 789033 D02 General UNII Test Procedures New Rules v02r01.
- ♦ FCC KDB 414788 D01 Radiated Test Site v01r01.
- ♦ FCC KDB 662911 D01 Multiple Transmitter Output v02r01.
- ♦ ANSI C63.10-2013

Remark:

1. All test items were verified and recorded according to the standards and without any deviation during the test.
2. The TAF code is not including all the FCC KDB listed without accreditation.
3. This EUT has also been tested and complied with the requirements of FCC Part 15, Subpart B, recorded in a separate test report.



2 Test Configuration of Equipment Under Test

- a. The EUT has been associated with peripherals and configuration operated in a manner tended to maximize its emission characteristics in a typical application. Frequency range investigated: conduction emission (150 kHz to 30 MHz), radiation emission (9 kHz to the 10th harmonic of the highest fundamental frequency or to 40 GHz, whichever is lower). For radiated measurement, pre-scanned in three orthogonal panels, X, Y, Z. The worst cases (X plane) were recorded in this report.

- b. AC power line Conducted Emission was tested under maximum output power.

2.1 Carrier Frequency and Channel

Frequency Band	Channel	Freq. (MHz)	Channel	Freq. (MHz)
5725-5850 MHz Band 4 (U-NII-3)	149	5745	157	5785
	151*	5755	159*	5795
	153	5765	161	5805
	155#	5775	165	5825

Note:

- 1. The above Frequency and Channel in "*" were 802.11n HT40 and 802.11ac VHT40.
- 2. The above Frequency and Channel in "#n" were 802.11ac VHT80.



2.2 Test Mode

Final test modes are considering the modulation and worse data rates as below table.

Modulation	Data Rate
802.11a	6 Mbps
802.11n HT20	MCS0
802.11n HT40	MCS0
802.11ac VHT20 (Covered by HT20)	MCS0
802.11ac VHT40 (Covered by HT40)	MCS0
802.11ac VHT80	MCS0

Test Cases	
AC Conducted Emission	Mode 1 : GSM850 Idle + WLAN (5GHz) Link + Bluetooth Link + 3.5mm Headset + USB Cable 1 (Charging from AC Adapter 1)
Remark: For Radiated Test Cases, the tests were performed with Adapter 1 and USB Cable 1.	

Ch. #		Band IV : 5725-5850 MHz			
		802.11a	802.11n HT20	802.11n HT40	802.11ac VHT80
L	Low	149	149	151	-
M	Middle	157	157	-	155
H	High	165	165	159	-

Remark: For radiation spurious emission, the final modulation and the worst data rate was reference the max RF conducted power.

2.3 Connection Diagram of Test System

<AC Conducted Emissions Mode>

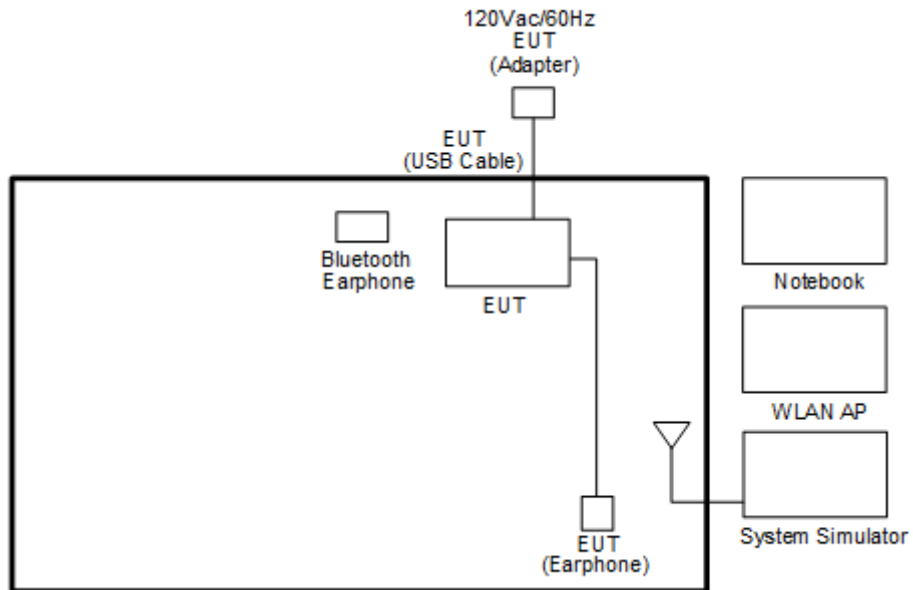

<WLAN Tx Mode>

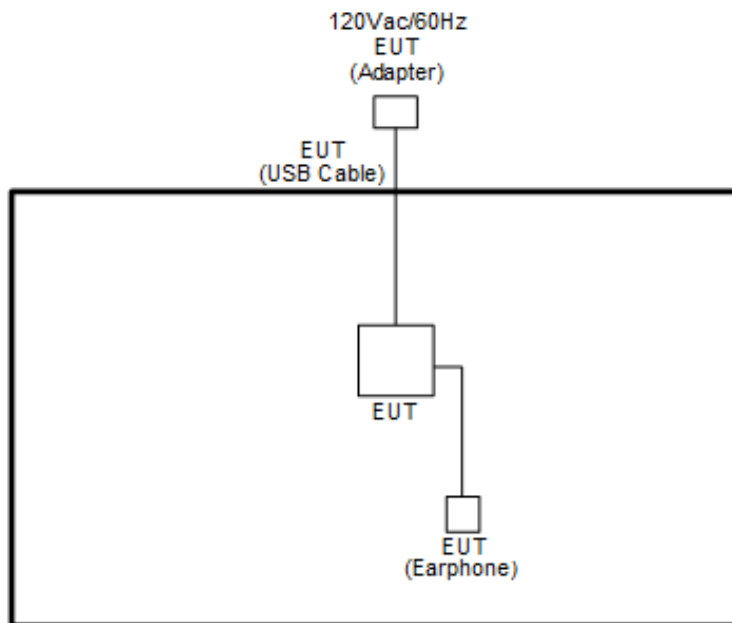

2.4 Support Unit used in test configuration and system

Item	Equipment	Trade Name	Model Name	FCC ID	Data Cable	Power Cord
1.	System Simulator	Anritsu	MT8820C	N/A	N/A	Unshielded, 1.8 m
2.	Bluetooth Earphone	Google	G015B	SZGG015B	N/A	N/A
3.	WLAN AP	ASUS	RT-AC66U	MSQ-RTAC66U	N/A	Unshielded, 1.8 m
4.	Notebook	DELL	Latitude 3400	FCC DoC	N/A	AC I/P: Unshielded, 1.2 m DC O/P: Shielded, 1.8 m
5.	Notebook	DELL	P79G	N/A	N/A	AC I/P: Unshielded, 1.2 m DC O/P: Shielded, 1.8 m

2.5 EUT Operation Test Setup

The RF test items, utility “QRCT v4.0.00158.0” was installed in Notebook which was programmed in order to make the EUT get into the engineering modes to provide channel selection, power level, data rate and the application type and for continuous transmitting signals.

2.6 Measurement Results Explanation Example

For all conducted test items:

The offset level is set in the spectrum analyzer to compensate the RF cable loss and attenuator factor between EUT conducted output port and spectrum analyzer. With the offset compensation, the spectrum analyzer reading level is exactly the EUT RF output level.

Example :

The spectrum analyzer offset is derived from RF cable loss and attenuator factor.

Offset = RF cable loss + attenuator factor.

Following shows an offset computation example with cable loss 4.2 dB and 10dB attenuator.

$$\begin{aligned}
 \text{Offset(dB)} &= \text{RF cable loss(dB)} + \text{attenuator factor(dB)}. \\
 &= 4.2 + 10 = 14.2 \text{ (dB)}
 \end{aligned}$$

3 Test Result

3.1 6dB and 26dB and 99% Occupied Bandwidth Measurement

3.1.1 Description of 6dB and 26dB and 99% Occupied Bandwidth

The minimum 6 dB bandwidth shall be at least 500 kHz.

26dB and 99% Occupied bandwidth are reporting only.

3.1.2 Measuring Instruments

See list of measuring equipment of this test report.

3.1.3 Test Procedures

1. The testing follows FCC KDB 789033 D02 General UNII Test Procedures New Rules v02r01. Section C) Emission bandwidth for the band 5.725-5.85GHz
2. Set RBW = 100kHz.
3. Set the VBW $\geq 3 \times$ RBW.
4. Detector = Peak.
5. Trace mode = max hold
6. Measure the maximum width of the emission that is 6 dB down from the peak of the emission.
7. Measure and record the results in the test report.

3.1.4 Test Setup

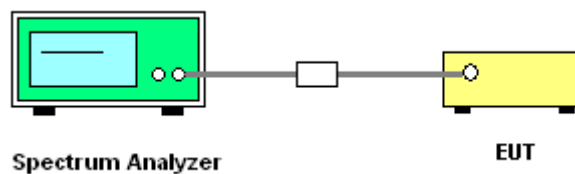

3.1.5 Test Result of 6dB and 26dB and 99% Occupied Bandwidth

Please refer to Appendix A.

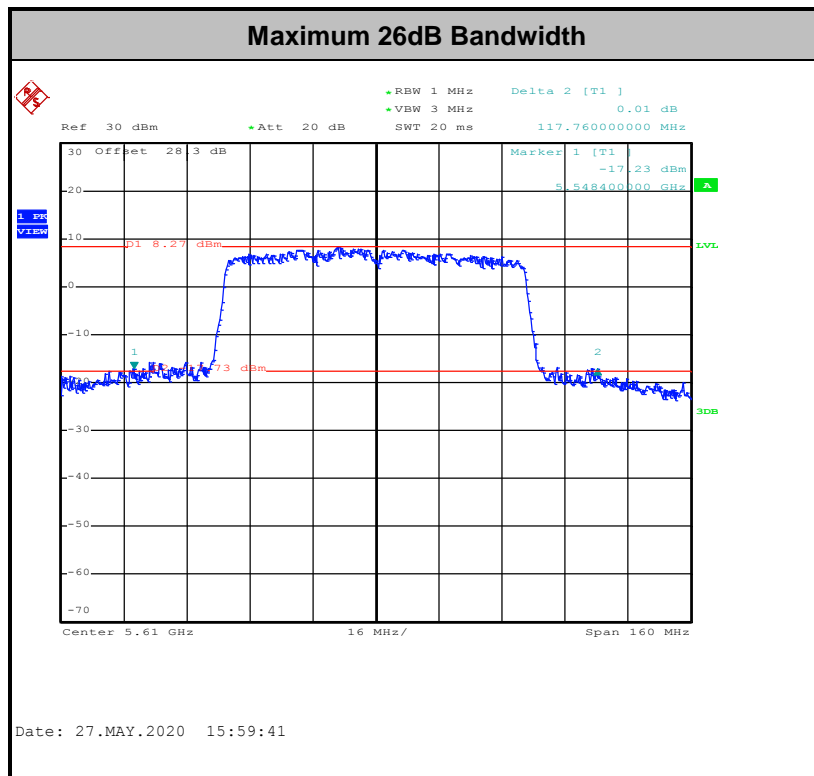
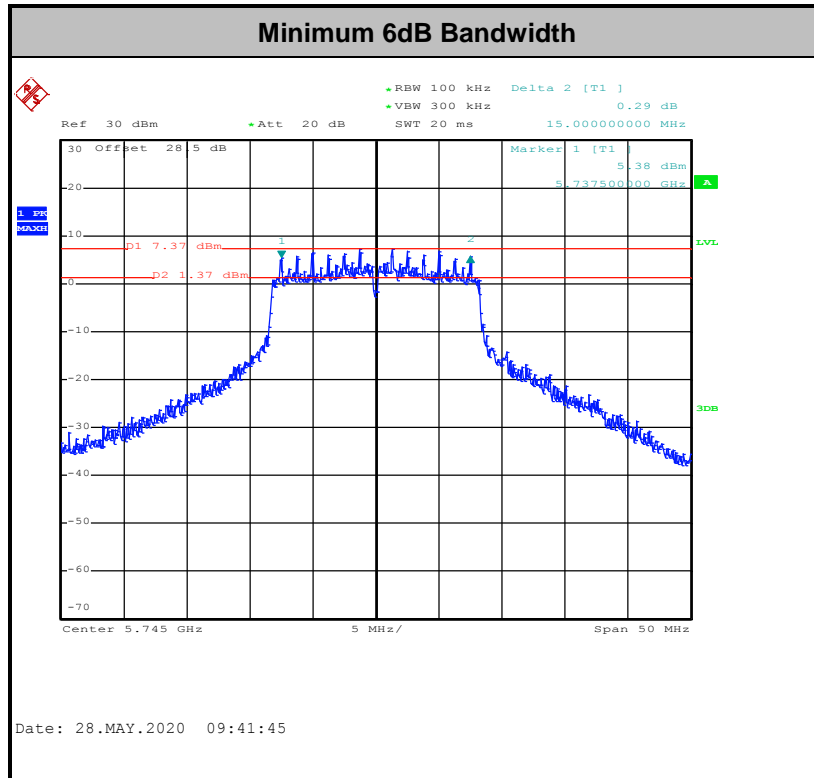

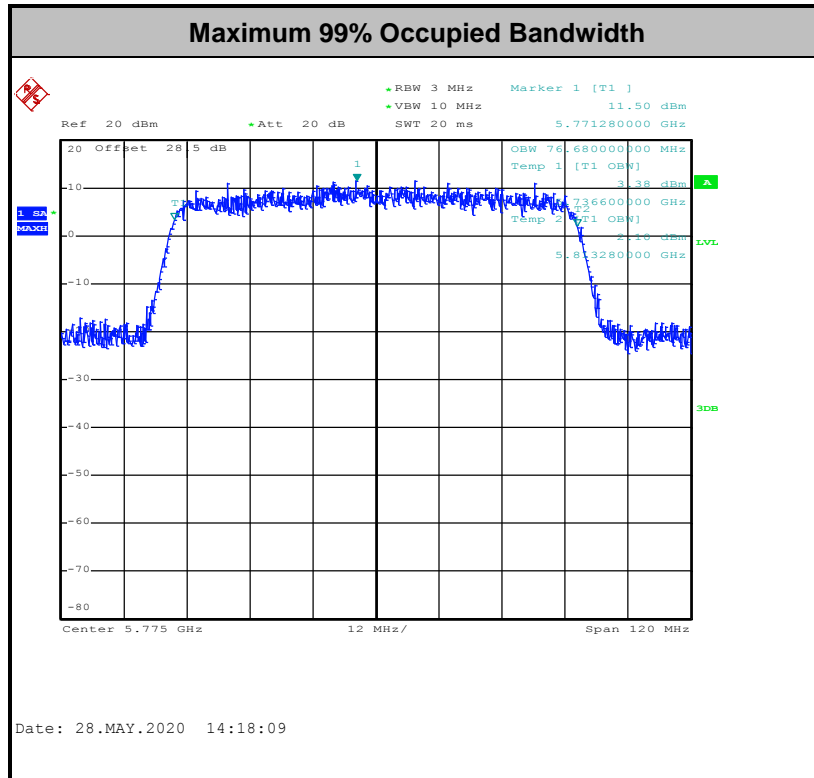

Note: The occupied channel bandwidth is maintained within the band of operation for all of the modulations.

3.2 Maximum Conducted Output Power Measurement

3.2.1 Limit of Maximum Conducted Output Power

For the band 5.725–5.85 GHz, the maximum conducted output power over the frequency band of operation shall not exceed 1 W.

If transmitting antennas of directional gain greater than 6 dBi are used, the peak output power shall be reduced by the amount in dB that the directional gain of the antenna exceeds 6 dBi.

3.2.2 Measuring Instruments

See list of measuring equipment of this test report.

3.2.3 Test Procedures

The testing follows Method PM-G of FCC KDB 789033 D02 General UNII Test Procedures New Rules v02r01.

Method PM-G (Measurement using a gated RF average power meter):

1. Measurement is performed using a wideband RF power meter.
2. The EUT is configured to transmit at its maximum power control level.
3. Measure the average power of the transmitter
4. Since the measurement is made only during the ON time of the transmitter, no duty cycle correction factor is required.

3.2.4 Test Setup

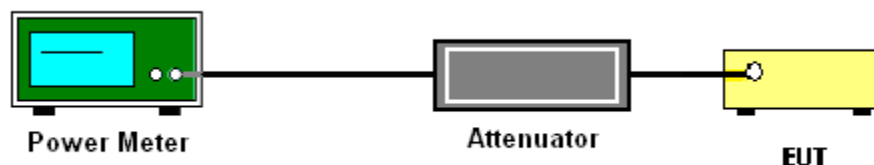

3.2.5 Test Result of Maximum Conducted Output Power

Please refer to Appendix A.



3.3 Power Spectral Density Measurement

3.3.1 Limit of Power Spectral Density

For the band 5.725–5.85 GHz, the maximum power spectral density shall not exceed 30 dBm in any 500-kHz band.

If transmitting antennas of directional gain greater than 6 dBi are used, the peak output power shall be reduced by the amount in dB that the directional gain of the antenna exceeds 6 dBi.

3.3.2 Measuring Instruments

See list of measuring equipment of this test report.

3.3.3 Test Procedures

The testing follows FCC KDB 789033 D02 General UNII Test Procedures New Rules v02r01. Section F) Maximum power spectral density.

Method SA-3

(power averaging (rms) detection with max hold):

- Set span to encompass the entire emission bandwidth (EBW) of the signal.
- Set RBW = 300 kHz.
- Set VBW \geq 1 MHz.
- Number of points in sweep \geq 2 Span / RBW.
- Sweep time \leq (number of points in sweep) \times T, when duty cycle is less than 98 percent where T is the minimum transmission duration over which the transmitter is on and is transmitting at its maximum power control level for the tested mode of operation.
- Detector = power averaging (rms).
- Trace mode = max hold.
- Allow max hold to run for at least 60 seconds, or longer as needed to allow the trace to stabilize.

1. The RF output of EUT was connected to the spectrum analyzer by a low loss cable.
2. Each plot has already offset with cable loss, and attenuator loss. Measure the PPSD and record it.
3. For MIMO mode, calculation method follows FCC KDB 662911 D01 Multiple Transmitter Output v02r01.

Method (c): Measure and add $10 \log(N_{\text{ANT}})$ dB.

With this technique, spectrum measurements are performed at each output of the device, but rather than summing the spectra or the spectral peaks across the outputs, the quantity $10 \log(N_{\text{ANT}})$ dB is added to each spectrum value before comparing to the emission limit. The addition of $10 \log(N_{\text{ANT}})$ dB serves to apportion the emission limit among the N_{ANT} outputs so that each output is permitted to contribute no more than $1/N_{\text{ANT}}^{\text{th}}$ of the PSD limit.

3.3.4 Test Setup

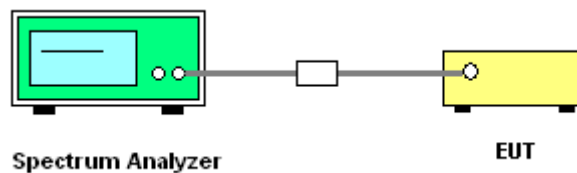

3.3.5 Test Result of Power Spectral Density

Please refer to Appendix A.



Worst Case Power Density (dBm/MHz) for MIMO Ant. 4

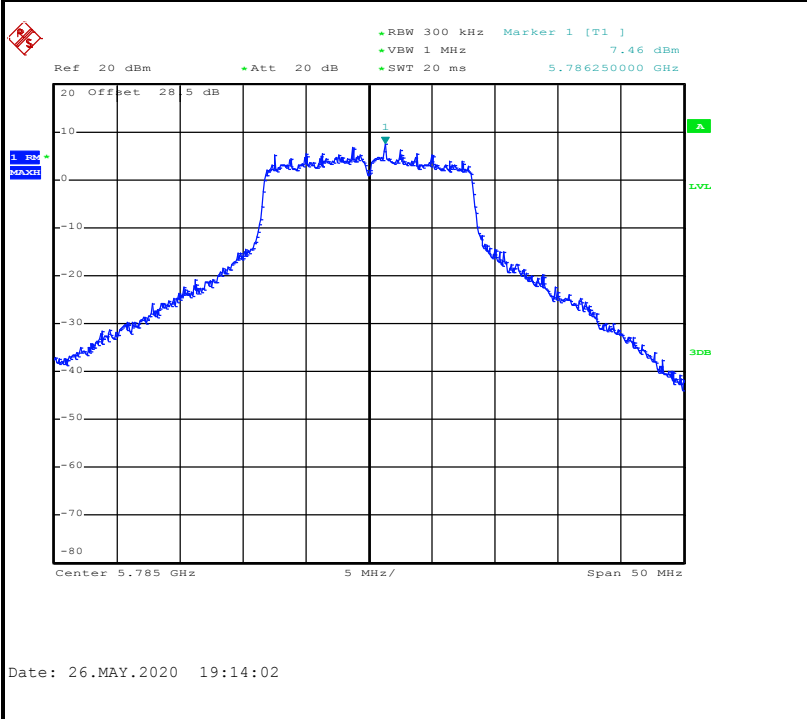

Worst Case Power Density (dBm/MHz) for MIMO Ant. 3

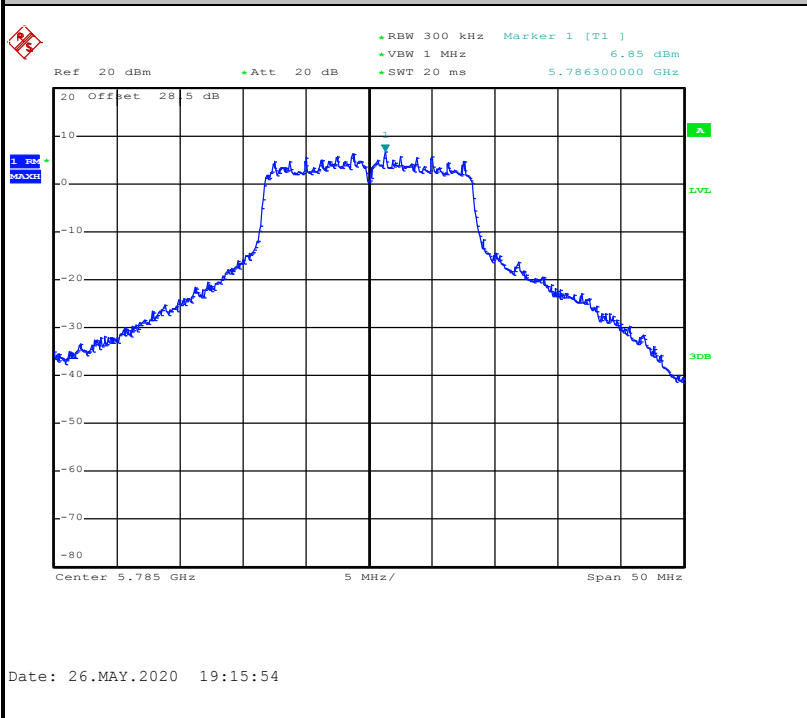



3.4 Unwanted Emissions Measurement

This section is to measure unwanted emissions through radiated measurement for band edge spurious emissions and out of band emissions measurement.

3.4.1 Limit of Unwanted Emissions

(1) For transmitters operating in the 5.725-5.85 GHz band:

15.407(b)(4)(i) All emissions shall be limited to a level of -27 dBm/MHz at 75 MHz or more above or below the band edge increasing linearly to 10 dBm/MHz at 25 MHz above or below the band edge, and from 25 MHz above or below the band edge increasing linearly to a level of 15.6 dBm/MHz at 5 MHz above or below the band edge, and from 5 MHz above or below the band edge increasing linearly to a level of 27 dBm/MHz at the band edge.

(2) Unwanted spurious emissions fallen in restricted bands shall comply with the general field strength limits as below table,

Frequency (MHz)	Field Strength (microvolts/meter)	Measurement Distance (meters)
0.009 – 0.490	2400/F(kHz)	300
0.490 – 1.705	24000/F(kHz)	30
1.705 – 30.0	30	30
30 – 88	100	3
88 – 216	150	3
216 - 960	200	3
Above 960	500	3

Note: The following formula is used to convert the EIRP to field strength.

$$E = \frac{1000000\sqrt{30P}}{3} \text{ } \mu\text{V/m, where P is the eirp (Watts)}$$

EIRP (dBm)	Field Strength at 3m (dBμV/m)
- 27	68.3

(3) KDB789033 D02 v02r01 G)2)c)

(i) Sections 15.407(b)(1-3) specifies the unwanted emissions limit for the U-NII-1 and U-NII-2 bands. As specified, emissions above 1000 MHz that are outside of the restricted bands are subject to a peak emission limit of -27 dBm/MHz.

(ii) Section 15.407(b)(4) specifies the unwanted emissions limit for the U-NII-3 band. A band emissions mask is specified in Section 15.407(b)(4)(i). The emission limits are based on the use of a peak detector.



3.4.2 Measuring Instruments

See list of measuring equipment of this test report.

3.4.3 Test Procedures

1. The testing follows FCC KDB 789033 D02 General UNII Test Procedures New Rules v02r01. Section G) Unwanted emissions measurement.
 - (1) Procedure for Unwanted Emissions Measurements Below 1000MHz
 - RBW = 120 kHz
 - VBW = 300 kHz
 - Detector = Peak
 - Trace mode = max hold
 - (2) Procedure for Peak Unwanted Emissions Measurements Above 1000 MHz
 - RBW = 1 MHz
 - VBW \geq 3 MHz
 - Detector = Peak
 - Sweep time = auto
 - Trace mode = max hold
 - (3) Procedures for Average Unwanted Emissions Measurements Above 1000MHz
 - RBW = 1 MHz
 - VBW = 10 Hz, when duty cycle is no less than 98 percent.
 - VBW \geq 1/T, when duty cycle is less than 98 percent where T is the minimum transmission duration over which the transmitter is on and is transmitting at its maximum power control level for the tested mode of operation.
2. The EUT was placed on a turntable with 0.8 meter for frequency below 1GHz and 1.5 meter for frequency above 1GHz respectively above ground.
3. The EUT was set 3 meters from the interference receiving antenna which was mounted on the top of a variable height antenna tower.
4. The antenna is a broadband antenna and its height is adjusted between one meter and four meters above ground to find the maximum value of the field strength for both horizontal polarization and vertical polarization of the antenna.
5. For each suspected emission, the EUT was arranged to its worst case and then adjust the antenna tower (from 1 m to 4 m) and turntable (from 0 degree to 360 degrees) to find the maximum reading.
6. For testing below 1GHz, if the emission level of the EUT in peak mode was 3 dB lower than the limit specified, then peak values of EUT will be reported, otherwise, the emissions will be repeated one by one using the CISPR quasi-peak method and reported.
7. For testing above 1GHz, the emission level of the EUT in peak mode was 20dB lower than average limit (that means the emission level in average mode also complies with the limit in average mode), then peak values of EUT will be reported, otherwise, the emissions will be measured in average mode again and reported.

3.4.4 Test Setup

For radiated emissions below 30MHz

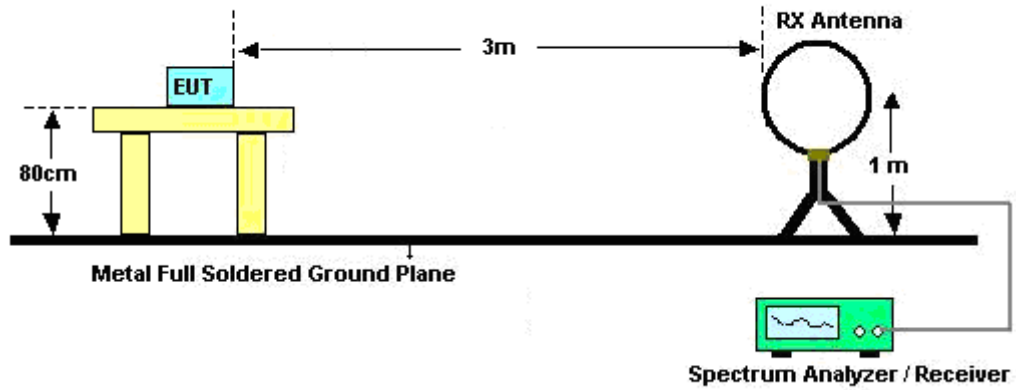

For radiated emissions from 30MHz to 1GHz

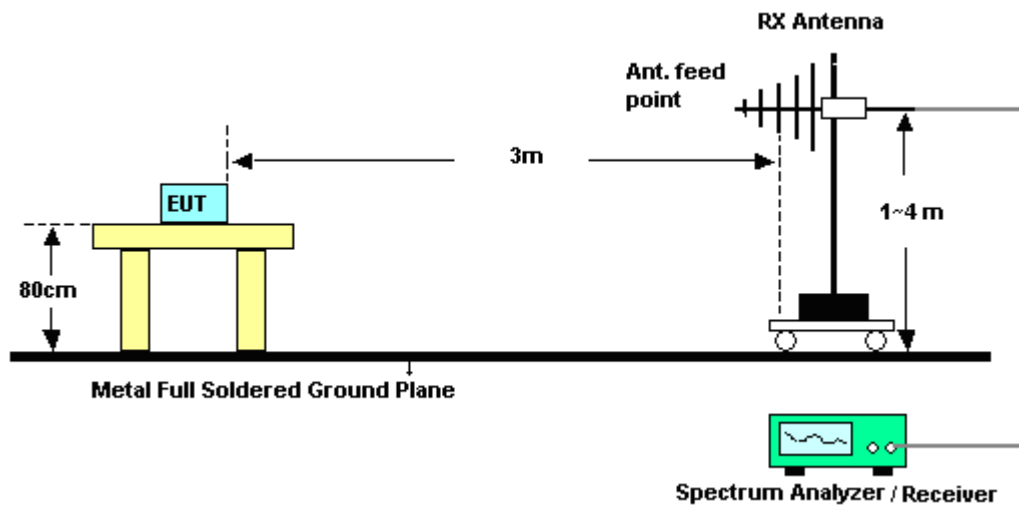

For radiated emissions above 1GHz

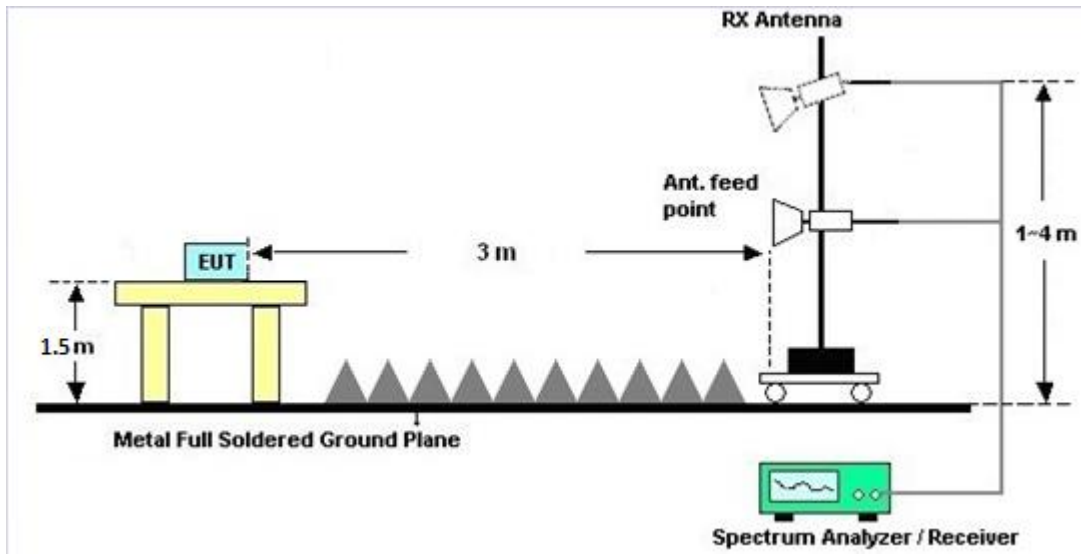

For radiated emissions above 18GHz

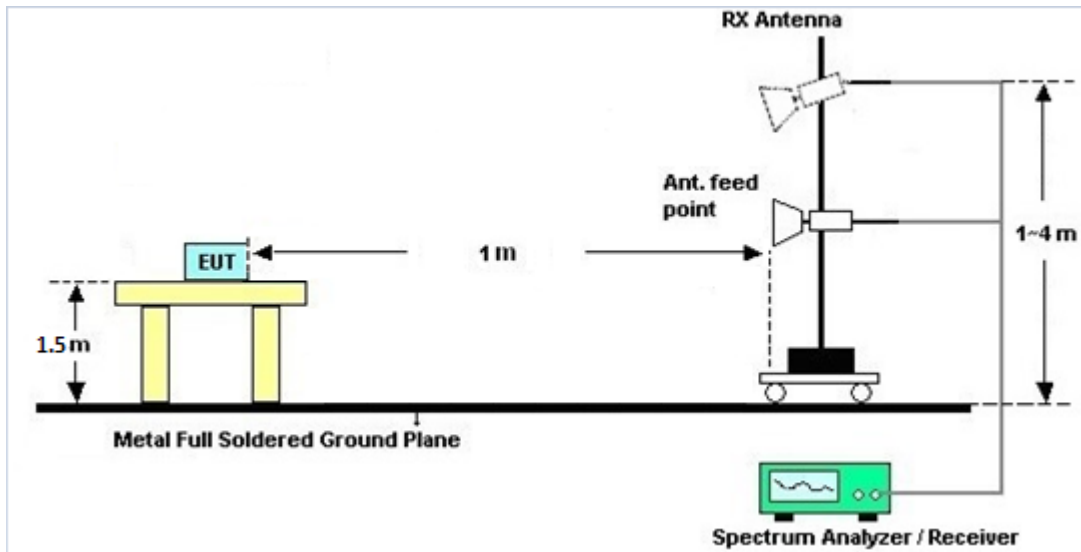



3.4.5 Test Results of Radiated Emissions (9 kHz ~ 30 MHz)

The low frequency, which started from 9 kHz to 30MHz, was pre-scanned and the result which was 20dB lower than the limit line was not reported.

There is a comparison data of both open-field test site and alternative test site - semi-Anechoic chamber according to 414788 D01 Radiated Test Site v01r01, and the result came out very similar.

3.4.6 Test Result of Radiated Band Edges

Please refer to Appendix C and D.

3.4.7 Duty Cycle

Please refer to Appendix E.

3.4.8 Test Result of Unwanted Radiated Emission (30MHz ~ 10th Harmonic)

Please refer to Appendix C and D.



3.5 AC Conducted Emission Measurement

3.5.1 Limit of AC Conducted Emission

For equipment that is designed to be connected to the public utility (AC) power line, the radio frequency voltage that is conducted back onto the AC power line on any frequency or frequencies within the band 150 kHz to 30 MHz shall not exceed the limits in the following table.

Frequency of emission (MHz)	Conducted limit (dBµV)	
	Quasi-peak	Average
0.15-0.5	66 to 56*	56 to 46*
0.5-5	56	46
5-30	60	50

*Decreases with the logarithm of the frequency.

3.5.2 Measuring Instruments

See list of measuring equipment of this test report.

3.5.3 Test Procedures

1. The EUT was placed 0.4 meter from the conducting wall of the shielding room was kept at least 80 centimeters from any other grounded conducting surface.
2. Connect EUT to the power mains through a line impedance stabilization network (LISN).
3. All the support units are connecting to the other LISN.
4. The LISN provides 50 ohm coupling impedance for the measuring instrument.
5. The FCC states that a 50 ohm, 50 microhenry LISN should be used.
6. Both sides of AC line were checked for maximum conducted interference.
7. The frequency range from 150 kHz to 30 MHz was searched.
8. Set the test-receiver system to Peak Detect Function and specified bandwidth with Maximum Hold Mode.

3.5.4 Test Setup

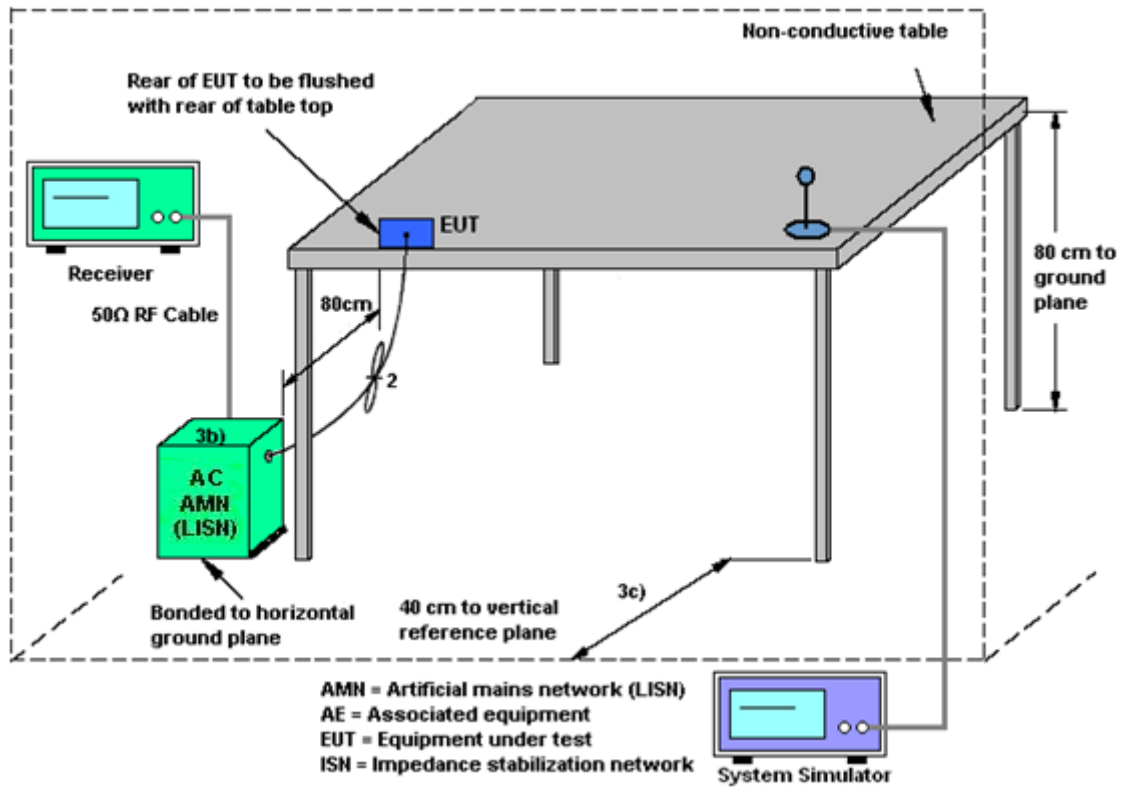

3.5.5 Test Result of AC Conducted Emission

Please refer to Appendix B.



3.6 Automatically Discontinue Transmission

3.6.1 Limit of Automatically Discontinue Transmission

The device shall automatically discontinue transmission in case of either absence of information to transmit or operational failure. These provisions are not intended to preclude the transmission of control or signaling information or the use of repetitive codes used by certain digital technologies to complete frame or burst intervals. Applicants shall include in their application for equipment authorization to describe how this requirement is met.

3.6.2 Measuring Instruments

See list of measuring equipment of this test report.

3.6.3 Test Result of Automatically Discontinue Transmission

EUT is verified this characteristic during the function check of normal sample associated with an access point:

- A. Information start: make EUT supply information to the access point.
- B. Information stop: stop supplying information to the access point.

While the EUT is not transmitting any information, the EUT can automatically discontinue transmission and become standby mode for power saving.

- C. Information start: make EUT supply information to the access point again.

The EUT can detect the controlling signal of ACK message transmitting from remote device and verify whether it shall resend or discontinue transmission.

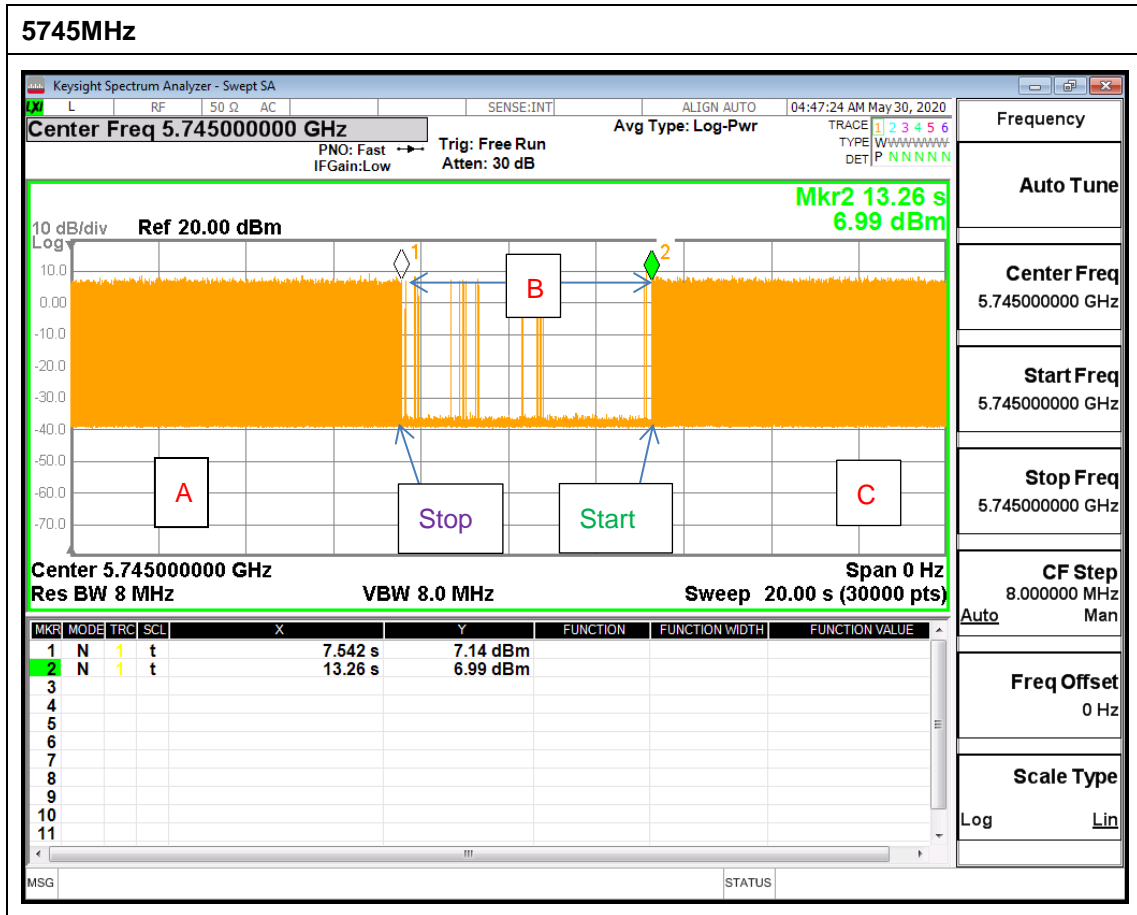

Note: The control / signalling information during the period B is precluded.



3.7 Antenna Requirements

3.7.1 Standard Applicable

If transmitting antenna directional gain is greater than 6 dBi, both the peak transmit power and the peak power spectral density shall be reduced by the amount in dB that the directional gain of the antenna exceeds 6 dBi.

3.7.2 Antenna Anti-Replacement Construction

An embedded-in antenna design is used.

3.7.3 Antenna Gain

<CDD Modes >

FCC KDB 662911 D01 Multiple Transmitter Output v02r01

For CDD transmissions, directional gain is calculated as

Directional gain = GANT + Array Gain, where Array Gain is as follows.

For power spectral density (PSD) measurements on all devices,

Array Gain = 10 log(NANT/NSS=1) dB.

For power measurements on IEEE 802.11 devices,

Array Gain = 0 dB (i.e., no array gain) for NANT ≤ 4.

Directional gain may be calculated by using the formulas applicable to equal gain antennas with GANT set equal to the gain of the antenna having the highest gain;

The EUT supports CDD mode.

For power, the directional gain GANT is set equal to the antenna having the highest gain, i.e., F)2)f)i).

For PSD, the directional gain calculation is following F)2)f)ii) of KDB 662911 D01 v02r01.

The power and PSD limit should be modified if the directional gain of EUT is over 6 dBi,

The directional gain "DG" is calculated as following table.

<CDD Modes>						
			DG for Power (dBi)	DG for PSD (dBi)	Power Limit Reduction (dB)	PSD Limit Reduction (dB)
	Ant. 4 (dBi)	Ant. 3 (dBi)				
Band IV	-1.80	-0.50	-0.50	1.88	0.00	0.00

Power Limit Reduction = DG(Power) – 6dBi, (min = 0)

PSD Limit Reduction = DG(PSD) – 6dBi, (min = 0)



4 List of Measuring Equipment

Instrument	Manufacturer	Model No.	Serial No.	Characteristics	Calibration Date	Test Date	Due Date	Remark
Bilog Antenna	TESEQ	CBL 6111D & 00800N1D01 N-06	35419 & 03	30MHz~1GHz	Apr. 29, 2020	May 15, 2020~Jun. 19, 2020	Apr. 28, 2021	Radiation (03CH07-HY)
Double Ridge Horn Antenna	ESCO	3117	00075962	1GHz ~ 18GHz	Dec. 06, 2019	May 15, 2020~Jun. 19, 2020	Dec. 05, 2020	Radiation (03CH07-HY)
EMI Test Receiver	Agilent	N9038A (MXE)	MY5329005 3	20Hz~26.5GHz	Jan. 18, 2020	May 15, 2020~Jun. 19, 2020	Jan. 17, 2021	Radiation (03CH07-HY)
Loop Antenna	Rohde & Schwarz	HFH2-Z2	100315	9 kHz~30 MHz	Dec. 26, 2019	May 15, 2020~Jun. 19, 2020	Dec. 25, 2020	Radiation (03CH07-HY)
Preamplifier	MITEQ	AMF-7D-0010 1800-30-10P	1590075	1GHz~18GHz	Apr. 23, 2020	May 15, 2020~Jun. 19, 2020	Apr. 22, 2021	Radiation (03CH07-HY)
Preamplifier	COM-POWER	PA-103A	161241	10MHz~1GHz	May 20, 2019	May 15, 2020~May 18, 2020	May 19, 2020	Radiation (03CH07-HY)
Preamplifier	COM-POWER	PA-103A	161241	10MHz~1GHz	May 19, 2020	May 19, 2020~Jun. 19, 2020	May 18, 2021	Radiation (03CH07-HY)
Preamplifier	Agilent	8449B	3008A02362	1GHz~26.5GHz	Nov. 01, 2019	May 15, 2020~Jun. 19, 2020	Oct. 31, 2020	Radiation (03CH07-HY)
RF Cable	HUBER + SUHNER	SUCOFLEX 102	MY2858/2,8 01606/2	18GHz~40GHz	Feb. 25, 2020	May 15, 2020~Jun. 19, 2020	Feb. 24, 2021	Radiation (03CH07-HY)
RF Cable	HUBER + SUHNER	SUCOFLEX 104	MY24971/4, MY28655/4	9kHz~30MHz	Feb. 25, 2020	May 15, 2020~Jun. 19, 2020	Feb. 24, 2021	Radiation (03CH07-HY)
RF Cable	HUBER + SUHNER	SUCOFLEX 104	MY28655/4, MY24971/4, MY15682/4	30MHz~1GHz	Feb. 25, 2020	May 15, 2020~Jun. 19, 2020	Feb. 24, 2021	Radiation (03CH07-HY)
RF Cable	HUBER + SUHNER	SUCOFLEX 104	MY28655/4, MY24971/4, MY15682/4	1GHz~18GHz	Feb. 25, 2020	May 15, 2020~Jun. 19, 2020	Feb. 24, 2021	Radiation (03CH07-HY)
Controller	ChainTek	Chaintek 3000	N/A	Control Turn table	N/A	May 15, 2020~Jun. 19, 2020	N/A	Radiation (03CH07-HY)
Controller	Max-Full	MF7802	MF7802083 68	Control Ant Mast	N/A	May 15, 2020~Jun. 19, 2020	N/A	Radiation (03CH07-HY)
Antenna Mast	Max-Full	MFA520BS	N/A	1m~4m	N/A	May 15, 2020~Jun. 19, 2020	N/A	Radiation (03CH07-HY)
Turn Table	ChainTek	Chaintek 3000	N/A	0~360 Degree	N/A	May 15, 2020~Jun. 19, 2020	N/A	Radiation (03CH07-HY)
USB Data Logger	TECPEL	TR-32	HE17XB249 5	N/A	N/A	May 15, 2020~Jun. 19, 2020	N/A	Radiation (03CH07-HY)
Spectrum Analyzer	Keysight	N9010A	MY5420048 6	10Hz~44GHz	Oct. 28, 2019	May 15, 2020~Jun. 19, 2020	Oct. 27, 2020	Radiation (03CH07-HY)
SHF-EHF Horn Antenna	SCHWARZBECK	BBHA 9170	BBHA91705 84	18GHz~40GHz	Dec. 10, 2019	May 15, 2020~Jun. 19, 2020	Dec. 09, 2020	Radiation (03CH07-HY)
Software	Audix	E3 6.2009-8-24	N/A	N/A	N/A	May 15, 2020~Jun. 19, 2020	N/A	Radiation (03CH07-HY)
Preamplifier	EMEC	EM18G40G	060715	18GHz~40GHz	Dec. 13, 2019	May 15, 2020~Jun. 19, 2020	Dec. 12, 2020	Radiation (03CH07-HY)



Instrument	Manufacturer	Model No.	Serial No.	Characteristics	Calibration Date	Test Date	Due Date	Remark
AC Power Source	ChainTek	APC-1000W	N/A	N/A	N/A	May 19, 2020	N/A	Conduction (CO05-HY)
EMI Test Receiver	Rohde & Schwarz	ESR3	102388	9kHz~3.6GHz	Nov. 15, 2019	May 19, 2020	Nov. 14, 2020	Conduction (CO05-HY)
Hygrometer	Testo	608-H1	34913912	N/A	Nov. 07, 2019	May 19, 2020	Nov. 06, 2020	Conduction (CO05-HY)
LISN	Rohde & Schwarz	ENV216	100080	9kHz~30MHz	Nov. 20, 2019	May 19, 2020	Nov. 19, 2020	Conduction (CO05-HY)
LISN	Rohde & Schwarz	ENV216	100081	9kHz~30MHz	Nov. 15, 2019	May 19, 2020	Nov. 14, 2020	Conduction (CO05-HY)
Software	Rohde & Schwarz	EMC32 V10.30	N/A	N/A	N/A	May 19, 2020	N/A	Conduction (CO05-HY)
LF Cable	HUBER + SUHNER	RG-214/U	LF01	N/A	Jan. 02, 2020	May 19, 2020	Jan. 01, 2021	Conduction (CO05-HY)
Pulse Limiter	Rohde & Schwarz	ESH3-Z2	100851	N/A	Jan. 02, 2020	May 19, 2020	Jan. 01, 2021	Conduction (CO05-HY)
Hygrometer	Testo	608-H2	41410069	N/A	Jun. 17, 2019	May 08, 2020~ May 28, 2020	Jun. 16, 2020	Conducted (TH05-HY)
Power Sensor	DARE	RPR3006W	16I00054SN O10	10MHz~6GHz	Dec. 23, 2019	May 08, 2020~ May 28, 2020	Dec. 22, 2020	Conducted (TH05-HY)
Spectrum Analyzer	Rohde & Schwarz	FSP40	100055	9kHz~40GHz	Aug. 14, 2019	May 08, 2020~ May 28, 2020	Aug. 13, 2020	Conducted (TH05-HY)
Switch Box & RF Cable	Burgeon	ETF-058	EC1300484	N/A	Aug. 22, 2019	May 08, 2020~ May 28, 2020	Aug. 21, 2020	Conducted (TH05-HY)
Power Supply	GW Instek	SPS-606	GES842931	NA	Aug. 19, 2019	May 08, 2020~ May 28, 2020	Aug. 18, 2020	Conducted (TH05-HY)
Spectrum Analyzer	Keysight	N9010A	MY5607041 2	10Hz~7GHz	Aug. 27, 2019	May 30, 2020	Aug. 26, 2020	Conducted (TH05-HY)



5 Uncertainty of Evaluation

Uncertainty of Conducted Emission Measurement (150kHz ~ 30MHz)

Measuring Uncertainty for a Level of Confidence of 95% ($U = 2Uc(y)$)	2.3
---	-----

Uncertainty of Radiated Emission Measurement (30 MHz ~ 1000 MHz)

Measuring Uncertainty for a Level of Confidence of 95% ($U = 2Uc(y)$)	4.6
---	-----

Uncertainty of Radiated Emission Measurement (1000 MHz ~ 18000 MHz)

Measuring Uncertainty for a Level of Confidence of 95% ($U = 2Uc(y)$)	5.2
---	-----

Uncertainty of Radiated Emission Measurement (18000 MHz ~ 40000 MHz)

Measuring Uncertainty for a Level of Confidence of 95% ($U = 2Uc(y)$)	5.3
---	-----

Appendix A. Test Result of Conducted Test Items

Test Engineer:	Kathy Chen	Temperature:	20.1~22.1	°C
Test Date:	2020/05/08~2020/05/28	Relative Humidity:	45.7~58.8	%

TEST RESULTS DATA
6dB and 26dB EBW and 99% OBW

Band IV MIMO												
Mod.	Data Rate	NTX	CH.	Freq. (MHz)	99% Bandwidth (MHz)		26dB Bandwidth (MHz)		6 dB Bandwidth (MHz)		6 dB Bandwidth Min. Limit (MHz)	Pass/Fail
					Ant 4	Ant 3	Ant 4	Ant 3	Ant 4	Ant 3		
11a	6Mbps	2	149	5745	16.90	16.90	25.90	27.00	15.10	15.00	0.5	Pass
11a	6Mbps	2	157	5785	17.00	17.00	27.10	27.50	15.10	15.00	0.5	Pass
11a	6Mbps	2	165	5825	17.00	16.85	26.70	26.00	15.10	15.10	0.5	Pass
HT20	MCS0	2	149	5745	18.05	18.20	28.40	30.60	15.90	16.10	0.5	Pass
HT20	MCS0	2	157	5785	18.00	18.10	28.90	28.25	15.90	15.40	0.5	Pass
HT20	MCS0	2	165	5825	18.05	18.00	30.70	28.10	15.90	15.95	0.5	Pass
HT40	MCS0	2	151	5755	36.80	36.70	41.63	42.30	35.28	34.92	0.5	Pass
HT40	MCS0	2	159	5795	36.60	36.50	41.68	41.66	35.64	34.92	0.5	Pass
VHT80	MCS0	2	155	5775	76.56	76.68	82.56	82.88	75.20	75.20	0.5	Pass

TEST RESULTS DATA
Average Power Table

Band IV single antenna												
Mod.	Data Rate	NTX	CH.	Freq. (MHz)	Average Conducted Power (dBm)			FCC Conducted Power Limit (dBm)		DG (dBi)		Pass/Fail
					Ant 4	Ant 3	SUM	Ant 4	Ant 3	Ant 4	Ant 3	
11a	6Mbps	1	149	5745	18.20	17.60		30.00	30.00	-1.80	-0.50	Pass
11a	6Mbps	1	157	5785	18.30	17.80		30.00	30.00	-1.80	-0.50	Pass
11a	6Mbps	1	165	5825	18.30	17.50		30.00	30.00	-1.80	-0.50	Pass
HT20	MCS0	1	149	5745	18.20	17.80		30.00	30.00	-1.80	-0.50	Pass
HT20	MCS0	1	157	5785	18.30	17.70		30.00	30.00	-1.80	-0.50	Pass
HT20	MCS0	1	165	5825	18.30	17.70		30.00	30.00	-1.80	-0.50	Pass
HT40	MCS0	1	151	5755	17.30	17.00		30.00	30.00	-1.80	-0.50	Pass
HT40	MCS0	1	159	5795	17.30	16.70		30.00	30.00	-1.80	-0.50	Pass
VHT20	MCS0	1	149	5745	18.10	17.70		30.00	30.00	-1.80	-0.50	Pass
VHT20	MCS0	1	157	5785	18.20	17.60		30.00	30.00	-1.80	-0.50	Pass
VHT20	MCS0	1	165	5825	18.20	17.60		30.00	30.00	-1.80	-0.50	Pass
VHT40	MCS0	1	151	5755	17.20	16.90		30.00	30.00	-1.80	-0.50	Pass
VHT40	MCS0	1	159	5795	17.20	16.60		30.00	30.00	-1.80	-0.50	Pass
VHT80	MCS0	1	155	5775	16.80	16.10		30.00	30.00	-1.80	-0.50	Pass

Band IV MIMO												
Mod.	Data Rate	NTX	CH.	Freq. (MHz)	Average Conducted Power (dBm)			FCC Conducted Power Limit (dBm)		DG (dBi)		Pass/Fail
					Ant 4	Ant 3	SUM	Ant 4	Ant 3	Ant 4	Ant 3	
11a	6Mbps	2	149	5745	18.30	17.70	21.02	30.00		-0.50		Pass
11a	6Mbps	2	157	5785	18.40	17.90	21.17	30.00		-0.50		Pass
11a	6Mbps	2	165	5825	18.40	17.60	21.03	30.00		-0.50		Pass
HT20	MCS0	2	149	5745	18.30	17.90	21.11	30.00		-0.50		Pass
HT20	MCS0	2	157	5785	18.40	17.80	21.12	30.00		-0.50		Pass
HT20	MCS0	2	165	5825	18.40	17.80	21.12	30.00		-0.50		Pass
HT40	MCS0	2	151	5755	17.40	17.10	20.26	30.00		-0.50		Pass
HT40	MCS0	2	159	5795	17.40	16.80	20.12	30.00		-0.50		Pass
VHT20	MCS0	2	149	5745	18.20	17.80	21.01	30.00		-0.50		Pass
VHT20	MCS0	2	157	5785	18.30	17.70	21.02	30.00		-0.50		Pass
VHT20	MCS0	2	165	5825	18.30	17.70	21.02	30.00		-0.50		Pass
VHT40	MCS0	2	151	5755	17.30	17.00	20.16	30.00		-0.50		Pass
VHT40	MCS0	2	159	5795	17.30	16.70	20.02	30.00		-0.50		Pass
VHT80	MCS0	2	155	5775	16.90	16.20	19.57	30.00		-0.50		Pass

TEST RESULTS DATA
Power Spectral Density

Band IV MIMO														
Mod.	Data Rate	NTX	CH.	Freq. (MHz)	10log (500kHz /RBW) Factor (dB)		Average Power Density (dBm/500kHz)			Average PSD Limit (dBm/500kHz)		DG (dBi)		Pass /Fail
					Ant 4	Ant 3	Ant 4	Ant 3	SUM	Ant 4	Ant 3	Ant 4	Ant 3	
11a	6Mbps	2	149	5745	2.22	2.22	8.77	7.92	11.78	30.00	30.00	1.88	1.88	Pass
11a	6Mbps	2	157	5785	2.22	2.22	9.68	9.07	12.69	30.00	30.00	1.88	1.88	Pass
11a	6Mbps	2	165	5825	2.22	2.22	9.28	8.40	12.29	30.00	30.00	1.88	1.88	Pass
HT20	MCS0	2	149	5745	2.22	2.22	8.76	8.18	11.77	30.00	30.00	1.88	1.88	Pass
HT20	MCS0	2	157	5785	2.22	2.22	9.58	8.97	12.59	30.00	30.00	1.88	1.88	Pass
HT20	MCS0	2	165	5825	2.22	2.22	9.20	8.31	12.21	30.00	30.00	1.88	1.88	Pass
HT40	MCS0	2	151	5755	2.22	2.22	4.02	4.10	7.11	30.00	30.00	1.88	1.88	Pass
HT40	MCS0	2	159	5795	2.22	2.22	4.37	4.15	7.38	30.00	30.00	1.88	1.88	Pass
VHT80	MCS0	2	155	5775	2.22	2.22	2.79	2.34	5.80	30.00	30.00	1.88	1.88	Pass

Note: PSD Sum = Max PSD(Ant. 1, Ant. 2) + 10 log (n)



Appendix B. AC Conducted Emission Test Results

Test Engineer :	Howard Huang	Temperature :	21~25°C
		Relative Humidity :	42~45%

EUT Information

Report NO : 022521-02
 Test Mode : Mode 1
 Test Voltage : 120Vac/60Hz
 Phase : Line

Full Spectrum

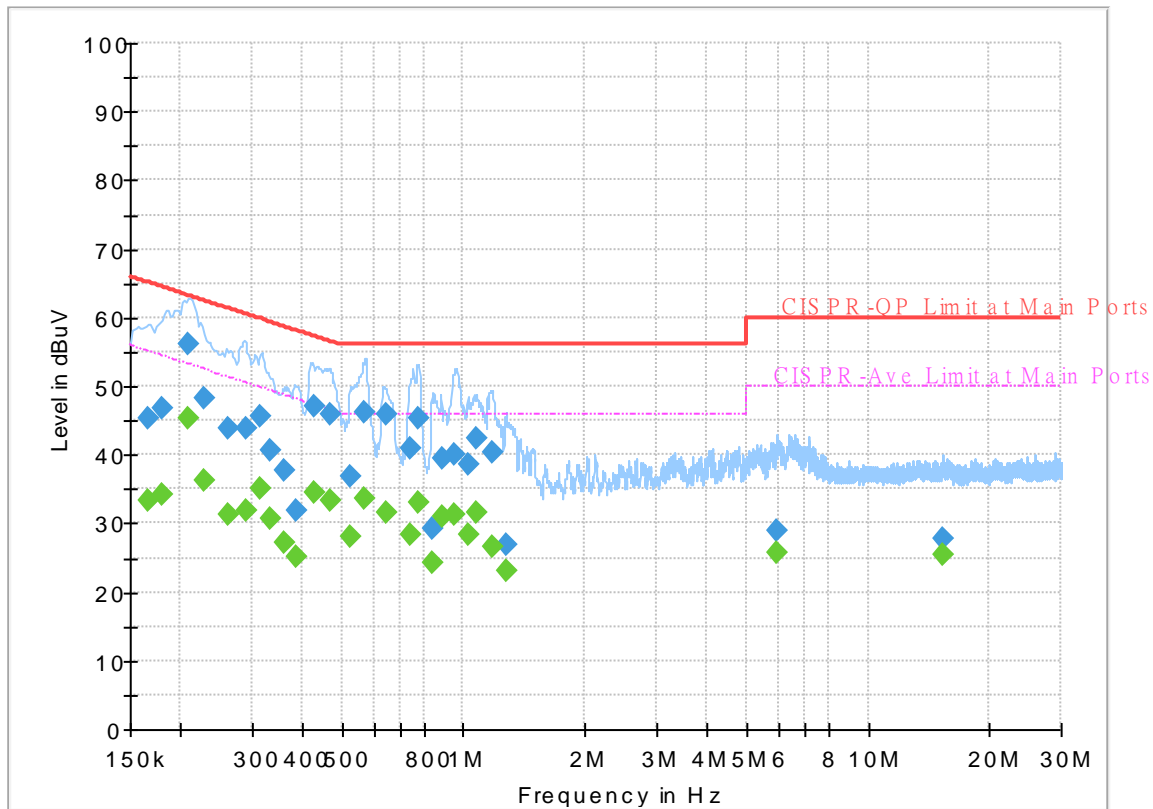

Final_Result

Frequency (MHz)	QuasiPeak (dBuV)	CAverage (dBuV)	Limit (dBuV)	Margin (dB)	Line	Filter	Corr. (dB)
0.165750	---	33.30	55.17	21.87	L1	OFF	19.6
0.165750	45.37	---	65.17	19.80	L1	OFF	19.6
0.179250	---	34.31	54.52	20.21	L1	OFF	19.6
0.179250	46.88	---	64.52	17.64	L1	OFF	19.6
0.209580	---	45.46	53.22	7.76	L1	OFF	19.6
0.209580	56.01	---	63.22	7.21	L1	OFF	19.6
0.228750	---	36.28	52.50	16.22	L1	OFF	19.6
0.228750	48.34	---	62.50	14.16	L1	OFF	19.6
0.262500	---	31.27	51.35	20.08	L1	OFF	19.6
0.262500	43.91	---	61.35	17.44	L1	OFF	19.6
0.291750	---	31.84	50.47	18.63	L1	OFF	19.6
0.291750	43.85	---	60.47	16.62	L1	OFF	19.6
0.313800	---	35.00	49.87	14.87	L1	OFF	19.6
0.313800	45.71	---	59.87	14.16	L1	OFF	19.6
0.334590	---	30.59	49.34	18.75	L1	OFF	19.6
0.334590	40.68	---	59.34	18.66	L1	OFF	19.6
0.361590	---	27.33	48.69	21.36	L1	OFF	19.6
0.361590	37.64	---	58.69	21.05	L1	OFF	19.6
0.386250	---	25.23	48.14	22.91	L1	OFF	19.6
0.386250	31.97	---	58.14	26.17	L1	OFF	19.6
0.429000	---	34.41	47.27	12.86	L1	OFF	19.6

0.429000	47.08	---	57.27	10.19	L1	OFF	19.6
0.471120	---	33.21	46.49	13.28	L1	OFF	19.6
0.471120	46.00	---	56.49	10.49	L1	OFF	19.6
0.528000	---	28.02	46.00	17.98	L1	OFF	19.6
0.528000	36.71	---	56.00	19.29	L1	OFF	19.6
0.566700	---	33.60	46.00	12.40	L1	OFF	19.6
0.566700	46.12	---	56.00	9.88	L1	OFF	19.6
0.642750	---	31.70	46.00	14.30	L1	OFF	19.6
0.642750	45.95	---	56.00	10.05	L1	OFF	19.6
0.742380	---	28.43	46.00	17.57	L1	OFF	19.6
0.742380	40.87	---	56.00	15.13	L1	OFF	19.6
0.775320	---	33.18	46.00	12.82	L1	OFF	19.6
0.775320	45.30	---	56.00	10.70	L1	OFF	19.6
0.841920	---	24.23	46.00	21.77	L1	OFF	19.6
0.841920	29.26	---	56.00	26.74	L1	OFF	19.6
0.883500	---	30.97	46.00	15.03	L1	OFF	19.6
0.883500	39.61	---	56.00	16.39	L1	OFF	19.6
0.952800	---	31.29	46.00	14.71	L1	OFF	19.6
0.952800	40.13	---	56.00	15.87	L1	OFF	19.6
1.028670	---	28.34	46.00	17.66	L1	OFF	19.6
1.028670	38.66	---	56.00	17.34	L1	OFF	19.6
1.079610	---	31.53	46.00	14.47	L1	OFF	19.6
1.079610	42.46	---	56.00	13.54	L1	OFF	19.6
1.173750	---	26.68	46.00	19.32	L1	OFF	19.6
1.173750	40.46	---	56.00	15.54	L1	OFF	19.6
1.272750	---	23.10	46.00	22.90	L1	OFF	19.6
1.272750	27.03	---	56.00	28.97	L1	OFF	19.6
5.973000	---	25.71	50.00	24.29	L1	OFF	19.9
5.973000	28.98	---	60.00	31.02	L1	OFF	19.9
15.258750	---	25.51	50.00	24.49	L1	OFF	20.2
15.258750	27.79	---	60.00	32.21	L1	OFF	20.2

EUT Information

Report NO : 022521-02
 Test Mode : Mode 1
 Test Voltage : 120Vac/60Hz
 Phase : Neutral

Full Spectrum

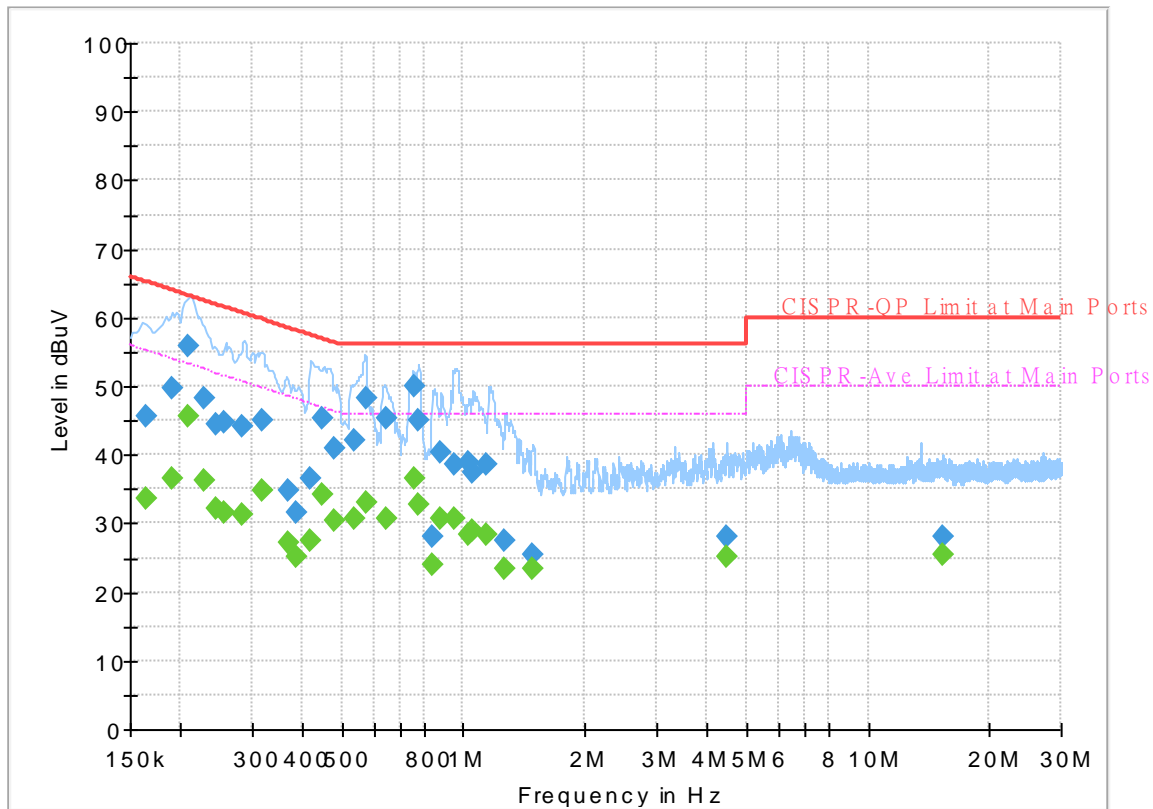

Final_Result

Frequency (MHz)	QuasiPeak (dBuV)	CAverage (dBuV)	Limit (dBuV)	Margin (dB)	Line	Filter	Corr. (dB)
0.165030	---	33.57	55.21	21.64	N	OFF	19.6
0.165030	45.75	---	65.21	19.46	N	OFF	19.6
0.190500	---	36.42	54.02	17.60	N	OFF	19.6
0.190500	49.75	---	64.02	14.27	N	OFF	19.6
0.209400	---	45.53	53.23	7.70	N	OFF	19.6
0.209400	55.93	---	63.23	7.30	N	OFF	19.6
0.228750	---	36.40	52.50	16.10	N	OFF	19.6
0.228750	48.33	---	62.50	14.17	N	OFF	19.6
0.244500	---	32.10	51.94	19.84	N	OFF	19.6
0.244500	44.47	---	61.94	17.47	N	OFF	19.6
0.254940	---	31.67	51.60	19.93	N	OFF	19.6
0.254940	44.83	---	61.60	16.77	N	OFF	19.6
0.284460	---	31.29	50.69	19.40	N	OFF	19.6
0.284460	44.03	---	60.69	16.66	N	OFF	19.6
0.317220	---	34.82	49.78	14.96	N	OFF	19.6
0.317220	45.10	---	59.78	14.68	N	OFF	19.6
0.368070	---	27.24	48.54	21.30	N	OFF	19.6
0.368070	34.66	---	58.54	23.88	N	OFF	19.6
0.386250	---	25.13	48.14	23.01	N	OFF	19.6
0.386250	31.63	---	58.14	26.51	N	OFF	19.6
0.417030	---	27.63	47.51	19.88	N	OFF	19.6

0.417030	36.66	---	57.51	20.85	N	OFF	19.6
0.447000	---	34.14	46.93	12.79	N	OFF	19.6
0.447000	45.18	---	56.93	11.75	N	OFF	19.6
0.480750	---	30.43	46.33	15.90	N	OFF	19.6
0.480750	40.99	---	56.33	15.34	N	OFF	19.6
0.534840	---	30.62	46.00	15.38	N	OFF	19.6
0.534840	42.19	---	56.00	13.81	N	OFF	19.6
0.575250	---	33.03	46.00	12.97	N	OFF	19.6
0.575250	48.19	---	56.00	7.81	N	OFF	19.6
0.641580	---	30.80	46.00	15.20	N	OFF	19.6
0.641580	45.39	---	56.00	10.61	N	OFF	19.6
0.755250	---	36.53	46.00	9.47	N	OFF	19.6
0.755250	49.92	---	56.00	6.08	N	OFF	19.6
0.771720	---	32.72	46.00	13.28	N	OFF	19.6
0.771720	44.90	---	56.00	11.10	N	OFF	19.6
0.837330	---	23.95	46.00	22.05	N	OFF	19.6
0.837330	27.99	---	56.00	28.01	N	OFF	19.6
0.876750	---	30.73	46.00	15.27	N	OFF	19.6
0.876750	40.25	---	56.00	15.75	N	OFF	19.6
0.949020	---	30.56	46.00	15.44	N	OFF	19.6
0.949020	38.56	---	56.00	17.44	N	OFF	19.6
1.029390	---	28.32	46.00	17.68	N	OFF	19.6
1.029390	38.98	---	56.00	17.02	N	OFF	19.6
1.055940	---	28.90	46.00	17.10	N	OFF	19.6
1.055940	37.30	---	56.00	18.70	N	OFF	19.6
1.144500	---	28.26	46.00	17.74	N	OFF	19.6
1.144500	38.73	---	56.00	17.27	N	OFF	19.6
1.268250	---	23.27	46.00	22.73	N	OFF	19.6
1.268250	27.52	---	56.00	28.48	N	OFF	19.6
1.484250	---	23.38	46.00	22.62	N	OFF	19.6
1.484250	25.48	---	56.00	30.52	N	OFF	19.6
4.465500	---	25.21	46.00	20.79	N	OFF	19.8
4.465500	27.93	---	56.00	28.07	N	OFF	19.8
15.336330	---	25.58	50.00	24.42	N	OFF	20.2
15.336330	27.93	---	60.00	32.07	N	OFF	20.2



Appendix C. Radiated Spurious Emission

Test Engineer :	Jesse Wang, Stan Hsieh and Ken Wu	Temperature :	21~23°C
		Relative Humidity :	50~57%

Band 4 - 5725~5850MHz

WIFI 802.11a (Band Edge @ 3m)

WIFI	Note	Frequency	Level	Over	Limit	Read	Antenna	Path	Preamp	Ant	Table	Peak	Pol.	
Ant.				Limit	Line	Level	Factor	Loss	Factor	Pos	Pos	Avg.		
4+3		(MHz)	(dBμV/m)	(dB)	(dBμV/m)	(dBμV)	(dB/m)	(dB)	(dB)	(cm)	(deg)	(P/A)	(H/V)	
802.11a CH 149 5745MHz		5607.6	48.98	-19.22	68.2	37.24	35	12.05	35.31	100	9	P	H	
		5697.2	54.8	-48.34	103.14	42.92	35	12.2	35.32	100	9	P	H	
		5717.8	65.17	-45.01	110.18	53.26	35	12.23	35.32	100	9	P	H	
		5724.6	70.24	-51.05	121.29	58.31	35	12.25	35.32	100	9	P	H	
	*	5745	115.2	-	-	103.24	35	12.28	35.32	100	9	P	H	
	*	5745	106.9	-	-	94.94	35	12.28	35.32	100	9	A	H	
														H
														H
			5631.8	48	-20.2	68.2	36.32	34.9	12.09	35.31	315	238	P	V
			5687.8	49.56	-46.64	96.2	37.7	35	12.18	35.32	315	238	P	V
			5717.8	58.9	-51.28	110.18	46.99	35	12.23	35.32	315	238	P	V
			5723.4	65.13	-53.42	118.55	53.21	35	12.24	35.32	315	238	P	V
	*		5745	110.19	-	-	98.23	35	12.28	35.32	315	238	P	V
	*		5745	103.34	-	-	91.38	35	12.28	35.32	315	238	A	V
													V	
													V	



WIFI Ant. 4+3	Note	Frequency (MHz)	Level (dBμV/m)	Over Limit (dB)	Limit Line (dBμV/m)	Read Level (dBμV)	Antenna Factor (dB/m)	Path Loss (dB)	Preamp Factor (dB)	Ant Pos (cm)	Table Pos (deg)	Peak Avg. (P/A)	Pol. (H/V)
		5623.6	48.63	-19.57	68.2	36.96	34.9	12.08	35.31	108	9	P	H
		5684.6	49.15	-44.69	93.84	37.29	35	12.18	35.32	108	9	P	H
		5717	52.32	-57.64	109.96	40.41	35	12.23	35.32	108	9	P	H
		5721	50.91	-62.17	113.08	38.99	35	12.24	35.32	108	9	P	H
	*	5785	114.5	-	-	102.48	35	12.35	35.33	108	9	P	H
	*	5785	106.36	-	-	94.34	35	12.35	35.33	108	9	A	H
		5851.8	52.2	-65.9	118.1	40.14	35	12.4	35.34	108	9	P	H
		5855.2	51.01	-59.73	110.74	38.88	35.07	12.4	35.34	108	9	P	H
		5877.2	51.01	-52.56	103.57	38.81	35.13	12.41	35.34	108	9	P	H
		5934.6	49.74	-18.46	68.2	37.44	35.2	12.44	35.34	108	9	P	H
													H
													H
802.11a													
CH 157													
5785MHz		5604.2	48.63	-19.57	68.2	36.89	35	12.05	35.31	295	238	P	V
		5691	50.32	-48.24	98.56	38.45	35	12.19	35.32	295	238	P	V
		5704	48.15	-58.17	106.32	36.26	35	12.21	35.32	295	238	P	V
		5725	48.18	-74.02	122.2	36.25	35	12.25	35.32	295	238	P	V
	*	5785	108.85	-	-	96.83	35	12.35	35.33	295	238	P	V
	*	5785	101.96	-	-	89.94	35	12.35	35.33	295	238	A	V
		5852.8	49.09	-66.73	115.82	37.03	35	12.4	35.34	295	238	P	V
		5870.8	49.67	-56.7	106.37	37.47	35.13	12.41	35.34	295	238	P	V
		5901.2	49.71	-36.06	85.77	37.43	35.2	12.42	35.34	295	238	P	V
		5948.6	49.63	-18.57	68.2	37.33	35.2	12.44	35.34	295	238	P	V
													V
													V



WiFi Ant. 4+3	Note	Frequency (MHz)	Level (dBµV/m)	Over Limit (dB)	Limit Line (dBµV/m)	Read Level (dBµV)	Antenna Factor (dB/m)	Path Loss (dB)	Preamp Factor (dB)	Ant Pos (cm)	Table Pos (deg)	Peak Avg. (P/A)	Pol. (H/V)	
802.11a CH 165 5825MHz	*	5825	113.88	-	-	101.83	35	12.38	35.33	100	9	P	H	
	*	5825	106.14	-	-	94.09	35	12.38	35.33	100	9	A	H	
		5853.2	58.1	-56.8	114.9	46.04	35	12.4	35.34	100	9	P	H	
		5855	57.11	-53.69	110.8	44.98	35.07	12.4	35.34	100	9	P	H	
		5875.8	53.85	-50.76	104.61	41.65	35.13	12.41	35.34	100	9	P	H	
		5936.6	50.87	-17.33	68.2	38.57	35.2	12.44	35.34	100	9	P	H	
														H
														H
	*	5825	110.6	-	-	98.55	35	12.38	35.33	299	65	P	V	
	*	5825	102.69	-	-	90.64	35	12.38	35.33	299	65	A	V	
		5853.6	53.96	-60.03	113.99	41.83	35.07	12.4	35.34	299	65	P	V	
		5857.6	51.43	-58.64	110.07	39.3	35.07	12.4	35.34	299	65	P	V	
		5914.2	50.54	-25.63	76.17	38.25	35.2	12.43	35.34	299	65	P	V	
		5925.2	51.51	-16.69	68.2	39.22	35.2	12.43	35.34	299	65	P	V	
														V
														V
													V	
Remark	<ol style="list-style-type: none"> No other spurious found. All results are PASS against Peak and Average limit line. 													



Band 4 5725~5850MHz

WIFI 802.11a (Harmonic @ 3m)

WIFI Ant. 4+3	Note	Frequency (MHz)	Level (dBμV/m)	Over Limit (dB)	Limit Line (dBμV/m)	Read Level (dBμV)	Antenna Factor (dB/m)	Path Loss (dB)	Preamp Factor (dB)	Ant Pos (cm)	Table Pos (deg)	Peak Avg. (P/A)	Pol. (H/V)	
802.11a CH 149 5745MHz		11490	54.72	-19.28	74	55.58	38.18	18.48	57.52	400	294	P	H	
		11490	45.54	-8.46	54	46.4	38.18	18.48	57.52	400	294	A	H	
		17235	50.12	-18.08	68.2	41.95	41.53	22.95	56.31	100	0	P	H	
													H	
		11490	58.35	-15.65	74	59.21	38.18	18.48	57.52	100	336	P	V	
		11490	49.28	-4.72	54	50.14	38.18	18.48	57.52	100	336	A	V	
		17235	51.06	-17.14	68.2	42.89	41.53	22.95	56.31	100	0	P	V	
														V
802.11a CH 157 5785MHz		11570	49.56	-24.44	74	50.02	38.33	18.55	57.34	100	0	P	H	
		17355	50.42	-17.78	68.2	42.25	41.5	23.02	56.35	100	0	P	H	
													H	
													H	
		11570	57.35	-16.65	74	57.81	38.33	18.55	57.34	100	336	P	V	
		11570	49.66	-4.34	54	50.12	38.33	18.55	57.34	100	336	A	V	
		17355	50.32	-17.88	68.2	42.15	41.5	21.18	56.35	100	0	P	V	
														V
802.11a CH 165 5825MHz		11650	49.65	-24.35	74	49.73	38.44	18.63	57.15	100	0	P	H	
		17475	49.59	-18.61	68.2	41.55	41.33	23.09	56.38	100	0	P	H	
													H	
													H	
		11650	57.82	-16.18	74	57.9	38.44	18.63	57.15	100	334	P	V	
		11650	49.12	-4.88	54	49.2	38.44	18.63	57.15	100	334	A	V	
														V
														V
Remark	1. No other spurious found. 2. All results are PASS against Peak and Average limit line.													



Band 4 5725~5850MHz

WIFI 802.11n HT20 (Band Edge @ 3m)

WIFI Ant. 4+3	Note	Frequency (MHz)	Level (dBμV/m)	Over Limit (dB)	Limit Line (dBμV/m)	Read Level (dBμV)	Antenna Factor (dB/m)	Path Loss (dB)	Preamp Factor (dB)	Ant Pos (cm)	Table Pos (deg)	Peak Avg. (P/A)	Pol. (H/V)	
802.11n HT20 CH 149 5745MHz		5619.4	49.24	-18.96	68.2	37.58	34.9	12.07	35.31	100	10	P	H	
		5699.6	53.97	-50.94	104.91	42.09	35	12.2	35.32	100	10	P	H	
		5719.6	68.24	-42.45	110.69	56.32	35	12.24	35.32	100	10	P	H	
		5722.2	76.54	-39.28	115.82	64.62	35	12.24	35.32	100	10	P	H	
	*	5745	115.28	-	-	103.32	35	12.28	35.32	100	10	P	H	
	*	5745	107.24	-	-	95.28	35	12.28	35.32	100	10	A	H	
														H
														H
			5625.2	48.24	-19.96	68.2	36.57	34.9	12.08	35.31	315	238	P	V
			5696.6	49.38	-53.31	102.69	37.5	35	12.2	35.32	315	238	P	V
			5719.4	61.6	-49.03	110.63	49.68	35	12.24	35.32	315	238	P	V
			5725	69.44	-52.76	122.2	57.51	35	12.25	35.32	315	238	P	V
	*		5745	111.11	-	-	99.15	35	12.28	35.32	315	238	P	V
	*		5745	103.88	-	-	91.92	35	12.28	35.32	315	238	A	V
														V
														V



WIFI Ant. 4+3	Note	Frequency (MHz)	Level (dBμV/m)	Over Limit (dB)	Limit Line (dBμV/m)	Read Level (dBμV)	Antenna Factor (dB/m)	Path Loss (dB)	Preamp Factor (dB)	Ant Pos (cm)	Table Pos (deg)	Peak Avg. (P/A)	Pol. (H/V)
		5619.4	48.63	-19.57	68.2	36.97	34.9	12.07	35.31	101	9	P	H
		5682	48.94	-42.98	91.92	37.23	34.85	12.18	35.32	101	9	P	H
		5713.4	50.6	-58.35	108.95	38.69	35	12.23	35.32	101	9	P	H
		5721.6	52.74	-61.71	114.45	40.82	35	12.24	35.32	101	9	P	H
	*	5785	113.25	-	-	101.23	35	12.35	35.33	101	9	P	H
	*	5785	105.88	-	-	93.86	35	12.35	35.33	101	9	A	H
		5854	54.62	-58.46	113.08	42.49	35.07	12.4	35.34	101	9	P	H
		5858.8	52.19	-57.54	109.73	40.06	35.07	12.4	35.34	101	9	P	H
		5916.6	51.45	-22.94	74.39	39.16	35.2	12.43	35.34	101	9	P	H
		5949.8	50.8	-17.4	68.2	38.5	35.2	12.44	35.34	101	9	P	H
802.11n													H
HT20													H
CH 157		5611.6	49.43	-18.77	68.2	37.68	35	12.06	35.31	297	237	P	V
5785MHz		5651.6	49.1	-20.29	69.39	37.59	34.7	12.13	35.32	297	237	P	V
		5701.8	48.2	-57.5	105.7	36.31	35	12.21	35.32	297	237	P	V
		5722.6	49.13	-67.6	116.73	37.21	35	12.24	35.32	297	237	P	V
	*	5785	109	-	-	96.98	35	12.35	35.33	297	237	P	V
	*	5785	101.96	-	-	89.94	35	12.35	35.33	297	237	A	V
		5854	49.33	-63.75	113.08	37.2	35.07	12.4	35.34	297	237	P	V
		5874	49.37	-56.11	105.48	37.17	35.13	12.41	35.34	297	237	P	V
		5887.4	50.76	-45.23	95.99	38.56	35.13	12.41	35.34	297	237	P	V
		5926	50.28	-17.92	68.2	37.99	35.2	12.43	35.34	297	237	P	V
													V
													V



WIFI Ant. 4+3	Note	Frequency (MHz)	Level (dBμV/m)	Over Limit (dB)	Limit Line (dBμV/m)	Read Level (dBμV)	Antenna Factor (dB/m)	Path Loss (dB)	Preamp Factor (dB)	Ant Pos (cm)	Table Pos (deg)	Peak Avg. (P/A)	Pol. (H/V)	
802.11n HT20 CH 165 5825MHz	*	5825	113.44	-	-	101.39	35	12.38	35.33	100	9	P	H	
	*	5825	105.71	-	-	93.66	35	12.38	35.33	100	9	A	H	
		5850	63.39	-58.81	122.2	51.32	35	12.4	35.33	100	9	P	H	
		5856.4	57.16	-53.25	110.41	45.03	35.07	12.4	35.34	100	9	P	H	
		5878	53.69	-49.28	102.97	41.49	35.13	12.41	35.34	100	9	P	H	
		5930.6	51.65	-16.55	68.2	39.35	35.2	12.44	35.34	100	9	P	H	
														H
														H
	*	5825	110.74	-	-	98.69	35	12.38	35.33	299	65	P	V	
	*	5825	102.66	-	-	90.61	35	12.38	35.33	299	65	A	V	
		5851.2	56.72	-62.74	119.46	44.66	35	12.4	35.34	299	65	P	V	
		5855.6	50.27	-60.36	110.63	38.14	35.07	12.4	35.34	299	65	P	V	
		5893.6	50.14	-41.26	91.4	37.86	35.2	12.42	35.34	299	65	P	V	
		5939.8	49.97	-18.23	68.2	37.67	35.2	12.44	35.34	299	65	P	V	
														V
													V	
Remark	1. No other spurious found. 2. All results are PASS against Peak and Average limit line.													



Band 4 5725~5850MHz

WIFI 802.11n HT20 (Harmonic @ 3m)

WIFI Ant. 4+3	Note	Frequency (MHz)	Level (dBμV/m)	Over Limit (dB)	Limit Line (dBμV/m)	Read Level (dBμV)	Antenna Factor (dB/m)	Path Loss (dB)	Preamp Factor (dB)	Ant Pos (cm)	Table Pos (deg)	Peak Avg. (P/A)	Pol. (H/V)
802.11n HT20 CH 149 5745MHz		11490	54.72	-19.28	74	55.58	38.18	18.48	57.52	400	298	P	H
		11490	44.4	-9.6	54	45.26	38.18	18.48	57.52	400	298	A	H
		17235	49.63	-18.57	68.2	41.46	41.53	22.95	56.31	100	0	P	H
													H
		11490	58.75	-15.25	74	59.61	38.18	18.48	57.52	100	336	P	V
		11490	49.42	-4.58	54	50.28	38.18	18.48	57.52	100	336	A	V
		17235	49.88	-18.32	68.2	41.71	41.53	22.95	56.31	100	0	P	V
													V
802.11n HT20 CH 157 5785MHz		11570	49.62	-24.38	74	50.08	38.33	18.55	57.34	100	0	P	H
		17355	49.93	-18.27	68.2	41.76	41.5	23.02	56.35	100	0	P	H
													H
													H
		11570	56.51	-17.49	74	56.97	38.33	18.55	57.34	100	334	P	V
		11570	48.75	-5.25	54	49.21	38.33	18.55	57.34	100	334	A	V
		17355	49.63	-18.57	68.2	41.46	41.5	21.18	56.35	100	0	P	V
													V
802.11n HT20 CH 165 5825MHz		11650	53.22	-20.78	74	53.3	38.44	18.63	57.15	400	298	P	H
		11650	44.22	-9.78	54	44.3	38.44	18.63	57.15	400	298	A	H
		17475	49.08	-19.12	68.2	41.04	41.33	23.09	56.38	100	0	P	H
													H
		11650	57.61	-16.39	74	57.69	38.44	18.63	57.15	100	334	P	V
		11650	48.98	-5.02	54	49.06	38.44	18.63	57.15	100	334	A	V
		17475	50.25	-17.95	68.2	42.21	41.33	23.09	56.38	100	0	P	V
													V
Remark	1. No other spurious found. 2. All results are PASS against Peak and Average limit line.												



Band 4 5725~5850MHz

WIFI 802.11n HT40 (Band Edge @ 3m)

WIFI Ant. 4+3	Note	Frequency (MHz)	Level (dBμV/m)	Over Limit (dB)	Limit Line (dBμV/m)	Read Level (dBμV)	Antenna Factor (dB/m)	Path Loss (dB)	Preamp Factor (dB)	Ant Pos (cm)	Table Pos (deg)	Peak Avg. (P/A)	Pol. (H/V)
		5645.4	50.22	-17.98	68.2	38.62	34.8	12.11	35.31	100	9	P	H
		5699	61.46	-43	104.46	49.58	35	12.2	35.32	100	9	P	H
		5718.4	76.67	-33.68	110.35	64.75	35	12.24	35.32	100	9	P	H
		5723.2	76.17	-41.93	118.1	64.25	35	12.24	35.32	100	9	P	H
	*	5755	111.05	-	-	99.08	35	12.3	35.33	100	9	P	H
	*	5755	103.64	-	-	91.67	35	12.3	35.33	100	9	A	H
		5854	50.95	-62.13	113.08	38.82	35.07	12.4	35.34	100	9	P	H
		5856.8	53.4	-56.9	110.3	41.27	35.07	12.4	35.34	100	9	P	H
		5912.8	52.79	-24.41	77.2	40.5	35.2	12.43	35.34	100	9	P	H
		5943.8	49.87	-18.33	68.2	37.57	35.2	12.44	35.34	100	9	P	H
802.11n													H
HT40													H
CH 151		5636.2	48.81	-19.39	68.2	37.22	34.8	12.1	35.31	294	64	P	V
5755MHz		5699.8	55.1	-49.95	105.05	43.22	35	12.2	35.32	294	64	P	V
		5717.8	66.66	-43.52	110.18	54.75	35	12.23	35.32	294	64	P	V
		5724	68.54	-51.38	119.92	56.62	35	12.24	35.32	294	64	P	V
	*	5755	107.91	-	-	95.94	35	12.3	35.33	294	64	P	V
	*	5755	100.69	-	-	88.72	35	12.3	35.33	294	64	A	V
		5852.6	51.22	-65.05	116.27	39.16	35	12.4	35.34	294	64	P	V
		5862.8	50.68	-57.93	108.61	38.55	35.07	12.4	35.34	294	64	P	V
		5900	49.89	-36.77	86.66	37.61	35.2	12.42	35.34	294	64	P	V
		5941.2	50.47	-17.73	68.2	38.17	35.2	12.44	35.34	294	64	P	V
													V
													V



WIFI Ant. 4+3	Note	Frequency (MHz)	Level (dBμV/m)	Over Limit (dB)	Limit Line (dBμV/m)	Read Level (dBμV)	Antenna Factor (dB/m)	Path Loss (dB)	Preamp Factor (dB)	Ant Pos (cm)	Table Pos (deg)	Peak Avg. (P/A)	Pol. (H/V)
		5621	49.13	-19.07	68.2	37.47	34.9	12.07	35.31	102	9	P	H
		5690.8	50.85	-47.57	98.42	38.98	35	12.19	35.32	102	9	P	H
		5713.6	53.46	-55.55	109.01	41.55	35	12.23	35.32	102	9	P	H
		5724.6	54.21	-67.08	121.29	42.28	35	12.25	35.32	102	9	P	H
	*	5795	109.75	-	-	97.72	35	12.36	35.33	102	9	P	H
	*	5795	102.62	-	-	90.59	35	12.36	35.33	102	9	A	H
		5850.4	56.98	-64.31	121.29	44.92	35	12.4	35.34	102	9	P	H
		5864.8	54.91	-53.14	108.05	42.78	35.07	12.4	35.34	102	9	P	H
		5881.8	53.4	-46.75	100.15	41.2	35.13	12.41	35.34	102	9	P	H
		5931.6	50.37	-17.83	68.2	38.07	35.2	12.44	35.34	102	9	P	H
802.11n													H
HT40													H
CH 159		5644.6	49.1	-19.1	68.2	37.5	34.8	12.11	35.31	288	63	P	V
5795MHz		5692	49.59	-49.71	99.3	37.72	35	12.19	35.32	288	63	P	V
		5713	49.51	-59.33	108.84	37.6	35	12.23	35.32	288	63	P	V
		5724.6	48.21	-73.08	121.29	36.28	35	12.25	35.32	288	63	P	V
	*	5795	106.45	-	-	94.42	35	12.36	35.33	288	63	P	V
	*	5795	99.18	-	-	87.15	35	12.36	35.33	288	63	A	V
		5851.2	52.51	-66.95	119.46	40.45	35	12.4	35.34	288	63	P	V
		5855.2	51.35	-59.39	110.74	39.22	35.07	12.4	35.34	288	63	P	V
		5910	50.16	-29.11	79.27	37.87	35.2	12.43	35.34	288	63	P	V
		5948.8	51.03	-17.17	68.2	38.73	35.2	12.44	35.34	288	63	P	V
													V
													V
Remark	1. No other spurious found. 2. All results are PASS against Peak and Average limit line.												



Band 4 5725~5850MHz

WIFI 802.11n HT40 (Harmonic @ 3m)

WIFI Ant. 4+3	Note	Frequency (MHz)	Level (dBμV/m)	Over Limit (dB)	Limit Line (dBμV/m)	Read Level (dBμV)	Antenna Factor (dB/m)	Path Loss (dB)	Preamp Factor (dB)	Ant Pos (cm)	Table Pos (deg)	Peak Avg. (P/A)	Pol. (H/V)	
802.11n HT40 CH 151 5755MHz		11510	47.54	-26.46	74	48.31	38.2	18.51	57.48	100	0	P	H	
		17265	49.21	-18.99	68.2	41.1	41.47	22.96	56.32	100	0	P	H	
													H	
													H	
			11510	54.73	-19.27	74	55.5	38.2	18.51	57.48	100	335	P	V
			11510	45.32	-8.68	54	46.09	38.2	18.51	57.48	100	335	A	V
			17265	49.32	-18.88	68.2	41.21	41.47	21.12	56.32	100	0	P	V
														V
802.11n HT40 CH 159 5795MHz		11590	47.71	-26.29	74	48.06	38.37	18.57	57.29	100	0	P	H	
		17385	49.15	-19.05	68.2	40.9	41.57	23.04	56.36	100	0	P	H	
													H	
													H	
			11590	52.85	-21.15	74	53.2	38.37	18.57	57.29	100	334	P	V
			11590	44.72	-9.28	54	45.07	38.37	18.57	57.29	100	334	A	V
														V
														V
Remark	1. No other spurious found. 2. All results are PASS against Peak and Average limit line.													



Band 4 5725~5850MHz

WIFI 802.11ac VHT80 (Band Edge @ 3m)

WIFI Ant. 4+3	Note	Frequency (MHz)	Level (dBμV/m)	Over Limit (dB)	Limit Line (dBμV/m)	Read Level (dBμV)	Antenna Factor (dB/m)	Path Loss (dB)	Preamp Factor (dB)	Ant Pos (cm)	Table Pos (deg)	Peak Avg. (P/A)	Pol. (H/V)
		5646.6	54.56	-13.64	68.2	42.95	34.8	12.12	35.31	107	9	P	H
		5699.8	71.67	-33.38	105.05	59.79	35	12.2	35.32	107	9	P	H
		5719.6	73.83	-36.86	110.69	61.91	35	12.24	35.32	107	9	P	H
		5723.4	76.31	-42.24	118.55	64.39	35	12.24	35.32	107	9	P	H
	*	5775	106.94	-	-	94.94	35	12.33	35.33	107	9	P	H
	*	5775	100.11	-	-	88.11	35	12.33	35.33	107	9	A	H
		5853	72.25	-43.11	115.36	60.19	35	12.4	35.34	107	9	P	H
		5855.6	72.94	-37.69	110.63	60.81	35.07	12.4	35.34	107	9	P	H
		5879.4	65.57	-36.36	101.93	53.37	35.13	12.41	35.34	107	9	P	H
		5948.6	51.33	-16.87	68.2	39.03	35.2	12.44	35.34	107	9	P	H
802.11ac													H
VHT80													H
CH 155		5621.4	49.17	-19.03	68.2	37.5	34.9	12.08	35.31	352	62	P	V
5775MHz		5685.4	67.28	-27.15	94.43	55.42	35	12.18	35.32	352	62	P	V
		5702	65.29	-40.47	105.76	53.4	35	12.21	35.32	352	62	P	V
		5724	64.45	-55.47	119.92	52.53	35	12.24	35.32	352	62	P	V
	*	5775	103.85	-	-	91.85	35	12.33	35.33	352	62	P	V
	*	5775	96.61	-	-	84.61	35	12.33	35.33	352	62	A	V
		5855	56.99	-53.81	110.8	44.86	35.07	12.4	35.34	352	62	P	V
		5874.8	58.4	-46.86	105.26	46.2	35.13	12.41	35.34	352	62	P	V
		5877.4	57.46	-45.96	103.42	45.26	35.13	12.41	35.34	352	62	P	V
		5932.4	52.96	-15.24	68.2	40.66	35.2	12.44	35.34	352	62	P	V
													V
													V
Remark	1. No other spurious found. 2. All results are PASS against Peak and Average limit line.												



Band 4 5725~5850MHz

WIFI 802.11ac VHT80 (Harmonic @ 3m)

WIFI Ant. 4+3	Note	Frequency (MHz)	Level (dBμV/m)	Over Limit (dB)	Limit Line (dBμV/m)	Read Level (dBμV)	Antenna Factor (dB/m)	Path Loss (dB)	Preamp Factor (dB)	Ant Pos (cm)	Table Pos (deg)	Peak Avg. (P/A)	Pol. (H/V)	
802.11ac VHT80 CH 155 5775MHz		11550	46.88	-27.12	74	47.42	38.3	18.54	57.38	100	0	P	H	
		17325	49.83	-18.37	68.2	41.74	41.43	23	56.34	100	0	P	H	
													H	
													H	
			11550	51.63	-22.37	74	52.17	38.3	18.54	57.38	100	335	P	V
			11550	43.36	-10.64	54	43.9	38.3	18.54	57.38	100	335	A	V
			17325	49.71	-18.49	68.2	41.62	41.43	21.16	56.34	100	0	P	V
													V	
Remark	1. No other spurious found. 2. All results are PASS against Peak and Average limit line.													



Emission above 18GHz

WIFI 802.11a (SHF @ 3m)

WIFI	Note	Frequency	Level	Over	Limit	Read	Antenna	Path	Preamp	Ant	Table	Peak	Pol.	
Ant.				Limit	Line	Level	Factor	Loss	Factor	Pos	Pos	Avg.		
4+3		(MHz)	(dBμV/m)	(dB)	(dBμV/m)	(dBμV)	(dB/m)	(dB)	(dB)	(cm)	(deg)	(P/A)	(H/V)	
802.11a SHF		39802	44.53	-29.47	74	43.01	44.1	12.03	54.61	150	0	P	H	
													H	
													H	
													H	
													H	
													H	
														H
			39802	43.01	-30.99	74	41.28	44.31	12.03	54.61	150	0	P	V
														V
														V
														V
														V
														V
														V
Remark	1. No other spurious found. 2. All results are PASS against limit line.													



Emission below 1GHz

WIFI 802.11a (LF @ 3m)

WIFI	Note	Frequency	Level	Over	Limit	Read	Antenna	Path	Preamp	Ant	Table	Peak	Pol.	
Ant.				Limit	Line	Level	Factor	Loss	Factor	Pos	Pos	Avg.		
4+3		(MHz)	(dBμV/m)	(dB)	(dBμV/m)	(dBμV)	(dB/m)	(dB)	(dB)	(cm)	(deg)	(P/A)	(H/V)	
802.11a LF		31.62	26.29	-13.71	40	31.78	23.57	0.95	30.01	-	-	P	H	
		109.11	23.48	-20.02	43.5	34.85	16.85	1.75	29.97	-	-	P	H	
		169.05	29.47	-14.03	43.5	41.55	15.68	2.18	29.94	-	-	P	H	
		762	31.4	-14.6	46	28.44	27.8	4.69	29.53	-	-	P	H	
		883.1	33.54	-12.46	46	28.68	28.86	5.07	29.07	-	-	P	H	
		952.4	34.27	-11.73	46	27.32	30.37	5.27	28.69	100	0	P	H	
														H
														H
														H
														H
														H
														H
														H
			30	33.28	-6.72	40	38.04	24.32	0.93	30.01	100	0	P	V
			43.23	24.31	-15.69	40	36	17.2	1.11	30	-	-	P	V
			49.17	21.83	-18.17	40	35.85	14.78	1.19	29.99	-	-	P	V
			776	30.55	-15.45	46	27.62	27.68	4.75	29.5	-	-	P	V
			865.6	33.21	-12.79	46	28.48	28.87	5.01	29.15	-	-	P	V
			955.9	34.22	-11.78	46	27.11	30.5	5.28	28.67	-	-	P	V
														V
													V	
													V	
													V	
													V	
													V	
Remark	1. No other spurious found. 2. All results are PASS against limit line.													



Note symbol

*	Fundamental Frequency which can be ignored. However, the level of any unwanted emissions shall not exceed the level of the fundamental frequency.
!	Test result is over limit line.
P/A	Peak or Average
H/V	Horizontal or Vertical



A calculation example for radiated spurious emission is shown as below:

WIFI	Note	Frequency	Level	Over	Limit	Read	Antenna	Path	Preamp	Ant	Table	Peak	Pol.
Ant.				Limit	Line	Level	Factor	Loss	Factor	Pos	Pos	Avg.	
1+2		(MHz)	(dBμV/m)	(dB)	(dBμV/m)	(dBμV)	(dB/m)	(dB)	(dB)	(cm)	(deg)	(P/A)	(H/V)
802.11b		2390	55.45	-18.55	74	54.51	32.22	4.58	35.86	103	308	P	H
CH 01													
2412MHz		2390	43.54	-10.46	54	42.6	32.22	4.58	35.86	103	308	A	H

1. Path Loss(dB) = Cable loss(dB) + Filter loss(dB) + Attenuator loss(dB)
2. Level(dBμV/m) = Antenna Factor(dB/m) + Path Loss(dB) + Read Level(dBμV) - Preamp Factor(dB)
3. Over Limit(dB) = Level(dBμV/m) – Limit Line(dBμV/m)

For Peak Limit @ 2390MHz:

1. Level(dBμV/m)
= Antenna Factor(dB/m) + Path Loss(dB) + Read Level(dBμV) - Preamp Factor(dB)
= 32.22(dB/m) + 4.58(dB) + 54.51(dBμV) – 35.86 (dB)
= 55.45 (dBμV/m)
2. Over Limit(dB)
= Level(dBμV/m) – Limit Line(dBμV/m)
= 55.45(dBμV/m) – 74(dBμV/m)
= -18.55(dB)

For Average Limit @ 2390MHz:

1. Level(dBμV/m)
= Antenna Factor(dB/m) + Path Loss(dB) + Read Level(dBμV) - Preamp Factor(dB)
= 32.22(dB/m) + 4.58(dB) + 42.6(dBμV) – 35.86 (dB)
= 43.54 (dBμV/m)
2. Over Limit(dB) = Level(dBμV/m) – Limit Line(dBμV/m)
= 43.54(dBμV/m) – 54(dBμV/m)
= -10.46(dB)

Both peak and average measured complies with the limit line, so test result is “PASS”.



Appendix D. Radiated Spurious Emission Plots

Test Engineer :	Jesse Wang, Stan Hsieh and Ken Wu	Temperature :	21~23°C
		Relative Humidity :	50~57%

Band 4 - 5725~5850MHz
WIFI 802.11a (Band Edge @ 3m)

WIFI	Band 4 5725~5850MHz Band Edge @ 3m	
ANT	802.11a CH149 5745MHz	
4+3	Horizontal	Fundamental
Peak	<p> Site : 03CH07-HY Condition : PEAK_BE(B4)_16-24 3m HF_ANT_00075962 HORIZONTAL Detector : Peak Project : 022521-02 Mode : 34 </p>	<p> Site : 03CH07-HY Condition : PEAK(LNII) 3m HF_ANT_00075962 HORIZONTAL Detector : Peak Project : 022521-02 Mode : 34 </p>



WIFI	Band 4 5725~5850MHz Band Edge @ 3m	
ANT	802.11a CH149 5745MHz	
4+3	Vertical	Fundamental
Peak	<p>Site : ESCH07-RV Condition : PEAK_BE(B4)_16-24 Detector : Peak Project : 022521-02 Mode : 34</p>	<p>Site : ESCH07-RV Condition : PEAK(LIN)1 3m HF_ANT_00075962 VERTICAL Detector : Peak Project : 022521-02 Mode : 34</p>

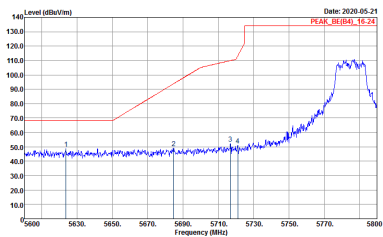
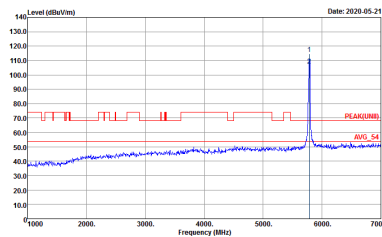
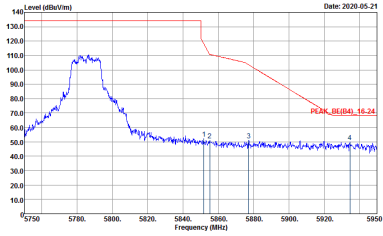

WIFI	Band 4 5725~5850MHz Band Edge @ 3m	
ANT	802.11a CH157 5785MHz	
4+3	Horizontal	Fundamental
Peak	 <p>Date: 2020-05-21 PEAK_BE(B4)_16-24</p> <p>Site : 03CH07-HY Condition : PEAK_BE(B4)_16-24 3m HF_ANT_00075962 HORIZONTAL Detector : Peak Project : 022521-02 Mode : 35</p>	 <p>Date: 2020-05-21 PEAK(B4)_16-24 AVG_24</p> <p>Site : 03CH07-HY Condition : PEAK(LIN) 3m HF_ANT_00075962 HORIZONTAL Detector : Peak Project : 022521-02 Mode : 35</p>
Peak	 <p>Date: 2020-05-21 PEAK_BE(B4)_16-24</p> <p>Site : 03CH07-HY Condition : PEAK_BE(B4)_16-24 3m HF_ANT_00075962 HORIZONTAL Detector : Peak Project : 022521-02 Mode : 35</p>	Left blank

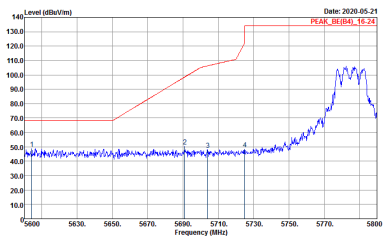
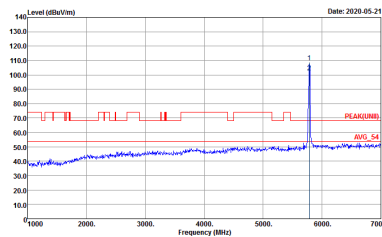
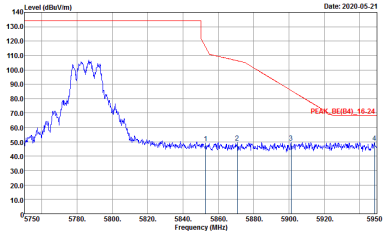

WIFI	Band 4 5725~5850MHz Band Edge @ 3m	
ANT	802.11a CH157 5785MHz	
4+3	Vertical	Fundamental
Peak	 <p>Date: 2020-05-21 PEAK_BE(B4)_16-24</p> <p>Site : 03CH07-HY Condition : PEAK_BE(B4)_16-24 3m HF_ANT_00075962 VERTICAL Detector : RBW:1000.000kHz VBW:3000.000kHz SWT:Auto Project : 022521-02 Mode : 35</p>	 <p>Date: 2020-05-21 PEAK(LNB) AVG_01</p> <p>Site : 03CH07-HY Condition : PEAK(LNB)_3m HF_ANT_00075962 VERTICAL Detector : RBW:1000.000kHz VBW:3000.000kHz SWT:Auto Project : 022521-02 Mode : 35</p>
Peak	 <p>Date: 2020-05-21 PEAK_BE(B4)_16-24</p> <p>Site : 03CH07-HY Condition : PEAK_BE(B4)_16-24 3m HF_ANT_00075962 VERTICAL Detector : RBW:1000.000kHz VBW:3000.000kHz SWT:Auto Project : 022521-02 Mode : 35</p>	Left blank



WIFI	Band 4 5725~5850MHz Band Edge @ 3m	
ANT	802.11a CH165 5825MHz	
4+3	Horizontal	Fundamental
Peak	<p>Site : ESCH07-RV Condition : PEAK_BE(B4) 16-24 3m HF_ANT_00075962 HORIZONTAL Detector : Peak Project : 022521-02 Mode : 36</p>	<p>Site : ESCH07-RV Condition : PEAK(LIN) 3m HF_ANT_00075962 HORIZONTAL Detector : Peak Project : 022521-02 Mode : 36</p>

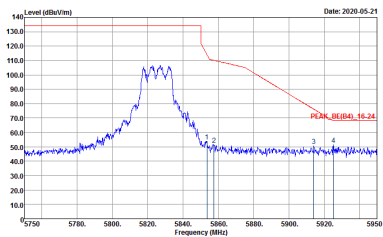
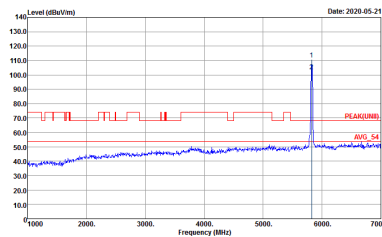

WIFI	Band 4 5725~5850MHz Band Edge @ 3m	
ANT	802.11a CH165 5825MHz	
4+3	Vertical	Fundamental
Peak	 <p>Date: 2020-05-21</p> <p>Site : ESCH07-RV Condition : PEAK_BE(B4) 16-24 3m HF_ANT_00075962 VERTICAL Detector : Peak Project : 022521-02 Mode : 36</p>	 <p>Date: 2020-05-21</p> <p>Site : ESCH07-RV Condition : PEAK(U1N1) 3m HF_ANT_00075962 VERTICAL Detector : Peak Project : 022521-02 Mode : 36</p>



**Band 4 5725~5850MHz
WIFI 802.11n HT20 (Band Edge @ 3m)**

WIFI	Band 4 5725~5850MHz Band Edge @ 3m	
ANT	802.11n HT20 CH149 5745MHz	
4+3	Horizontal	Fundamental
Peak	<p> Date: 2020-05-21 PEAK_BE(B4)_16.24 </p> <p> Site : 03CH07-HY Condition : PEAK_BE(B4)_16-24 3m HF_ANT_00075962 HORIZONTAL Detector : RBW:1000.000KHz VBW:3000.000KHz SWT:Auto Project : 022521-02 Mode : 37 </p>	<p> Date: 2020-05-21 PEAK(LIN)B AVG_54 </p> <p> Site : 03CH07-HY Condition : PEAK(LIN) 3m HF_ANT_00075962 HORIZONTAL Detector : RBW:1000.000KHz VBW:3000.000KHz SWT:Auto Project : 022521-02 Mode : 37 </p>



WIFI	Band 4 5725~5850MHz Band Edge @ 3m	
ANT	802.11n HT20 CH149 5745MHz	
4+3	Vertical	Fundamental
Peak	<p>Site : ESCH07-RY Condition : PEAK_BE(B4)_16-24 3m HF_ANT_00075962 VERTICAL Detector : RBW:1000.000kHz VBW:3000.000kHz SWT:Auto Project : 022521-02 Mode : 37</p>	<p>Site : ESCH07-RY Condition : PEAK(FUNB)_3m HF_ANT_00075962 VERTICAL Detector : RBW:1000.000kHz VBW:3000.000kHz SWT:Auto Project : 022521-02 Mode : 37</p>

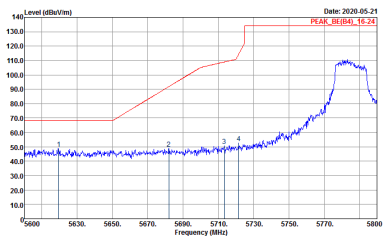
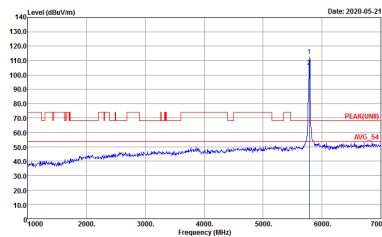
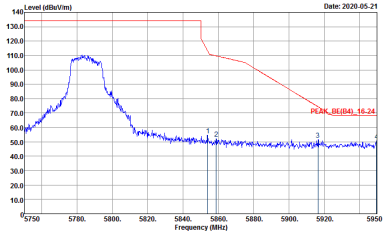

WIFI	Band 4 5725~5850MHz Band Edge @ 3m	
ANT	802.11n HT20 CH157 5785MHz	
4+3	Horizontal	Fundamental
<p>Peak</p>	 <p>Date: 2020-05-21 PEAK_BE(B4)_16-24</p> <p>Site : 03CH07-HY Condition : PEAK_BE(B4)_16-24 3m HF_ANT_00075962 HORIZONTAL Detector : Peak Project : 022521-02 Mode : 38</p>	 <p>Date: 2020-05-21 PEAK(B4)_16-24 AVG_24</p> <p>Site : 03CH07-HY Condition : PEAK(LUN1) 3m HF_ANT_00075962 HORIZONTAL Detector : Peak Project : 022521-02 Mode : 38</p>
<p>Peak</p>	 <p>Date: 2020-05-21 PEAK_BE(B4)_16-24</p> <p>Site : 03CH07-HY Condition : PEAK_BE(B4)_16-24 3m HF_ANT_00075962 HORIZONTAL Detector : Peak Project : 022521-02 Mode : 38</p>	<p>Left blank</p>



WIFI	Band 4 5725~5850MHz Band Edge @ 3m	
ANT	802.11n HT20 CH157 5785MHz	
4+3	Vertical	Fundamental
<p>Peak</p>	<p>Site : 03CH07-HY Condition : PEAK_BE(B4)_16-24 3m HF_ANT_00075962 VERTICAL Detector : Peak Project : 022521-02 Mode : 38</p>	<p>Site : 03CH07-HY Condition : PEAK(LIN) 3m HF_ANT_00075962 VERTICAL Detector : Peak Project : 022521-02 Mode : 38</p>
<p>Peak</p>	<p>Site : 03CH07-HY Condition : 03CH07-HY Detector : Peak Project : 022521-02 Mode : 38</p>	<p>Left blank</p>



WIFI	Band 4 5725~5850MHz Band Edge @ 3m	
ANT	802.11n HT20 CH165 5825MHz	
4+3	Horizontal	Fundamental
Peak	<p>Site : ESCH07-11Y Condition : PEAK_BE(B4) 16-24 3m HF_ANT_00075962 HORIZONTAL Detector : RBW:1000.000KHz VBW:3000.000KHz SWT:Auto Project : 022521-02 Mode : 39</p>	<p>Site : ESCH07-11Y Condition : PEAK(LIN) 3m HF_ANT_00075962 HORIZONTAL Detector : RBW:1000.000KHz VBW:3000.000KHz SWT:Auto Project : 022521-02 Mode : 39</p>



WIFI	Band 4 5725~5850MHz Band Edge @ 3m	
ANT	802.11n HT20 CH165 5825MHz	
4+3	Vertical	Fundamental
Peak	<p>Site : ESCH07-RV Condition : PEAK_BE(B4) 16-24 3m HF_ANT_00075962 VERTICAL Detector : Peak Project : 022521-02 Mode : 39</p>	<p>Site : ESCH07-RV Condition : PEAK(U/N1) 3m HF_ANT_00075962 VERTICAL Detector : Peak Project : 022521-02 Mode : 39</p>

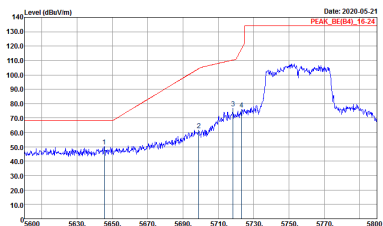
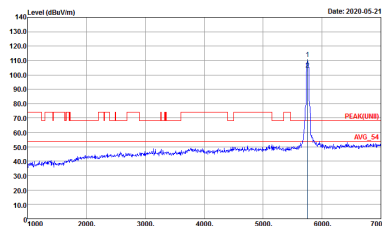
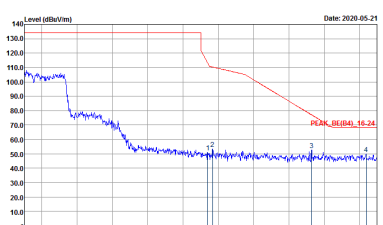

Band 4 5725~5850MHz
WIFI 802.11n HT40 (Band Edge @ 3m)

WIFI	Band 4 5725~5850MHz Band Edge @ 3m	
ANT	802.11n HT40 CH151 5755MHz	
4+3	Horizontal	Fundamental
Peak	 <p>Site : 03CH07-HY Condition : PEAK_BE(B4)_16-24 3m HF_ANT_00075962 HORIZONTAL Detector : RBW:1000.000kHz VBW:3000.000kHz SWT:Auto Project : 022521-02 Mode : 40</p>	 <p>Site : 03CH07-HY Condition : PEAK(LIN) 3m HF_ANT_00075962 HORIZONTAL Detector : RBW:1000.000kHz VBW:3000.000kHz SWT:Auto Project : 022521-02 Mode : 40</p>
Peak	 <p>Site : 03CH07-HY Condition : PEAK_BE(B4)_16-24 3m HF_ANT_00075962 HORIZONTAL Detector : RBW:1000.000kHz VBW:3000.000kHz SWT:Auto Project : 022521-02 Mode : 40</p>	Left blank

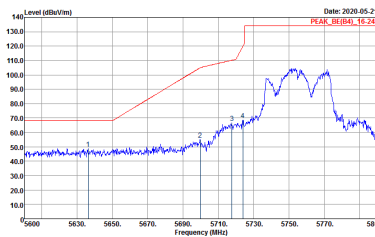
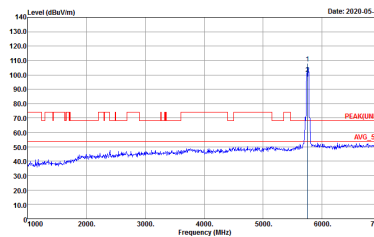
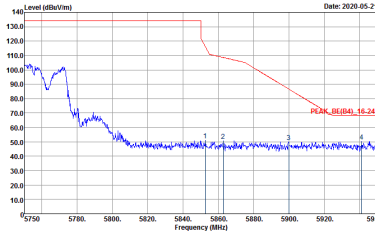

WIFI	Band 4 5725~5850MHz Band Edge @ 3m	
ANT	802.11n HT40 CH151 5755MHz	
4+3	Vertical	Fundamental
<p>Peak</p>	 <p>Date: 2020-05-21 PEAK_BE(B4)_16-24</p> <p>Site : 03CH07-HY Condition : PEAK_BE(B4)_16-24 3m HF_ANT_00075962 VERTICAL Detector : RBW:1000.000kHz VBW:3000.000kHz SWT:Auto Project : 022521-02 Mode : 40</p>	 <p>Date: 2020-05-21 PEAKLMBB AVG 51</p> <p>Site : 03CH07-HY Condition : PEAKLMBB 3m HF_ANT_00075962 VERTICAL Detector : RBW:1000.000kHz VBW:3000.000kHz SWT:Auto Project : 022521-02 Mode : 40</p>
<p>Peak</p>	 <p>Date: 2020-05-21 PEAK_BE(B4)_16-24</p> <p>Site : 03CH07-HY Condition : PEAK_BE(B4)_16-24 3m HF_ANT_00075962 VERTICAL Detector : RBW:1000.000kHz VBW:3000.000kHz SWT:Auto Project : 022521-02 Mode : 40</p>	<p>Left blank</p>





WIFI	Band 4 5725~5850MHz Band Edge @ 3m	
ANT	802.11n HT40 CH159 5795MHz	
4+3	Horizontal	Fundamental
<p>Peak</p>	<p>Date: 2020-05-21 PEAK_BE(B4)_16-24</p> <p>Site : 03CH07-HY Condition : PEAK_BE(B4)_16-24 3m HF_ANT_00075962 HORIZONTAL Detector : RBW:1000.000kHz VBW:3000.000kHz SWT:Auto Project : 022521-02 Mode : 41</p>	<p>Date: 2020-05-21 PEAK(FUNB) AVG_01</p> <p>Site : 03CH07-HY Condition : PEAK(FUNB)_3m HF_ANT_00075962 HORIZONTAL Detector : RBW:1000.000kHz VBW:3000.000kHz SWT:Auto Project : 022521-02 Mode : 41</p>
<p>Peak</p>	<p>Date: 2020-05-21 PEAK_BE(B4)_16-24</p> <p>Site : 03CH07-HY Condition : PEAK_BE(B4)_16-24 3m HF_ANT_00075962 HORIZONTAL Detector : RBW:1000.000kHz VBW:3000.000kHz SWT:Auto Project : 022521-02 Mode : 41</p>	<p>Left blank</p>

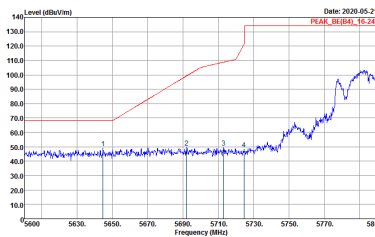
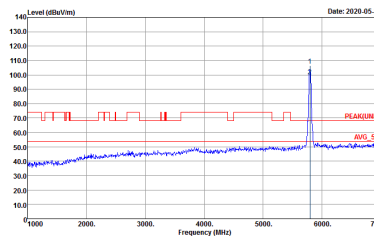
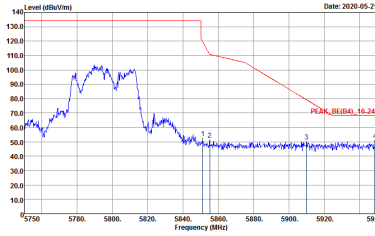

WIFI	Band 4 5725~5850MHz Band Edge @ 3m	
ANT	802.11n HT40 CH159 5795MHz	
4+3	Vertical	Fundamental
<p>Peak</p>	 <p>Site : 03CH07-HY Condition : PEAK_BE(B4)_16-24 3m HF_ANT_00075962 VERTICAL Detector : Peak Project : 022521-02 Mode : 41</p>	 <p>Site : 03CH07-HY Condition : PEAK(LN1) 3m HF_ANT_00075962 VERTICAL Detector : Peak Project : 022521-02 Mode : 41</p>
<p>Peak</p>	 <p>Site : 03CH07-HY Condition : PEAK_BE(B4)_16-24 3m HF_ANT_00075962 VERTICAL Detector : Peak Project : 022521-02 Mode : 41</p>	<p>Left blank</p>

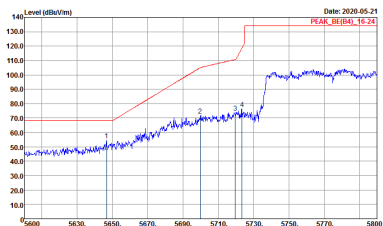
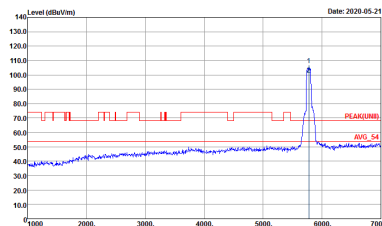

Band 4 5725~5850MHz
WIFI 802.11ac VHT80 (Band Edge @ 3m)

WIFI	Band 4 5725~5850MHz Band Edge @ 3m	
ANT	802.11ac VHT80 CH155 5775MHz	
4+3	Horizontal	Fundamental
Peak	 <p>Site : 03CH07-HY Condition : PEAK_BE(B4)_16-24 3m HF_ANT_00075962 HORIZONTAL Detector : RBW:1000.000kHz VBW:3000.000kHz SWT:Auto Project : 022521-02 Mode : 42</p>	 <p>Site : 03CH07-HY Condition : PEAK(LIN) 3m HF_ANT_00075962 HORIZONTAL Detector : RBW:1000.000kHz VBW:3000.000kHz SWT:Auto Project : 022521-02 Mode : 42</p>
Peak	 <p>Site : 03CH07-HY Condition : PEAK_BE(B4)_16-24 3m HF_ANT_00075962 HORIZONTAL Detector : RBW:1000.000kHz VBW:3000.000kHz SWT:Auto Project : 022521-02 Mode : 42</p>	Left blank

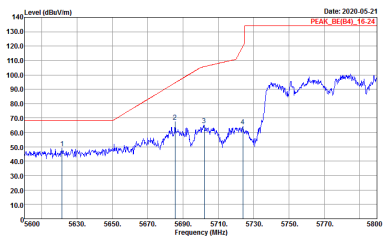
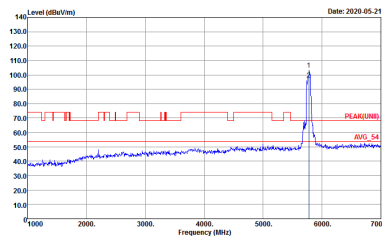
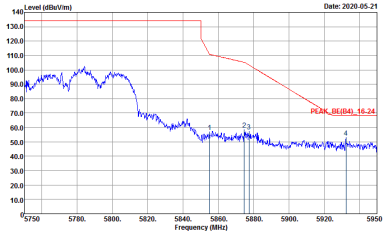

WIFI	Band 4 5725~5850MHz Band Edge @ 3m	
ANT	802.11ac VHT80 CH155 5775MHz	
4+3	Vertical	Fundamental
Peak	 <p>Date: 2020-05-21 PEAK_BE(B4)_16-24</p> <p>Site : 03CH07-HY Condition : PEAK_BE(B4)_16-24 3m HF_ANT_00075962 VERTICAL Detector : RBW:1000.000kHz VBW:3000.000kHz SWT:Auto Project : 022521-02 Mode : 42</p>	 <p>Date: 2020-05-21 PEAK(B4) AVG_01</p> <p>Site : 03CH07-HY Condition : PEAK(LIN) 3m HF_ANT_00075962 VERTICAL Detector : RBW:1000.000kHz VBW:3000.000kHz SWT:Auto Project : 022521-02 Mode : 42</p>
Peak	 <p>Date: 2020-05-21 PEAK_BE(B4)_16-24</p> <p>Site : 03CH07-HY Condition : PEAK_BE(B4)_16-24 3m HF_ANT_00075962 VERTICAL Detector : RBW:1000.000kHz VBW:3000.000kHz SWT:Auto Project : 022521-02 Mode : 42</p>	Left blank



Band 4 - 5725~5850MHz
WIFI 802.11a (Harmonic @ 3m)

WIFI	Band 4 5725~5850MHz Harmonic @ 3m	
ANT	802.11a CH149 5745MHz	
4+3	Horizontal	Vertical
Peak Avg.		



WIFI	Band 4 5725~5850MHz Harmonic @ 3m	
ANT	802.11a CH157 5785MHz	
4+3	Horizontal	Vertical
<p>Peak</p> <p>Avg.</p>		

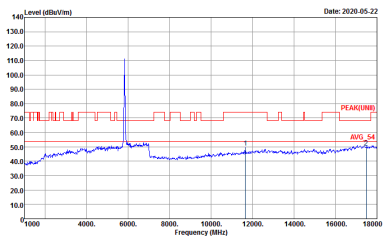
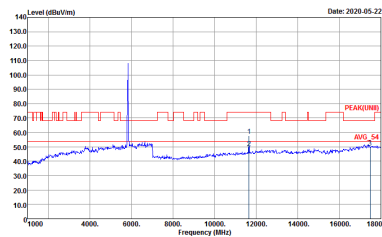

WIFI	Band 4 5725~5850MHz Harmonic @ 3m	
ANT	802.11a CH165 5825MHz	
4+3	Horizontal	Vertical
<p>Peak</p> <p>Avg.</p>	 <p>Site : E3CH07-RV Condition : PEAK(LIN) 3m HE_ANT_00075962 HORIZONTAL Detector : Peak Project : 022521-02 Mode : 36</p>	 <p>Site : E3CH07-RV Condition : PEAK(LIN) 3m HE_ANT_00075962 VERTICAL Detector : Peak Project : 022521-02 Mode : 36</p>



Band 4 5725~5850MHz
WIFI 802.11n HT20 (Harmonic @ 3m)

WIFI	Band 4 5725~5850MHz Harmonic @ 3m	
ANT	802.11n HT20 CH149 5745MHz	
4+3	Horizontal	Vertical
Peak Avg.		



WIFI	Band 4 5725~5850MHz Harmonic @ 3m	
ANT	802.11n HT20 CH157 5785MHz	
4+3	Horizontal	Vertical
Peak Avg.	<p>Site : ESCH07-RV Condition : PEAK(LIN) 3m HE_ANT_00075962 HORIZONTAL Detector : Peak Project : 022521-02 Mode : 38</p>	<p>Site : ESCH07-RV Condition : PEAK(LIN) 3m HE_ANT_00075962 VERTICAL Detector : Peak Project : 022521-02 Mode : 38</p>

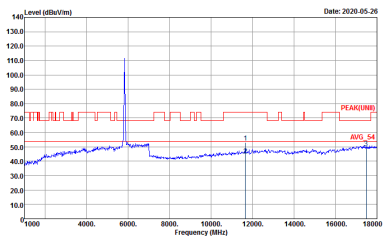
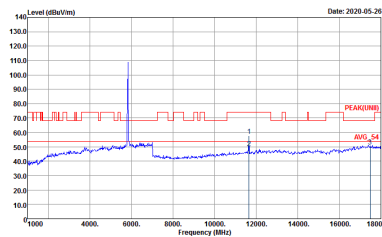

WIFI	Band 4 5725~5850MHz Harmonic @ 3m	
ANT	802.11n HT20 CH165 5825MHz	
4+3	Horizontal	Vertical
<p>Peak</p> <p>Avg.</p>	 <p>Site : ESCH07-RV Condition : PEAK(LIN) 3m HE_ANT_00075962 HORIZONTAL Detector : Peak Project : 022521-02 Mode : 39</p>	 <p>Site : ESCH07-RV Condition : PEAK(LIN) 3m HE_ANT_00075962 VERTICAL Detector : Peak Project : 022521-02 Mode : 39</p>



Band 4 5725~5850MHz
WIFI 802.11n HT40 (Harmonic @ 3m)

WIFI	Band 4 5725~5850MHz Harmonic @ 3m	
ANT	802.11n HT40 CH151 5755MHz	
4+3	Horizontal	Vertical
Peak Avg.		

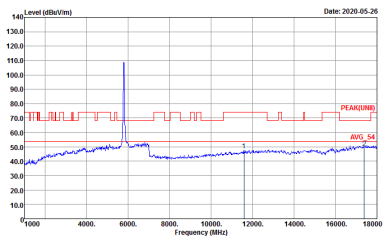
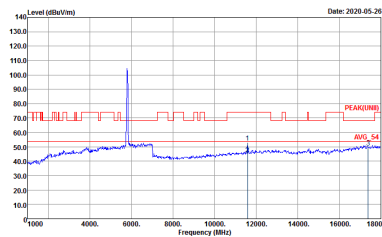

WIFI	Band 4 5725~5850MHz Harmonic @ 3m	
ANT	802.11n HT40 CH159 5795MHz	
4+3	Horizontal	Vertical
<p>Peak</p> <p>Avg.</p>	 <p>Site : ESCH07-RV Condition : PEAK(LIN) 3m HE_ANT_00075962 HORIZONTAL Detector : Peak Project : 022521-02 Mode : 41</p>	 <p>Site : ESCH07-RV Condition : PEAK(LIN) 3m HE_ANT_00075962 VERTICAL Detector : Peak Project : 022521-02 Mode : 41</p>



**Band 4 5725~5850MHz
WIFI 802.11ac VHT80 (Harmonic @ 3m)**

WIFI	Band 4 5725~5850MHz Harmonic @ 3m	
ANT	802.11ac VHT80 CH155 5775MHz	
4+3	Horizontal	Vertical
Peak Avg.	<p>Site : 03CH07-HY Condition : PEAK (UNII) 3m HF_ANT_00075962 HORIZONTAL Detector : Peak Project : 022521-02 Mode : 42</p>	<p>Site : 03CH07-HY Condition : PEAK (UNII) 3m HF_ANT_00075962 VERTICAL Detector : Peak Project : 022521-02 Mode : 42</p>



Emission above 18GHz

5GHz WIFI 802.11a (SHF)

WIFI	5GHz WIFI	
ANT	802.11a SHF	
4+3	Horizontal	Vertical
Peak Avg.	<p>Site : 03CH07-HY Condition : PEAK(LINE) 1m SHF-EHF_9170584 HORIZONTAL Detector : Peak Project : 022521-02 Mode : 49</p>	<p>Site : 03CH07-HY Condition : PEAK(LINE) 1m SHF-EHF_9170576 VERTICAL Detector : Peak Project : 022521-02 Mode : 49</p>



Emission below 1GHz

5GHz WIFI 802.11a (LF)

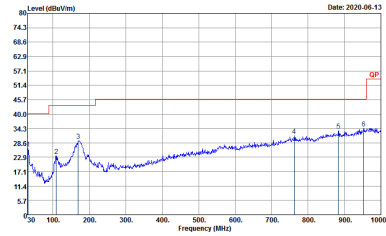
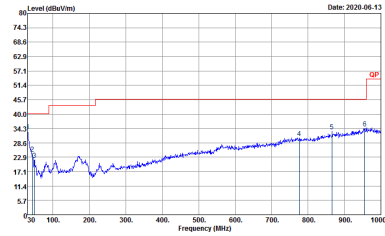
WIFI	5GHz WIFI	
ANT	802.11a LF	
4+3	Horizontal	Vertical
QP / Peak	 <p>Site : 03CH07-HY Condition : QP 3m LF-ANT-35419(G) HORIZONTAL Detector : Peak Project : 022521-02 Mode : 43</p>	 <p>Site : 03CH07-HY Condition : QP 3m LF-ANT-35419(G) VERTICAL Detector : Peak Project : 022521-02 Mode : 43</p>



Appendix E. Duty Cycle Plots

Antenna	Band	Duty Cycle(%)	T(us)	1/T(kHz)	VBW Setting	Duty Factor(dB)
4+3	802.11a for Ant. 4	97.88	2075	0.48	1kHz	0.09
4+3	802.11a for Ant. 3	97.87	2065	0.48	1kHz	0.09
4+3	5GHz 802.11n HT20 for Ant. 4	97.72	1925	0.52	1kHz	0.10
4+3	5GHz 802.11n HT20 for Ant. 3	97.96	1925	0.52	1kHz	0.09
4+3	5GHz 802.11n HT40 for Ant. 4	95.94	945	1.06	3kHz	0.18
4+3	5GHz 802.11n HT40 for Ant. 3	95.93	944	1.06	3kHz	0.18
4+3	5GHz 802.11ac VHT80 for Ant. 4	92.06	464	2.16	3kHz	0.36
4+3	5GHz 802.11ac VHT80 for Ant. 3	92.00	460	2.17	3kHz	0.36



MIMO <Ant. 4>

802.11a

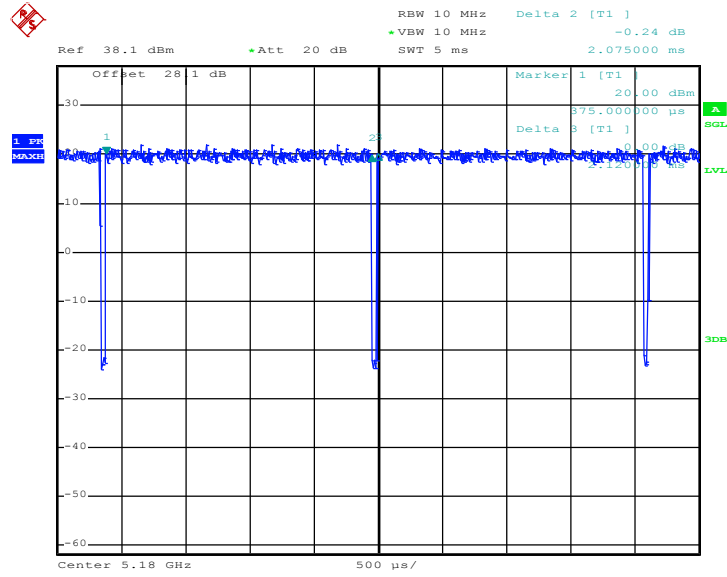

Date: 6.MAY.2020 17:10:02

802.11n HT20

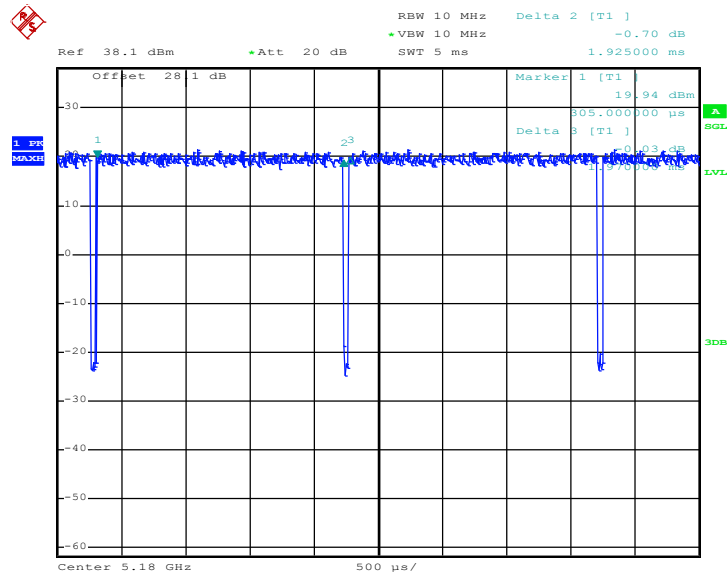

Date: 6.MAY.2020 17:13:04



802.11n HT40

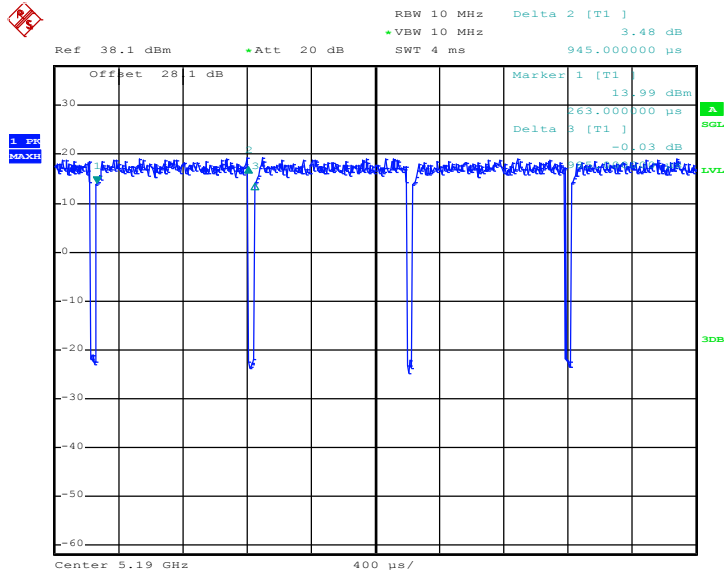

Date: 6.MAY.2020 17:19:45

802.11ac VHT80

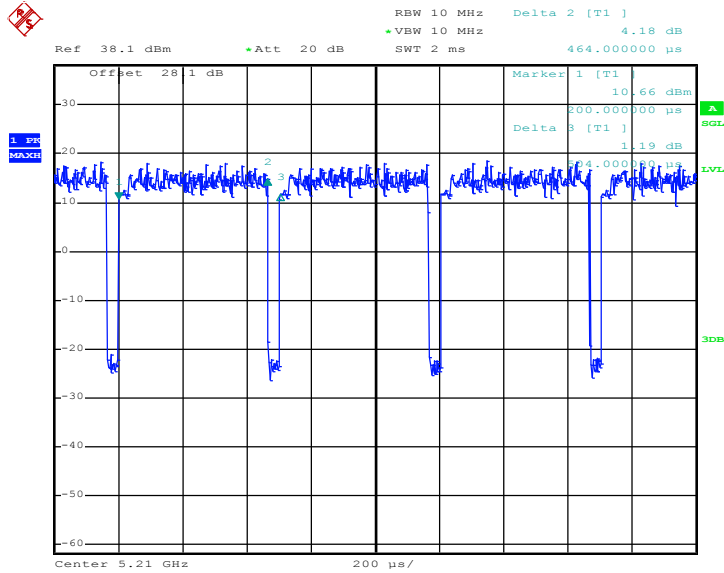

Date: 6.MAY.2020 17:29:04



MIMO<Ant. 3>

802.11a

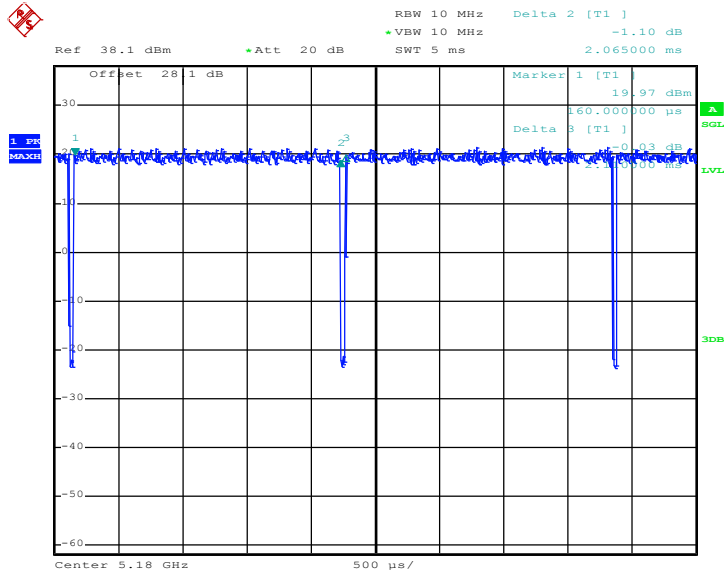

Date: 6.MAY.2020 17:11:18

802.11n HT20

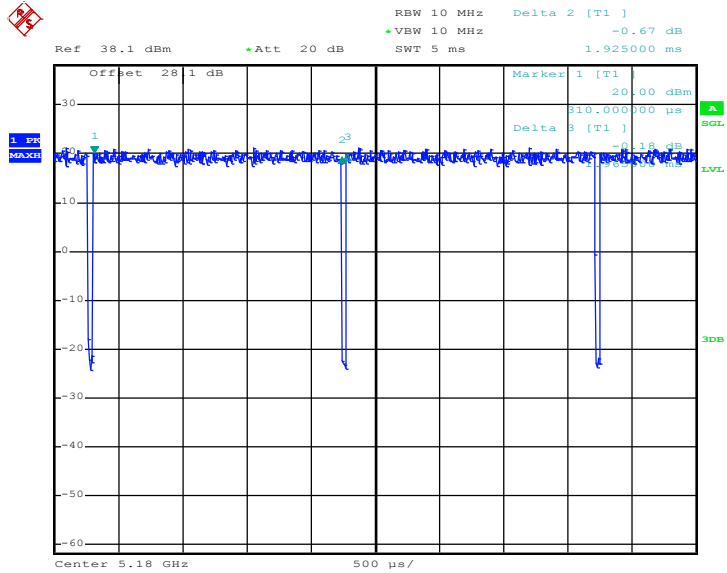

Date: 6.MAY.2020 17:14:53



802.11n HT40

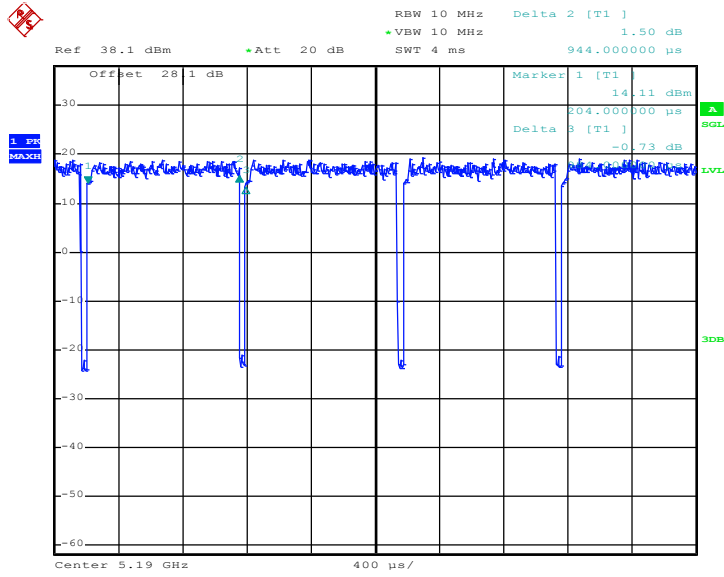

Date: 6.MAY.2020 17:20:44

802.11ac VHT80

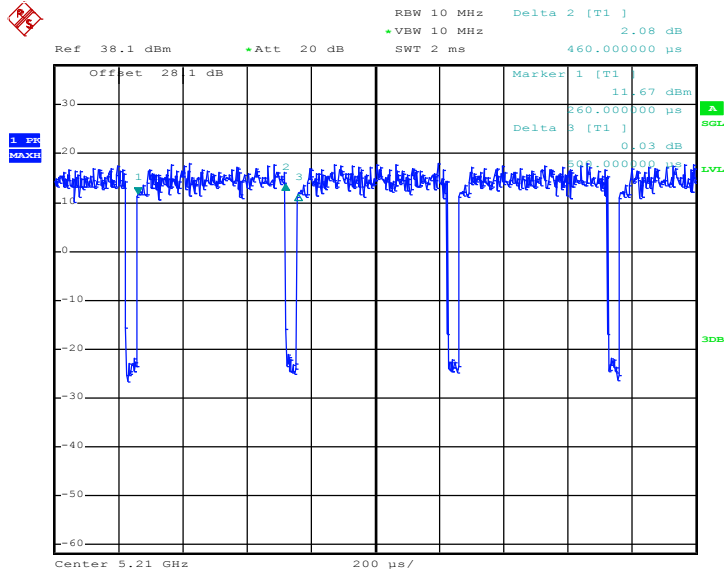

Date: 6.MAY.2020 17:30:03

—THE END—