



FCC RADIO TEST REPORT

FCC ID : A4RG025E
Equipment : Phone
Model Name : G025E
Applicant : Google LLC
1600 Amphitheatre Parkway,
Mountain View, California, 94043 USA
Standard : FCC Part 15 Subpart C §15.247

The product was received on Apr. 30, 2020 and testing was started from May 08, 2020 and completed on Jun. 26, 2020. We, SPORTON INTERNATIONAL INC., EMC & Wireless Communications Laboratory, would like to declare that the tested sample has been evaluated in accordance with the test procedures and has been in compliance with the applicable technical standards.

The test results in this report apply exclusively to the tested model / sample. Without written approval of SPORTON INTERNATIONAL INC. EMC & Wireless Communications Laboratory, the test report shall not be reproduced except in full.

Approved by: Louis Wu

SPORTON INTERNATIONAL INC. EMC & Wireless Communications Laboratory
No. 52, Huaya 1st Rd., Guishan Dist., Taoyuan City, Taiwan (R.O.C.)



Table of Contents

History of this test report.....	3
Summary of Test Result.....	4
1 General Description	5
1.1 Product Feature of Equipment Under Test.....	5
1.2 Modification of EUT	5
1.3 Testing Location	7
1.4 Applicable Standards.....	7
2 Test Configuration of Equipment Under Test	8
2.1 Carrier Frequency and Channel	8
2.2 Test Mode.....	9
2.3 Connection Diagram of Test System.....	10
2.4 Support Unit used in test configuration and system	11
2.5 EUT Operation Test Setup	11
2.6 Measurement Results Explanation Example.....	11
3 Test Result	12
3.1 6dB and 99% Bandwidth Measurement	12
3.2 Output Power Measurement.....	14
3.3 Power Spectral Density Measurement	15
3.4 Conducted Band Edges and Spurious Emission Measurement	17
3.5 Radiated Band Edges and Spurious Emission Measurement	36
3.6 AC Conducted Emission Measurement.....	41
3.7 Antenna Requirements	43
4 List of Measuring Equipment.....	44
5 Uncertainty of Evaluation	46
Appendix A. Conducted Test Results	
Appendix B. AC Conducted Emission Test Result	
Appendix C. Radiated Spurious Emission	
Appendix D. Radiated Spurious Emission Plots	
Appendix E. Duty Cycle Plots	



Summary of Test Result

Report Clause	Ref Std. Clause	Test Items	Result (PASS/FAIL)	Remark
3.1	15.247(a)(2)	6dB Bandwidth	Pass	-
3.1	2.1049	99% Occupied Bandwidth	Reporting only	-
3.2	15.247(b)	Power Output Measurement	Pass	-
3.3	15.247(e)	Power Spectral Density	Pass	-
3.4	15.247(d)	Conducted Band Edges	Pass	-
		Conducted Spurious Emission	Pass	-
3.5	15.247(d)	Radiated Band Edges and Radiated Spurious Emission	Pass	Under limit 1.95 dB at 2483.520 MHz
3.6	15.207	AC Conducted Emission	Pass	Under limit 7.12 dB at 0.966 MHz
3.7	15.203 & 15.247(b)	Antenna Requirement	Pass	-

Declaration of Conformity:
The test results with all measurement uncertainty excluded are presented in accordance with the regulation limits or requirements declared by manufacturers.
Comments and Explanations:
The declared of product specification for EUT presented in the report are provided by the manufacturer, and the manufacturer takes all the responsibilities for the accuracy of product specification.

Reviewed by: Wii Chang
Report Producer: Lucy Wu



1 General Description

1.1 Product Feature of Equipment Under Test

Product Feature	
Equipment	Phone
Model Name	G025E
FCC ID	A4RG025E
EUT supports Radios application	CDMA/EV-DO/GSM/EGPRS/WCDMA/HSPA/LTE/5G NR/ NFC/GNSS WLAN 11b/g/n HT20 WLAN 11a/n HT20/HT40 WLAN 11ac VHT20/VHT40/VHT80 Bluetooth BR/EDR/LE

Remark: The above EUT's information was declared by manufacturer.

EUT Information List	
S/N	Performed Test Item
04211FQCB00023	Conducted Measurement
04241FQCB00323	Radiated Spurious Emission
04241FQCB00291	Conducted Emission

1.2 Product Specification of Equipment Under Test

Standards-related Product Specification										
Tx/Rx Channel Frequency Range	2412 MHz ~ 2462 MHz									
Maximum (Average) Output Power to antenna	<p><Ant. 4> 802.11b : 19.30 dBm (0.0851 W) 802.11g : 19.20 dBm (0.0832 W) 802.11n HT20 : 19.30 dBm (0.0851 W) 802.11ac VHT20 : 19.20 dBm (0.0832 W)</p> <p><Ant. 3> 802.11b : 19.30 dBm (0.0851 W) 802.11g : 19.10 dBm (0.0813 W) 802.11n HT20 : 19.30 dBm (0.0851 W) 802.11ac VHT20 : 19.20 dBm (0.0832 W)</p> <p>MIMO <Ant. 4+3> 802.11b : 22.41 dBm (0.1742 W) 802.11g : 22.26 dBm (0.1683 W) 802.11n HT20 : 22.41 dBm (0.1742 W) 802.11ac VHT20 : 22.31 dBm (0.1702 W)</p>									
99% Occupied Bandwidth	<p>MIMO <Ant. 4> 802.11b : 14.20MHz 802.11g : 17.20MHz 802.11n HT20 : 18.30MHz</p> <p><MIMO <Ant. 3> 802.11b : 14.05MHz 802.11g : 17.05MHz 802.11n HT20 : 18.25MHz</p>									
Antenna Type / Gain	<p><Ant. 4> Monopole Antenna type with gain 0.40 dBi <Ant. 3> PIFA Antenna type with gain -0.30 dBi</p>									
Type of Modulation	802.11b : DSSS (DBPSK / DQPSK / CCK) 802.11g/n : OFDM (BPSK / QPSK / 16QAM / 64QAM) 802.11ac : OFDM (BPSK / QPSK / 16QAM / 64QAM / 256QAM)									
Antenna Function for Transmitter	<table border="1"> <thead> <tr> <th></th> <th>Ant. 4</th> <th>Ant. 3</th> </tr> </thead> <tbody> <tr> <td>802.11 b/g/n/ac</td> <td>V</td> <td>V</td> </tr> <tr> <td>802.11 b/g/n/ac MIMO</td> <td>V</td> <td>V</td> </tr> </tbody> </table>		Ant. 4	Ant. 3	802.11 b/g/n/ac	V	V	802.11 b/g/n/ac MIMO	V	V
	Ant. 4	Ant. 3								
802.11 b/g/n/ac	V	V								
802.11 b/g/n/ac MIMO	V	V								

Note: MIMO Ant. 4+3 is a calculated result from sum of the power MIMO Ant. 4 and MIMO Ant. 3.



1.3 Modification of EUT

No modifications are made to the EUT during all test items.

1.4 Testing Location

Test Site	SPORTON INTERNATIONAL INC. EMC & Wireless Communications Laboratory		
Test Site Location	No.52, Huaya 1st Rd., Guishan Dist., Taoyuan City, Taiwan (R.O.C.) TEL: +886-3-327-3456 FAX: +886-3-328-4978		
Test Site No.	Sporton Site No.		
	TH05-HY	CO05-HY	03CH07-HY

Note: The test site complies with ANSI C63.4 2014 requirement.

FCC designation No.: TW1190

1.5 Applicable Standards

According to the specifications of the manufacturer, the EUT must comply with the requirements of the following standards:

- ♦ FCC Part 15 Subpart C §15.247
- ♦ FCC KDB Publication No. 558074 D01 DTS Meas. Guidance v05r02
- ♦ FCC KDB 414788 D01 Radiated Test Site v01r01.
- ♦ FCC KDB 662911 D01 Multiple Transmitter Output v02r01.
- ♦ ANSI C63.10-2013

Remark:

1. All test items were verified and recorded according to the standards and without any deviation during the test.
2. The TAF code is not including all the FCC KDB listed without accreditation.
3. This EUT has also been tested and complied with the requirements of FCC Part 15, Subpart B, recorded in a separate test report.



2 Test Configuration of Equipment Under Test

- a. The EUT has been associated with peripherals and configuration operated in a manner tended to maximize its emission characteristics in a typical application. Frequency range investigated: conduction emission (150 kHz to 30 MHz), radiation emission (9 kHz to the 10th harmonic of the highest fundamental frequency or to 40 GHz, whichever is lower). For radiated measurement, pre-scanned in three orthogonal panels, X, Y, Z. The worst cases (X plane) were recorded in this report.

- b. AC power line Conducted Emission was tested under maximum output power.

2.1 Carrier Frequency and Channel

Frequency Band	Channel	Freq. (MHz)	Channel	Freq. (MHz)
2400-2483.5 MHz	1	2412	7	2442
	2	2417	8	2447
	3	2422	9	2452
	4	2427	10	2457
	5	2432	11	2462
	6	2437		



2.2 Test Mode

Final test modes are considering the modulation and worse data rates as below table.

Modulation	Data Rate
802.11b	1 Mbps
802.11g	6 Mbps
802.11n HT20	MCS0
802.11ac VHT20 (Covered by HT20)	MCS0

Test Cases	
AC Conducted Emission	Mode 1: GSM850 Idle + WLAN (2.4GHz) Link + Bluetooth Link + 3.5mm Headset + USB Cable 1 (Charging from AC Adapter 1)
Remark: For Radiated Test Cases, the tests were performed with Adapter 1 and USB Cable 1.	

Ch. #	2400-2483.5 MHz		
	802.11b	802.11g	802.11n HT20
Low	01	01	01
Middle	06	06	06
High	11	11	11

Remark: For radiation spurious emission, the final modulation and the worst data rate was reference the max RF conducted power.

2.3 Connection Diagram of Test System

<AC Conducted Emission Mode>

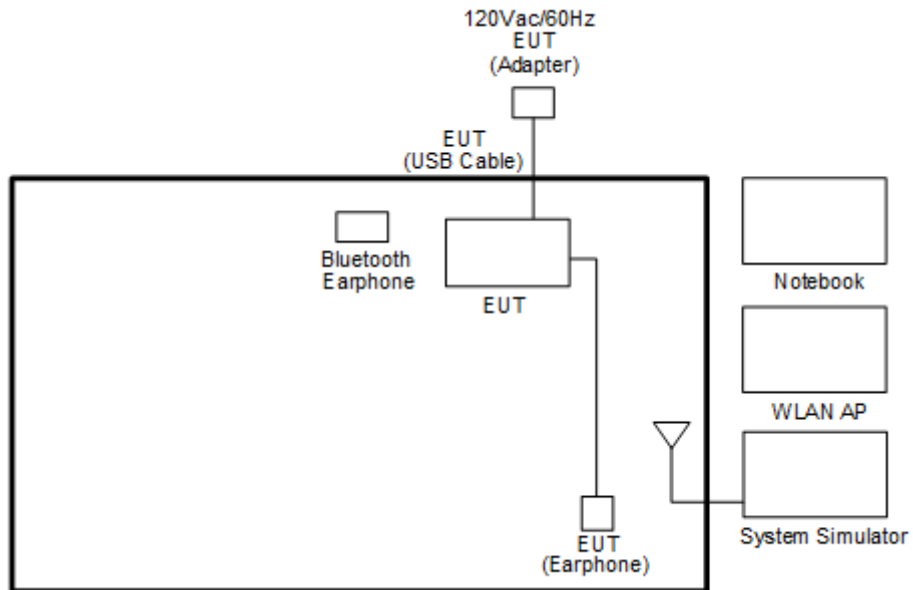

<WLAN Tx Mode>

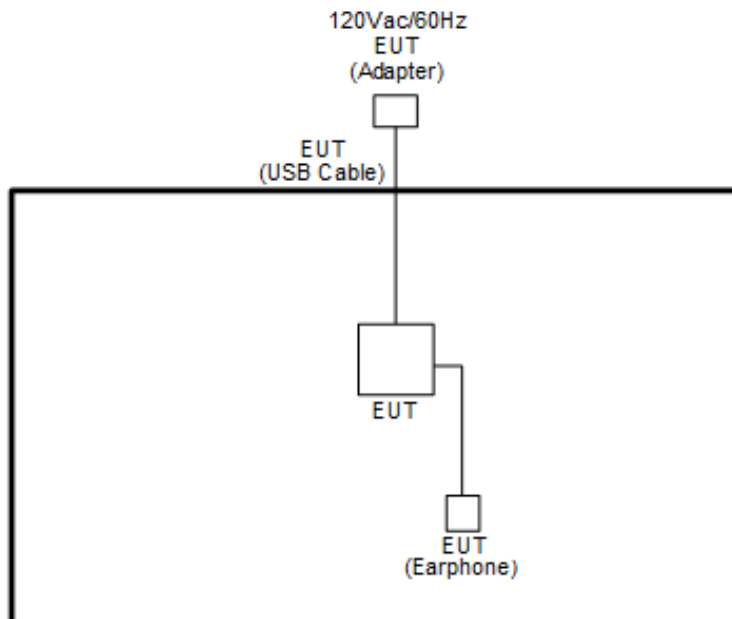



2.4 Support Unit used in test configuration and system

Item	Equipment	Trade Name	Model Name	FCC ID	Data Cable	Power Cord
1.	System Simulator	Anritsu	MT8820C	N/A	N/A	Unshielded, 1.8 m
2.	Bluetooth Earphone	Google	G015B	SZGG015B	N/A	N/A
3.	WLAN AP	ASUS	RT-AC66U	MSQ-RTAC66U	N/A	Unshielded, 1.8 m
4.	Notebook	DELL	Latitude 3400	FCC DoC	N/A	AC I/P: Unshielded, 1.2 m DC O/P: Shielded, 1.8 m
5.	Notebook	DELL	P79G	N/A	N/A	AC I/P: Unshielded, 1.2 m DC O/P: Shielded, 1.8 m

2.5 EUT Operation Test Setup

The RF test items, utility "QRCT4_V 4.0.00158.0" was installed in Notebook which was programmed in order to make the EUT get into the engineering modes to provide channel selection, power level, data rate and the application type and for continuous transmitting signals.

2.6 Measurement Results Explanation Example

For all conducted test items:

The offset level is set in the spectrum analyzer to compensate the RF cable loss and attenuator factor between EUT conducted output port and spectrum analyzer. With the offset compensation, the spectrum analyzer reading level is exactly the EUT RF output level.

Example:

The spectrum analyzer offset is derived from RF cable loss and attenuator factor.

Offset = RF cable loss + attenuator factor.

Following shows an offset computation example with cable loss 4.2 dB and 10dB attenuator.

Offset(dB) = RF cable loss(dB) + attenuator factor(dB).

= 4.2 + 10 = 14.2 (dB)

3 Test Result

3.1 6dB and 99% Bandwidth Measurement

3.1.1 Limit of 6dB and 99% Bandwidth

The minimum 6 dB bandwidth shall be at least 500 kHz.

3.1.2 Measuring Instruments

See list of measuring equipment of this test report.

3.1.3 Test Procedures

1. The testing follows the ANSI C63.10 Section 6.9.3 (OBW) and 11.8.1 (6dB BW).
2. The RF output of EUT was connected to the spectrum analyzer by RF cable and attenuator. The path loss was compensated to the results for each measurement.
3. Set to the maximum power setting and enable the EUT transmit continuously.
4. Make the measurement with the spectrum analyzer's resolution bandwidth (RBW) = 100 kHz. Set the Video bandwidth (VBW) = 300 kHz. In order to make an accurate measurement. The 6 dB bandwidth must be greater than 500 kHz.
5. For 99% Bandwidth Measurement, the spectrum analyzer's resolution bandwidth (RBW) is set 1-5% of the emission bandwidth and set the Video bandwidth (VBW) $\geq 3 * RBW$.
6. Measure and record the results in the test report.

3.1.4 Test Setup





3.1.5 Test Result of 6dB and 99% Occupied Bandwidth

Please refer to Appendix A.

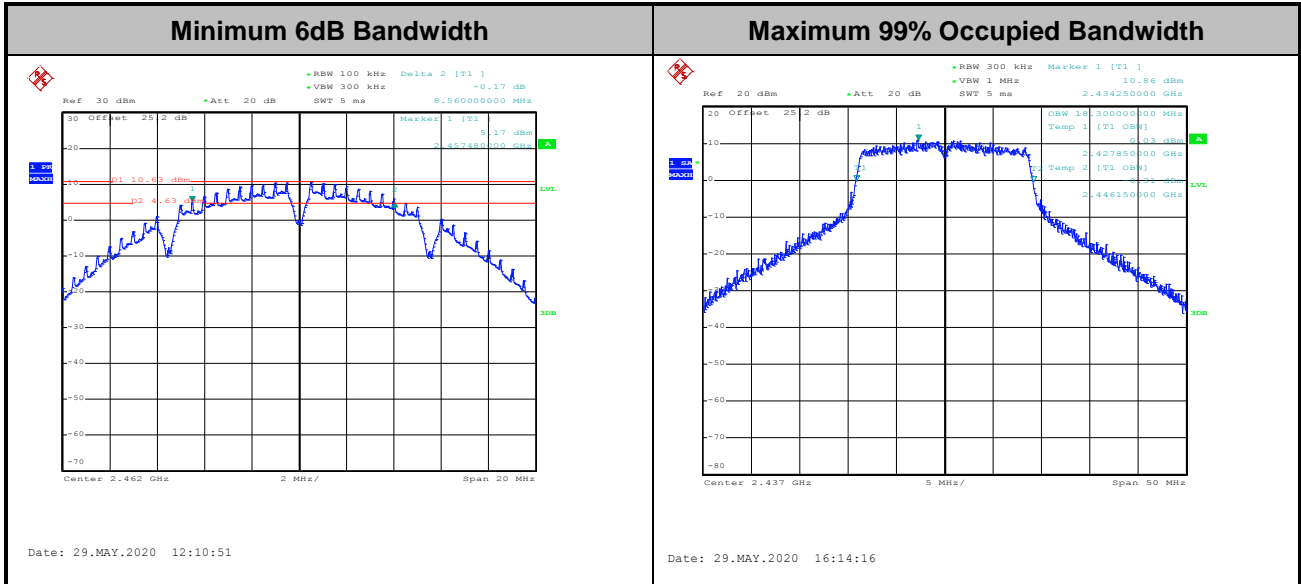

Note: The occupied channel bandwidth is maintained within the band of operation for all of the modulations.

3.2 Output Power Measurement

3.2.1 Limit of Output Power

For systems using digital modulation in the 2400-2483.5MHz, the limit for output power is 30dBm. If transmitting antenna with directional gain greater than 6dBi is used, the peak output power from the intentional radiator shall be reduced below the above stated value by the amount in dB that the directional gain of the antenna exceeds 6 dBi. In case of point-to-point operation, the limit has to be reduced by 1dB for every 3dB that the directional gain of the antenna exceeds 6dBi.

3.2.2 Measuring Instruments

See list of measuring equipment of this test report.

3.2.3 Test Procedures

1. For Average Power, the testing follows ANSI C63.10 Section 11.9.2.3.2 Method AVGPM-G
2. The RF output of EUT was connected to the power meter by RF cable and attenuator. The path loss was compensated to the results for each measurement.
3. Set to the maximum power setting and enable the EUT transmit continuously.
4. Measure the conducted output power and record the results in the test report.
5. For MIMO mode, calculation method follows FCC KDB 662911 D01 Multiple Transmitter Output v02r01.

3.2.4 Test Setup

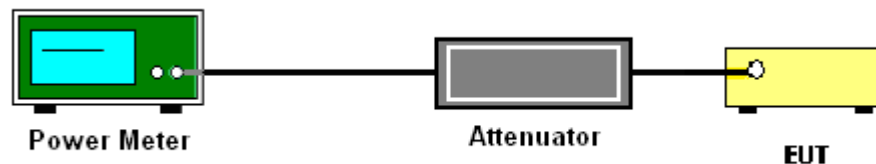

3.2.5 Test Result of Average Output Power

Please refer to Appendix A.

3.3 Power Spectral Density Measurement

3.3.1 Limit of Power Spectral Density

The peak power spectral density shall not be greater than 8dBm in any 3kHz band at any time interval of continuous transmission.

3.3.2 Measuring Instruments

See list of measuring equipment of this test report.

3.3.3 Test Procedures

1. The testing follows the ANSI C63.10 Section 11.10.2 Method PKPSD.
2. The RF output of EUT was connected to the spectrum analyzer by RF cable and attenuator. The path loss was compensated to the results for each measurement.
3. Set to the maximum power setting and enable the EUT transmit continuously.
4. Make the measurement with the spectrum analyzer's resolution bandwidth (RBW) = 3 kHz. Video bandwidth VBW = 10 kHz In order to make an accurate measurement, set the span to 1.5 times DTS Channel Bandwidth. (6dB BW)
5. Detector = peak, Sweep time = auto couple, Trace mode = max hold, Allow trace to fully stabilize. Use the peak marker function to determine the maximum power level.
6. Measure and record the results in the test report.
7. For MIMO mode, calculation method follows FCC KDB 662911 D01 Multiple Transmitter Output v02r01.

If measurements performed using method (2) plus $10 \log(N)$ exceeds the emission limit, the test should choose method (1) before declaring that the device fails the emission limit.

Method (1): Measure and sum the spectra across the outputs.

The total final Power Spectral Density is from a device with 2 transmitter outputs. The spectrum measurements of the individual outputs are all performed with the same span and number of points, the spectrum value in the first spectral bin of output 1 is summed with that in the first spectral bin of output 2 to obtain the value for the first frequency bin of the summed spectrum.

Method (2): Measure and add $10 \log(N)$ dB, where N is the number of outputs. (N=2)

3.3.4 Test Setup

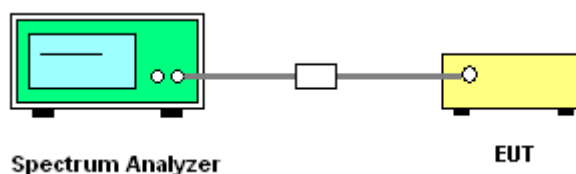



3.3.5 Test Result of Power Spectral Density

Please refer to Appendix A.

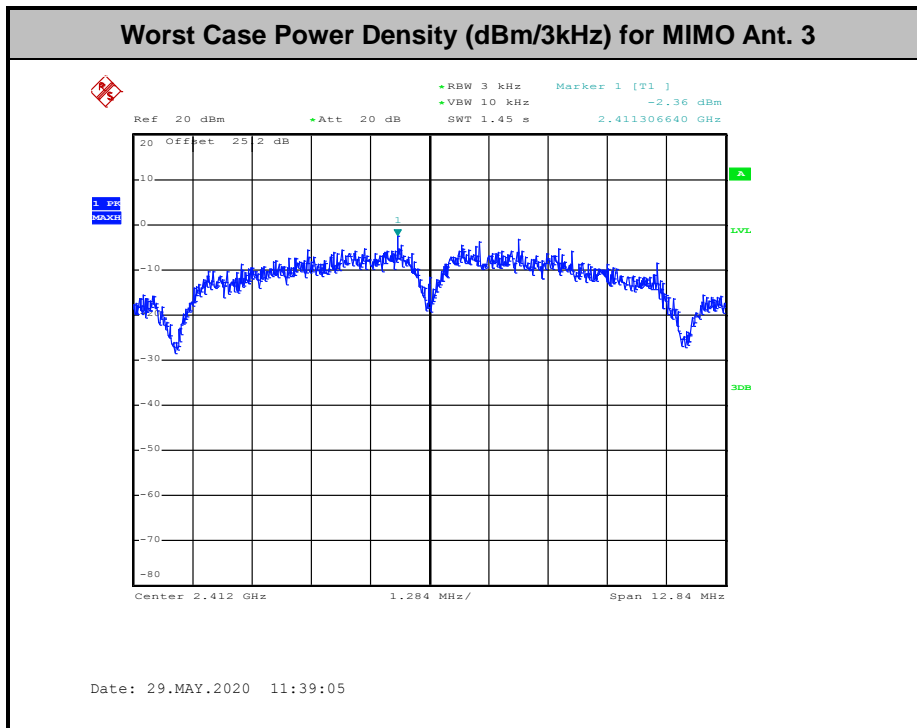
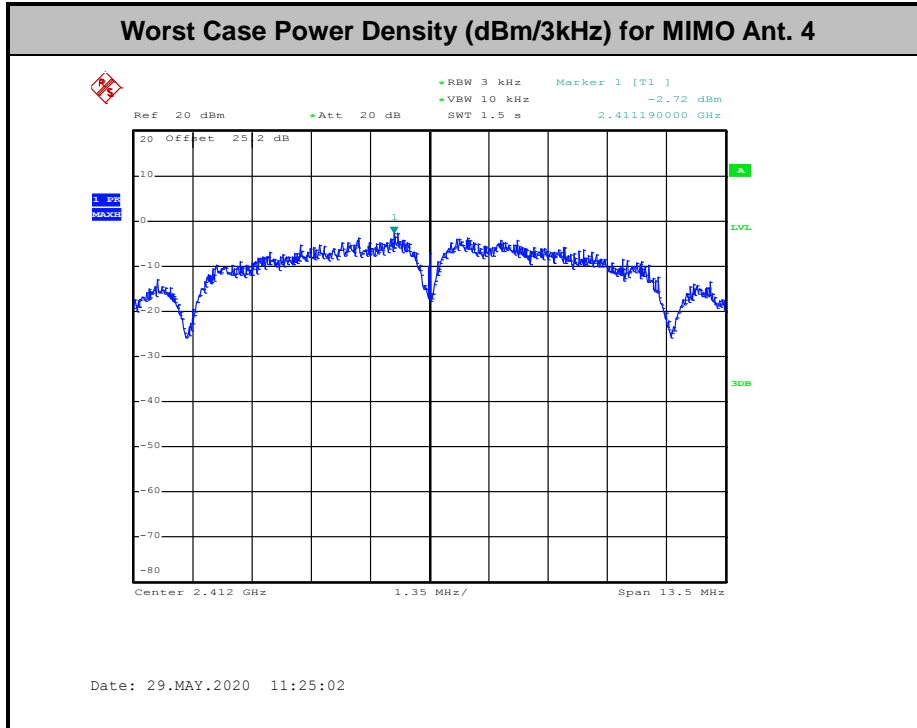

3.4 Conducted Band Edges and Spurious Emission Measurement

3.4.1 Limit of Conducted Band Edges and Spurious Emission Measurement

In any 100 kHz bandwidth outside of the authorized frequency band, the emissions which fall in the non-restricted bands shall be attenuated at least 20 dB / 30dB relative to the maximum PSD level in 100 kHz by RF conducted measurement.

3.4.2 Measuring Instruments

See list of measuring equipment of this test report.

3.4.3 Test Procedures

1. The testing follows the ANSI C63.10 Section 11.11.3 Emission level measurement.
2. The RF output of EUT was connected to the spectrum analyzer by RF cable and attenuator. The path loss was compensated to the results for each measurement.
3. Set to the maximum power setting and enable the EUT transmit continuously.
4. Set RBW = 100 kHz, VBW=300 kHz, Peak Detector. Unwanted Emissions measured in any 100 kHz bandwidth outside of the authorized frequency band shall be attenuated by at least 20 dB relative to the maximum in-band peak PSD level in 100 kHz when maximum peak conducted output power procedure is used. If the transmitter complies with the conducted power limits based on the use of RMS averaging over a time interval, the attenuation required under this paragraph shall be 30 dB instead of 20 dB per 15.247(d).
5. Measure and record the results in the test report.
6. The RF fundamental frequency should be excluded against the limit line in the operating frequency band.

3.4.4 Test Setup

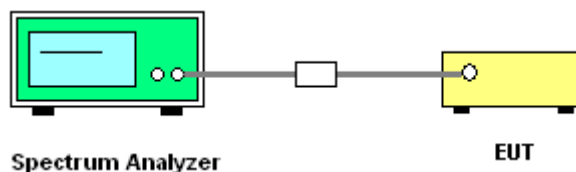



3.4.5 Test Result of Conducted Band Edges and Spurious Emission

Test Engineer :	Kathy Chen	Temperature :	20.1~22.2°C
		Relative Humidity :	45.7~58.8%

Number of TX = 2, Ant. 4 (Measured)

Test Mode :	802.11b	Test Channel :	01
-------------	---------	----------------	----

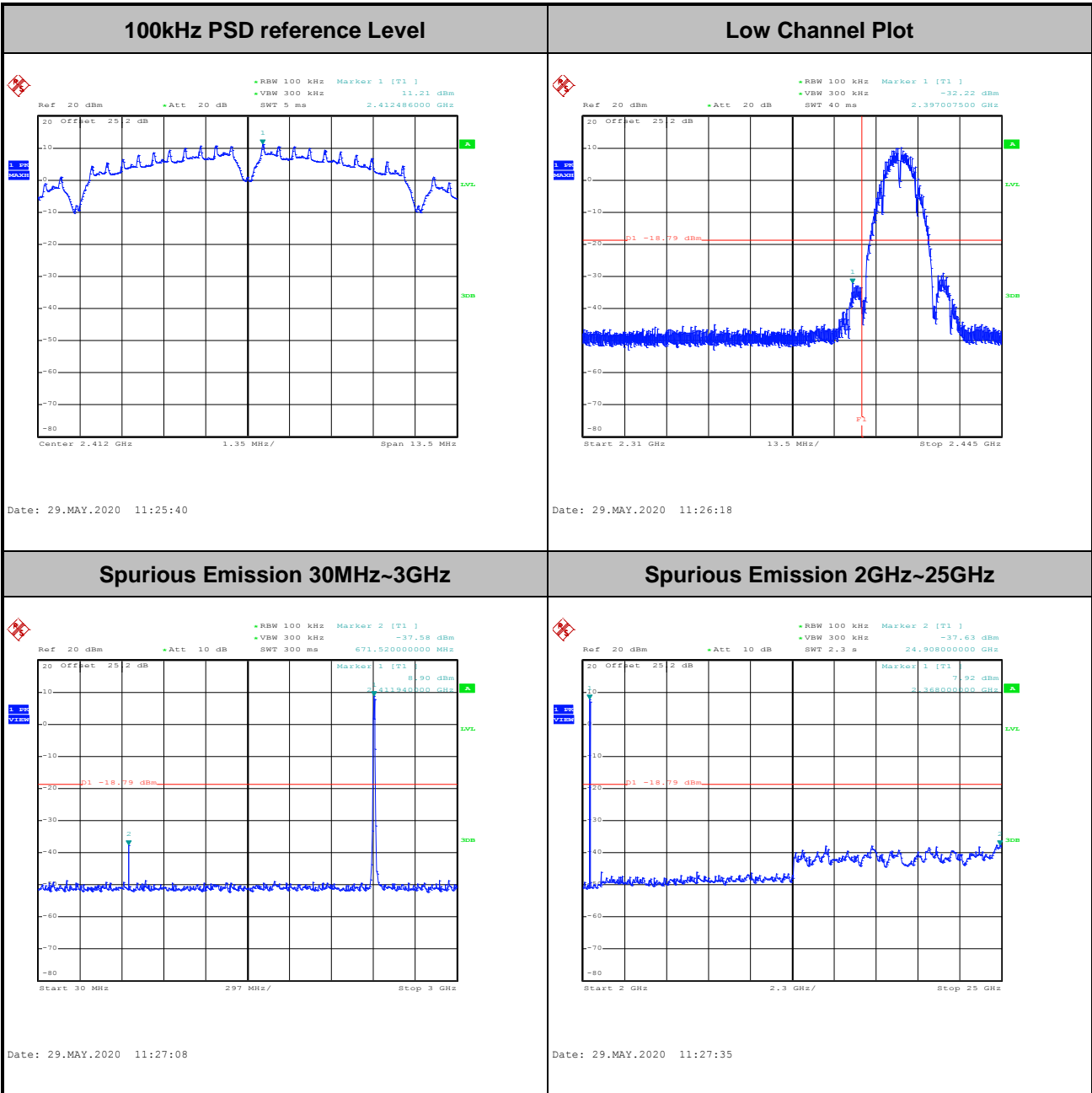



Test Mode :	802.11b	Test Channel :	06
-------------	---------	----------------	----

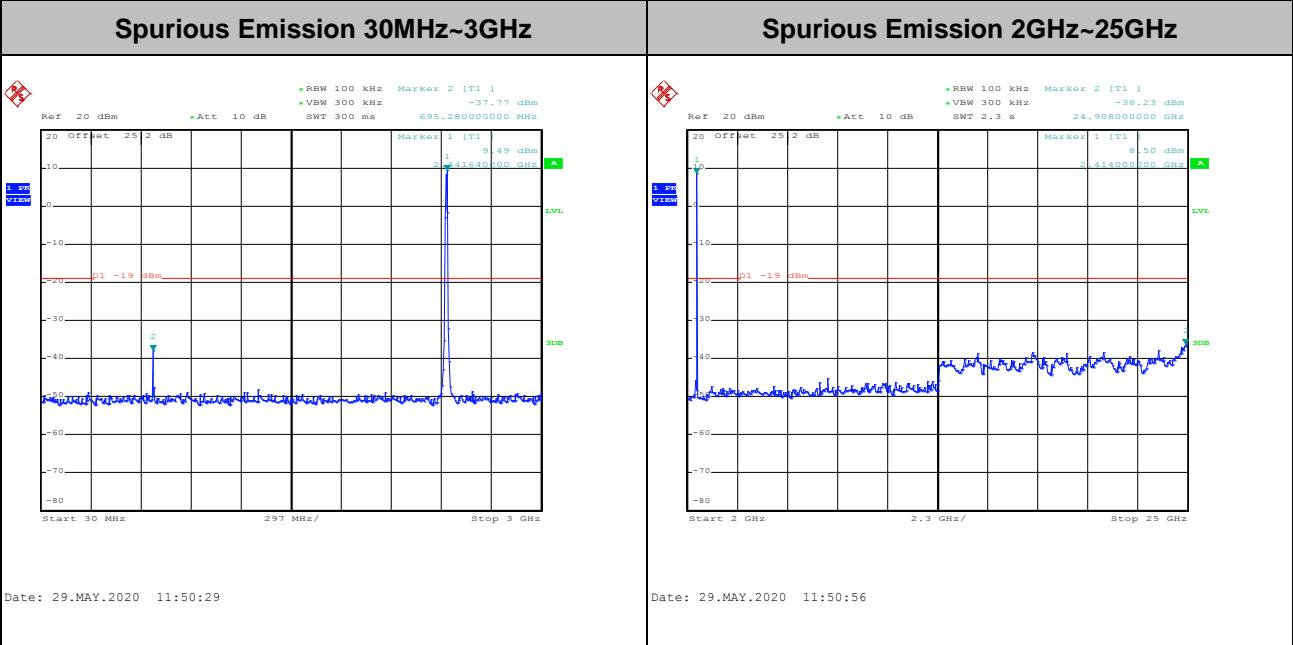
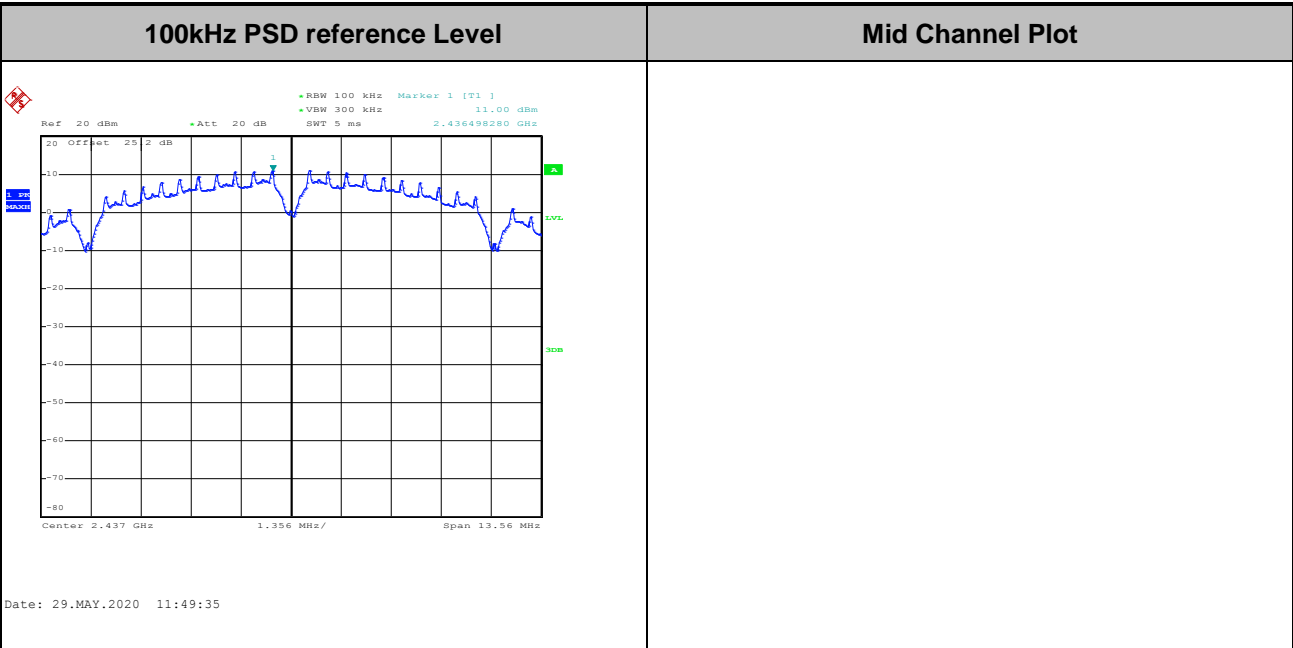



Test Mode :	802.11b	Test Channel :	11
-------------	---------	----------------	----

100kHz PSD reference Level	High Channel Plot
-----------------------------------	--------------------------

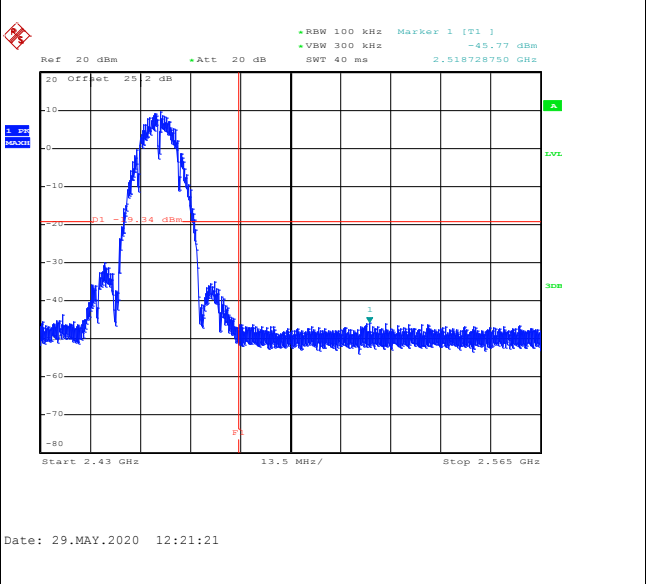
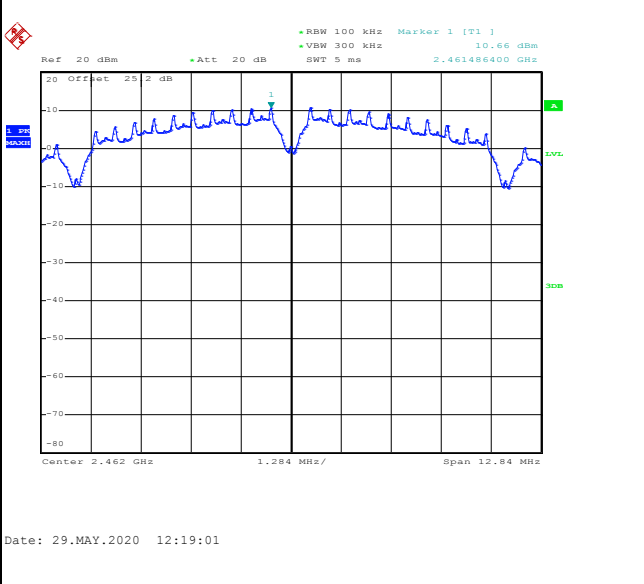

Spurious Emission 30MHz~3GHz	Spurious Emission 2GHz~25GHz
-------------------------------------	-------------------------------------

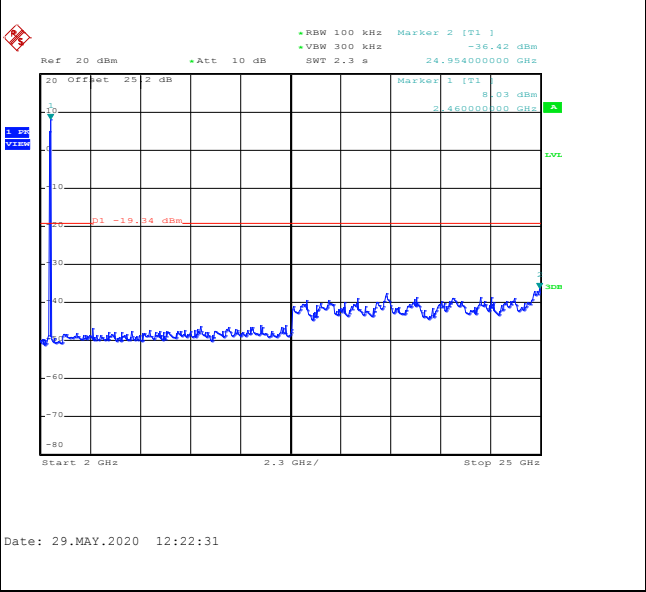
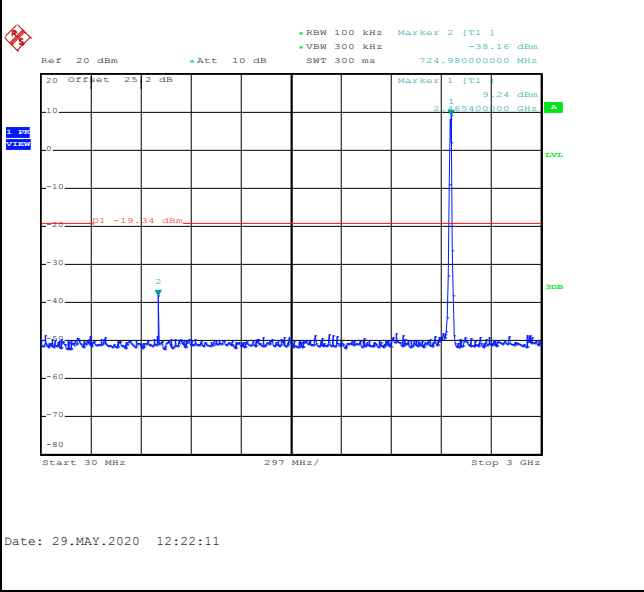



Test Mode :	802.11g	Test Channel :	01
-------------	---------	----------------	----

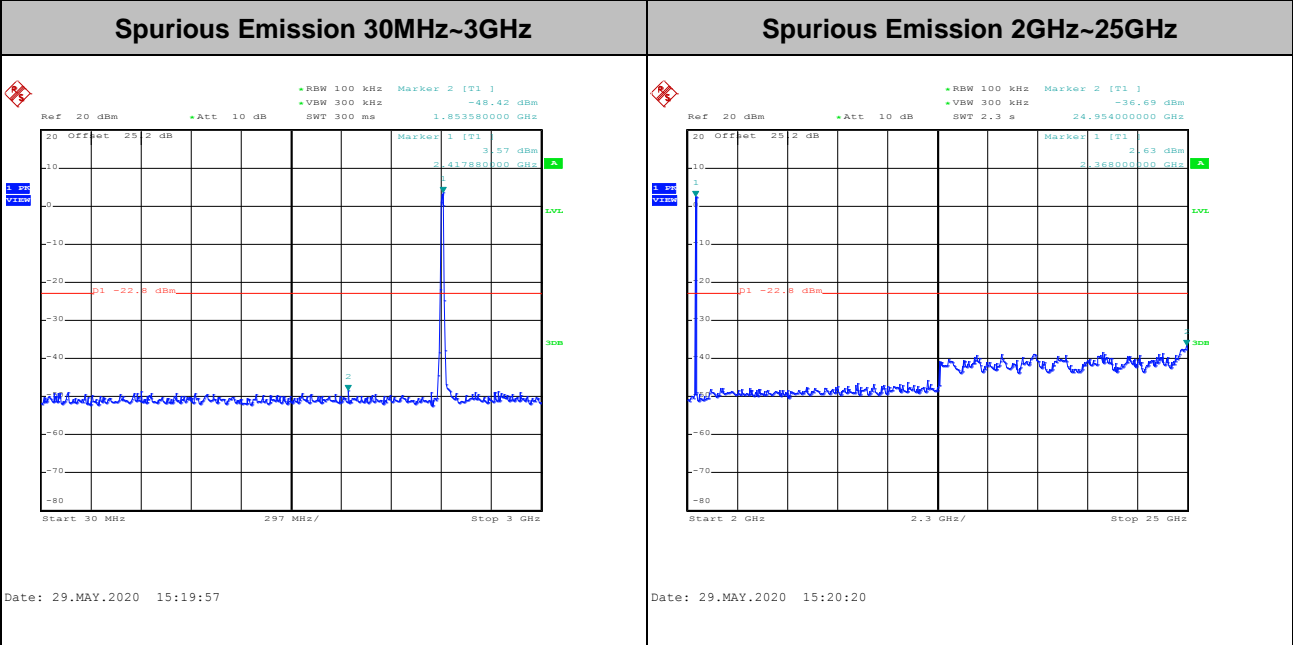
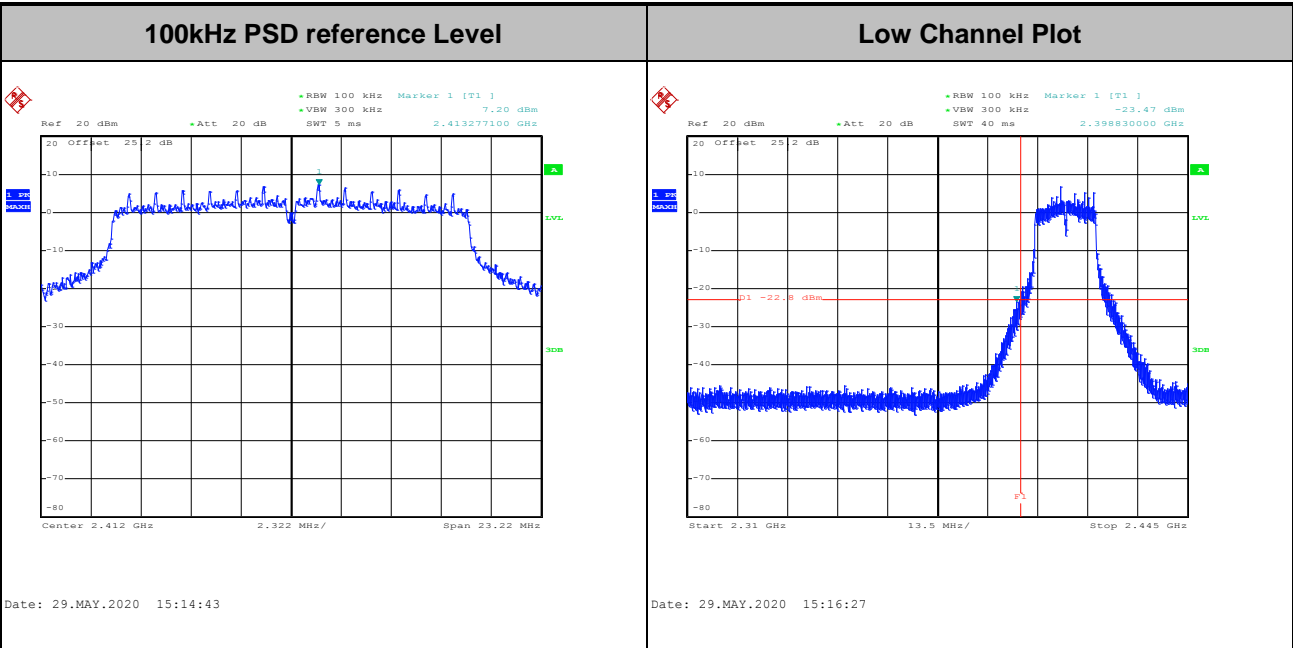



Test Mode :	802.11g	Test Channel :	06
-------------	---------	----------------	----

100kHz PSD reference Level	Mid Channel Plot
-----------------------------------	-------------------------

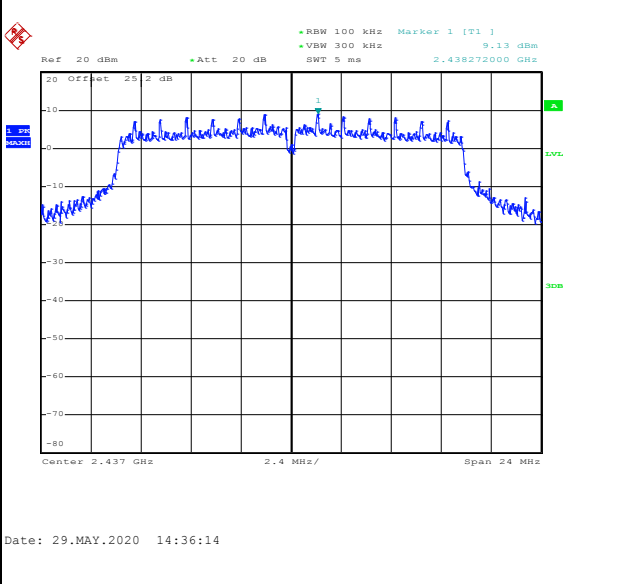

Spurious Emission 30MHz~3GHz	Spurious Emission 2GHz~25GHz
-------------------------------------	-------------------------------------

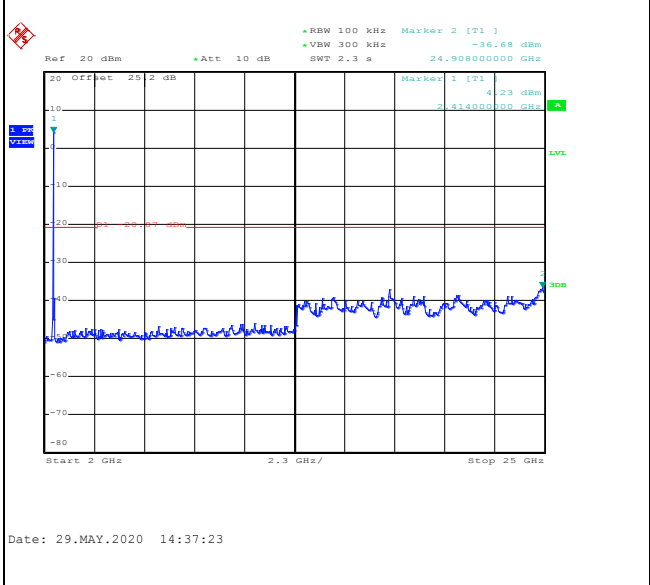
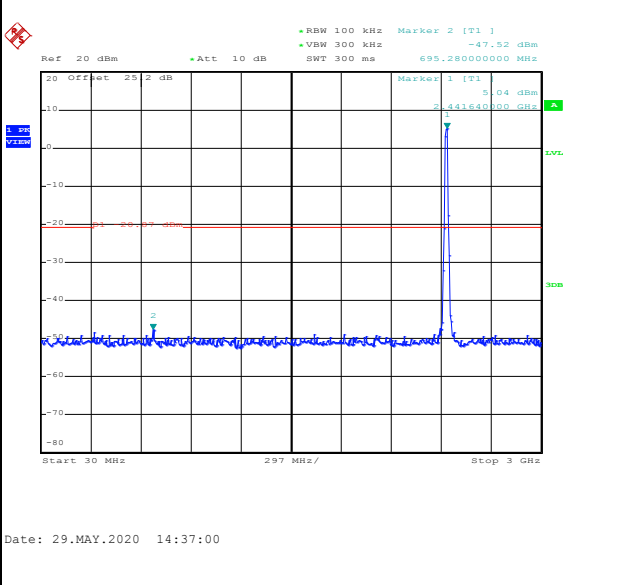



Test Mode :	802.11g	Test Channel :	11
-------------	---------	----------------	----

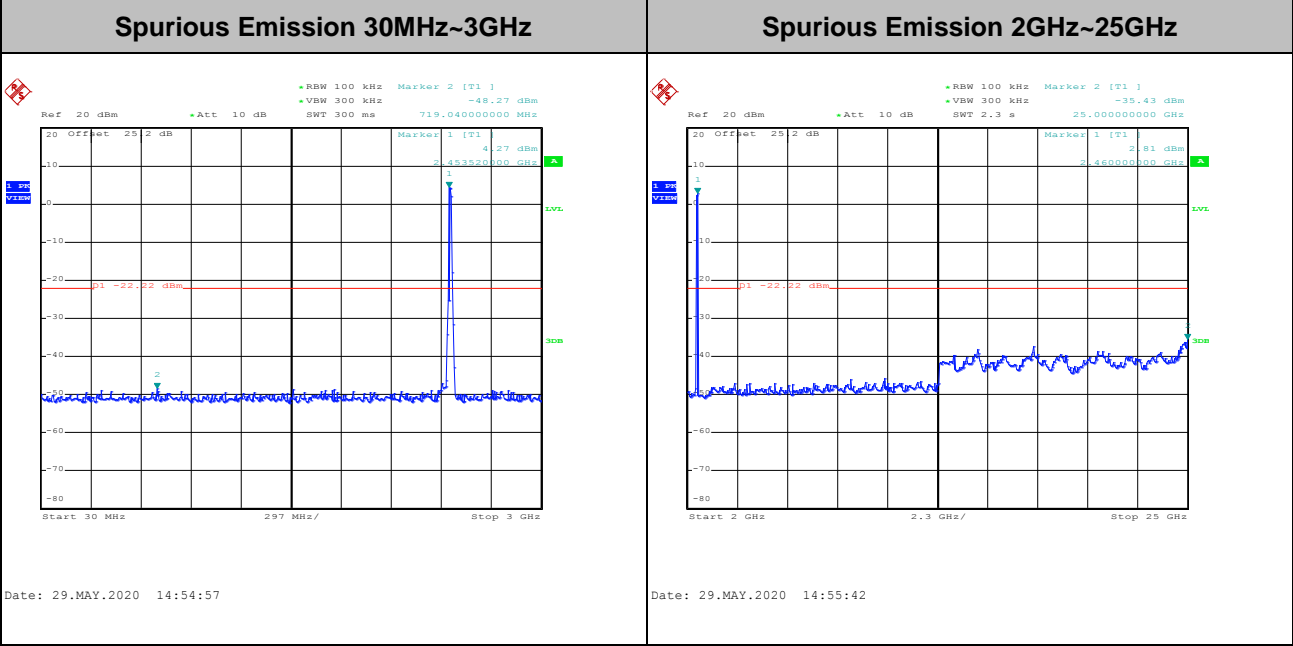
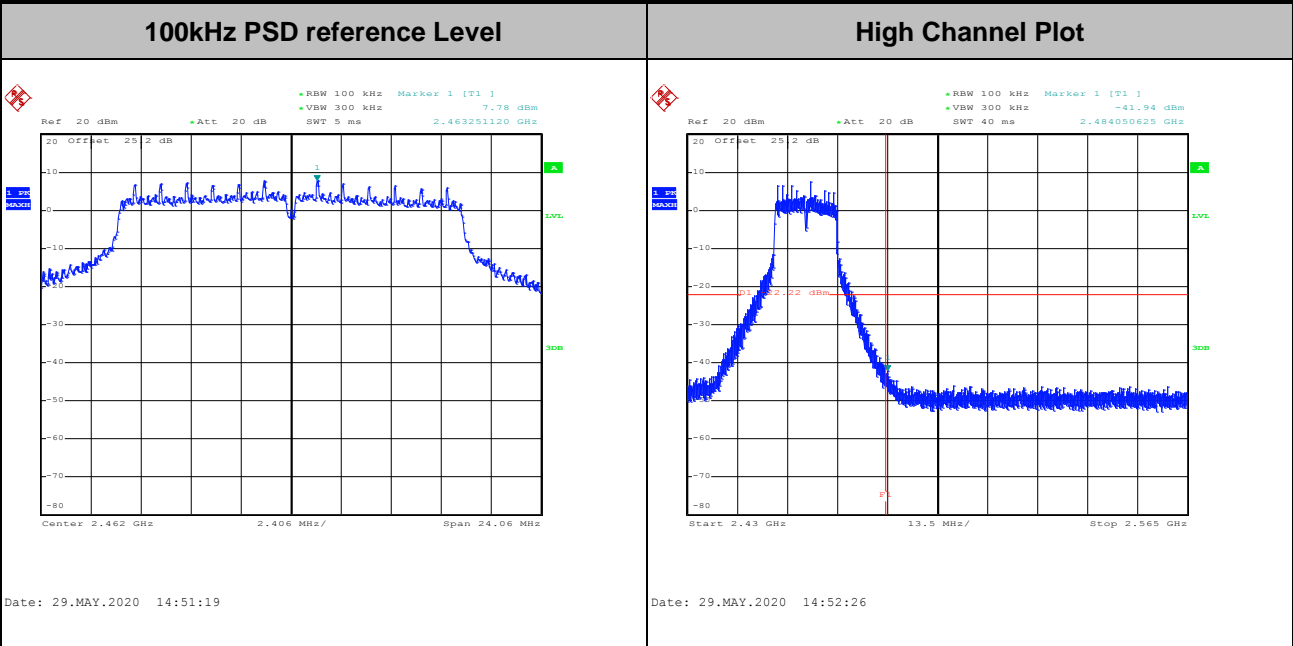



Test Mode :	802.11n HT20	Test Channel :	01
-------------	--------------	----------------	----

100kHz PSD reference Level	Low Channel Plot
-----------------------------------	-------------------------

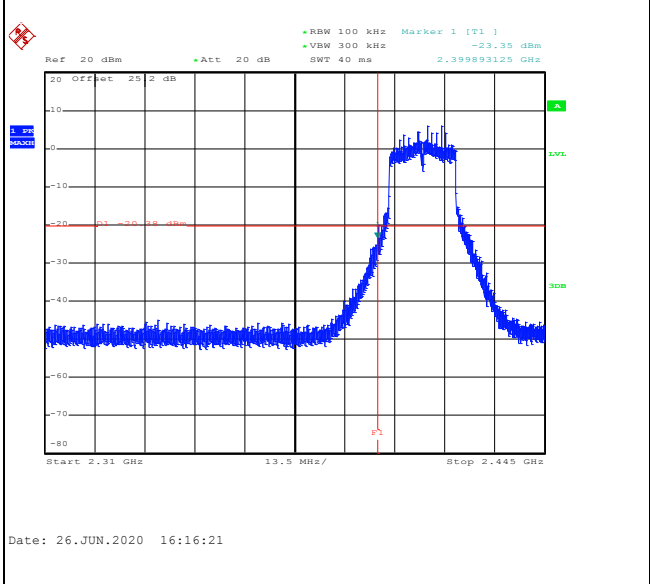
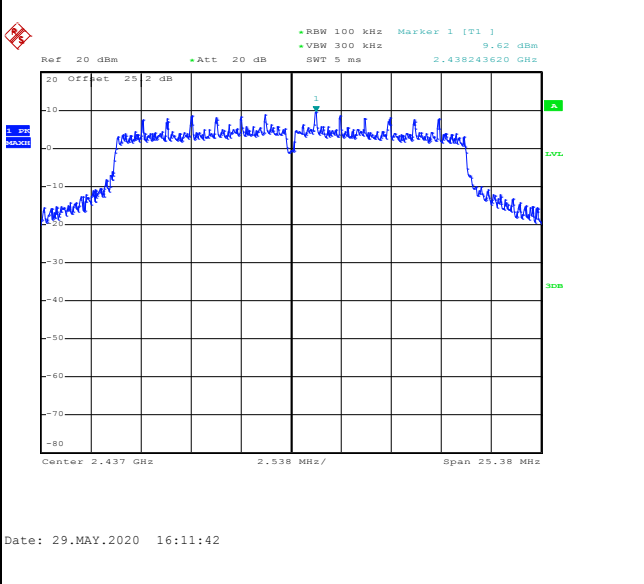

Spurious Emission 30MHz~3GHz	Spurious Emission 2GHz~25GHz
-------------------------------------	-------------------------------------

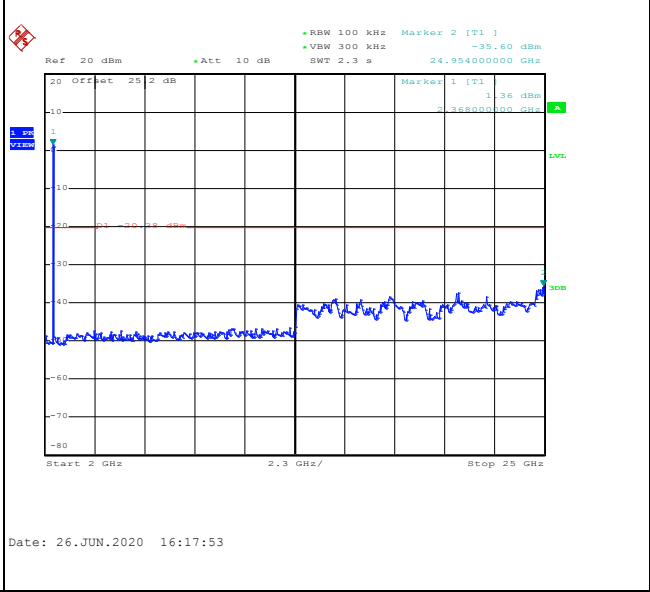
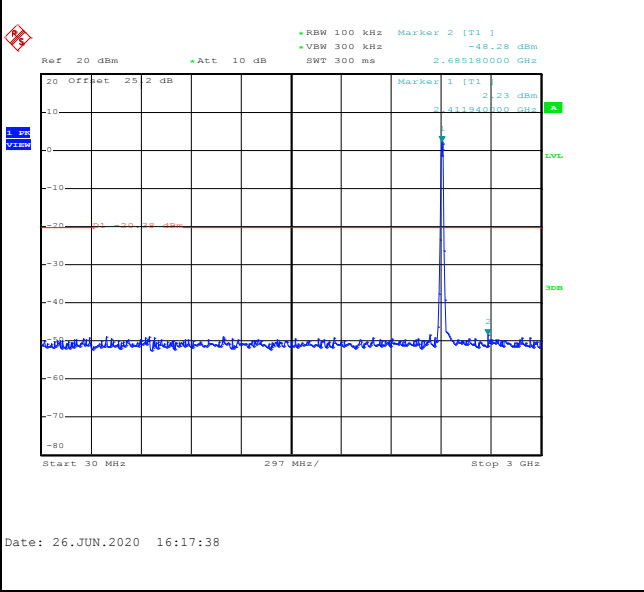



Test Mode :	802.11n HT20	Test Channel :	06
-------------	--------------	----------------	----

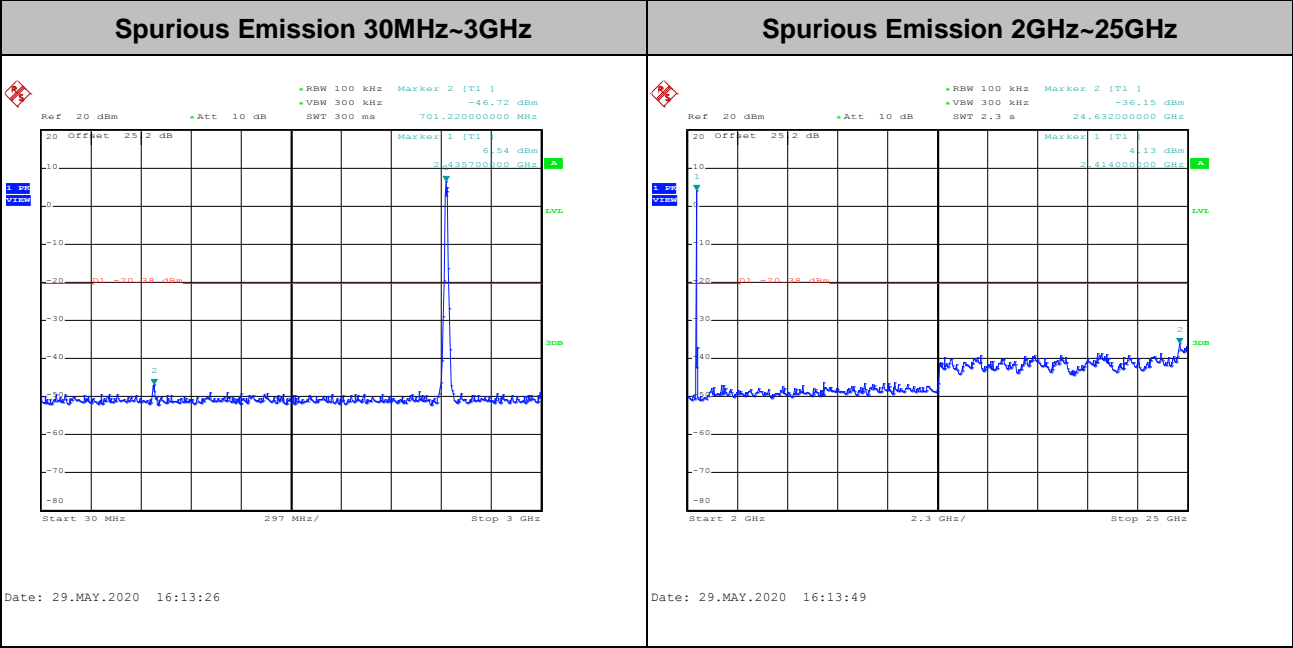
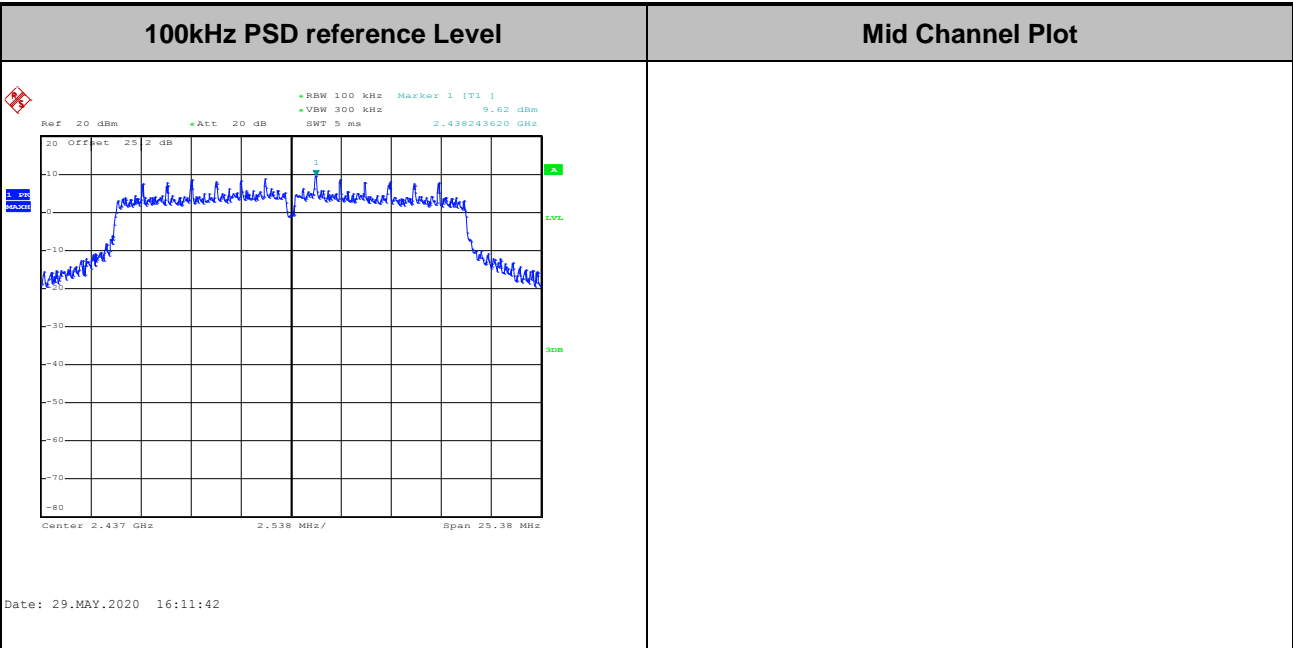



Test Mode :	802.11n HT20	Test Channel :	11
-------------	--------------	----------------	----

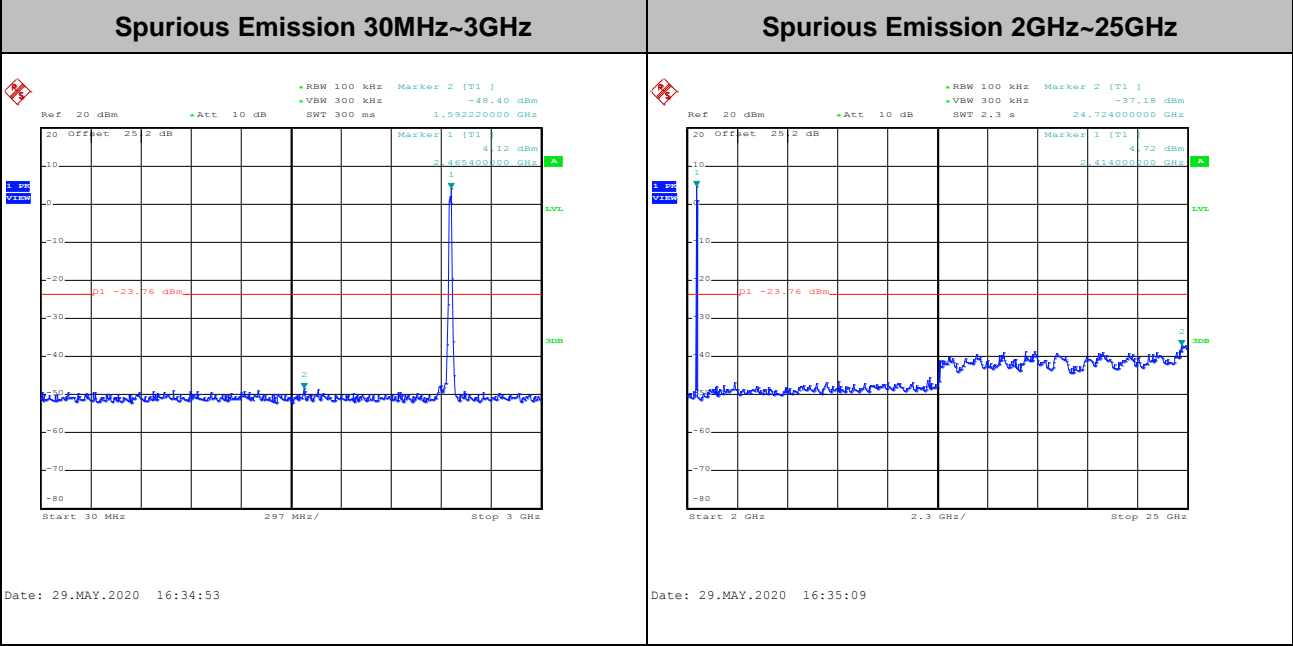
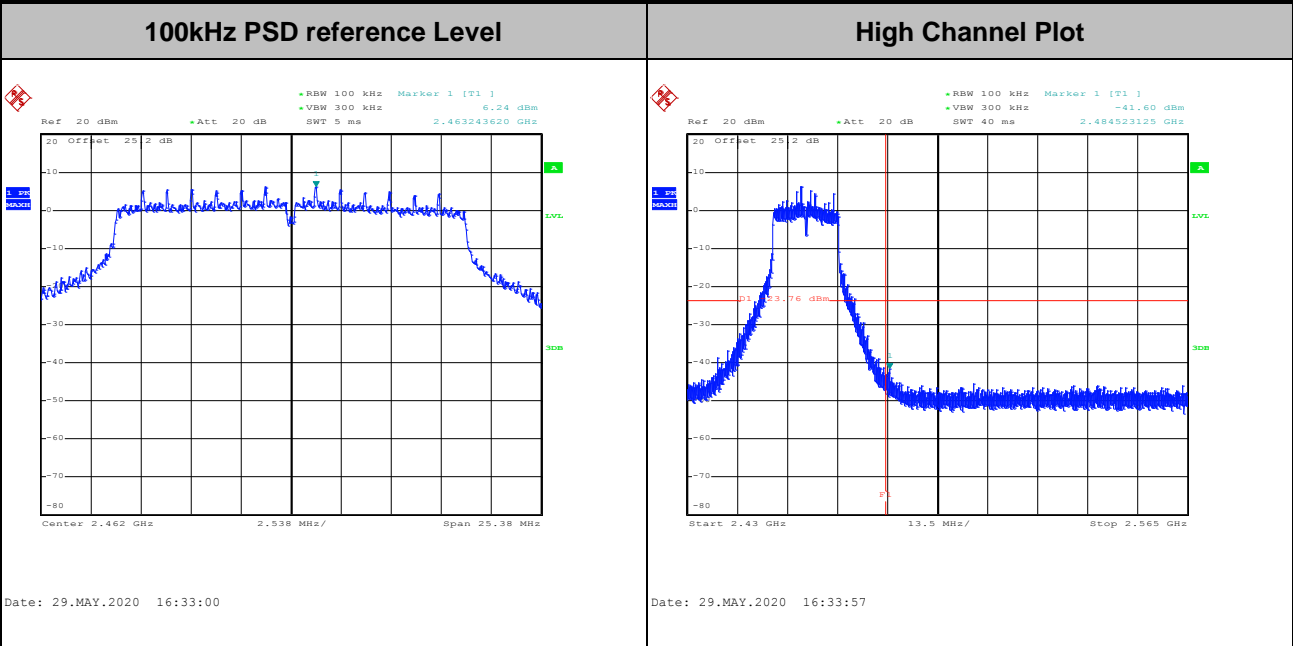



Number of TX = 2, Ant. 3 (Measured)

Test Mode :	802.11b	Test Channel :	01
-------------	---------	----------------	----

100kHz PSD reference Level	Low Channel Plot
-----------------------------------	-------------------------

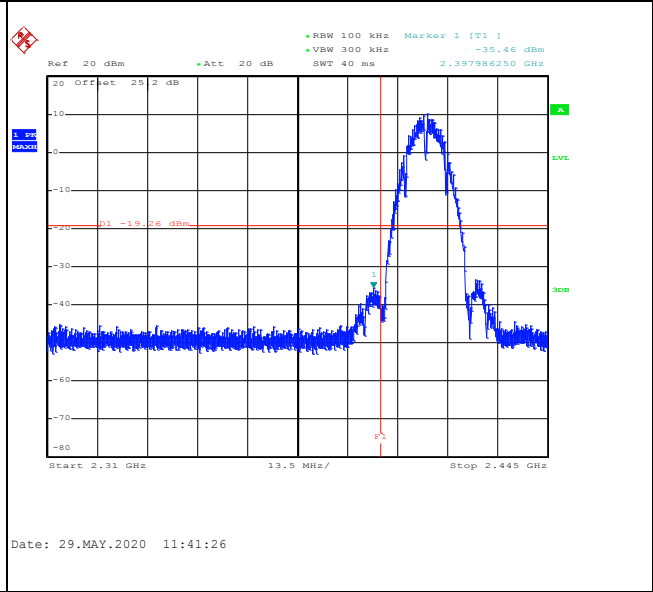
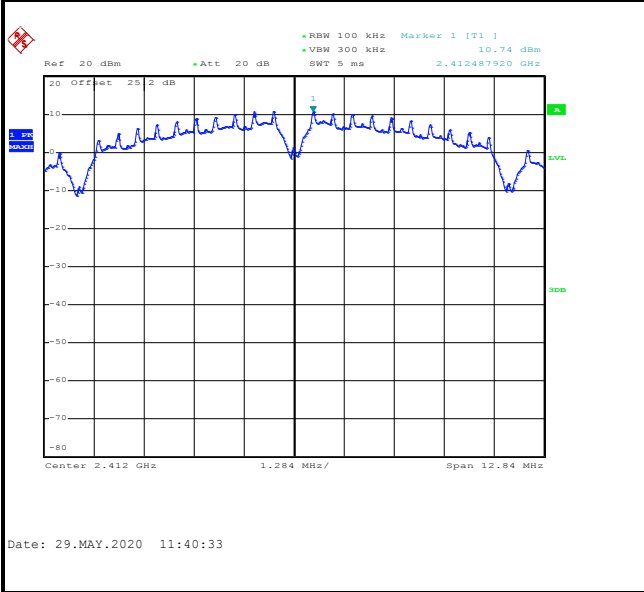

Spurious Emission 30MHz~3GHz	Spurious Emission 2GHz~25GHz
-------------------------------------	-------------------------------------

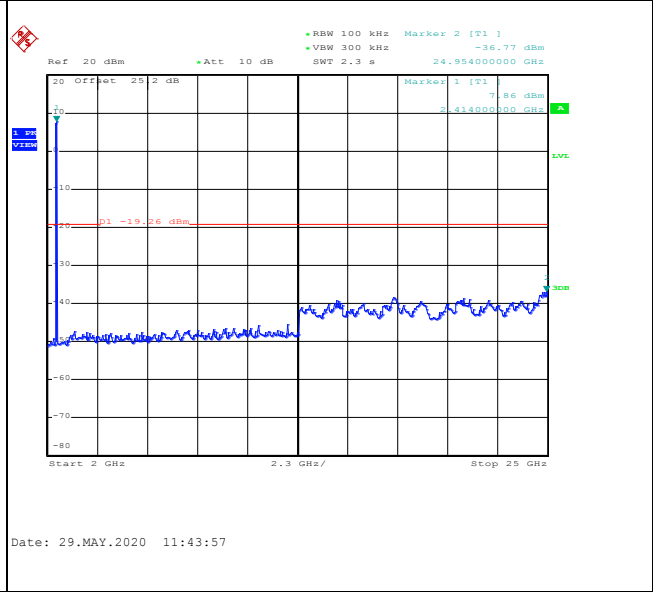
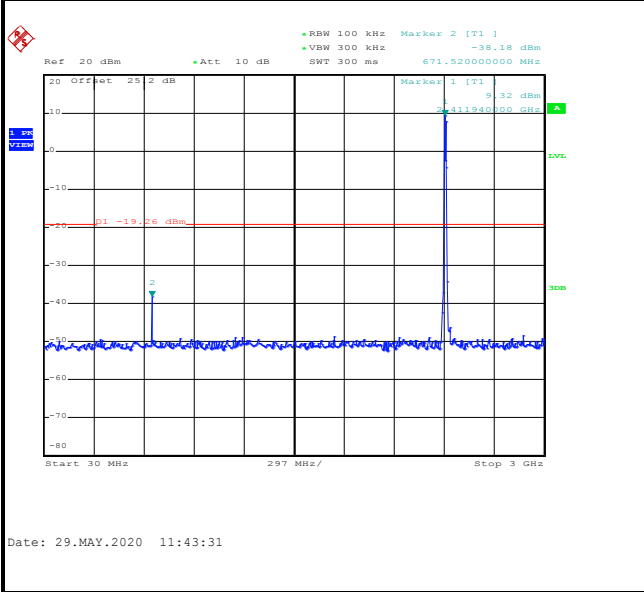



Test Mode :	802.11b	Test Channel :	06
-------------	---------	----------------	----

100kHz PSD reference Level	Mid Channel Plot
-----------------------------------	-------------------------

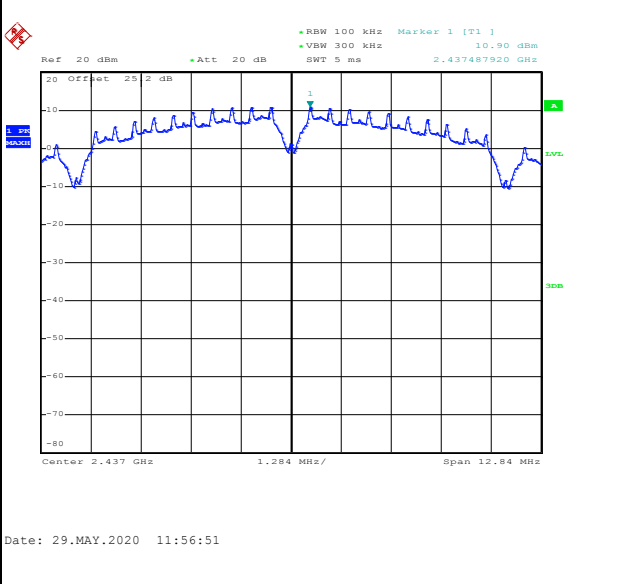

Spurious Emission 30MHz~3GHz	Spurious Emission 2GHz~25GHz
-------------------------------------	-------------------------------------

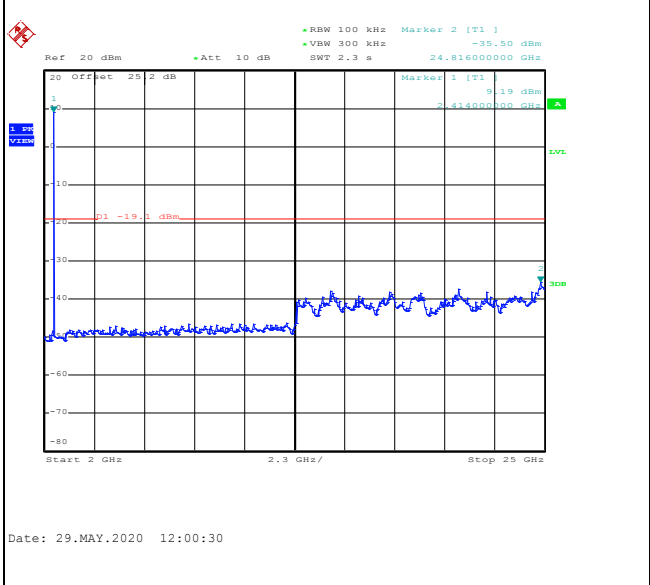
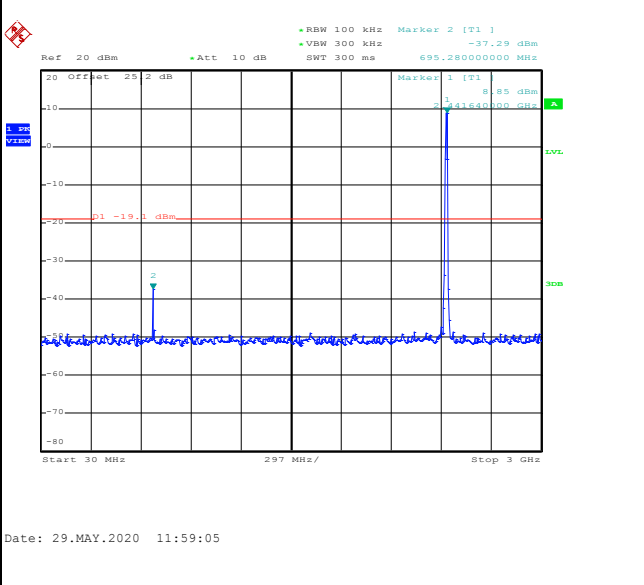



Test Mode :	802.11b	Test Channel :	11
-------------	---------	----------------	----

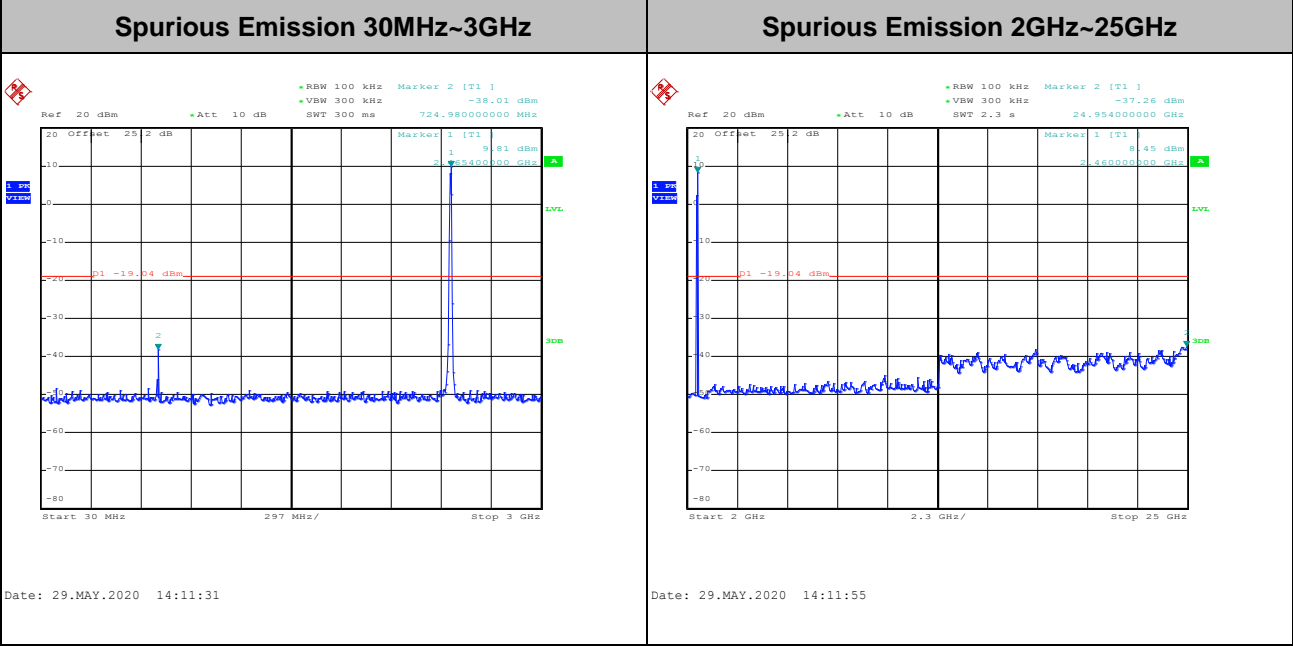
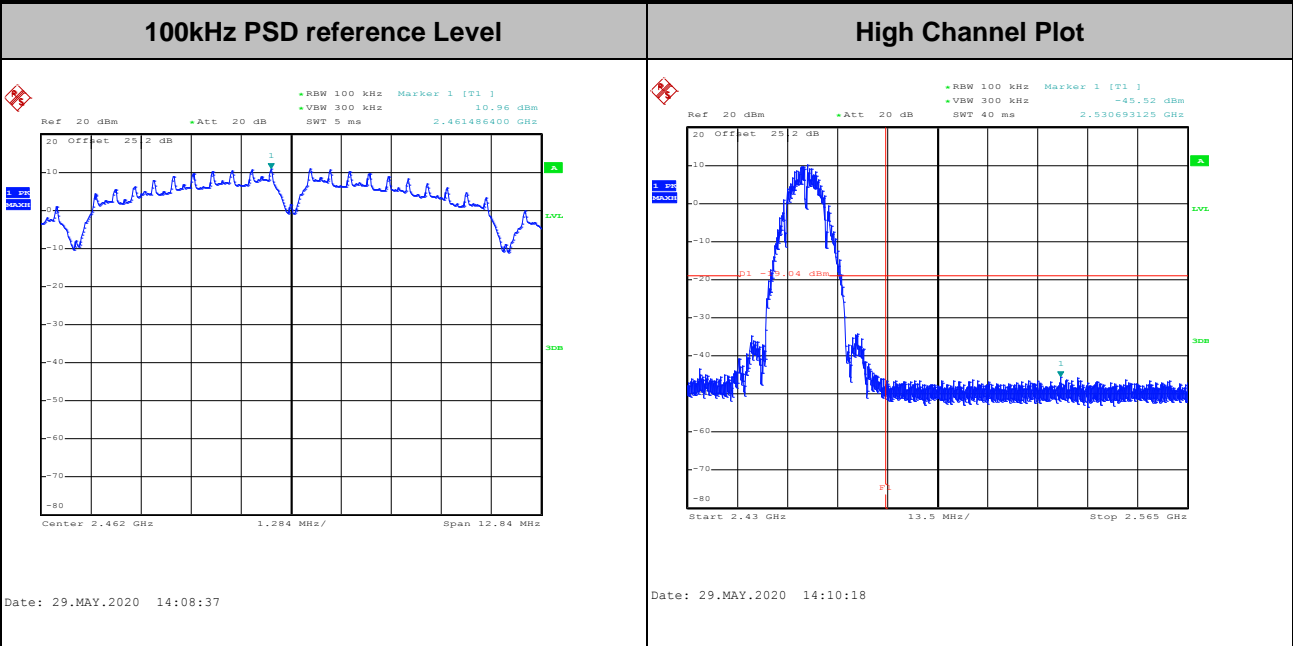



Test Mode :	802.11g	Test Channel :	01
-------------	---------	----------------	----

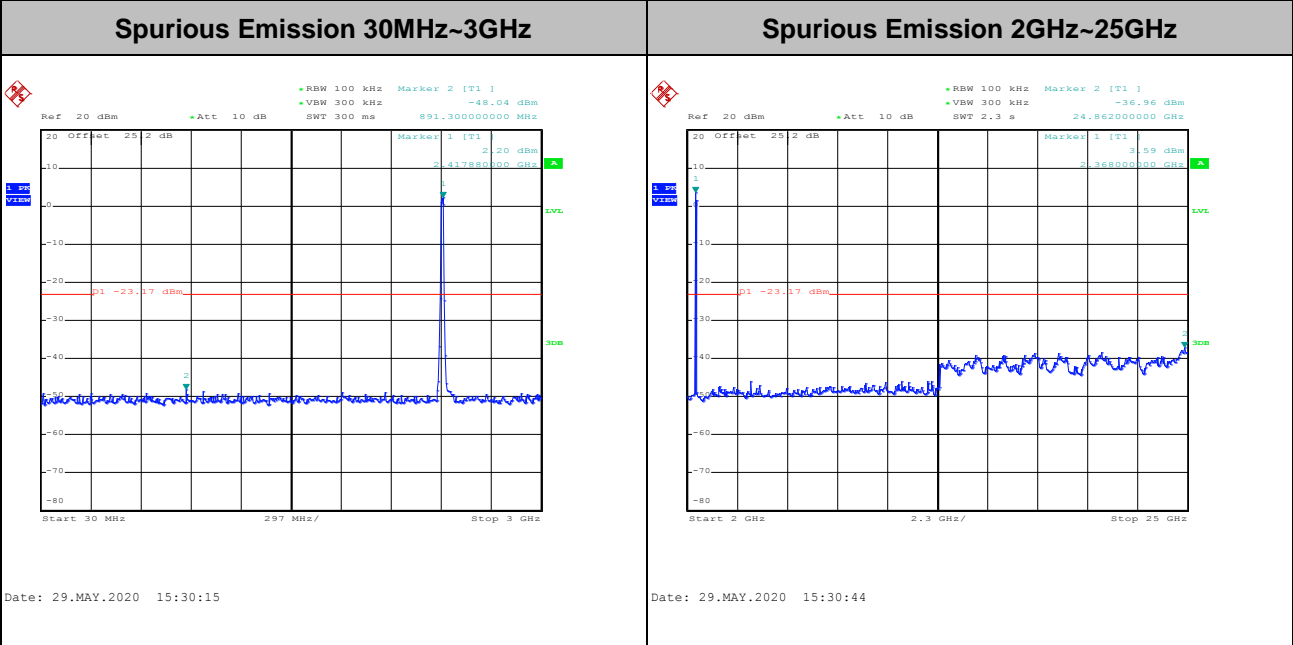
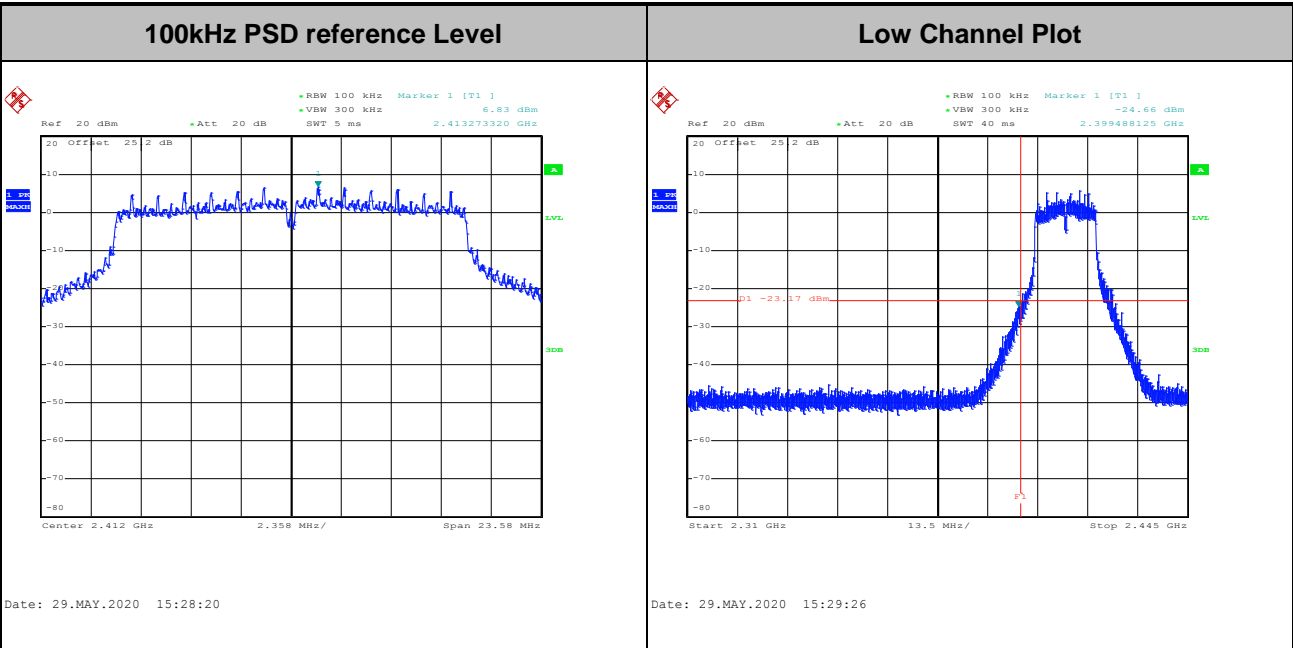



Test Mode :	802.11g	Test Channel :	06
-------------	---------	----------------	----

100kHz PSD reference Level	Mid Channel Plot
-----------------------------------	-------------------------

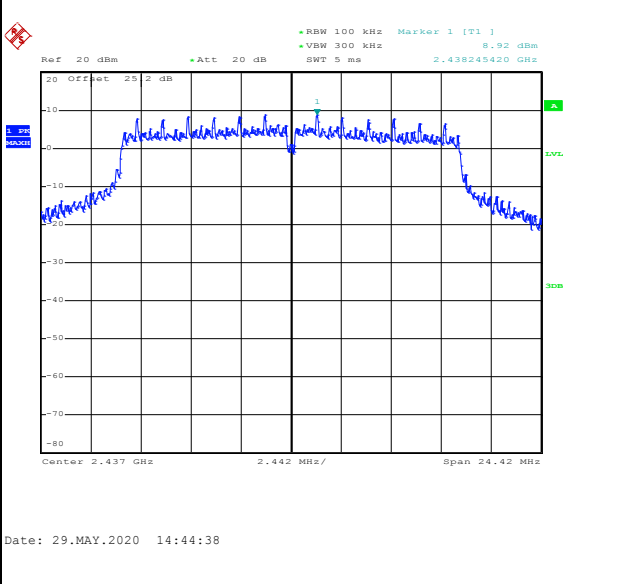

Spurious Emission 30MHz~3GHz	Spurious Emission 2GHz~25GHz
-------------------------------------	-------------------------------------

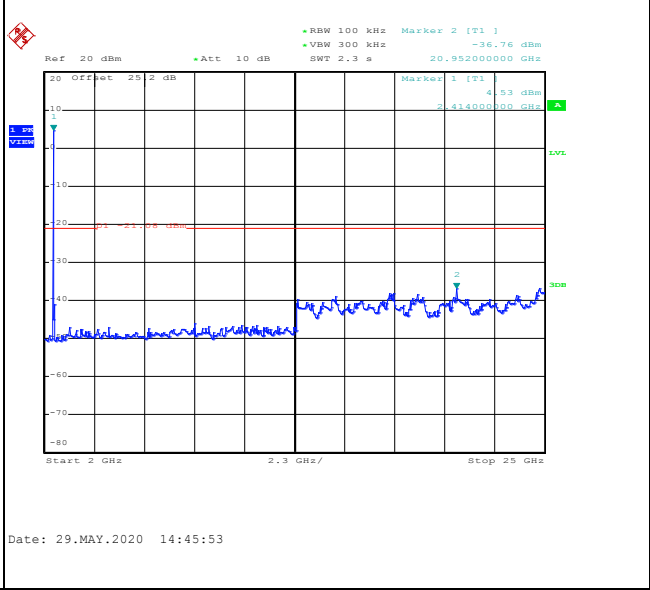
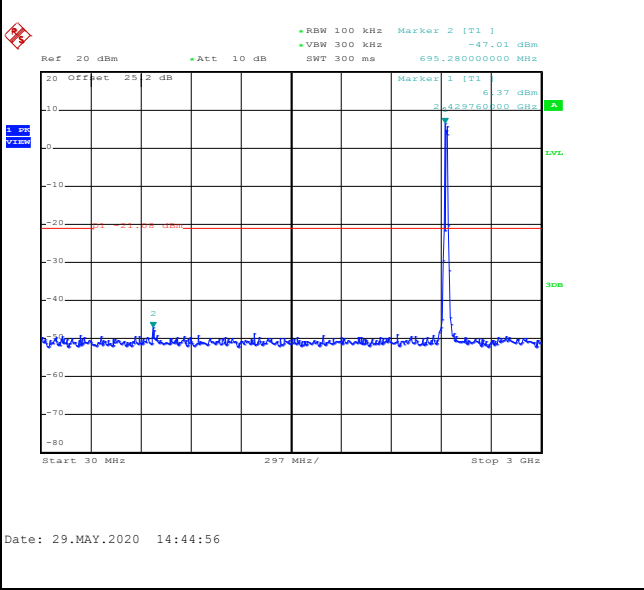



Test Mode :	802.11g	Test Channel :	11
-------------	---------	----------------	----

100kHz PSD reference Level	High Channel Plot
-----------------------------------	--------------------------

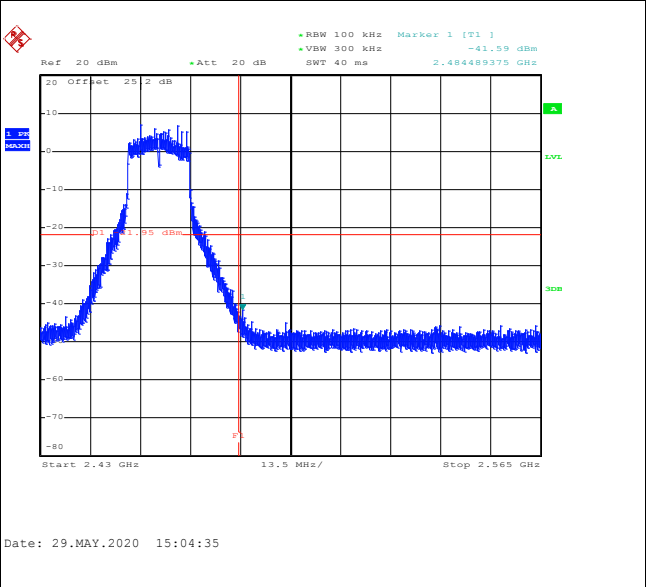
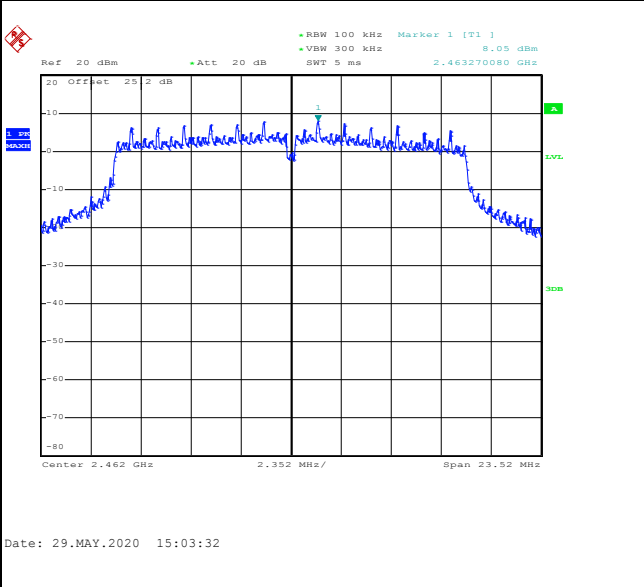

Spurious Emission 30MHz~3GHz	Spurious Emission 2GHz~25GHz
-------------------------------------	-------------------------------------

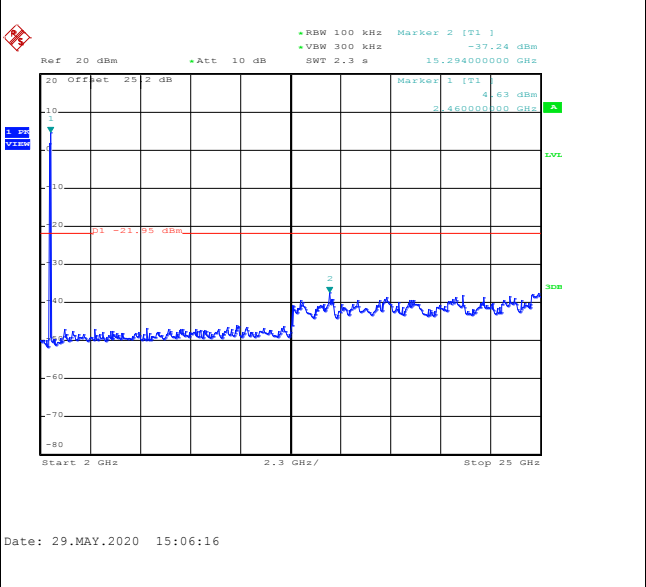
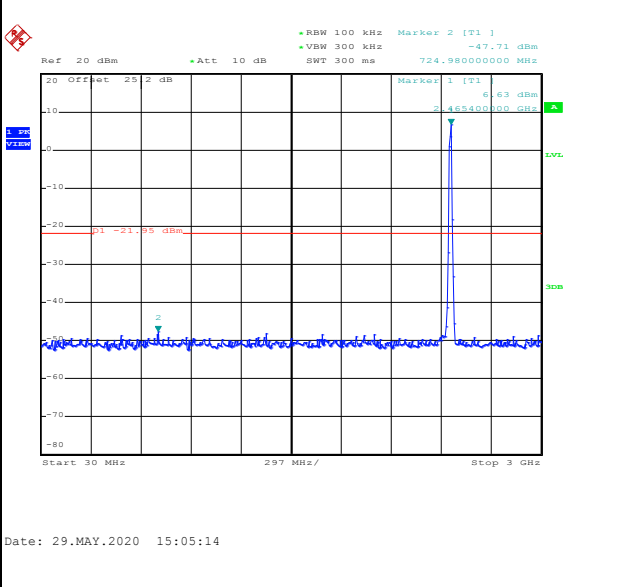



Test Mode :	802.11n HT20	Test Channel :	01
-------------	--------------	----------------	----

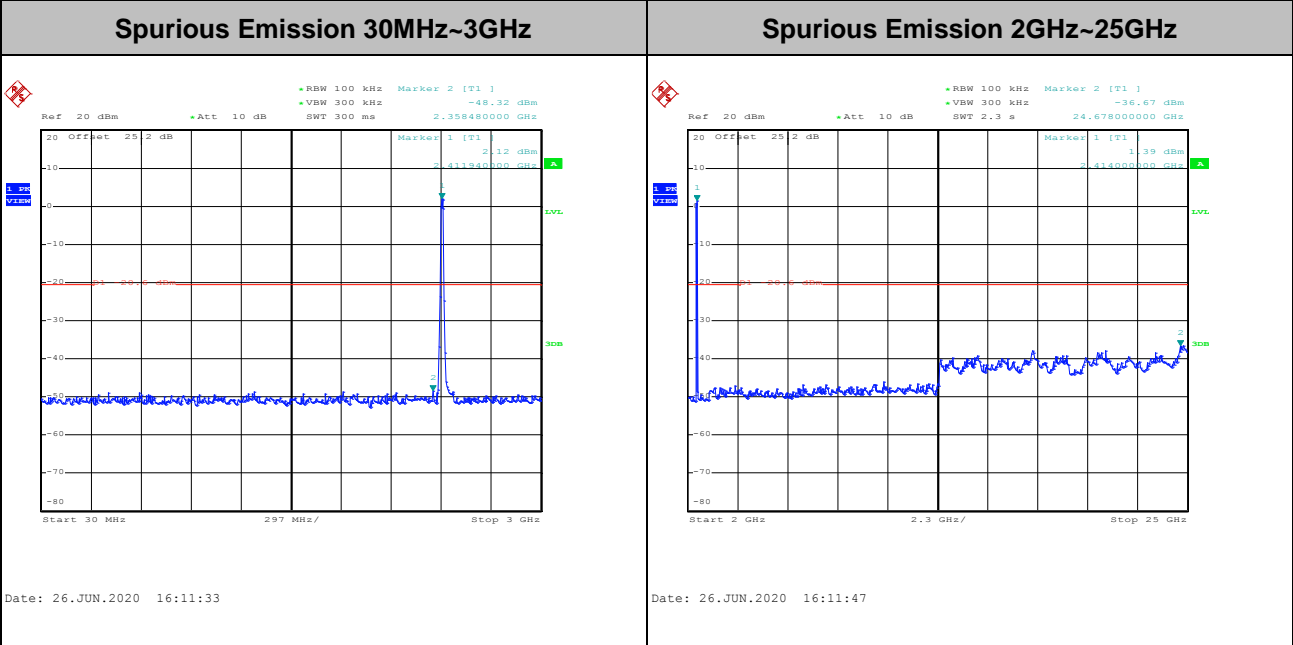
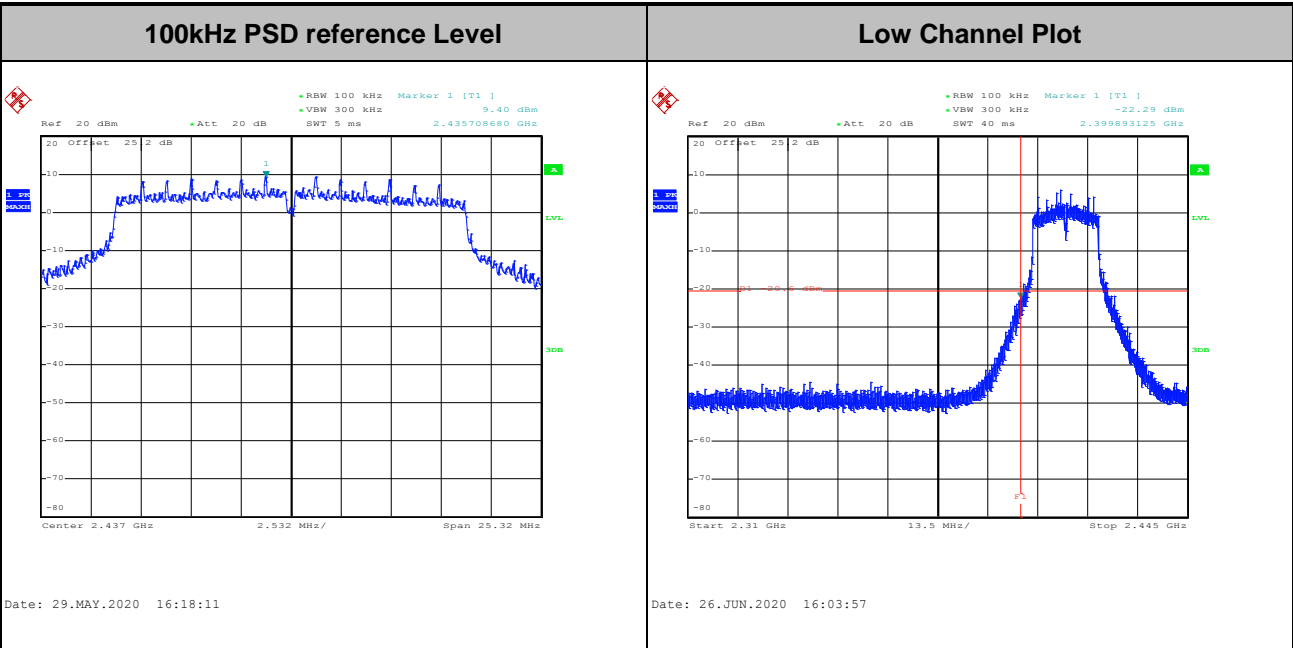



Test Mode :	802.11n HT20	Test Channel :	06
-------------	--------------	----------------	----

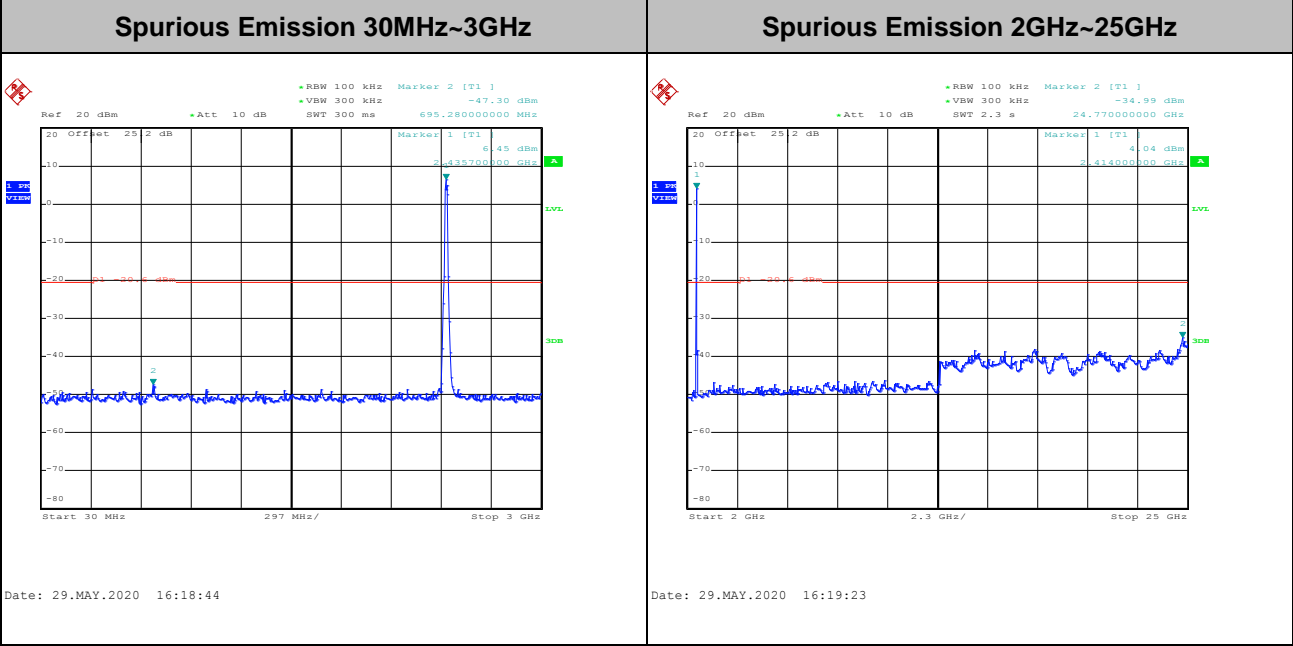
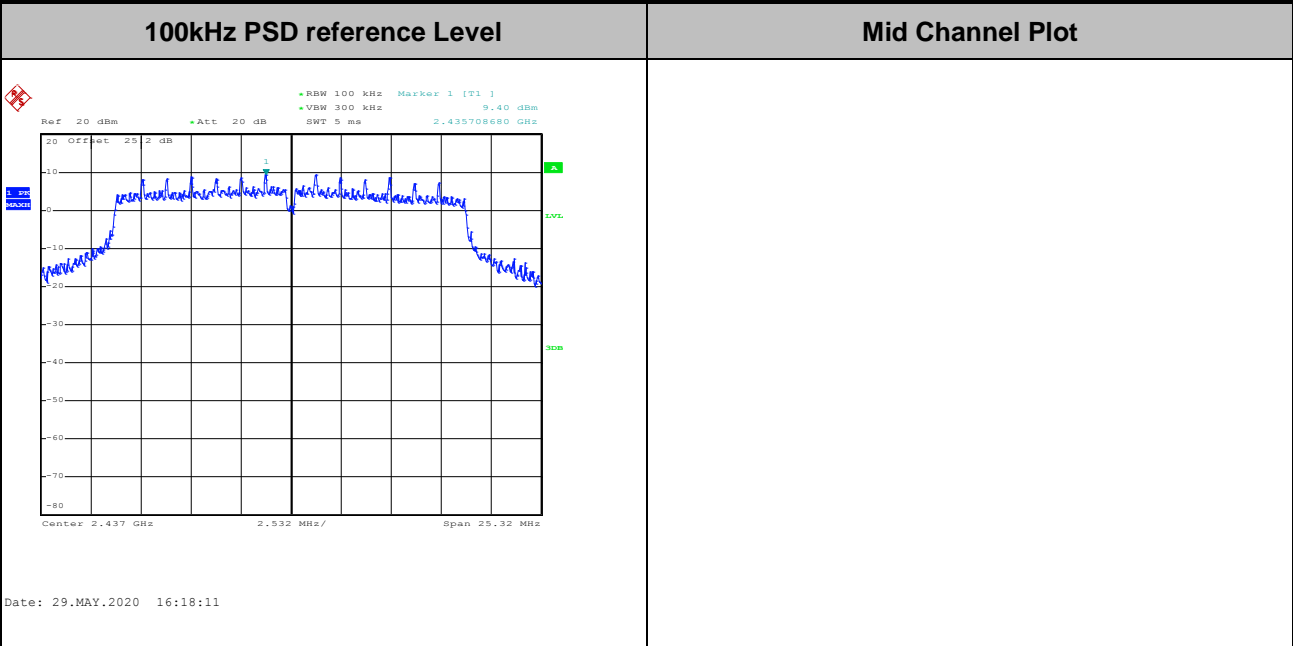



Test Mode :	802.11n HT20	Test Channel :	11
--------------------	--------------	-----------------------	----

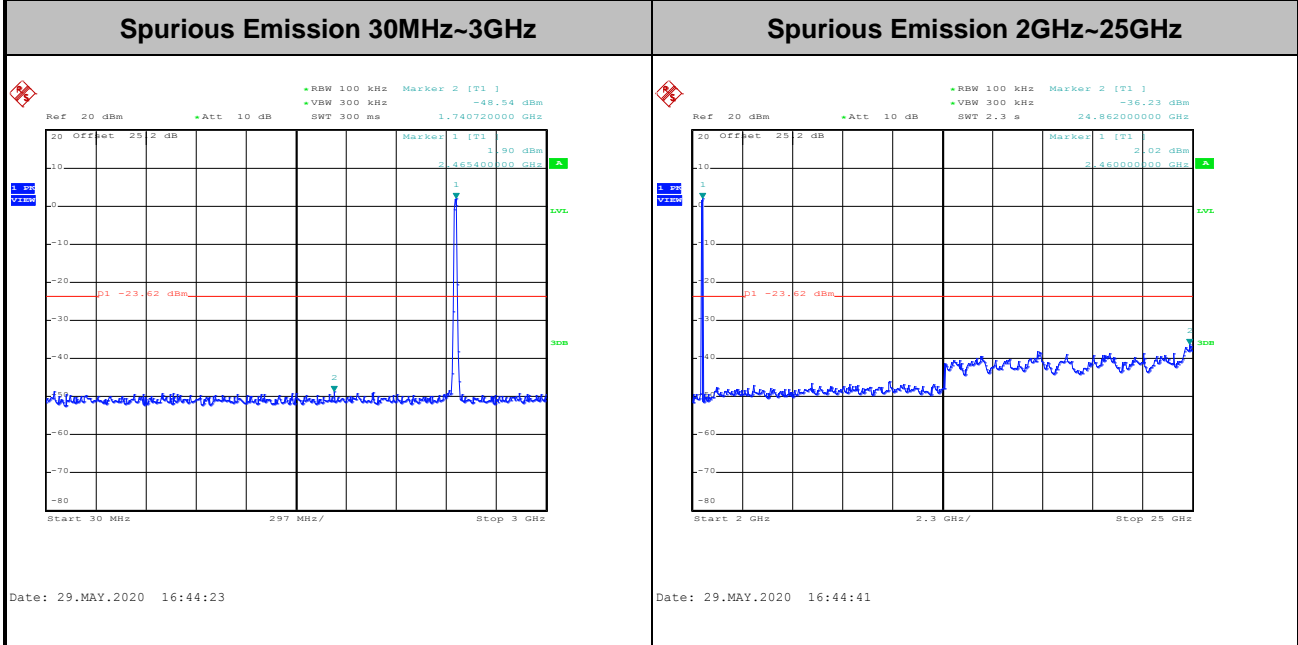
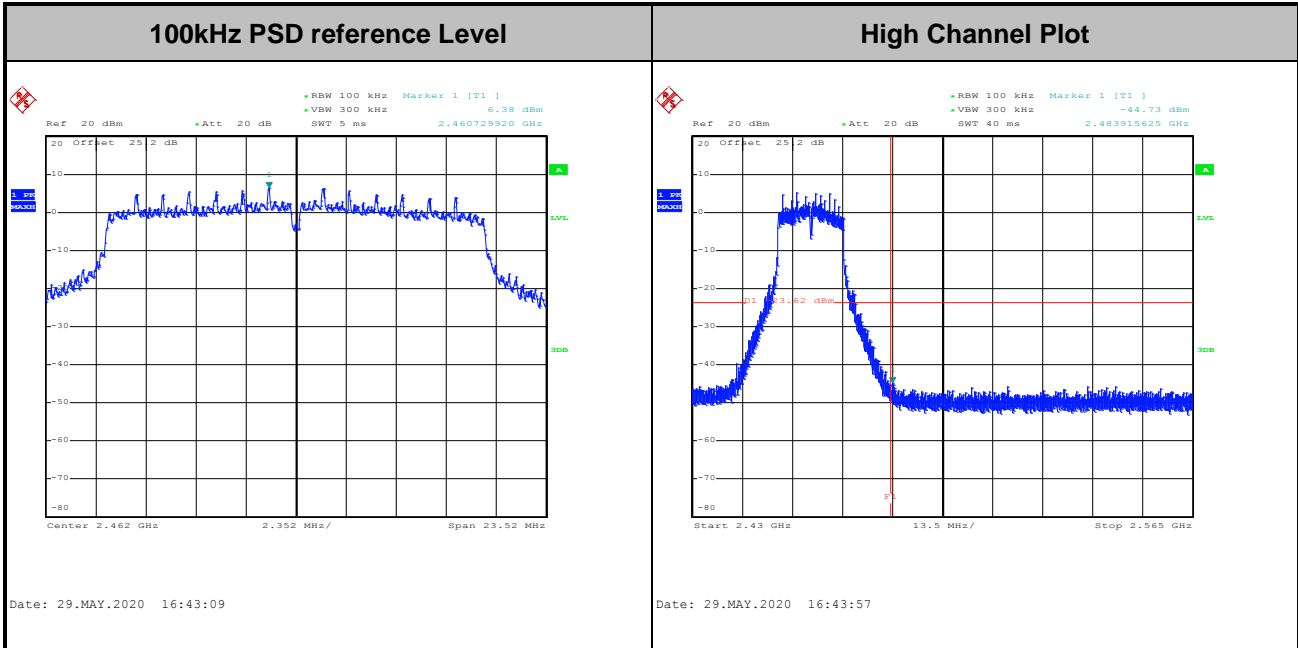



3.5 Radiated Band Edges and Spurious Emission Measurement

3.5.1 Limit of Radiated band edge and Spurious Emission Measurement

In any 100 kHz bandwidth outside the intentional radiator frequency band, all harmonics/spurious must be at least 20 dB below the highest emission level within the authorized band. If the output power of this device was measured by spectrum analyzer, the attenuation under this paragraph shall be 30 dB instead of 20 dB. In addition, radiated emissions which fall in the restricted bands must also comply with the limits as below.

Frequency (MHz)	Field Strength (microvolts/meter)	Measurement Distance (meters)
0.009 – 0.490	2400/F(kHz)	300
0.490 – 1.705	24000/F(kHz)	30
1.705 – 30.0	30	30
30 – 88	100	3
88 – 216	150	3
216 - 960	200	3
Above 960	500	3

3.5.2 Measuring Instruments

See list of measuring equipment of this test report.

**3.5.3 Test Procedures**

1. The testing follows the ANSI C63.10 Section 11.12.1 Radiated emission measurements.
2. The EUT was arranged to its worst case and then tune the antenna tower (from 1 m to 4 m) and turntable (from 0 degree to 360 degrees) to find the maximum reading. A pre-amp and a high pass filter are used for the test in order to get better signal level.
3. The EUT was placed on a turntable with 0.8 meter for frequency below 1GHz and 1.5 meter for frequency above 1GHz respectively above ground.
4. The EUT was set 3 meters from the interference receiving antenna, which was mounted on the top of a variable height antenna tower.
5. Corrected Reading: Antenna Factor + Cable Loss + Read Level - Preamp Factor = Level
6. For testing below 1GHz, if the emission level of the EUT in peak mode was 3 dB lower than the limit specified, then peak values of EUT will be reported, otherwise, the emissions will be repeated one by one using the CISPR quasi-peak method and reported.
7. For testing above 1GHz, the emission level of the EUT in peak mode was 20dB lower than average limit (that means the emission level in average mode also complies with the limit in average mode), then peak values of EUT will be reported, otherwise, the emissions will be measured in average mode again and reported.
8. Use the following spectrum analyzer settings:
 - (1) Span shall wide enough to fully capture the emission being measured;
 - (2) Set RBW=100 kHz for $f < 1$ GHz; $VBW \geq RBW$; Sweep = auto; Detector function = peak; Trace = max hold;
 - (3) Set RBW = 1 MHz, VBW= 3MHz for $f \geq 1$ GHz for peak measurement.
For average measurement:
 - $VBW = 10$ Hz, when duty cycle is no less than 98 percent.
 - $VBW \geq 1/T$, when duty cycle is less than 98 percent where T is the minimum transmission duration over which the transmitter is on and is transmitting at its maximum power control level for the tested mode of operation.

3.5.4 Test Setup

For radiated emissions below 30MHz

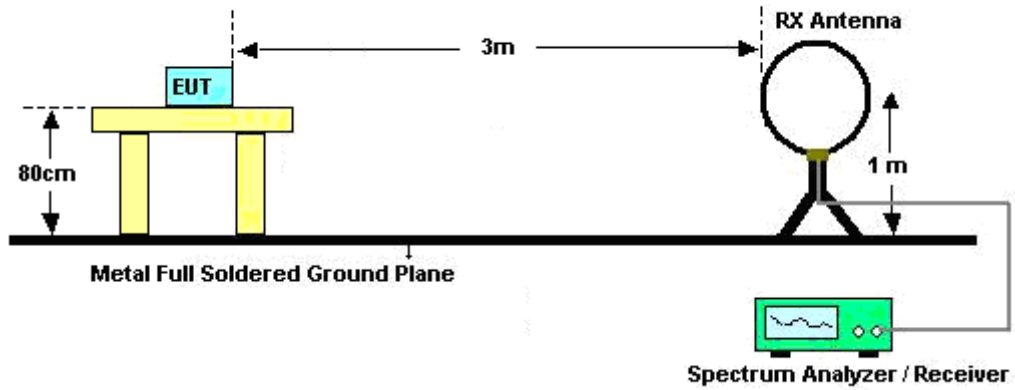

For radiated emissions from 30MHz to 1GHz

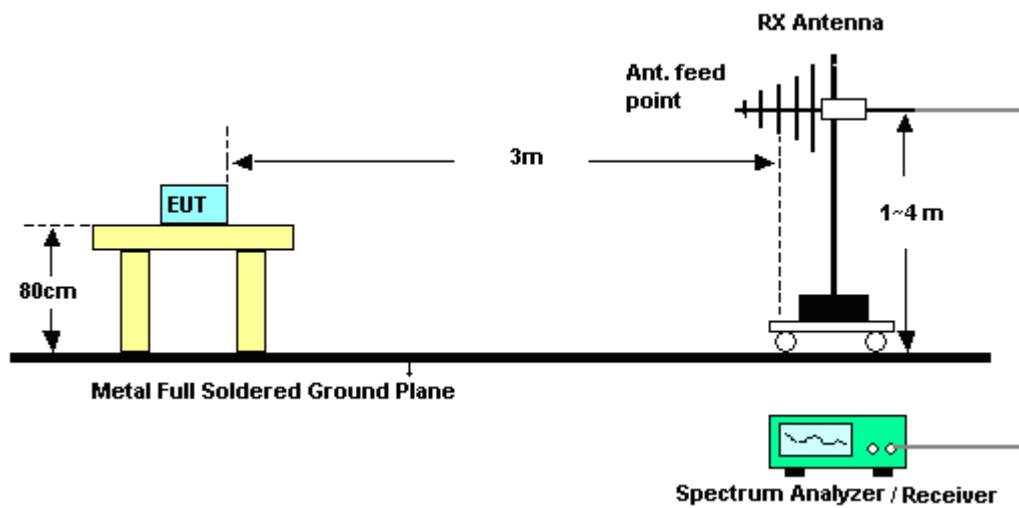

For radiated emissions above 1GHz

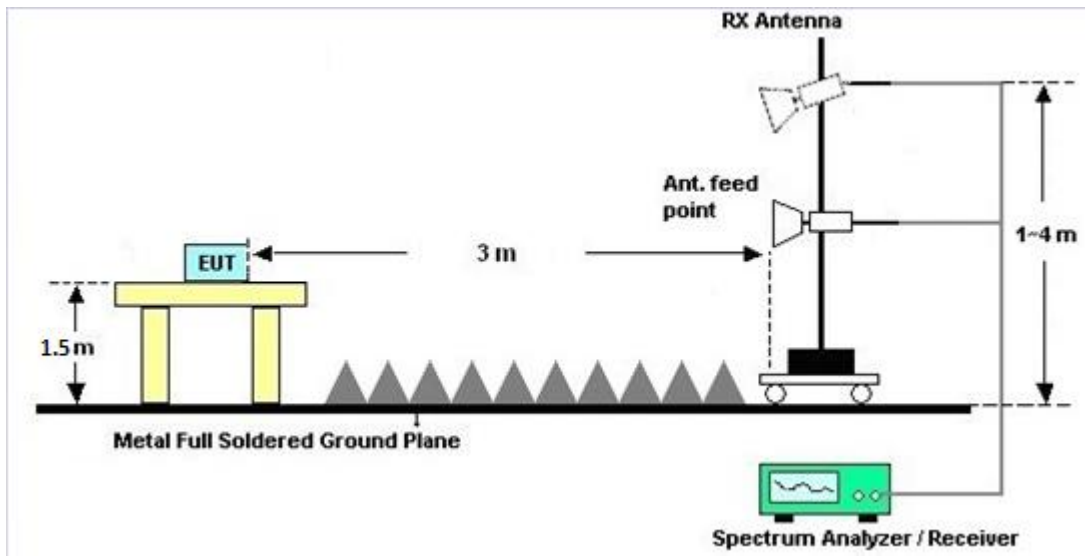

For radiated emissions above 18GHz

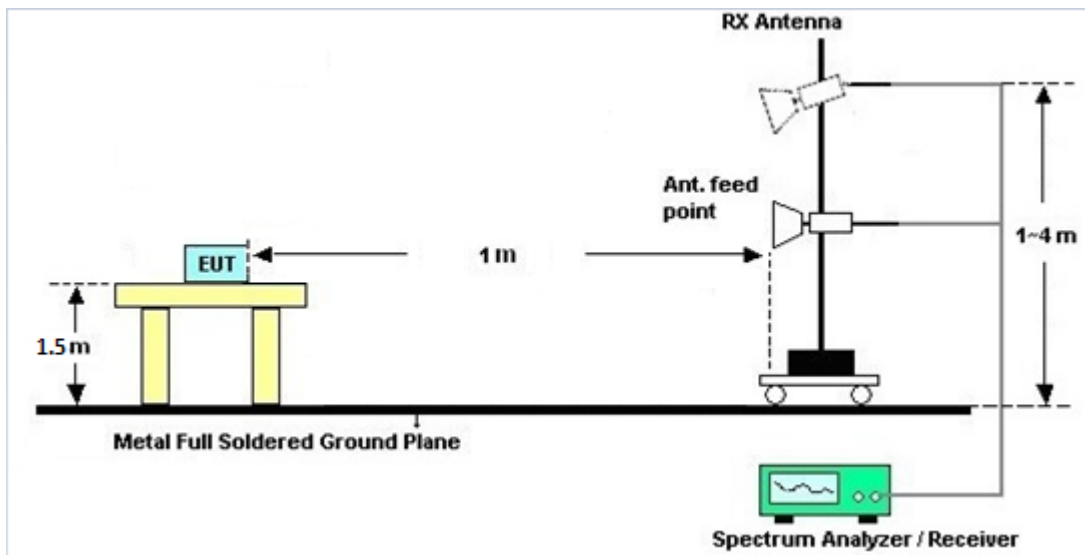



3.5.5 Test Results of Radiated Spurious Emissions (9kHz ~ 30MHz)

The low frequency, which started from 9 kHz to 30MHz, was pre-scanned and the result which was 20dB lower than the limit line was not reported.

There is a comparison data of both open-field test site and alternative test site - semi-Anechoic chamber according to 414788 D01 Radiated Test Site v01r01, and the result came out very similar.

3.5.6 Test Result of Radiated Spurious at Band Edges

Please refer to Appendix C and D.

3.5.7 Duty Cycle

Please refer to Appendix E.

3.5.8 Test Result of Radiated Spurious Emission (30MHz ~ 10th Harmonic)

Please refer to Appendix C and D.



3.6 AC Conducted Emission Measurement

3.6.1 Limit of AC Conducted Emission

For equipment that is designed to be connected to the public utility (AC) power line, the radio frequency voltage that is conducted back onto the AC power line on any frequency or frequencies within the band 150 kHz to 30 MHz shall not exceed the limits in the following table.

Frequency of Emission (MHz)	Conducted Limit (dB μ V)	
	Quasi-Peak	Average
0.15-0.5	66 to 56*	56 to 46*
0.5-5	56	46
5-30	60	50

*Decreases with the logarithm of the frequency.

3.6.2 Measuring Instruments

See list of measuring equipment of this test report.

3.6.3 Test Procedures

1. The EUT was placed 0.4 meter from the conducting wall of the shielding room, and it was kept at least 80 centimeters from any other grounded conducting surface.
2. Connect EUT to the power mains through a line impedance stabilization network (LISN).
3. All the support units are connecting to the other LISN.
4. The LISN provides 50 ohm coupling impedance for the measuring instrument.
5. The FCC states that a 50 ohm, 50 microhenry LISN should be used.
6. Both sides of AC line were checked for maximum conducted interference.
7. The frequency range from 150 kHz to 30 MHz was searched.
8. Set the test-receiver system to Peak Detect Function and specified bandwidth (IF bandwidth = 9kHz) with Maximum Hold Mode.

3.6.4 Test Setup

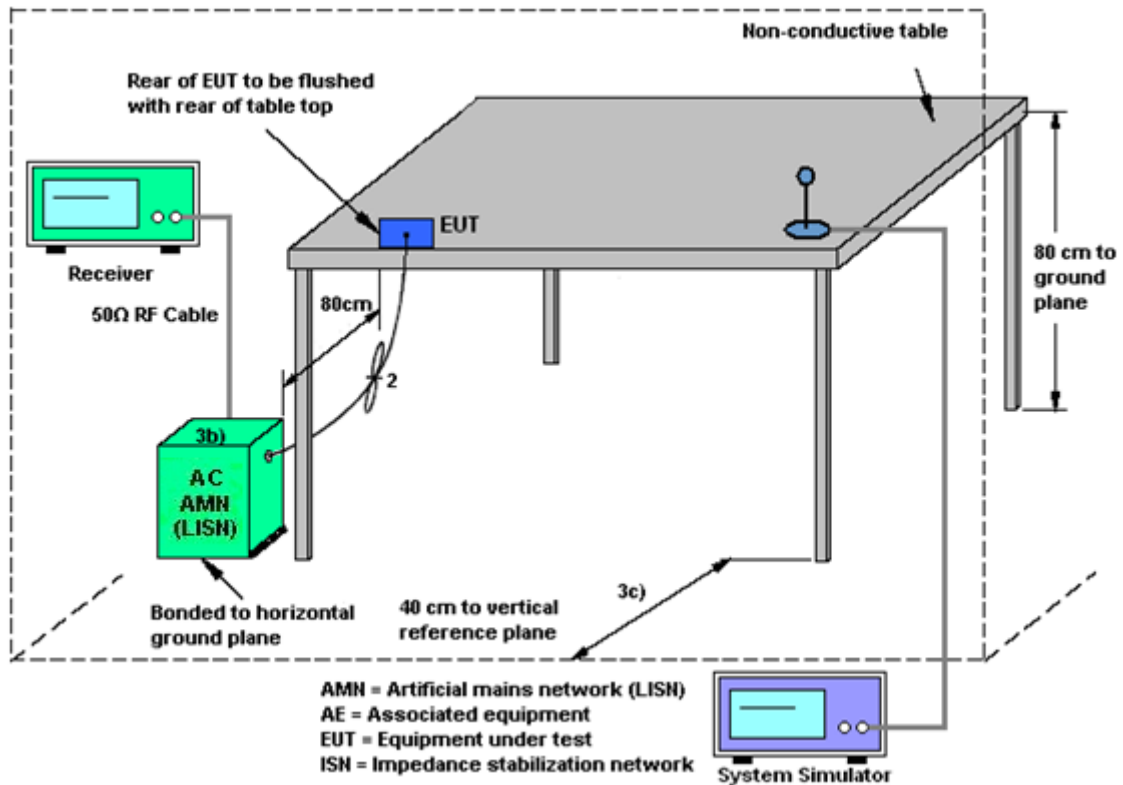

3.6.5 Test Result of AC Conducted Emission

Please refer to Appendix B.



3.7 Antenna Requirements

3.7.1 Standard Applicable

If directional gain of transmitting Antennas is greater than 6dBi, the power shall be reduced by the same level in dB comparing to gain minus 6dBi. The use of a permanently attached Antenna or of an Antenna that uses a unique coupling to the intentional radiator shall be considered sufficient to comply with the rule.

3.7.2 Antenna Anti-Replacement Construction

An embedded-in antenna design is used.

3.7.3 Antenna Gain

<CDD Modes >

FCC KDB 662911 D01 Multiple Transmitter Output v02r01

For CDD transmissions, directional gain is calculated as

Directional gain = G_{ANT} + Array Gain, where Array Gain is as follows.

For power spectral density (PSD) measurements on all devices,

Array Gain = $10 \log(N_{ANT}/N_{SS}=1)$ dB.

For power measurements on IEEE 802.11 devices,

Array Gain = 0 dB (i.e., no array gain) for $N_{ANT} \leq 4$.

Directional gain may be calculated by using the formulas applicable to equal gain antennas with G_{ANT} set equal to the gain of the antenna having the highest gain;

The EUT supports CDD mode.

For power, the directional gain G_{ANT} is set equal to the antenna having the highest gain, i.e., F)2)f)i).

For PSD, the directional gain calculation is following F)2)f)ii) of KDB 662911 D01 v02r01.

The power and PSD limit should be modified if the directional gain of EUT is over 6 dBi,

The directional gain "DG" is calculated as following table.

<CDD Modes>						
			DG for Power (dBi)	DG for PSD (dBi)	Power Limit Reduction (dB)	PSD Limit Reduction (dB)
	Ant. 4 (dBi)	Ant. 3 (dBi)				
2.4 GHz	0.40	-0.30	0.40	3.07	0.00	0.00

$Power\ Limit\ Reduction = DG(Power) - 6dBi, (min = 0)$

$PSD\ Limit\ Reduction = DG(PSD) - 6dBi, (min = 0)$



4 List of Measuring Equipment

Instrument	Manufacturer	Model No.	Serial No.	Characteristics	Calibration Date	Test Date	Due Date	Remark
Hygrometer	Testo	608-H2	41410069	N/A	Jun. 17, 2019	May 08, 2020~ May 29, 2020	Jun. 16, 2020	Conducted (TH05-HY)
Hygrometer	Testo	HTC-1	2	N/A	Mar. 02, 2020	Jun. 26, 2020	Mar. 01, 2021	Conducted (TH05-HY)
Power Sensor	DARE	RPR3006W	16I00054S NO10	10MHz~6GHz	Dec. 23, 2019	May 08, 2020~ Jun. 26, 2020	Dec. 22, 2020	Conducted (TH05-HY)
Power Supply	GW Instek	SPS-606	GES842931	NA	Aug. 19, 2019	May 08, 2020~ Jun. 26, 2020	Aug. 18, 2020	Conducted (TH05-HY)
Spectrum Analyzer	Rohde & Schwarz	FSP40	100055	9kHz-40GHz	Aug. 14, 2019	May 08, 2020~ Jun. 26, 2020	Aug. 13, 2020	Conducted (TH05-HY)
Switch Control Manframe	Burgeon	ETF-058	EC1300484	N/A	Aug. 22, 2019	May 08, 2020~ Jun. 26, 2020	Aug. 21, 2020	Conducted (TH05-HY)
AC Power Source	ChainTek	APC-1000W	N/A	N/A	N/A	May 19, 2020	N/A	Conduction (CO05-HY)
EMI Test Receiver	Rohde & Schwarz	ESR3	102388	9kHz~3.6GHz	Nov. 15, 2019	May 19, 2020	Nov. 14, 2020	Conduction (CO05-HY)
Hygrometer	Testo	608-H1	34913912	N/A	Nov. 07, 2019	May 19, 2020	Nov. 06, 2020	Conduction (CO05-HY)
LISN	Rohde & Schwarz	ENV216	100080	9kHz~30MHz	Nov. 20, 2019	May 19, 2020	Nov. 19, 2020	Conduction (CO05-HY)
LISN	Rohde & Schwarz	ENV216	100081	9kHz~30MHz	Nov. 15, 2019	May 19, 2020	Nov. 14, 2020	Conduction (CO05-HY)
Software	Rohde & Schwarz	EMC32 V10.30	N/A	N/A	N/A	May 19, 2020	N/A	Conduction (CO05-HY)
LF Cable	HUBER + SUHNER	RG-214/U	LF01	N/A	Jan. 02, 2020	May 19, 2020	Jan. 01, 2021	Conduction (CO05-HY)
Pulse Limiter	Rohde & Schwarz	ESH3-Z2	100851	N/A	Jan. 02, 2020	May 19, 2020	Jan. 01, 2021	Conduction (CO05-HY)
Bilog Antenna	TESEQ	CBL 6111D & 00800N1D0 1N-06	35419 & 03	30MHz~1GHz	Apr. 29, 2020	May 15, 2020~ Jun. 16, 2020	Apr. 28, 2021	Radiation (03CH07-HY)
Double Ridge Horn Antenna	ESCO	3117	00075962	1GHz ~ 18GHz	Dec. 06, 2019	May 15, 2020~ Jun. 16, 2020	Dec. 05, 2020	Radiation (03CH07-HY)
EMI Test Receiver	Agilent	N9038A(MX E)	MY5329005 3	20Hz~26.5GHz	Jan. 18, 2020	May 15, 2020~ Jun. 16, 2020	Jan. 17, 2021	Radiation (03CH07-HY)
Loop Antenna	Rohde & Schwarz	HFH2-Z2	100315	9 kHz~30 MHz	Dec. 26, 2019	May 15, 2020~ Jun. 16, 2020	Dec. 25, 2020	Radiation (03CH07-HY)
Preamplifier	MITEQ	AMF-7D-001 01800-30-10 P	1590075	1GHz~18GHz	Apr. 23, 2020	May 15, 2020~ Jun. 16, 2020	Apr. 22, 2021	Radiation (03CH07-HY)
Preamplifier	COM-POWER	PA-103A	161241	10MHz~1GHz	May 20, 2019	May 15, 2020~ May 18, 2020	May 19, 2020	Radiation (03CH07-HY)
Preamplifier	COM-POWER	PA-103A	161241	10MHz~1GHz	May 19, 2020	May 19, 2020~ Jun. 16, 2020	May 18, 2021	Radiation (03CH07-HY)
Preamplifier	Agilent	8449B	3008A0236 2	1GHz~26.5GHz	Nov. 01, 2019	May 15, 2020~ Jun. 16, 2020	Oct. 31, 2020	Radiation (03CH07-HY)
RF Cable	HUBER + SUHNER	SUCOFLEX 102	MY2858/2,8 01606/2	18GHz~40GHz	Feb. 25, 2020	May 15, 2020~ Jun. 16, 2020	Feb. 24, 2021	Radiation (03CH07-HY)
RF Cable	HUBER + SUHNER	SUCOFLEX 104	MY24971/4, MY28655/4	9kHz~30MHz	Feb. 25, 2020	May 15, 2020~ Jun. 16, 2020	Feb. 24, 2021	Radiation (03CH07-HY)



Instrument	Manufacturer	Model No.	Serial No.	Characteristics	Calibration Date	Test Date	Due Date	Remark
RF Cable	HUBER + SUHNER	SUCOFLEX 104	MY28655/4, MY24971/4, MY15682/4	30MHz~1GHz	Feb. 25, 2020	May 15, 2020~ Jun. 16, 2020	Feb. 24, 2021	Radiation (03CH07-HY)
RF Cable	HUBER + SUHNER	SUCOFLEX 104	MY28655/4, MY24971/4, MY15682/4	1GHz~18GHz	Feb. 25, 2020	May 15, 2020~ Jun. 16, 2020	Feb. 24, 2021	Radiation (03CH07-HY)
Controller	ChainTek	Chaintek 3000	N/A	Control Turn table	N/A	May 15, 2020~ Jun. 16, 2020	N/A	Radiation (03CH07-HY)
Controller	Max-Full	MF7802	MF7802083 68	Control Ant Mast	N/A	May 15, 2020~ Jun. 16, 2020	N/A	Radiation (03CH07-HY)
Antenna Mast	Max-Full	MFA520BS	N/A	1m~4m	N/A	May 15, 2020~ Jun. 16, 2020	N/A	Radiation (03CH07-HY)
Turn Table	ChainTek	Chaintek 3000	N/A	0~360 Degree	N/A	May 15, 2020~ Jun. 16, 2020	N/A	Radiation (03CH07-HY)
USB Data Logger	TECPEL	TR-32	HE17XB249 5	N/A	N/A	May 15, 2020~ Jun. 16, 2020	N/A	Radiation (03CH07-HY)
Spectrum Analyzer	Keysight	N9010A	MY5420048 6	10Hz~44GHz	Oct. 28, 2019	May 15, 2020~ Jun. 16, 2020	Oct. 27, 2020	Radiation (03CH07-HY)
SHF-EHF Horn Antenna	SCHWARZBECK	BBHA 9170	BBHA91705 84	18GHz~40GHz	Dec. 10, 2019	May 15, 2020~ Jun. 16, 2020	Dec. 09, 2020	Radiation (03CH07-HY)
Software	Audix	E3 6.2009-8-24	N/A	N/A	N/A	May 15, 2020~ Jun. 16, 2020	N/A	Radiation (03CH07-HY)
Preamplifier	EMEC	EM18G40G	060715	18GHz~40GHz	Dec. 13, 2019	May 15, 2020~ Jun. 16, 2020	Dec. 12, 2020	Radiation (03CH07-HY)



5 Uncertainty of Evaluation

Uncertainty of Conducted Emission Measurement (150kHz ~ 30MHz)

Measuring Uncertainty for a Level of Confidence of 95% ($U = 2Uc(y)$)	2.3
---	-----

Uncertainty of Radiated Emission Measurement (30 MHz ~ 1000 MHz)

Measuring Uncertainty for a Level of Confidence of 95% ($U = 2Uc(y)$)	4.6
---	-----

Uncertainty of Radiated Emission Measurement (1000 MHz ~ 18000 MHz)

Measuring Uncertainty for a Level of Confidence of 95% ($U = 2Uc(y)$)	5.2
---	-----

Uncertainty of Radiated Emission Measurement (18000 MHz ~ 40000 MHz)

Measuring Uncertainty for a Level of Confidence of 95% ($U = 2Uc(y)$)	5.3
---	-----

Appendix A. Test Result of Conducted Test Items

Test Engineer:	Kathy Chen	Temperature:	20.1~22.2	°C
Test Date:	2020/05/08~2020/06/26	Relative Humidity:	45.7~58.8	%

TEST RESULTS DATA
6dB and 99% Occupied Bandwidth

2.4GHz Band MIMO										
Mod.	Data Rate	N _{Tx}	CH.	Freq. (MHz)	99% Occupied BW (MHz)		6dB BW (MHz)		6dB BW Limit (MHz)	Pass/Fail
					Ant 4	Ant 3	Ant 4	Ant 3		
11b	1Mbps	2	1	2412	14.15	13.85	9.00	8.56	0.50	Pass
11b	1Mbps	2	6	2437	14.15	14.05	9.04	8.56	0.50	Pass
11b	1Mbps	2	11	2462	14.20	13.95	8.56	8.56	0.50	Pass
11g	6Mbps	2	1	2412	16.85	16.80	15.48	15.72	0.50	Pass
11g	6Mbps	2	6	2437	17.20	17.05	16.00	16.28	0.50	Pass
11g	6Mbps	2	11	2462	17.00	16.75	16.04	15.68	0.50	Pass
HT20	MCS0	2	1	2412	18.05	18.00	16.00	16.08	0.50	Pass
HT20	MCS0	2	6	2437	18.30	18.25	16.92	16.88	0.50	Pass
HT20	MCS0	2	11	2462	18.15	17.80	16.92	15.68	0.50	Pass

TEST RESULTS DATA
Average Output Power

2.4GHz Band Single Antenna																
Mod.	Data Rate	N _{TX}	CH.	Freq. (MHz)	Average Conducted Power (dBm)			Conducted Power Limit (dBm)		DG (dBi)		EIRP Power (dBm)		EIRP Power Limit (dBm)		Pass /Fail
					Ant 4	Ant 3	SUM	Ant 4	Ant 3	Ant 4	Ant 3	Ant 4	Ant 3	Ant 4	Ant 3	
11b	1Mbps	1	1	2412	19.30	19.00		30.00	30.00	0.40	-0.30	19.70	18.70	36.00	36.00	Pass
11b	1Mbps	1	6	2437	19.30	19.30		30.00	30.00	0.40	-0.30	19.70	19.00	36.00	36.00	Pass
11b	1Mbps	1	11	2462	19.10	19.30		30.00	30.00	0.40	-0.30	19.50	19.00	36.00	36.00	Pass
11g	6Mbps	1	1	2412	17.10	17.00		30.00	30.00	0.40	-0.30	17.50	16.70	36.00	36.00	Pass
11g	6Mbps	1	6	2437	19.20	19.10		30.00	30.00	0.40	-0.30	19.60	18.80	36.00	36.00	Pass
11g	6Mbps	1	11	2462	17.80	17.80		30.00	30.00	0.40	-0.30	18.20	17.50	36.00	36.00	Pass
HT20	MCS0	1	1	2412	16.40	16.30		30.00	30.00	0.40	-0.30	16.80	16.00	36.00	36.00	Pass
HT20	MCS0	1	6	2437	19.30	19.30		30.00	30.00	0.40	-0.30	19.70	19.00	36.00	36.00	Pass
HT20	MCS0	1	11	2462	16.30	16.40		30.00	30.00	0.40	-0.30	16.70	16.10	36.00	36.00	Pass
VHT20	MCS0	1	1	2412	16.30	16.20		30.00	30.00	0.40	-0.30	16.70	15.90	36.00	36.00	Pass
VHT20	MCS0	1	6	2437	19.20	19.20		30.00	30.00	0.40	-0.30	19.60	18.90	36.00	36.00	Pass
VHT20	MCS0	1	11	2462	16.20	16.30		30.00	30.00	0.40	-0.30	16.60	16.00	36.00	36.00	Pass

2.4GHz Band MIMO																
Mod.	Data Rate	N _{TX}	CH.	Freq. (MHz)	Average Conducted Power (dBm)			Conducted Power Limit (dBm)		DG (dBi)		EIRP Power (dBm)		EIRP Power Limit (dBm)		Pass /Fail
					Ant 4	Ant 3	SUM	Ant 4	Ant 3	Ant 4	Ant 3	Ant 4	Ant 3	Ant 4	Ant 3	
11b	1Mbps	2	1	2412	19.40	19.10	22.26	30.00		0.40		22.66		36.00		Pass
11b	1Mbps	2	6	2437	19.40	19.40	22.41	30.00		0.40		22.81		36.00		Pass
11b	1Mbps	2	11	2462	19.20	19.40	22.31	30.00		0.40		22.71		36.00		Pass
11g	6Mbps	2	1	2412	17.20	17.10	20.16	30.00		0.40		20.56		36.00		Pass
11g	6Mbps	2	6	2437	19.30	19.20	22.26	30.00		0.40		22.66		36.00		Pass
11g	6Mbps	2	11	2462	17.90	17.90	20.91	30.00		0.40		21.31		36.00		Pass
HT20	MCS0	2	1	2412	16.50	16.40	19.46	30.00		0.40		19.86		36.00		Pass
HT20	MCS0	2	6	2437	19.40	19.40	22.41	30.00		0.40		22.81		36.00		Pass
HT20	MCS0	2	11	2462	16.40	16.50	19.46	30.00		0.40		19.86		36.00		Pass
VHT20	MCS0	2	1	2412	16.40	16.30	19.36	30.00		0.40		19.76		36.00		Pass
VHT20	MCS0	2	6	2437	19.30	19.30	22.31	30.00		0.40		22.71		36.00		Pass
VHT20	MCS0	2	11	2462	16.30	16.40	19.36	30.00		0.40		19.76		36.00		Pass

Note: Measured power (dBm) has offset with cable loss.

TEST RESULTS DATA
Peak Power Spectral Density

2.4GHz Band MIMO												
Mod.	Data Rate	N _{TX}	CH.	Freq. (MHz)	Peak PSD (dBm/3kHz)			DG (dBi)		Peak PSD Limit (dBm/3kHz)		Pass/Fail
					Ant 4	Ant 3	Worse + 3.01	Ant 4	Ant 3	Ant 4	Ant 3	
11b	1Mbps	2	1	2412	-2.72	-2.36	0.65	3.07		8.00		Pass
11b	1Mbps	2	6	2437	-2.70	-2.67	0.34	3.07		8.00		Pass
11b	1Mbps	2	11	2462	-2.72	-2.97	0.29	3.07		8.00		Pass
11g	6Mbps	2	1	2412	-7.84	-7.98	-4.83	3.07		8.00		Pass
11g	6Mbps	2	6	2437	-6.48	-6.53	-3.47	3.07		8.00		Pass
11g	6Mbps	2	11	2462	-7.23	-7.57	-4.22	3.07		8.00		Pass
HT20	MCS0	2	1	2412	-8.42	-8.57	-5.41	3.07		8.00		Pass
HT20	MCS0	2	6	2437	-5.74	-5.87	-2.73	3.07		8.00		Pass
HT20	MCS0	2	11	2462	-8.33	-8.42	-5.32	3.07		8.00		Pass

Note: Measured power density (dBm) has offset with cable loss.



Appendix B. AC Conducted Emission Test Results

Test Engineer :	Howard Huang	Temperature :	21~25°C
		Relative Humidity :	42~45%

EUT Information

Report NO : 022521-02
 Test Mode : Mode 1
 Test Voltage : 120Vac/60Hz
 Phase : Line

Full Spectrum

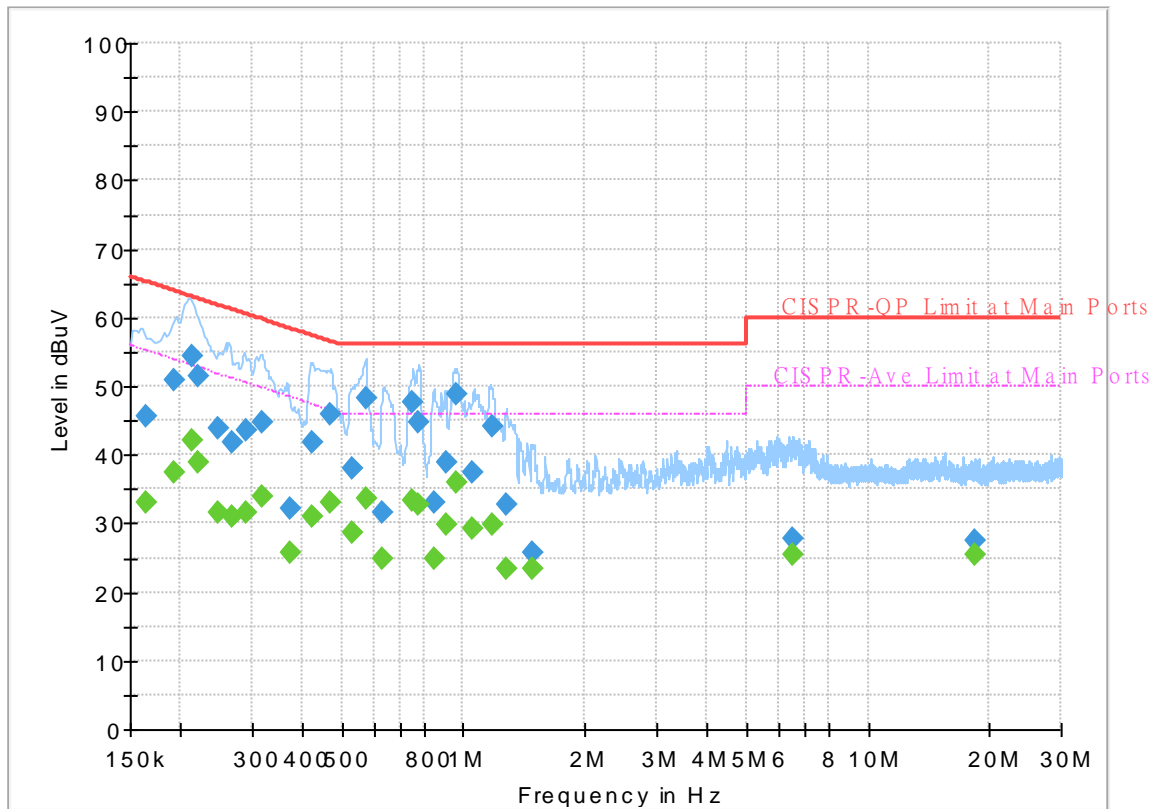

Final_Result

Frequency (MHz)	QuasiPeak (dBuV)	CAverage (dBuV)	Limit (dBuV)	Margin (dB)	Line	Filter	Corr. (dB)
0.163410	---	33.07	55.29	22.22	L1	OFF	19.6
0.163410	45.66	---	65.29	19.63	L1	OFF	19.6
0.193560	---	37.31	53.88	16.57	L1	OFF	19.6
0.193560	50.82	---	63.88	13.06	L1	OFF	19.6
0.213000	---	42.17	53.09	10.92	L1	OFF	19.6
0.213000	54.41	---	63.09	8.68	L1	OFF	19.6
0.219750	---	38.94	52.83	13.89	L1	OFF	19.6
0.219750	51.50	---	62.83	11.33	L1	OFF	19.6
0.249000	---	31.67	51.79	20.12	L1	OFF	19.6
0.249000	43.82	---	61.79	17.97	L1	OFF	19.6
0.267000	---	30.95	51.21	20.26	L1	OFF	19.6
0.267000	41.94	---	61.21	19.27	L1	OFF	19.6
0.291750	---	31.45	50.47	19.02	L1	OFF	19.6
0.291750	43.43	---	60.47	17.04	L1	OFF	19.6
0.318750	---	33.83	49.74	15.91	L1	OFF	19.6
0.318750	44.63	---	59.74	15.11	L1	OFF	19.6
0.372750	---	25.75	48.44	22.69	L1	OFF	19.6
0.372750	32.23	---	58.44	26.21	L1	OFF	19.6
0.420720	---	31.14	47.43	16.29	L1	OFF	19.6
0.420720	41.79	---	57.43	15.64	L1	OFF	19.6
0.471390	---	33.14	46.49	13.35	L1	OFF	19.6

0.471390	46.01	---	56.49	10.48	L1	OFF	19.6
0.529710	---	28.53	46.00	17.47	L1	OFF	19.6
0.529710	38.02	---	56.00	17.98	L1	OFF	19.6
0.574710	---	33.52	46.00	12.48	L1	OFF	19.6
0.574710	48.21	---	56.00	7.79	L1	OFF	19.6
0.631500	---	24.77	46.00	21.23	L1	OFF	19.6
0.631500	31.46	---	56.00	24.54	L1	OFF	19.6
0.749040	---	33.33	46.00	12.67	L1	OFF	19.6
0.749040	47.67	---	56.00	8.33	L1	OFF	19.6
0.771000	---	32.68	46.00	13.32	L1	OFF	19.6
0.771000	44.70	---	56.00	11.30	L1	OFF	19.6
0.846060	---	24.89	46.00	21.11	L1	OFF	19.6
0.846060	33.03	---	56.00	22.97	L1	OFF	19.6
0.906000	---	29.85	46.00	16.15	L1	OFF	19.6
0.906000	39.02	---	56.00	16.98	L1	OFF	19.6
0.965670	---	35.93	46.00	10.07	L1	OFF	19.6
0.965670	48.88	---	56.00	7.12	L1	OFF	19.6
1.056120	---	29.33	46.00	16.67	L1	OFF	19.6
1.056120	37.54	---	56.00	18.46	L1	OFF	19.6
1.185000	---	29.83	46.00	16.17	L1	OFF	19.6
1.185000	44.05	---	56.00	11.95	L1	OFF	19.6
1.279050	---	23.51	46.00	22.49	L1	OFF	19.6
1.279050	32.74	---	56.00	23.26	L1	OFF	19.6
1.485510	---	23.41	46.00	22.59	L1	OFF	19.6
1.485510	25.65	---	56.00	30.35	L1	OFF	19.6
6.537750	---	25.50	50.00	24.50	L1	OFF	19.9
6.537750	27.75	---	60.00	32.25	L1	OFF	19.9
18.390750	---	25.47	50.00	24.53	L1	OFF	20.3
18.390750	27.45	---	60.00	32.55	L1	OFF	20.3

EUT Information

Report NO : 022521-02
 Test Mode : Mode 1
 Test Voltage : 120Vac/60Hz
 Phase : Neutral

Full Spectrum

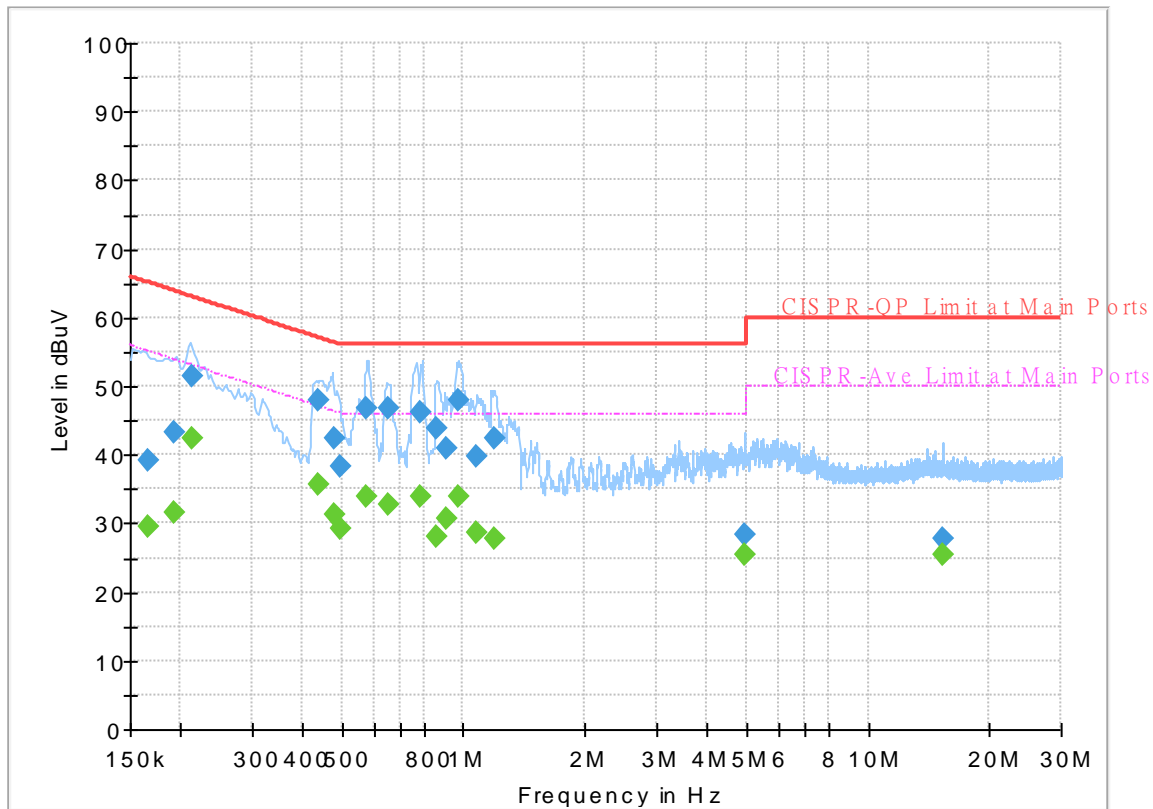

Final_Result

Frequency (MHz)	QuasiPeak (dBuV)	CAverage (dBuV)	Limit (dBuV)	Margin (dB)	Line	Filter	Corr. (dB)
0.165750	---	29.53	55.17	25.64	N	OFF	19.6
0.165750	39.09	---	65.17	26.08	N	OFF	19.6
0.193380	---	31.63	53.89	22.26	N	OFF	19.6
0.193380	43.22	---	63.89	20.67	N	OFF	19.6
0.213000	---	42.41	53.09	10.68	N	OFF	19.6
0.213000	51.50	---	63.09	11.59	N	OFF	19.6
0.435750	---	35.79	47.14	11.35	N	OFF	19.6
0.435750	47.89	---	57.14	9.25	N	OFF	19.6
0.478050	---	31.24	46.37	15.13	N	OFF	19.6
0.478050	42.49	---	56.37	13.88	N	OFF	19.6
0.494700	---	29.13	46.09	16.96	N	OFF	19.6
0.494700	38.43	---	56.09	17.66	N	OFF	19.6
0.573900	---	33.99	46.00	12.01	N	OFF	19.6
0.573900	46.71	---	56.00	9.29	N	OFF	19.6
0.651750	---	32.71	46.00	13.29	N	OFF	19.6
0.651750	46.78	---	56.00	9.22	N	OFF	19.6
0.786750	---	34.01	46.00	11.99	N	OFF	19.6
0.786750	46.32	---	56.00	9.68	N	OFF	19.6
0.860550	---	27.95	46.00	18.05	N	OFF	19.6
0.860550	43.84	---	56.00	12.16	N	OFF	19.6
0.902670	---	30.57	46.00	15.43	N	OFF	19.6

0.902670	41.01	---	56.00	14.99	N	OFF	19.6
0.970170	---	33.98	46.00	12.02	N	OFF	19.6
0.970170	47.84	---	56.00	8.16	N	OFF	19.6
1.077000	---	28.71	46.00	17.29	N	OFF	19.6
1.077000	39.69	---	56.00	16.31	N	OFF	19.6
1.189500	---	27.64	46.00	18.36	N	OFF	19.6
1.189500	42.51	---	56.00	13.49	N	OFF	19.6
4.959060	---	25.57	46.00	20.43	N	OFF	19.8
4.959060	28.46	---	56.00	27.54	N	OFF	19.8
15.242280	---	25.55	50.00	24.45	N	OFF	20.2
15.242280	27.77	---	60.00	32.23	N	OFF	20.2



Appendix C. Radiated Spurious Emission

Test Engineer :	Jesse Wang, Stan Hsieh and Ken Wu	Temperature :	21~23°C
		Relative Humidity :	50~57%

2.4GHz 2400~2483.5MHz
WIFI 802.11b (Band Edge @ 3m)

WIFI Ant.	Note	Frequency (MHz)	Level (dBμV/m)	Over Limit (dB)	Limit Line (dBμV/m)	Read Level (dBμV)	Antenna Factor (dB/m)	Path Loss (dB)	Preamp Factor (dB)	Ant Pos (cm)	Table Pos (deg)	Peak Avg. (P/A)	Pol. (H/V)	
802.11b CH 01 2412MHz		2386.965	56.75	-17.25	74	42.2	31.8	17.98	35.23	357	193	P	H	
		2385.285	48.23	-5.77	54	33.66	31.83	17.97	35.23	357	193	A	H	
	*	2412	111.81	-	-	97.17	31.87	18.02	35.25	357	193	P	H	
	*	2412	108.89	-	-	94.25	31.87	18.02	35.25	357	193	A	H	
													H	
			2385.285	54.94	-19.06	74	40.37	31.83	17.97	35.23	316	110	P	V
			2390	44.51	-9.49	54	29.96	31.8	17.98	35.23	316	110	A	V
	*		2412	107.36	-	-	92.72	31.87	18.02	35.25	316	110	P	V
	*		2412	104.24	-	-	89.6	31.87	18.02	35.25	316	110	A	V
														V
802.11b CH 06 2437MHz		2331.14	53.74	-20.26	74	39.2	31.87	17.87	35.2	345	193	P	H	
		2389.66	44.23	-9.77	54	29.68	31.8	17.98	35.23	345	193	A	H	
	*	2437	112.21	-	-	97.42	32	18.05	35.26	345	193	P	H	
	*	2437	109.03	-	-	94.24	32	18.05	35.26	345	193	A	H	
			2485.16	53.97	-20.03	74	39.07	32.07	18.12	35.29	345	193	P	H
			2483.76	44.3	-9.7	54	29.4	32.07	18.12	35.29	345	193	A	H
			2348.78	53.78	-20.22	74	39.19	31.9	17.9	35.21	348	111	P	V
			2389.52	43.48	-10.52	54	28.93	31.8	17.98	35.23	348	111	A	V
	*		2437	108.84	-	-	94.05	32	18.05	35.26	348	111	P	V
	*		2437	105.73	-	-	90.94	32	18.05	35.26	348	111	A	V
			2490.76	54.28	-19.72	74	39.34	32.1	18.13	35.29	348	111	P	V
			2483.5	43.89	-10.11	54	28.99	32.07	18.12	35.29	348	111	A	V



802.11b CH 11 2462MHz	*	2462	110.43	-	-	95.59	32.03	18.09	35.28	297	192	P	H
	*	2462	107.03	-	-	92.19	32.03	18.09	35.28	297	192	A	H
		2492.16	55.28	-18.72	74	40.35	32.1	18.13	35.3	297	192	P	H
		2483.52	47.86	-6.14	54	32.96	32.07	18.12	35.29	297	192	A	H
													H
													H
	*	2462	108.28	-	-	93.44	32.03	18.09	35.28	389	114	P	V
	*	2462	105.15	-	-	90.31	32.03	18.09	35.28	389	114	A	V
		2485.32	55.06	-18.94	74	40.16	32.07	18.12	35.29	389	114	P	V
		2483.52	45.09	-8.91	54	30.19	32.07	18.12	35.29	389	114	A	V
													V
													V
Remark	1. No other spurious found. 2. All results are PASS against Peak and Average limit line.												



**2.4GHz 2400~2483.5MHz
WIFI 802.11b (Harmonic @ 3m)**

WIFI Ant. 4+3	Note	Frequency (MHz)	Level (dBµV/m)	Over Limit (dB)	Limit Line (dBµV/m)	Read Level (dBµV)	Antenna Factor (dB/m)	Path Loss (dB)	Preamp Factor (dB)	Ant Pos (cm)	Table Pos (deg)	Peak Avg. (P/A)	Pol. (H/V)	
802.11b CH 01 2412MHz		4824	43.18	-30.82	74	56.03	34.05	11.99	58.89	100	0	P	H	
													H	
													H	
													H	
			4824	44.19	-29.81	74	57.04	34.05	11.99	58.89	100	0	P	V
														V
														V
802.11b CH 06 2437MHz		4874	43.42	-30.58	74	56.02	34.1	12.06	58.76	100	0	P	H	
		7311	46.06	-27.94	74	53.35	35.6	14.58	57.47	100	0	P	H	
													H	
													H	
			4874	43.24	-30.76	74	55.84	34.1	12.06	58.76	100	0	P	V
			7311	46.8	-27.2	74	54.09	35.6	14.58	57.47	100	0	P	V
														V
802.11b CH 11 2462MHz		4924	44.38	-29.62	74	56.66	34.23	12.13	58.64	100	0	P	H	
		7386	46.53	-27.47	74	53.83	35.6	14.64	57.54	100	0	P	H	
													H	
													H	
			4924	42.84	-31.16	74	55.12	34.23	12.13	58.64	100	0	P	V
			7386	46.51	-27.49	74	53.81	35.6	14.64	57.54	100	0	P	V
														V
Remark	1. No other spurious found.													
	2. All results are PASS against Peak and Average limit line.													



**2.4GHz 2400~2483.5MHz
WIFI 802.11g (Band Edge @ 3m)**

WIFI Ant. 4+3	Note	Frequency (MHz)	Level (dBμV/m)	Over Limit (dB)	Limit Line (dBμV/m)	Read Level (dBμV)	Antenna Factor (dB/m)	Path Loss (dB)	Preamp Factor (dB)	Ant Pos (cm)	Table Pos (deg)	Peak Avg. (P/A)	Pol. (H/V)	
802.11g CH 01 2412MHz		2389.695	64.44	-9.56	74	49.89	31.8	17.98	35.23	362	138	P	H	
		2390	51.11	-2.89	54	36.56	31.8	17.98	35.23	362	138	A	H	
	*	2412	111.79	-	-	97.15	31.87	18.02	35.25	362	138	P	H	
	*	2412	104.32	-	-	89.68	31.87	18.02	35.25	362	138	A	H	
													H	
														H
			2390	61.52	-12.48	74	46.97	31.8	17.98	35.23	323	102	P	V
			2390	50.48	-3.52	54	35.93	31.8	17.98	35.23	323	102	A	V
	*		2412	109.8	-	-	95.16	31.87	18.02	35.25	323	102	P	V
	*		2412	101.98	-	-	87.34	31.87	18.02	35.25	323	102	A	V
														V
														V
802.11g CH 06 2437MHz		2388.4	54.71	-19.29	74	40.16	31.8	17.98	35.23	347	192	P	H	
		2389.94	45.01	-8.99	54	30.46	31.8	17.98	35.23	347	192	A	H	
	*	2437	114.9	-	-	100.11	32	18.05	35.26	347	192	P	H	
	*	2437	107.73	-	-	92.94	32	18.05	35.26	347	192	A	H	
			2484.67	56.21	-17.79	74	41.31	32.07	18.12	35.29	347	192	P	H
			2483.55	45.09	-8.91	54	30.19	32.07	18.12	35.29	347	192	A	H
			2381.4	54.65	-19.35	74	40.08	31.83	17.97	35.23	395	111	P	V
			2389.94	43.5	-10.5	54	28.95	31.8	17.98	35.23	395	111	A	V
	*		2437	112.72	-	-	97.93	32	18.05	35.26	395	111	P	V
	*		2437	105.74	-	-	90.95	32	18.05	35.26	395	111	A	V
			2488.38	54.13	-19.87	74	39.19	32.1	18.13	35.29	395	111	P	V
			2499.65	43.78	-10.22	54	28.84	32.1	18.14	35.3	395	111	A	V



802.11g CH 11 2462MHz	*	2462	113.51	-	-	98.67	32.03	18.09	35.28	306	177	P	H
	*	2462	103.05	-	-	88.21	32.03	18.09	35.28	306	177	A	H
		2483.56	61.87	-12.13	74	46.97	32.07	18.12	35.29	306	177	P	H
		2483.52	51.12	-2.88	54	36.22	32.07	18.12	35.29	306	177	A	H
													H
													H
	*	2462	111.22	-	-	96.38	32.03	18.09	35.28	390	70	P	V
	*	2462	103.8	-	-	88.96	32.03	18.09	35.28	390	70	A	V
		2484.32	60.91	-13.09	74	46.01	32.07	18.12	35.29	390	70	P	V
		2483.52	49.12	-4.88	54	34.22	32.07	18.12	35.29	390	70	A	V
													V
													V
Remark	1. No other spurious found. 2. All results are PASS against Peak and Average limit line.												



**2.4GHz 2400~2483.5MHz
WIFI 802.11g (Harmonic @ 3m)**

WIFI Ant. 4+3	Note	Frequency (MHz)	Level (dBμV/m)	Over Limit (dB)	Limit Line (dBμV/m)	Read Level (dBμV)	Antenna Factor (dB/m)	Path Loss (dB)	Preamp Factor (dB)	Ant Pos (cm)	Table Pos (deg)	Peak Avg. (P/A)	Pol. (H/V)	
802.11g CH 01 2412MHz		4824	41.56	-32.44	74	54.41	34.05	11.99	58.89	100	0	P	H	
													H	
													H	
													H	
			4824	40.69	-33.31	74	53.54	34.05	11.99	58.89	100	0	P	V
														V
														V
802.11g CH 06 2437MHz		4874	43.38	-30.62	74	55.98	34.1	12.06	58.76	100	0	P	H	
		7311	44.82	-29.18	74	52.11	35.6	14.58	57.47	100	0	P	H	
													H	
													H	
			4874	41.86	-32.14	74	54.46	34.1	12.06	58.76	100	0	P	V
			7311	46.08	-27.92	74	53.37	35.6	14.58	57.47	100	0	P	V
														V
802.11g CH 11 2462MHz		4924	41.4	-32.6	74	53.68	34.23	12.13	58.64	100	0	P	H	
		7386	46.83	-27.17	74	54.13	35.6	14.64	57.54	100	0	P	H	
													H	
													H	
			4924	41.07	-32.93	74	53.35	34.23	12.13	58.64	100	0	P	V
			7386	45	-29	74	52.3	35.6	14.64	57.54	100	0	P	V
														V
Remark	1. No other spurious found.													
	2. All results are PASS against Peak and Average limit line.													



2.4GHz 2400~2483.5MHz
WIFI 802.11n HT20 (Band Edge @ 3m)

WIFI Ant. 4+3	Note	Frequency (MHz)	Level (dBμV/m)	Over Limit (dB)	Limit Line (dBμV/m)	Read Level (dBμV)	Antenna Factor (dB/m)	Path Loss (dB)	Preamp Factor (dB)	Ant Pos (cm)	Table Pos (deg)	Peak Avg. (P/A)	Pol. (H/V)	
802.11n HT20 CH 01 2412MHz		2389.905	62.88	-11.12	74	48.33	31.8	17.98	35.23	359	142	P	H	
		2390	51.77	-2.23	54	37.22	31.8	17.98	35.23	359	142	A	H	
	*	2412	110.08	-	-	95.44	31.87	18.02	35.25	359	142	P	H	
	*	2412	101.63	-	-	86.99	31.87	18.02	35.25	359	142	A	H	
													H	
														H
			2388.54	56.92	-17.08	74	42.37	31.8	17.98	35.23	399	69	P	V
			2390	48.02	-5.98	54	33.47	31.8	17.98	35.23	399	69	A	V
		*	2412	109.22	-	-	94.58	31.87	18.02	35.25	399	69	P	V
		*	2412	101.57	-	-	86.93	31.87	18.02	35.25	399	69	A	V
													V	
													V	
802.11n HT20 CH 06 2437MHz		2388.26	54.34	-19.66	74	39.79	31.8	17.98	35.23	345	194	P	H	
		2389.8	45.6	-8.4	54	31.05	31.8	17.98	35.23	345	194	A	H	
	*	2437	114.05	-	-	99.26	32	18.05	35.26	345	194	P	H	
	*	2437	106.83	-	-	92.04	32	18.05	35.26	345	194	A	H	
			2483.76	55.42	-18.58	74	40.52	32.07	18.12	35.29	345	194	P	H
			2483.69	45.61	-8.39	54	30.71	32.07	18.12	35.29	345	194	A	H
			2382.24	53.96	-20.04	74	39.39	31.83	17.97	35.23	396	113	P	V
			2380.7	44.25	-9.75	54	29.68	31.83	17.97	35.23	396	113	A	V
		*	2437	113.25	-	-	98.46	32	18.05	35.26	396	113	P	V
		*	2437	105.27	-	-	90.48	32	18.05	35.26	396	113	A	V
		2488.45	54.29	-19.71	74	39.35	32.1	18.13	35.29	396	113	P	V	
		2498.6	44.71	-9.29	54	29.77	32.1	18.14	35.3	396	113	A	V	



802.11n HT20 CH 11 2462MHz	*	2462	110.56	-	-	95.72	32.03	18.09	35.28	339	143	P	H
	*	2462	103.12	-	-	88.28	32.03	18.09	35.28	339	143	A	H
		2483.72	60.66	-13.34	74	45.76	32.07	18.12	35.29	339	143	P	H
		2483.52	52.05	-1.95	54	37.15	32.07	18.12	35.29	339	143	A	H
													H
													H
	*	2462	107.85	-	-	93.01	32.03	18.09	35.28	388	71	P	V
	*	2462	99.62	-	-	84.78	32.03	18.09	35.28	388	71	A	V
		2484.12	57.97	-16.03	74	43.07	32.07	18.12	35.29	388	71	P	V
		2483.84	48.55	-5.45	54	33.65	32.07	18.12	35.29	388	71	A	V
													V
													V
Remark	1. No other spurious found. 2. All results are PASS against Peak and Average limit line.												



**2.4GHz 2400~2483.5MHz
WIFI 802.11n HT20 (Harmonic @ 3m)**

WIFI Ant. 4+3	Note	Frequency (MHz)	Level (dBμV/m)	Over Limit (dB)	Limit Line (dBμV/m)	Read Level (dBμV)	Antenna Factor (dB/m)	Path Loss (dB)	Preamp Factor (dB)	Ant Pos (cm)	Table Pos (deg)	Peak Avg. (P/A)	Pol. (H/V)	
802.11n HT20 CH 01 2412MHz		4824	41.38	-32.62	74	54.23	34.05	11.99	58.89	100	0	P	H	
													H	
													H	
													H	
			4824	41.73	-32.27	74	54.58	34.05	11.99	58.89	100	0	P	V
														V
														V
802.11n HT20 CH 06 2437MHz		4874	42.1	-31.9	74	54.7	34.1	12.06	58.76	100	0	P	H	
													H	
			7311	45.35	-28.65	74	52.64	35.6	14.58	57.47	100	0	P	H
														H
			4874	42.72	-31.28	74	55.32	34.1	12.06	58.76	100	0	P	V
			7311	45.39	-28.61	74	52.68	35.6	14.58	57.47	100	0	P	V
														V
802.11n HT20 CH 11 2462MHz		4924	41.19	-32.81	74	53.47	34.23	12.13	58.64	100	0	P	H	
													H	
			7386	42.46	-31.54	74	49.76	35.6	14.64	57.54	100	0	P	H
														H
			4924	41.7	-32.3	74	53.98	34.23	12.13	58.64	100	0	P	V
			7386	43.26	-30.74	74	50.56	35.6	14.64	57.54	100	0	P	V
														V
Remark	1. No other spurious found.													
	2. All results are PASS against Peak and Average limit line.													



**Emission above 18GHz
2.4GHz WIFI 802.11n HT20 (SHF)**

WIFI	Note	Frequency	Level	Over	Limit	Read	Antenna	Path	Preamp	Ant	Table	Peak	Pol.	
Ant.				Limit	Line	Level	Factor	Loss	Factor	Pos	Pos	Avg.		
4+3		(MHz)	(dBμV/m)	(dB)	(dBμV/m)	(dBμV)	(dB/m)	(dB)	(dB)	(cm)	(deg)	(P/A)	(H/V)	
2.4GHz 802.11n HT20 SHF		24111	35.41	-38.59	74	42.45	39.75	6.56	53.35	150	0	P	H	
													H	
													H	
													H	
													H	
													H	
			24125	36.3	-37.7	74	43.33	39.75	6.57	53.35	150	0	P	V
														V
														V
														V
Remark	1. No other spurious found. 2. All results are PASS against limit line.													



Emission below 1GHz
2.4GHz WIFI 802.11n HT20 (LF)

WIFI	Note	Frequency	Level	Over	Limit	Read	Antenna	Path	Preamp	Ant	Table	Peak	Pol.	
Ant.				Limit	Line	Level	Factor	Loss	Factor	Pos	Pos	Avg.		
4+3		(MHz)	(dBμV/m)	(dB)	(dBμV/m)	(dBμV)	(dB/m)	(dB)	(dB)	(cm)	(deg)	(P/A)	(H/V)	
2.4GHz 802.11n HT20 LF		31.62	27.25	-12.75	40	32.74	23.57	0.95	30.01	-	-	P	H	
		40.8	22.82	-17.18	40	32.74	19	1.08	30	-	-	P	H	
		176.61	28.63	-14.87	43.5	41.19	15.15	2.23	29.94	-	-	P	H	
		783.7	30.86	-15.14	46	27.75	27.81	4.78	29.48	-	-	P	H	
		860.7	32.78	-13.22	46	28.06	28.9	4.99	29.17	-	-	P	H	
		950.3	33.76	-12.24	46	26.94	30.26	5.26	28.7	100	0	P	H	
													H	
													H	
													H	
													H	
													H	
													H	
													H	
													H	
			30.27	33.55	-6.45	40	38.31	24.32	0.93	30.01	100	0	P	V
			43.77	25.93	-14.07	40	37.61	17.2	1.12	30	-	-	P	V
			52.95	23.11	-16.89	40	38.73	13.14	1.23	29.99	-	-	P	V
			767.6	30.74	-15.26	46	27.76	27.79	4.71	29.52	-	-	P	V
			879.6	32.86	-13.14	46	27.99	28.91	5.05	29.09	-	-	P	V
			959.4	33.56	-12.44	46	26.51	30.41	5.29	28.65	-	-	P	V
													V	
													V	
													V	
													V	
													V	
													V	
Remark	1. No other spurious found. 2. All results are PASS against limit line.													



Note symbol

*	Fundamental Frequency which can be ignored. However, the level of any unwanted emissions shall not exceed the level of the fundamental frequency.
!	Test result is over limit line.
P/A	Peak or Average
H/V	Horizontal or Vertical



A calculation example for radiated spurious emission is shown as below:

WIFI	Note	Frequency	Level	Over	Limit	Read	Antenna	Path	Preamp	Ant	Table	Peak	Pol.
Ant.				Limit	Line	Level	Factor	Loss	Factor	Pos	Pos	Avg.	
4+3		(MHz)	(dBμV/m)	(dB)	(dBμV/m)	(dBμV)	(dB/m)	(dB)	(dB)	(cm)	(deg)	(P/A)	(H/V)
802.11b		2390	55.45	-18.55	74	54.51	32.22	4.58	35.86	103	308	P	H
CH 01													
2412MHz		2390	43.54	-10.46	54	42.6	32.22	4.58	35.86	103	308	A	H

1. Path Loss(dB) = Cable loss(dB) + Filter loss(dB) + Attenuator loss(dB)
2. Level(dBμV/m) =
Antenna Factor(dB/m) + Path Loss(dB) + Read Level(dBμV) - Preamp Factor(dB)
3. Over Limit(dB) = Level(dBμV/m) – Limit Line(dBμV/m)

For Peak Limit @ 2390MHz:

1. Level(dBμV/m)
= Antenna Factor(dB/m) + Path Loss(dB) + Read Level(dBμV) - Preamp Factor(dB)
= 32.22(dB/m) + 4.58(dB) + 54.51(dBμV) – 35.86 (dB)
= 55.45 (dBμV/m)
2. Over Limit(dB)
= Level(dBμV/m) – Limit Line(dBμV/m)
= 55.45(dBμV/m) – 74(dBμV/m)
= -18.55(dB)

For Average Limit @ 2390MHz:

1. Level(dBμV/m)
= Antenna Factor(dB/m) + Path Loss(dB) + Read Level(dBμV) - Preamp Factor(dB)
= 32.22(dB/m) + 4.58(dB) + 42.6(dBμV) – 35.86 (dB)
= 43.54 (dBμV/m)
2. Over Limit(dB)
= Level(dBμV/m) – Limit Line(dBμV/m)
= 43.54(dBμV/m) – 54(dBμV/m)
= -10.46(dB)

Both peak and average measured complies with the limit line, so test result is “PASS”.



Appendix D. Radiated Spurious Emission Plots

Test Engineer :	Jesse Wang, Stan Hsieh and Ken Wu	Temperature :	21~23°C
		Relative Humidity :	50~57%

Note symbol

-L	Low channel location
-R	High channel location

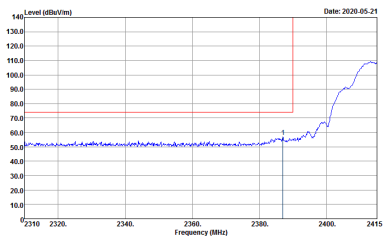
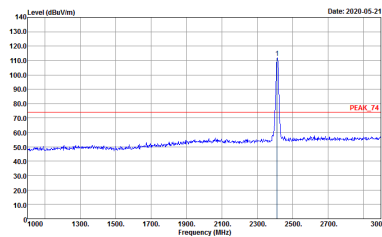
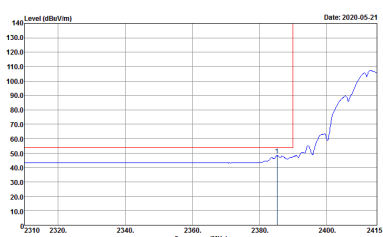
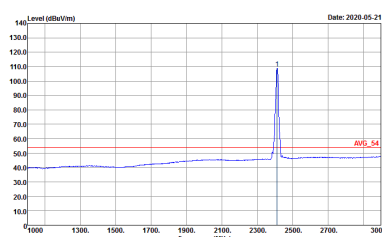

2.4GHz 2400~2483.5MHz
WIFI 802.11b (Band Edge @ 3m)

WIFI	2.4GHz 2400~2483.5MHz Band Edge @ 3m	
ANT	802.11b CH01 2412MHz	
4+3	Horizontal	Fundamental
Peak	 <p>Site : 03CH07-HY Condition : PEAK_BE_74 3m HF_ANT_00075962 HORIZONTAL Detector : Peak Project : 022521-02 Mode : 13</p>	 <p>Site : 03CH07-HY Condition : PEAK_74 3m HF_ANT_00075962 HORIZONTAL Detector : Peak Project : 022521-02 Mode : 13</p>
Avg.	 <p>Site : 03CH07-HY Condition : AVG_BE_54 3m HF_ANT_00075962 HORIZONTAL Detector : Peak Project : 022521-02 Mode : 13</p>	 <p>Site : 03CH07-HY Condition : AVG_54 3m HF_ANT_00075962 HORIZONTAL Detector : Peak Project : 022521-02 Mode : 13</p>

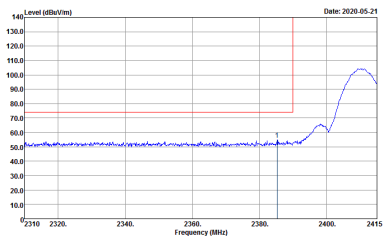
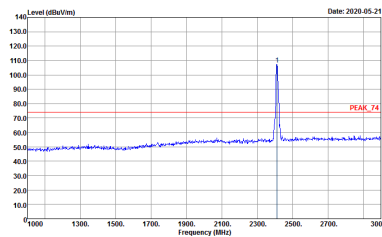
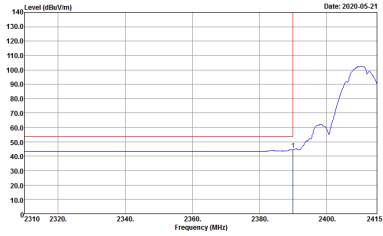
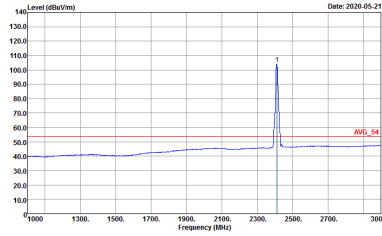

WIFI	2.4GHz 2400~2483.5MHz Band Edge @ 3m	
ANT	802.11b CH01 2412MHz	
4+3	Vertical	Fundamental
Peak	 <p>Date: 2020-05-21</p> <p>Site : 03CH07-HY Condition : PEAK_BE_74 3m HF_ANT_00075962 VERTICAL : RBW:1000.000kHz VBW:3000.000kHz SWT:Auto Detector : Peak Project : 022521-02 Mode : 13</p>	 <p>Date: 2020-05-21</p> <p>Site : 03CH07-HY Condition : PEAK_74 3m HF_ANT_00075962 VERTICAL : RBW:1000.000kHz VBW:3000.000kHz SWT:Auto Detector : Peak Project : 022521-02 Mode : 13</p>
Avg.	 <p>Date: 2020-05-21</p> <p>Site : 03CH07-HY Condition : AVG_BE_54 3m HF_ANT_00075962 VERTICAL : RBW:1000.000kHz VBW:3000.000kHz SWT:Auto Detector : Peak Project : 022521-02 Mode : 13</p>	 <p>Date: 2020-05-21</p> <p>Site : 03CH07-HY Condition : AVG_54 3m HF_ANT_00075962 VERTICAL : RBW:1000.000kHz VBW:3000.000kHz SWT:Auto Detector : Peak Project : 022521-02 Mode : 13</p>

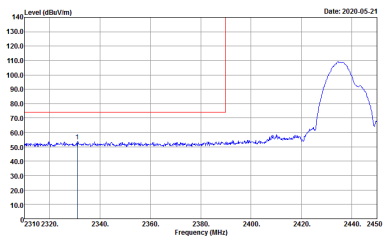
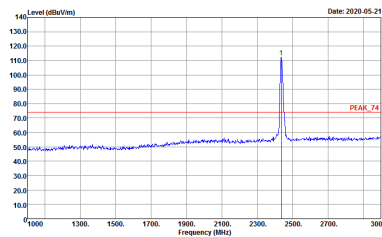
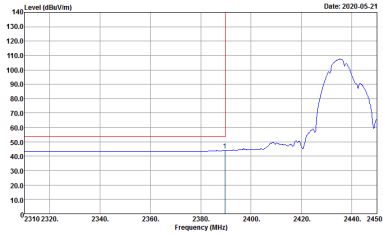
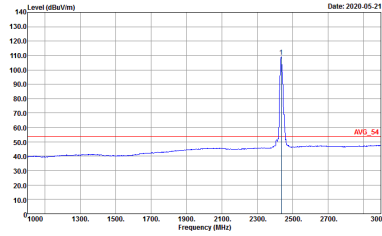

WIFI	2.4GHz 2400~2483.5MHz Band Edge @ 3m	
ANT	802.11b CH06 2437MHz - L	
4+3	Horizontal	Fundamental
Peak	 <p>Date: 2020-05-21</p> <p>Site : 03CH07-HY Condition : PEAK_BE_74 3m HF_ANT_00075962 HORIZONTAL RBW:1000.000kHz VBW:3000.000kHz SWT:Auto Detector : Peak Project : 022521-02 Mode : 14</p>	 <p>Date: 2020-05-21</p> <p>Site : 03CH07-HY Condition : PEAK_74 3m HF_ANT_00075962 HORIZONTAL RBW:1000.000kHz VBW:3000.000kHz SWT:Auto Detector : Peak Project : 022521-02 Mode : 14</p>
Avg.	 <p>Date: 2020-05-21</p> <p>Site : 03CH07-HY Condition : AVG_BE_54 3m HF_ANT_00075962 HORIZONTAL RBW:1000.000kHz VBW:3000.000kHz SWT:Auto Detector : Peak Project : 022521-02 Mode : 14</p>	 <p>Date: 2020-05-21</p> <p>Site : 03CH07-HY Condition : AVG_54 3m HF_ANT_00075962 HORIZONTAL RBW:1000.000kHz VBW:3000.000kHz SWT:Auto Detector : Peak Project : 022521-02 Mode : 14</p>

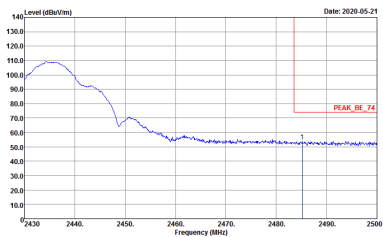
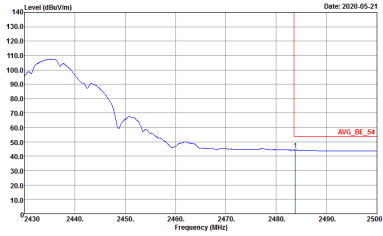

WIFI	2.4GHz 2400~2483.5MHz Band Edge @ 3m	
ANT	802.11b CH06 2437MHz - R	
4+3	Horizontal	Fundamental
<p>Peak</p>	 <p>Date: 2020-05-21</p> <p>Site : 03CH07-HY Condition : PEAK_BE_74 3m HF_ANT_00075962 HORIZONTAL Detector : Peak Project : 022521-02 Mode : 14</p>	<p>Left blank</p>
<p>Avg.</p>	 <p>Date: 2020-05-21</p> <p>Site : 03CH07-HY Condition : AVG_BE_54 3m HF_ANT_00075962 HORIZONTAL Detector : Peak Project : 022521-02 Mode : 14</p>	<p>Left blank</p>

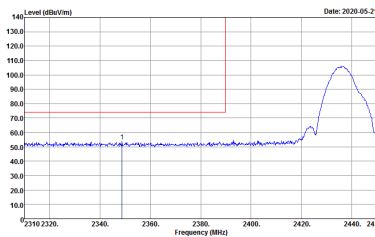
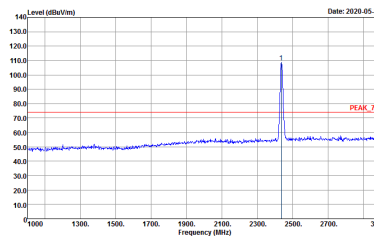
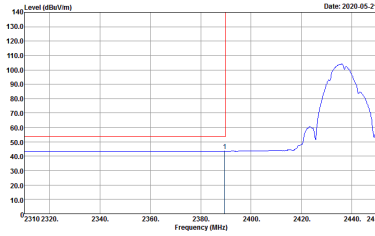
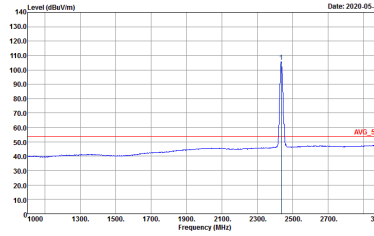

WIFI	2.4GHz 2400~2483.5MHz Band Edge @ 3m	
ANT	802.11b CH06 2437MHz - L	
4+3	Vertical	Fundamental
Peak	 <p>Site : 03CH07-HY Condition : PEAK_BE_74 3m HF_ANT_00075962 VERTICAL : RBW:1000.000kHz VBW:3000.000kHz SWT:Auto Detector : Peak Project : 022521-02 Mode : 14</p>	 <p>Site : 03CH07-HY Condition : PEAK_74 3m HF_ANT_00075962 VERTICAL : RBW:1000.000kHz VBW:3000.000kHz SWT:Auto Detector : Peak Project : 022521-02 Mode : 14</p>
Avg.	 <p>Site : 03CH07-HY Condition : AVG_BE_54 3m HF_ANT_00075962 VERTICAL : RBW:1000.000kHz VBW:3000.000kHz SWT:Auto Detector : Peak Project : 022521-02 Mode : 14</p>	 <p>Site : 03CH07-HY Condition : AVG_54 3m HF_ANT_00075962 VERTICAL : RBW:1000.000kHz VBW:3000.000kHz SWT:Auto Detector : Peak Project : 022521-02 Mode : 14</p>

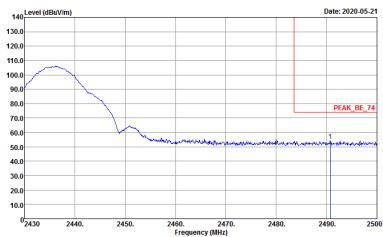
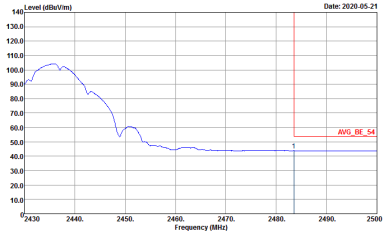

WIFI	2.4GHz 2400~2483.5MHz Band Edge @ 3m	
ANT	802.11b CH06 2437MHz - R	
4+3	Vertical	Fundamental
<p>Peak</p>	 <p>Date: 2020-05-21</p> <p>Site : 03CH07-HY Condition : PEAK_BE_74 3m HF_ANT_00075962 VERTICAL Detector : Peak Project : 022521-02 Mode : 14</p>	<p>Left blank</p>
<p>Avg.</p>	 <p>Date: 2020-05-21</p> <p>Site : 03CH07-HY Condition : AVG_BE_54 3m HF_ANT_00075962 VERTICAL Detector : Peak Project : 022521-02 Mode : 14</p>	<p>Left blank</p>

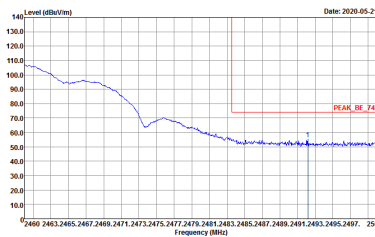
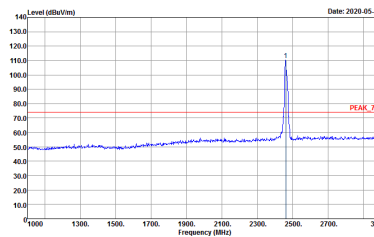
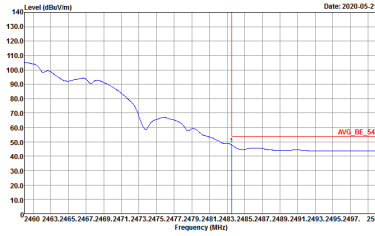
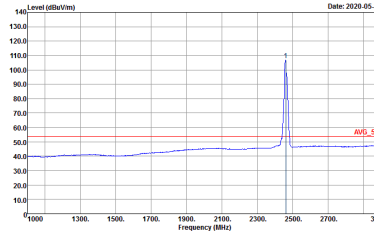

WIFI	2.4GHz 2400~2483.5MHz Band Edge @ 3m	
ANT	802.11b CH11 2462MHz	
4+3	Horizontal	Fundamental
<p>Peak</p>	 <p>Date: 2020-05-21</p> <p>Level (dBm/Vm)</p> <p>Frequency (MHz)</p> <p>PEAK_BE_74</p> <p>Site : 03CH07-HY Condition : PEAK_BE_74 3m HF_ANT_00075962 HORIZONTAL RBW:1000.000kHz VBW:3000.000kHz SWT:Auto Detector : Peak Project : 022521-02 Mode : 15</p>	 <p>Date: 2020-05-21</p> <p>Level (dBm/Vm)</p> <p>Frequency (MHz)</p> <p>PEAK_74</p> <p>Site : 03CH07-HY Condition : PEAK_74 3m HF_ANT_00075962 HORIZONTAL RBW:1000.000kHz VBW:3000.000kHz SWT:Auto Detector : Peak Project : 022521-02 Mode : 15</p>
<p>Avg.</p>	 <p>Date: 2020-05-21</p> <p>Level (dBm/Vm)</p> <p>Frequency (MHz)</p> <p>AVG_BE_54</p> <p>Site : 03CH07-HY Condition : AVG_BE_54 3m HF_ANT_00075962 HORIZONTAL RBW:1000.000kHz VBW:0.010kHz SWT:Auto Detector : Peak Project : 022521-02 Mode : 15</p>	 <p>Date: 2020-05-21</p> <p>Level (dBm/Vm)</p> <p>Frequency (MHz)</p> <p>AVG_54</p> <p>Site : 03CH07-HY Condition : AVG_54 3m HF_ANT_00075962 HORIZONTAL RBW:1000.000kHz VBW:0.010kHz SWT:Auto Detector : Peak Project : 022521-02 Mode : 15</p>



WIFI	2.4GHz 2400~2483.5MHz Band Edge @ 3m	
ANT	802.11b CH11 2462MHz	
4+3	Vertical	Fundamental
<p>Peak</p>	<p>Site : 03CH07-HY Condition : PEAK_BE_74 3m HF_ANT_00075962 VERTICAL Detector : Peak Project : 022521-02 Mode : 15</p>	<p>Site : 03CH07-HY Condition : PEAK_74 3m HF_ANT_00075962 VERTICAL Detector : Peak Project : 022521-02 Mode : 15</p>
<p>Avg.</p>	<p>Site : 03CH07-HY Condition : AVG_BE_54 3m HF_ANT_00075962 VERTICAL Detector : Peak Project : 022521-02 Mode : 15</p>	<p>Site : 03CH07-HY Condition : AVG_54 3m HF_ANT_00075962 VERTICAL Detector : Peak Project : 022521-02 Mode : 15</p>



2.4GHz 2400~2483.5MHz
WIFI 802.11g (Band Edge @ 3m)

WIFI	2.4GHz 2400~2483.5MHz Band Edge @ 3m	
ANT	802.11g CH01 2412MHz	
4+3	Horizontal	Fundamental
Peak	<p>Site : 03CH07-HY Condition : PEAK_BE_74 3m HF_ANT_00075962 HORIZONTAL Detector : Peak Project : 022521-02 Mode : 16</p>	<p>Site : 03CH07-HY Condition : PEAK_74 3m HF_ANT_00075962 HORIZONTAL Detector : Peak Project : 022521-02 Mode : 16</p>
Avg.	<p>Site : 03CH07-HY Condition : AVG_BE_54 3m HF_ANT_00075962 HORIZONTAL Detector : Peak Project : 022521-02 Mode : 16</p>	<p>Site : 03CH07-HY Condition : AVG_54 3m HF_ANT_00075962 HORIZONTAL Detector : Peak Project : 022521-02 Mode : 16</p>

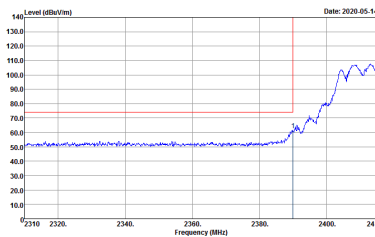
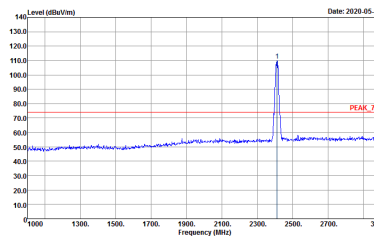
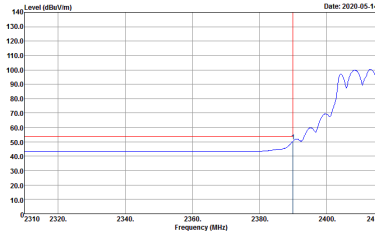
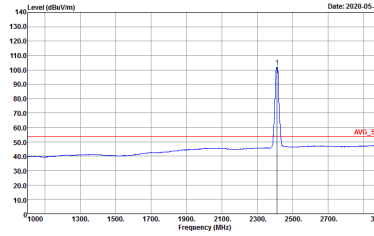

WIFI	2.4GHz 2400~2483.5MHz Band Edge @ 3m	
ANT	802.11g CH01 2412MHz	
4+3	Vertical	Fundamental
Peak	 <p>Date: 2020-05-14</p> <p>Site : 03CH07-HY Condition : PEAK_BE_74 3m HF_ANT_00075962 VERTICAL : RBW:1000.000KHz VBW:3000.000KHz SWT:Auto Detector : Peak Project : 022521-02 Mode : 16</p>	 <p>Date: 2020-05-14</p> <p>Site : 03CH07-HY Condition : PEAK_74 3m HF_ANT_00075962 VERTICAL : RBW:1000.000KHz VBW:3000.000KHz SWT:Auto Detector : Peak Project : 022521-02 Mode : 16</p>
Avg.	 <p>Date: 2020-05-14</p> <p>Site : 03CH07-HY Condition : AVG_BE_54 3m HF_ANT_00075962 VERTICAL : RBW:1000.000KHz VBW:0.010KHz SWT:Auto Detector : Peak Project : 022521-02 Mode : 16</p>	 <p>Date: 2020-05-14</p> <p>Site : 03CH07-HY Condition : AVG_54 3m HF_ANT_00075962 VERTICAL : RBW:1000.000KHz VBW:0.010KHz SWT:Auto Detector : Peak Project : 022521-02 Mode : 16</p>

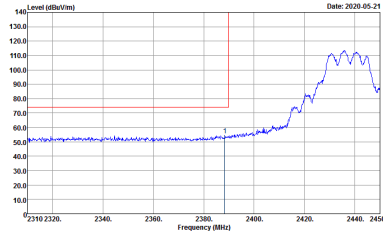
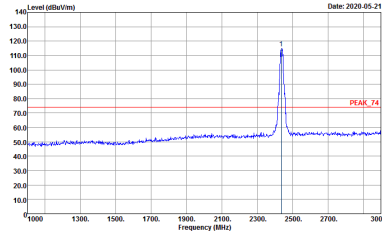
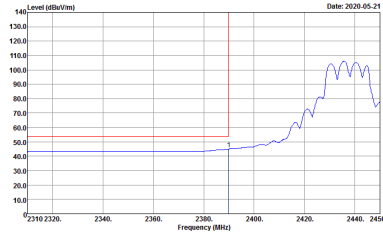
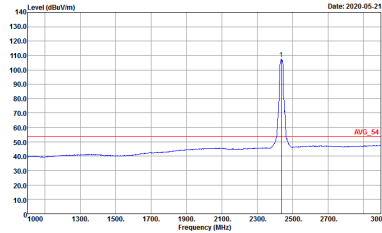

WIFI	2.4GHz 2400~2483.5MHz Band Edge @ 3m	
ANT	802.11g CH06 2437MHz - L	
4+3	Horizontal	Fundamental
Peak	 <p>Site : 03CH07-HY Condition : PEAK_BE_74 3m HF_ANT_00075962 HORIZONTAL Detector : RBW:1000.000kHz VBW:3000.000kHz SWT:Auto Project : 022521-02 Mode : 17</p>	 <p>Site : 03CH07-HY Condition : PEAK_74 3m HF_ANT_00075962 HORIZONTAL Detector : RBW:1000.000kHz VBW:3000.000kHz SWT:Auto Project : 022521-02 Mode : 17</p>
Avg.	 <p>Site : 03CH07-HY Condition : AVG_BE_54 3m HF_ANT_00075962 HORIZONTAL Detector : RBW:1000.000kHz VBW:3000.000kHz SWT:Auto Project : 022521-02 Mode : 17</p>	 <p>Site : 03CH07-HY Condition : AVG_54 3m HF_ANT_00075962 HORIZONTAL Detector : RBW:1000.000kHz VBW:3000.000kHz SWT:Auto Project : 022521-02 Mode : 17</p>

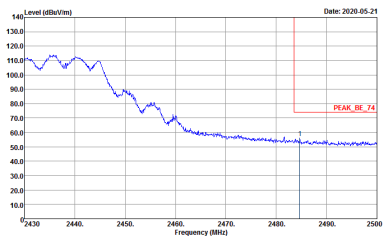
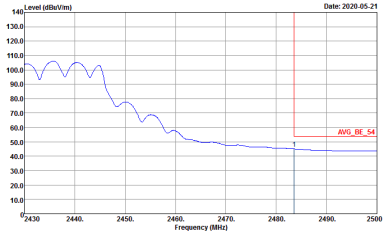

WIFI	2.4GHz 2400~2483.5MHz Band Edge @ 3m	
ANT	802.11g CH06 2437MHz - R	
4+3	Horizontal	Fundamental
Peak	 <p>Site : 03CH07-HY Condition : PEAK_BE_74 3m HF_ANT_00075962 HORIZONTAL Detector : Peak Project : 022521-02 Mode : 17</p>	Left blank
Avg.	 <p>Site : 03CH07-HY Condition : AVG_BE_54 3m HF_ANT_00075962 HORIZONTAL Detector : Peak Project : 022521-02 Mode : 17</p>	Left blank

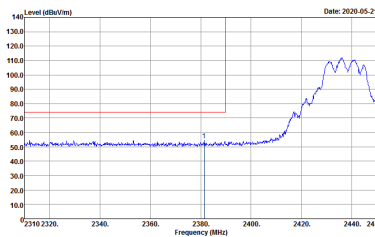
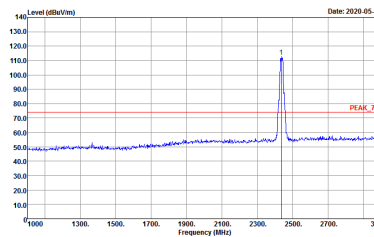
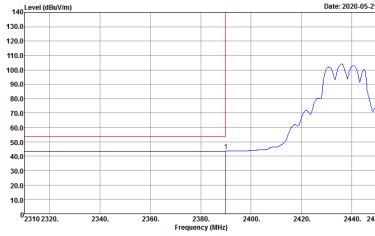
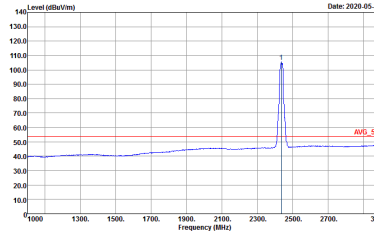

WIFI	2.4GHz 2400~2483.5MHz Band Edge @ 3m	
ANT	802.11g CH06 2437MHz - L	
4+3	Vertical	Fundamental
Peak	 <p>Date: 2020-05-21</p> <p>Site : 03CH07-HY Condition : PEAK_BE_74 3m HF_ANT_00075962 VERTICAL : RBW:1000.000kHz VBW:3000.000kHz SWT:Auto Detector : Peak Project : 022521-02 Mode : 17</p>	 <p>Date: 2020-05-21</p> <p>Site : 03CH07-HY Condition : PEAK_74 3m HF_ANT_00075962 VERTICAL : RBW:1000.000kHz VBW:3000.000kHz SWT:Auto Detector : Peak Project : 022521-02 Mode : 17</p>
Avg.	 <p>Date: 2020-05-21</p> <p>Site : 03CH07-HY Condition : AVG_BE_54 3m HF_ANT_00075962 VERTICAL : RBW:1000.000kHz VBW:0.010kHz SWT:Auto Detector : Peak Project : 022521-02 Mode : 17</p>	 <p>Date: 2020-05-21</p> <p>Site : 03CH07-HY Condition : AVG_54 3m HF_ANT_00075962 VERTICAL : RBW:1000.000kHz VBW:0.010kHz SWT:Auto Detector : Peak Project : 022521-02 Mode : 17</p>

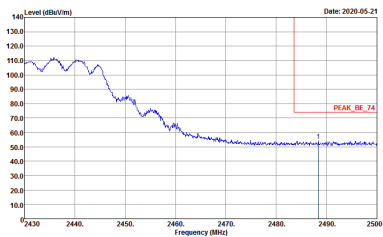
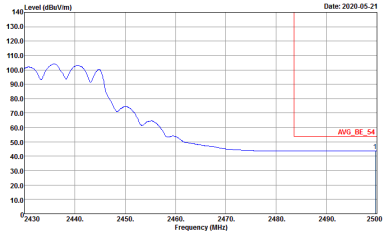

WIFI	2.4GHz 2400~2483.5MHz Band Edge @ 3m	
ANT	802.11g CH06 2437MHz - R	
4+3	Vertical	Fundamental
<p>Peak</p>	 <p>Date: 2020-05-21</p> <p>Site : 03CH07-HY Condition : PEAK_BE_74 3m HF_ANT_00075962 VERTICAL Detector : Peak Project : 022521-02 Mode : 17</p>	<p>Left Blank</p>
<p>Avg.</p>	 <p>Date: 2020-05-21</p> <p>Site : 03CH07-HY Condition : AVG_BE_54 3m HF_ANT_00075962 VERTICAL Detector : Peak Project : 022521-02 Mode : 17</p>	<p>Left Blank</p>



WIFI	2.4GHz 2400~2483.5MHz Band Edge @ 3m	
ANT	802.11g CH11 2462MHz	
4+3	Horizontal	Fundamental
<p>Peak</p>	<p>Site : 03CH07-HY Condition : PEAK_BE_74 3m HF_ANT_00075962 HORIZONTAL Detector : Peak Project : 022521-02 Mode : 18</p>	<p>Site : 03CH07-HY Condition : PEAK_74 3m HF_ANT_00075962 HORIZONTAL Detector : Peak Project : 022521-02 Mode : 18</p>
<p>Avg.</p>	<p>Site : 03CH07-HY Condition : AVG_BE_54 3m HF_ANT_00075962 HORIZONTAL Detector : Peak Project : 022521-02 Mode : 18</p>	<p>Site : 03CH07-HY Condition : AVG_54 3m HF_ANT_00075962 HORIZONTAL Detector : Peak Project : 022521-02 Mode : 18</p>

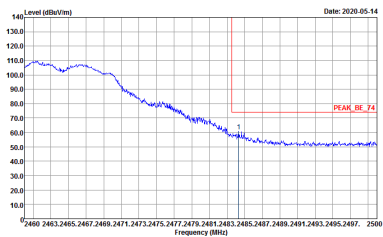
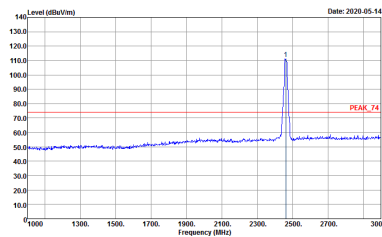
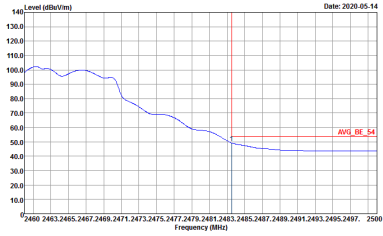
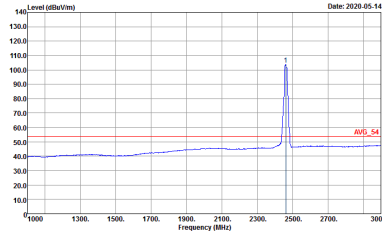

WIFI	2.4GHz 2400~2483.5MHz Band Edge @ 3m	
ANT	802.11g CH11 2462MHz	
4+3	Vertical	Fundamental
<p>Peak</p>	 <p>Site : 03CH07-HY Condition : PEAK_BE_74 3m HF_ANT_00075962 VERTICAL Detector : Peak Project : 022521-02 Mode : 18</p>	 <p>Site : 03CH07-HY Condition : PEAK_74 3m HF_ANT_00075962 VERTICAL Detector : Peak Project : 022521-02 Mode : 18</p>
<p>Avg.</p>	 <p>Site : 03CH07-HY Condition : AVG_BE_54 3m HF_ANT_00075962 VERTICAL Detector : Peak Project : 022521-02 Mode : 18</p>	 <p>Site : 03CH07-HY Condition : AVG_54 3m HF_ANT_00075962 VERTICAL Detector : Peak Project : 022521-02 Mode : 18</p>



2.4GHz 2400~2483.5MHz
WIFI 802.11n HT20 (Band Edge @ 3m)

WIFI	2.4GHz 2400~2483.5MHz Band Edge @ 3m	
ANT	802.11n HT20 CH01 2412MHz	
4+3	Horizontal	Fundamental
Peak	<p>Site : 03CH07-HY Condition : PEAK_BE_74 3m HF_ANT_00075962 HORIZONTAL Detector : Peak Project : 022521-02 Mode : 19</p>	<p>Site : 03CH07-HY Condition : PEAK_74 3m HF_ANT_00075962 HORIZONTAL Detector : Peak Project : 022521-02 Mode : 19</p>
Avg.	<p>Site : 03CH07-HY Condition : AVG_BE_54 3m HF_ANT_00075962 HORIZONTAL Detector : Peak Project : 022521-02 Mode : 19</p>	<p>Site : 03CH07-HY Condition : AVG_54 3m HF_ANT_00075962 HORIZONTAL Detector : Peak Project : 022521-02 Mode : 19</p>

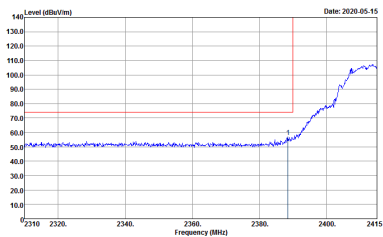
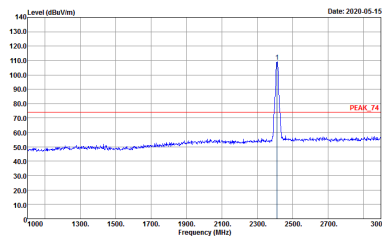
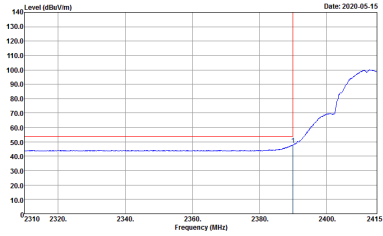
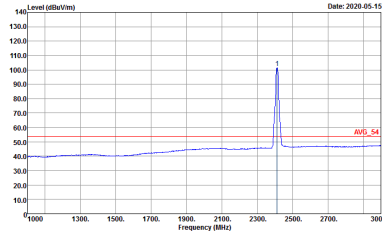

WIFI	2.4GHz 2400~2483.5MHz Band Edge @ 3m	
ANT	802.11n HT20 CH01 2412MHz	
4+3	Vertical	Fundamental
Peak	 <p>Site : 03CH07-HY Condition : PEAK_BE_74 3m HF_ANT_00075962 VERTICAL Detector : RBW:1000.000KHz VBW:3000.000KHz SWT:Auto Project : 022521-02 Mode : 19</p>	 <p>Site : 03CH07-HY Condition : PEAK_74 3m HF_ANT_00075962 VERTICAL Detector : RBW:1000.000KHz VBW:3000.000KHz SWT:Auto Project : 022521-02 Mode : 19</p>
Avg.	 <p>Site : 03CH07-HY Condition : AVG_BE_54 3m HF_ANT_00075962 VERTICAL Detector : RBW:1000.000KHz VBW:1.000KHz SWT:Auto Project : 022521-02 Mode : 19</p>	 <p>Site : 03CH07-HY Condition : AVG_54 3m HF_ANT_00075962 VERTICAL Detector : RBW:1000.000KHz VBW:1.000KHz SWT:Auto Project : 022521-02 Mode : 19</p>

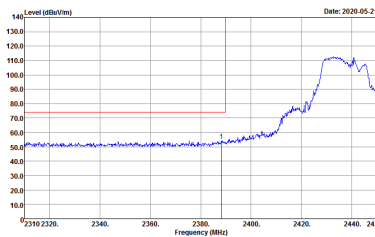
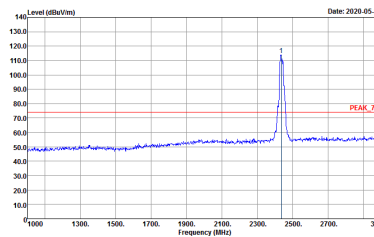
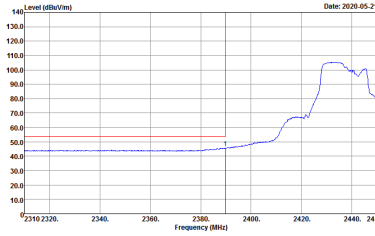
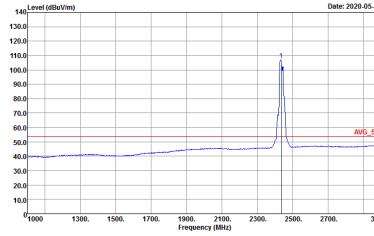

WIFI	2.4GHz 2400~2483.5MHz Band Edge @ 3m	
ANT	802.11n HT20 CH06 2437MHz - L	
4+3	Horizontal	Fundamental
Peak	 <p>Date: 2020-05-21</p> <p>Site : 03CH07-HY Condition : PEAK_BE_74 3m HF_ANT_00075962 HORIZONTAL RBW:1000.000kHz VBW:3000.000kHz SWT:Auto Detector : Peak Project : 022521-02 Mode : 20</p>	 <p>Date: 2020-05-21</p> <p>Site : 03CH07-HY Condition : PEAK_74 3m HF_ANT_00075962 HORIZONTAL RBW:1000.000kHz VBW:3000.000kHz SWT:Auto Detector : Peak Project : 022521-02 Mode : 20</p>
Avg.	 <p>Date: 2020-05-21</p> <p>Site : 03CH07-HY Condition : AVG_BE_54 3m HF_ANT_00075962 HORIZONTAL RBW:1000.000kHz VBW:1.000kHz SWT:Auto Detector : Peak Project : 022521-02 Mode : 20</p>	 <p>Date: 2020-05-21</p> <p>Site : 03CH07-HY Condition : AVG_54 3m HF_ANT_00075962 HORIZONTAL RBW:1000.000kHz VBW:1.000kHz SWT:Auto Detector : Peak Project : 022521-02 Mode : 20</p>

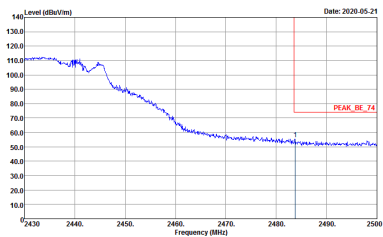
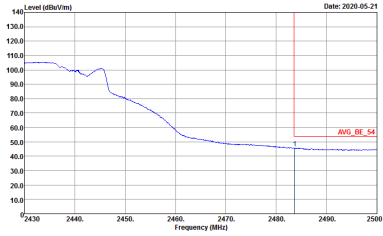

WIFI	2.4GHz 2400~2483.5MHz Band Edge @ 3m	
ANT	802.11n HT20 CH06 2437MHz - R	
4+3	Horizontal	Fundamental
<p>Peak</p>	 <p>Date: 2020-05-21</p> <p>Site : 03CH07-HY Condition : PEAK_BE_74 3m HF_ANT_00075962 HORIZONTAL Detector : Peak Project : 022521-02 Mode : 20</p>	<p>Left blank</p>
<p>Avg.</p>	 <p>Date: 2020-05-21</p> <p>Site : 03CH07-HY Condition : AVG_BE_54 3m HF_ANT_00075962 HORIZONTAL Detector : Peak Project : 022521-02 Mode : 20</p>	<p>Left blank</p>

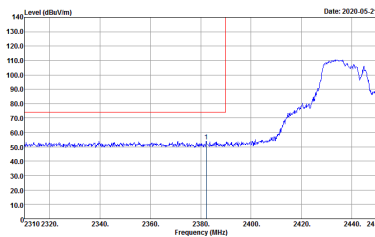
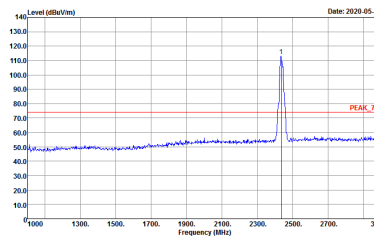
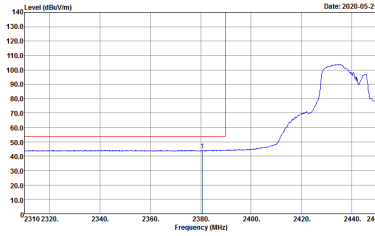
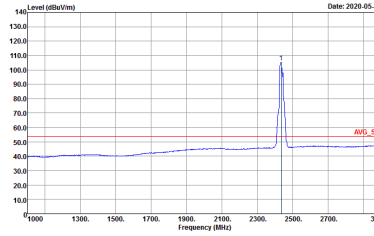

WIFI	2.4GHz 2400~2483.5MHz Band Edge @ 3m	
ANT	802.11n HT20 CH06 2437MHz - L	
4+3	Vertical	Fundamental
<p>Peak</p>	 <p>Date: 2020-05-21</p> <p>Site : 03CH07-HY Condition : PEAK_BE_74 3m HF_ANT_00075962 VERTICAL : RBW:1000.000kHz VBW:3000.000kHz SWT:Auto Detector : Peak Project : 022521-02 Mode : 20</p>	 <p>Date: 2020-05-21</p> <p>Site : 03CH07-HY Condition : PEAK_74 3m HF_ANT_00075962 VERTICAL : RBW:1000.000kHz VBW:3000.000kHz SWT:Auto Detector : Peak Project : 022521-02 Mode : 20</p>
<p>Avg.</p>	 <p>Date: 2020-05-21</p> <p>Site : 03CH07-HY Condition : AVG_BE_54 3m HF_ANT_00075962 VERTICAL : RBW:1000.000kHz VBW:1.000kHz SWT:Auto Detector : Peak Project : 022521-02 Mode : 20</p>	 <p>Date: 2020-05-21</p> <p>Site : 03CH07-HY Condition : AVG_54 3m HF_ANT_00075962 VERTICAL : RBW:1000.000kHz VBW:1.000kHz SWT:Auto Detector : Peak Project : 022521-02 Mode : 20</p>

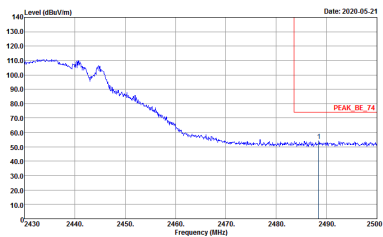
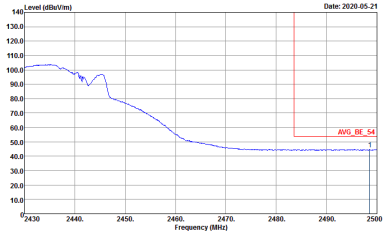

WIFI	2.4GHz 2400~2483.5MHz Band Edge @ 3m	
ANT	802.11n HT20 CH06 2437MHz - R	
4+3	Vertical	Fundamental
<p>Peak</p>	 <p>Date: 2020-05-21</p> <p>Site : 03CH07-HY Condition : PEAK_BE_74 3m HF_ANT_00075962 VERTICAL Detector : RBW:1000.000kHz VBW:3000.000kHz SWT:Auto Project : 022521-02 Mode : 20</p>	<p>Left Blank</p>
<p>Avg.</p>	 <p>Date: 2020-05-21</p> <p>Site : 03CH07-HY Condition : AVG_BE_54 3m HF_ANT_00075962 VERTICAL Detector : RBW:1000.000kHz VBW:1.000kHz SWT:Auto Project : 022521-02 Mode : 20</p>	<p>Left Blank</p>

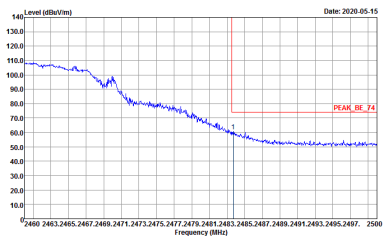
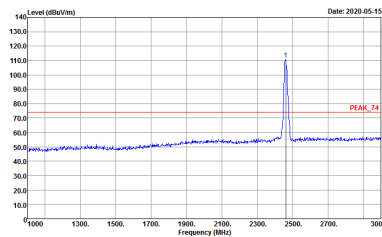
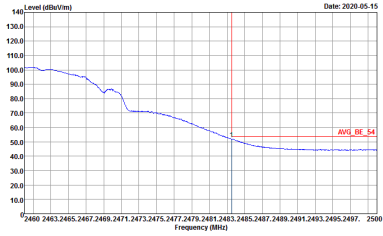
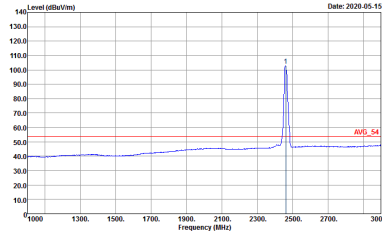

WIFI	2.4GHz 2400~2483.5MHz Band Edge @ 3m	
ANT	802.11n HT20 CH11 2462MHz	
4+3	Horizontal	Fundamental
Peak	 <p>Site : 03CH07-HY Condition : PEAK_BE_74 3m HF_ANT_00075962 HORIZONTAL Detector : Peak Project : 022521-02 Mode : Z1</p>	 <p>Site : 03CH07-HY Condition : PEAK_74 3m HF_ANT_00075962 HORIZONTAL Detector : Peak Project : 022521-02 Mode : Z1</p>
Avg.	 <p>Site : 03CH07-HY Condition : AVG_BE_54 3m HF_ANT_00075962 HORIZONTAL Detector : Peak Project : 022521-02 Mode : Z1</p>	 <p>Site : 03CH07-HY Condition : AVG_54 3m HF_ANT_00075962 HORIZONTAL Detector : Peak Project : 022521-02 Mode : Z1</p>

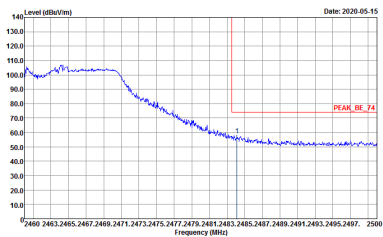
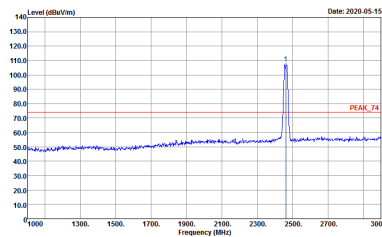
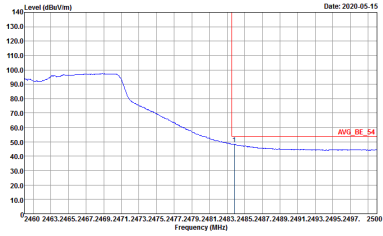
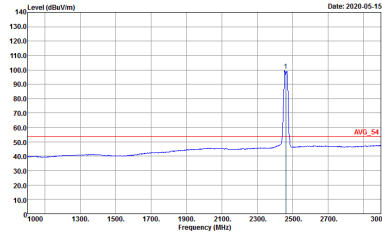

WIFI	2.4GHz 2400~2483.5MHz Fundamental @ 3m	
ANT	802.11n HT20 CH11 2462MHz	
4+3	Vertical	Fundamental
Peak	 <p>Site : 03CH07-HY Condition : PEAK_BE_74 3m HF_ANT_00075962 VERTICAL RBW:1000.000kHz VBW:3000.000kHz SWT:Auto Detector : Peak Project : 022521-02 Mode : Z1</p>	 <p>Site : 03CH07-HY Condition : PEAK_74 3m HF_ANT_00075962 VERTICAL RBW:1000.000kHz VBW:3000.000kHz SWT:Auto Detector : Peak Project : 022521-02 Mode : Z1</p>
Avg.	 <p>Site : 03CH07-HY Condition : AVG_BE_54 3m HF_ANT_00075962 VERTICAL RBW:1000.000kHz VBW:1.000kHz SWT:Auto Detector : Peak Project : 022521-02 Mode : Z1</p>	 <p>Site : 03CH07-HY Condition : AVG_54 3m HF_ANT_00075962 VERTICAL RBW:1000.000kHz VBW:1.000kHz SWT:Auto Detector : Peak Project : 022521-02 Mode : Z1</p>



2.4GHz 2400~2483.5MHz
WIFI 802.11b (Harmonic @ 3m)

WIFI	2.4GHz 2400~2483.5MHz Harmonic @ 3m	
ANT	802.11b CH01 2412MHz	
4+3	Horizontal	Vertical
Peak Avg.	<p>Site : 09CH07-HY Condition : PEAK_74 3m HF_ANT_00075962 HORIZONTAL Detector : Peak Project : 022521-02 Mode : 13</p>	<p>Site : 09CH07-HY Condition : PEAK_74 3m HF_ANT_00075962 VERTICAL Detector : Peak Project : 022521-02 Mode : 13</p>

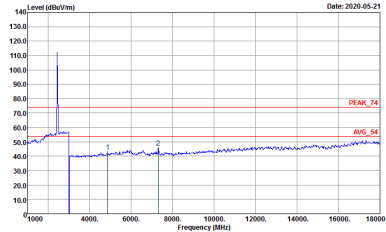
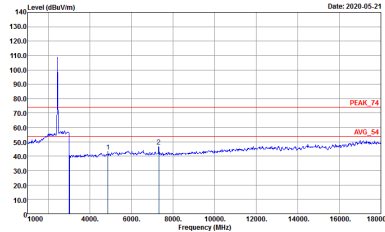

WIFI	2.4GHz 2400~2483.5MHz Harmonic @ 3m	
ANT	802.11b CH06 2437MHz	
4+3	Horizontal	Vertical
<p>Peak</p> <p>Avg.</p>	 <p>Site : E8CH07-HY Condition : PEAK_74 3m HE_ANT_00075962 HORIZONTAL Detector : Peak Project : 022521-02 Mode : 14</p>	 <p>Site : E8CH07-HY Condition : PEAK_74 3m HE_ANT_00075962 VERTICAL Detector : Peak Project : 022521-02 Mode : 14</p>



WIFI	2.4GHz 2400~2483.5MHz Harmonic @ 3m	
ANT	802.11b CH11 2462MHz	
4+3	Horizontal	Vertical
Peak Avg.	<p>Site : E3CH07-HY Condition : PEAK_74 3m HE_ANT_00075962 HORIZONTAL Detector : Peak Project : 022521-02 Mode : 15</p>	<p>Site : E3CH07-HY Condition : PEAK_74 3m HE_ANT_00075962 VERTICAL Detector : Peak Project : 022521-02 Mode : 15</p>



2.4GHz 2400~2483.5MHz
 WIFI 802.11g (Harmonic @ 3m)

WIFI	2.4GHz 2400~2483.5MHz Harmonic @ 3m	
ANT	802.11g CH01 2412MHz	
4+3	Horizontal	Vertical
Peak Avg.		



WIFI	2.4GHz 2400~2483.5MHz Harmonic @ 3m	
ANT	802.11g CH06 2437MHz	
4+3	Horizontal	Vertical
Peak Avg.	<p>Site : E8CH07-HY Condition : PEAK_74 3m HE_ANT_00075962 HORIZONTAL Detector : Peak Project : 022521-02 Mode : 17</p>	<p>Site : E8CH07-HY Condition : PEAK_74 3m HE_ANT_00075962 VERTICAL Detector : Peak Project : 022521-02 Mode : 17</p>



WIFI	2.4GHz 2400~2483.5MHz Harmonic @ 3m	
ANT	802.11g CH11 2462MHz	
4+3	Horizontal	Vertical
Peak Avg.	<p>Site : E3CH07-HY Condition : PEAK_74 3m HE_ANT_00075962 HORIZONTAL Detector : Peak Project : 022521-02 Mode : 18</p>	<p>Site : E3CH07-HY Condition : PEAK_74 3m HE_ANT_00075962 VERTICAL Detector : Peak Project : 022521-02 Mode : 18</p>



2.4GHz 2400~2483.5MHz
 WIFI 802.11n HT20 (Harmonic @ 3m)

WIFI	2.4GHz 2400~2483.5MHz Harmonic @ 3m	
ANT	802.11n HT20 CH01 2412MHz	
4+3	Horizontal	Vertical
Peak Avg.		

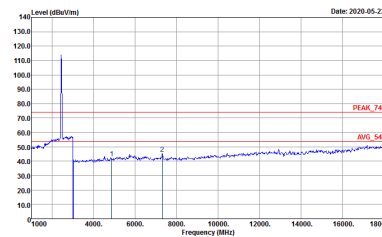
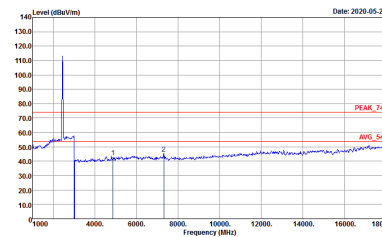

WIFI	2.4GHz 2400~2483.5MHz Harmonic @ 3m	
ANT	802.11n HT20 CH06 2437MHz	
4+3	Horizontal	Vertical
<p>Peak</p> <p>Avg.</p>	 <p>Site : E3CH07-HY Condition : PEAK_74 3m HE_ANT_00075962 HORIZONTAL Detector : Peak Project : 022521-02 Mode : 20</p>	 <p>Site : E3CH07-HY Condition : PEAK_74 3m HE_ANT_00075962 VERTICAL Detector : Peak Project : 022521-02 Mode : 20</p>



WIFI	2.4GHz 2400~2483.5MHz Harmonic @ 3m	
ANT	802.11n HT20 CH11 2462MHz	
4+3	Horizontal	Vertical
Peak Avg.	<p>Site : E8CH07-HY Condition : PEAK_74 3m HE_ANT_00075962 HORIZONTAL Detector : Peak Project : 022521-02 Mode : 21</p>	<p>Site : E8CH07-HY Condition : PEAK_74 3m HE_ANT_00075962 VERTICAL Detector : Peak Project : 022521-02 Mode : 21</p>



Emission above 18GHz
2.4GHz WIFI 802.11n HT20 (SHF)

WIFI	2.4GHz 2400~2483.5MHz	
ANT	802.11n HT20 SHF	
4+3	Horizontal	Vertical
Peak Avg.	<p>Site : 03CH07-HY Condition : PEAK_74 5m SHF-EHF_9170584 HORIZONTAL Detector : Peak Project : 022521-02 Mode : 27</p>	<p>Site : 03CH07-HY Condition : PEAK_74 5m SHF-EHF_9170584 VERTICAL Detector : Peak Project : 022521-02 Mode : 27</p>



Emission below 1GHz
2.4GHz WIFI 802.11n HT20 (LF)

WIFI	2.4GHz 2400~2483.5MHz	
ANT	802.11n HT20 LF	
4+3	Horizontal	Vertical
QP / Peak	<p>Site : 03CH07-HY Condition : QP 3m LF-ANT-35419(G) HORIZONTAL Detector : Peak Project : 022521-02 Mode : 22</p>	<p>Site : 03CH07-HY Condition : QP 3m LF-ANT-35419(G) VERTICAL Detector : Peak Project : 022521-02 Mode : 22</p>



Appendix E. Duty Cycle Plots

Antenna	Band	Duty Cycle(%)	T(us)	1/T(kHz)	VBW Setting	Duty Factor(dB)
4+3	802.11b for Ant 4	98.92	-	-	10Hz	0.05
4+3	802.11b for Ant 3	98.80	-	-	10Hz	0.05
4+3	802.11g for Ant 4	98.35	-	-	10Hz	0.07
4+3	802.11g for Ant 3	98.11	-	-	10Hz	0.08
4+3	2.4GHz 802.11n HT20 for Ant 4	97.72	1925	0.52	1kHz	0.10
4+3	2.4GHz 802.11n HT20 for Ant 3	97.47	1925	0.52	1kHz	0.11



MIMO <Ant. 4>

802.11b

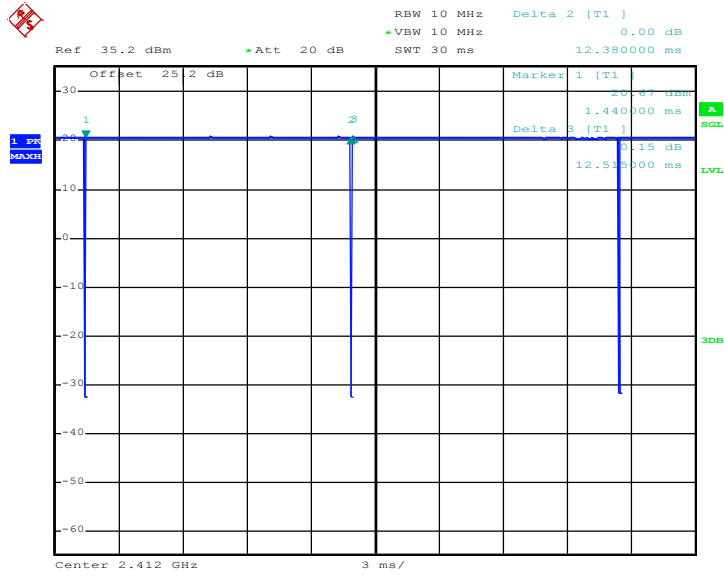

Date: 8.MAY.2020 13:53:36

802.11g

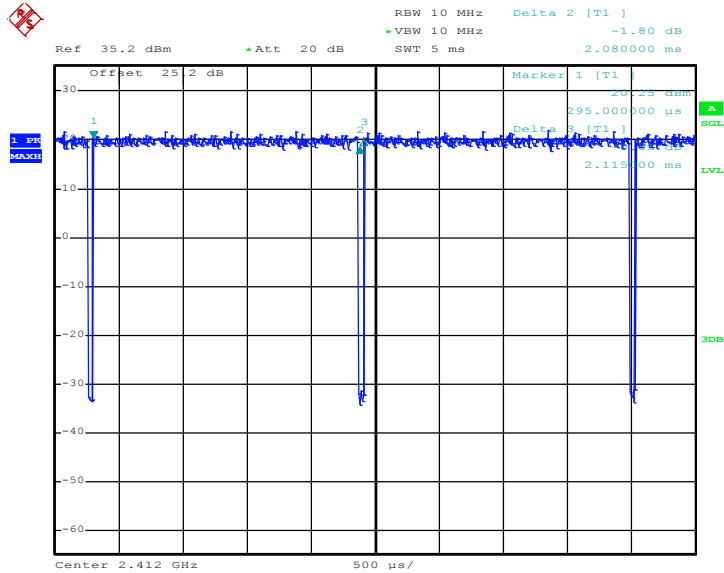

Date: 8.MAY.2020 13:56:48



802.11n HT20

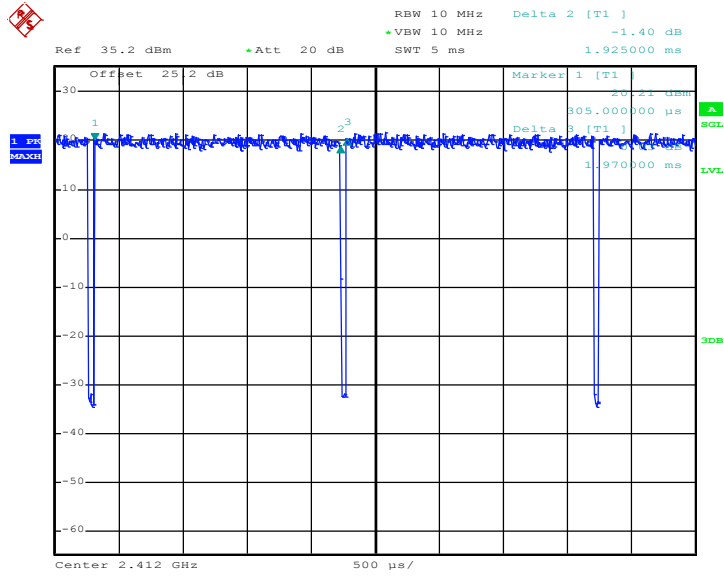

Date: 8.MAY.2020 14:08:37

MIMO <Ant. 3>

802.11b

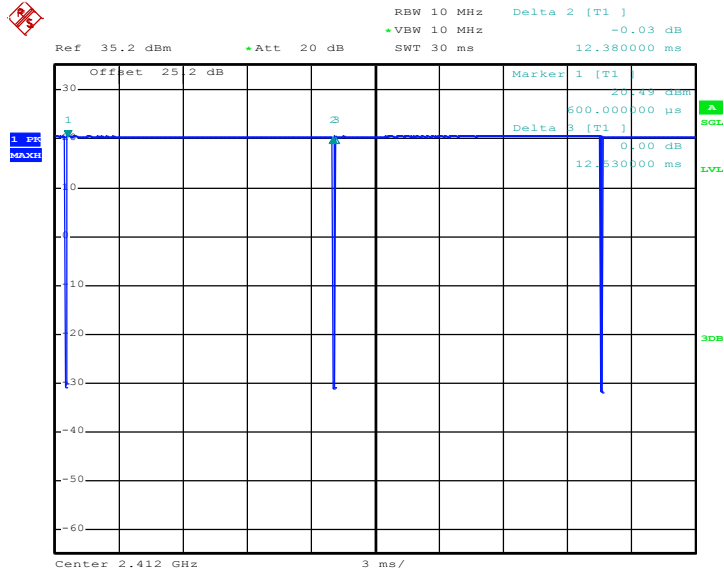

Date: 8.MAY.2020 13:54:51



802.11g

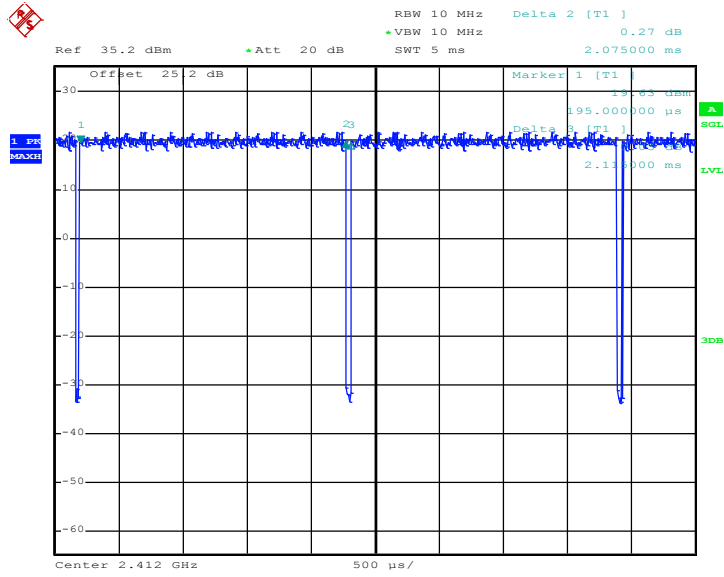

Date: 8.MAY.2020 14:00:51

802.11n HT20

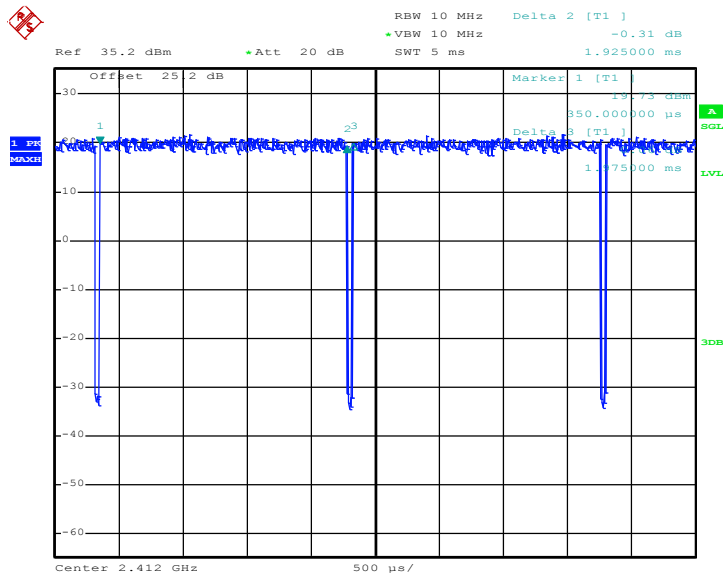

Date: 8.MAY.2020 14:10:09

—THE END—