



FCC RADIO TEST REPORT

FCC ID : A4RG025I
Equipment : Phone
Model Name : G025I, G025H
Applicant : Google LLC
1600 Amphitheatre Parkway,
Mountain View, California, 94043 USA
Standard : FCC Part 15 Subpart C §15.247

The product was received on May 08, 2020 and testing was started from Jun. 11, 2020 and completed on Jul. 02, 2020. We, SPORTON INTERNATIONAL INC., EMC & Wireless Communications Laboratory, would like to declare that the tested sample has been evaluated in accordance with the test procedures and has been in compliance with the applicable technical standards.

The test results in this variant report apply exclusively to the tested model / sample. Without written approval of SPORTON INTERNATIONAL INC. EMC & Wireless Communications Laboratory, the test report shall not be reproduced except in full.

Louis Wu

Approved by: Louis Wu

SPORTON INTERNATIONAL INC. EMC & Wireless Communications Laboratory
No. 52, Huaya 1st Rd., Guishan Dist., Taoyuan City, Taiwan (R.O.C.)



Table of Contents

| | |
|---|-----------|
| History of this test report..... | 3 |
| Summary of Test Result..... | 4 |
| 1 General Description..... | 5 |
| 1.1 Product Feature of Equipment Under Test..... | 5 |
| 1.2 Product Specification of Equipment Under Test..... | 5 |
| 1.3 Modification of EUT | 5 |
| 1.4 Testing Location | 6 |
| 1.5 Applicable Standards..... | 6 |
| 2 Test Configuration of Equipment Under Test..... | 7 |
| 2.1 Carrier Frequency Channel | 7 |
| 2.2 Test Mode..... | 8 |
| 2.3 Connection Diagram of Test System..... | 9 |
| 2.4 Support Unit used in test configuration and system | 9 |
| 2.5 EUT Operation Test Setup | 9 |
| 3 Test Result..... | 10 |
| 3.1 Output Power Measurement..... | 10 |
| 3.2 Radiated Band Edges and Spurious Emission Measurement | 11 |
| 3.3 Antenna Requirements | 16 |
| 4 List of Measuring Equipment | 17 |
| 5 Uncertainty of Evaluation..... | 18 |
| Appendix A. Conducted Test Results | |
| Appendix B. Radiated Spurious Emission | |
| Appendix C. Radiated Spurious Emission Plots | |
| Appendix D. Duty Cycle Plots | |



History of this test report

| Report No. | Version | Description | Issued Date |
|--------------|---------|---|---------------|
| FR022521-04B | 01 | Initial issue of report | Jul. 10, 2020 |
| FR022521-04B | 02 | Revising the remark description in summary. | Jul. 23, 2020 |
| | | | |
| | | | |
| | | | |
| | | | |
| | | | |
| | | | |
| | | | |
| | | | |
| | | | |
| | | | |
| | | | |
| | | | |
| | | | |
| | | | |
| | | | |
| | | | |



Summary of Test Result

| Report Clause | Ref Std. Clause | Test Items | Result (PASS/FAIL) | Remark |
|---------------|--------------------|--|--------------------|-------------------------------------|
| - | 15.247(a)(2) | 6dB Bandwidth | Not Required | - |
| - | 2.1049 | 99% Occupied Bandwidth | Not Required | - |
| 3.1 | 15.247(b)(3) | Output Power | Pass | - |
| - | 15.247(e) | Power Spectral Density | Not Required | - |
| - | 15.247(d) | Conducted Band Edges and Spurious Emission | Not Required | - |
| 3.2 | 15.247(d) | Radiated Band Edges and Spurious Emission | Pass | Under limit 7.53 dB at 2484.480 MHz |
| - | 15.207 | AC Conducted Emission | Not Required | - |
| 3.3 | 15.203 & 15.247(b) | Antenna Requirement | Pass | - |

Note:

1. Not required means after assessing, test items are not necessary to carry out.
2. This is a variant report which can be referred Product Equality Declaration. After spot-checking the tests, the parent test results were worse than variant test results, thus this test report was reuse parent test data, all the test cases were performed on original report which can be referred to Sporton Report Number FR022521-02B.

| |
|--|
| Declaration of Conformity: |
| The test results with all measurement uncertainty excluded are presented in accordance with the regulation limits or requirements declared by manufacturers. |
| Comments and Explanations: |
| The declared of product specification for EUT presented in the report are provided by the manufacturer, and the manufacturer takes all the responsibilities for the accuracy of product specification. |

Reviewed by: Wii Chang

Report Producer: Lucy Wu



1 General Description

1.1 Product Feature of Equipment Under Test

| Product Feature | |
|---------------------------------|--|
| Equipment | Phone |
| Model Name | G025I, G025H |
| FCC ID | A4RG025I |
| EUT supports Radios application | GSM/EGPRS/WCDMA/HSPA/LTE/NFC/GNSS/5G NR WLAN 11b/g/n HT20 WLAN 11a/n HT20/HT40 WLAN 11ac VHT20/VHT40/VHT80 Bluetooth BR/EDR/LE |

Remark: The above EUT's information was declared by manufacturer.

| EUT Information List | |
|----------------------|----------------------------|
| S/N | Performed Test Item |
| 04271FQCB00001 | RF Conducted Measurement |
| 04241FQCB00343 | Radiated Spurious Emission |

1.2 Product Specification of Equipment Under Test

| Standards-related Product Specification | |
|---|--|
| Tx/Rx Frequency Range | 2402 MHz ~ 2480 MHz |
| Number of Channels | 40 |
| Carrier Frequency of Each Channel | 40 Channel (37 hopping + 3 advertising channel) |
| Maximum Output Power to Antenna | Bluetooth LE (1Mbps) : 12.00 dBm (0.0158W) Bluetooth LE (2Mbps) : 12.00 dBm (0.0158W) |
| Antenna Type | Monopole Antenna type with gain 0.4 dBi |
| Type of Modulation | Bluetooth LE : GFSK |

1.3 Modification of EUT

No modifications are made to the EUT during all test items.



1.4 Testing Location

| | | |
|---------------------------|---|-----------|
| Test Site | SPORTON INTERNATIONAL INC. EMC & Wireless Communications Laboratory | |
| Test Site Location | No.52, Huaya 1st Rd., Guishan Dist., Taoyuan City, Taiwan (R.O.C.) TEL: +886-3-327-3456 FAX: +886-3-328-4978 | |
| Test Site No. | Sporton Site No. | |
| | TH05-HY | 03CH07-HY |

Note: The test site complies with ANSI C63.4 2014 requirement.

FCC designation No.: TW1190

1.5 Applicable Standards

According to the specifications of the manufacturer, the EUT must comply with the requirements of the following standards:

- ♦ FCC Part 15 Subpart C §15.247
- ♦ FCC KDB Publication No. 558074 D01 DTS Meas. Guidance v05r02
- ♦ FCC KDB 414788 D01 Radiated Test Site v01r01
- ♦ ANSI C63.10-2013

Remark:

1. All test items were verified and recorded according to the standards and without any deviation during the test.
2. The TAF code is not including all the FCC KDB listed without accreditation.
3. This EUT has also been tested and complied with the requirements of FCC Part 15, Subpart B, recorded in a separate test report.



2 Test Configuration of Equipment Under Test

2.1 Carrier Frequency Channel

| Frequency Band | Channel | Freq. (MHz) | Channel | Freq. (MHz) |
|-----------------|---------|-------------|---------|-------------|
| 2400-2483.5 MHz | 0 | 2402 | 21 | 2444 |
| | 1 | 2404 | 22 | 2446 |
| | 2 | 2406 | 23 | 2448 |
| | 3 | 2408 | 24 | 2450 |
| | 4 | 2410 | 25 | 2452 |
| | 5 | 2412 | 26 | 2454 |
| | 6 | 2414 | 27 | 2456 |
| | 7 | 2416 | 28 | 2458 |
| | 8 | 2418 | 29 | 2460 |
| | 9 | 2420 | 30 | 2462 |
| | 10 | 2422 | 31 | 2464 |
| | 11 | 2424 | 32 | 2466 |
| | 12 | 2426 | 33 | 2468 |
| | 13 | 2428 | 34 | 2470 |
| | 14 | 2430 | 35 | 2472 |
| | 15 | 2432 | 36 | 2474 |
| | 16 | 2434 | 37 | 2476 |
| | 17 | 2436 | 38 | 2478 |
| | 18 | 2438 | 39 | 2480 |
| | 19 | 2440 | - | - |
| 20 | 2442 | - | - | |



2.2 Test Mode

The EUT has been associated with peripherals and configuration operated in a manner tended to maximize its emission characteristics in a typical application. Frequency range investigated: radiation emission (9 kHz to the 10th harmonic of the highest fundamental frequency or to 40 GHz, whichever is lower). For radiated measurement, pre-scanned in three orthogonal panels, X, Y, Z. The worst cases (X plane with Notebook) were recorded in this report.

The following summary table is showing all test modes to demonstrate in compliance with the standard.

| Summary table of Test Cases | |
|--|--|
| Test Item | Data Rate / Modulation |
| | Bluetooth – LE / GFSK |
| Conducted Test Cases | Mode 1: Bluetooth Tx CH00_2402 MHz_1Mbps |
| | Mode 2: Bluetooth Tx CH19_2440 MHz_1Mbps |
| | Mode 3: Bluetooth Tx CH39_2480 MHz_1Mbps |
| | Mode 4: Bluetooth Tx CH00_2402 MHz_2Mbps |
| | Mode 5: Bluetooth Tx CH19_2440 MHz_2Mbps |
| | Mode 6: Bluetooth Tx CH39_2480 MHz_2Mbps |
| Radiated Test Cases | Mode 1: Bluetooth Tx CH39_2480 MHz_2Mbps |
| Remark: For Radiated Test Cases, the tests were performed with Adapter 1 and USB Cable 1. | |

2.3 Connection Diagram of Test System

<Bluetooth-LE Tx Mode>

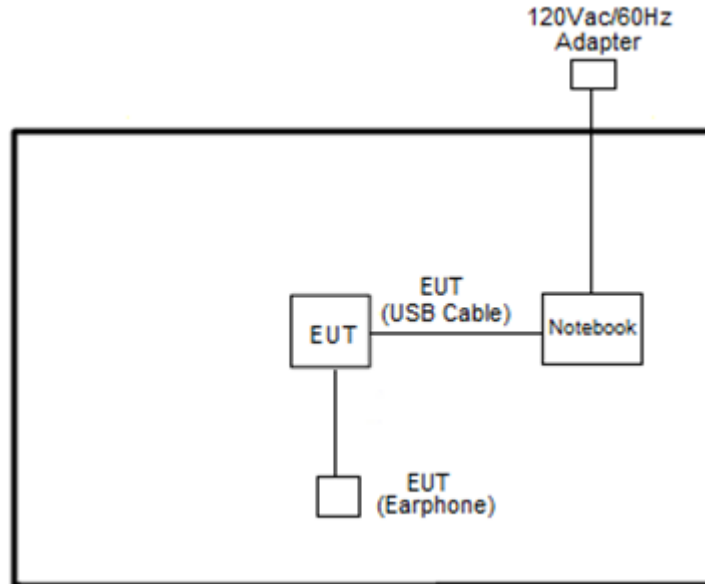

2.4 Support Unit used in test configuration and system

| Item | Equipment | Trade Name | Model Name | FCC ID | Data Cable | Power Cord |
|------|-----------|------------|------------|---------|------------|--|
| 1. | Notebook | DELL | P79G | FCC DoC | N/A | AC I/P: Unshielded, 1.2 m DC O/P: Shielded, 1.8 m |

2.5 EUT Operation Test Setup

The RF test items, utility "QRCT4_v 4.0.00158.0" was installed in Notebook which was programmed in order to make the EUT get into the engineering modes to provide channel selection, power level, data rate and the application type and for continuous transmitting signals.

3 Test Result

3.1 Output Power Measurement

3.1.1 Limit of Output Power

For systems using digital modulation in the 2400-2483.5MHz, the limit for output power is 30dBm. If transmitting antenna of directional gain greater than 6dBi is used, the peak output power from the intentional radiator shall be reduced below the above stated value by the amount in dB that the directional gain of the antenna exceeds 6 dBi. In case of point-to-point operation, the limit has to be reduced by 1dB for every 3dB that the directional gain of the antenna exceeds 6dBi.

3.1.2 Measuring Instruments

See list of measuring equipment of this test report.

3.1.3 Test Procedures

1. For Average Power, the testing follows ANSI C63.10 Section 11.9.2.3.2 Method AVGP-G
2. The RF output of EUT was connected to the power meter by RF cable and attenuator.
3. The path loss was compensated to the results for each measurement.
4. Set to the maximum power setting and enable the EUT transmit continuously.
5. Measure the conducted output power and record the results in the test report.

3.1.4 Test Setup

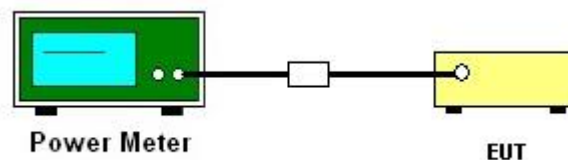

3.1.5 Test Result of Average Output Power

Please refer to Appendix A.



3.2 Radiated Band Edges and Spurious Emission Measurement

3.2.1 Limit of Radiated Band Edges and Spurious Emission

In any 100 kHz bandwidth outside the intentional radiator frequency band, all harmonics/spurious must be at least 20 dB below the highest emission level within the authorized band. If the output power of this device was measured by spectrum analyzer, the attenuation under this paragraph shall be 30 dB instead of 20 dB. In addition, radiated emissions which fall in the restricted bands must also comply with the limits as below.

| Frequency (MHz) | Field Strength (microvolts/meter) | Measurement Distance (meters) |
|-----------------|-----------------------------------|-------------------------------|
| 0.009 – 0.490 | 2400/F(kHz) | 300 |
| 0.490 – 1.705 | 24000/F(kHz) | 30 |
| 1.705 – 30.0 | 30 | 30 |
| 30 – 88 | 100 | 3 |
| 88 – 216 | 150 | 3 |
| 216 - 960 | 200 | 3 |
| Above 960 | 500 | 3 |

3.2.2 Measuring Instruments

See list of measuring equipment of this test report.



3.2.3 Test Procedures

1. The testing follows the ANSI C63.10 Section 11.12.1 Radiated emission measurements.
2. The EUT was arranged to its worst case and then tune the antenna tower (from 1 m to 4 m) and turntable (from 0 degree to 360 degrees) to find the maximum reading. A pre-amp and a high pass filter are used for the test in order to get better signal level.
3. The EUT was placed on a turntable with 0.8 meter for frequency below 1GHz and 1.5 meter for frequency above 1GHz respectively above ground.
4. The EUT was set 3 meters from the interference receiving antenna, which was mounted on the top of a variable height antenna tower.
5. Corrected Reading: Antenna Factor + Cable Loss + Read Level - Preamp Factor = Level
6. For testing below 1GHz, if the emission level of the EUT in peak mode was 3 dB lower than the limit specified, then peak values of EUT will be reported, otherwise, the emissions will be repeated one by one using the CISPR quasi-peak method and reported.
7. For testing above 1GHz, the emission level of the EUT in peak mode was 20dB lower than average limit (that means the emission level in average mode also complies with the limit in average mode), then peak values of EUT will be reported, otherwise, the emissions will be measured in average mode again and reported.
8. Use the following spectrum analyzer settings:
 - (1) Span shall wide enough to fully capture the emission being measured;
 - (2) Set RBW=100 kHz for $f < 1$ GHz; $VBW \geq RBW$; Sweep = auto; Detector function = peak; Trace = max hold;
 - (3) Set RBW = 1 MHz, VBW= 3MHz for $f \geq 1$ GHz for peak measurement.
For average measurement:
 - $VBW = 10$ Hz, when duty cycle is no less than 98 percent.
 - $VBW \geq 1/T$, when duty cycle is less than 98 percent where T is the minimum transmission duration over which the transmitter is on and is transmitting at its maximum power control level for the tested mode of operation.

3.2.4 Test Setup

For radiated emissions below 30MHz

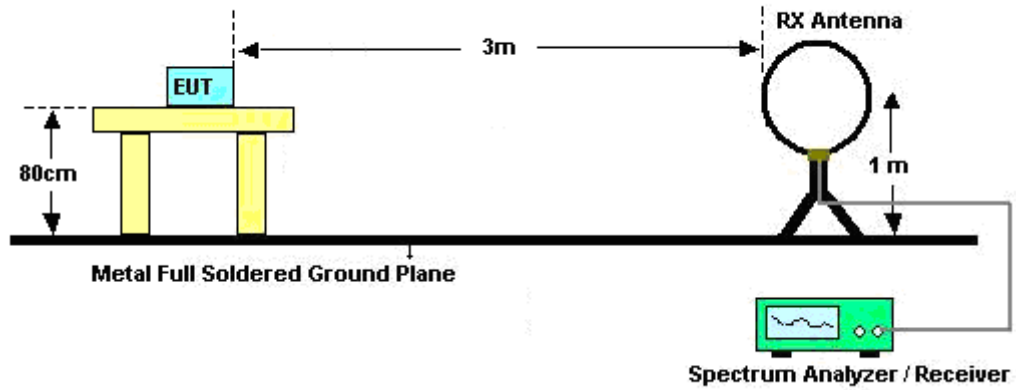

For radiated emissions from 30MHz to 1GHz

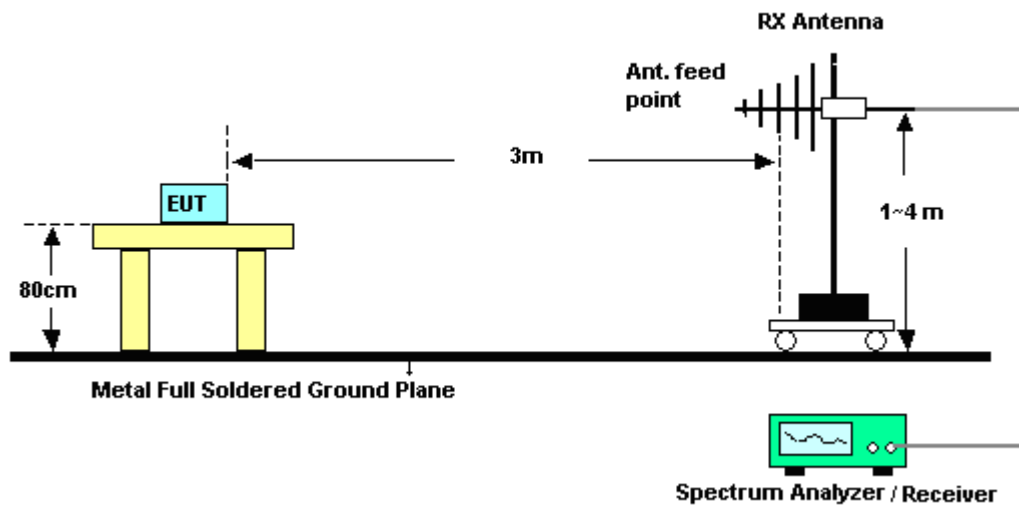

For radiated emissions above 1GHz

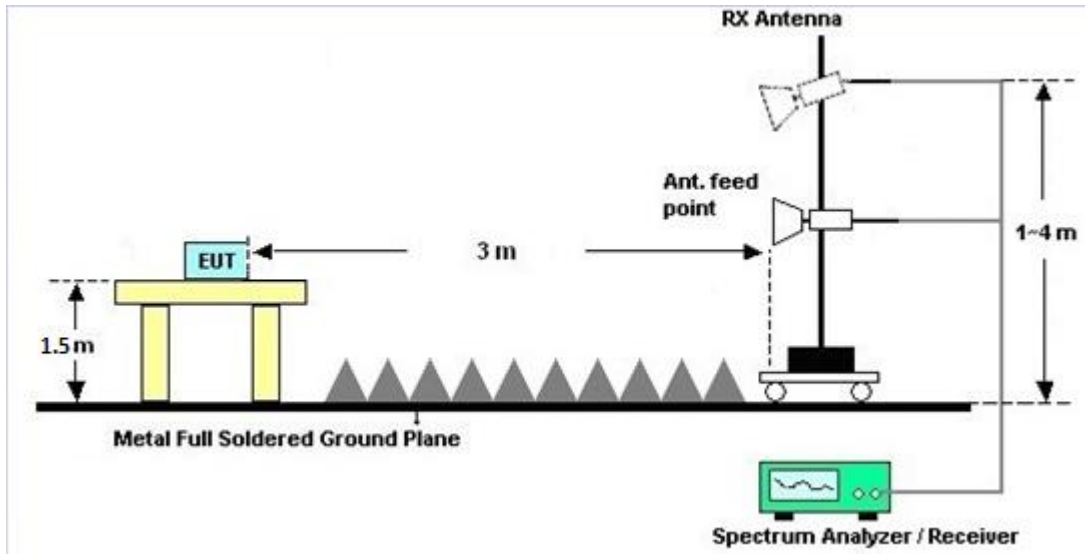

For radiated emissions above 18GHz

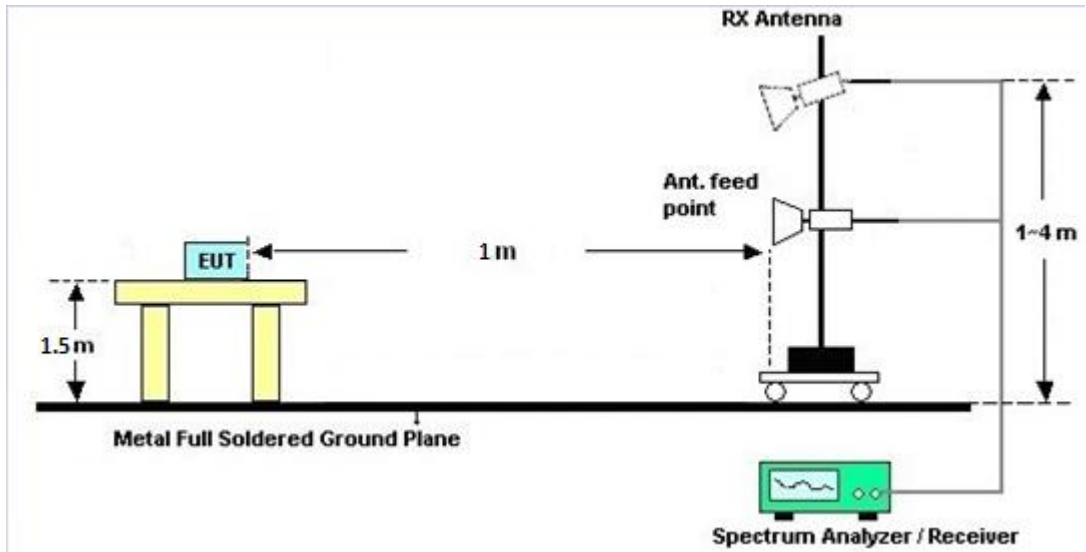



3.2.5 Test Results of Radiated Spurious Emissions (9 kHz ~ 30 MHz)

The low frequency, which started from 9 kHz to 30MHz, was pre-scanned and the result which was 20dB lower than the limit line was not reported.

There is a comparison data of both open-field test site and alternative test site - semi-Anechoic chamber according to 414788 D01 Radiated Test Site v01r01, and the result came out very similar.

3.2.6 Test Result of Radiated Spurious at Band Edges

Please refer to Appendix B and C.

3.2.7 Duty Cycle

Please refer to Appendix D.

3.2.8 Test Result of Radiated Spurious Emission (30MHz ~ 10th Harmonic)

Please refer to Appendix B and C.



3.3 Antenna Requirements

3.3.1 Standard Applicable

If directional gain of transmitting antennas is greater than 6dBi, the power shall be reduced by the same level in dB comparing to gain minus 6dBi. The use of a permanently attached antenna or of an antenna that uses a unique coupling to the intentional radiator shall be considered sufficient to comply with the rule.

3.3.2 Antenna Anti-Replacement Construction

An embedded-in antenna design is used.

3.3.3 Antenna Gain

The antenna peak gain of EUT is less than 6 dBi. Therefore, it is not necessary to reduce maximum peak output power limit.



4 List of Measuring Equipment

| Instrument | Manufacturer | Model No. | Serial No. | Characteristics | Calibration Date | Test Date | Due Date | Remark |
|---------------------------|-----------------|-----------------------------------|---------------------------------------|-----------------------|------------------|---------------------------------|---------------|-----------------------|
| Hygrometer | TECEPEL | DYM-303B | TP161250 | N/A | May 08, 2020 | Jun. 19, 2020 | May 07, 2021 | Conducted (TH05-HY) |
| Power Sensor | DARE | RPR3006W | 16I00054S NO10 | 10MHz~6GHz | Dec. 23, 2019 | Jun. 19, 2020 | Dec. 22, 2020 | Conducted (TH05-HY) |
| Spectrum Analyzer | Rohde & Schwarz | FSP40 | 100055 | 9kHz-40GHz | Aug. 14, 2019 | Jun. 19, 2020 | Aug. 13, 2020 | Conducted (TH05-HY) |
| Switch Box & RF Cable | Burgeon | ETF-058 | EC1300484 | N/A | Aug. 22, 2019 | Jun. 19, 2020 | Aug. 21, 2020 | Conducted (TH05-HY) |
| Power Supply | GW Instek | SPS-606 | GES842931 | NA | Aug. 19, 2019 | Jun. 19, 2020 | Aug. 18, 2020 | Conducted (TH05-HY) |
| Bilog Antenna | TESEQ | CBL 6111D & 00800N1D01 N-06 | 35419 & 03 | 30MHz~1GHz | Apr. 29, 2020 | Jun. 11, 2020~ Jul. 02, 2020 | Apr. 28, 2021 | Radiation (03CH07-HY) |
| Double Ridge Horn Antenna | ESCO | 3117 | 00075962 | 1GHz ~ 18GHz | Dec. 06, 2019 | Jun. 11, 2020~ Jul. 02, 2020 | Dec. 05, 2020 | Radiation (03CH07-HY) |
| EMI Test Receiver | Agilent | N9038A(MXE) | MY5329005 3 | 20Hz~26.5GHz | Jan. 18, 2020 | Jun. 11, 2020~ Jul. 02, 2020 | Jan. 17, 2021 | Radiation (03CH07-HY) |
| Loop Antenna | Rohde & Schwarz | HFH2-Z2 | 100315 | 9 kHz~30 MHz | Dec. 26, 2019 | Jun. 11, 2020~ Jul. 02, 2020 | Dec. 25, 2020 | Radiation (03CH07-HY) |
| Preamplifier | MITEQ | AMF-7D-001 01800-30-10 P | 1590075 | 1GHz~18GHz | Apr. 23, 2020 | Jun. 11, 2020~ Jul. 02, 2020 | Apr. 22, 2021 | Radiation (03CH07-HY) |
| Preamplifier | COM-POWER | PA-103A | 161241 | 10MHz~1GHz | May 19, 2020 | Jun. 11, 2020~ Jul. 02, 2020 | May 18, 2021 | Radiation (03CH07-HY) |
| Preamplifier | Agilent | 8449B | 3008A0236 2 | 1GHz~26.5GHz | Nov. 01, 2019 | Jun. 11, 2020~ Jul. 02, 2020 | Oct. 31, 2020 | Radiation (03CH07-HY) |
| RF Cable | HUBER + SUHNER | SUCOFLEX 102 | MY2858/2,8 01606/2 | 18GHz~40GHz | Feb. 25, 2020 | Jun. 11, 2020~ Jul. 02, 2020 | Feb. 24, 2021 | Radiation (03CH07-HY) |
| RF Cable | HUBER + SUHNER | SUCOFLEX 104 | MY24971/4, MY28655/4 | 9kHz~30MHz | Feb. 25, 2020 | Jun. 11, 2020~ Jul. 02, 2020 | Feb. 24, 2021 | Radiation (03CH07-HY) |
| RF Cable | HUBER + SUHNER | SUCOFLEX 104 | MY28655/4, MY24971/4, MY15682/4 | 30MHz~1GHz | Feb. 25, 2020 | Jun. 11, 2020~ Jul. 02, 2020 | Feb. 24, 2021 | Radiation (03CH07-HY) |
| RF Cable | HUBER + SUHNER | SUCOFLEX 104 | MY28655/4, MY24971/4, MY15682/4 | 1GHz~18GHz | Feb. 25, 2020 | Jun. 11, 2020~ Jul. 02, 2020 | Feb. 24, 2021 | Radiation (03CH07-HY) |
| Controller | ChainTek | Chaintek 3000 | N/A | Control Turn table | N/A | Jun. 11, 2020~ Jul. 02, 2020 | N/A | Radiation (03CH07-HY) |
| Controller | Max-Full | MF7802 | MF7802083 68 | Control Ant Mast | N/A | Jun. 11, 2020~ Jul. 02, 2020 | N/A | Radiation (03CH07-HY) |
| Antenna Mast | Max-Full | MFA520BS | N/A | 1m~4m | N/A | Jun. 11, 2020~ Jul. 02, 2020 | N/A | Radiation (03CH07-HY) |
| Turn Table | ChainTek | Chaintek 3000 | N/A | 0~360 Degree | N/A | Jun. 11, 2020~ Jul. 02, 2020 | N/A | Radiation (03CH07-HY) |
| USB Data Logger | TECEPEL | TR-32 | HE17XB249 5 | N/A | N/A | Jun. 11, 2020~ Jul. 02, 2020 | N/A | Radiation (03CH07-HY) |
| Spectrum Analyzer | Keysight | N9010A | MY5420048 6 | 10Hz~44GHz | Oct. 28, 2019 | Jun. 11, 2020~ Jul. 02, 2020 | Oct. 27, 2020 | Radiation (03CH07-HY) |
| SHF-EHF Horn Antenna | SCHWARZBE CK | BBHA 9170 | BBHA91705 84 | 18GHz~40GHz | Dec. 10, 2019 | Jun. 11, 2020~ Jul. 02, 2020 | Dec. 09, 2020 | Radiation (03CH07-HY) |
| Software | Audix | E3 6.2009-8-24 | N/A | N/A | N/A | Jun. 11, 2020~ Jul. 02, 2020 | N/A | Radiation (03CH07-HY) |
| Preamplifier | EMEC | EM18G40G | 060715 | 18GHz~40GHz | Dec. 13, 2019 | Jun. 11, 2020~ Jul. 02, 2020 | Dec. 12, 2020 | Radiation (03CH07-HY) |



5 Uncertainty of Evaluation

Uncertainty of Radiated Emission Measurement (30 MHz ~ 1000 MHz)

| | |
|---|-----|
| Measuring Uncertainty for a Level of Confidence of 95% ($U = 2Uc(y)$) | 4.6 |
|---|-----|

Uncertainty of Radiated Emission Measurement (1000 MHz ~ 18000 MHz)

| | |
|---|-----|
| Measuring Uncertainty for a Level of Confidence of 95% ($U = 2Uc(y)$) | 5.2 |
|---|-----|

Uncertainty of Radiated Emission Measurement (18000 MHz ~ 40000 MHz)

| | |
|---|-----|
| Measuring Uncertainty for a Level of Confidence of 95% ($U = 2Uc(y)$) | 5.3 |
|---|-----|

Appendix A. Test Result of Conducted Test Items

| | | | | |
|----------------|------------|--------------------|-----------|----|
| Test Engineer: | Kathy Chen | Temperature: | 20.1~23.5 | °C |
| Test Date: | 2020/06/19 | Relative Humidity: | 45.7~58.8 | % |

TEST RESULTS DATA**Average Power Table**

| Mod. | Data Rate | N _{TX} | CH. | Freq. (MHz) | Average Conducted Power (dBm) |
|------|-----------|-----------------|-----|-------------|-------------------------------|
| BLE | 1Mbps | 1 | 0 | 2402 | 11.80 |
| BLE | 1Mbps | 1 | 19 | 2440 | 12.00 |
| BLE | 1Mbps | 1 | 39 | 2480 | 11.40 |

TEST RESULTS DATA
Average Power Table

| Mod. | Data Rate | NTX | CH. | Freq. (MHz) | Average Conducted Power (dBm) |
|------|-----------|-----|-----|-------------|-------------------------------|
| BLE | 2Mbps | 1 | 0 | 2402 | 11.80 |
| BLE | 2Mbps | 1 | 19 | 2440 | 12.00 |
| BLE | 2Mbps | 1 | 39 | 2480 | 11.40 |



Appendix B. Radiated Spurious Emission

| | | | |
|-----------------|--------------------------------|---------------------|---------|
| Test Engineer : | Jesse Wang, Stan Hsieh, Ken Wu | Temperature : | 23~26°C |
| | | Relative Humidity : | 45~52% |

<2Mbps>

2.4GHz 2400~2483.5MHz

BLE (Band Edge @ 3m)

| BLE | Note | Frequency (MHz) | Level (dBμV/m) | Over Limit (dB) | Limit Line (dBμV/m) | Read Level (dBμV) | Antenna Factor (dB/m) | Path Loss (dB) | Preamp Factor (dB) | Ant Pos (cm) | Table Pos (deg) | Peak Avg. (P/A) | Pol. (H/V) |
|-------------------------|---|----------------------|---------------------|-------------------------|-----------------------------|---------------------------|-------------------------------|------------------------|----------------------------|----------------------|-------------------------|-------------------------|-----------------|
| BLE CH 39 2480MHz | * | 2480 | 105.71 | - | - | 90.81 | 32.07 | 18.12 | 35.29 | 100 | 197 | P | H |
| | * | 2480 | 103.78 | - | - | 88.88 | 32.07 | 18.12 | 35.29 | 100 | 197 | A | H |
| | | 2483.96 | 56.98 | -17.02 | 74 | 42.08 | 32.07 | 18.12 | 35.29 | 100 | 197 | P | H |
| | | 2483.68 | 46.36 | -7.64 | 54 | 31.46 | 32.07 | 18.12 | 35.29 | 100 | 197 | A | H |
| | | | | | | | | | | | | | H |
| | | | | | | | | | | | | | H |
| | * | 2480 | 102.69 | - | - | 87.79 | 32.07 | 18.12 | 35.29 | 394 | 78 | P | V |
| | * | 2480 | 101.57 | - | - | 86.67 | 32.07 | 18.12 | 35.29 | 394 | 78 | A | V |
| | | 2483.52 | 57.79 | -16.21 | 74 | 42.89 | 32.07 | 18.12 | 35.29 | 394 | 78 | P | V |
| | | 2484.48 | 46.47 | -7.53 | 54 | 31.57 | 32.07 | 18.12 | 35.29 | 394 | 78 | A | V |
| | | | | | | | | | | | | | V |
| | | | | | | | | | | | | | V |
| Remark | 1. No other spurious found. 2. All results are PASS against Peak and Average limit line. | | | | | | | | | | | | |



2.4GHz 2400~2483.5MHz
BLE (Harmonic @ 3m)

| BLE | Note | Frequency (MHz) | Level (dBµV/m) | Over Limit (dB) | Limit Line (dBµV/m) | Read Level (dBµV) | Antenna Factor (dB/m) | Path Loss (dB) | Preamp Factor (dB) | Ant Pos (cm) | Table Pos (deg) | Peak Avg. (P/A) | Pol. (H/V) |
|-------------------------|---|----------------------|---------------------|-------------------------|-----------------------------|---------------------------|-------------------------------|------------------------|----------------------------|----------------------|-------------------------|-------------------------|-----------------|
| BLE CH 39 2480MHz | | 4960 | 39.98 | -34.02 | 74 | 52.12 | 34.23 | 12.18 | 58.55 | 100 | 0 | P | H |
| | | 7440 | 41.9 | -32.1 | 74 | 49.31 | 35.5 | 14.68 | 57.59 | 100 | 0 | P | H |
| | | | | | | | | | | | | | H |
| | | | | | | | | | | | | | H |
| | | 4960 | 40.21 | -33.79 | 74 | 52.35 | 34.23 | 12.18 | 58.55 | 100 | 0 | P | V |
| | | 7440 | 41.44 | -32.56 | 74 | 48.85 | 35.5 | 14.68 | 57.59 | 100 | 0 | P | V |
| | | | | | | | | | | | | | V |
| | | | | | | | | | | | | | V |
| Remark | 1. No other spurious found. 2. All results are PASS against Peak and Average limit line. | | | | | | | | | | | | |



Emission above 18GHz

2.4GHz BLE (SHF)

| BLE | Note | Frequency | Level | Over | Limit | Read | Antenna | Path | Preamp | Ant | Table | Peak | Pol. | |
|----------------------|---------------|--|------------------|--------|------------------|----------------|----------|--------|--------|--------|---------|---------|---------|---|
| | | | | Limit | Line | Level | Factor | Loss | Factor | Pos | Pos | Avg. | | |
| | | (MHz) | (dB μ V/m) | (dB) | (dB μ V/m) | (dB μ V) | (dB/m) | (dB) | (dB) | (cm) | (deg) | (P/A) | (H/V) | |
| 2.4GHz BLE SHF | | 24538 | 36.59 | -37.41 | 74 | 43.44 | 39.88 | 6.77 | 53.5 | 150 | 0 | P | H | |
| | | | | | | | | | | | | | H | |
| | | | | | | | | | | | | | H | |
| | | | | | | | | | | | | | H | |
| | | | | | | | | | | | | | H | |
| | | | | | | | | | | | | | H | |
| | | | 23894 | 38.07 | -35.93 | 74 | 45.28 | 39.61 | 6.48 | 53.3 | 150 | 0 | P | V |
| | | | | | | | | | | | | | | V |
| | | | | | | | | | | | | | | V |
| | | | | | | | | | | | | | | V |
| | | | | | | | | | | | | | | V |
| | Remark | 1. No other spurious found. 2. All results are PASS against limit line. | | | | | | | | | | | | |



Emission below 1GHz

2.4GHz BLE (LF)

| BLE | Note | Frequency | Level | Over | Limit | Read | Antenna | Path | Preamp | Ant | Table | Peak | Pol. | |
|---------------------|--|-----------|------------|--------|------------|----------|----------|--------|--------|--------|---------|---------|---------|---|
| | | (MHz) | (dBμV/m) | (dB) | (dBμV/m) | (dBμV) | (dB/m) | (dB) | (dB) | (cm) | (deg) | (P/A) | (H/V) | |
| 2.4GHz BLE LF | | 30 | 22.52 | -17.48 | 40 | 27.27 | 24.32 | 0.94 | 30.01 | - | - | P | H | |
| | | 107.49 | 23.26 | -20.24 | 43.5 | 34.56 | 16.82 | 1.85 | 29.97 | - | - | P | H | |
| | | 177.96 | 30.2 | -13.3 | 43.5 | 42.74 | 15 | 2.4 | 29.94 | - | - | P | H | |
| | | 872.6 | 32.91 | -13.09 | 46 | 27.89 | 28.85 | 5.29 | 29.12 | - | - | P | H | |
| | | 918.8 | 33.85 | -12.15 | 46 | 28.21 | 29.04 | 5.48 | 28.88 | - | - | P | H | |
| | | 953.8 | 33.95 | -12.05 | 46 | 26.62 | 30.42 | 5.59 | 28.68 | 100 | 0 | P | H | |
| | | | | | | | | | | | | | H | |
| | | | | | | | | | | | | | H | |
| | | | | | | | | | | | | | H | |
| | | | | | | | | | | | | | H | |
| | | | | | | | | | | | | | H | |
| | | | | | | | | | | | | | H | |
| | | | 30.27 | 32.07 | -7.93 | 40 | 36.82 | 24.32 | 0.94 | 30.01 | 100 | 0 | P | V |
| | | | 45.39 | 27.14 | -12.86 | 40 | 39.69 | 16.29 | 1.15 | 29.99 | - | - | P | V |
| | | | 179.85 | 23.41 | -20.09 | 43.5 | 36 | 14.94 | 2.41 | 29.94 | - | - | P | V |
| | | | 853.7 | 32.61 | -13.39 | 46 | 27.8 | 28.81 | 5.2 | 29.2 | - | - | P | V |
| | | | 921.6 | 33.47 | -12.53 | 46 | 27.73 | 29.11 | 5.49 | 28.86 | - | - | P | V |
| | | | 948.2 | 34.62 | -11.38 | 46 | 27.64 | 30.12 | 5.57 | 28.71 | - | - | P | V |
| | | | | | | | | | | | | | | V |
| | | | | | | | | | | | | | | V |
| | | | | | | | | | | | | | V | |
| | | | | | | | | | | | | | V | |
| | | | | | | | | | | | | | V | |
| | | | | | | | | | | | | | V | |
| Remark | 1. No other spurious found. 2. All results are PASS against limit line. | | | | | | | | | | | | | |



Note symbol

| | |
|-----|--|
| * | Fundamental Frequency which can be ignored. However, the level of any unwanted emissions shall not exceed the level of the fundamental frequency. |
| ! | Test result is over limit line. |
| P/A | Peak or Average |
| H/V | Horizontal or Vertical |



A calculation example for radiated spurious emission is shown as below:

| BLE | Note | Frequency | Level | Over | Limit | Read | Antenna | Path | Preamp | Ant | Table | Peak | Pol. |
|-------------------------|------|-----------|------------|--------|------------|----------|----------|--------|--------|--------|---------|---------|---------|
| | | (MHz) | (dBμV/m) | (dB) | (dBμV/m) | (dBμV) | (dB/m) | (dB) | (dB) | (cm) | (deg) | (P/A) | (H/V) |
| BLE CH 00 2402MHz | | 2390 | 55.45 | -18.55 | 74 | 54.51 | 32.22 | 4.58 | 35.86 | 103 | 308 | P | H |
| | | 2390 | 43.54 | -10.46 | 54 | 42.6 | 32.22 | 4.58 | 35.86 | 103 | 308 | A | H |

1. Path Loss(dB) = Cable loss(dB) + Filter loss(dB) + Attenuator loss(dB)
2. Level(dBμV/m) =
Antenna Factor(dB/m) + Path Loss(dB) + Read Level(dBμV) - Preamp Factor(dB)
3. Over Limit(dB) = Level(dBμV/m) – Limit Line(dBμV/m)

For Peak Limit @ 2390MHz:

1. Level(dBμV/m)
= Antenna Factor(dB/m) + Path Loss(dB) + Read Level(dBμV) - Preamp Factor(dB)
= 32.22(dB/m) + 4.58(dB) + 54.51(dBμV) – 35.86 (dB)
= 55.45 (dBμV/m)
2. Over Limit(dB)
= Level(dBμV/m) – Limit Line(dBμV/m)
= 55.45(dBμV/m) – 74(dBμV/m)
= -18.55(dB)

For Average Limit @ 2390MHz:

1. Level(dBμV/m)
= Antenna Factor(dB/m) + Path Loss(dB) + Read Level(dBμV) - Preamp Factor(dB)
= 32.22(dB/m) + 4.58(dB) + 42.6(dBμV) – 35.86 (dB)
= 43.54 (dBμV/m)
2. Over Limit(dB)
= Level(dBμV/m) – Limit Line(dBμV/m)
= 43.54(dBμV/m) – 54(dBμV/m)
= -10.46(dB)

Both peak and average measured complies with the limit line, so test result is “PASS”.



Appendix C. Radiated Spurious Emission Plots

| | | | |
|-----------------|--------------------------------|---------------------|---------|
| Test Engineer : | Jesse Wang, Stan Hsieh, Ken Wu | Temperature : | 23~26°C |
| | | Relative Humidity : | 45~52% |

Note symbol

| | |
|----|-----------------------|
| -L | Low channel location |
| -R | High channel location |



<2Mbps>

2.4GHz 2400~2483.5MHz

BLE (Band Edge @ 3m)

| BLE | 2.4GHz 2400~2483.5MHz Band Edge @ 3m | |
|------------------|--|---|
| BLE CH39 2480MHz | | |
| Horizontal | | Fundamental |
| Peak | <p>Date: 2020-06-19</p> <p>Site : 03CH07-HY Condition : PEAK_BE_74 3m HF_ANT_00075962 HORIZONTAL Detector : Peak Project : 022521-04 Mode : 11</p> | <p>Date: 2020-06-19</p> <p>Site : 03CH07-HY Condition : PEAK_74 3m HF_ANT_00075962 HORIZONTAL Detector : Peak Project : 022521-04 Mode : 11</p> |
| Avg. | <p>Date: 2020-06-19</p> <p>Site : 03CH07-HY Condition : AVG_BE_54 3m HF_ANT_00075962 HORIZONTAL Detector : Peak Project : 022521-04 Mode : 11</p> | <p>Date: 2020-06-19</p> <p>Site : 03CH07-HY Condition : AVG_54 3m HF_ANT_00075962 HORIZONTAL Detector : Peak Project : 022521-04 Mode : 11</p> |

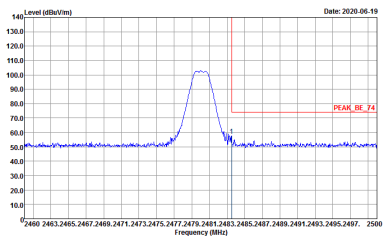
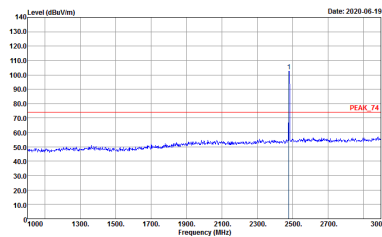
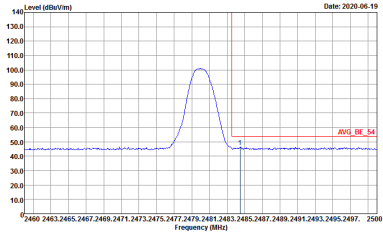
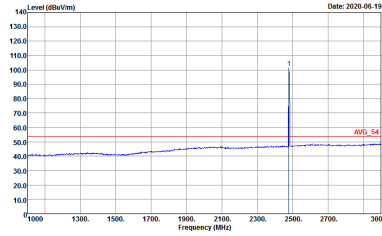

| BLE | 2.4GHz 2400~2483.5MHz Band Edge @ 3m | |
|------------------|---|---|
| BLE CH39 2480MHz | | |
| Vertical | | Fundamental |
| Peak |  <p>Site : 03CH07-HY Condition : PEAK_BE_74 3m HF_ANT_00075962 VERTICAL Detector : Peak Project : 022521-04 Mode : 11</p> |  <p>Site : 03CH07-HY Condition : PEAK_74 3m HF_ANT_00075962 VERTICAL Detector : Peak Project : 022521-04 Mode : 11</p> |
| Avg. |  <p>Site : 03CH07-HY Condition : AVG_BE_54 3m HF_ANT_00075962 VERTICAL Detector : Peak Project : 022521-04 Mode : 11</p> |  <p>Site : 03CH07-HY Condition : AVG_54 3m HF_ANT_00075962 VERTICAL Detector : Peak Project : 022521-04 Mode : 11</p> |



2.4GHz 2400~2483.5MHz

BLE (Harmonic @ 3m)

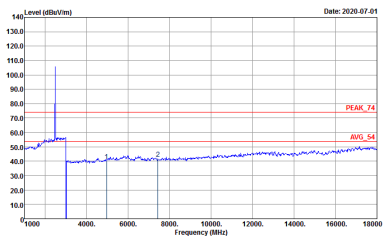
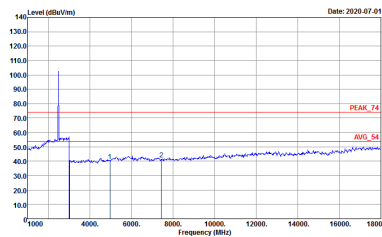
| | | |
|--------------------------------|---|--|
| BLE | 2.4GHz 2400~2483.5MHz Harmonic @ 3m | |
| | BLE CH39 2480MHz | |
| | Horizontal | Vertical |
| Peak Avg. |  <p>Site : 09CH07-HY Condition : PEAK_74 3m HF_ANT_00075962 HORIZONTAL Detector : Peak Project : 022521-04 Mode : 11</p> |  <p>Site : 09CH07-HY Condition : PEAK_74 3m HF_ANT_00075962 VERTICAL Detector : Peak Project : 022521-04 Mode : 11</p> |



Emission above 18GHz

2.4GHz BLE (SHF)

| BLE | 2.4GHz 2400~2483.5MHz | |
|----------------------------|---|---|
| | BLE SHF | |
| | Horizontal | Vertical |
| Peak Avg. | <p>Site : 03CH07-HY Condition : PEAK_74 2m SHF-EHF_9170584 HORIZONTAL Detector : Peak Project : 022521-04 Mode : 26</p> | <p>Site : 03CH07-HY Condition : PEAK_74 2m SHF-EHF_9170584 VERTICAL Detector : Peak Project : 022521-04 Mode : 26</p> |



Emission below 1GHz

2.4GHz BLE (LF)

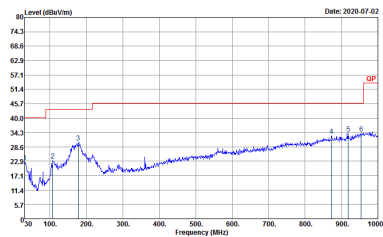
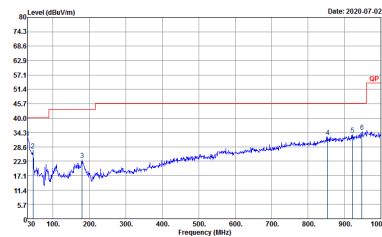
| | | |
|----------------------|--|---|
| BLE | 2.4GHz 2400~2483.5MHz | |
| | BLE LF | |
| | Horizontal | Vertical |
| QP / Peak |  <p>Site : 03CH07-HY Condition : QP 3m LF-ANT-35419(G) HORIZONTAL Detector : Peak Project : 022521-04 Mode : 12</p> |  <p>Site : 03CH07-HY Condition : QP 3m LF-ANT-35419(G) VERTICAL Detector : Peak Project : 022521-04 Mode : 12</p> |



Appendix D. Duty Cycle Plots

| Band | Duty Cycle(%) | T(us) | 1/T(kHz) | VBW Setting | Duty Factor(dB) |
|-------------------------|---------------|-------|----------|-------------|-----------------|
| Bluetooth –LE for 2Mbps | 34.08 | 214 | 4.67 | 10kHz | 4.68 |

Bluetooth – LE for 2Mbps

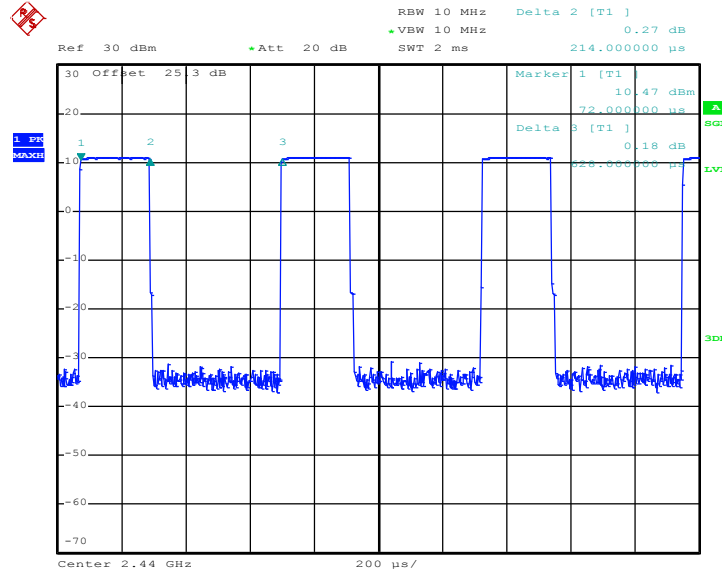

Date: 19.JUN.2020 11:56:31

—THE END—