



FCC RADIO TEST REPORT

FCC ID : A4RG020J
Equipment : Phone
Model Name : G020J
Applicant : Google LLC
1600 Amphitheatre Parkway,
Mountain View, California, 94043 USA
Standard : FCC Part 15 Subpart C §15.247

The product was received on Nov. 07, 2018 and testing was started from Apr. 10, 2019 and completed on Jun. 22, 2019. We, SPORTON INTERNATIONAL INC., EMC & Wireless Communications Laboratory, would like to declare that the tested sample has been evaluated in accordance with the test procedures and has been in compliance with the applicable technical standards.

The report must not be used by the client to claim product certification, approval, or endorsement by TAF or any agency of government.

The test results in this report apply exclusively to the tested model / sample. Without written approval of SPORTON INTERNATIONAL INC. EMC & Wireless Communications Laboratory, the test report shall not be reproduced except in full.

Approved by: Jones Tsai

SPORTON INTERNATIONAL INC. EMC & Wireless Communications Laboratory
No. 52, Huaya 1st Rd., Guishan Dist., Taoyuan City, Taiwan (R.O.C.)



Table of Contents

History of this test report.....	3
Summary of Test Result.....	4
1 General Description	5
1.1 Product Feature of Equipment Under Test.....	5
1.2 Product Specification of Equipment Under Test.....	6
1.3 Modification of EUT	6
1.4 Testing Location	7
1.5 Applicable Standards.....	7
2 Test Configuration of Equipment Under Test	8
2.1 Carrier Frequency and Channel	8
2.2 Test Mode.....	9
2.3 Connection Diagram of Test System.....	10
2.4 Support Unit used in test configuration and system	12
2.5 EUT Operation Test Setup	12
2.6 Measurement Results Explanation Example.....	12
3 Test Result	13
3.1 6dB and 99% Bandwidth Measurement	13
3.2 Output Power Measurement.....	15
3.3 Power Spectral Density Measurement	16
3.4 Conducted Band Edges and Spurious Emission Measurement	18
3.5 Radiated Band Edges and Spurious Emission Measurement	49
3.6 AC Conducted Emission Measurement.....	53
3.7 Antenna Requirements	55
4 List of Measuring Equipment.....	56
5 Uncertainty of Evaluation	58
Appendix A. Conducted Test Results	
Appendix B. AC Conducted Emission Test Result	
Appendix C. Radiated Spurious Emission	
Appendix D. Radiated Spurious Emission Plots	
Appendix E. Duty Cycle Plots	



History of this test report

Report No.	Version	Description	Issued Date
FR8N0620-05C	01	Initial issue of report	Jun. 27, 2019
FR8N0620-05C	02	Revise the antenna numbers in the report	Jul. 09, 2019



Summary of Test Result

Report Clause	Ref Std. Clause	Test Items	Result (PASS/FAIL)	Remark
3.1	15.247(a)(2)	6dB Bandwidth	Pass	-
3.1	2.1049	99% Occupied Bandwidth	Reporting only	-
3.2	15.247(b)	Power Output Measurement	Pass	-
3.3	15.247(e)	Power Spectral Density	Pass	-
3.4	15.247(d)	Conducted Band Edges	Pass	-
		Conducted Spurious Emission	Pass	-
3.5	15.247(d)	Radiated Band Edges and Radiated Spurious Emission	Pass	Under limit 1.52 dB at 7386.000 MHz
3.6	15.207	AC Conducted Emission	Pass	Under limit 10.28 dB at 0.157 MHz
3.7	15.203 & 15.247(b)	Antenna Requirement	Pass	-

Declaration of Conformity:

The test results with all measurement uncertainty excluded are presented in accordance with the regulation limits or requirements declared by manufacturers.

Comments and Explanations:

The declared of product specification for EUT presented in the report are provided by the manufacturer, and the manufacturer takes all the responsibilities for the accuracy of product specification.

Reviewed by: Wii Chang

Report Producer: Ann Lee



1 General Description

1.1 Product Feature of Equipment Under Test

Product Feature	
Equipment	Phone
Model Name	G020J
FCC ID	A4RG020J
EUT supports Radios application	CDMA/EV-DO/GSM/EGPRS/WCDMA/HSPA/LTE/NFC/GNSS/WPC WLAN 11b/g/n HT20 WLAN 11a/n HT20/HT40 WLAN 11ac VHT20/VHT40/VHT80 Bluetooth BR/EDR/LE 60 GHz Low Power Transmitter
EUT Stage	Identical Prototype

Remark: The above EUT's information was declared by manufacturer.

EUT Information List	
No.	S/N
#1	94NBA009QB
#2	958BA00AJC
#3	957BA00AGL

1.2 Product Specification of Equipment Under Test

Standards-related Product Specification										
Tx/Rx Channel Frequency Range	2412 MHz ~ 2472 MHz									
Maximum (Average) Output Power to antenna	<p><Ant. 2> 802.11b : 22.60 dBm (0.1820 W) 802.11g : 21.40 dBm (0.1380 W) 802.11n HT20 : 21.10 dBm (0.1288 W) 802.11 ac VHT20 : 21.00 dBm (0.1259 W)</p> <p><Ant. 4> 802.11b : 22.60 dBm (0.1820 W) 802.11g : 21.30 dBm (0.1349 W) 802.11n HT20 : 20.90 dBm (0.1230 W) 802.11 ac VHT20 : 20.80 dBm (0.1202 W)</p> <p>MIMO <Ant. 2+4> 802.11b : 25.86 dBm (0.3855 W) 802.11g : 24.47 dBm (0.2799 W) 802.11n HT20 : 24.17 dBm (0.2612 W) 802.11 ac VHT20 : 24.12 dBm (0.2582 W)</p>									
99% Occupied Bandwidth	<p><MIMO Ant. 2> 802.11b : 14.30MHz 802.11g : 17.50MHz 802.11n HT20 : 18.25MHz</p> <p><MIMO Ant. 4> 802.11b : 14.80MHz 802.11g : 17.15MHz 802.11n HT20 : 18.35MHz</p>									
Antenna Type / Gain	<p><Ant. 2>IFA Antenna type with gain -0.50 dBi <Ant. 4>IFA Antenna type with gain -2.90 dBi</p>									
Type of Modulation	802.11b : DSSS (DBPSK / DQPSK / CCK) 802.11g/n : OFDM (BPSK / QPSK / 16QAM / 64QAM) 802.11ac : OFDM (BPSK / QPSK / 16QAM / 64QAM / 256QAM)									
Antenna Function for Transmitter	<table border="1"> <thead> <tr> <th></th> <th>Ant. 2</th> <th>Ant. 4</th> </tr> </thead> <tbody> <tr> <td>802.11 b/g/n/ac</td> <td>V</td> <td>V</td> </tr> <tr> <td>802.11 b/g/n/ac MIMO</td> <td>V</td> <td>V</td> </tr> </tbody> </table>		Ant. 2	Ant. 4	802.11 b/g/n/ac	V	V	802.11 b/g/n/ac MIMO	V	V
	Ant. 2	Ant. 4								
802.11 b/g/n/ac	V	V								
802.11 b/g/n/ac MIMO	V	V								

Note: MIMO Ant. 2+4 is a calculated result from sum of the power MIMO Ant. 2 and MIMO Ant. 4.

1.3 Modification of EUT

No modifications are made to the EUT during all test items.



1.4 Testing Location

Test Site	SPORTON INTERNATIONAL INC. EMC & Wireless Communications Laboratory	
Test Site Location	No.52, Huaya 1st Rd., Guishan Dist., Taoyuan City, Taiwan (R.O.C.) TEL: +886-3-327-3456 FAX: +886-3-328-4978	
Test Site No.	Sporton Site No.	
	TH05-HY	CO05-HY

Note: The test site complies with ANSI C63.4 2014 requirement.

Test Site	SPORTON INTERNATIONAL INC. EMC & Wireless Communications Laboratory	
Test Site Location	No.58, Aly. 75, Ln. 564, Wenhua 3rd, Rd., Guishan Dist., Taoyuan City, Taiwan (R.O.C.) TEL: +886-3-327-0868 FAX: +886-3-327-0855	
Test Site No.	Sporton Site No.	
	03CH13-HY	

Note: The test site complies with ANSI C63.4 2014 requirement.

FCC designation No.: TW1190 and TW0007

1.5 Applicable Standards

According to the specifications of the manufacturer, the EUT must comply with the requirements of the following standards:

- ♦ FCC Part 15 Subpart C §15.247
- ♦ FCC KDB Publication No. 558074 D01 DTS Meas. Guidance v05r02
- ♦ FCC KDB 414788 D01 Radiated Test Site v01r01.
- ♦ FCC KDB 662911 D01 Multiple Transmitter Output v02r01.
- ♦ ANSI C63.10-2013

Remark:

1. All test items were verified and recorded according to the standards and without any deviation during the test.
2. This EUT has also been tested and complied with the requirements of FCC Part 15, Subpart B, recorded in a separate test report.



2 Test Configuration of Equipment Under Test

- a. The EUT has been associated with peripherals and configuration operated in a manner tended to maximize its emission characteristics in a typical application. Frequency range investigated: conduction emission (150 kHz to 30 MHz), radiation emission (9 kHz to the 10th harmonic of the highest fundamental frequency or to 40 GHz, whichever is lower). For radiated measurement, pre-scanned in three orthogonal panels, X, Y, Z. The worst cases (X plane with adapter ; Z plane with WPC) were recorded in this report.

- b. AC power line Conducted Emission was tested under maximum output power.

2.1 Carrier Frequency and Channel

Frequency Band	Channel	Freq. (MHz)	Channel	Freq. (MHz)
2400-2483.5 MHz	1	2412	8	2447
	2	2417	9	2452
	3	2422	10	2457
	4	2427	11	2462
	5	2432	12	2467
	6	2437	13	2472
	7	2442		



2.2 Test Mode

Final test modes are considering the modulation and worse data rates as below table.

MIMO Antenna

Modulation	Data Rate
802.11b	1 Mbps
802.11g	6 Mbps
802.11n HT20	MCS0
802.11ac VHT20 (Covered by HT20)	MCS0

Test Cases	
AC Conducted Emission	Mode 1 :WLAN (2.4GHz) Link + Bluetooth Link + USB Cable (Type C) (Charging from AC Adapter 1) Mode 2 :WLAN (2.4GHz) Link + Bluetooth Link + Earphone (Type C) + Wireless Charging
Remark: 1. The worst case of conducted emission is mode 2; only the test data of it was reported. 2. For Radiated Test Cases, the tests were performed with Adapter 1.	

2.3 Connection Diagram of Test System

<WLAN Tx Mode>

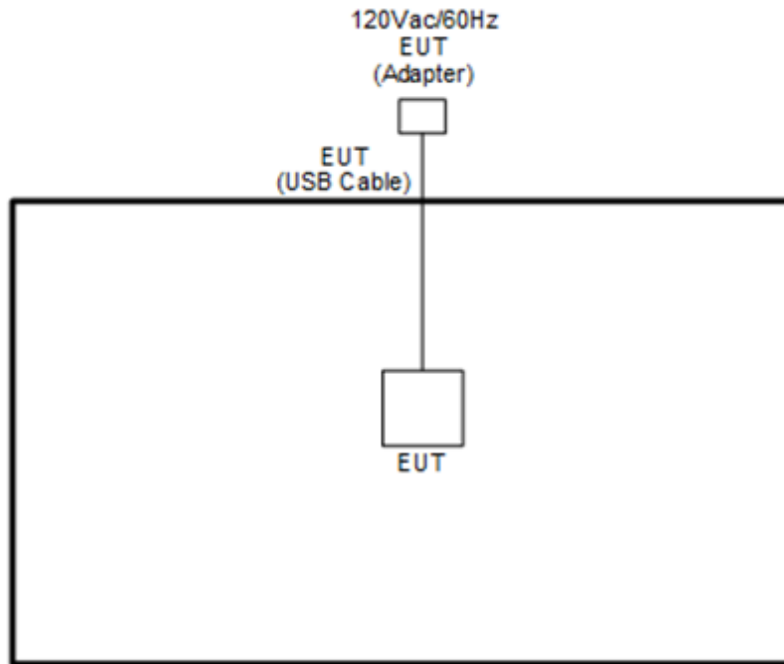

<WLAN Tx with WPC Charging Mode>

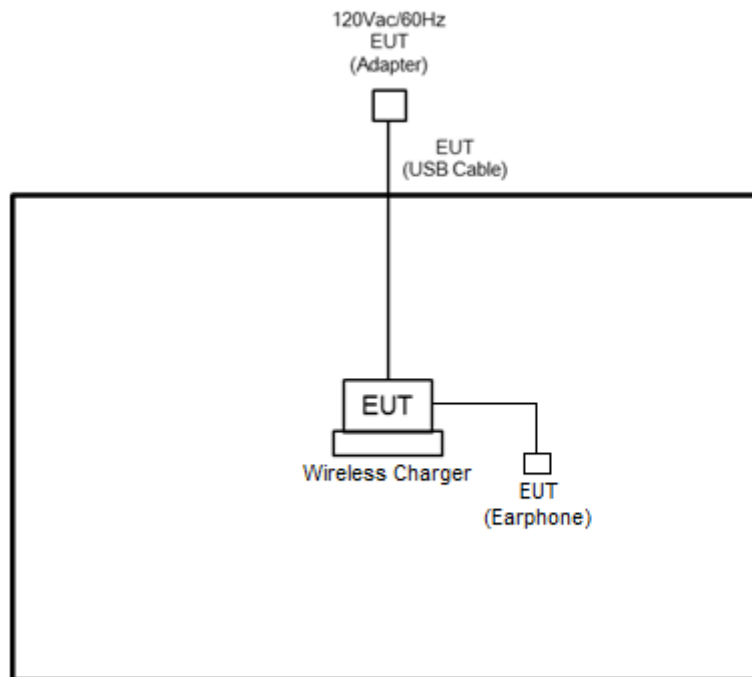

<AC Conducted Emissions Mode>

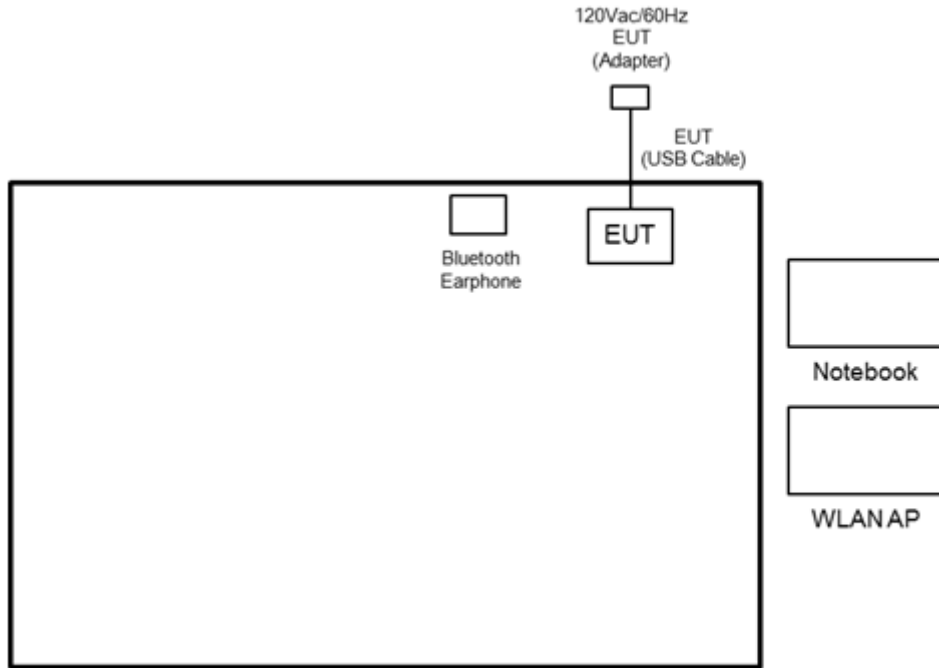

<AC Conducted Emissions with WPC Charging Mode>

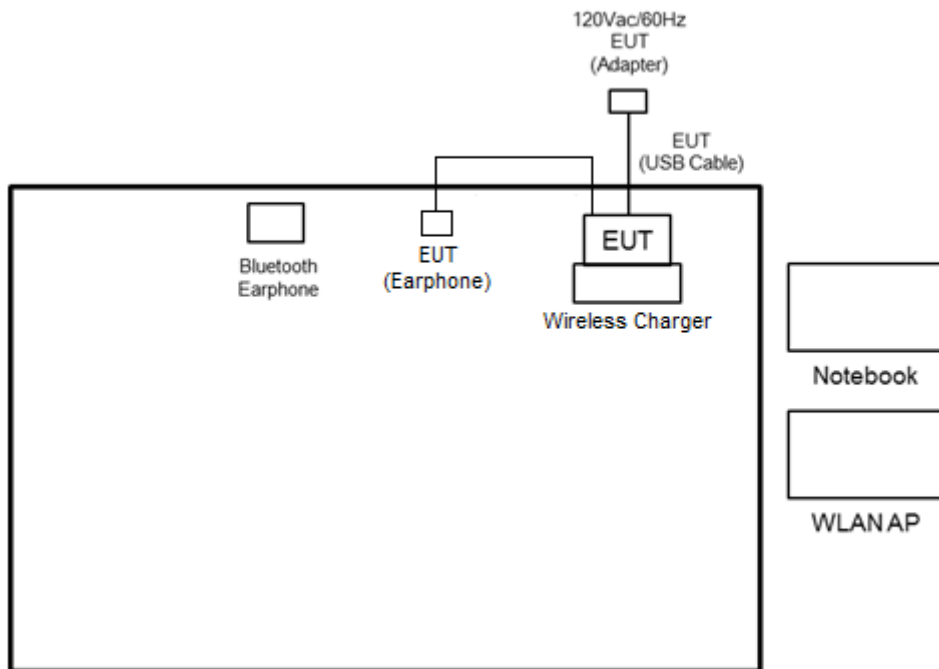

2.4 Support Unit used in test configuration and system

Item	Equipment	Trade Name	Model Name	FCC ID	Data Cable	Power Cord
1.	WLAN AP	ASUS	RT-AC66U	MSQ-RTAC66U	N/A	Unshielded, 1.8 m
2.	Notebook	DELL	Latitude E6320	FCC DoC/ Contains FCC ID: QDS-BRCM1054	N/A	AC I/P: Unshielded, 1.2 m DC O/P: Shielded, 1.8 m
3.	Bluetooth Earphone	Google	G015B	SZGG015B	N/A	N/A
4.	Wireless charger	Google	G019C	2APYSG019C	N/A	Unshielded, 1.95m

2.5 EUT Operation Test Setup

The RF test items, utility “QRCT version : 3.0.271.0” was installed in Notebook which was programmed in order to make the EUT get into the engineering modes to provide channel selection, power level, data rate and the application type and for continuous transmitting signals.

2.6 Measurement Results Explanation Example

For all conducted test items:

The offset level is set in the spectrum analyzer to compensate the RF cable loss and attenuator factor between EUT conducted output port and spectrum analyzer. With the offset compensation, the spectrum analyzer reading level is exactly the EUT RF output level.

Example:

The spectrum analyzer offset is derived from RF cable loss and attenuator factor.

Offset = RF cable loss + attenuator factor.

Following shows an offset computation example with cable loss 4.2 dB and 10dB attenuator.

$$\begin{aligned}
 \text{Offset(dB)} &= \text{RF cable loss(dB)} + \text{attenuator factor(dB)}. \\
 &= 4.2 + 10 = 14.2 \text{ (dB)}
 \end{aligned}$$

3 Test Result

3.1 6dB and 99% Bandwidth Measurement

3.1.1 Limit of 6dB and 99% Bandwidth

The minimum 6 dB bandwidth shall be at least 500 kHz.

3.1.2 Measuring Instruments

See list of measuring equipment of this test report.

3.1.3 Test Procedures

1. The testing follows the ANSI C63.10 Section 6.9.3 (OBW) and 11.8.1 (6dB BW).
2. The RF output of EUT was connected to the spectrum analyzer by RF cable and attenuator. The path loss was compensated to the results for each measurement.
3. Set to the maximum power setting and enable the EUT transmit continuously.
4. Make the measurement with the spectrum analyzer's resolution bandwidth (RBW) = 100 kHz. Set the Video bandwidth (VBW) = 300 kHz. In order to make an accurate measurement. The 6 dB bandwidth must be greater than 500 kHz.
5. For 99% Bandwidth Measurement, the spectrum analyzer's resolution bandwidth (RBW) is set 1-5% of the emission bandwidth and set the Video bandwidth (VBW) $\geq 3 * RBW$.
6. Measure and record the results in the test report.

3.1.4 Test Setup





3.1.5 Test Result of 6dB and 99% Occupied Bandwidth

Please refer to Appendix A.

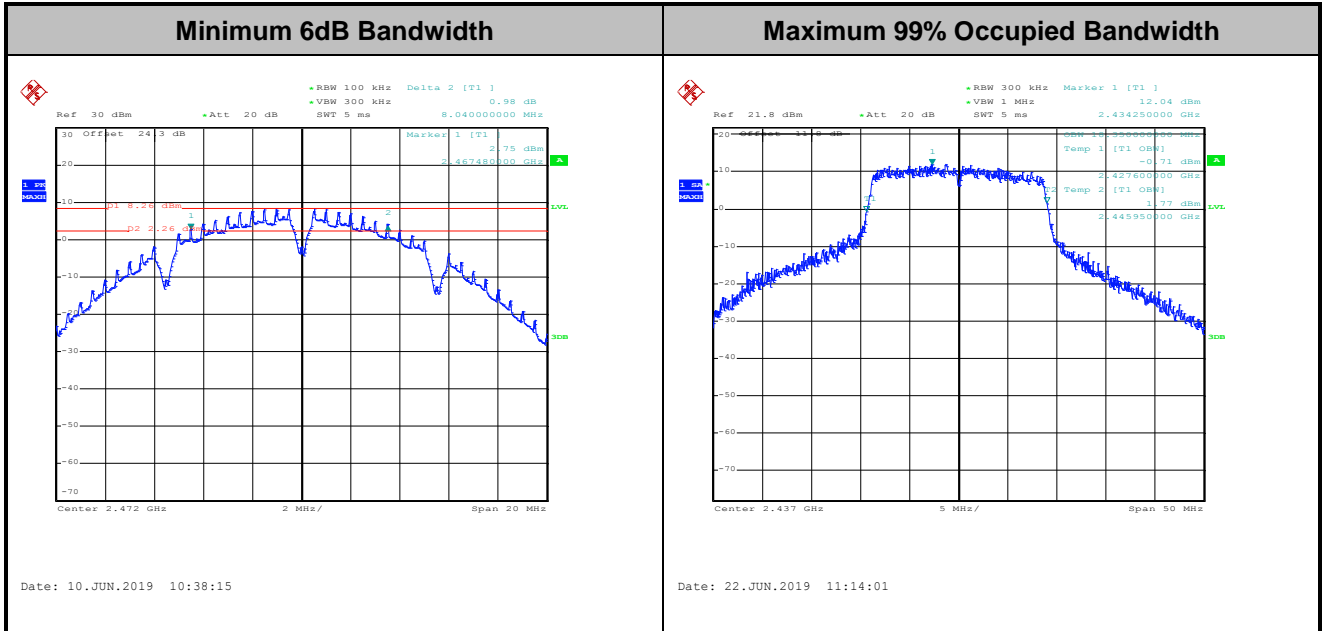

Note: The occupied channel bandwidth is maintained within the band of operation for all of the modulations.

3.2 Output Power Measurement

3.2.1 Limit of Output Power

For systems using digital modulation in the 2400-2483.5MHz, the limit for peak output power is 30dBm. If transmitting antenna with directional gain greater than 6dBi is used, the peak output power from the intentional radiator shall be reduced below the above stated value by the amount in dB that the directional gain of the antenna exceeds 6 dBi. In case of point-to-point operation, the limit has to be reduced by 1dB for every 3dB that the directional gain of the antenna exceeds 6dBi.

3.2.2 Measuring Instruments

See list of measuring equipment of this test report.

3.2.3 Test Procedures

1. For Average Power, the testing follows ANSI C63.10 Section 11.9.2.3.2 Method AVGPM-G
2. The RF output of EUT was connected to the power meter by RF cable and attenuator. The path loss was compensated to the results for each measurement.
3. Set to the maximum power setting and enable the EUT transmit continuously.
4. Measure the conducted output power and record the results in the test report.
5. For MIMO mode, calculation method follows FCC KDB 662911 D01 Multiple Transmitter Output v02r01.

3.2.4 Test Setup

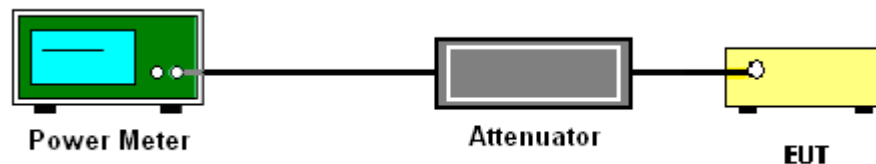

3.2.5 Test Result of Average Output Power

Please refer to Appendix A.

3.3 Power Spectral Density Measurement

3.3.1 Limit of Power Spectral Density

The peak power spectral density shall not be greater than 8dBm in any 3kHz band at any time interval of continuous transmission.

3.3.2 Measuring Instruments

See list of measuring equipment of this test report.

3.3.3 Test Procedures

1. The testing follows the ANSI C63.10 Section 11.10.2 Method PKPSD.
2. The RF output of EUT was connected to the spectrum analyzer by RF cable and attenuator. The path loss was compensated to the results for each measurement.
3. Set to the maximum power setting and enable the EUT transmit continuously.
4. Make the measurement with the spectrum analyzer's resolution bandwidth (RBW) = 3 kHz. Video bandwidth VBW = 10 kHz In order to make an accurate measurement, set the span to 1.5 times DTS Channel Bandwidth. (6dB BW)
5. Detector = peak, Sweep time = auto couple, Trace mode = max hold, Allow trace to fully stabilize. Use the peak marker function to determine the maximum power level.
6. Measure and record the results in the test report.
7. For MIMO mode, calculation method follows FCC KDB 662911 D01 Multiple Transmitter Output v02r01.

If measurements performed using method (2) plus $10 \log(N)$ exceeds the emission limit, the test should choose method (1) before declaring that the device fails the emission limit.

Method (1): Measure and sum the spectra across the outputs.

The total final Power Spectral Density is from a device with 2 transmitter outputs. The spectrum measurements of the individual outputs are all performed with the same span and number of points, the spectrum value in the first spectral bin of output 1 is summed with that in the first spectral bin of output 2 to obtain the value for the first frequency bin of the summed spectrum.

Method (2): Measure and add $10 \log(N)$ dB, where N is the number of outputs. (N=2)

3.3.4 Test Setup

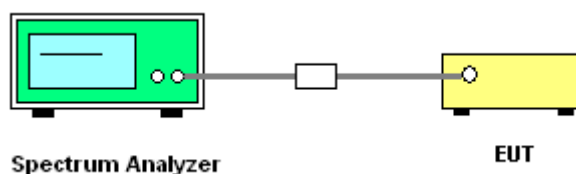



3.3.5 Test Result of Power Spectral Density

Please refer to Appendix A.

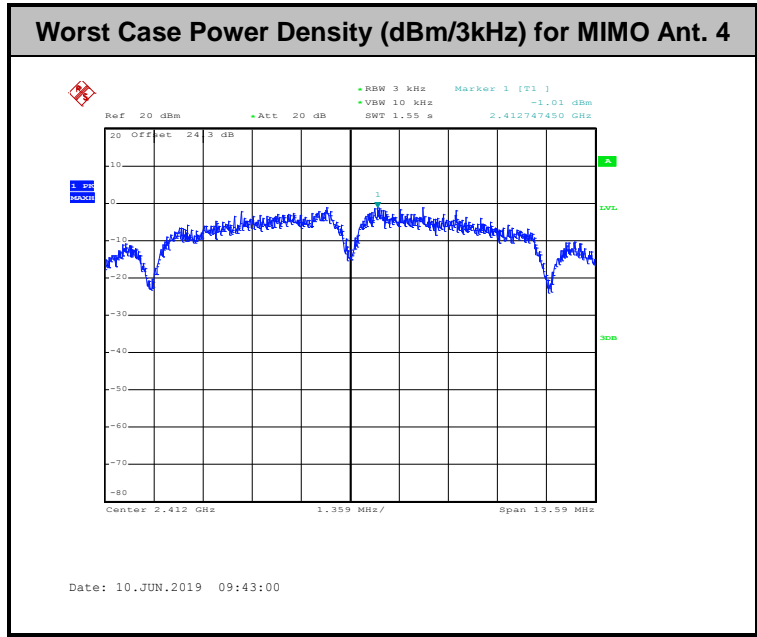
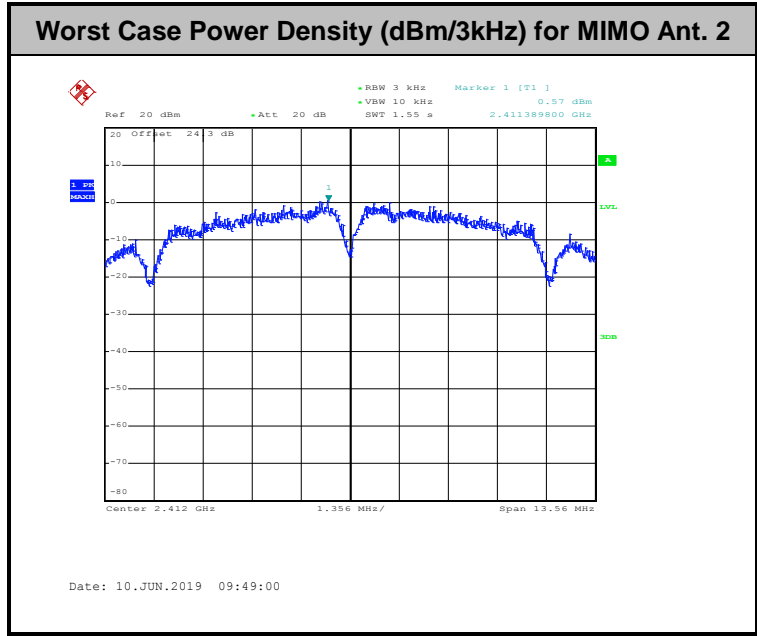

3.4 Conducted Band Edges and Spurious Emission Measurement

3.4.1 Limit of Conducted Band Edges and Spurious Emission Measurement

In any 100 kHz bandwidth outside of the authorized frequency band, the emissions which fall in the non-restricted bands shall be attenuated at least 20 dB / 30dB relative to the maximum PSD level in 100 kHz by RF conducted measurement.

3.4.2 Measuring Instruments

See list of measuring equipment of this test report.

3.4.3 Test Procedures

1. The testing follows the ANSI C63.10 Section 11.11.3 Emission level measurement.
2. The RF output of EUT was connected to the spectrum analyzer by RF cable and attenuator. The path loss was compensated to the results for each measurement.
3. Set to the maximum power setting and enable the EUT transmit continuously.
4. Set RBW = 100 kHz, VBW=300 kHz, Peak Detector. Unwanted Emissions measured in any 100 kHz bandwidth outside of the authorized frequency band shall be attenuated by at least 20 dB relative to the maximum in-band peak PSD level in 100 kHz when maximum peak conducted output power procedure is used. If the transmitter complies with the conducted power limits based on the use of RMS averaging over a time interval, the attenuation required under this paragraph shall be 30 dB instead of 20 dB per 15.247(d).
5. Measure and record the results in the test report.
6. The RF fundamental frequency should be excluded against the limit line in the operating frequency band.

3.4.4 Test Setup

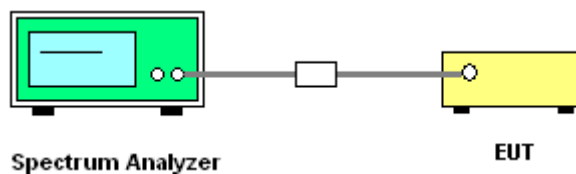

3.4.5 Test Result of Conducted Band Edges and Spurious Emission

Test Engineer : Hank Hsu	Temperature : 21~25°C
	Relative Humidity : 51~54%



Number of TX = 2, Ant. 2 (Measured)

Test Mode :	802.11b	Test Channel :	01
-------------	---------	----------------	----

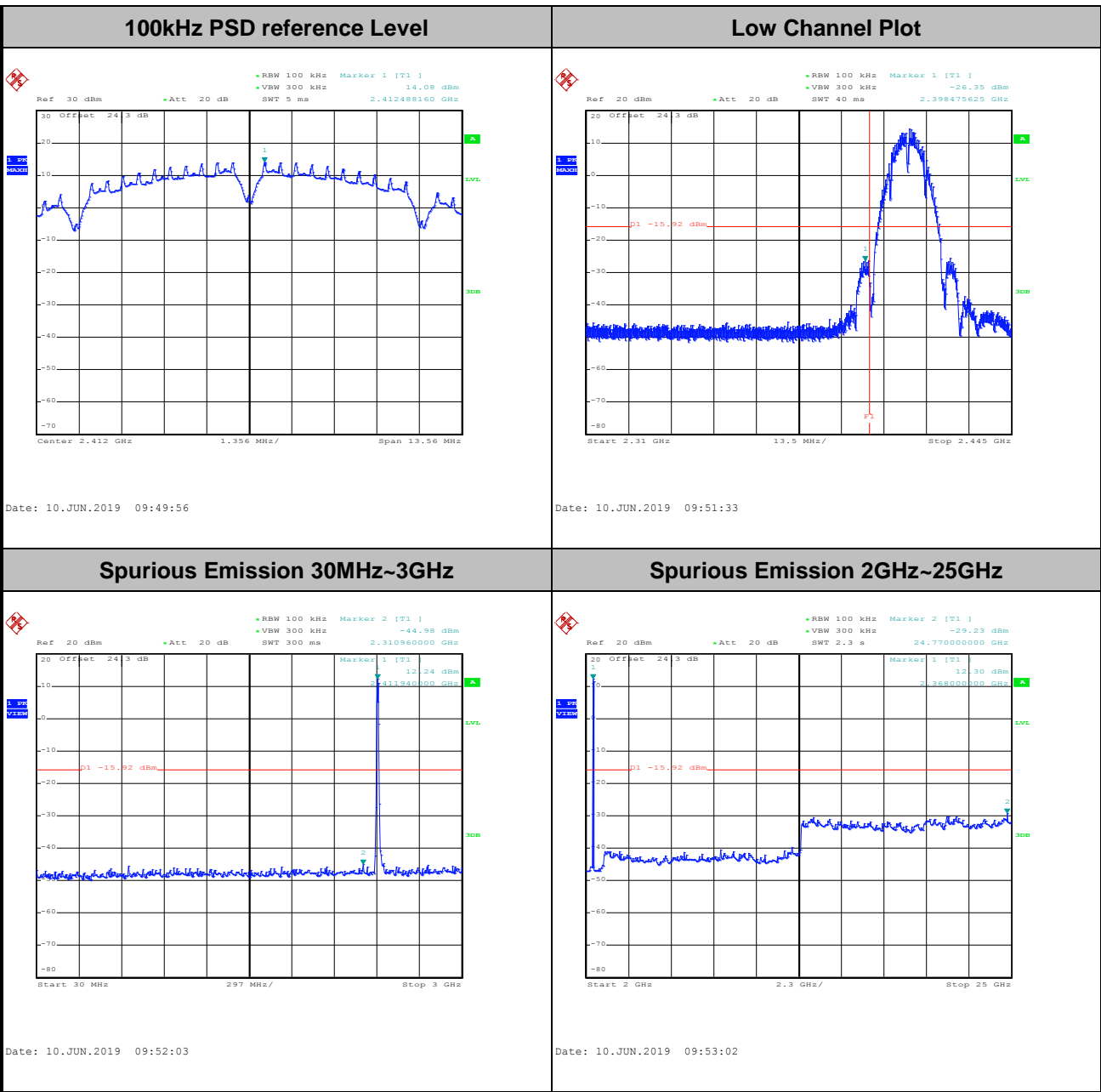



Test Mode :	802.11b	Test Channel :	06
-------------	---------	----------------	----

100kHz PSD reference Level	Mid Channel Plot
-----------------------------------	-------------------------

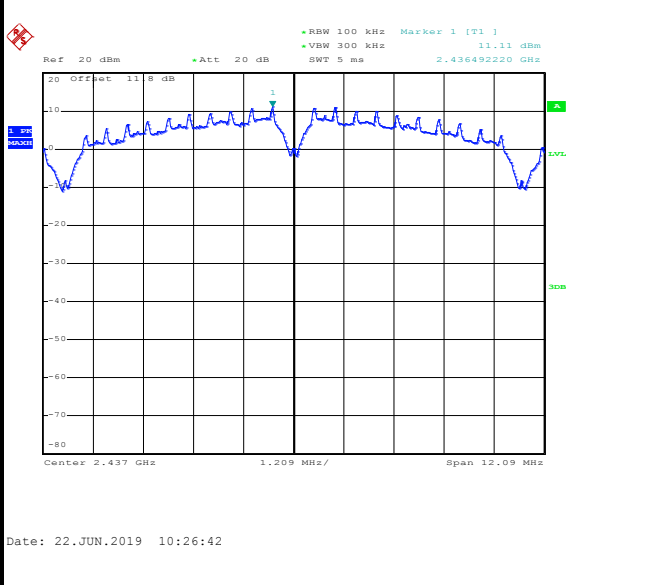

Spurious Emission 30MHz~3GHz	Spurious Emission 2GHz~25GHz
-------------------------------------	-------------------------------------

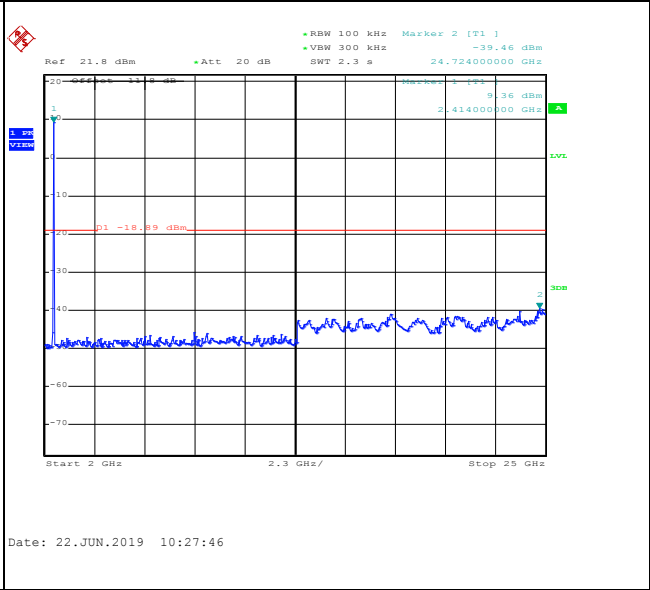
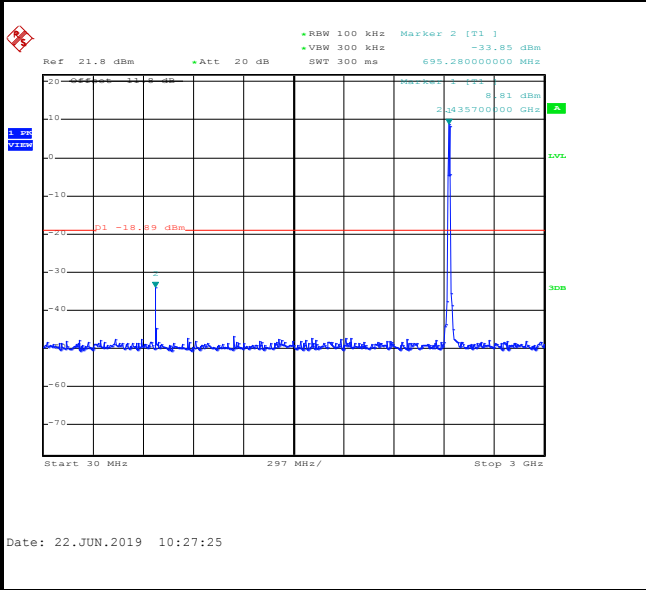



Test Mode :	802.11b	Test Channel :	11
-------------	---------	----------------	----

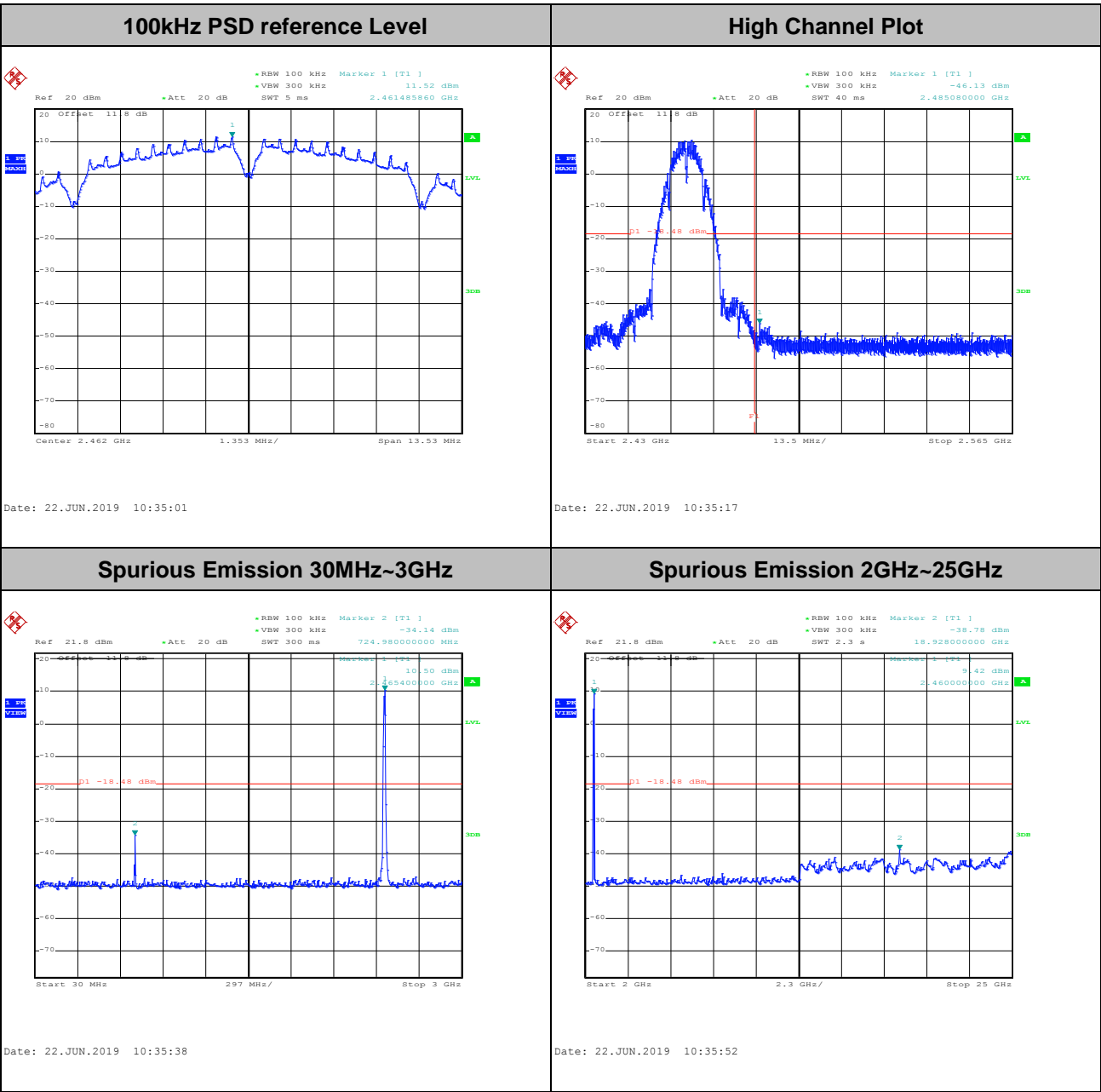



Test Mode :	802.11b	Test Channel :	12
-------------	---------	----------------	----

100kHz PSD reference Level	High Channel Plot
-----------------------------------	--------------------------

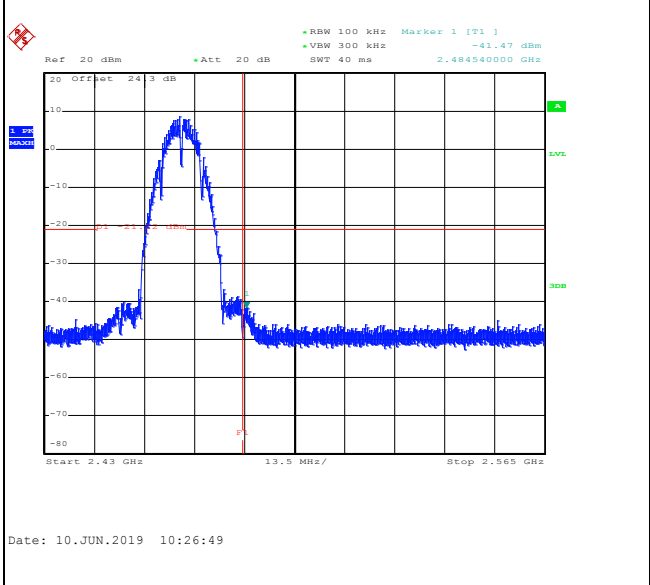
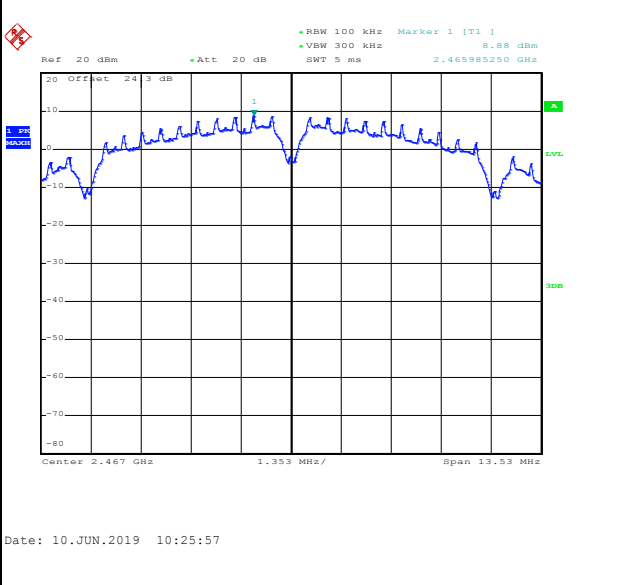

Spurious Emission 30MHz~3GHz	Spurious Emission 2GHz~25GHz
-------------------------------------	-------------------------------------

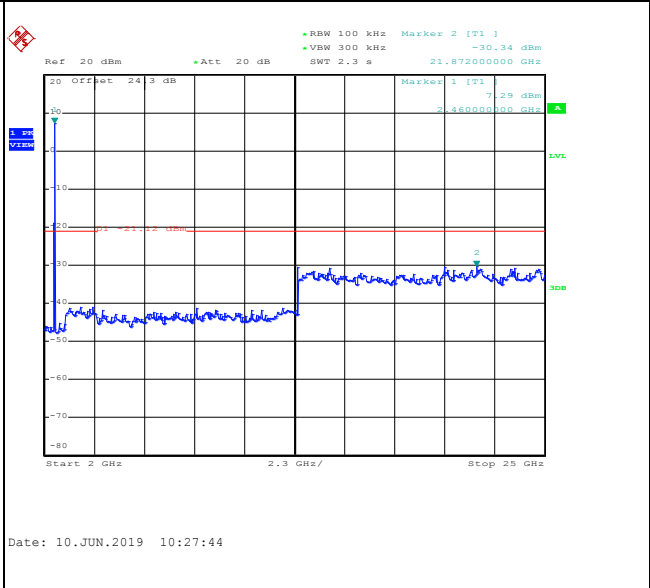
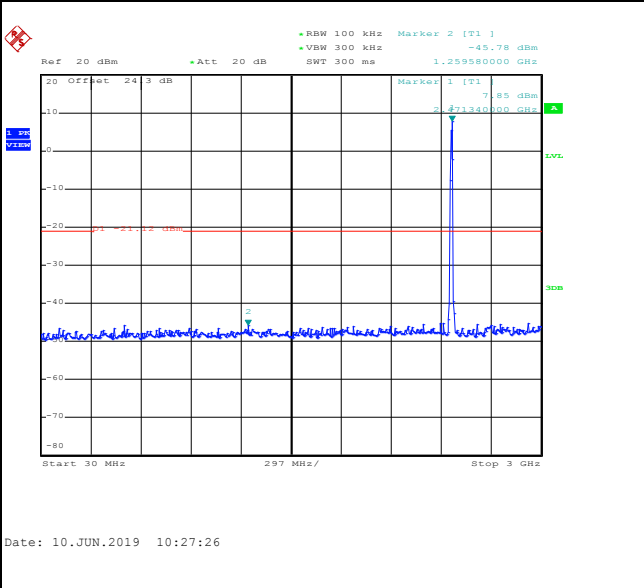



Test Mode :	802.11b	Test Channel :	13
-------------	---------	----------------	----

100kHz PSD reference Level	High Channel Plot
-----------------------------------	--------------------------

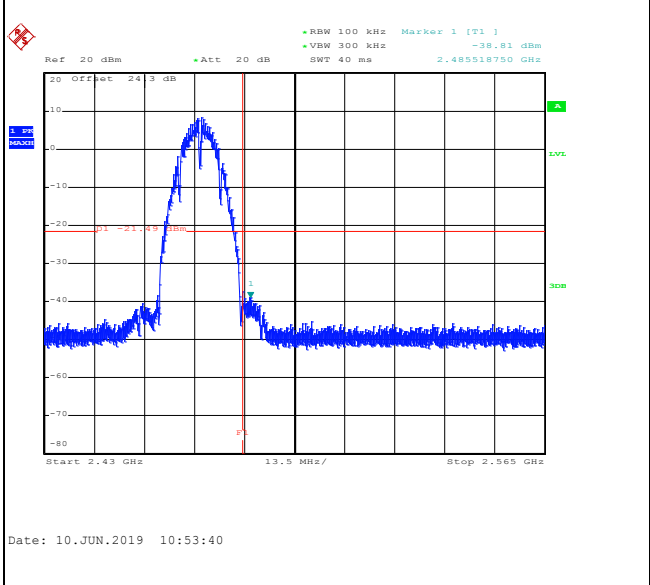
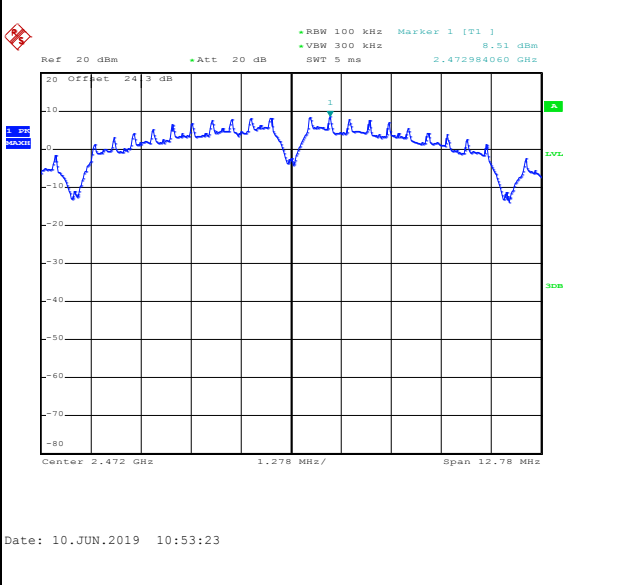

Spurious Emission 30MHz~3GHz	Spurious Emission 2GHz~25GHz
-------------------------------------	-------------------------------------

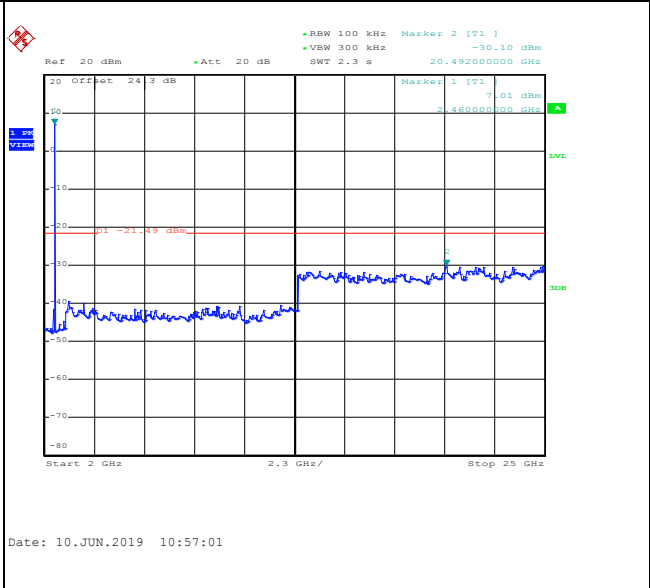
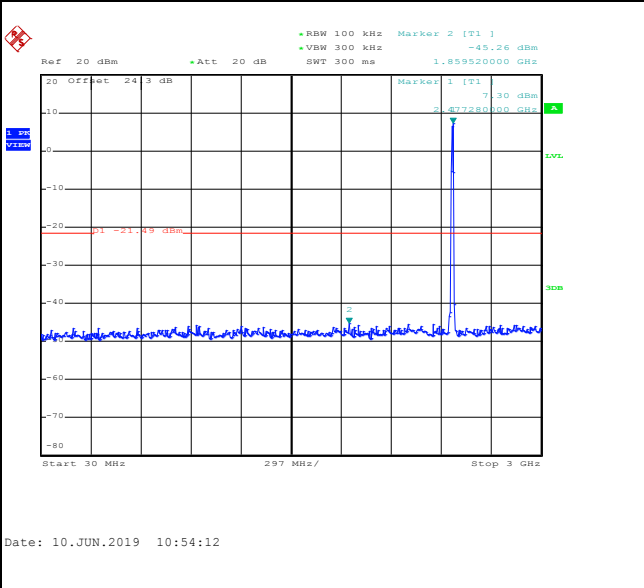



Test Mode :	802.11g	Test Channel :	01
-------------	---------	----------------	----

100kHz PSD reference Level	Low Channel Plot
-----------------------------------	-------------------------

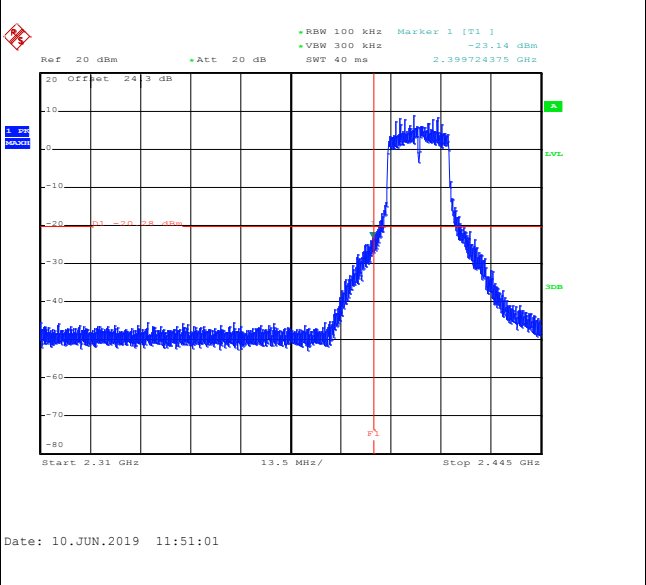
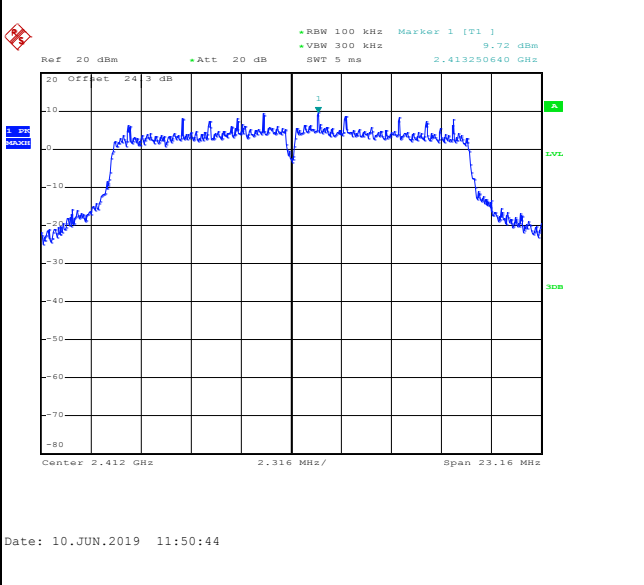

Spurious Emission 30MHz~3GHz	Spurious Emission 2GHz~25GHz
-------------------------------------	-------------------------------------

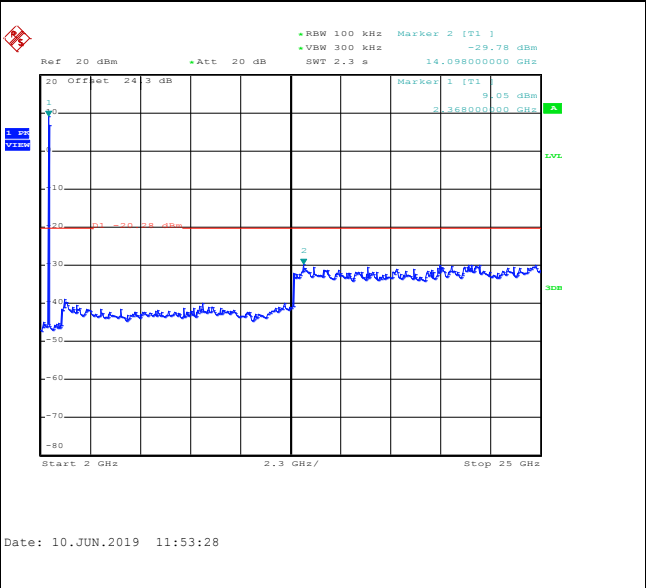
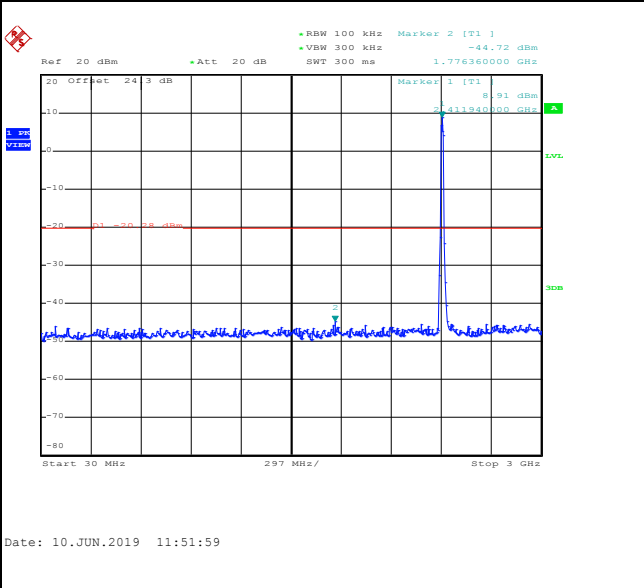



Test Mode :	802.11g	Test Channel :	06
-------------	---------	----------------	----

100kHz PSD reference Level	Mid Channel Plot
-----------------------------------	-------------------------

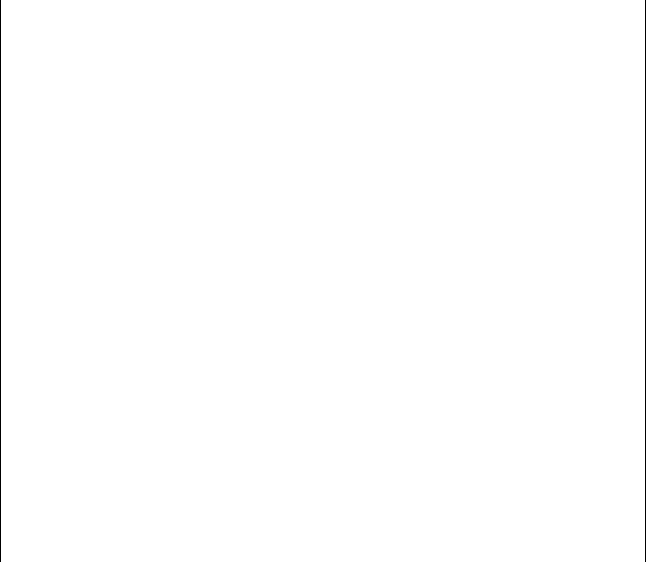
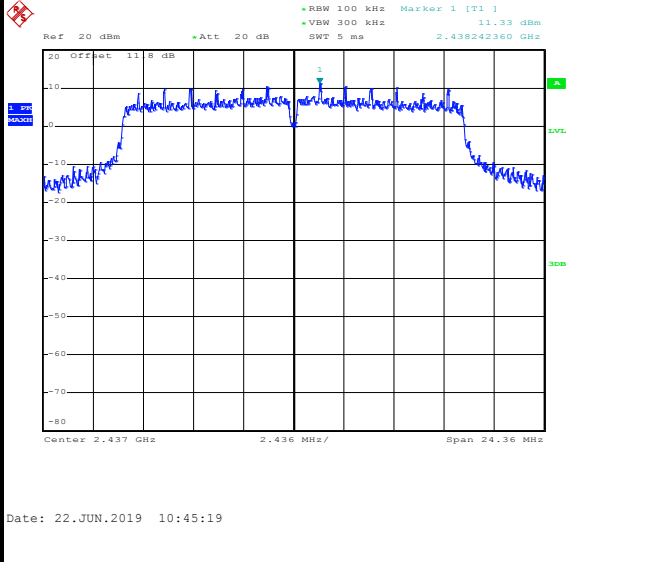

Spurious Emission 30MHz~3GHz	Spurious Emission 2GHz~25GHz
-------------------------------------	-------------------------------------

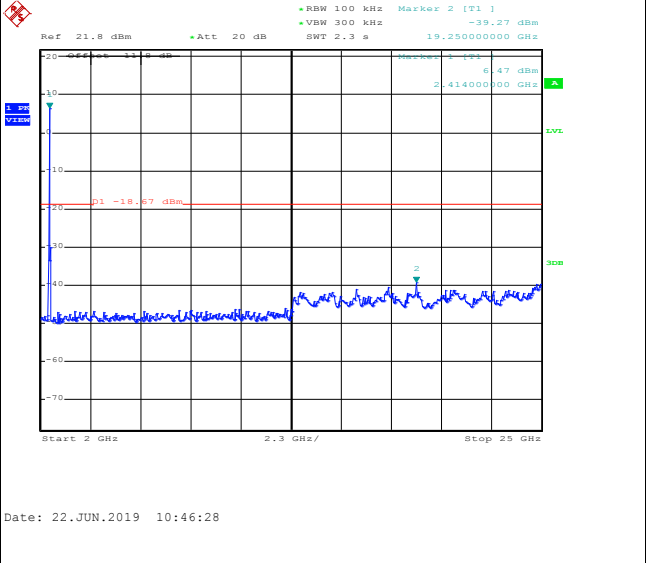
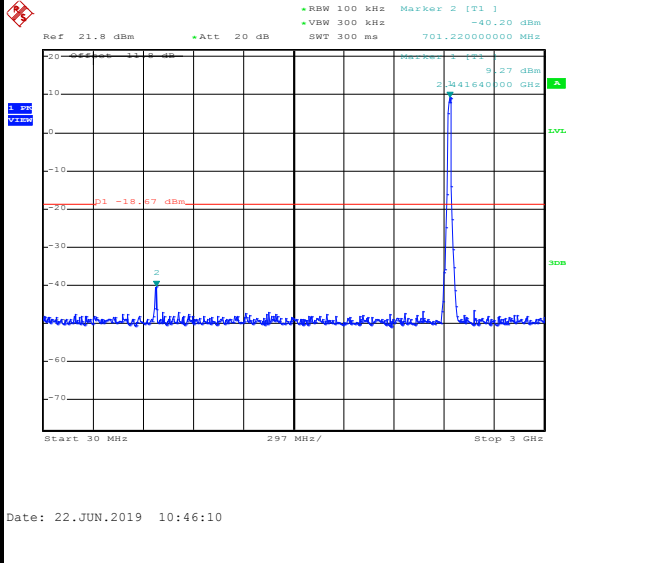



Test Mode :	802.11g	Test Channel :	11
-------------	---------	----------------	----

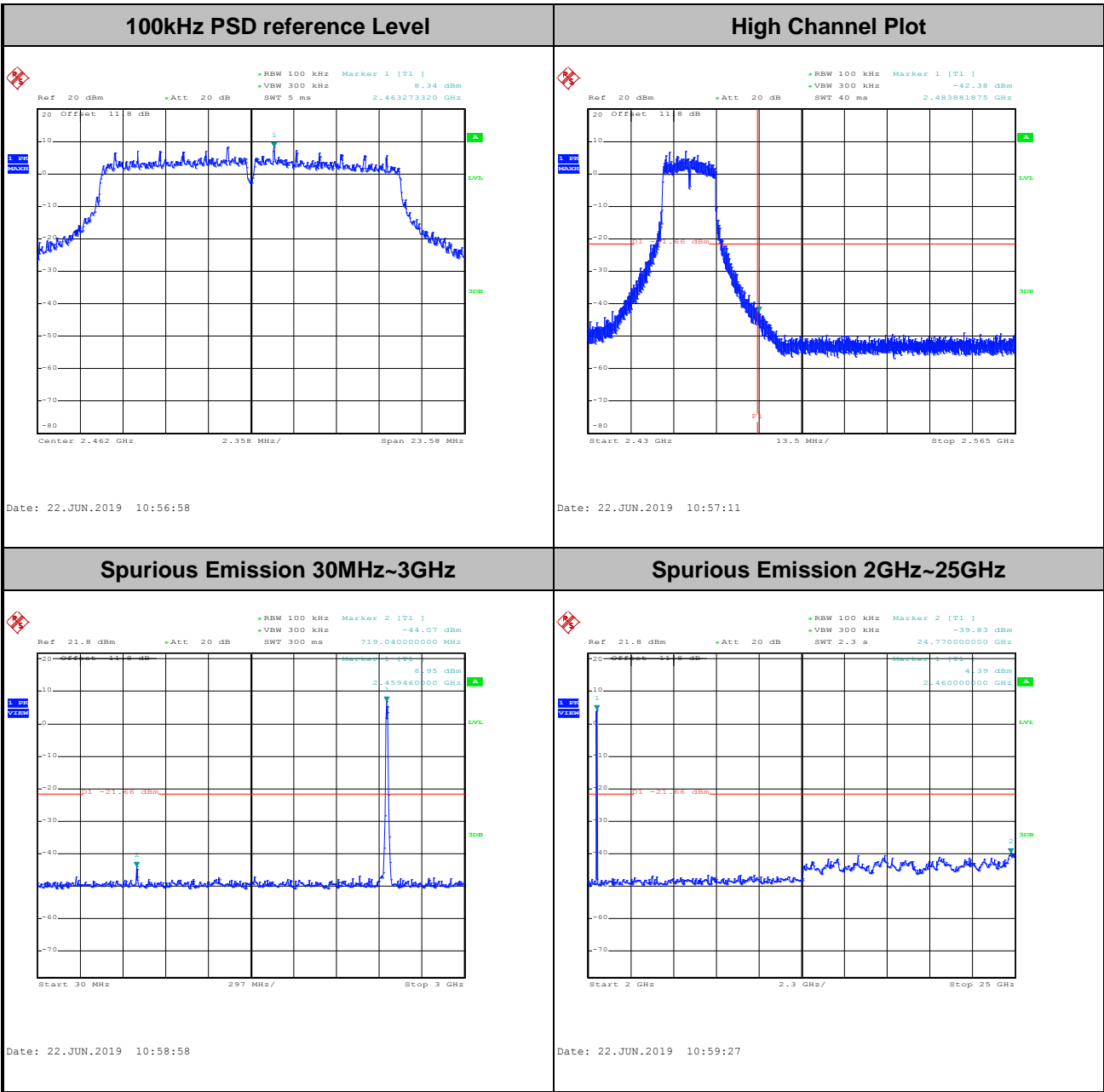



Test Mode :	802.11g	Test Channel :	12
-------------	---------	----------------	----

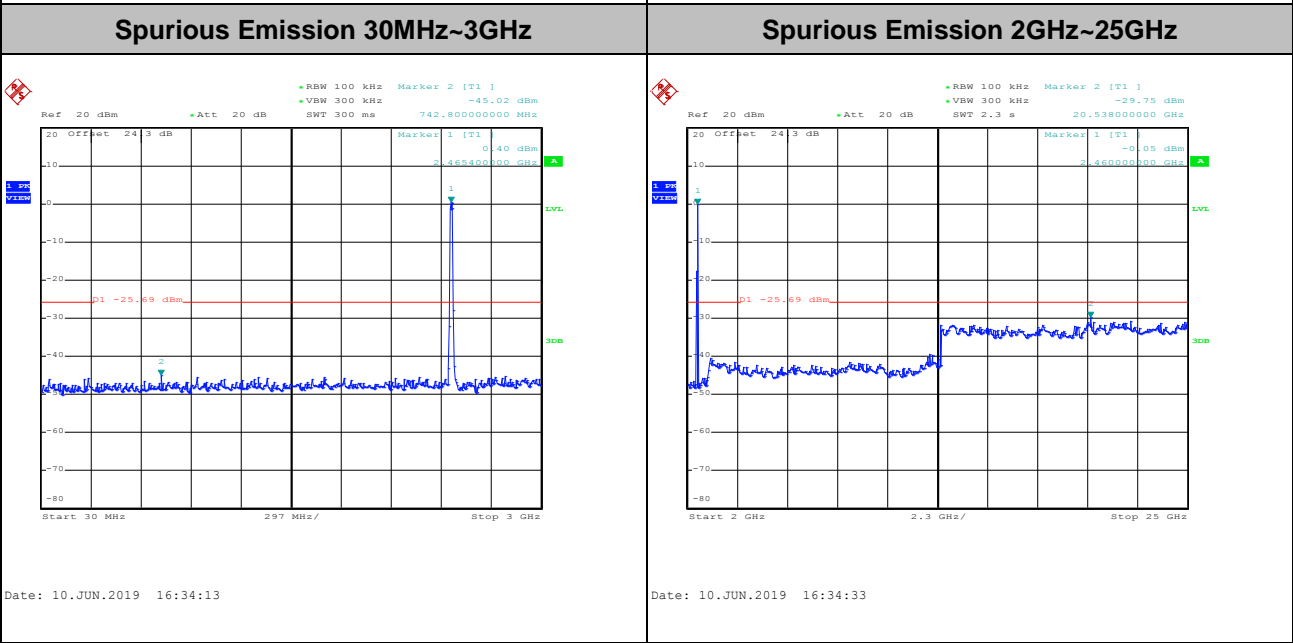
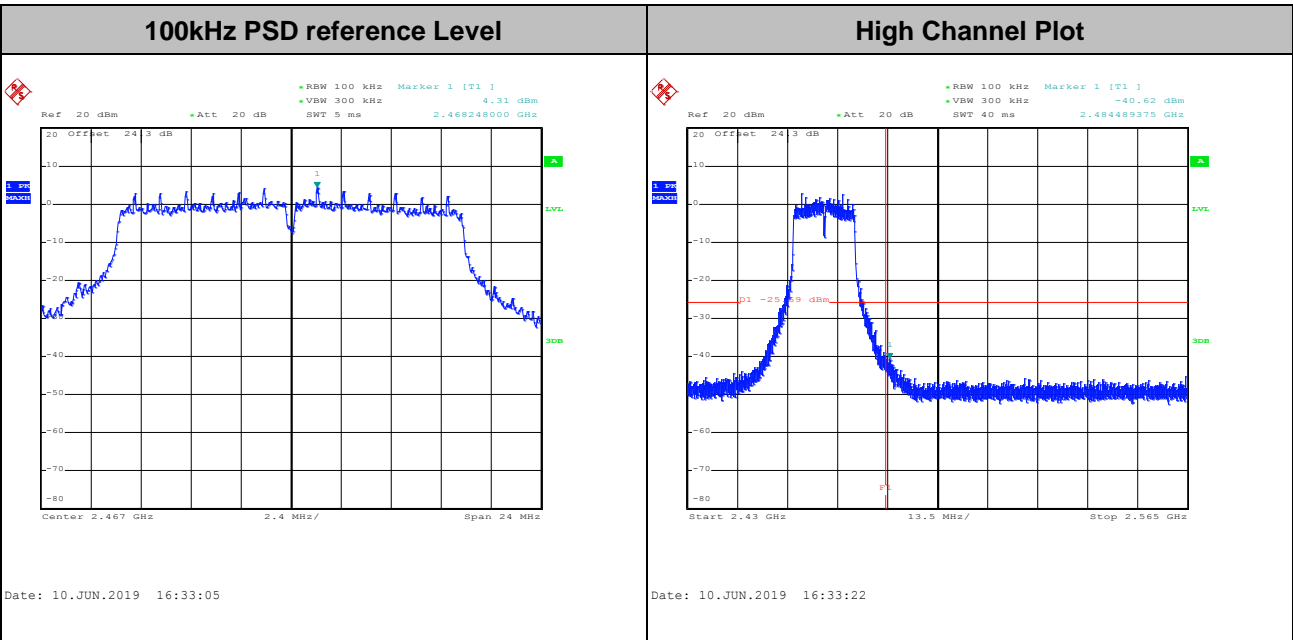



Test Mode :	802.11g	Test Channel :	13
-------------	---------	----------------	----

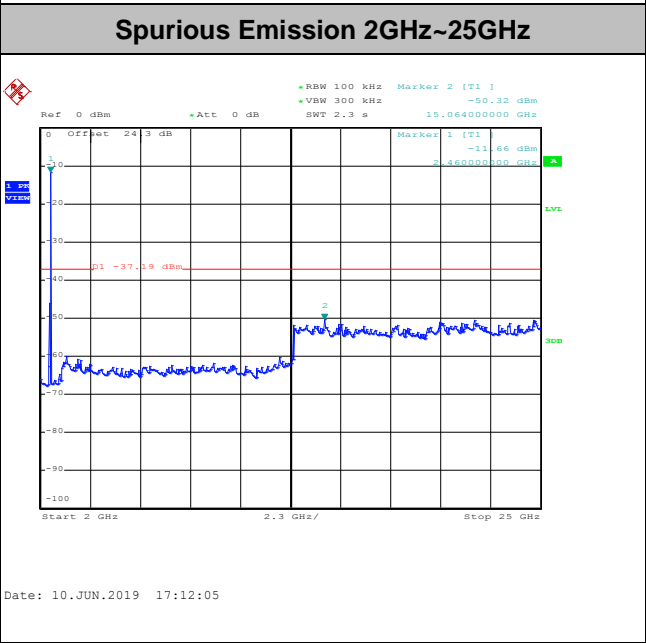
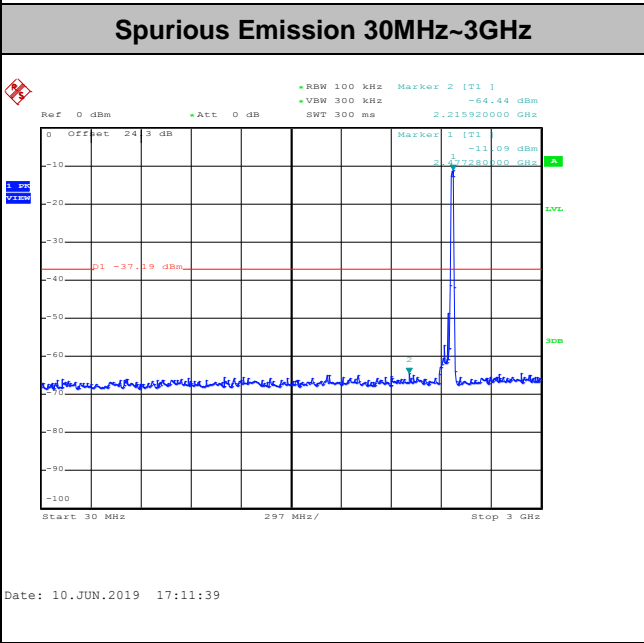
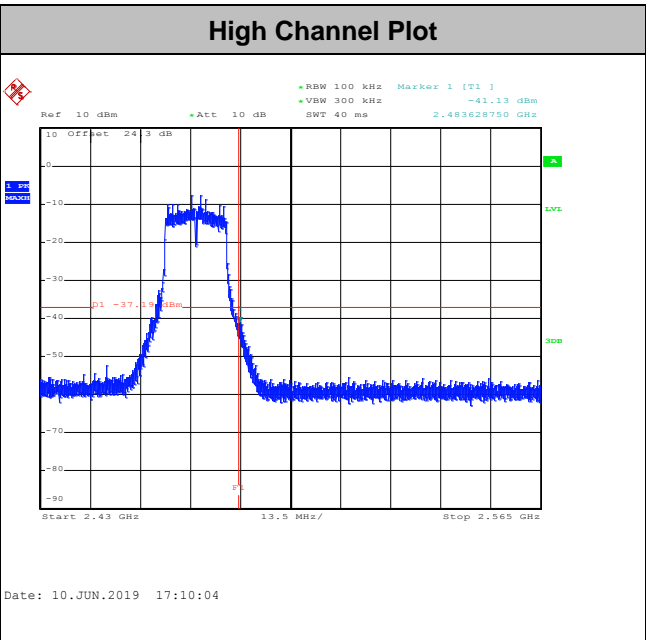
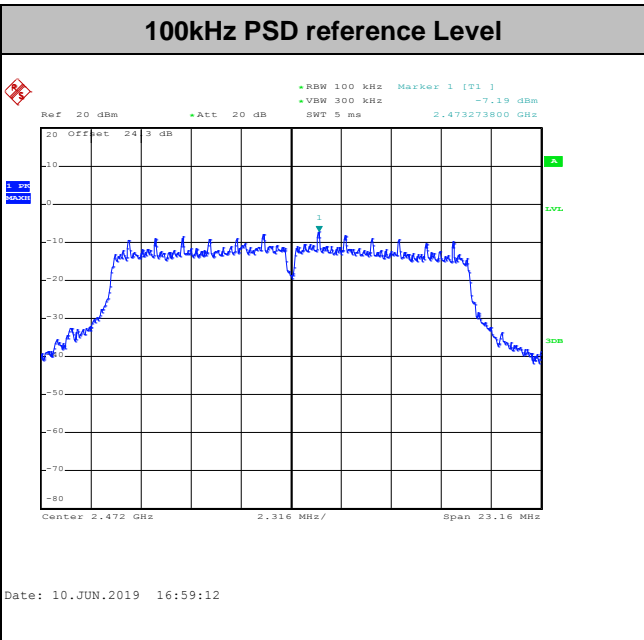



Test Mode :	802.11n HT20	Test Channel :	01
-------------	--------------	----------------	----

100kHz PSD reference Level	Low Channel Plot
-----------------------------------	-------------------------

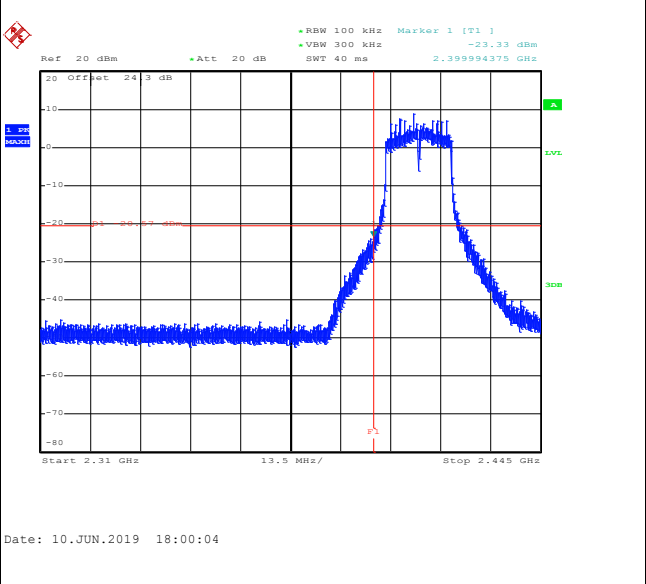
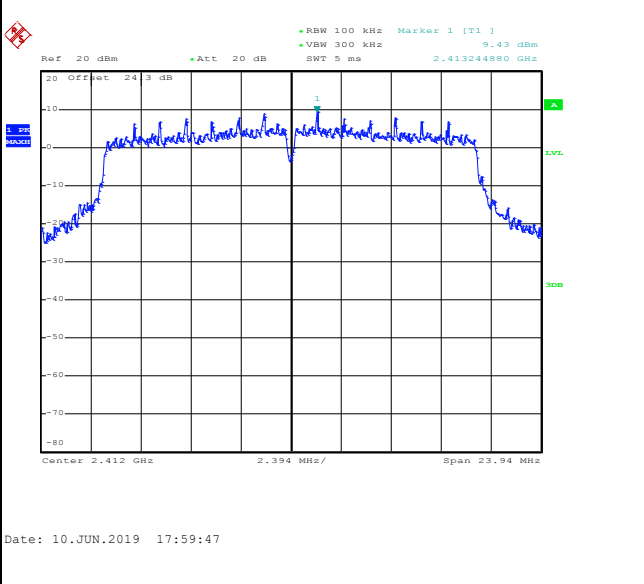

Spurious Emission 30MHz~3GHz	Spurious Emission 2GHz~25GHz
-------------------------------------	-------------------------------------

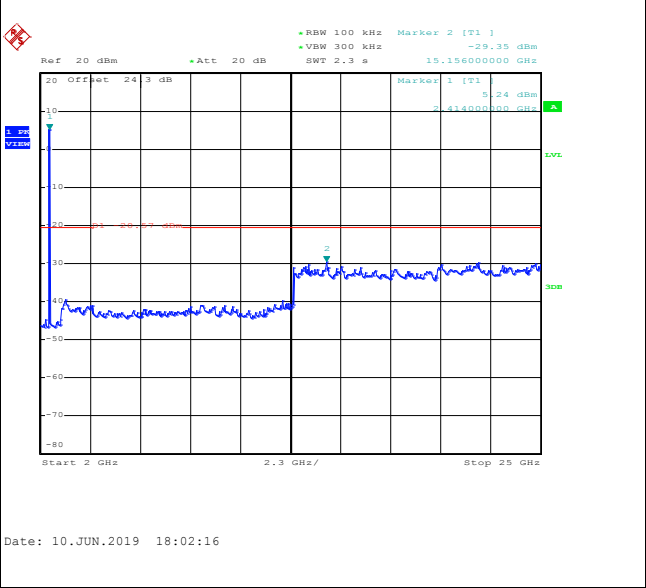
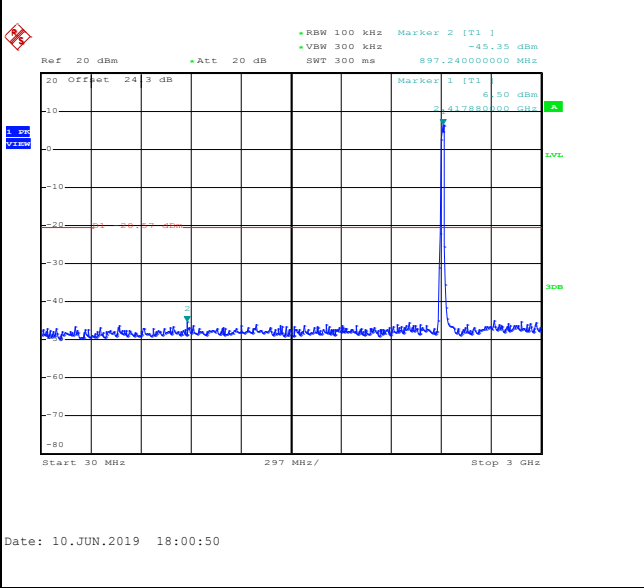



Test Mode :	802.11n HT20	Test Channel :	06
-------------	--------------	----------------	----

100kHz PSD reference Level	Mid Channel Plot
-----------------------------------	-------------------------

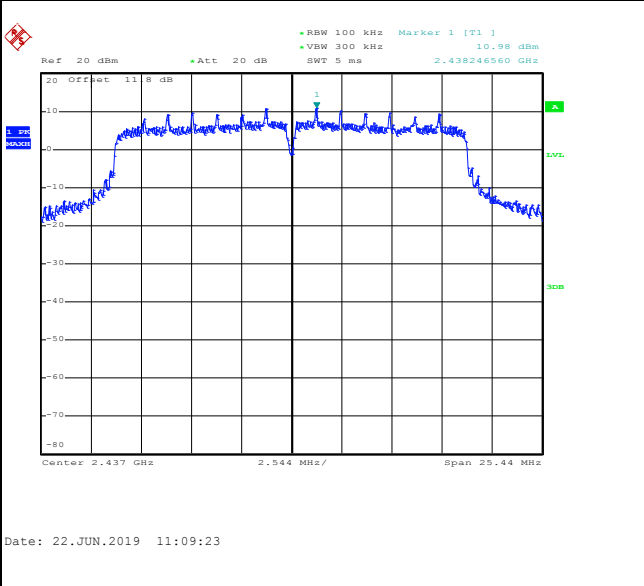

Spurious Emission 30MHz~3GHz	Spurious Emission 2GHz~25GHz
-------------------------------------	-------------------------------------

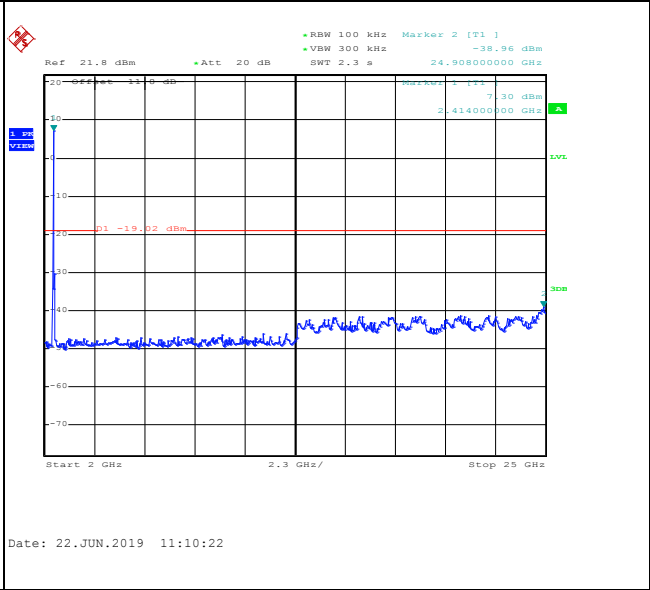
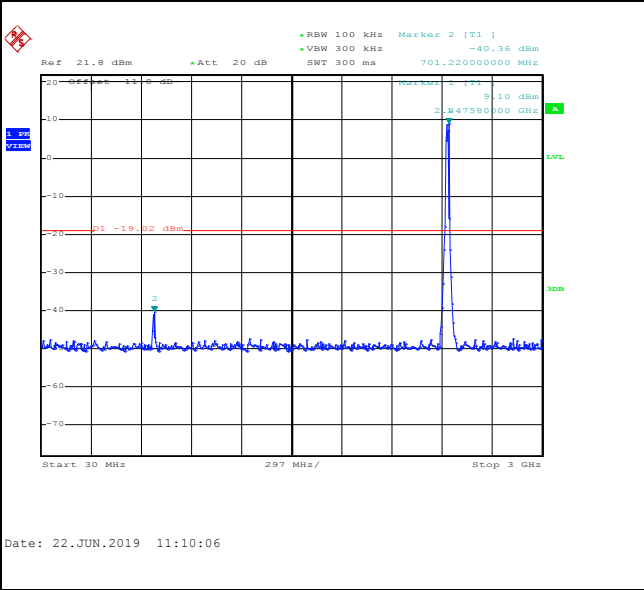



Test Mode :	802.11n HT20	Test Channel :	11
-------------	--------------	----------------	----

100kHz PSD reference Level	High Channel Plot
-----------------------------------	--------------------------

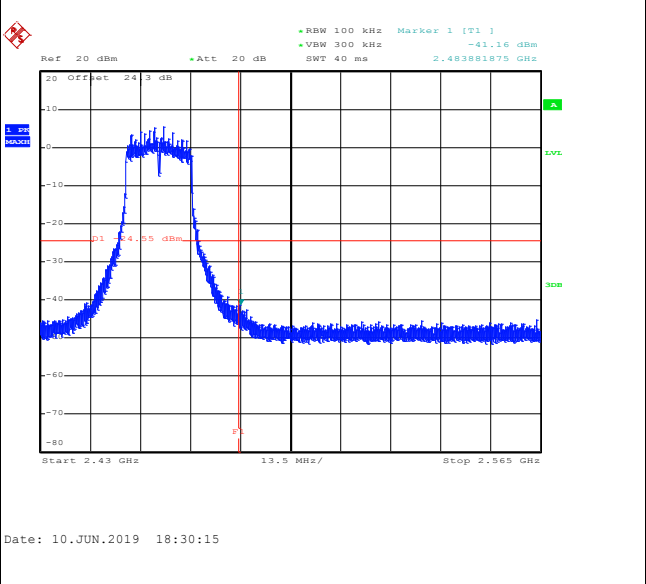
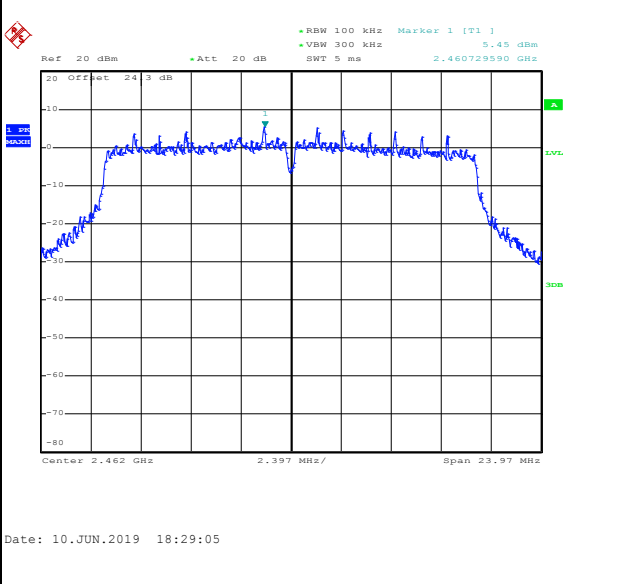

Spurious Emission 30MHz~3GHz	Spurious Emission 2GHz~25GHz
-------------------------------------	-------------------------------------

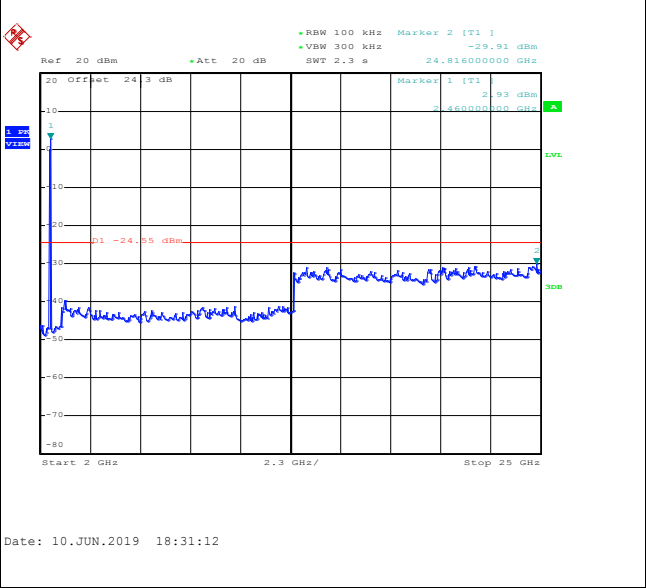
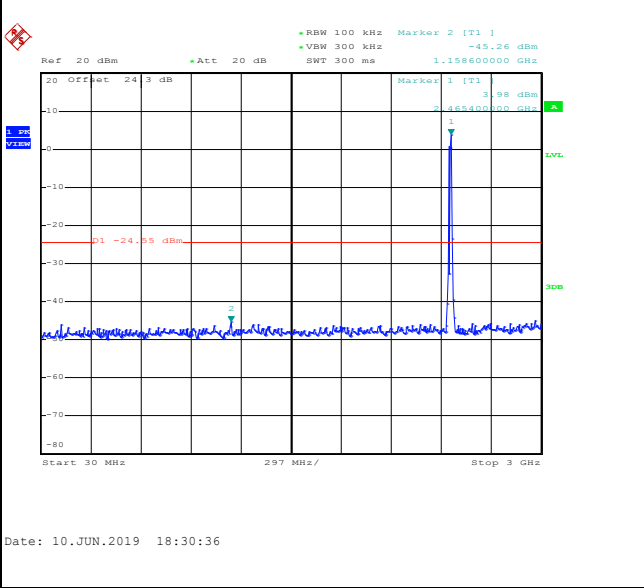



Test Mode :	802.11n HT20	Test Channel :	12
-------------	--------------	----------------	----

100kHz PSD reference Level	High Channel Plot
-----------------------------------	--------------------------

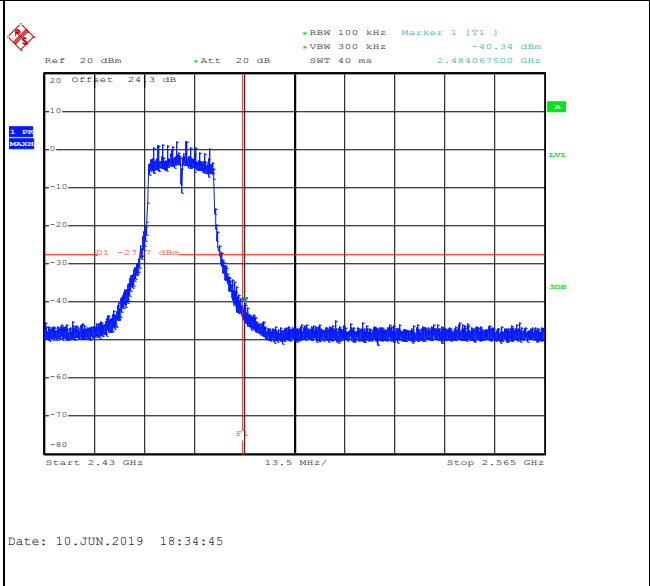
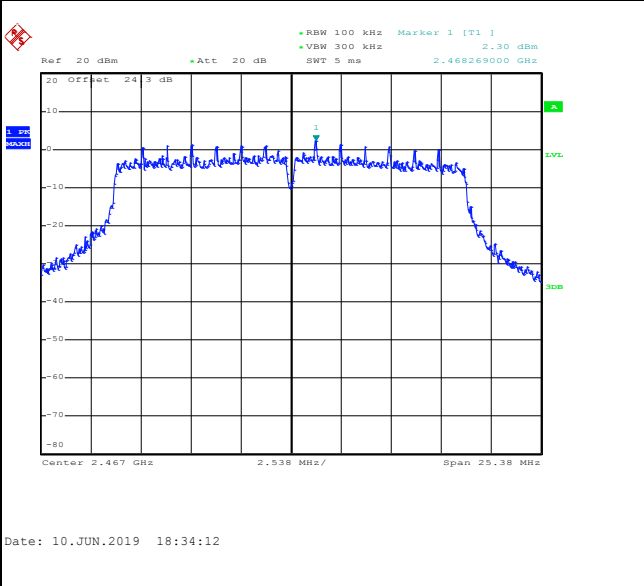

Spurious Emission 30MHz~3GHz	Spurious Emission 2GHz~25GHz
-------------------------------------	-------------------------------------

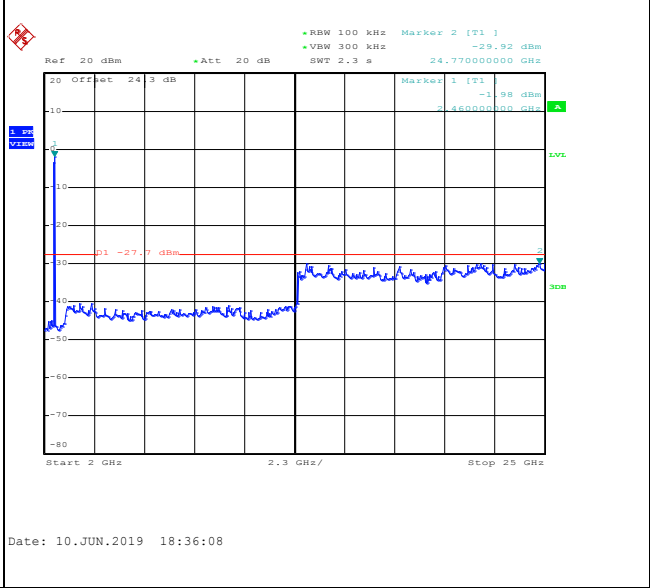
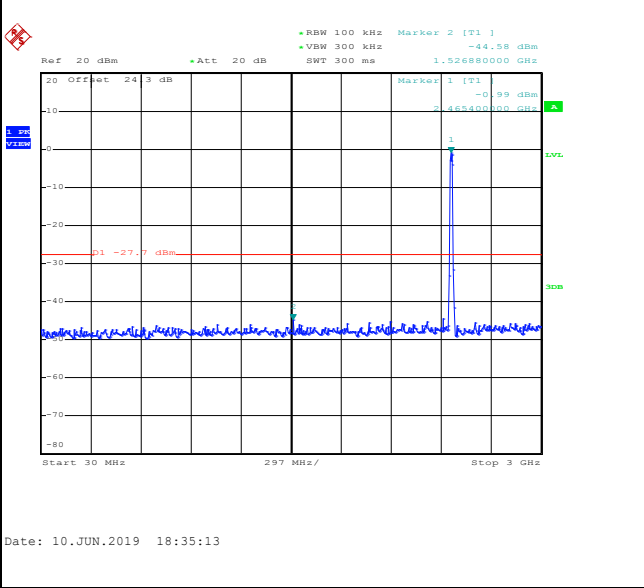



Test Mode :	802.11n HT20	Test Channel :	13
-------------	--------------	----------------	----

100kHz PSD reference Level	High Channel Plot
-----------------------------------	--------------------------

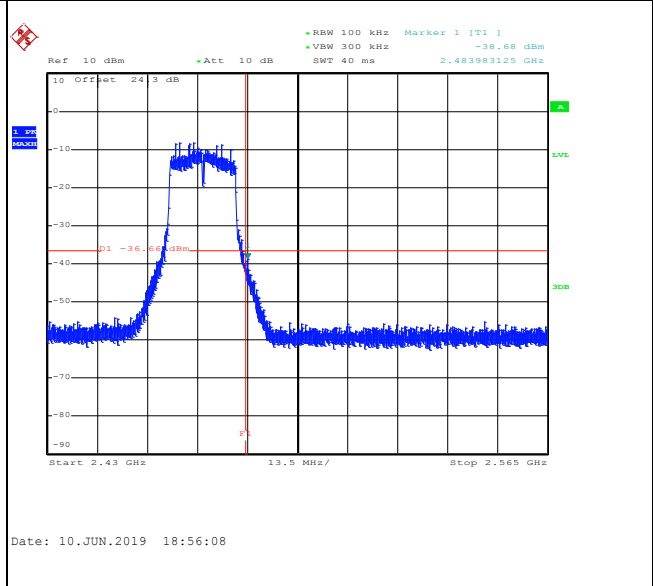
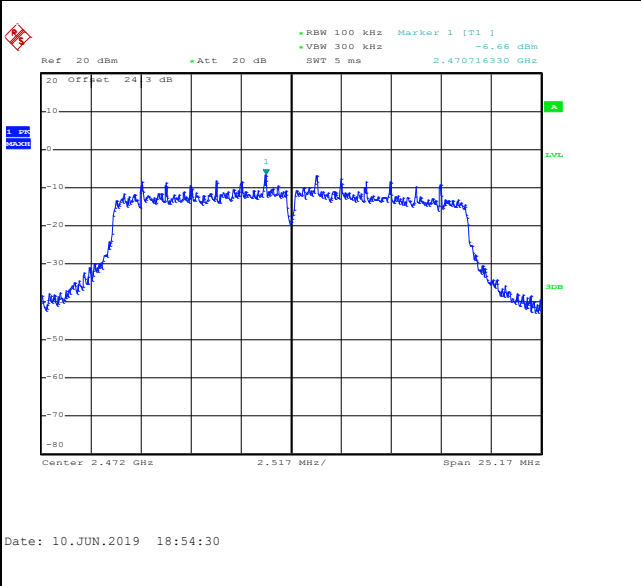

Spurious Emission 30MHz~3GHz	Spurious Emission 2GHz~25GHz
-------------------------------------	-------------------------------------

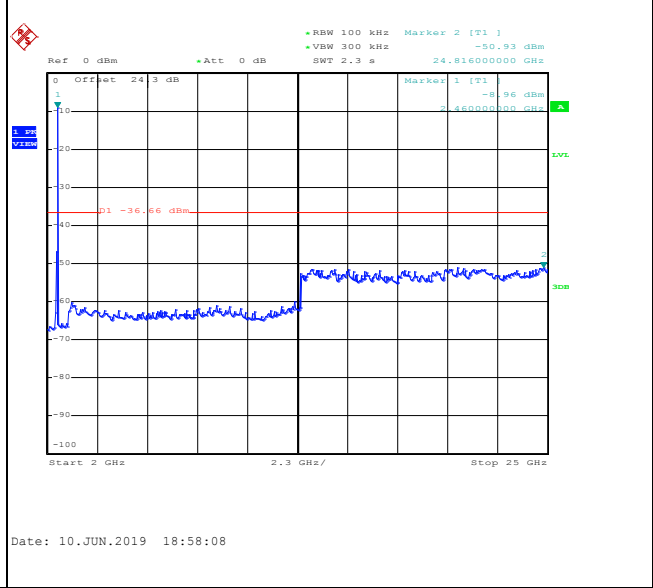
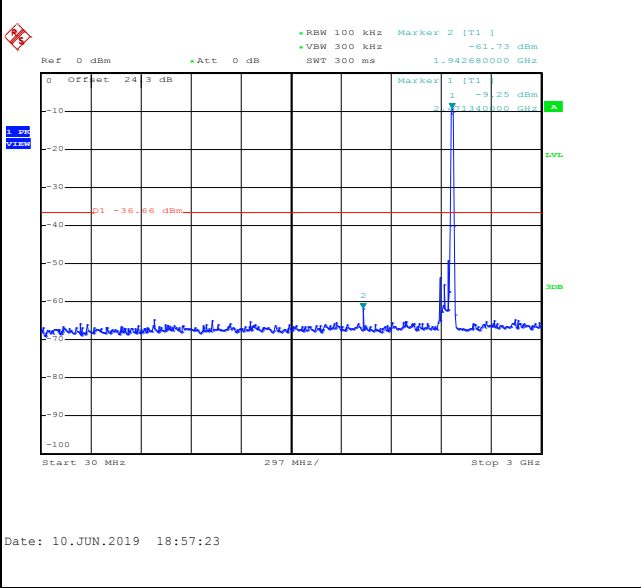



Number of TX = 2, Ant. 4 (Measured)

Test Mode :	802.11b	Test Channel :	01
-------------	---------	----------------	----

WLAN 802.11b Channel 01

100kHz PSD reference Level

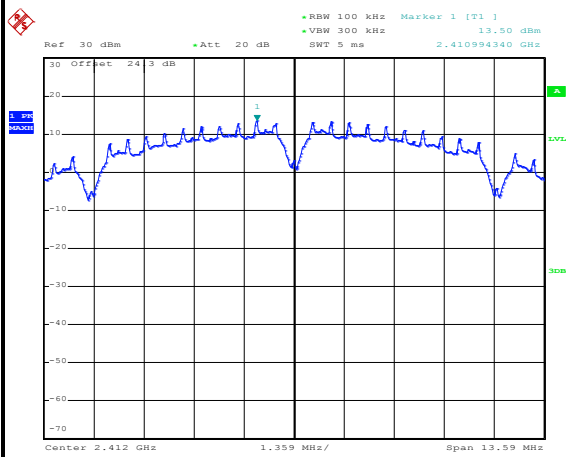

Date: 10.JUN.2019 09:43:24

Low Channel Plot

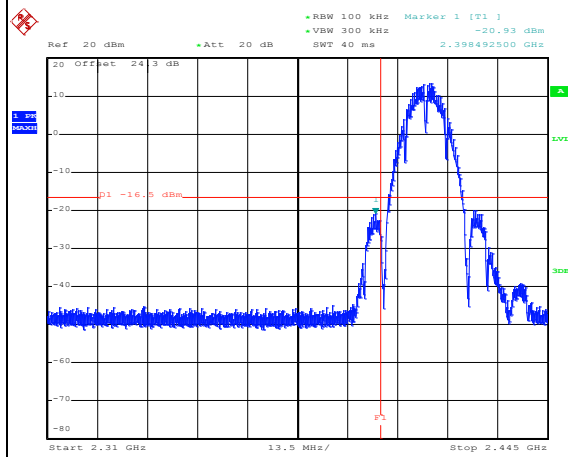

Date: 10.JUN.2019 09:44:11

Spurious Emission 30MHz~3GHz

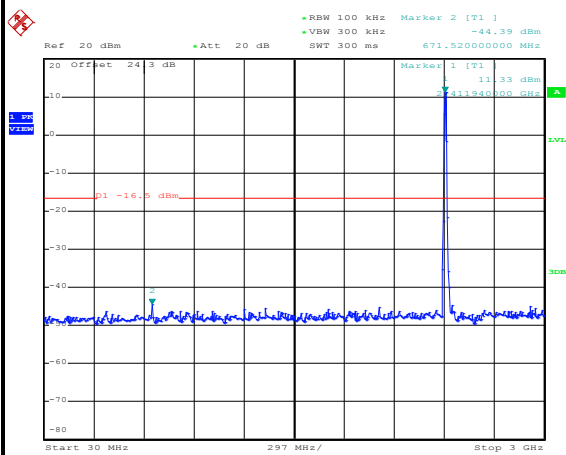

Date: 10.JUN.2019 09:44:49

Spurious Emission 2GHz~25GHz

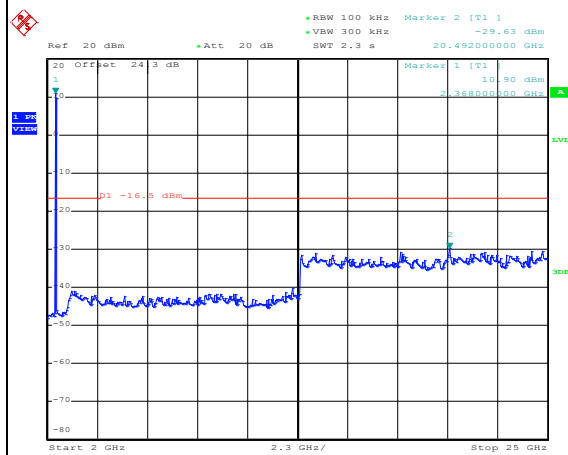

Date: 10.JUN.2019 09:45:20



Test Mode :	802.11b	Test Channel :	06
-------------	---------	----------------	----

100kHz PSD reference Level	Mid Channel Plot
-----------------------------------	-------------------------

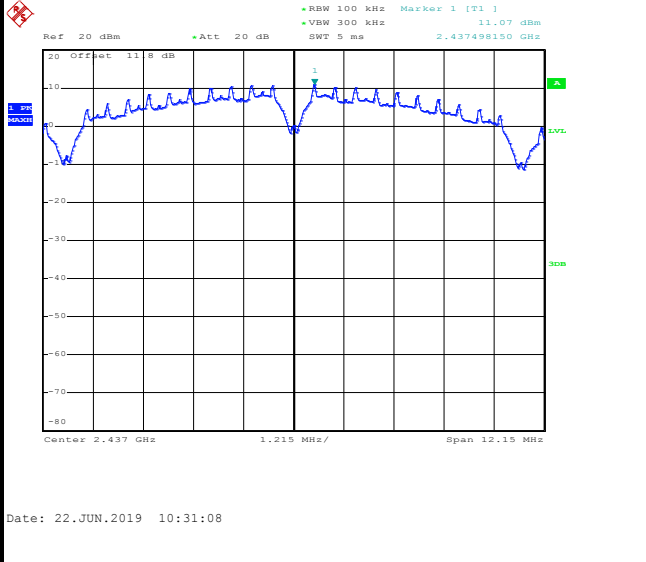

Spurious Emission 30MHz~3GHz	Spurious Emission 2GHz~25GHz
-------------------------------------	-------------------------------------

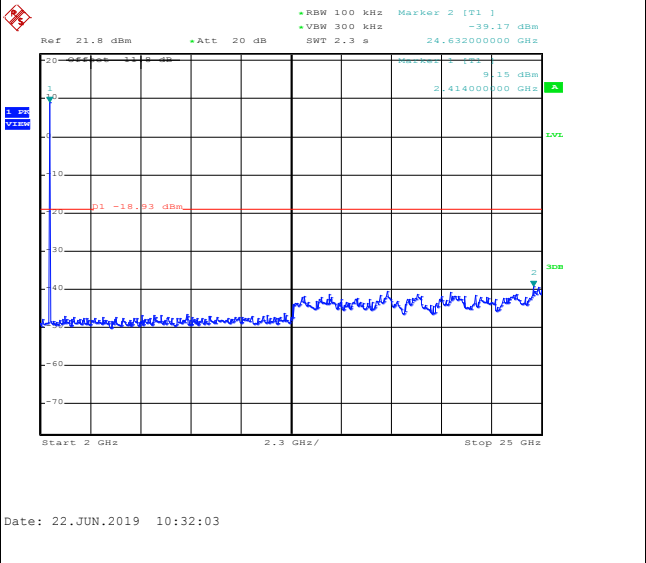
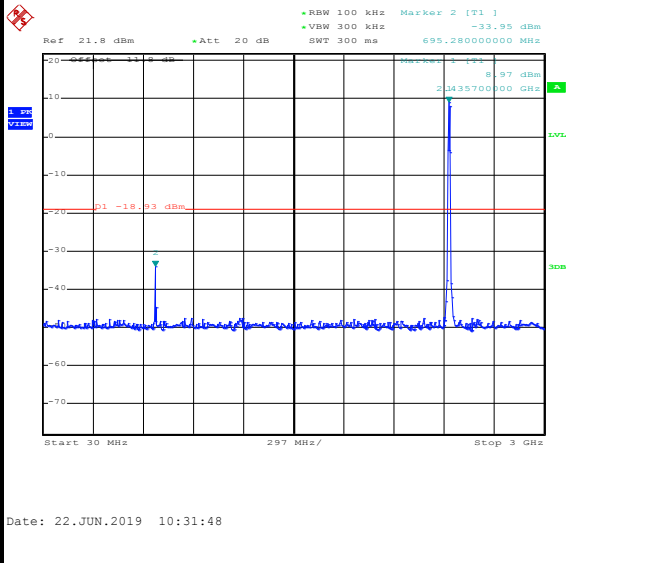



Test Mode :	802.11b	Test Channel :	11
-------------	---------	----------------	----

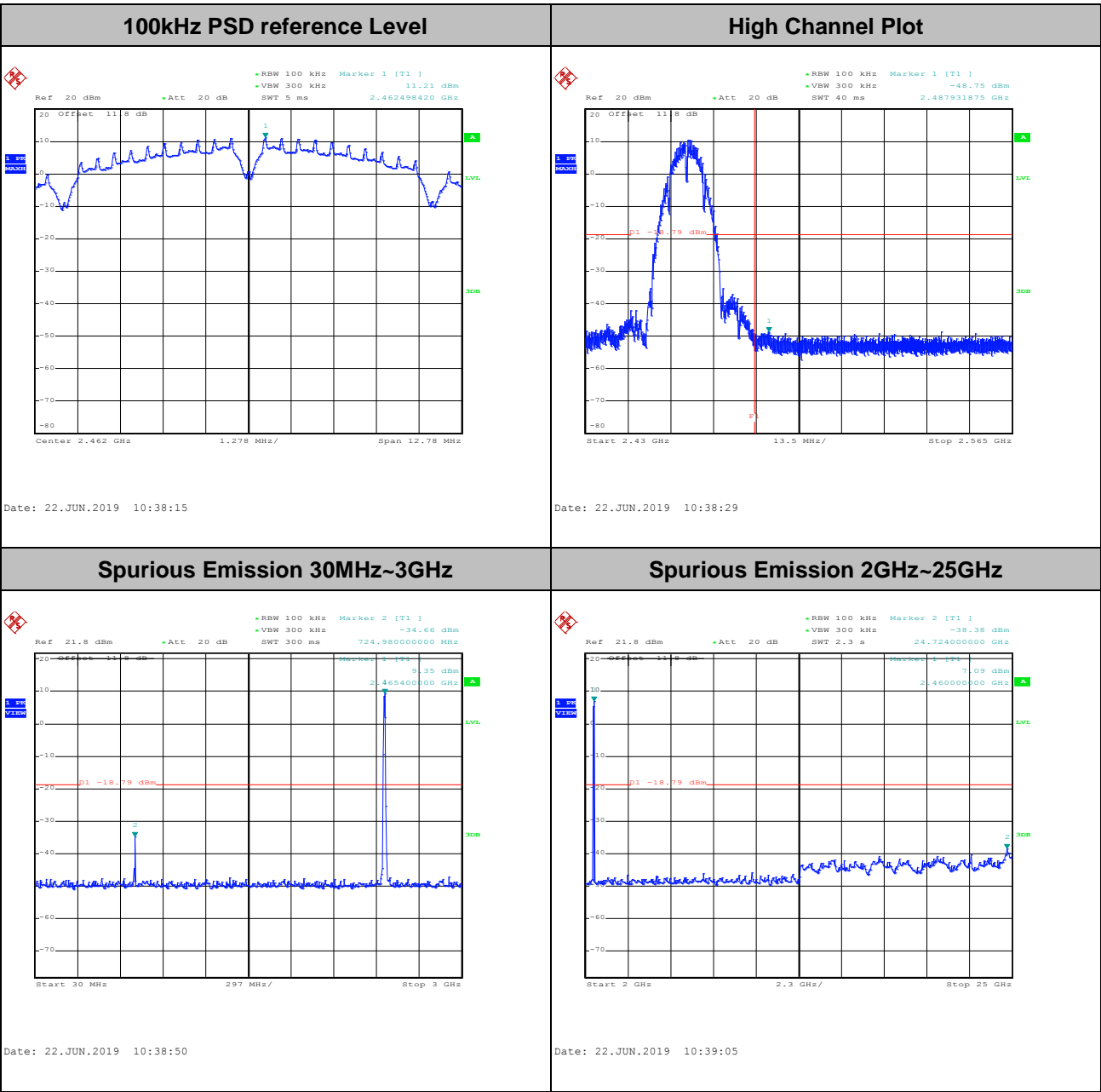



Test Mode :	802.11b	Test Channel :	12
-------------	---------	----------------	----

100kHz PSD reference Level	High Channel Plot
-----------------------------------	--------------------------

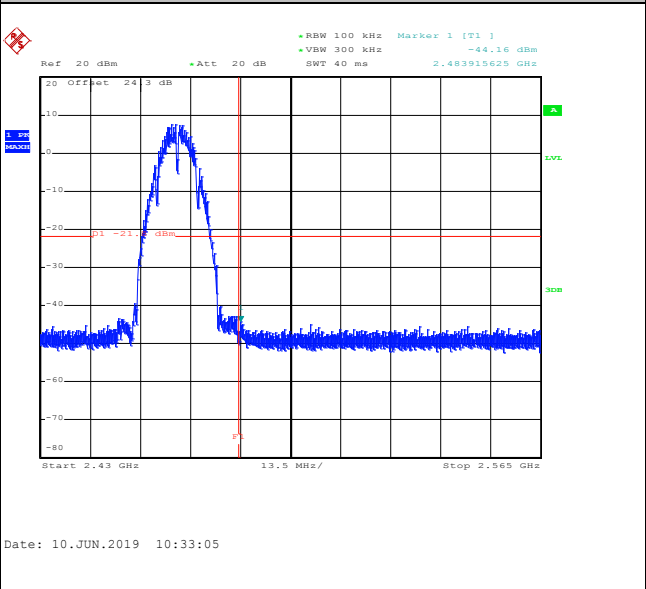
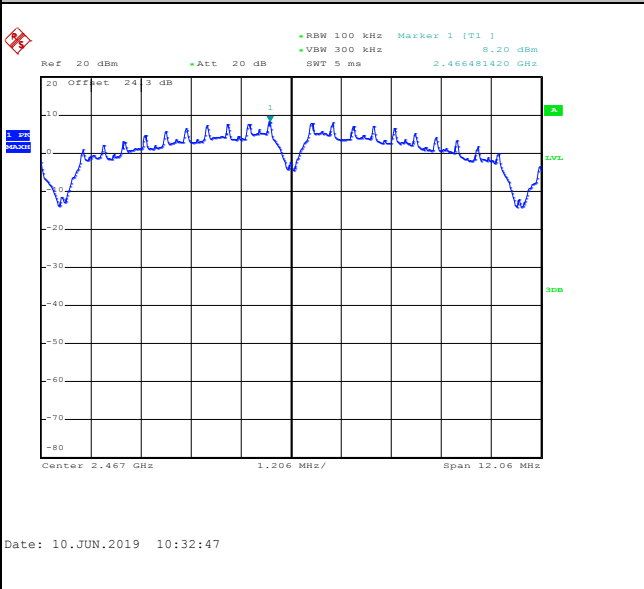

Spurious Emission 30MHz~3GHz	Spurious Emission 2GHz~25GHz
-------------------------------------	-------------------------------------

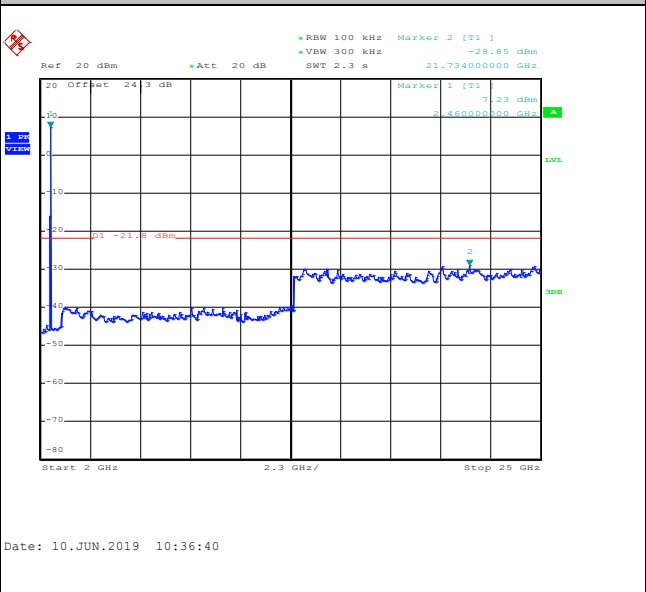
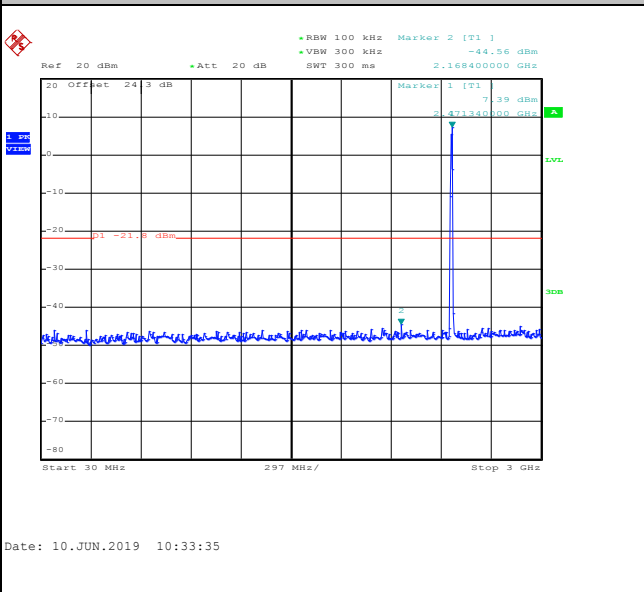



Test Mode :	802.11b	Test Channel :	13
-------------	---------	----------------	----

100kHz PSD reference Level	High Channel Plot
-----------------------------------	--------------------------

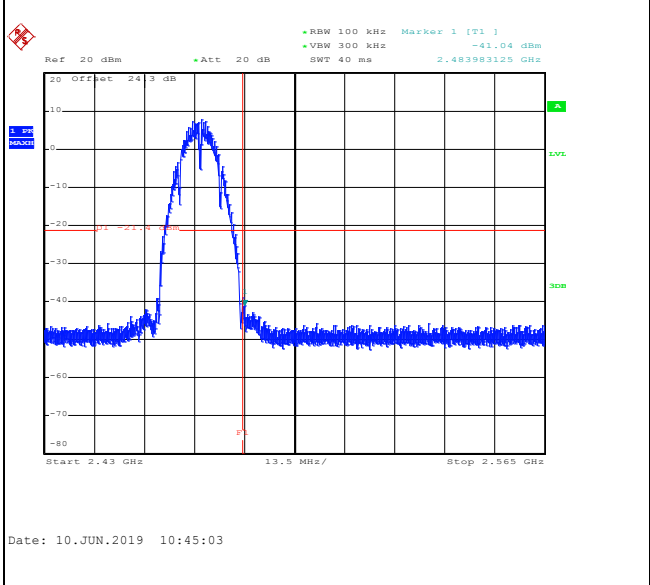
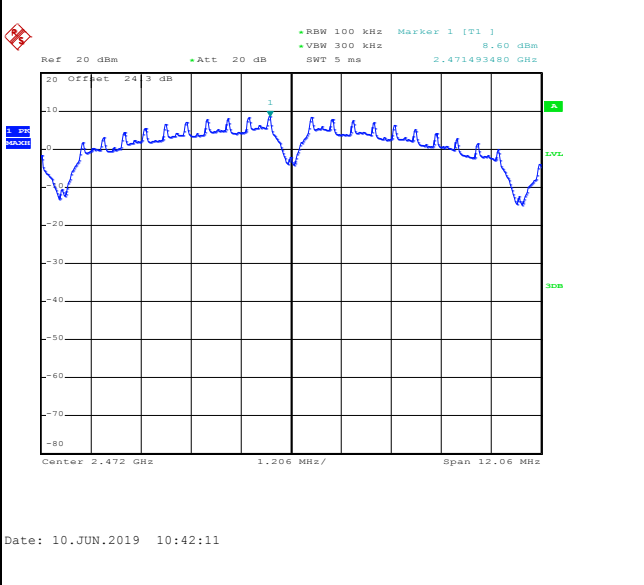

Spurious Emission 30MHz~3GHz	Spurious Emission 2GHz~25GHz
-------------------------------------	-------------------------------------

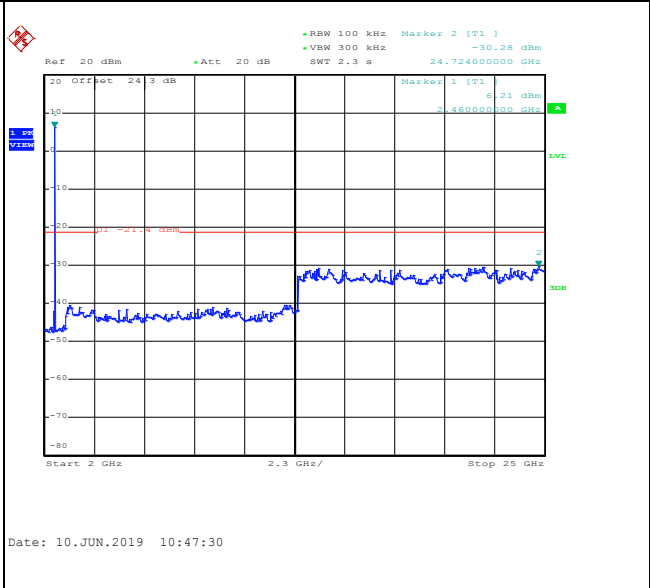
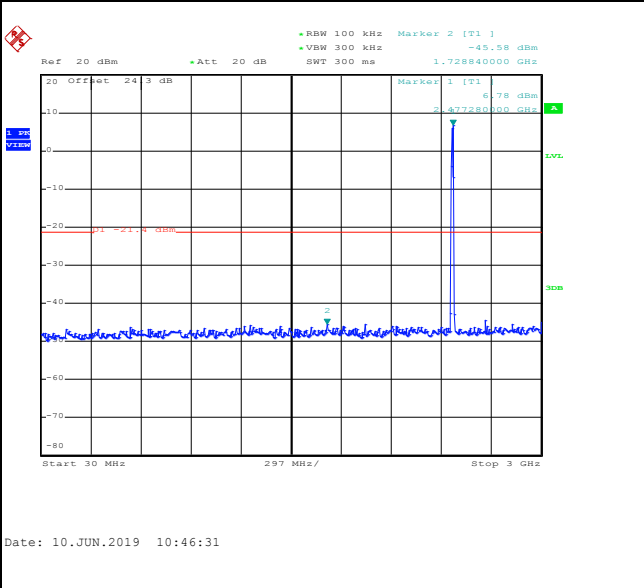



Test Mode :	802.11g	Test Channel :	01
-------------	---------	----------------	----

100kHz PSD reference Level	Low Channel Plot
-----------------------------------	-------------------------

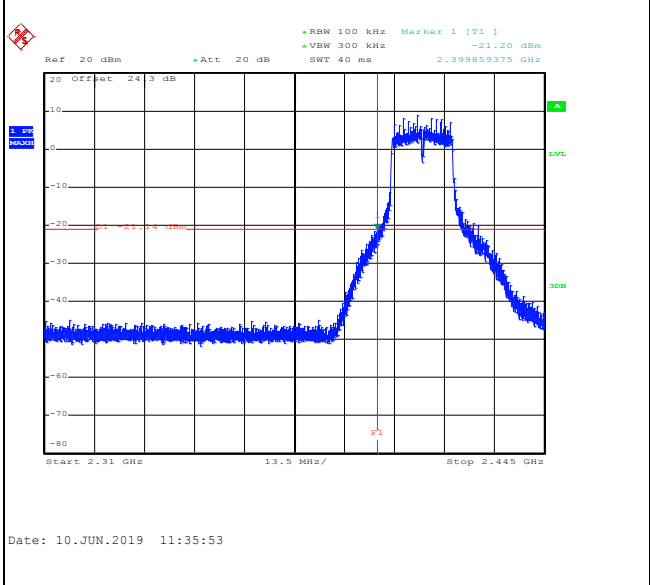
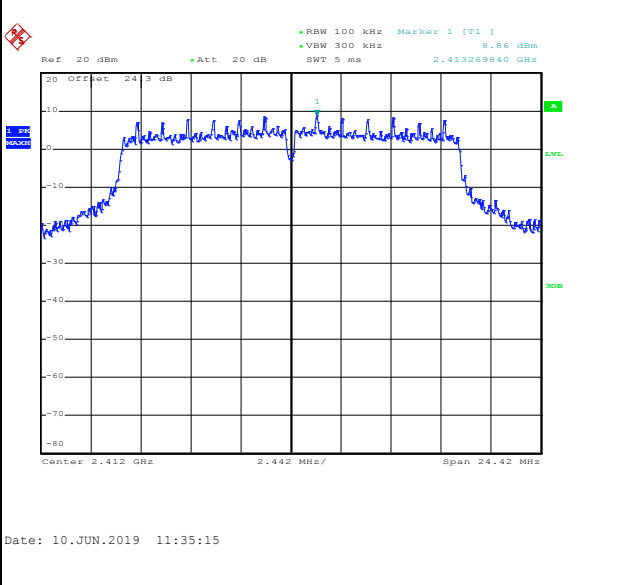

Spurious Emission 30MHz~3GHz	Spurious Emission 2GHz~25GHz
-------------------------------------	-------------------------------------

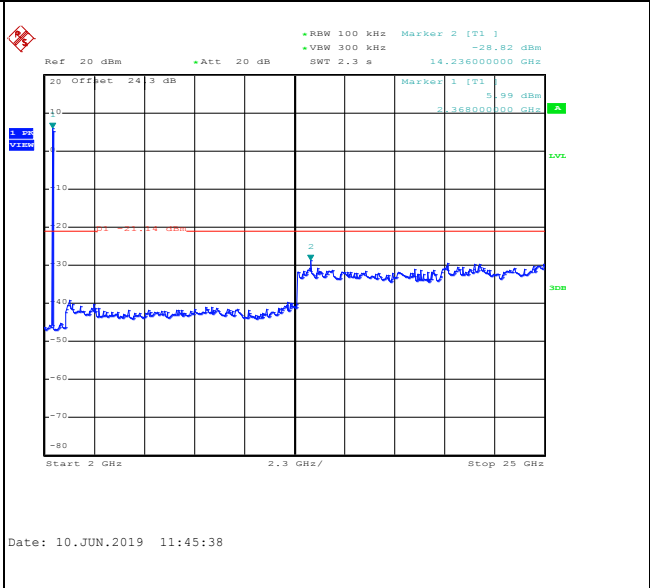
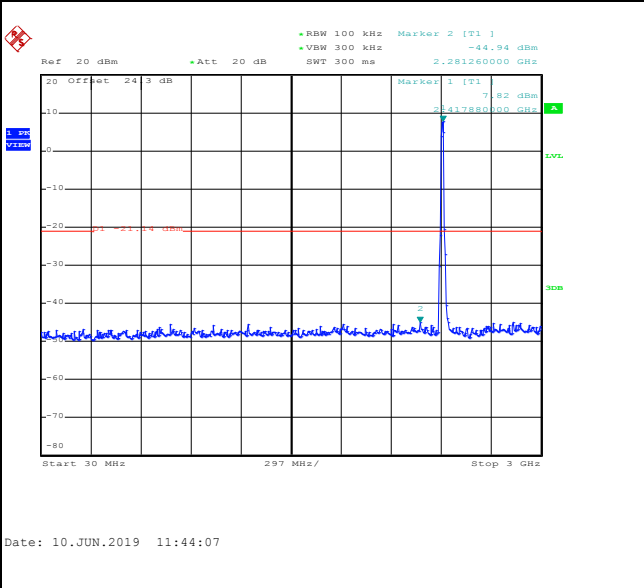



Test Mode :	802.11g	Test Channel :	06
-------------	---------	----------------	----

100kHz PSD reference Level	Mid Channel Plot
-----------------------------------	-------------------------

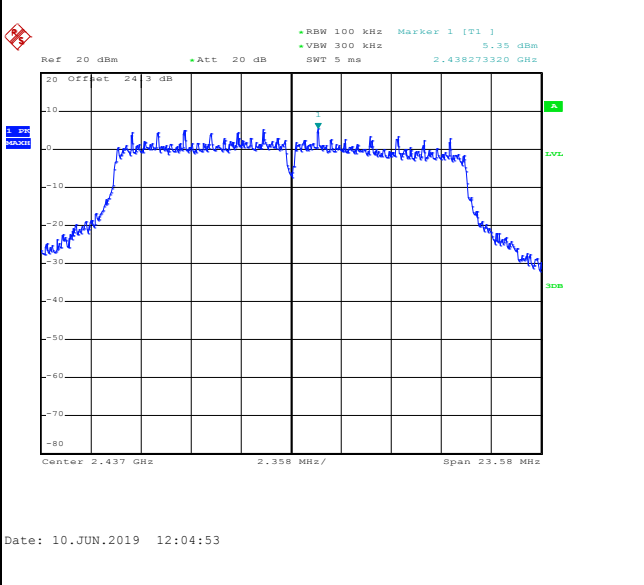

Spurious Emission 30MHz~3GHz	Spurious Emission 2GHz~25GHz
-------------------------------------	-------------------------------------

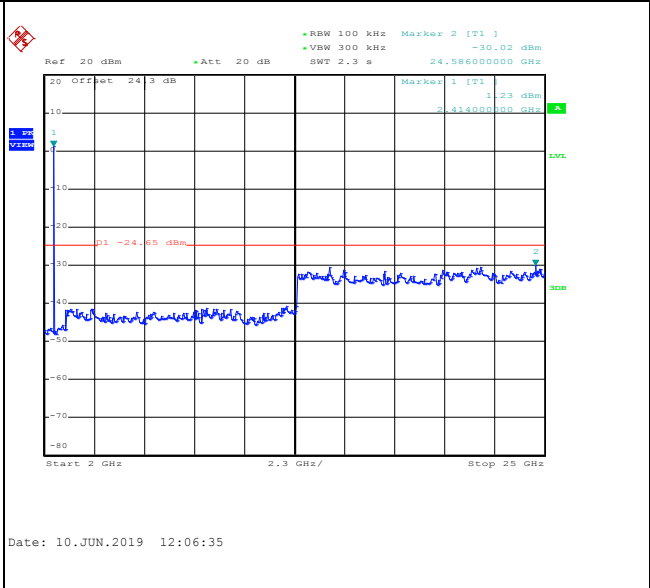
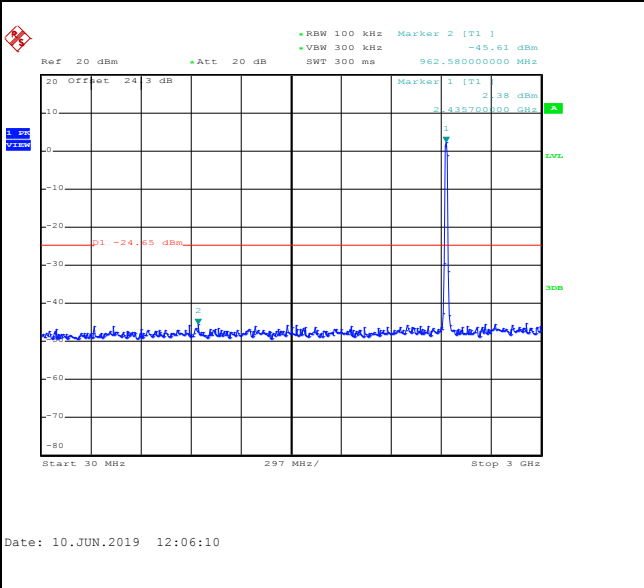



Test Mode :	802.11g	Test Channel :	11
-------------	---------	----------------	----

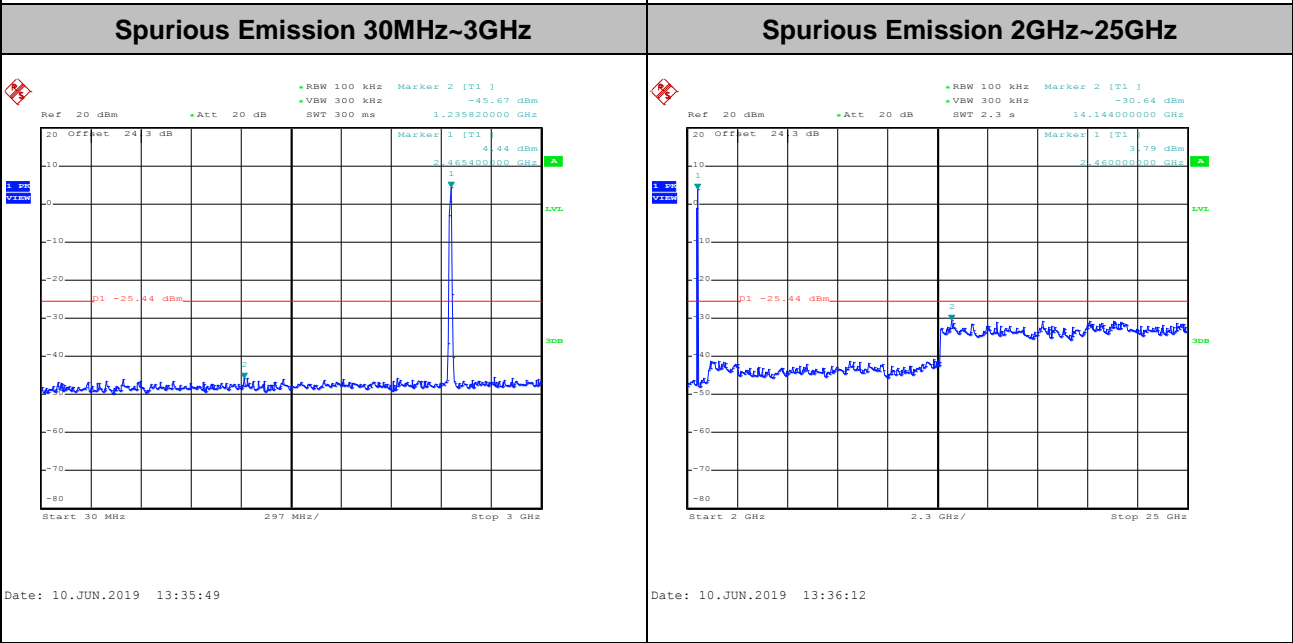
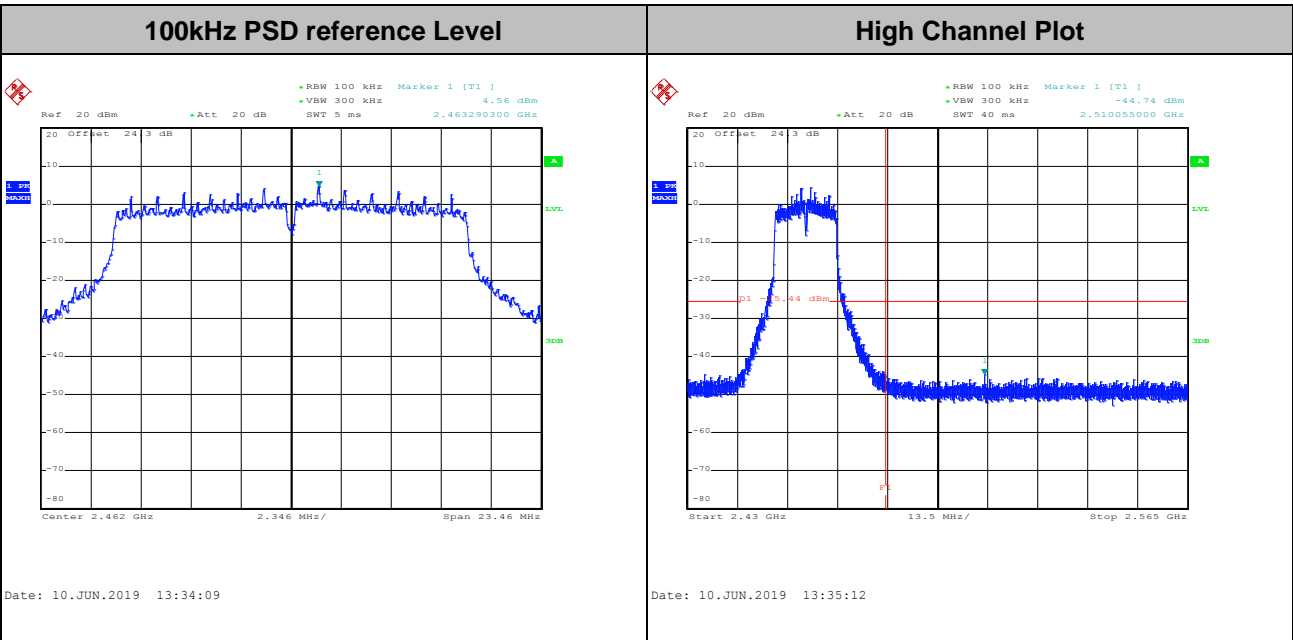



Test Mode :	802.11g	Test Channel :	12
-------------	---------	----------------	----

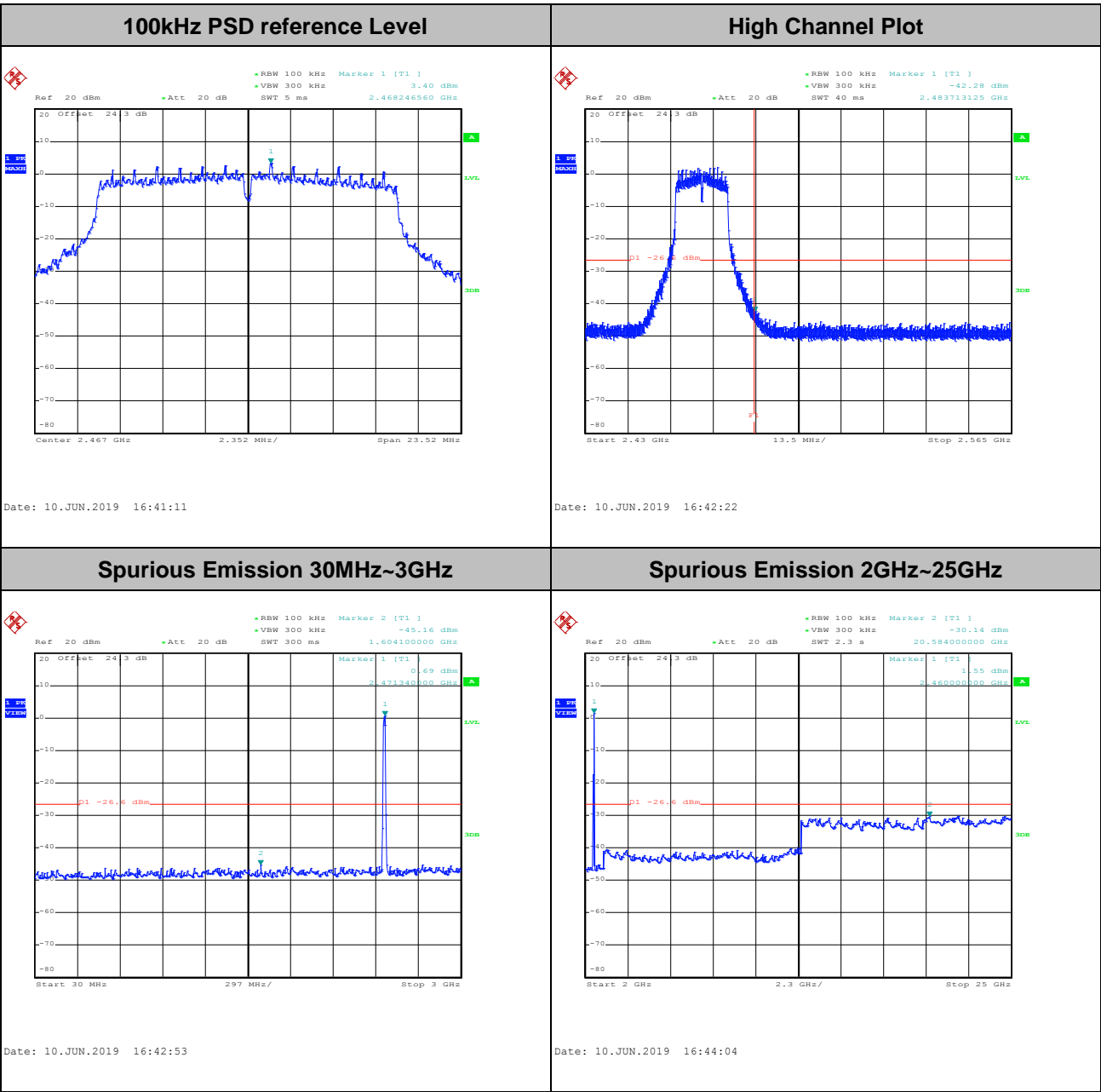



Test Mode :	802.11g	Test Channel :	13
-------------	---------	----------------	----

100kHz PSD reference Level	High Channel Plot
-----------------------------------	--------------------------

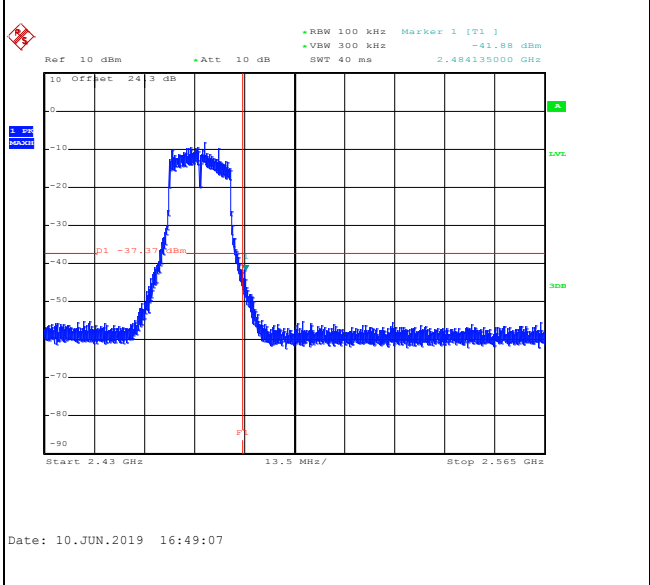
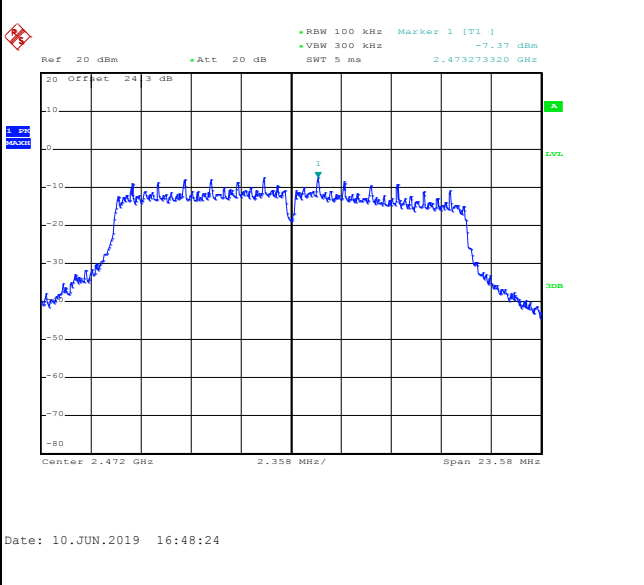

Spurious Emission 30MHz~3GHz	Spurious Emission 2GHz~25GHz
-------------------------------------	-------------------------------------

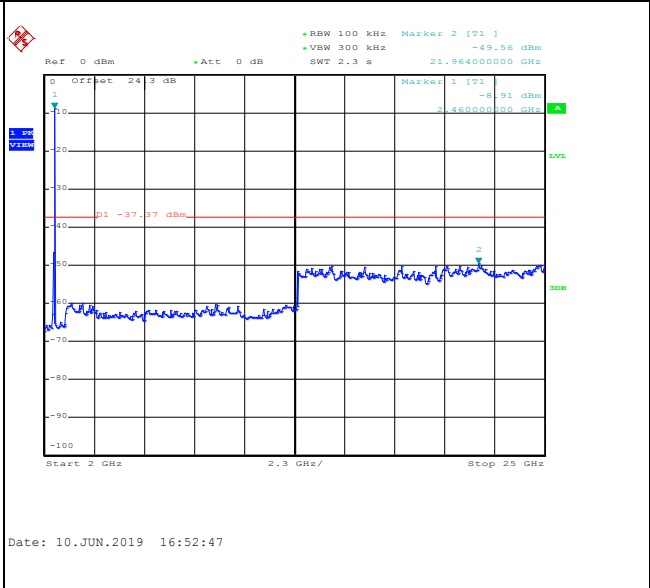
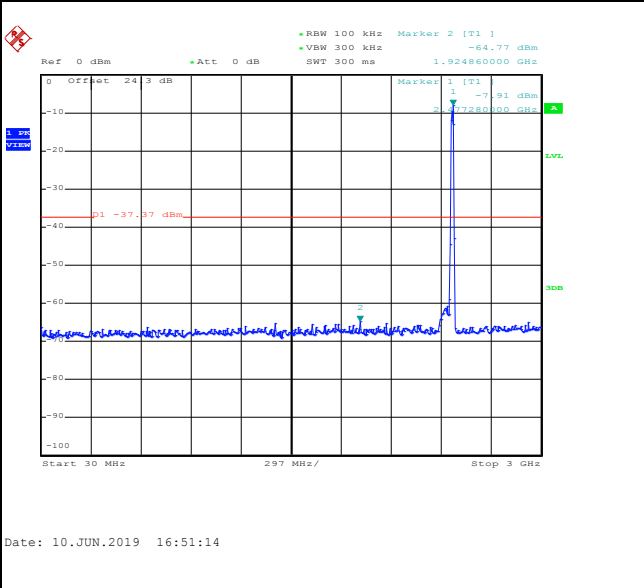



Test Mode :	802.11n HT20	Test Channel :	01
-------------	--------------	----------------	----

100kHz PSD reference Level	Low Channel Plot
-----------------------------------	-------------------------

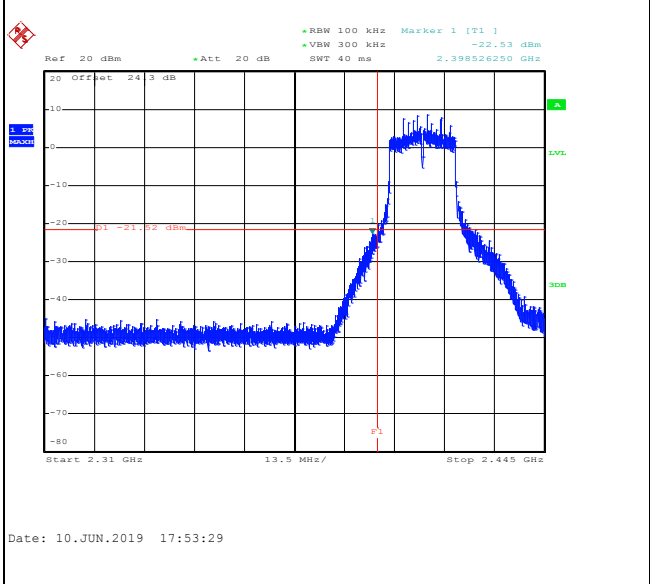
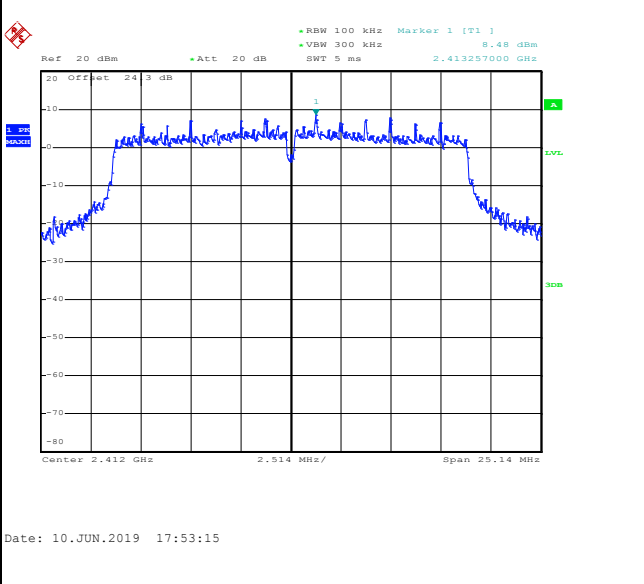

Spurious Emission 30MHz~3GHz	Spurious Emission 2GHz~25GHz
-------------------------------------	-------------------------------------

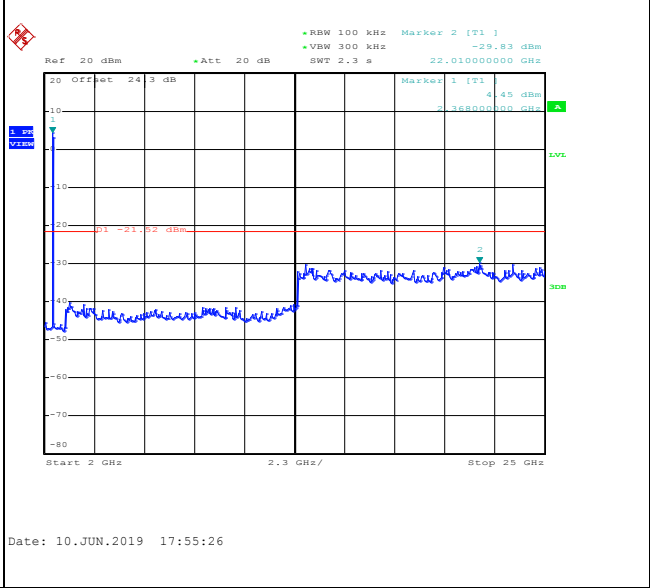
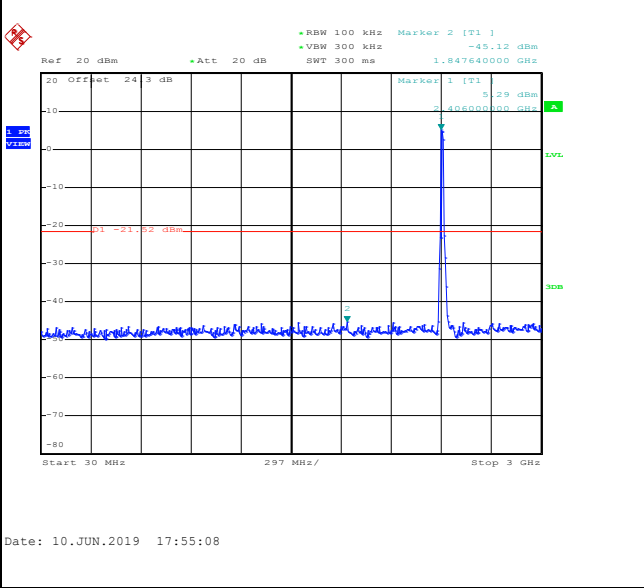



Test Mode :	802.11n HT20	Test Channel :	06
-------------	--------------	----------------	----

100kHz PSD reference Level	Mid Channel Plot
-----------------------------------	-------------------------

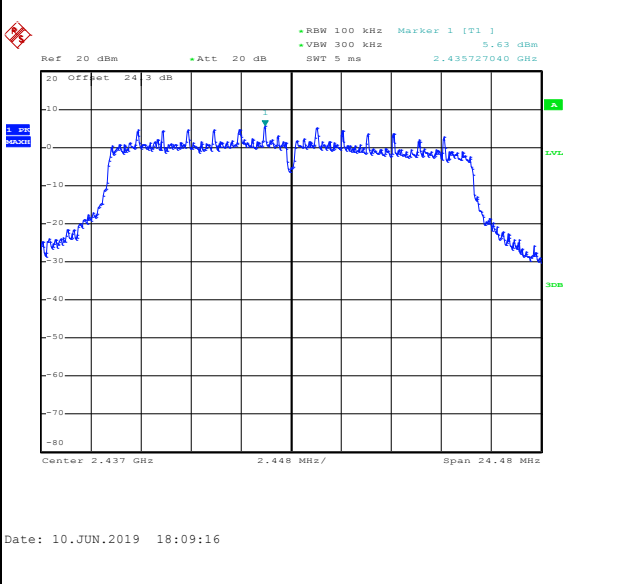

Spurious Emission 30MHz~3GHz	Spurious Emission 2GHz~25GHz
-------------------------------------	-------------------------------------

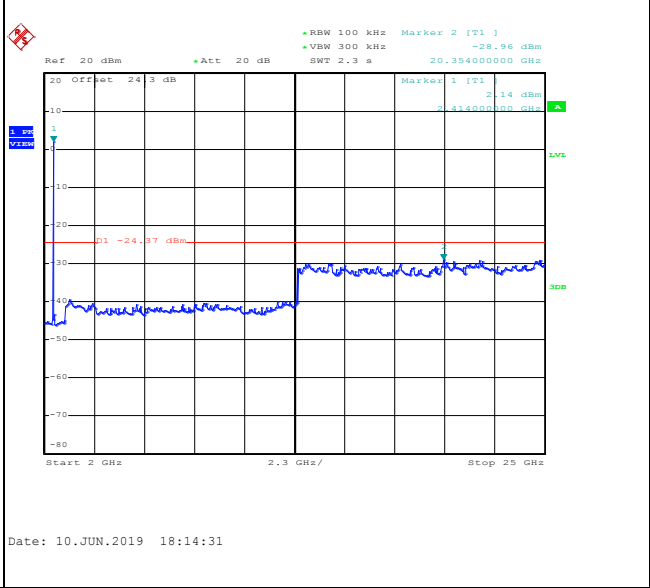
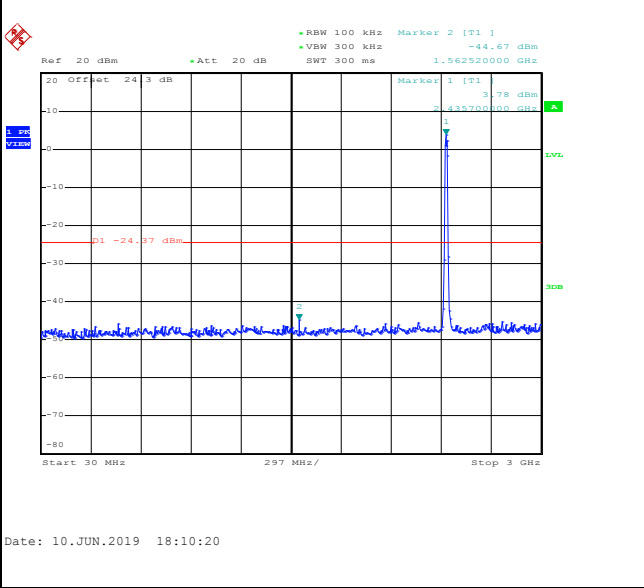



Test Mode :	802.11n HT20	Test Channel :	11
-------------	--------------	----------------	----

100kHz PSD reference Level	High Channel Plot
-----------------------------------	--------------------------

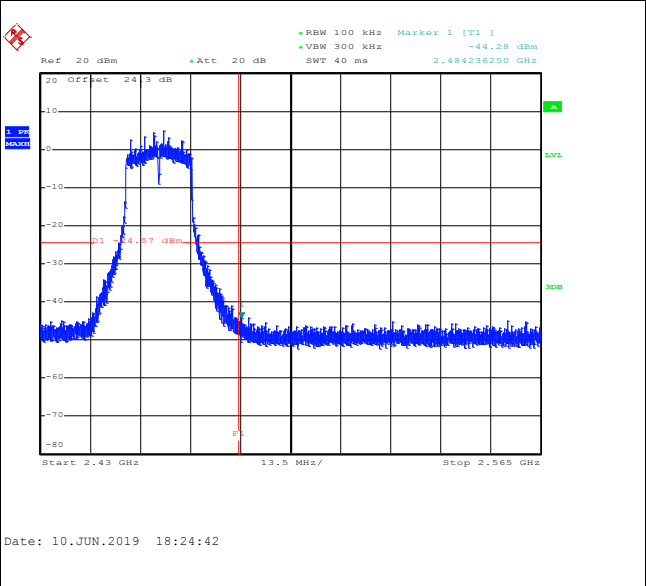
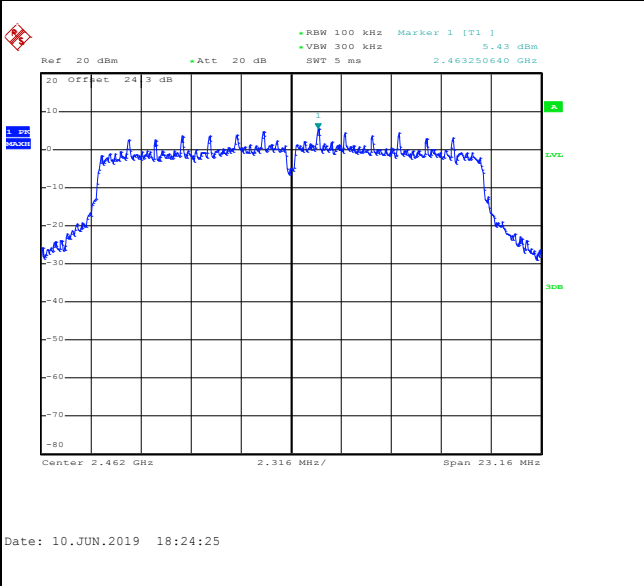

Spurious Emission 30MHz~3GHz	Spurious Emission 2GHz~25GHz
-------------------------------------	-------------------------------------

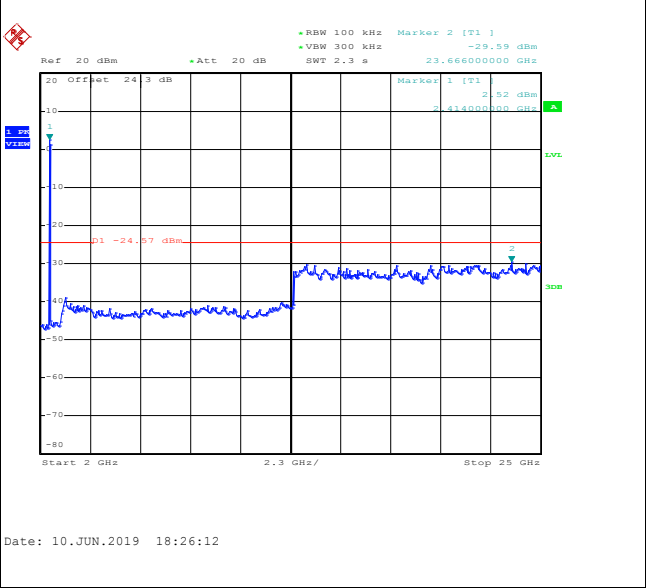
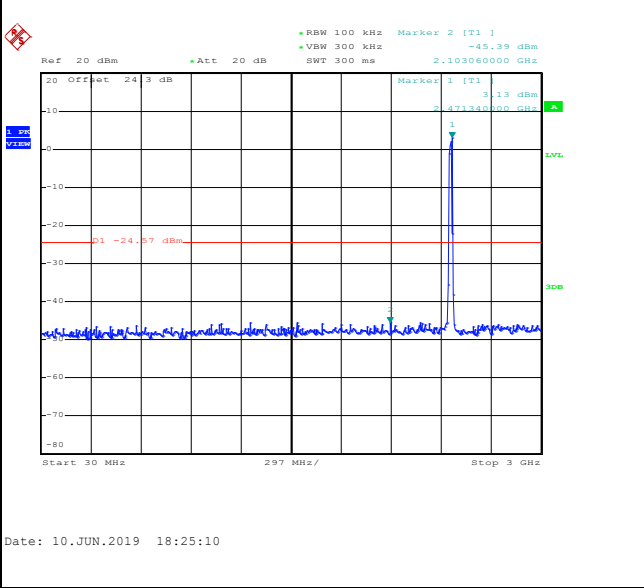



Test Mode :	802.11n HT20	Test Channel :	12
-------------	--------------	----------------	----

100kHz PSD reference Level	High Channel Plot
-----------------------------------	--------------------------

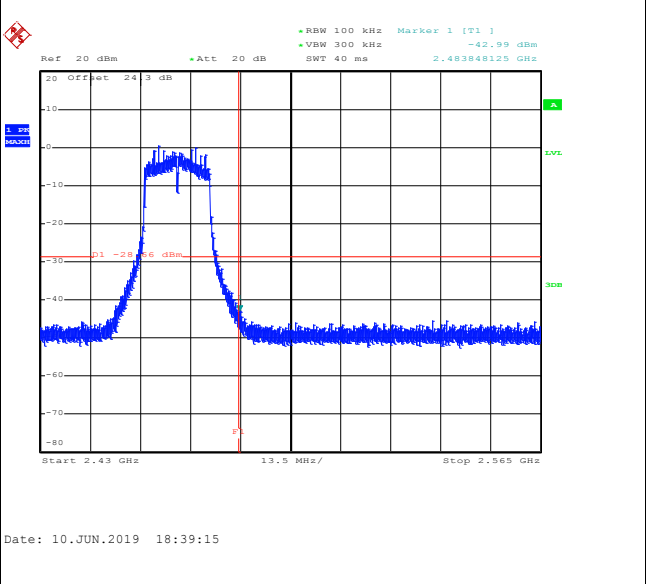
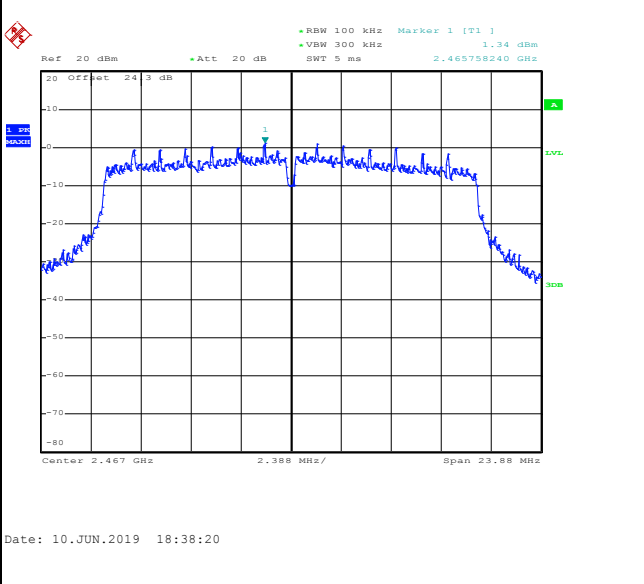

Spurious Emission 30MHz~3GHz	Spurious Emission 2GHz~25GHz
-------------------------------------	-------------------------------------

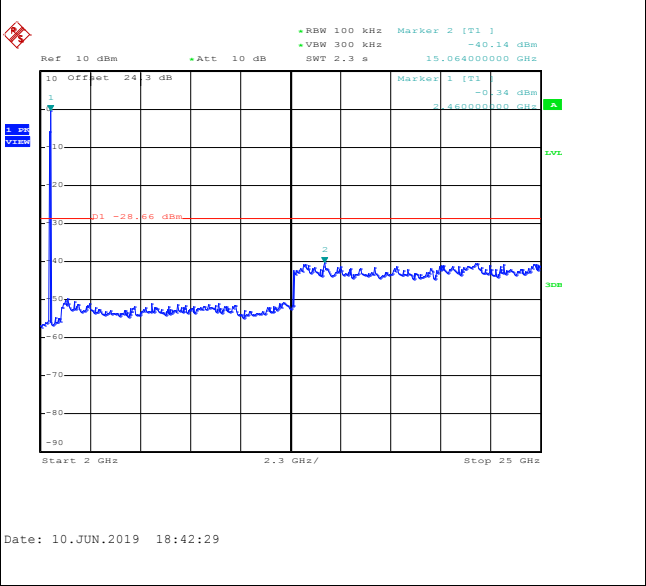
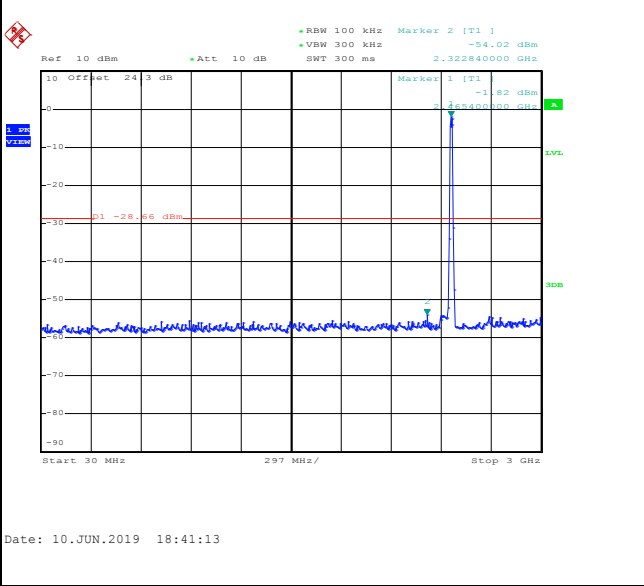



Test Mode :	802.11n HT20	Test Channel :	13
-------------	--------------	----------------	----

100kHz PSD reference Level	High Channel Plot
-----------------------------------	--------------------------

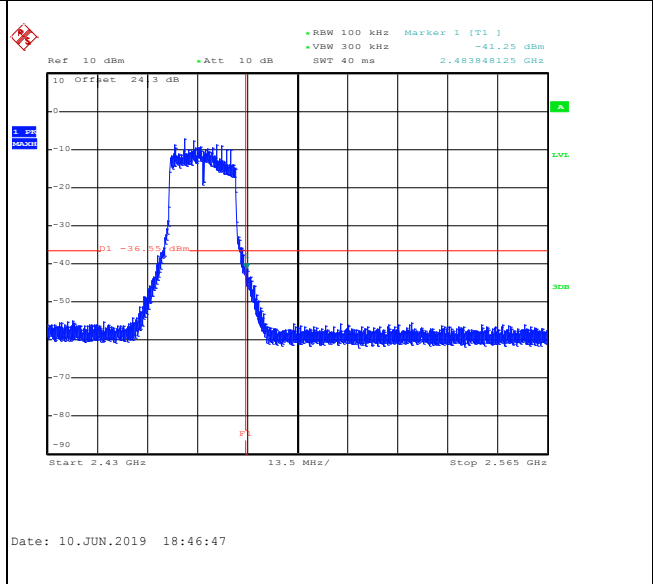
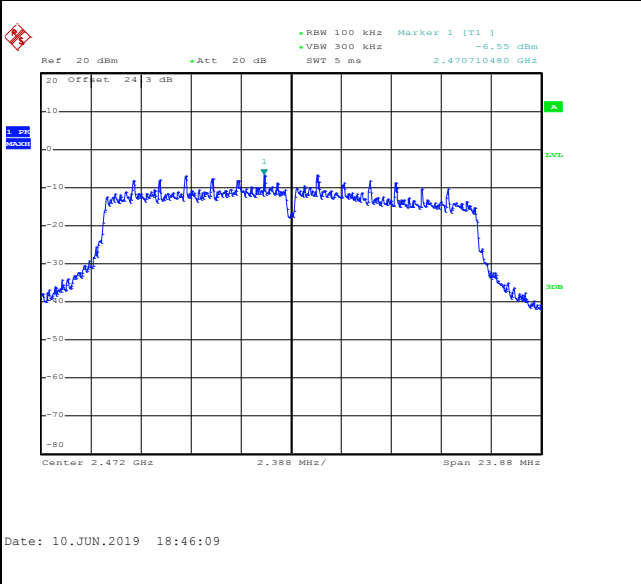

Spurious Emission 30MHz~3GHz	Spurious Emission 2GHz~25GHz
-------------------------------------	-------------------------------------

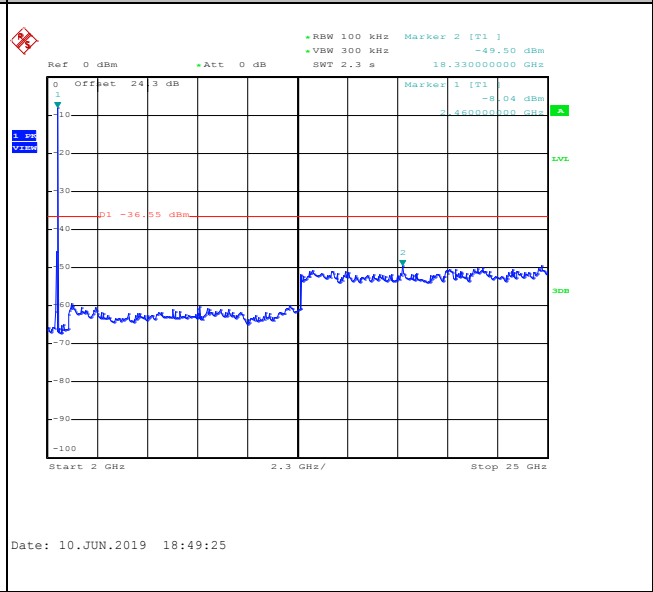
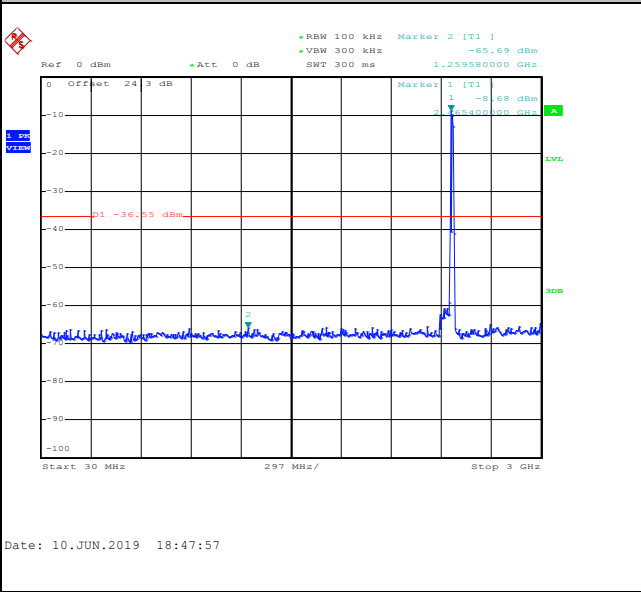



3.5 Radiated Band Edges and Spurious Emission Measurement

3.5.1 Limit of Radiated band edge and Spurious Emission Measurement

In any 100 kHz bandwidth outside the intentional radiator frequency band, all harmonics/spurious must be at least 20 dB below the highest emission level within the authorized band. If the output power of this device was measured by spectrum analyzer, the attenuation under this paragraph shall be 30 dB instead of 20 dB. In addition, radiated emissions which fall in the restricted bands must also comply with the limits as below.

Frequency (MHz)	Field Strength (microvolts/meter)	Measurement Distance (meters)
0.009 – 0.490	2400/F(kHz)	300
0.490 – 1.705	24000/F(kHz)	30
1.705 – 30.0	30	30
30 – 88	100	3
88 – 216	150	3
216 - 960	200	3
Above 960	500	3

3.5.2 Measuring Instruments

See list of measuring equipment of this test report.



3.5.3 Test Procedures

1. The testing follows the ANSI C63.10 Section 11.12.1 Radiated emission measurements.
2. The EUT was arranged to its worst case and then tune the antenna tower (from 1 m to 4 m) and turntable (from 0 degree to 360 degrees) to find the maximum reading. A pre-amp and a high pass filter are used for the test in order to get better signal level.
3. The EUT was placed on a turntable with 0.8 meter for frequency below 1GHz and 1.5 meter for frequency above 1GHz respectively above ground.
4. The EUT was set 3 meters from the interference receiving antenna, which was mounted on the top of a variable height antenna tower.
5. Corrected Reading: Antenna Factor + Cable Loss + Read Level - Preamp Factor = Level
6. For testing below 1GHz, if the emission level of the EUT in peak mode was 3 dB lower than the limit specified, then peak values of EUT will be reported, otherwise, the emissions will be repeated one by one using the CISPR quasi-peak method and reported.
7. For testing above 1GHz, the emission level of the EUT in peak mode was 20dB lower than average limit (that means the emission level in average mode also complies with the limit in average mode), then peak values of EUT will be reported, otherwise, the emissions will be measured in average mode again and reported.
8. Use the following spectrum analyzer settings:
 - (1) Span shall wide enough to fully capture the emission being measured;
 - (2) Set RBW=100 kHz for $f < 1$ GHz; $VBW \geq RBW$; Sweep = auto; Detector function = peak; Trace = max hold;
 - (3) Set RBW = 1 MHz, VBW= 3MHz for $f \geq 1$ GHz for peak measurement.
For average measurement:
 - $VBW = 10$ Hz, when duty cycle is no less than 98 percent.
 - $VBW \geq 1/T$, when duty cycle is less than 98 percent where T is the minimum transmission duration over which the transmitter is on and is transmitting at its maximum power control level for the tested mode of operation.

3.5.4 Test Setup

For radiated emissions below 30MHz

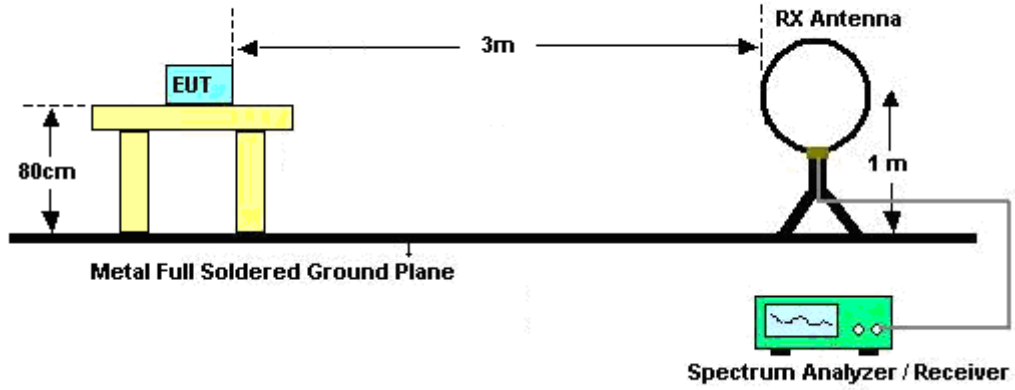

For radiated emissions from 30MHz to 1GHz

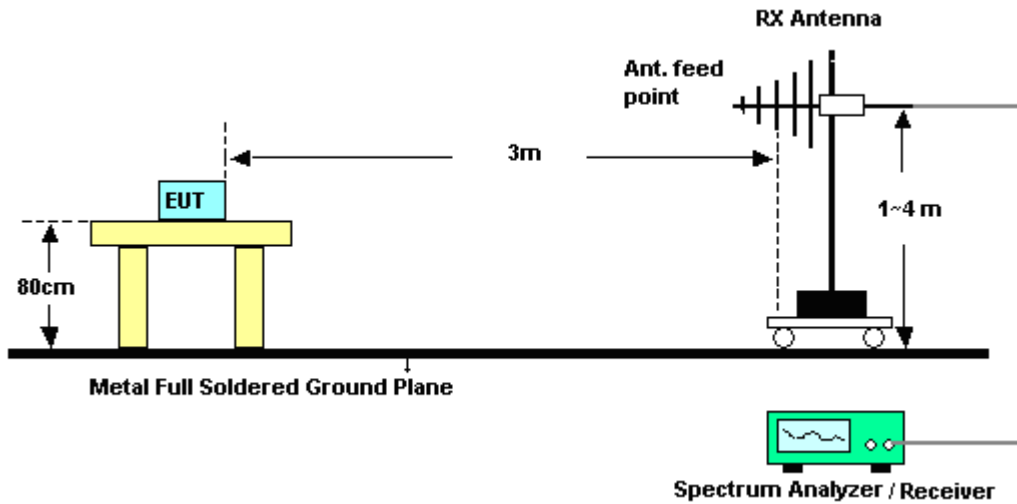

For radiated emissions above 1GHz

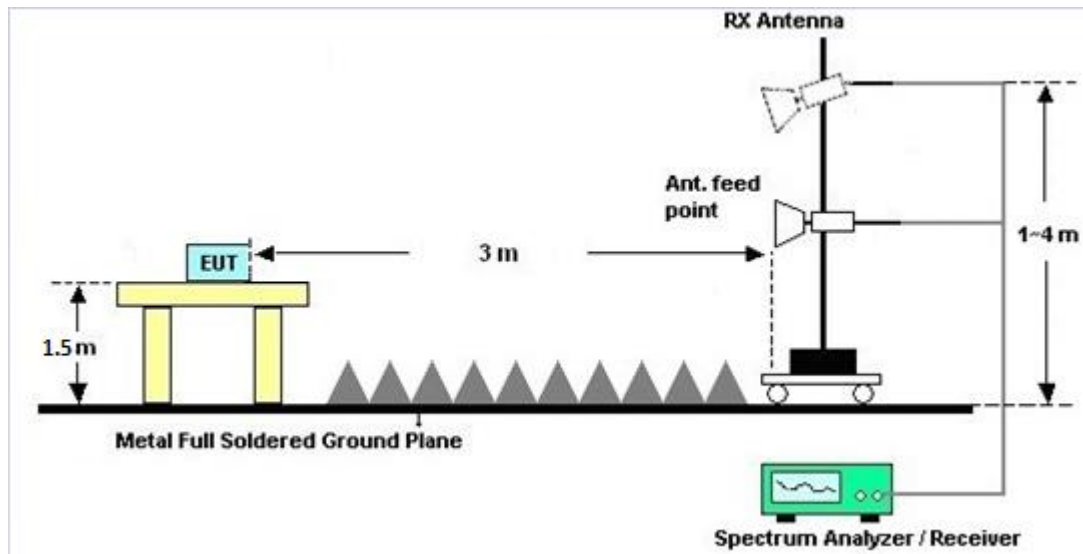

3.5.5 Test Results of Radiated Spurious Emissions (9kHz ~ 30MHz)

The low frequency, which started from 9 kHz to 30MHz, was pre-scanned and the result which was 20dB lower than the limit line was not reported.

There is a comparison data of both open-field test site and alternative test site - semi-Anechoic chamber according to 414788 D01 Radiated Test Site v01r01, and the result came out very similar.

3.5.6 Test Result of Radiated Spurious at Band Edges

Please refer to Appendix C and D.

3.5.7 Duty Cycle

Please refer to Appendix E.

3.5.8 Test Result of Radiated Spurious Emission (30MHz ~ 10th Harmonic)

Please refer to Appendix C and D.



3.6 AC Conducted Emission Measurement

3.6.1 Limit of AC Conducted Emission

For equipment that is designed to be connected to the public utility (AC) power line, the radio frequency voltage that is conducted back onto the AC power line on any frequency or frequencies within the band 150 kHz to 30 MHz shall not exceed the limits in the following table.

Frequency of Emission (MHz)	Conducted Limit (dB μ V)	
	Quasi-Peak	Average
0.15-0.5	66 to 56*	56 to 46*
0.5-5	56	46
5-30	60	50

*Decreases with the logarithm of the frequency.

3.6.2 Measuring Instruments

See list of measuring equipment of this test report.

3.6.3 Test Procedures

1. The EUT was placed 0.4 meter from the conducting wall of the shielding room, and it was kept at least 80 centimeters from any other grounded conducting surface.
2. Connect EUT to the power mains through a line impedance stabilization network (LISN).
3. All the support units are connecting to the other LISN.
4. The LISN provides 50 ohm coupling impedance for the measuring instrument.
5. The FCC states that a 50 ohm, 50 microhenry LISN should be used.
6. Both sides of AC line were checked for maximum conducted interference.
7. The frequency range from 150 kHz to 30 MHz was searched.
8. Set the test-receiver system to Peak Detect Function and specified bandwidth (IF bandwidth = 9kHz) with Maximum Hold Mode.

3.6.4 Test Setup



3.6.5 Test Result of AC Conducted Emission

Please refer to Appendix B.



3.7 Antenna Requirements

3.7.1 Standard Applicable

If directional gain of transmitting Antennas is greater than 6dBi, the power shall be reduced by the same level in dB comparing to gain minus 6dBi. The use of a permanently attached Antenna or of an Antenna that uses a unique coupling to the intentional radiator shall be considered sufficient to comply with the rule.

3.7.2 Antenna Anti-Replacement Construction

An embedded-in antenna design is used.

3.7.3 Antenna Gain

<CDD Modes >

FCC KDB 662911 D01 Multiple Transmitter Output v02r01

For CDD transmissions, directional gain is calculated as

Directional gain = G_{ANT} + Array Gain, where Array Gain is as follows.

For power spectral density (PSD) measurements on all devices,

Array Gain = $10 \log(N_{ANT}/N_{SS}=1)$ dB.

For power measurements on IEEE 802.11 devices,

Array Gain = 0 dB (i.e., no array gain) for $N_{ANT} \leq 4$.

Directional gain may be calculated by using the formulas applicable to equal gain antennas with G_{ANT} set equal to the gain of the antenna having the highest gain;

The EUT supports CDD mode.

For power, the directional gain G_{ANT} is set equal to the antenna having the highest gain, i.e., F)2)f)i).

For PSD, the directional gain calculation is following F)2)f)ii) of KDB 662911 D01 v02r01.

The power and PSD limit should be modified if the directional gain of EUT is over 6 dBi,

The directional gain "DG" is calculated as following table.

<CDD Modes>						
			DG	DG	Power	PSD
			for	for	Limit	Limit
	Ant. 2	Ant. 4	Power	PSD	Reduction	Reduction
	(dBi)	(dBi)	(dBi)	(dBi)	(dB)	(dB)
2.4 GHz	-0.50	-2.90	-0.50	1.39	0.00	0.00

$Power\ Limit\ Reduction = DG(Power) - 6dBi, (min = 0)$

$PSD\ Limit\ Reduction = DG(PSD) - 6dBi, (min = 0)$



4 List of Measuring Equipment

Instrument	Manufacturer	Model No.	Serial No.	Characteristics	Calibration Date	Test Date	Due Date	Remark
Power Sensor	DARE	RPR3006W	13I00030SNO 32	9kHz~6GHz	Dec. 03, 2018	Apr. 10, 2019 ~ Jun. 22, 2019	Dec. 02, 2019	Conducted (TH05-HY)
Spectrum Analyzer	Rohde & Schwarz	FSP40	100057	9kHz-40GHz	Nov. 21, 2018	Apr. 10, 2019 ~ Jun. 22, 2019	Nov. 20, 2019	Conducted (TH05-HY)
Switch Box & RF Cable	Burgeon	ETF-058	EC1208382	N/A	Mar. 27, 2019	Apr. 10, 2019 ~ Jun. 22, 2019	Mar. 26, 2020	Conducted (TH05-HY)
AC Power Source	ChainTek	APC-1000W	N/A	N/A	N/A	May 22, 2019	N/A	Conduction (CO05-HY)
EMI Test Receiver	Rohde & Schwarz	ESR3	102388	9KHz~3.6GHz	Nov. 12, 2018	May 22, 2019	Nov. 11, 2019	Conduction (CO05-HY)
LISN	Rohde & Schwarz	ENV216	100080	9kHz~30MHz	Nov. 14, 2018	May 22, 2019	Nov. 13, 2019	Conduction (CO05-HY)
LISN	Rohde & Schwarz	ENV216	100081	9kHz~30MHz	Nov. 09, 2018	May 22, 2019	Nov. 08, 2019	Conduction (CO05-HY)
Software	Rohde & Schwarz	EMC32 V10.30	N/A	N/A	N/A	May 22, 2019	N/A	Conduction (CO05-HY)
LF Cable	HUBER + SUHNER	RG-214/U	LF01	N/A	Dec. 31, 2018	May 22, 2019	Dec. 30, 2019	Conduction (CO05-HY)
Pulse Limiter	Rohde & Schwarz	ESH3-Z2	100851	N/A	Dec. 31, 2018	May 22, 2019	Dec. 30, 2019	Conduction (CO05-HY)
Loop Antenna	Rohde & Schwarz	HFH2-Z2	100488	9 kHz~30 MHz	Jan. 07, 2019	Jun. 03, 2019 ~ Jun. 21, 2019	Jan. 06, 2020	Radiation (03CH13-HY)
Horn Antenna	SCHWARZBECK	BBHA 9120 D	9120D-1241	1GHz ~ 18GHz	Jun. 29, 2018	Jun. 03, 2019 ~ Jun. 21, 2019	Jun. 28, 2019	Radiation (03CH13-HY)
Bilog Antenna	TESEQ	CBL 6111D&00800 N1D01N-06	37059&01	30MHz~1GHz	Oct. 13, 2018	Jun. 03, 2019 ~ Jun. 21, 2019	Oct. 12, 2019	Radiation (03CH13-HY)
SHF-EHF Horn Antenna	SCHWARZBECK	BBHA 9170	BBHA917058 4	18GHz- 40GHz	Dec. 05, 2018	Jun. 03, 2019 ~ Jun. 21, 2019	Dec. 04, 2019	Radiation (03CH13-HY)
Preamplifier	Keysight	83017A	MY53270080	1GHz~26.5GHz	Nov. 14, 2018	Jun. 03, 2019 ~ Jun. 21, 2019	Nov. 13, 2020	Radiation (03CH13-HY)
Preamplifier	MITEQ	AMF-7D-0010 1800-30-10P	1590074	1GHz~18GHz	May 20, 2019	Jun. 03, 2019 ~ Jun. 21, 2019	May 19, 2020	Radiation (03CH13-HY)
Amplifier	Sonoma-Instrument	310 N	187282	9KHz~1GHz	Dec. 18, 2018	Jun. 03, 2019 ~ Jun. 21, 2019	Dec. 17, 2019	Radiation (03CH13-HY)
Amplifier	MITEQ	TTA1840-35-H G	1871923	18GHz~40GHz, VSWR : 2.5:1 max	Jul. 16, 2018	Jun. 03, 2019 ~ Jun. 21, 2019	Jul. 15, 2019	Radiation (03CH13-HY)
RF Cable	HUBER + SUHNER	SUCOFLEX 126E	0030/126E	30M-18G	Feb. 13, 2019	Jun. 03, 2019 ~ Jun. 21, 2019	Feb. 12, 2020	Radiation (03CH13-HY)
RF Cable	HUBER + SUHNER	SUCOFLEX 104	804793/4	30M-18G	Feb. 13, 2019	Jun. 03, 2019 ~ Jun. 21, 2019	Feb. 12, 2020	Radiation (03CH13-HY)
RF Cable	HUBER + SUHNER	SUCOFLEX 104	MY24961/4	30M-18G	Feb. 13, 2019	Jun. 03, 2019 ~ Jun. 21, 2019	Feb. 12, 2020	Radiation (03CH13-HY)
RF Cable	HUBER + SUHNER	SUCOFLEX 102	MY2859/2	30M~40GHz	Mar. 13, 2019	Jun. 03, 2019 ~ Jun. 21, 2019	Mar. 12, 2020	Radiation (03CH13-HY)
RF Cable	HUBER + SUHNER	SUCOFLEX 102	MY4274/2	30M~40GHz	Mar. 13, 2019	Jun. 03, 2019 ~ Jun. 21, 2019	Mar. 12, 2020	Radiation (03CH13-HY)
Spectrum Analyzer	Keysight	N9010A	MY55370526	10Hz~44GHz	Mar. 19, 2019	Jun. 03, 2019 ~ Jun. 21, 2019	Mar. 18, 2020	Radiation (03CH13-HY)
Antenna Mast	EMEC	AM-BS-4500-B	N/A	1m~4m	N/A	Jun. 03, 2019 ~ Jun. 21, 2019	N/A	Radiation (03CH13-HY)
Turn Table	EMEC	TT2000	N/A	0~360 Degree	N/A	Jun. 03, 2019 ~ Jun. 21, 2019	N/A	Radiation (03CH13-HY)
Software	AUDIX	E3 6.2009-8-24c	RK-001124	N/A	N/A	Jun. 03, 2019 ~ Jun. 21, 2019	N/A	Radiation (03CH13-HY)



Instrument	Manufacturer	Model No.	Serial No.	Characteristics	Calibration Date	Test Date	Due Date	Remark
EMI Test Receiver	Keysight	N9038A(MXE)	MY54130085	20Hz ~ 8.4GHz	Nov. 01, 2018	Jun. 03, 2019 ~ Jun. 21, 2019	Oct. 31, 2019	Radiation (03CH13-HY)
Filter	Wainwright	WHKX12-1080 -1200-15000-6 0ST	SN3	1.2G Low Pass	Jul. 05, 2018	Jun. 03, 2019 ~ Jun. 21, 2019	Jul. 04, 2019	Radiation (03CH13-HY)
Filter	Wainwright	WHKX12-2700 -3000-18000-6 0SS	SN2	3G High Pass	Jul. 16, 2018	Jun. 03, 2019 ~ Jun. 21, 2019	Jul. 15, 2019	Radiation (03CH13-HY)



5 Uncertainty of Evaluation

Uncertainty of Conducted Emission Measurement (150kHz ~ 30MHz)

Measuring Uncertainty for a Level of Confidence of 95% ($U = 2Uc(y)$)	2.20
---	------

Uncertainty of Radiated Emission Measurement (30 MHz ~ 1000 MHz)

Measuring Uncertainty for a Level of Confidence of 95% ($U = 2Uc(y)$)	4.90
---	------

Uncertainty of Radiated Emission Measurement (1000 MHz ~ 18000 MHz)

Measuring Uncertainty for a Level of Confidence of 95% ($U = 2Uc(y)$)	5.40
---	------

Uncertainty of Radiated Emission Measurement (18000 MHz ~ 40000 MHz)

Measuring Uncertainty for a Level of Confidence of 95% ($U = 2Uc(y)$)	4.30
---	------

Appendix A. Test Result of Conducted Test Items

Test Engineer:	Hank Hsu	Temperature:	21~25	°C
Test Date:	2019/4/10 ~ 2019/6/22	Relative Humidity:	51~54	%

TEST RESULTS DATA
6dB and 99% Occupied Bandwidth

2.4GHz Band										
Mod.	Data Rate	NTX	CH.	Freq. (MHz)	99% Occupied BW (MHz)		6dB BW (MHz)		6dB BW Limit (MHz)	Pass/Fail
					Ant 2	Ant 4	Ant 2	Ant 4		
11b	1Mbps	2	1	2412	14.30	14.80	9.04	9.06	0.50	Pass
11b	1Mbps	2	6	2437	13.80	13.80	8.06	8.10	0.50	Pass
11b	1Mbps	2	11	2462	13.80	13.75	9.02	8.52	0.50	Pass
11b	1Mbps	2	12	2467	13.90	13.55	9.02	8.04	0.50	Pass
11b	1Mbps	2	13	2472	13.75	13.60	8.52	8.04	0.50	Pass
11g	6Mbps	2	1	2412	16.70	16.70	15.44	16.28	0.50	Pass
11g	6Mbps	2	6	2437	17.50	17.15	16.24	15.68	0.50	Pass
11g	6Mbps	2	11	2462	16.70	16.60	15.72	16.26	0.50	Pass
11g	6Mbps	2	12	2467	16.65	16.50	16.00	15.68	0.50	Pass
11g	6Mbps	2	13	2472	16.70	16.50	15.44	15.72	0.50	Pass
HT20	MCS0	2	1	2412	17.85	17.90	15.96	16.76	0.50	Pass
HT20	MCS0	2	6	2437	18.25	18.35	16.96	16.40	0.50	Pass
HT20	MCS0	2	11	2462	17.80	17.75	15.98	15.44	0.50	Pass
HT20	MCS0	2	12	2467	17.80	17.70	16.92	15.92	0.50	Pass
HT20	MCS0	2	13	2472	17.85	17.70	16.78	15.92	0.50	Pass

TEST RESULTS DATA
Average Output Power

2.4GHz Band																
Mod.	Data Rate	NTX	CH.	Freq. (MHz)	Average Conducted Power (dBm)			Conducted Power Limit (dBm)		DG (dBi)		EIRP Power (dBm)		EIRP Power Limit (dBm)		Pass /Fail
					Ant 2	Ant 4	SUM	Ant 2	Ant 4	Ant 2	Ant 4	Ant 2	Ant 4	Ant 2	Ant 4	
11b	1Mbps	1	1	2412	22.60	22.60		30.00	30.00	-0.50	-2.90	22.10	19.70	36.00	36.00	Pass
11b	1Mbps	1	6	2437	19.90	19.90		30.00	30.00	-0.50	-2.90	19.40	17.00	36.00	36.00	Pass
11b	1Mbps	1	11	2462	19.80	19.80		30.00	30.00	-0.50	-2.90	19.30	16.90	36.00	36.00	Pass
11b	1Mbps	1	12	2467	17.10	16.80		30.00	30.00	-0.50	-2.90	16.60	13.90	36.00	36.00	Pass
11b	1Mbps	1	13	2472	16.90	16.90		30.00	30.00	-0.50	-2.90	16.40	14.00	36.00	36.00	Pass
11g	6Mbps	1	1	2412	19.80	19.70		30.00	30.00	-0.50	-2.90	19.30	16.80	36.00	36.00	Pass
11g	6Mbps	1	6	2437	21.40	21.30		30.00	30.00	-0.50	-2.90	20.90	18.40	36.00	36.00	Pass
11g	6Mbps	1	11	2462	18.80	18.70		30.00	30.00	-0.50	-2.90	18.30	15.80	36.00	36.00	Pass
11g	6Mbps	1	12	2467	14.70	14.60		30.00	30.00	-0.50	-2.90	14.20	11.70	36.00	36.00	Pass
11g	6Mbps	1	13	2472	3.20	3.00		30.00	30.00	-0.50	-2.90	2.70	0.10	36.00	36.00	Pass
HT20	MCS0	1	1	2412	19.70	19.60		30.00	30.00	-0.50	-2.90	19.20	16.70	36.00	36.00	Pass
HT20	MCS0	1	6	2437	21.10	20.90		30.00	30.00	-0.50	-2.90	20.60	18.00	36.00	36.00	Pass
HT20	MCS0	1	11	2462	15.90	15.90		30.00	30.00	-0.50	-2.90	15.40	13.00	36.00	36.00	Pass
HT20	MCS0	1	12	2467	12.60	12.60		30.00	30.00	-0.50	-2.90	12.10	9.70	36.00	36.00	Pass
HT20	MCS0	1	13	2472	4.00	3.80		30.00	30.00	-0.50	-2.90	3.50	0.90	36.00	36.00	Pass
VHT20	MCS0	1	1	2412	19.70	19.30		30.00	30.00	-0.50	-2.90	19.20	16.40	36.00	36.00	Pass
VHT20	MCS0	1	6	2437	21.00	20.80		30.00	30.00	-0.50	-2.90	20.50	17.90	36.00	36.00	Pass
VHT20	MCS0	1	11	2462	15.80	15.90		30.00	30.00	-0.50	-2.90	15.30	13.00	36.00	36.00	Pass
VHT20	MCS0	1	12	2467	12.60	12.50		30.00	30.00	-0.50	-2.90	12.10	9.60	36.00	36.00	Pass
VHT20	MCS0	1	13	2472	4.10	3.90		30.00	30.00	-0.50	-2.90	3.60	1.00	36.00	36.00	Pass
11b	1Mbps	2	1	2412	23.00	22.70	25.86	30.00		-0.50		25.36		36.00		Pass
11b	1Mbps	2	6	2437	20.10	19.80	22.96	30.00		-0.50		22.46		36.00		Pass
11b	1Mbps	2	11	2462	20.10	19.60	22.87	30.00		-0.50		22.37		36.00		Pass
11b	1Mbps	2	12	2467	17.40	16.70	20.07	30.00		-0.50		19.57		36.00		Pass
11b	1Mbps	2	13	2472	17.20	16.70	19.97	30.00		-0.50		19.47		36.00		Pass
11g	6Mbps	2	1	2412	20.20	19.70	22.97	30.00		-0.50		22.47		36.00		Pass
11g	6Mbps	2	6	2437	21.70	21.20	24.47	30.00		-0.50		23.97		36.00		Pass
11g	6Mbps	2	11	2462	19.10	18.60	21.87	30.00		-0.50		21.37		36.00		Pass
11g	6Mbps	2	12	2467	15.10	14.40	17.77	30.00		-0.50		17.27		36.00		Pass
11g	6Mbps	2	13	2472	3.20	3.30	6.26	30.00		-0.50		5.76		36.00		Pass
HT20	MCS0	2	1	2412	20.00	19.60	22.81	30.00		-0.50		22.31		36.00		Pass
HT20	MCS0	2	6	2437	21.40	20.90	24.17	30.00		-0.50		23.67		36.00		Pass
HT20	MCS0	2	11	2462	16.30	15.70	19.02	30.00		-0.50		18.52		36.00		Pass
HT20	MCS0	2	12	2467	13.00	12.30	15.67	30.00		-0.50		15.17		36.00		Pass
HT20	MCS0	2	13	2472	4.10	4.20	7.16	30.00		-0.50		6.66		36.00		Pass
VHT20	MCS0	2	1	2412	19.90	19.50	22.71	30.00		-0.50		22.21		36.00		Pass
VHT20	MCS0	2	6	2437	21.40	20.80	24.12	30.00		-0.50		23.62		36.00		Pass
VHT20	MCS0	2	11	2462	16.20	15.70	18.97	30.00		-0.50		18.47		36.00		Pass
VHT20	MCS0	2	12	2467	13.00	12.30	15.67	30.00		-0.50		15.17		36.00		Pass
VHT20	MCS0	2	13	2472	4.00	4.20	7.11	30.00		-0.50		6.61		36.00		Pass

Note: Measured power (dBm) has offset with cable loss.

TEST RESULTS DATA
Peak Power Spectral Density

2.4GHz Band												
Mod.	Data Rate	N _{TX}	CH.	Freq. (MHz)	Peak PSD (dBm/3kHz)			DG (dBi)		Peak PSD Limit (dBm/3kHz)		Pass/Fail
					Ant 2	Ant 4	Worse + 3.01	Ant 2	Ant 4	Ant 2	Ant 4	
11b	1Mbps	2	1	2412	0.57	-1.01	3.58	1.39		8.00		Pass
11b	1Mbps	2	6	2437	-2.99	-2.50	0.51	1.39		8.00		Pass
11b	1Mbps	2	11	2462	-2.17	-1.90	1.11	1.39		8.00		Pass
11b	1Mbps	2	12	2467	-5.09	-6.14	-2.08	1.39		8.00		Pass
11b	1Mbps	2	13	2472	-5.54	-5.11	-2.10	1.39		8.00		Pass
11g	6Mbps	2	1	2412	-6.81	-8.14	-3.80	1.39		8.00		Pass
11g	6Mbps	2	6	2437	-3.61	-3.98	-0.60	1.39		8.00		Pass
11g	6Mbps	2	11	2462	-5.69	-7.31	-2.68	1.39		8.00		Pass
11g	6Mbps	2	12	2467	-10.19	-13.25	-7.18	1.39		8.00		Pass
11g	6Mbps	2	13	2472	-23.60	-23.38	-20.37	1.39		8.00		Pass
HT20	MCS0	2	1	2412	-7.11	-8.35	-4.10	1.39		8.00		Pass
HT20	MCS0	2	6	2437	-4.42	-4.39	-1.38	1.39		8.00		Pass
HT20	MCS0	2	11	2462	-10.51	-11.54	-7.50	1.39		8.00		Pass
HT20	MCS0	2	12	2467	-13.99	-15.24	-10.98	1.39		8.00		Pass
HT20	MCS0	2	13	2472	-22.16	-22.73	-19.15	1.39		8.00		Pass

Measured power density (dBm) has offset with cable loss.



Appendix B. AC Conducted Emission Test Results

Test Engineer :	Jimmy Chang	Temperature :	24~26°C
		Relative Humidity :	51~54%

EUT Information

Report NO : 8N0620-05
 Test Mode : Mode 2
 Test Voltage : 120Vac/60Hz
 Phase : Line

Full Spectrum

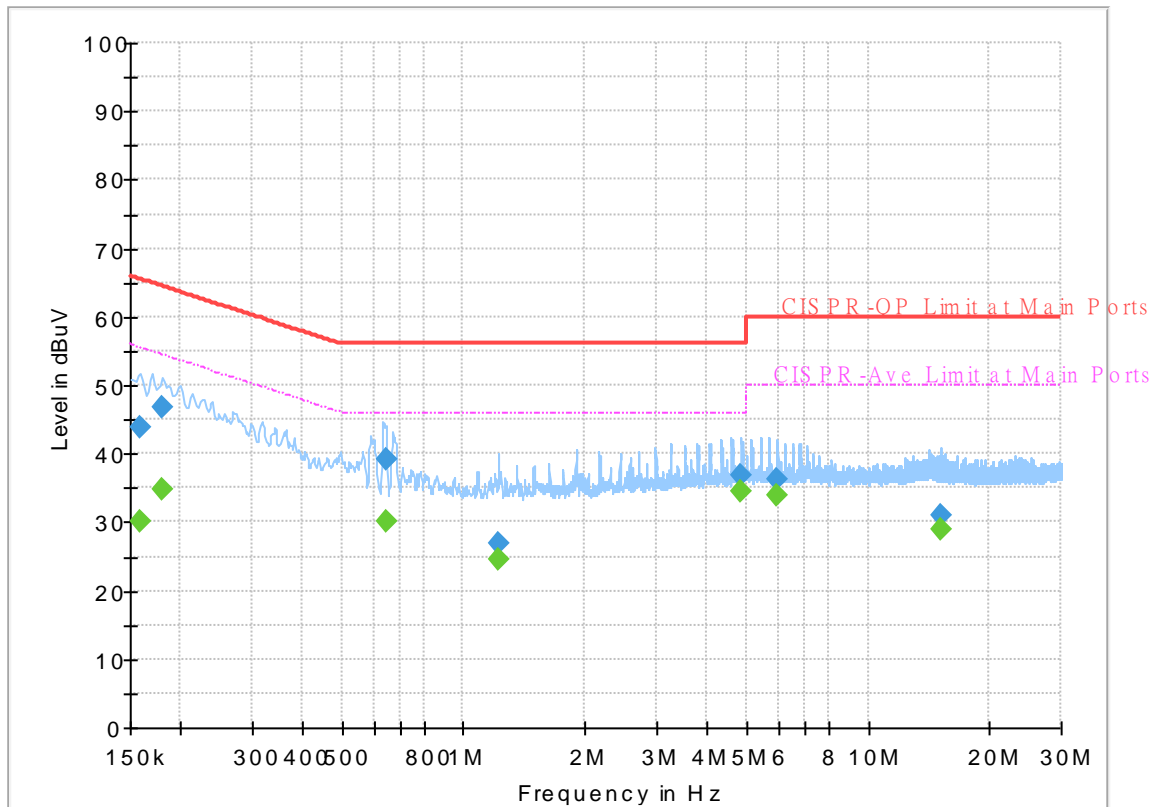

Final Result

Frequency (MHz)	QuasiPeak (dBuV)	CAverage (dBuV)	Limit (dBuV)	Margin (dB)	Line	Filter	Corr. (dB)
0.159000	---	29.97	55.52	25.55	L1	OFF	19.5
0.159000	43.85	---	65.52	21.67	L1	OFF	19.5
0.179250	---	34.77	54.52	19.75	L1	OFF	19.5
0.179250	46.91	---	64.52	17.61	L1	OFF	19.5
0.642750	---	30.21	46.00	15.79	L1	OFF	19.6
0.642750	39.31	---	56.00	16.69	L1	OFF	19.6
1.221000	---	24.58	46.00	21.42	L1	OFF	19.6
1.221000	26.85	---	56.00	29.15	L1	OFF	19.6
4.870500	---	34.58	46.00	11.42	L1	OFF	19.7
4.870500	36.78	---	56.00	19.22	L1	OFF	19.7
5.952750	---	33.89	50.00	16.11	L1	OFF	19.8
5.952750	36.34	---	60.00	23.66	L1	OFF	19.8
15.191250	---	28.84	50.00	21.16	L1	OFF	20.1
15.191250	31.10	---	60.00	28.90	L1	OFF	20.1

EUT Information

Report NO : 8N0620-05
 Test Mode : Mode 2
 Test Voltage : 120Vac/60Hz
 Phase : Neutral

Full Spectrum

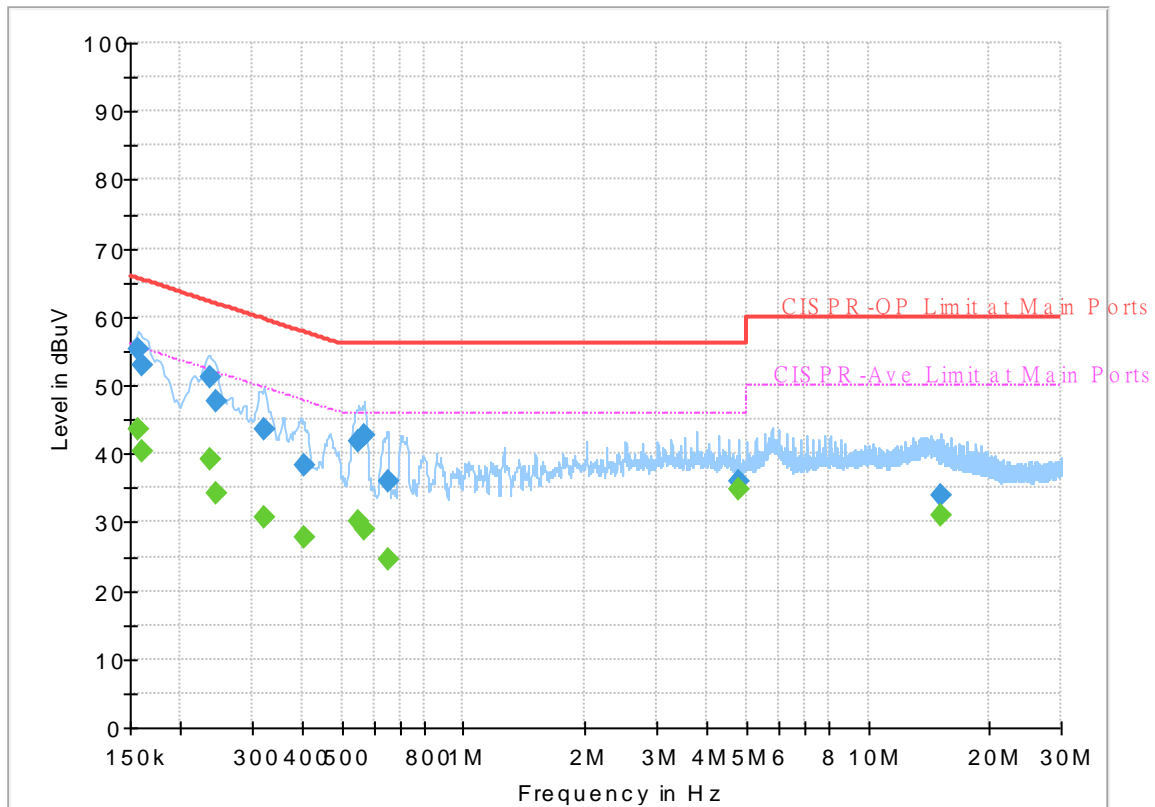

Final_Result

Frequency (MHz)	QuasiPeak (dBuV)	CAverage (dBuV)	Limit (dBuV)	Margin (dB)	Line	Filter	Corr. (dB)
0.156750	---	43.67	55.63	11.96	N	OFF	19.5
0.156750	55.35	---	65.63	10.28	N	OFF	19.5
0.161250	---	40.38	55.40	15.02	N	OFF	19.5
0.161250	53.04	---	65.40	12.36	N	OFF	19.5
0.235500	---	39.29	52.25	12.96	N	OFF	19.5
0.235500	51.05	---	62.25	11.20	N	OFF	19.5
0.244500	---	34.15	51.94	17.79	N	OFF	19.5
0.244500	47.76	---	61.94	14.18	N	OFF	19.5
0.323250	---	30.65	49.62	18.97	N	OFF	19.5
0.323250	43.48	---	59.62	16.14	N	OFF	19.5
0.402000	---	27.70	47.81	20.11	N	OFF	19.5
0.402000	38.39	---	57.81	19.42	N	OFF	19.5
0.550500	---	30.19	46.00	15.81	N	OFF	19.5
0.550500	41.92	---	56.00	14.08	N	OFF	19.5
0.568500	---	29.03	46.00	16.97	N	OFF	19.5
0.568500	42.63	---	56.00	13.37	N	OFF	19.5
0.649500	---	24.61	46.00	21.39	N	OFF	19.6
0.649500	35.92	---	56.00	20.08	N	OFF	19.6
4.778250	---	34.75	46.00	11.25	N	OFF	19.7
4.778250	36.00	---	56.00	20.00	N	OFF	19.7
15.087750	---	31.04	50.00	18.96	N	OFF	20.1
15.087750	34.05	---	60.00	25.95	N	OFF	20.1



Appendix C. Radiated Spurious Emission

Test Engineer :	JC Liang and Wilson Wu	Temperature :	25.1~25.2°C
		Relative Humidity :	50~52%

2.4GHz 2400~2483.5MHz

WIFI 802.11b (Band Edge @ 3m)

WIFI Ant.	Note	Frequency (MHz)	Level (dBμV/m)	Over Limit (dB)	Limit Line (dBμV/m)	Read Level (dBμV)	Antenna Factor (dB/m)	Path Loss (dB)	Preamp Factor (dB)	Ant Pos (cm)	Table Pos (deg)	Peak Avg. (P/A)	Pol. (H/V)	
802.11b CH 01 2412MHz		2345.28	52.71	-21.29	74	41.31	27.1	13.89	29.59	303	237	P	H	
		2389.28	43.46	-10.54	54	31.89	27.23	13.92	29.58	303	237	A	H	
	*	2412	112.76	-	-	101.12	27.28	13.94	29.58	303	237	P	H	
	*	2412	109.47	-	-	97.83	27.28	13.94	29.58	303	237	A	H	
													H	
														H
			2389.59	52.65	-21.35	74	41.08	27.23	13.92	29.58	351	279	P	V
			2390	42.95	-11.05	54	31.38	27.23	13.92	29.58	351	279	A	V
	*		2412	109.78	-	-	98.14	27.28	13.94	29.58	351	279	P	V
	*		2412	106.41	-	-	94.77	27.28	13.94	29.58	351	279	A	V
														V
														V



WIFI Ant. 2+4	Note	Frequency (MHz)	Level (dBμV/m)	Over Limit (dB)	Limit Line (dBμV/m)	Read Level (dBμV)	Antenna Factor (dB/m)	Path Loss (dB)	Preamp Factor (dB)	Ant Pos (cm)	Table Pos (deg)	Peak Avg. (P/A)	Pol. (H/V)
802.11b CH 06 2437MHz		2380	52.23	-21.77	74	40.71	27.19	13.91	29.58	100	100	P	H
		2389.94	41.4	-12.6	54	29.83	27.23	13.92	29.58	100	100	A	H
	*	2437	111.96	-	-	100.21	27.37	13.96	29.58	100	100	P	H
	*	2437	109.01	-	-	97.26	27.37	13.96	29.58	100	100	A	H
		2484.95	53.39	-20.61	74	41.5	27.46	14	29.57	100	100	P	H
		2483.76	42.49	-11.51	54	30.6	27.46	14	29.57	100	100	A	H
		2361.1	52.14	-21.86	74	40.69	27.14	13.9	29.59	386	289	P	V
		2389.94	41.36	-12.64	54	29.79	27.23	13.92	29.58	386	289	A	V
	*	2437	108.88	-	-	97.13	27.37	13.96	29.58	386	289	P	V
	*	2437	105.63	-	-	93.88	27.37	13.96	29.58	386	289	A	V
		2483.9	52.82	-21.18	74	40.93	27.46	14	29.57	386	289	P	V
		2483.97	41.93	-12.07	54	30.04	27.46	14	29.57	386	289	A	V
802.11b CH 11 2462MHz	*	2462	112.37	-	-	100.55	27.41	13.98	29.57	129	99	P	H
	*	2462	109.33	-	-	97.51	27.41	13.98	29.57	129	99	A	H
		2488.24	55.44	-18.56	74	43.5	27.5	14.01	29.57	129	99	P	H
		2486.8	46.99	-7.01	54	35.1	27.46	14	29.57	129	99	A	H
													H
													H
	*	2462	108.25	-	-	96.43	27.41	13.98	29.57	378	298	P	V
	*	2462	104.93	-	-	93.11	27.41	13.98	29.57	378	298	A	V
		2486.28	54.52	-19.48	74	42.63	27.46	14	29.57	378	298	P	V
		2483.52	43.33	-10.67	54	31.44	27.46	14	29.57	378	298	A	V
												V	
												V	
Remark	1. No other spurious found. 2. All results are PASS against Peak and Average limit line.												



WIFI Ant. 2+4	Note	Frequency (MHz)	Level (dBμV/m)	Over Limit (dB)	Limit Line (dBμV/m)	Read Level (dBμV)	Antenna Factor (dB/m)	Path Loss (dB)	Preamp Factor (dB)	Ant Pos (cm)	Table Pos (deg)	Peak Avg. (P/A)	Pol. (H/V)
802.11b CH 12 2467MHz	*	2467	109.12	-	-	97.29	27.41	13.99	29.57	325	224	P	H
	*	2467	105.88	-	-	94.05	27.41	13.99	29.57	325	224	A	H
		2483.88	57.95	-16.05	74	46.06	27.46	14	29.57	325	224	P	H
		2484.28	51.81	-2.19	54	39.92	27.46	14	29.57	325	224	A	H
													H
													H
	*	2467	107.82	-	-	95.99	27.41	13.99	29.57	329	283	P	V
	*	2467	104.53	-	-	92.7	27.41	13.99	29.57	329	283	A	V
		2483.84	58.89	-15.11	74	47	27.46	14	29.57	329	283	P	V
		2484.24	52.41	-1.59	54	40.52	27.46	14	29.57	329	283	A	V
													V
													V
802.11b CH 13 2472MHz	*	2472	109.24	-	-	97.36	27.46	13.99	29.57	325	238	P	H
	*	2472	106.1	-	-	94.22	27.46	13.99	29.57	325	238	A	H
		2483.56	58.09	-15.91	74	46.2	27.46	14	29.57	325	238	P	H
		2483.52	51.37	-2.63	54	39.48	27.46	14	29.57	325	238	A	H
													H
													H
	*	2472	106.89	-	-	95.01	27.46	13.99	29.57	327	280	P	V
	*	2472	103.76	-	-	91.88	27.46	13.99	29.57	327	280	A	V
		2483.52	58.94	-15.06	74	47.05	27.46	14	29.57	327	280	P	V
		2483.52	52.11	-1.89	54	40.22	27.46	14	29.57	327	280	A	V
													V
													V
Remark	1. No other spurious found. 2. All results are PASS against Peak and Average limit line.												



**2.4GHz 2400~2483.5MHz
WIFI 802.11b (Harmonic @ 3m)**

WIFI Ant. 2+4	Note	Frequency (MHz)	Level (dBμV/m)	Over Limit (dB)	Limit Line (dBμV/m)	Read Level (dBμV)	Antenna Factor (dB/m)	Path Loss (dB)	Preamp Factor (dB)	Ant Pos (cm)	Table Pos (deg)	Peak Avg. (P/A)	Pol. (H/V)
802.11b CH 01 2412MHz		4824	40.93	-33.07	74	60.8	31.26	6.42	57.55	100	0	P	H
		12060	49.18	-24.82	74	55.98	38.82	10.72	56.34	100	0	P	H
													H
													H
		4824	41.22	-32.78	74	61.09	31.26	6.42	57.55	100	0	P	V
		12060	53.45	-20.55	74	60.25	38.82	10.72	56.34	100	89	P	V
		12060	48.44	-5.56	54	55.24	38.82	10.72	56.34	100	89	A	V
802.11b CH 06 2437MHz		4874	38.23	-35.77	74	57.76	31.36	6.56	57.45	100	0	P	H
		7311	50.29	-23.71	74	63.18	36.18	8.2	57.27	101	145	P	H
		7311	45.53	-8.47	54	58.42	36.18	8.2	57.27	101	145	A	H
													H
		4874	39.73	-34.27	74	59.26	31.36	6.56	57.45	100	0	P	V
		7311	55.57	-18.43	74	68.46	36.18	8.2	57.27	102	130	P	V
		7311	51.72	-2.28	54	64.61	36.18	8.2	57.27	102	130	A	V
802.11b CH 11 2462MHz		4924	38.29	-35.71	74	57.48	31.46	6.7	57.35	100	0	P	H
		7386	51.74	-22.26	74	64.59	36.37	8.14	57.36	105	146	P	H
		7386	47.27	-6.73	54	60.12	36.37	8.14	57.36	105	146	A	H
													H
		4924	39.85	-34.15	74	59.04	31.46	6.7	57.35	100	0	P	V
		7386	55.91	-18.09	74	68.76	36.37	8.14	57.36	100	140	P	V
		7386	52.48	-1.52	54	65.33	36.37	8.14	57.36	100	140	A	V
Remark	1. No other spurious found. 2. All results are PASS against Peak and Average limit line.												



WIFI Ant. 2+4	Note	Frequency (MHz)	Level (dBμV/m)	Over Limit (dB)	Limit Line (dBμV/m)	Read Level (dBμV)	Antenna Factor (dB/m)	Path Loss (dB)	Preamp Factor (dB)	Ant Pos (cm)	Table Pos (deg)	Peak Avg. (P/A)	Pol. (H/V)
802.11b CH 12 2467MHz		4934	38.31	-35.69	74	57.45	31.46	6.73	57.33	100	0	P	H
		7401	53.14	-20.86	74	65.98	36.41	8.13	57.38	100	268	P	H
		7401	48.9	-5.1	54	61.74	36.41	8.13	57.38	100	268	A	H
													H
		4934	39.01	-34.99	74	58.15	31.46	6.73	57.33	100	0	P	V
		7401	51.94	-22.06	74	64.78	36.41	8.13	57.38	100	130	P	V
		7401	46.46	-7.54	54	59.3	36.41	8.13	57.38	100	130	A	V
802.11b CH 13 2472MHz		4944	38.03	-35.97	74	57.08	31.5	6.76	57.31	100	0	P	H
		7416	52.97	-21.03	74	65.8	36.41	8.16	57.4	103	248	P	H
		7416	48.53	-5.47	54	61.36	36.41	8.16	57.4	103	248	A	H
													H
		4944	39.34	-34.66	74	58.39	31.5	6.76	57.31	100	0	P	V
		7416	53.91	-20.09	74	66.74	36.41	8.16	57.4	102	127	P	V
		7416	50.26	-3.74	54	63.09	36.41	8.16	57.4	102	127	A	V
Remark	1. No other spurious found. 2. All results are PASS against Peak and Average limit line.												



2.4GHz 2400~2483.5MHz
WIFI 802.11g (Band Edge @ 3m)

WIFI Ant. 2+4	Note	Frequency (MHz)	Level (dBμV/m)	Over Limit (dB)	Limit Line (dBμV/m)	Read Level (dBμV)	Antenna Factor (dB/m)	Path Loss (dB)	Preamp Factor (dB)	Ant Pos (cm)	Table Pos (deg)	Peak Avg. (P/A)	Pol. (H/V)	
802.11g CH 01 2412MHz		2367.75	52.71	-21.29	74	41.26	27.14	13.9	29.59	114	243	P	H	
		2390	44.6	-9.4	54	33.03	27.23	13.92	29.58	114	243	A	H	
	*	2412	112.67	-	-	101.03	27.28	13.94	29.58	114	243	P	H	
	*	2412	105.62	-	-	93.98	27.28	13.94	29.58	114	243	A	H	
													H	
														H
			2390	53.08	-20.92	74	41.51	27.23	13.92	29.58	391	266	P	V
			2390	43.9	-10.1	54	32.33	27.23	13.92	29.58	391	266	A	V
	*		2412	110.17	-	-	98.53	27.28	13.94	29.58	391	266	P	V
	*		2412	102.6	-	-	90.96	27.28	13.94	29.58	391	266	A	V
														V
														V
802.11g CH 06 2437MHz		2389.24	53.26	-20.74	74	41.69	27.23	13.92	29.58	107	216	P	H	
		2389.94	44.32	-9.68	54	32.75	27.23	13.92	29.58	107	216	A	H	
	*	2437	115.94	-	-	104.19	27.37	13.96	29.58	107	216	P	H	
	*	2437	108.62	-	-	96.87	27.37	13.96	29.58	107	216	A	H	
			2484.25	56.5	-17.5	74	44.61	27.46	14	29.57	107	216	P	H
			2483.69	46.98	-7.02	54	35.09	27.46	14	29.57	107	216	A	H
			2358.58	52.54	-21.46	74	41.09	27.14	13.9	29.59	386	296	P	V
			2389.8	42.85	-11.15	54	31.28	27.23	13.92	29.58	386	296	A	V
	*		2437	115.14	-	-	103.39	27.37	13.96	29.58	386	296	P	V
	*		2437	107.07	-	-	95.32	27.37	13.96	29.58	386	296	A	V
			2484.04	53.73	-20.27	74	41.84	27.46	14	29.57	386	296	P	V
			2484.18	44.18	-9.82	54	32.29	27.46	14	29.57	386	296	A	V



WIFI Ant. 2+4	Note	Frequency (MHz)	Level (dBμV/m)	Over Limit (dB)	Limit Line (dBμV/m)	Read Level (dBμV)	Antenna Factor (dB/m)	Path Loss (dB)	Preamp Factor (dB)	Ant Pos (cm)	Table Pos (deg)	Peak Avg. (P/A)	Pol. (H/V)
802.11g CH 11 2462MHz	*	2462	114.36	-	-	102.54	27.41	13.98	29.57	135	217	P	H
	*	2462	106.76	-	-	94.94	27.41	13.98	29.57	135	217	A	H
		2484.68	63.03	-10.97	74	51.14	27.46	14	29.57	135	217	P	H
		2484.72	52.17	-1.83	54	40.28	27.46	14	29.57	135	217	A	H
													H
													H
	*	2462	112.23	-	-	100.41	27.41	13.98	29.57	377	298	P	V
	*	2462	104.31	-	-	92.49	27.41	13.98	29.57	377	298	A	V
		2484.84	59.75	-14.25	74	47.86	27.46	14	29.57	377	298	P	V
		2485.16	50.12	-3.88	54	38.23	27.46	14	29.57	377	298	A	V
													V
													V
Remark	<ol style="list-style-type: none"> No other spurious found. All results are PASS against Peak and Average limit line. 												



WIFI Ant. 2+4	Note	Frequency (MHz)	Level (dBμV/m)	Over Limit (dB)	Limit Line (dBμV/m)	Read Level (dBμV)	Antenna Factor (dB/m)	Path Loss (dB)	Preamp Factor (dB)	Ant Pos (cm)	Table Pos (deg)	Peak Avg. (P/A)	Pol. (H/V)
802.11g CH 12 2467MHz	*	2467	107.72	-	-	95.89	27.41	13.99	29.57	100	229	P	H
	*	2467	100.32	-	-	88.49	27.41	13.99	29.57	100	229	A	H
		2486.52	61.89	-12.11	74	50	27.46	14	29.57	100	229	P	H
		2483.52	52.05	-1.95	54	40.16	27.46	14	29.57	100	229	A	H
													H
													H
	*	2467	104.86	-	-	93.03	27.41	13.99	29.57	287	267	P	V
	*	2467	97.24	-	-	85.41	27.41	13.99	29.57	287	267	A	V
		2486.28	60.13	-13.87	74	48.24	27.46	14	29.57	287	267	P	V
		2485.88	47.83	-6.17	54	35.94	27.46	14	29.57	287	267	A	V
													V
													V
802.11g CH 13 2472MHz	*	2472	96.3	-	-	84.42	27.46	13.99	29.57	100	246	P	H
	*	2472	88.9	-	-	77.02	27.46	13.99	29.57	100	246	A	H
		2483.56	63.49	-10.51	74	51.6	27.46	14	29.57	100	246	P	H
		2483.52	52.05	-1.95	54	40.16	27.46	14	29.57	100	246	A	H
													H
													H
	*	2472	93.34	-	-	81.46	27.46	13.99	29.57	287	267	P	V
	*	2472	86.02	-	-	74.14	27.46	13.99	29.57	287	267	A	V
		2483.56	59.5	-14.5	74	47.61	27.46	14	29.57	287	267	P	V
		2483.52	47.79	-6.21	54	35.9	27.46	14	29.57	287	267	A	V
													V
													V
Remark	1. No other spurious found. 2. All results are PASS against Peak and Average limit line.												



**2.4GHz 2400~2483.5MHz
WIFI 802.11g (Harmonic @ 3m)**

WIFI Ant. 2+4	Note	Frequency (MHz)	Level (dBμV/m)	Over Limit (dB)	Limit Line (dBμV/m)	Read Level (dBμV)	Antenna Factor (dB/m)	Path Loss (dB)	Preamp Factor (dB)	Ant Pos (cm)	Table Pos (deg)	Peak Avg. (P/A)	Pol. (H/V)	
802.11g CH 01 2412MHz		4824	38.66	-35.34	74	58.53	31.26	6.42	57.55	100	0	P	H	
													H	
													H	
													H	
			4824	38.32	-35.68	74	58.19	31.26	6.42	57.55	100	0	P	V
														V
														V
802.11g CH 06 2437MHz		4874	38.63	-35.37	74	58.16	31.36	6.56	57.45	100	0	P	H	
		7311	56.51	-17.49	74	69.4	36.18	8.2	57.27	100	144	P	H	
		7311	47.24	-6.76	54	60.13	36.18	8.2	57.27	100	144	A	H	
													H	
			4874	40.15	-33.85	74	59.68	31.36	6.56	57.45	100	0	P	V
			7311	61.61	-12.39	74	74.5	36.18	8.2	57.27	101	132	P	V
			7311	52.3	-1.7	54	65.19	36.18	8.2	57.27	101	132	A	V
802.11g CH 11 2462MHz		4924	38.24	-35.76	74	57.43	31.46	6.7	57.35	100	0	P	H	
		7386	49.34	-24.66	74	62.19	36.37	8.14	57.36	100	0	P	H	
													H	
													H	
			4924	37.5	-36.5	74	56.69	31.46	6.7	57.35	100	0	P	V
			7386	58.14	-15.86	74	70.99	36.37	8.14	57.36	250	280	P	V
			7386	48.56	-5.44	54	61.41	36.37	8.14	57.36	250	280	A	V
													V	
Remark	1. No other spurious found. 2. All results are PASS against Peak and Average limit line.													



WIFI Ant. 2+4	Note	Frequency (MHz)	Level (dBμV/m)	Over Limit (dB)	Limit Line (dBμV/m)	Read Level (dBμV)	Antenna Factor (dB/m)	Path Loss (dB)	Preamp Factor (dB)	Ant Pos (cm)	Table Pos (deg)	Peak Avg. (P/A)	Pol. (H/V)	
802.11g CH 12 2467MHz		4934	38.02	-35.98	74	57.16	31.46	6.73	57.33	100	0	P	H	
		7401	55.22	-18.78	74	68.06	36.41	8.13	57.38	119	250	P	H	
		7401	45.21	-8.79	54	58.05	36.41	8.13	57.38	119	250	A	H	
													H	
		4934	37.96	-36.04	74	57.1	31.46	6.73	57.33	100	0	P	V	
		7401	57.19	-16.81	74	70.03	36.41	8.13	57.38	282	297	P	V	
		7401	47.18	-6.82	54	60.02	36.41	8.13	57.38	282	297	A	V	
														V
802.11g CH 13 2472MHz		4944	38.29	-35.71	74	57.34	31.5	6.76	57.31	100	0	P	H	
		7416	43.19	-30.81	74	56.02	36.41	8.16	57.4	100	0	P	H	
													H	
													H	
		4944	38.1	-35.9	74	57.15	31.5	6.76	57.31	100	0	P	V	
		7416	43.09	-30.91	74	55.92	36.41	8.16	57.4	100	0	P	V	
														V
														V
Remark	1. No other spurious found. 2. All results are PASS against Peak and Average limit line.													



**2.4GHz 2400~2483.5MHz
WIFI 802.11n HT20 (Band Edge @ 3m)**

WIFI Ant. 2+4	Note	Frequency (MHz)	Level (dBμV/m)	Over Limit (dB)	Limit Line (dBμV/m)	Read Level (dBμV)	Antenna Factor (dB/m)	Path Loss (dB)	Preamp Factor (dB)	Ant Pos (cm)	Table Pos (deg)	Peak Avg. (P/A)	Pol. (H/V)	
802.11n HT20 CH 01 2412MHz		2389.695	59.1	-14.9	74	47.53	27.23	13.92	29.58	114	226	P	H	
		2390	48.09	-5.91	54	36.52	27.23	13.92	29.58	114	226	A	H	
	*	2412	112.72	-	-	101.08	27.28	13.94	29.58	114	226	P	H	
	*	2412	104.62	-	-	92.98	27.28	13.94	29.58	114	226	A	H	
													H	
														H
			2390	58.9	-15.1	74	47.33	27.23	13.92	29.58	391	266	P	V
			2390	47.04	-6.96	54	35.47	27.23	13.92	29.58	391	266	A	V
		*	2412	109	-	-	97.36	27.28	13.94	29.58	391	266	P	V
		*	2412	100.97	-	-	89.33	27.28	13.94	29.58	391	266	A	V
													V	
													V	
802.11n HT20 CH 06 2437MHz		2380.7	53	-21	74	41.48	27.19	13.91	29.58	100	100	P	H	
		2389.8	42.7	-11.3	54	31.13	27.23	13.92	29.58	100	100	A	H	
	*	2437	115.08	-	-	103.33	27.37	13.96	29.58	100	100	P	H	
	*	2437	107.34	-	-	95.59	27.37	13.96	29.58	100	100	A	H	
			2483.69	56.28	-17.72	74	44.39	27.46	14	29.57	100	100	P	H
			2484.04	46.19	-7.81	54	34.3	27.46	14	29.57	100	100	A	H
			2371.32	52.31	-21.69	74	40.8	27.19	13.91	29.59	386	295	P	V
			2389.8	42.94	-11.06	54	31.37	27.23	13.92	29.58	386	295	A	V
		*	2437	113.23	-	-	101.48	27.37	13.96	29.58	386	295	P	V
		*	2437	105.57	-	-	93.82	27.37	13.96	29.58	386	295	A	V
		2483.69	54.18	-19.82	74	42.29	27.46	14	29.57	386	295	P	V	
		2484.32	44.22	-9.78	54	32.33	27.46	14	29.57	386	295	A	V	



WIFI Ant. 2+4	Note	Frequency (MHz)	Level (dBµV/m)	Over Limit (dB)	Limit Line (dBµV/m)	Read Level (dBµV)	Antenna Factor (dB/m)	Path Loss (dB)	Preamp Factor (dB)	Ant Pos (cm)	Table Pos (deg)	Peak Avg. (P/A)	Pol. (H/V)
802.11n HT20 CH 11 2462MHz	*	2462	109.26	-	-	97.44	27.41	13.98	29.57	100	227	P	H
	*	2462	101.61	-	-	89.79	27.41	13.98	29.57	100	227	A	H
		2484.64	62.97	-11.03	74	51.08	27.46	14	29.57	100	227	P	H
		2483.52	51.82	-2.18	54	39.93	27.46	14	29.57	100	227	A	H
													H
													H
	*	2462	106.26	-	-	94.44	27.41	13.98	29.57	293	266	P	V
	*	2462	98.54	-	-	86.72	27.41	13.98	29.57	293	266	A	V
		2483.56	60.4	-13.6	74	48.51	27.46	14	29.57	293	266	P	V
		2483.64	49.22	-4.78	54	37.33	27.46	14	29.57	293	266	A	V
												V	
												V	

Remark

- No other spurious found.
- All results are PASS against Peak and Average limit line.



WIFI Ant. 2+4	Note	Frequency (MHz)	Level (dBμV/m)	Over Limit (dB)	Limit Line (dBμV/m)	Read Level (dBμV)	Antenna Factor (dB/m)	Path Loss (dB)	Preamp Factor (dB)	Ant Pos (cm)	Table Pos (deg)	Peak Avg. (P/A)	Pol. (H/V)	
802.11n HT20 CH 12 2467MHz	*	2467	106.08	-	-	94.25	27.41	13.99	29.57	100	227	P	H	
	*	2467	98.1	-	-	86.27	27.41	13.99	29.57	100	227	A	H	
		2483.52	62.9	-11.1	74	51.01	27.46	14	29.57	100	227	P	H	
		2483.52	52.15	-1.85	54	40.26	27.46	14	29.57	100	227	A	H	
													H	
														H
	*	2467	102.24	-	-	90.41	27.41	13.99	29.57	291	265	P	V	
	*	2467	94.16	-	-	82.33	27.41	13.99	29.57	291	265	A	V	
		2483.56	61.88	-12.12	74	49.99	27.46	14	29.57	291	265	P	V	
		2483.52	50.08	-3.92	54	38.19	27.46	14	29.57	291	265	A	V	
													V	
													V	
802.11n HT20 CH 13 2472MHz	*	2472	97.09	-	-	85.21	27.46	13.99	29.57	103	228	P	H	
	*	2472	89.54	-	-	77.66	27.46	13.99	29.57	103	228	A	H	
		2483.52	64.33	-9.67	74	52.44	27.46	14	29.57	103	228	P	H	
		2483.52	52.22	-1.78	54	40.33	27.46	14	29.57	103	228	A	H	
														H
														H
	*	2472	93.81	-	-	81.93	27.46	13.99	29.57	285	267	P	V	
	*	2472	85.94	-	-	74.06	27.46	13.99	29.57	285	267	A	V	
		2484	61.76	-12.24	74	49.87	27.46	14	29.57	285	267	P	V	
		2483.56	50.04	-3.96	54	38.15	27.46	14	29.57	285	267	A	V	
													V	
													V	
Remark	1. No other spurious found. 2. All results are PASS against Peak and Average limit line.													



**2.4GHz 2400~2483.5MHz
WIFI 802.11n HT20 (Harmonic @ 3m)**

WIFI Ant. 2+4	Note	Frequency (MHz)	Level (dBμV/m)	Over Limit (dB)	Limit Line (dBμV/m)	Read Level (dBμV)	Antenna Factor (dB/m)	Path Loss (dB)	Preamp Factor (dB)	Ant Pos (cm)	Table Pos (deg)	Peak Avg. (P/A)	Pol. (H/V)	
802.11n HT20 CH 01 2412MHz		4824	37.63	-36.37	74	57.5	31.26	6.42	57.55	100	0	P	H	
													H	
													H	
													H	
			4824	37.29	-36.71	74	57.16	31.26	6.42	57.55	100	0	P	V
														V
														V
802.11n HT20 CH 06 2437MHz		4874	37.33	-36.67	74	56.86	31.36	6.56	57.45	100	0	P	H	
		7311	58.87	-15.13	74	71.76	36.18	8.2	57.27	100	142	P	H	
		7311	47.53	-6.47	54	60.42	36.18	8.2	57.27	100	142	A	H	
													H	
			4874	39.67	-34.33	74	59.2	31.36	6.56	57.45	100	0	P	V
			7311	62.46	-11.54	74	75.35	36.18	8.2	57.27	246	280	P	V
			7311	52.13	-1.87	54	65.02	36.18	8.2	57.27	246	280	A	V
													V	
802.11n HT20 CH 11 2462MHz		4924	38.65	-35.35	74	57.84	31.46	6.7	57.35	100	0	P	H	
		7386	59.65	-14.35	74	72.5	36.37	8.14	57.36	108	249	P	H	
		7386	47.66	-6.34	54	60.51	36.37	8.14	57.36	108	249	A	H	
													H	
			4924	39.21	-34.79	74	58.4	31.46	6.7	57.35	100	0	P	V
			7386	61.31	-12.69	74	74.16	36.37	8.14	57.36	272	300	P	V
			7386	49.82	-4.18	54	62.67	36.37	8.14	57.36	272	300	A	V
													V	
Remark	1. No other spurious found. 2. All results are PASS against Peak and Average limit line.													



WiFi Ant. 2+4	Note	Frequency (MHz)	Level (dBμV/m)	Over Limit (dB)	Limit Line (dBμV/m)	Read Level (dBμV)	Antenna Factor (dB/m)	Path Loss (dB)	Preamp Factor (dB)	Ant Pos (cm)	Table Pos (deg)	Peak Avg. (P/A)	Pol. (H/V)
802.11n HT20 CH 12 2467MHz		4934	39.15	-34.85	74	58.29	31.46	6.73	57.33	100	0	P	H
		7401	45.63	-28.37	74	58.47	36.41	8.13	57.38	100	0	P	H
													H
													H
		4934	38.27	-35.73	74	57.41	31.46	6.73	57.33	100	0	P	V
		7401	48.78	-25.22	74	61.62	36.41	8.13	57.38	100	0	P	V
802.11n HT20 CH 13 2472MHz		4944	38.03	-35.97	74	57.08	31.5	6.76	57.31	100	0	P	H
		7416	42.95	-31.05	74	55.78	36.41	8.16	57.4	100	0	P	H
													H
													H
		4944	38.63	-35.37	74	57.68	31.5	6.76	57.31	100	0	P	V
		7416	42.85	-31.15	74	55.68	36.41	8.16	57.4	100	0	P	V
Remark	1. No other spurious found.												
	2. All results are PASS against Peak and Average limit line.												



Emission below 1GHz
2.4GHz WIFI 802.11b (LF)

WIFI	Note	Frequency	Level	Over	Limit	Read	Antenna	Path	Preamp	Ant	Table	Peak	Pol.	
Ant.				Limit	Line	Level	Factor	Loss	Factor	Pos	Pos	Avg.		
2+4		(MHz)	(dBμV/m)	(dB)	(dBμV/m)	(dBμV)	(dB/m)	(dB)	(dB)	(cm)	(deg)	(P/A)	(H/V)	
2.4GHz 802.11b LF		160.95	29.66	-13.84	43.5	44.74	16.01	1.08	32.17	-	-	P	H	
		182.29	28.03	-15.47	43.5	44.5	14.5	1.18	32.15	-	-	P	H	
		201.69	30.35	-13.15	43.5	46.58	14.67	1.24	32.14	-	-	P	H	
		281.23	28.38	-17.62	46	40.67	18.45	1.41	32.15	-	-	P	H	
		732.28	29.51	-16.49	46	31.85	27.39	2.3	32.03	-	-	P	H	
		944.71	33.76	-12.24	46	31.94	30.19	2.66	31.03	100	0	P	H	
														H
														H
														H
														H
														H
														H
			31.94	32.41	-7.59	40	40.6	23.64	0.46	32.29	-	-	P	V
			45.52	33.85	-6.15	40	49.28	16.34	0.52	32.29	100	0	P	V
			96.93	28.29	-15.21	43.5	44.32	15.38	0.8	32.21	-	-	P	V
			128.94	31.53	-11.97	43.5	45.45	17.29	0.98	32.19	-	-	P	V
			858.38	33.07	-12.93	46	33.26	28.8	2.62	31.61	-	-	P	V
			943.74	33.62	-12.38	46	31.86	30.15	2.65	31.04	-	-	P	V
														V
														V
													V	
													V	
													V	
													V	
Remark	1. No other spurious found. 2. All results are PASS against limit line.													



<Wireless charging Mode>

2.4GHz 2400~2483.5MHz

WIFI 802.11b (Band Edge @ 3m)

WIFI Ant. 2+4	Note	Frequency (MHz)	Level (dBμV/m)	Over Limit (dB)	Limit Line (dBμV/m)	Read Level (dBμV)	Antenna Factor (dB/m)	Path Loss (dB)	Preamp Factor (dB)	Ant Pos (cm)	Table Pos (deg)	Peak Avg. (P/A)	Pol. (H/V)
802.11b CH 12 2467MHz	*	2467	105.55	-	-	93.72	27.41	13.99	29.57	100	114	P	H
	*	2467	102.4	-	-	90.57	27.41	13.99	29.57	100	114	A	H
		2483.92	57.39	-16.61	74	45.5	27.46	14	29.57	100	114	P	H
		2484.36	50.27	-3.73	54	38.38	27.46	14	29.57	100	114	A	H
													H
													H
	*	2467	105.3	-	-	93.47	27.41	13.99	29.57	250	89	P	V
	*	2467	102.06	-	-	90.23	27.41	13.99	29.57	250	89	A	V
		2483.6	56.17	-17.83	74	44.28	27.46	14	29.57	250	89	P	V
		2484.32	49.41	-4.59	54	37.52	27.46	14	29.57	250	89	A	V
													V
												V	
Remark	1. No other spurious found. 2. All results are PASS against Peak and Average limit line.												

2.4GHz 2400~2483.5MHz

WIFI 802.11b (Harmonic @ 3m)

WIFI Ant. 2+4	Note	Frequency (MHz)	Level (dBμV/m)	Over Limit (dB)	Limit Line (dBμV/m)	Read Level (dBμV)	Antenna Factor (dB/m)	Path Loss (dB)	Preamp Factor (dB)	Ant Pos (cm)	Table Pos (deg)	Peak Avg. (P/A)	Pol. (H/V)
802.11b CH 12 2467MHz		4934	38.39	-35.61	74	57.53	31.46	6.73	57.33	100	0	P	H
		7401	54.8	-19.2	74	67.64	36.41	8.13	57.38	200	110	P	H
		7401	50.7	-3.3	54	63.54	36.41	8.13	57.38	200	110	A	H
													H
		4934	39.44	-34.56	74	58.58	31.46	6.73	57.33	100	0	P	V
		7401	52.82	-21.18	74	65.66	36.41	8.13	57.38	100	111	P	V
		7401	48.77	-5.23	54	61.61	36.41	8.13	57.38	100	111	A	V
													V
Remark	1. No other spurious found. 2. All results are PASS against Peak and Average limit line.												



Emission below 1GHz
2.4GHz WIFI 802.11b (LF)

WIFI Ant. 2+4	Note	Frequency (MHz)	Level (dBμV/m)	Over Limit (dB)	Limit Line (dBμV/m)	Read Level (dBμV)	Antenna Factor (dB/m)	Path Loss (dB)	Preamp Factor (dB)	Ant Pos (cm)	Table Pos (deg)	Peak Avg. (P/A)	Pol. (H/V)
		30.97	22.62	-17.38	40	30.14	24.31	0.46	32.29	-	-	P	H
		127.97	32.94	-10.56	43.5	46.96	17.2	0.97	32.19	100	0	P	H
		181.32	31.11	-12.39	43.5	47.59	14.5	1.17	32.15	-	-	P	H
		709.97	29.39	-16.61	46	32.8	26.4	2.26	32.07	-	-	P	H
		800.18	33.52	-12.48	46	35.48	27.5	2.43	31.89	-	-	P	H
		952.47	33.47	-12.53	46	31.22	30.55	2.66	30.96	-	-	P	H
													H
													H
													H
													H
													H
													H
2.4GHz													H
802.11b													H
LF		39.7	33.3	-6.7	40	45.46	19.61	0.52	32.29	100	0	P	V
		62.98	29.69	-10.31	40	49.84	11.5	0.62	32.27	-	-	P	V
		121.18	30.54	-12.96	43.5	44.67	17.12	0.95	32.2	-	-	P	V
		569.32	31.06	-14.94	46	35.63	25.61	2.04	32.22	-	-	P	V
		759.44	32.61	-13.39	46	34.43	27.8	2.35	31.97	-	-	P	V
		954.41	34.14	-11.86	46	31.83	30.59	2.67	30.95	-	-	P	V
													V
													V
													V
													V
													V
													V
													V
													V
Remark	3. No other spurious found. 4. All results are PASS against limit line.												



Note symbol

*	Fundamental Frequency which can be ignored. However, the level of any unwanted emissions shall not exceed the level of the fundamental frequency.
!	Test result is over limit line.
P/A	Peak or Average
H/V	Horizontal or Vertical



A calculation example for radiated spurious emission is shown as below:

WIFI	Note	Frequency	Level	Over	Limit	Read	Antenna	Path	Preamp	Ant	Table	Peak	Pol.
Ant.				Limit	Line	Level	Factor	Loss	Factor	Pos	Pos	Avg.	
2+4		(MHz)	(dBμV/m)	(dB)	(dBμV/m)	(dBμV)	(dB/m)	(dB)	(dB)	(cm)	(deg)	(P/A)	(H/V)
802.11b		2390	55.45	-18.55	74	54.51	32.22	4.58	35.86	103	308	P	H
CH 01													
2412MHz		2390	43.54	-10.46	54	42.6	32.22	4.58	35.86	103	308	A	H

1. Path Loss(dB) = Cable loss(dB) + Filter loss(dB) + Attenuator loss(dB)
2. Level(dBμV/m) =
Antenna Factor(dB/m) + Path Loss(dB) + Read Level(dBμV) - Preamp Factor(dB)
3. Over Limit(dB) = Level(dBμV/m) – Limit Line(dBμV/m)

For Peak Limit @ 2390MHz:

1. Level(dBμV/m)
= Antenna Factor(dB/m) + Path Loss(dB) + Read Level(dBμV) - Preamp Factor(dB)
= 32.22(dB/m) + 4.58(dB) + 54.51(dBμV) – 35.86 (dB)
= 55.45 (dBμV/m)
2. Over Limit(dB)
= Level(dBμV/m) – Limit Line(dBμV/m)
= 55.45(dBμV/m) – 74(dBμV/m)
= -18.55(dB)

For Average Limit @ 2390MHz:

1. Level(dBμV/m)
= Antenna Factor(dB/m) + Path Loss(dB) + Read Level(dBμV) - Preamp Factor(dB)
= 32.22(dB/m) + 4.58(dB) + 42.6(dBμV) – 35.86 (dB)
= 43.54 (dBμV/m)
2. Over Limit(dB)
= Level(dBμV/m) – Limit Line(dBμV/m)
= 43.54(dBμV/m) – 54(dBμV/m)
= -10.46(dB)

Both peak and average measured complies with the limit line, so test result is “PASS”.



Appendix D. Radiated Spurious Emission Plots

Test Engineer :	JC Liang and Wilson Wu	Temperature :	25.1~25.2°C
		Relative Humidity :	50~52%

Note symbol

-L	Low channel location
-R	High channel location

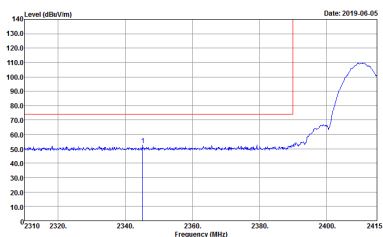
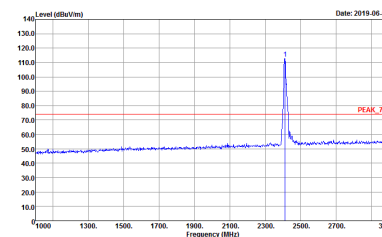
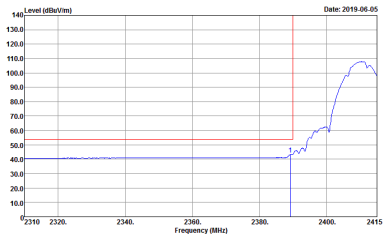
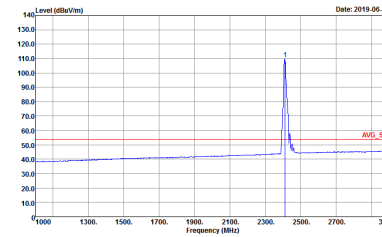

2.4GHz 2400~2483.5MHz
WIFI 802.11b (Band Edge @ 3m)

WIFI	2.4GHz 2400~2483.5MHz Band Edge @ 3m	
ANT	802.11b CH01 2412MHz	
2+4	Horizontal	Fundamental
Peak	 <p>Site : 03CH13-HY Condition : PEAK_BE_74 3m HORN_91200_1241 HORIZONTAL Detector : Peak Project : 8N0620-05 Mode : 13 Power : 23</p>	 <p>Site : 03CH13-HY Condition : PEAK_74 3m HORN_91200_1241 HORIZONTAL Detector : Peak Project : 8N0620-05 Mode : 13 Power : 23</p>
Avg.	 <p>Site : 03CH13-HY Condition : AVG_BE_54 3m HORN_91200_1241 HORIZONTAL Detector : Peak Project : 8N0620-05 Mode : 13 Power : 23</p>	 <p>Site : 03CH13-HY Condition : AVG_54 3m HORN_91200_1241 HORIZONTAL Detector : Peak Project : 8N0620-05 Mode : 13 Power : 23</p>

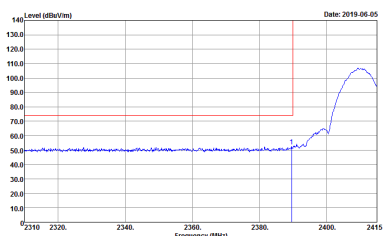
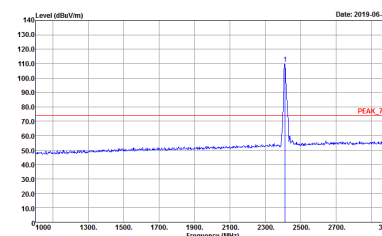
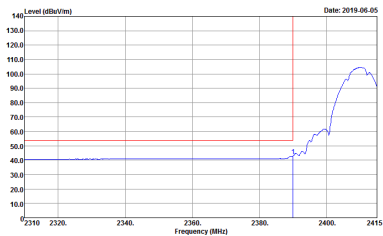
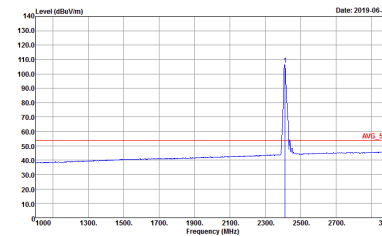

WIFI	2.4GHz 2400~2483.5MHz Band Edge @ 3m	
ANT	802.11b CH01 2412MHz	
2+4	Vertical	Fundamental
Peak	 <p>Site : 03CH13-HY Condition : PEAK_BE_74 3m HORN_91200_1241 VERTICAL RBW:1000.000kHz VBW:3000.000kHz SWT:Auto Detector : Peak Project : 8N0620-05 Mode : 13 Power : 23</p>	 <p>Site : 03CH13-HY Condition : PEAK_74 3m HORN_91200_1241 VERTICAL RBW:1000.000kHz VBW:3000.000kHz SWT:Auto Detector : Peak Project : 8N0620-05 Mode : 13 Power : 23</p>
Avg.	 <p>Site : 03CH13-HY Condition : AVG_BE_54 3m HORN_91200_1241 VERTICAL RBW:1000.000kHz VBW:0.010kHz SWT:Auto Detector : Peak Project : 8N0620-05 Mode : 13 Power : 23</p>	 <p>Site : 03CH13-HY Condition : AVG_54 3m HORN_91200_1241 VERTICAL RBW:1000.000kHz VBW:0.010kHz SWT:Auto Detector : Peak Project : 8N0620-05 Mode : 13 Power : 23</p>

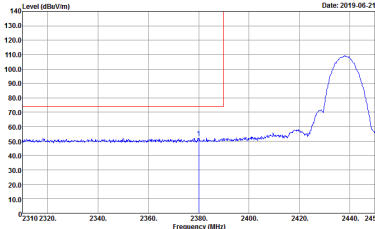
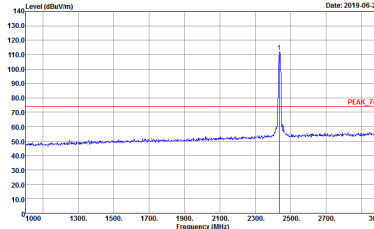
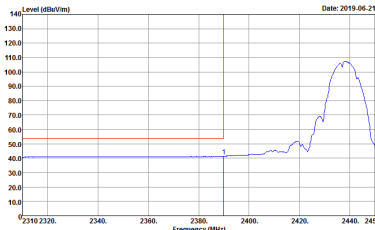
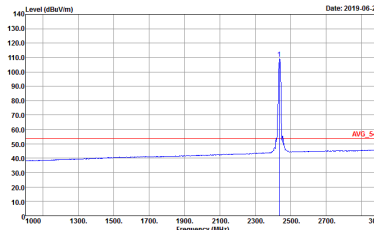

WIFI	2.4GHz 2400~2483.5MHz Band Edge @ 3m	
ANT	802.11b CH06 2437MHz - L	
2+4	Horizontal	Fundamental
Peak	 <p>Site : 03CH13-HY Condition : PEAK_BE_74 3m HORN_91200_1241 HORIZONTAL RBW:1000.000kHz VBW:3000.000kHz SWT:Auto Detector : Peak Project : 8N0620-05 Mode : 14 Power : 20</p>	 <p>Site : 03CH13-HY Condition : PEAK_74 3m HORN_91200_1241 HORIZONTAL RBW:1000.000kHz VBW:3000.000kHz SWT:Auto Detector : Peak Project : 8N0620-05 Mode : 14 Power : 20</p>
Avg.	 <p>Site : 03CH13-HY Condition : AVG_BE_54 3m HORN_91200_1241 HORIZONTAL RBW:1000.000kHz VBW:0.010kHz SWT:Auto Detector : Peak Project : 8N0620-05 Mode : 14 Power : 20</p>	 <p>Site : 03CH13-HY Condition : AVG_54 3m HORN_91200_1241 HORIZONTAL RBW:1000.000kHz VBW:0.010kHz SWT:Auto Detector : Peak Project : 8N0620-05 Mode : 14 Power : 20</p>

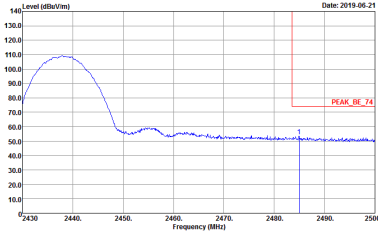
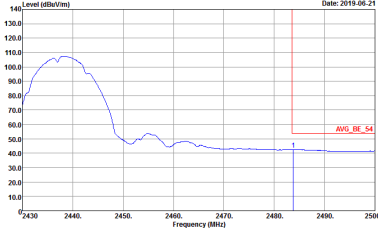

WIFI	2.4GHz 2400~2483.5MHz Band Edge @ 3m	
ANT	802.11b CH06 2437MHz - R	
2+4	Horizontal	Fundamental
<p>Peak</p>	 <p>Site : 03CH13-HY Condition : PEAK_BE_74 3m HORN_9120D_1241 HORIZONTAL RBW:1000.000kHz VBW:3000.000kHz SWT:Auto Detector : Peak Project : BN0620-05 Mode : 14 Power : 20</p>	<p>Left blank</p>
<p>Avg.</p>	 <p>Site : 03CH13-HY Condition : AVG_BE_54 3m HORN_9120D_1241 HORIZONTAL RBW:1000.000kHz VBW:0.0100kHz SWT:Auto Detector : Peak Project : BN0620-05 Mode : 14 Power : 20</p>	<p>Left blank</p>

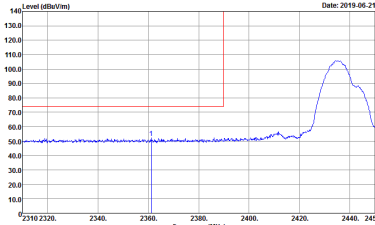
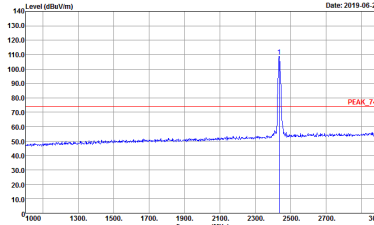
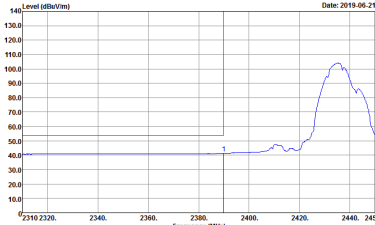
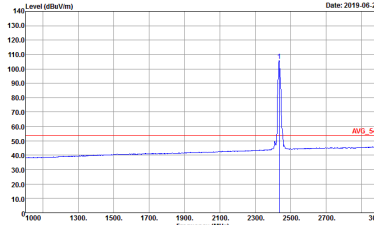

WIFI	2.4GHz 2400~2483.5MHz Band Edge @ 3m	
ANT	802.11b CH06 2437MHz - L	
2+4	Vertical	Fundamental
Peak	 <p>Site : 03CH13-HY Condition : PEAK_BE_74 3m HORN_91200_1241 VERTICAL Detector : Peak Project : 8N0620-05 Mode : 14 Power : 20</p>	 <p>Site : 03CH13-HY Condition : PEAK_74 3m HORN_91200_1241 VERTICAL Detector : Peak Project : 8N0620-05 Mode : 14 Power : 20</p>
Avg.	 <p>Site : 03CH13-HY Condition : AVG_BE_54 3m HORN_91200_1241 VERTICAL Detector : Peak Project : 8N0620-05 Mode : 14 Power : 20</p>	 <p>Site : 03CH13-HY Condition : AVG_54 3m HORN_91200_1241 VERTICAL Detector : Peak Project : 8N0620-05 Mode : 14 Power : 20</p>

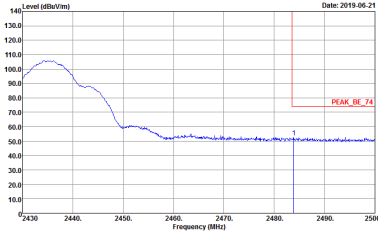
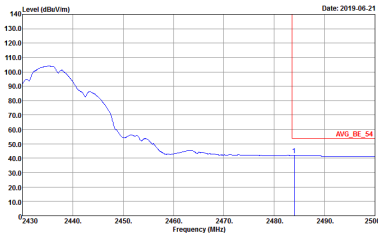

WIFI	2.4GHz 2400~2483.5MHz Band Edge @ 3m	
ANT	802.11b CH06 2437MHz - R	
2+4	Vertical	Fundamental
<p>Peak</p>	 <p>Site : 03CH13-HY Condition : PEAK_BE_74 3m HORN_9120D_1241 VERTICAL RBW:1000.000kHz VBW:3000.000kHz SWF:Auto Detector : Peak Project : BN0620-05 Mode : 14 Power : 20</p>	<p>Left blank</p>
<p>Avg.</p>	 <p>Site : 03CH13-HY Condition : AVG_BE_54 3m HORN_9120D_1241 VERTICAL RBW:1000.000kHz VBW:0.0100kHz SWF:Auto Detector : Peak Project : BN0620-05 Mode : 14 Power : 20</p>	<p>Left blank</p>

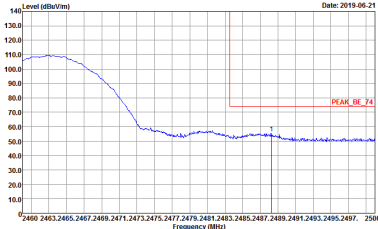
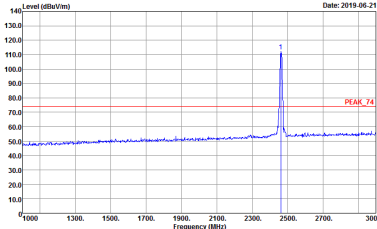
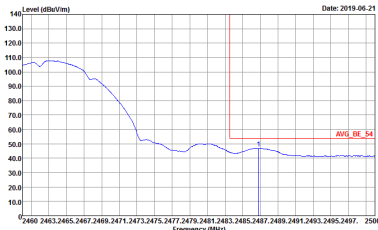
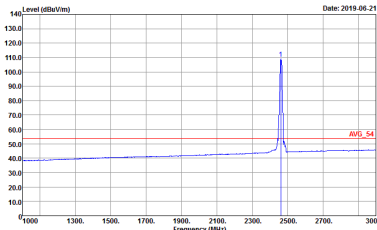

WIFI	2.4GHz 2400~2483.5MHz Band Edge @ 3m	
ANT	802.11b CH11 2462MHz	
2+4	Horizontal	Fundamental
Peak	 <p>Site : 03CH13-HY Condition : PEAK_BE_74 3m HORN_91200_1241 HORIZONTAL RBW:1000.000KHz VBW:3000.000KHz SWT:Auto Detector : Peak Project : BN0620-05 Mode : 15 Power : 20</p>	 <p>Site : 03CH13-HY Condition : PEAK_74 3m HORN_91200_1241 HORIZONTAL RBW:1000.000KHz VBW:3000.000KHz SWT:Auto Detector : Peak Project : BN0620-05 Mode : 15 Power : 20</p>
Avg.	 <p>Site : 03CH13-HY Condition : AVG_BE_54 3m HORN_91200_1241 HORIZONTAL RBW:1000.000KHz VBW:0.010KHz SWT:Auto Detector : Peak Project : BN0620-05 Mode : 15 Power : 20</p>	 <p>Site : 03CH13-HY Condition : AVG_54 3m HORN_91200_1241 HORIZONTAL RBW:1000.000KHz VBW:0.010KHz SWT:Auto Detector : Peak Project : BN0620-05 Mode : 15 Power : 20</p>

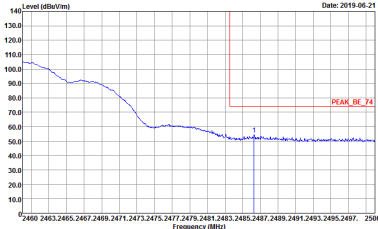
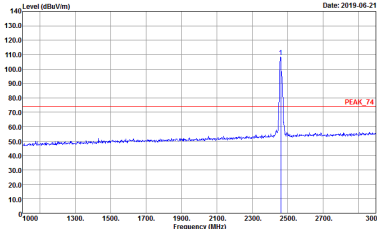
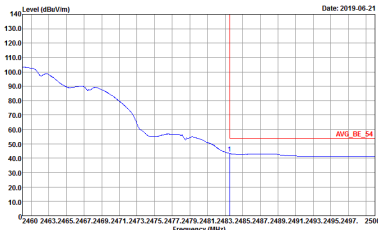
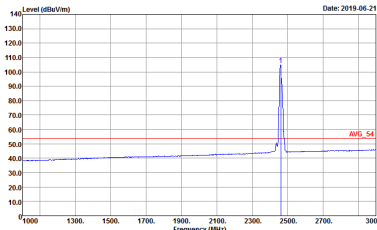

WIFI	2.4GHz 2400~2483.5MHz Band Edge @ 3m	
ANT	802.11b CH11 2462MHz	
2+4	Vertical	Fundamental
<p>Peak</p>	 <p>Site : 03CH13-HY Condition : PEAK_BE_74 3m HORN_91200_1241 VERTICAL RBW:1000.000KHz VBW:3000.000KHz SWT:Auto Detector : Peak Project : BN0620-05 Mode : 15 Power : 20</p>	 <p>Site : 03CH13-HY Condition : PEAK_74 3m HORN_91200_1241 VERTICAL RBW:1000.000KHz VBW:3000.000KHz SWT:Auto Detector : Peak Project : BN0620-05 Mode : 15 Power : 20</p>
<p>Avg.</p>	 <p>Site : 03CH13-HY Condition : AVG_BE_54 3m HORN_91200_1241 VERTICAL RBW:1000.000KHz VBW:0.010KHz SWT:Auto Detector : Peak Project : BN0620-05 Mode : 15 Power : 20</p>	 <p>Site : 03CH13-HY Condition : AVG_54 3m HORN_91200_1241 VERTICAL RBW:1000.000KHz VBW:0.010KHz SWT:Auto Detector : Peak Project : BN0620-05 Mode : 15 Power : 20</p>

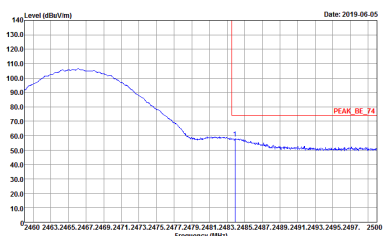
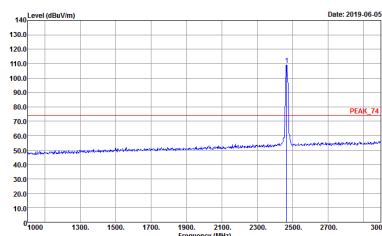
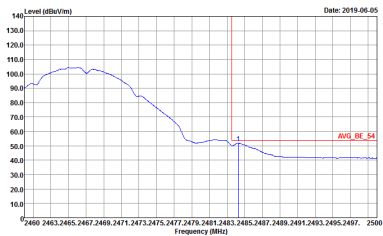
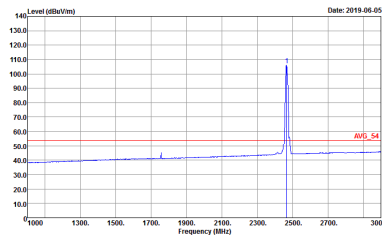

WIFI	2.4GHz 2400~2483.5MHz Band Edge @ 3m	
ANT	802.11b CH12 2467MHz	
2+4	Horizontal	Fundamental
<p>Peak</p>	 <p>Site : 03CH13-HY Condition : PEAK_BE_74 3m HORN_91200_1241 HORIZONTAL RBW:1000.000KHz VBW:3000.000KHz SWT:Auto Detector : Peak Project : BN0620-05 Mode : 16 Power : 17</p>	 <p>Site : 03CH13-HY Condition : PEAK_74 3m HORN_91200_1241 HORIZONTAL RBW:1000.000KHz VBW:3000.000KHz SWT:Auto Detector : Peak Project : BN0620-05 Mode : 16 Power : 17</p>
<p>Avg.</p>	 <p>Site : 03CH13-HY Condition : AVG_BE_54 3m HORN_91200_1241 HORIZONTAL RBW:1000.000KHz VBW:0.010KHz SWT:Auto Detector : Peak Project : BN0620-05 Mode : 16 Power : 17</p>	 <p>Site : 03CH13-HY Condition : AVG_54 3m HORN_91200_1241 HORIZONTAL RBW:1000.000KHz VBW:0.010KHz SWT:Auto Detector : Peak Project : BN0620-05 Mode : 16 Power : 17</p>

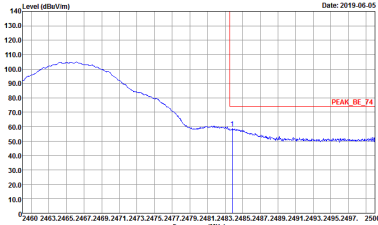
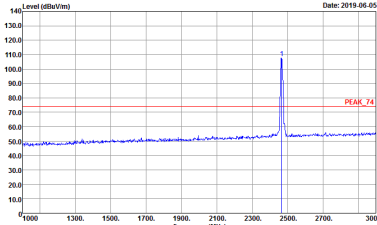
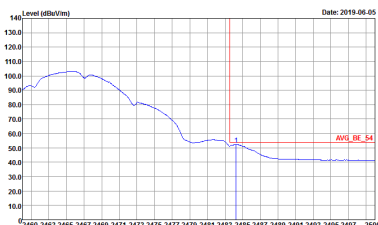
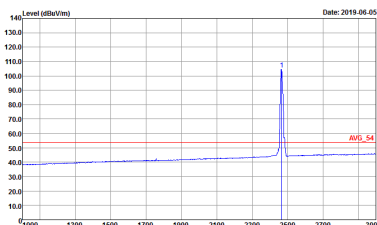

WIFI	2.4GHz 2400~2483.5MHz Band Edge @ 3m	
ANT	802.11b CH12 2467MHz	
2+4	Vertical	Fundamental
<p>Peak</p>	 <p>Site : 03CH13-HY Condition : PEAK_BE_74 3m HORN_91200_1241 VERTICAL RBW:1000.000KHz VBW:3000.000KHz SWT:Auto Detector : Peak Project : BN0620-05 Mode : 16 Power : 17</p>	 <p>Site : 03CH13-HY Condition : PEAK_74 3m HORN_91200_1241 VERTICAL RBW:1000.000KHz VBW:3000.000KHz SWT:Auto Detector : Peak Project : BN0620-05 Mode : 16 Power : 17</p>
<p>Avg.</p>	 <p>Site : 03CH13-HY Condition : AVG_BE_54 3m HORN_91200_1241 VERTICAL RBW:1000.000KHz VBW:0.010KHz SWT:Auto Detector : Peak Project : BN0620-05 Mode : 16 Power : 17</p>	 <p>Site : 03CH13-HY Condition : AVG_54 3m HORN_91200_1241 VERTICAL RBW:1000.000KHz VBW:0.010KHz SWT:Auto Detector : Peak Project : BN0620-05 Mode : 16 Power : 17</p>

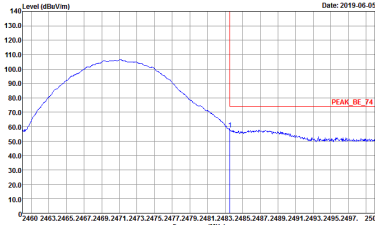
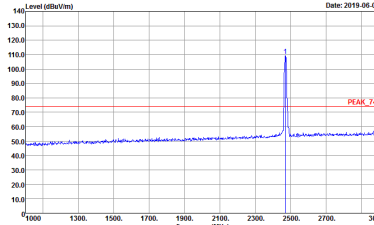
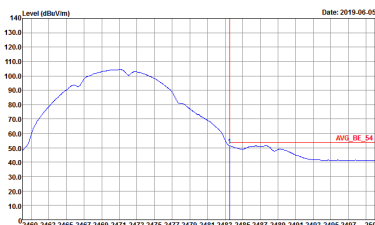
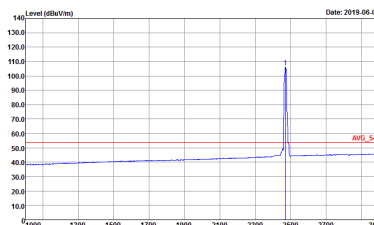

WIFI	2.4GHz 2400~2483.5MHz Band Edge @ 3m	
ANT	802.11b CH13 2472MHz	
2+4	Horizontal	Fundamental
<p>Peak</p>	 <p>Site : 03CH13-HY Condition : PEAK_BE_74 3m HORN_91200_1241 HORIZONTAL RBW:1000.000KHz VBW:3000.000KHz SWT:Auto Detector : Peak Project : 8N0620-05 Mode : 17 Power : 17</p>	 <p>Site : 03CH13-HY Condition : PEAK_74 3m HORN_91200_1241 HORIZONTAL RBW:1000.000KHz VBW:3000.000KHz SWT:Auto Detector : Peak Project : 8N0620-05 Mode : 17 Power : 17</p>
<p>Avg.</p>	 <p>Site : 03CH13-HY Condition : AVG_BE_54 3m HORN_91200_1241 HORIZONTAL RBW:1000.000KHz VBW:0.010KHz SWT:Auto Detector : Peak Project : 8N0620-05 Mode : 17 Power : 17</p>	 <p>Site : 03CH13-HY Condition : AVG_54 3m HORN_91200_1241 HORIZONTAL RBW:1000.000KHz VBW:0.010KHz SWT:Auto Detector : Peak Project : 8N0620-05 Mode : 17 Power : 17</p>

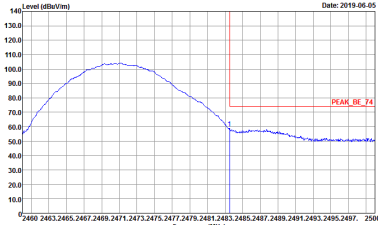
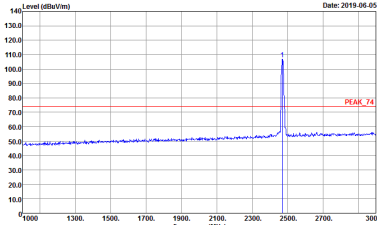
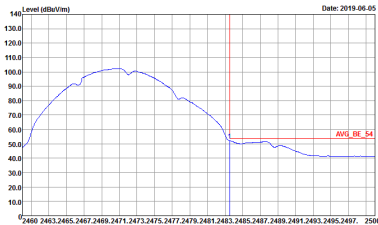
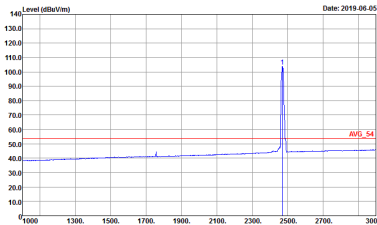

WIFI	2.4GHz 2400~2483.5MHz Band Edge @ 3m	
ANT	802.11b CH13 2472MHz	
2+4	Vertical	Fundamental
<p>Peak</p>	 <p>Site : 03CH13-HY Condition : PEAK_BE_74 3m HORN_91200_1241 VERTICAL RBW:1000.000KHz VBW:3000.000KHz SWT:Auto Detector : Peak Project : 8N0620-05 Mode : 17 Power : 17</p>	 <p>Site : 03CH13-HY Condition : PEAK_74 3m HORN_91200_1241 VERTICAL RBW:1000.000KHz VBW:3000.000KHz SWT:Auto Detector : Peak Project : 8N0620-05 Mode : 17 Power : 17</p>
<p>Avg.</p>	 <p>Site : 03CH13-HY Condition : AVG_BE_54 3m HORN_91200_1241 VERTICAL RBW:1000.000KHz VBW:0.010KHz SWT:Auto Detector : Peak Project : 8N0620-05 Mode : 17 Power : 17</p>	 <p>Site : 03CH13-HY Condition : AVG_54 3m HORN_91200_1241 VERTICAL RBW:1000.000KHz VBW:0.010KHz SWT:Auto Detector : Peak Project : 8N0620-05 Mode : 17 Power : 17</p>

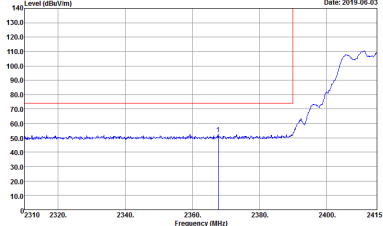
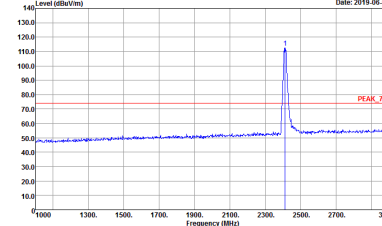
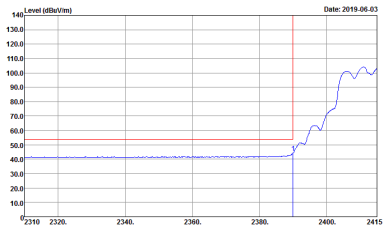
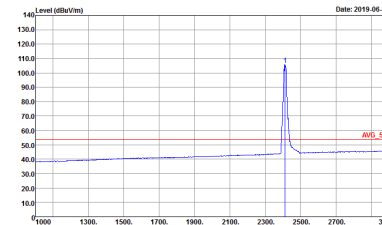

2.4GHz 2400~2483.5MHz
WIFI 802.11g (Band Edge @ 3m)

WIFI	2.4GHz 2400~2483.5MHz Band Edge @ 3m	
ANT	802.11g CH01 2412MHz	
2+4	Horizontal	Fundamental
Peak	 <p>Site : 03CH13-HY Condition : PEAK_BE_74 3m HORN_91200_1241 HORIZONTAL Detector : Peak Project : 8N0620-05 Mode : 18 Power : 19.5</p>	 <p>Site : 03CH13-HY Condition : PEAK_74 3m HORN_91200_1241 HORIZONTAL Detector : Peak Project : 8N0620-05 Mode : 18 Power : 19.5</p>
Avg.	 <p>Site : 03CH13-HY Condition : AVG_BE_54 3m HORN_91200_1241 HORIZONTAL Detector : Peak Project : 8N0620-05 Mode : 18 Power : 19.5</p>	 <p>Site : 03CH13-HY Condition : AVG_54 3m HORN_91200_1241 HORIZONTAL Detector : Peak Project : 8N0620-05 Mode : 18 Power : 19.5</p>



WIFI	2.4GHz 2400~2483.5MHz Band Edge @ 3m	
ANT	802.11g CH01 2412MHz	
2+4	Vertical	Fundamental
Peak	<p>Site : 03CH13-HY Condition : PEAK_BE_74 3m HORN_91200_1241 VERTICAL RBW:1000.000KHz VBW:3000.000KHz SWT:Auto Detector : Peak Project : 8N0620-05 Mode : 18 Power : 19.5</p>	<p>Site : 03CH13-HY Condition : PEAK_74 3m HORN_91200_1241 VERTICAL RBW:1000.000KHz VBW:3000.000KHz SWT:Auto Detector : Peak Project : 8N0620-05 Mode : 18 Power : 19.5</p>
Avg.	<p>Site : 03CH13-HY Condition : AVG_BE_54 3m HORN_91200_1241 VERTICAL RBW:1000.000KHz VBW:1000KHz SWT:Auto Detector : Peak Project : 8N0620-05 Mode : 18 Power : 19.5</p>	<p>Site : 03CH13-HY Condition : AVG_54 3m HORN_91200_1241 VERTICAL RBW:1000.000KHz VBW:1000KHz SWT:Auto Detector : Peak Project : 8N0620-05 Mode : 18 Power : 19.5</p>

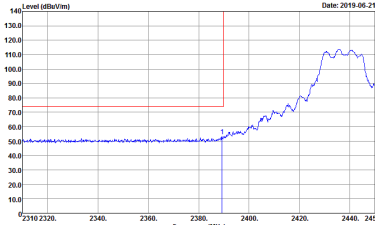
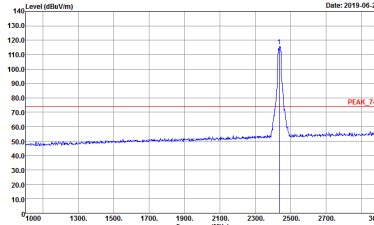
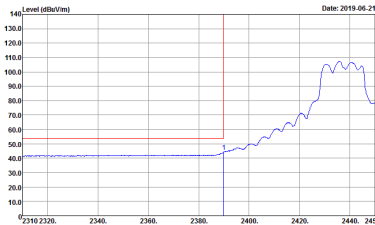
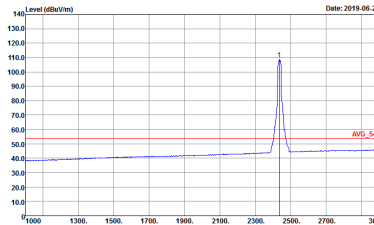

WIFI	2.4GHz 2400~2483.5MHz Band Edge @ 3m	
ANT	802.11g CH06 2437MHz - L	
2+4	Horizontal	Fundamental
Peak	 <p>Site : 03CH13-HY Condition : PEAK_BE_74 3m HORN_91200_1241 HORIZONTAL RBW:1000.000KHz VBW:3000.000KHz SWT:Auto Detector : Peak Project : 8N0620-05 Mode : 19 Power : 22</p>	 <p>Site : 03CH13-HY Condition : PEAK_74 3m HORN_91200_1241 HORIZONTAL RBW:1000.000KHz VBW:3000.000KHz SWT:Auto Detector : Peak Project : 8N0620-05 Mode : 19 Power : 22</p>
Avg.	 <p>Site : 03CH13-HY Condition : AVG_BE_54 3m HORN_91200_1241 HORIZONTAL RBW:1000.000KHz VBW:1000KHz SWT:Auto Detector : Peak Project : 8N0620-05 Mode : 19 Power : 22</p>	 <p>Site : 03CH13-HY Condition : AVG_54 3m HORN_91200_1241 HORIZONTAL RBW:1000.000KHz VBW:1000KHz SWT:Auto Detector : Peak Project : 8N0620-05 Mode : 19 Power : 22</p>

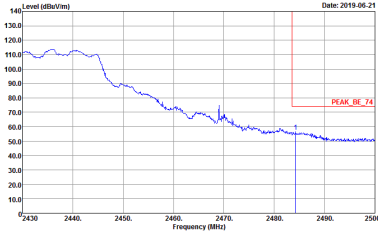
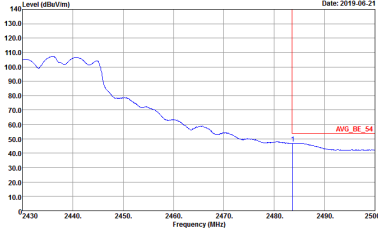

WIFI	2.4GHz 2400~2483.5MHz Band Edge @ 3m	
ANT	802.11g CH06 2437MHz - R	
2+4	Horizontal	Fundamental
<p>Peak</p>	 <p>Site : 03CH13-HY Condition : PEAK_BE_74 3m HORN_9120D_1241 HORIZONTAL Detector : Peak Project : BN0620-05 Mode : 19 Power : Z2</p>	<p>Left blank</p>
<p>Avg.</p>	 <p>Site : 03CH13-HY Condition : AVG_BE_54 3m HORN_9120D_1241 HORIZONTAL Detector : Peak Project : BN0620-05 Mode : 19 Power : Z2</p>	<p>Left blank</p>

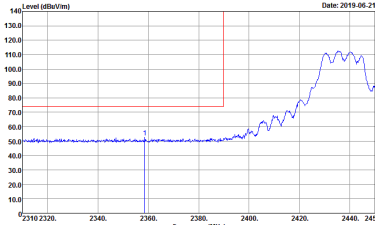
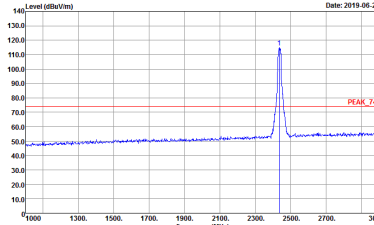
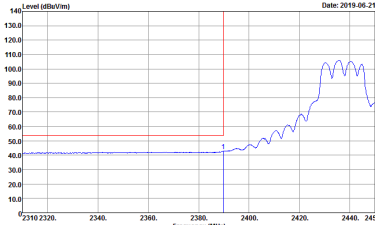
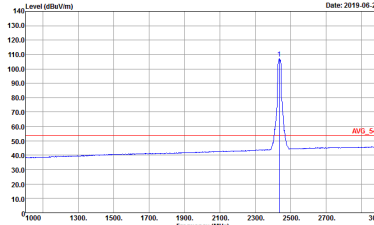

WIFI	2.4GHz 2400~2483.5MHz Band Edge @ 3m	
ANT	802.11g CH06 2437MHz - L	
2+4	Vertical	Fundamental
Peak	 <p>Site : 03CH13-HY Condition : PEAK_BE_74 3m HORN_91200_1241 VERTICAL RBW:1000.000KHz VBW:3000.000KHz SWT:Auto Detector : Peak Project : 8N0620-05 Mode : 19 Power : 22</p>	 <p>Site : 03CH13-HY Condition : PEAK_74 3m HORN_91200_1241 VERTICAL RBW:1000.000KHz VBW:3000.000KHz SWT:Auto Detector : Peak Project : 8N0620-05 Mode : 19 Power : 22</p>
Avg.	 <p>Site : 03CH13-HY Condition : AVG_BE_54 3m HORN_91200_1241 VERTICAL RBW:1000.000KHz VBW:1000KHz SWT:Auto Detector : Peak Project : 8N0620-05 Mode : 19 Power : 22</p>	 <p>Site : 03CH13-HY Condition : AVG_54 3m HORN_91200_1241 VERTICAL RBW:1000.000KHz VBW:1000KHz SWT:Auto Detector : Peak Project : 8N0620-05 Mode : 19 Power : 22</p>

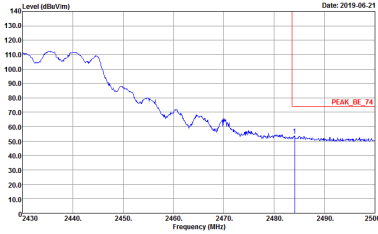
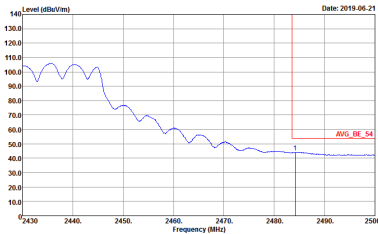

WIFI	2.4GHz 2400~2483.5MHz Band Edge @ 3m	
ANT	802.11g CH06 2437MHz - R	
2+4	Vertical	Fundamental
<p>Peak</p>	 <p>Site : 03CH13-HY Condition : PEAK_BE_74 3m HORN_9120D_1241 VERTICAL Detector : Peak Project : BN0620-05 Mode : 19 Power : Z2</p>	<p>Left Blank</p>
<p>Avg.</p>	 <p>Site : 03CH13-HY Condition : AVG_BE_54 3m HORN_9120D_1241 VERTICAL Detector : Peak Project : BN0620-05 Mode : 19 Power : Z2</p>	<p>Left Blank</p>

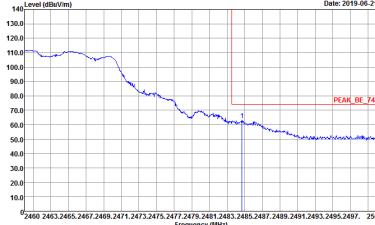
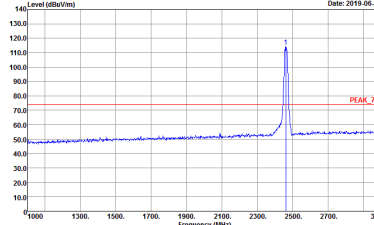
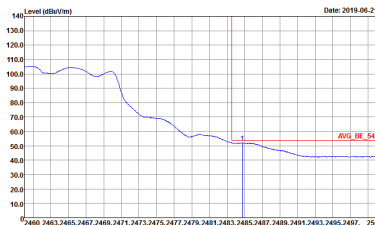
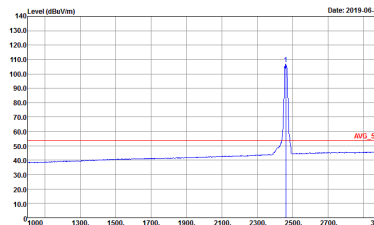

WIFI	2.4GHz 2400~2483.5MHz Band Edge @ 3m	
ANT	802.11g CH11 2462MHz	
2+4	Horizontal	Fundamental
<p>Peak</p>	 <p>Site : 03CH13-HY Condition : PEAK_BE_74 3m HORN_91200_1241 HORIZONTAL RBW:1000.000KHz VBW:3000.000KHz SWT:Auto Detector : Peak Project : BN0620-05 Mode : 20 Power : 19</p>	 <p>Site : 03CH13-HY Condition : PEAK_74 3m HORN_91200_1241 HORIZONTAL RBW:1000.000KHz VBW:3000.000KHz SWT:Auto Detector : Peak Project : BN0620-05 Mode : 20 Power : 19</p>
<p>Avg.</p>	 <p>Site : 03CH13-HY Condition : AVG_BE_54 3m HORN_91200_1241 HORIZONTAL RBW:1000.000KHz VBW:1000KHz SWT:Auto Detector : Peak Project : BN0620-05 Mode : 20 Power : 19</p>	 <p>Site : 03CH13-HY Condition : AVG_54 3m HORN_91200_1241 HORIZONTAL RBW:1000.000KHz VBW:1000KHz SWT:Auto Detector : Peak Project : BN0620-05 Mode : 20 Power : 19</p>

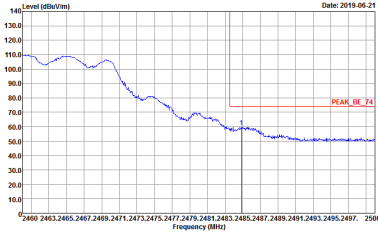
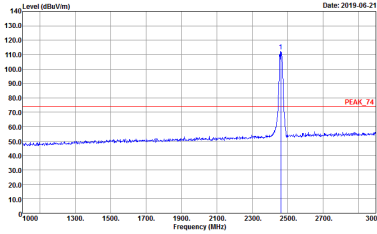
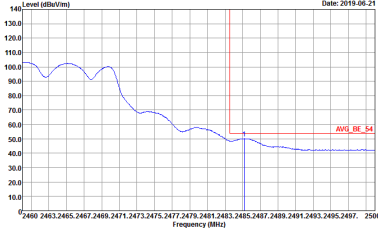
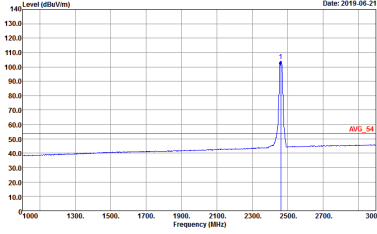

WIFI	2.4GHz 2400~2483.5MHz Band Edge @ 3m	
ANT	802.11g CH11 2462MHz	
2+4	Vertical	Fundamental
<p>Peak</p>	 <p>Site : 03CH13-HY Condition : PEAK_BE_74 3m HORN_91200_1241 VERTICAL RBW:1000.000KHz VBW:3000.000KHz SWT:Auto Detector : Peak Project : BN0620-05 Mode : 20 Power : 19</p>	 <p>Site : 03CH13-HY Condition : PEAK_74 3m HORN_91200_1241 VERTICAL RBW:1000.000KHz VBW:3000.000KHz SWT:Auto Detector : Peak Project : BN0620-05 Mode : 20 Power : 19</p>
<p>Avg.</p>	 <p>Site : 03CH13-HY Condition : AVG_BE_54 3m HORN_91200_1241 VERTICAL RBW:1000.000KHz VBW:1000KHz SWT:Auto Detector : Peak Project : BN0620-05 Mode : 20 Power : 19</p>	 <p>Site : 03CH13-HY Condition : AVG_54 3m HORN_91200_1241 VERTICAL RBW:1000.000KHz VBW:1000KHz SWT:Auto Detector : Peak Project : BN0620-05 Mode : 20 Power : 19</p>

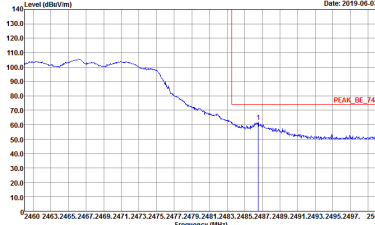
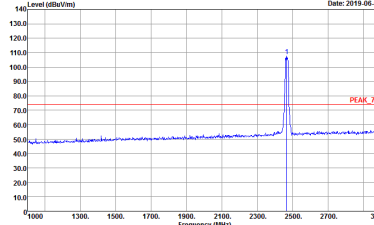
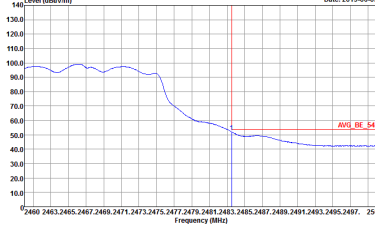
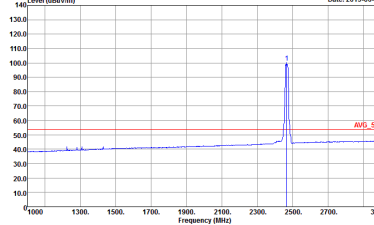

WIFI	2.4GHz 2400~2483.5MHz Band Edge @ 3m	
ANT	802.11g CH12 2467MHz	
2+4	Horizontal	Fundamental
Peak	 <p>Site : 03CH13-HY Condition : PEAK_BE_74 3m HORN_91200_1241 HORIZONTAL RBW:1000.000KHz VBW:3000.000KHz SWT:Auto Detector : Peak Project : 8N0620-05 Mode : Z1 Power : 14.5</p>	 <p>Site : 03CH13-HY Condition : PEAK_74 3m HORN_91200_1241 HORIZONTAL RBW:1000.000KHz VBW:3000.000KHz SWT:Auto Detector : Peak Project : 8N0620-05 Mode : Z1 Power : 14.5</p>
Avg.	 <p>Site : 03CH13-HY Condition : AVG_BE_54 3m HORN_91200_1241 HORIZONTAL RBW:1000.000KHz VBW:1000KHz SWT:Auto Detector : Peak Project : 8N0620-05 Mode : Z1 Power : 14.5</p>	 <p>Site : 03CH13-HY Condition : AVG_54 3m HORN_91200_1241 HORIZONTAL RBW:1000.000KHz VBW:1000KHz SWT:Auto Detector : Peak Project : 8N0620-05 Mode : Z1 Power : 14.5</p>

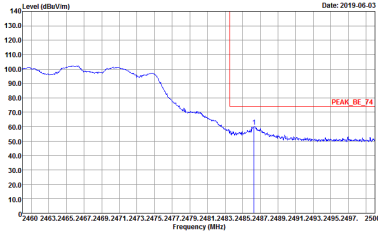
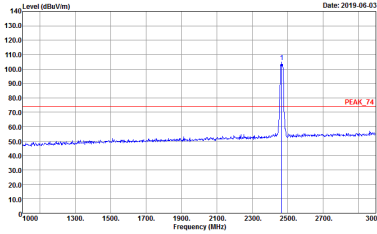
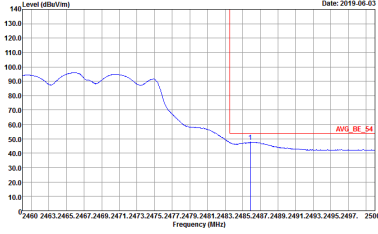
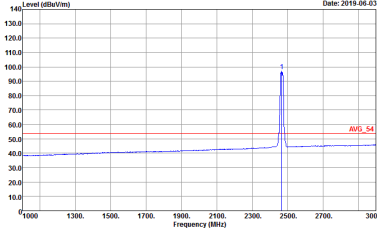

WIFI	2.4GHz 2400~2483.5MHz Band Edge @ 3m	
ANT	802.11g CH12 2467MHz	
2+4	Vertical	Fundamental
Peak	 <p>Site : 03CH13-HY Condition : PEAK_BE_74 3m HORN_91200_1241 VERTICAL RBW:1000.000KHz VBW:3000.000KHz SWT:Auto Detector : Peak Project : 8N0620-05 Mode : Z1 Power : 14.5</p>	 <p>Site : 03CH13-HY Condition : PEAK_74 3m HORN_91200_1241 VERTICAL RBW:1000.000KHz VBW:3000.000KHz SWT:Auto Detector : Peak Project : 8N0620-05 Mode : Z1 Power : 14.5</p>
Avg.	 <p>Site : 03CH13-HY Condition : AVG_BE_54 3m HORN_91200_1241 VERTICAL RBW:1000.000KHz VBW:1000KHz SWT:Auto Detector : Peak Project : 8N0620-05 Mode : Z1 Power : 14.5</p>	 <p>Site : 03CH13-HY Condition : AVG_54 3m HORN_91200_1241 VERTICAL RBW:1000.000KHz VBW:1000KHz SWT:Auto Detector : Peak Project : 8N0620-05 Mode : Z1 Power : 14.5</p>

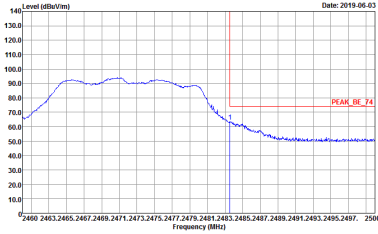
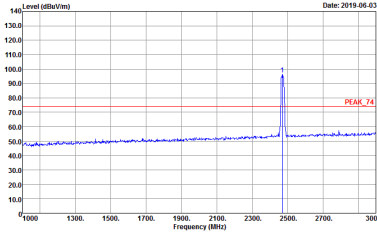
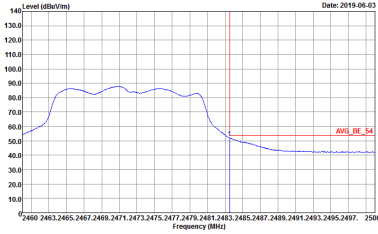
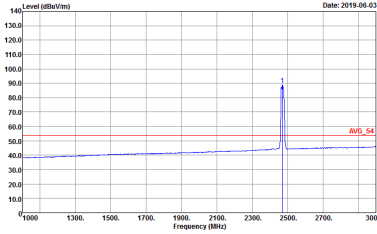

WIFI	2.4GHz 2400~2483.5MHz Band Edge @ 3m	
ANT	802.11g CH13 2472MHz	
2+4	Horizontal	Fundamental
<p>Peak</p>	 <p>Site : 03CH13-HY Condition : PEAK_BE_74 3m HORN_91200_1241 HORIZONTAL RBW:1000.000KHz VBW:3000.000KHz SWT:Auto Detector : Peak Project : 8N0620-05 Mode : Z2 Power : 3</p>	 <p>Site : 03CH13-HY Condition : PEAK_74 3m HORN_91200_1241 HORIZONTAL RBW:1000.000KHz VBW:3000.000KHz SWT:Auto Detector : Peak Project : 8N0620-05 Mode : Z2 Power : 3</p>
<p>Avg.</p>	 <p>Site : 03CH13-HY Condition : AVG_BE_54 3m HORN_91200_1241 HORIZONTAL RBW:1000.000KHz VBW:1000KHz SWT:Auto Detector : Peak Project : 8N0620-05 Mode : Z2 Power : 3</p>	 <p>Site : 03CH13-HY Condition : AVG_54 3m HORN_91200_1241 HORIZONTAL RBW:1000.000KHz VBW:1000KHz SWT:Auto Detector : Peak Project : 8N0620-05 Mode : Z2 Power : 3</p>



WIFI	2.4GHz 2400~2483.5MHz Band Edge @ 3m	
ANT	802.11g CH13 2472MHz	
2+4	Vertical	Fundamental
Peak	<p>Site : 03CH13-HY Condition : PEAK_BE_74 3m HORN_91200_1241 VERTICAL RBW:1000.000KHz VBW:3000.000KHz SWT:Auto Detector : Peak Project : 8N0620-05 Mode : Z2 Power : 3</p>	<p>Site : 03CH13-HY Condition : PEAK_74 3m HORN_91200_1241 VERTICAL RBW:1000.000KHz VBW:3000.000KHz SWT:Auto Detector : Peak Project : 8N0620-05 Mode : Z2 Power : 3</p>
Avg.	<p>Site : 03CH13-HY Condition : AVG_BE_54 3m HORN_91200_1241 VERTICAL RBW:1000.000KHz VBW:1000KHz SWT:Auto Detector : Peak Project : 8N0620-05 Mode : Z2 Power : 3</p>	<p>Site : 03CH13-HY Condition : AVG_54 3m HORN_91200_1241 VERTICAL RBW:1000.000KHz VBW:1000KHz SWT:Auto Detector : Peak Project : 8N0620-05 Mode : Z2 Power : 3</p>



2.4GHz 2400~2483.5MHz

WIFI 802.11n HT20 (Band Edge @ 3m)

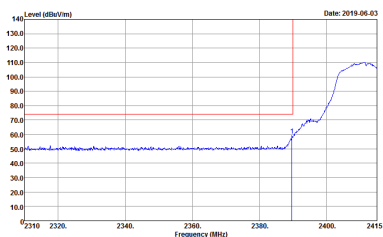
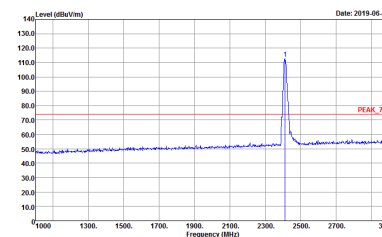
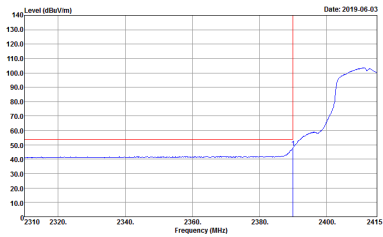
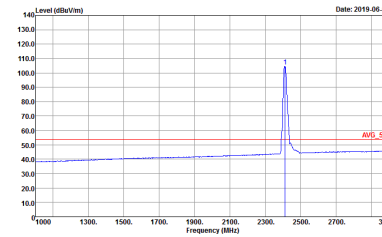
WIFI	2.4GHz 2400~2483.5MHz Band Edge @ 3m	
ANT	802.11n HT20 CH01 2412MHz	
2+4	Horizontal	Fundamental
Peak	 <p>Site : 03CH13-HY Condition : PEAK_BE_74 3m HORN_91200_1241 HORIZONTAL Detector : Peak Project : 8N0620-05 Mode : 23 Power : 19.5</p>	 <p>Site : 03CH13-HY Condition : PEAK_74 3m HORN_91200_1241 HORIZONTAL Detector : Peak Project : 8N0620-05 Mode : 23 Power : 19.5</p>
Avg.	 <p>Site : 03CH13-HY Condition : AVG_BE_54 3m HORN_91200_1241 HORIZONTAL Detector : Peak Project : 8N0620-05 Mode : 23 Power : 19.5</p>	 <p>Site : 03CH13-HY Condition : AVG_54 3m HORN_91200_1241 HORIZONTAL Detector : Peak Project : 8N0620-05 Mode : 23 Power : 19.5</p>

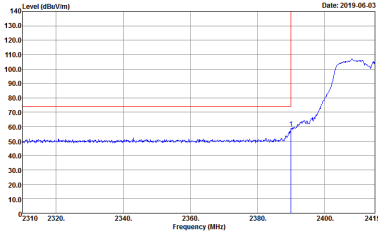
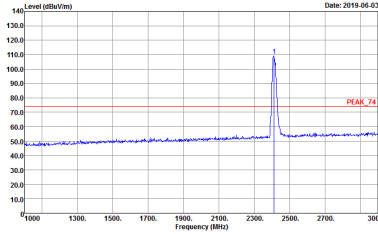
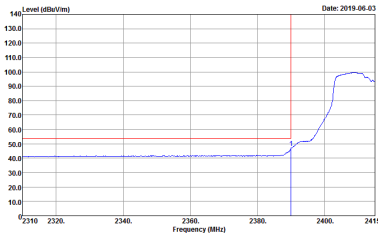
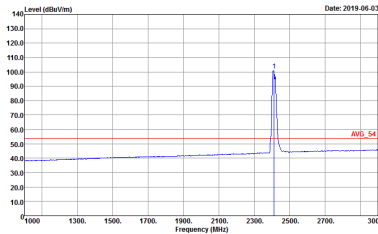

WIFI	2.4GHz 2400~2483.5MHz Band Edge @ 3m	
ANT	802.11n HT20 CH01 2412MHz	
2+4	Vertical	Fundamental
Peak	 <p>Site : 03CH13-HY Condition : PEAK_BE_74 3m HORN_91200_1241 VERTICAL RBW:1000.000KHz VBW:3000.000KHz SWT:Auto Detector : Peak Project : 8N0620-05 Mode : 23 Power : 19.5</p>	 <p>Site : 03CH13-HY Condition : PEAK_74 3m HORN_91200_1241 VERTICAL RBW:1000.000KHz VBW:3000.000KHz SWT:Auto Detector : Peak Project : 8N0620-05 Mode : 23 Power : 19.5</p>
Avg.	 <p>Site : 03CH13-HY Condition : AVG_BE_54 3m HORN_91200_1241 VERTICAL RBW:1000.000KHz VBW:1000KHz SWT:Auto Detector : Peak Project : 8N0620-05 Mode : 23 Power : 19.5</p>	 <p>Site : 03CH13-HY Condition : AVG_54 3m HORN_91200_1241 VERTICAL RBW:1000.000KHz VBW:1000KHz SWT:Auto Detector : Peak Project : 8N0620-05 Mode : 23 Power : 19.5</p>

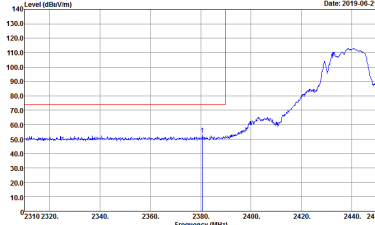
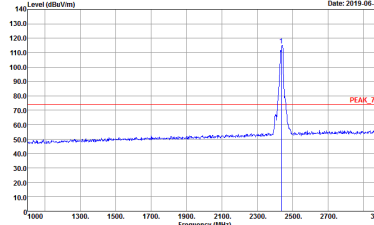
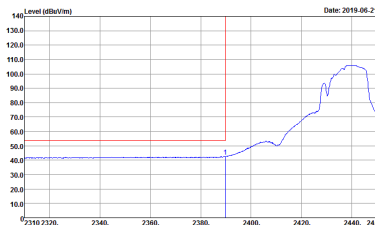
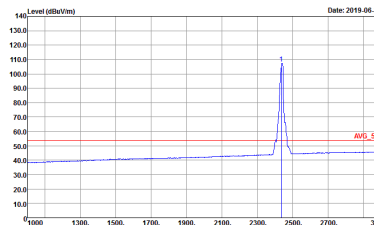

WIFI	2.4GHz 2400~2483.5MHz Band Edge @ 3m	
ANT	802.11n HT20 CH06 2437MHz - L	
2+4	Horizontal	Fundamental
Peak	 <p>Site : 03CH13-HY Condition : PEAK_BE_74 3m HORN_91200_1241 HORIZONTAL RBW:1000.000KHz VBW:3000.000KHz SWT:Auto Detector : Peak Project : 8N0620-05 Mode : 24 Power : 21.5</p>	 <p>Site : 03CH13-HY Condition : PEAK_74 3m HORN_91200_1241 HORIZONTAL RBW:1000.000KHz VBW:3000.000KHz SWT:Auto Detector : Peak Project : 8N0620-05 Mode : 24 Power : 21.5</p>
Avg.	 <p>Site : 03CH13-HY Condition : AVG_BE_54 3m HORN_91200_1241 HORIZONTAL RBW:1000.000KHz VBW:1000KHz SWT:Auto Detector : Peak Project : 8N0620-05 Mode : 24 Power : 21.5</p>	 <p>Site : 03CH13-HY Condition : AVG_54 3m HORN_91200_1241 HORIZONTAL RBW:1000.000KHz VBW:1000KHz SWT:Auto Detector : Peak Project : 8N0620-05 Mode : 24 Power : 21.5</p>

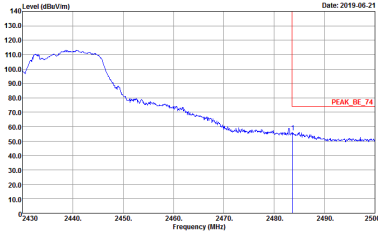
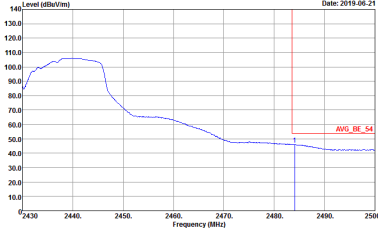

WIFI	2.4GHz 2400~2483.5MHz Band Edge @ 3m	
ANT	802.11n HT20 CH06 2437MHz - R	
2+4	Horizontal	Fundamental
<p>Peak</p>	 <p>Site : 03CH13-HY Condition : PEAK_BE_74 3m HORN_9120D_1241 HORIZONTAL Detector : Peak Project : BN0620-05 Mode : 24 Power : 21.5</p>	<p>Left blank</p>
<p>Avg.</p>	 <p>Site : 03CH13-HY Condition : AVG_BE_54 3m HORN_9120D_1241 HORIZONTAL Detector : Peak Project : BN0620-05 Mode : 24 Power : 21.5</p>	<p>Left blank</p>

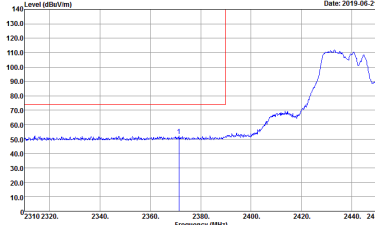
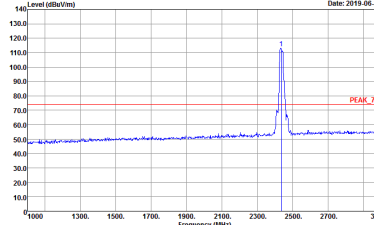
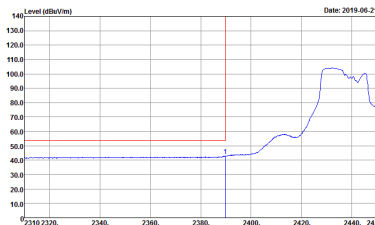
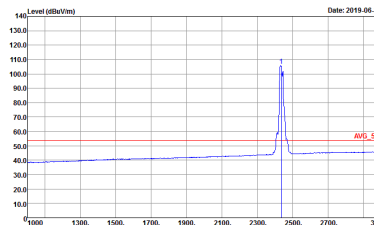

WIFI	2.4GHz 2400~2483.5MHz Band Edge @ 3m	
ANT	802.11n HT20 CH06 2437MHz - L	
2+4	Vertical	Fundamental
Peak	 <p>Site : 03CH13-HY Condition : PEAK_8E_74 3m HORN_91200_1241 VERTICAL RBW:1000.000KHz VBW:3000.000KHz SWT:Auto Detector : Peak Project : 8N0620-05 Mode : 24 Power : 21.5</p>	 <p>Site : 03CH13-HY Condition : PEAK_74 3m HORN_91200_1241 VERTICAL RBW:1000.000KHz VBW:3000.000KHz SWT:Auto Detector : Peak Project : 8N0620-05 Mode : 24 Power : 21.5</p>
Avg.	 <p>Site : 03CH13-HY Condition : AVG_8E_54 3m HORN_91200_1241 VERTICAL RBW:1000.000KHz VBW:1000KHz SWT:Auto Detector : Peak Project : 8N0620-05 Mode : 24 Power : 21.5</p>	 <p>Site : 03CH13-HY Condition : AVG_54 3m HORN_91200_1241 VERTICAL RBW:1000.000KHz VBW:1000KHz SWT:Auto Detector : Peak Project : 8N0620-05 Mode : 24 Power : 21.5</p>

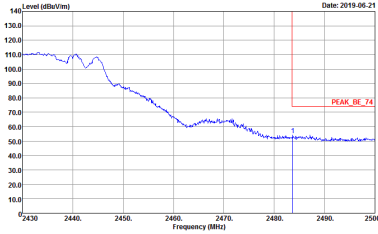
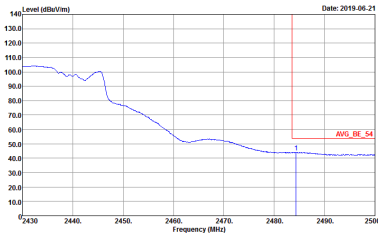

WIFI	2.4GHz 2400~2483.5MHz Band Edge @ 3m	
ANT	802.11n HT20 CH06 2437MHz - R	
2+4	Vertical	Fundamental
<p>Peak</p>	 <p>Site : 03CH13-HY Condition : PEAK_BE_74 3m HORN_9120D_1241 VERTICAL Detector : Peak Project : BN0620-05 Mode : 24 Power : 21.5</p>	<p>Left Blank</p>
<p>Avg.</p>	 <p>Site : 03CH13-HY Condition : AVG_BE_54 3m HORN_9120D_1241 VERTICAL Detector : Peak Project : BN0620-05 Mode : 24 Power : 21.5</p>	<p>Left Blank</p>

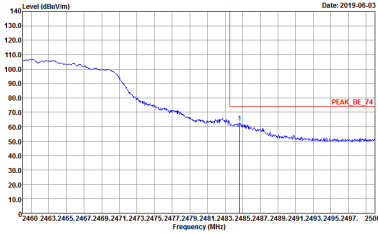
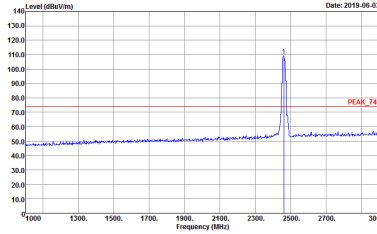
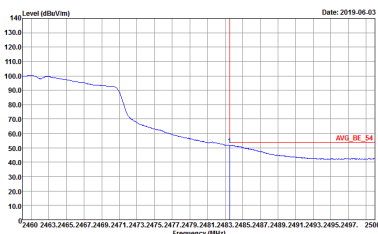
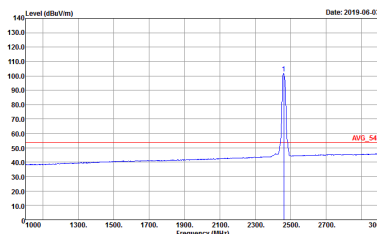

WIFI	2.4GHz 2400~2483.5MHz Band Edge @ 3m	
ANT	802.11n HT20 CH11 2462MHz	
2+4	Horizontal	Fundamental
Peak	 <p>Site : 03CH13-HY Condition : PEAK_BE_74 3m HORN_91200_1241 HORIZONTAL RBW:1000.000KHz VBW:3000.000KHz SWT:Auto Detector : Peak Project : 8N0620-05 Mode : 25 Power : 16</p>	 <p>Site : 03CH13-HY Condition : PEAK_74 3m HORN_91200_1241 HORIZONTAL RBW:1000.000KHz VBW:3000.000KHz SWT:Auto Detector : Peak Project : 8N0620-05 Mode : 25 Power : 16</p>
Avg.	 <p>Site : 03CH13-HY Condition : AVG_BE_54 3m HORN_91200_1241 HORIZONTAL RBW:1000.000KHz VBW:1000KHz SWT:Auto Detector : Peak Project : 8N0620-05 Mode : 25 Power : 16</p>	 <p>Site : 03CH13-HY Condition : AVG_54 3m HORN_91200_1241 HORIZONTAL RBW:1000.000KHz VBW:1000KHz SWT:Auto Detector : Peak Project : 8N0620-05 Mode : 25 Power : 16</p>

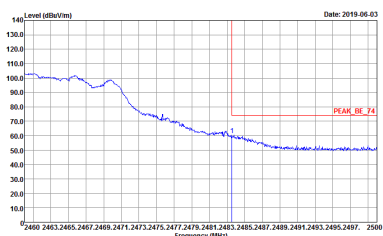
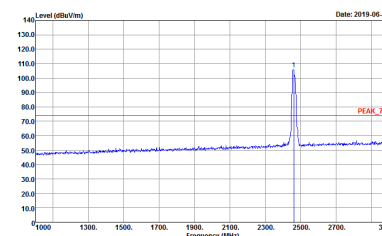
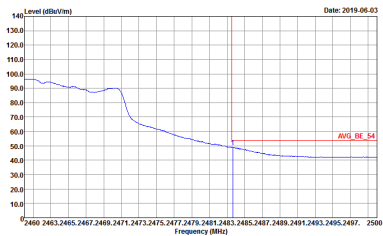
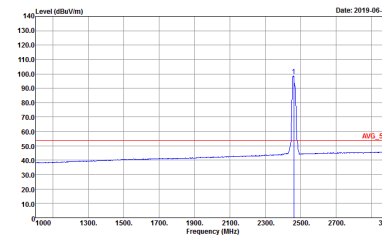

WIFI	2.4GHz 2400~2483.5MHz Fundamental @ 3m	
ANT	802.11n HT20 CH11 2462MHz	
2+4	Vertical	Fundamental
Peak	 <p>Site : 03CH13-HY Condition : PEAK_BE_74 3m HORN_91200_1241 VERTICAL RBW:1000.000KHz VBW:3000.000KHz SWT:Auto Detector : Peak Project : BN0620-05 Mode : 25 Power : 16</p>	 <p>Site : 03CH13-HY Condition : PEAK_74 3m HORN_91200_1241 VERTICAL RBW:1000.000KHz VBW:3000.000KHz SWT:Auto Detector : Peak Project : BN0620-05 Mode : 25 Power : 16</p>
Avg.	 <p>Site : 03CH13-HY Condition : AVG_BE_54 3m HORN_91200_1241 VERTICAL RBW:1000.000KHz VBW:1000KHz SWT:Auto Detector : Peak Project : BN0620-05 Mode : 25 Power : 16</p>	 <p>Site : 03CH13-HY Condition : AVG_54 3m HORN_91200_1241 VERTICAL RBW:1000.000KHz VBW:1000KHz SWT:Auto Detector : Peak Project : BN0620-05 Mode : 25 Power : 16</p>

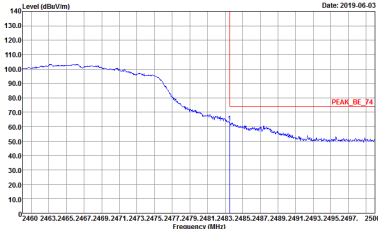
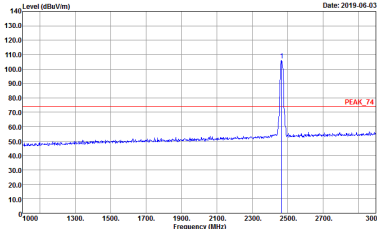
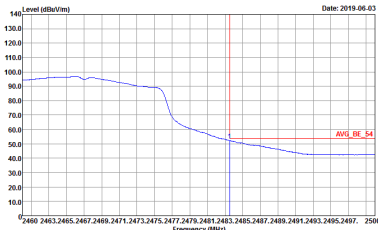
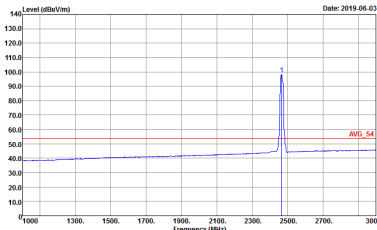

WIFI	2.4GHz 2400~2483.5MHz Band Edge @ 3m	
ANT	802.11n HT20 CH12 2467MHz	
2+4	Horizontal	Fundamental
<p>Peak</p>	 <p>Site : 03CH13-HY Condition : PEAK_BE_74 3m HORN_91200_1241 HORIZONTAL RBW:1000.000KHz VBW:3000.000KHz SWT:Auto Detector : Peak Project : 8N0620-05 Mode : 26 Power : 12.5</p>	 <p>Site : 03CH13-HY Condition : PEAK_74 3m HORN_91200_1241 HORIZONTAL RBW:1000.000KHz VBW:3000.000KHz SWT:Auto Detector : Peak Project : 8N0620-05 Mode : 26 Power : 12.5</p>
<p>Avg.</p>	 <p>Site : 03CH13-HY Condition : AVG_BE_54 3m HORN_91200_1241 HORIZONTAL RBW:1000.000KHz VBW:1000KHz SWT:Auto Detector : Peak Project : 8N0620-05 Mode : 26 Power : 12.5</p>	 <p>Site : 03CH13-HY Condition : AVG_54 3m HORN_91200_1241 HORIZONTAL RBW:1000.000KHz VBW:1000KHz SWT:Auto Detector : Peak Project : 8N0620-05 Mode : 26 Power : 12.5</p>

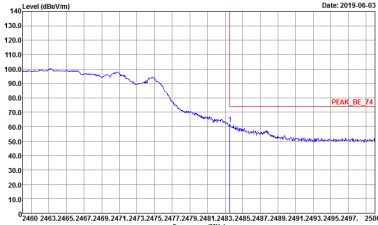
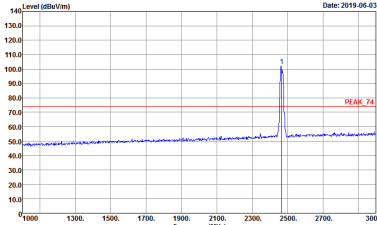
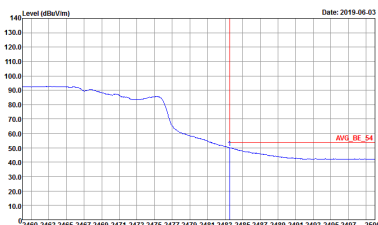
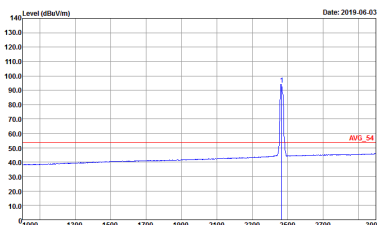

WIFI	2.4GHz 2400~2483.5MHz Band Edge @ 3m	
ANT	802.11n HT20 CH12 2467MHz	
2+4	Vertical	Fundamental
Peak	 <p>Site : 03CH13-HY Condition : PEAK_BE_74 3m HORN_91200_1241 VERTICAL RBW:1000.000KHz VBW:3000.000KHz SWT:Auto Detector : Peak Project : 8N0620-05 Mode : 26 Power : 12.5</p>	 <p>Site : 03CH13-HY Condition : PEAK_74 3m HORN_91200_1241 VERTICAL RBW:1000.000KHz VBW:3000.000KHz SWT:Auto Detector : Peak Project : 8N0620-05 Mode : 26 Power : 12.5</p>
Avg.	 <p>Site : 03CH13-HY Condition : AVG_BE_54 3m HORN_91200_1241 VERTICAL RBW:1000.000KHz VBW:1000KHz SWT:Auto Detector : Peak Project : 8N0620-05 Mode : 26 Power : 12.5</p>	 <p>Site : 03CH13-HY Condition : AVG_54 3m HORN_91200_1241 VERTICAL RBW:1000.000KHz VBW:1000KHz SWT:Auto Detector : Peak Project : 8N0620-05 Mode : 26 Power : 12.5</p>

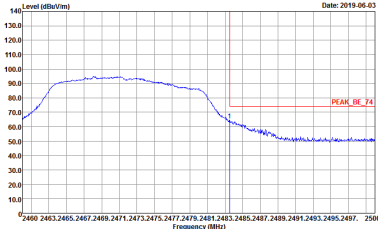
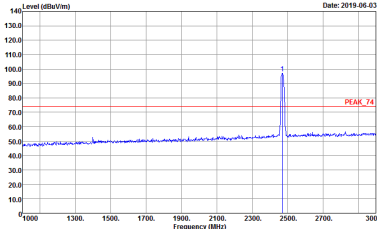
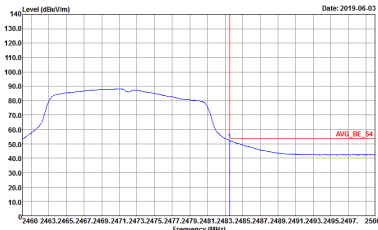
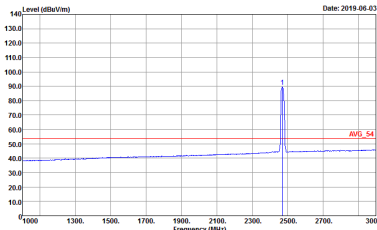

WIFI	2.4GHz 2400~2483.5MHz Band Edge @ 3m	
ANT	802.11n HT20 CH13 2472MHz	
2+4	Horizontal	Fundamental
<p>Peak</p>	 <p>Site : 03CH13-HY Condition : PEAK_BE_74 3m HORN_91200_1241 HORIZONTAL RBW:1000.000KHz VBW:3000.000KHz SWT:Auto Detector : Peak Project : 8N0620-05 Mode : 27 Power : 4</p>	 <p>Site : 03CH13-HY Condition : PEAK_74 3m HORN_91200_1241 HORIZONTAL RBW:1000.000KHz VBW:3000.000KHz SWT:Auto Detector : Peak Project : 8N0620-05 Mode : 27 Power : 4</p>
<p>Avg.</p>	 <p>Site : 03CH13-HY Condition : AVG_BE_54 3m HORN_91200_1241 HORIZONTAL RBW:1000.000KHz VBW:1000KHz SWT:Auto Detector : Peak Project : 8N0620-05 Mode : 27 Power : 4</p>	 <p>Site : 03CH13-HY Condition : AVG_54 3m HORN_91200_1241 HORIZONTAL RBW:1000.000KHz VBW:1000KHz SWT:Auto Detector : Peak Project : 8N0620-05 Mode : 27 Power : 4</p>

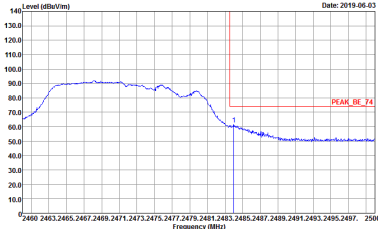
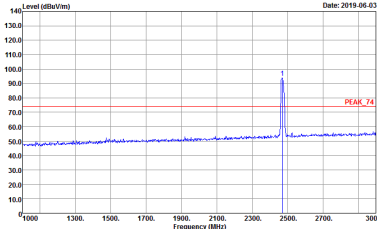
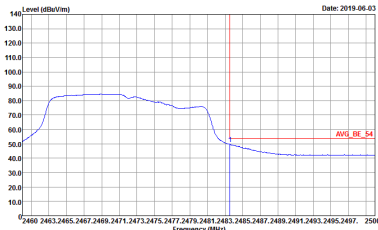
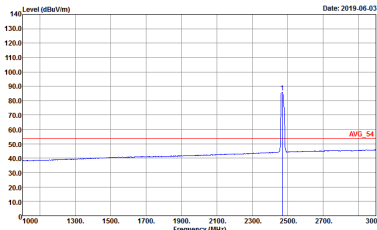

WIFI	2.4GHz 2400~2483.5MHz Band Edge @ 3m	
ANT	802.11n HT20 CH13 2472MHz	
2+4	Vertical	Fundamental
Peak	 <p>Site : 03CH13-HY Condition : PEAK_BE_74 3m HORN_91200_1241 VERTICAL RBW:1000.000KHz VBW:3000.000KHz SWT:Auto Detector : Peak Project : 8N0620-05 Mode : 27 Power : 4</p>	 <p>Site : 03CH13-HY Condition : PEAK_74 3m HORN_91200_1241 VERTICAL RBW:1000.000KHz VBW:3000.000KHz SWT:Auto Detector : Peak Project : 8N0620-05 Mode : 27 Power : 4</p>
Avg.	 <p>Site : 03CH13-HY Condition : AVG_BE_54 3m HORN_91200_1241 VERTICAL RBW:1000.000KHz VBW:1000KHz SWT:Auto Detector : Peak Project : 8N0620-05 Mode : 27 Power : 4</p>	 <p>Site : 03CH13-HY Condition : AVG_54 3m HORN_91200_1241 VERTICAL RBW:1000.000KHz VBW:1000KHz SWT:Auto Detector : Peak Project : 8N0620-05 Mode : 27 Power : 4</p>



2.4GHz 2400~2483.5MHz

WIFI 802.11b (Harmonic @ 3m)

WIFI	2.4GHz 2400~2483.5MHz Harmonic @ 3m	
ANT	802.11b CH01 2412MHz	
2+4	Horizontal	Vertical
Peak Avg.		

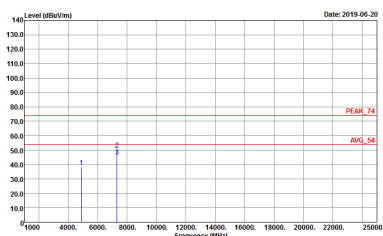
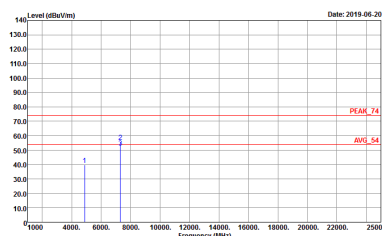

WIFI	2.4GHz 2400~2483.5MHz Harmonic @ 3m	
ANT	802.11b CH06 2437MHz	
2+4	Horizontal	Vertical
<p>Peak</p> <p>Avg.</p>	 <p>Site : 03CH13-HY Condition : PEAK_74 3m HORN_9120D_1241 HORIZONTAL Detector : Peak Project : BN0620-05 Mode : 14 Power : 20</p>	 <p>Site : 03CH13-HY Condition : PEAK_74 3m HORN_9120D_1241 VERTICAL Detector : Peak Project : BN0620-05 Mode : 14 Power : 20</p>

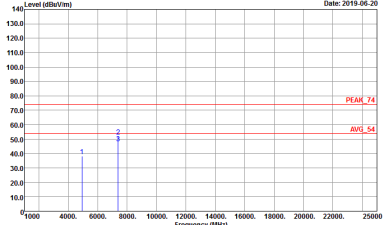
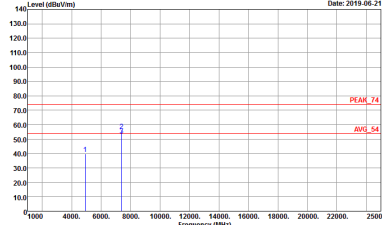

WIFI	2.4GHz 2400~2483.5MHz Harmonic @ 3m	
ANT	802.11b CH11 2462MHz	
2+4	Horizontal	Vertical
<p>Peak</p> <p>Avg.</p>	 <p>Date: 2019-06-20</p> <p>Site : 03CH13-HY Condition : PEAK_74 3m HORN_9120D_1241 HORIZONTAL Detector : Peak Project : BN0620-05 Mode : 15 Power : 20</p>	 <p>Date: 2019-06-21</p> <p>Site : 03CH13-HY Condition : PEAK_74 3m HORN_9120D_1241 VERTICAL Detector : Peak Project : BN0620-05 Mode : 15 Power : 20</p>



WIFI	2.4GHz 2400~2483.5MHz Harmonic @ 3m	
ANT	802.11b CH12 2467MHz	
2+4	Horizontal	Vertical
Peak Avg.	<p>Site : 03CH12-HY Condition : PEAK_74 3m HORN_9120D_1241 HORIZONTAL Detector : Peak Project : BN0620-05 Mode : 16 Power : 17</p>	<p>Site : 03CH12-HY Condition : PEAK_74 3m HORN_9120D_1241 VERTICAL Detector : Peak Project : BN0620-05 Mode : 16 Power : 17</p>



WIFI	2.4GHz 2400~2483.5MHz Harmonic @ 3m	
ANT	802.11b CH13 2472MHz	
2+4	Horizontal	Vertical
Peak Avg.	<p>Site : 03CH13-HY Condition : PEAK_74 3m HORN_9120D_1241 HORIZONTAL Detector : Peak Project : BN0620-05 Mode : 17 Power : 17</p>	<p>Site : 03CH13-HY Condition : PEAK_74 3m HORN_9120D_1241 VERTICAL Detector : Peak Project : BN0620-05 Mode : 17 Power : 17</p>



2.4GHz 2400~2483.5MHz

WIFI 802.11g (Harmonic @ 3m)

WIFI	2.4GHz 2400~2483.5MHz Harmonic @ 3m	
ANT	802.11g CH01 2412MHz	
2+4	Horizontal	Vertical
Peak Avg.	<p>Site : 03CH13-1FY Condition : PEAK_74 3m HORN_9120D_1241 HORIZONTAL Detector : Peak Project : 8N0620-05 Mode : 1B Power : 19.5</p>	<p>Site : 03CH13-1FY Condition : PEAK_74 3m HORN_9120D_1241 VERTICAL Detector : Peak Project : 8N0620-05 Mode : 1B Power : 19.5</p>

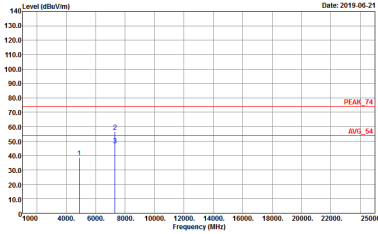
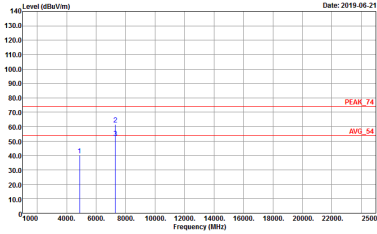

WIFI	2.4GHz 2400~2483.5MHz Harmonic @ 3m	
ANT	802.11g CH06 2437MHz	
2+4	Horizontal	Vertical
<p>Peak</p> <p>Avg.</p>	 <p>Site : 03CH13-HY Condition : PEAK_74 3m HORN_9120D_1241 HORIZONTAL Detector : Peak Project : BN0620-05 Mode : 19 Power : 22</p>	 <p>Site : 03CH13-HY Condition : PEAK_74 3m HORN_9120D_1241 VERTICAL Detector : Peak Project : BN0620-05 Mode : 19 Power : 22</p>

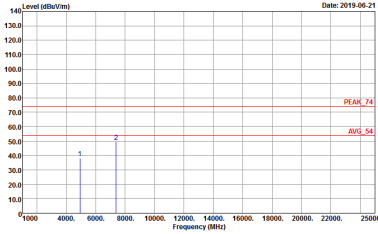
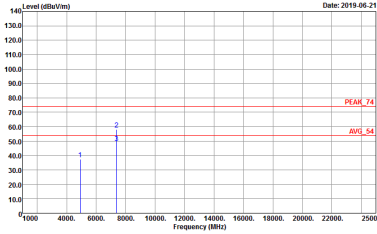

WIFI	2.4GHz 2400~2483.5MHz Harmonic @ 3m	
ANT	802.11g CH11 2462MHz	
2+4	Horizontal	Vertical
Peak Avg.	 <p>Site : 03CH13-HY Condition : PEAK_74 3m HORN_9120D_1241 HORIZONTAL Detector : Peak Project : BN0620-05 Mode : 20 Power : 19</p>	 <p>Site : 03CH13-HY Condition : PEAK_74 3m HORN_9120D_1241 VERTICAL Detector : Peak Project : BN0620-05 Mode : 20 Power : 19</p>



WIFI	2.4GHz 2400~2483.5MHz Harmonic @ 3m	
ANT	802.11g CH12 2467MHz	
2+4	Horizontal	Vertical
Peak Avg.	<p>Site : 03CH12-HY Condition : PEAK_74 3m HORN_9120D_1241 HORIZONTAL Detector : Peak Project : BN0620-05 Mode : 21 Power : 14.5</p>	<p>Site : 03CH12-HY Condition : PEAK_74 3m HORN_9120D_1241 VERTICAL Detector : Peak Project : BN0620-05 Mode : 21 Power : 14.5</p>



WIFI	2.4GHz 2400~2483.5MHz Harmonic @ 3m	
ANT	802.11g CH13 2472MHz	
2+4	Horizontal	Vertical
Peak Avg.	<p>Site : 03CH13-HY Condition : PEAK_74 3m HORN_9120D_1241 HORIZONTAL Detector : Peak Project : BN0620-05 Mode : Z2 Power : 3</p>	<p>Site : 03CH13-HY Condition : PEAK_74 3m HORN_9120D_1241 VERTICAL Detector : Peak Project : BN0620-05 Mode : Z2 Power : 3</p>



2.4GHz 2400~2483.5MHz
WIFI 802.11n HT20 (Harmonic @ 3m)

WIFI	2.4GHz 2400~2483.5MHz Harmonic @ 3m	
ANT	802.11n HT20 CH01 2412MHz	
2+4	Horizontal	Vertical
Peak Avg.	<p>Site : 03CH13-1FY Condition : PEAK_74 3m HORN_9120D_1241 HORIZONTAL Detector : Peak Project : 8N0620-05 Mode : 23 Power : 19.5</p>	<p>Site : 03CH13-1FY Condition : PEAK_74 3m HORN_9120D_1241 VERTICAL Detector : Peak Project : 8N0620-05 Mode : 23 Power : 19.5</p>



WIFI	2.4GHz 2400~2483.5MHz Harmonic @ 3m	
ANT	802.11n HT20 CH06 2437MHz	
2+4	Horizontal	Vertical
Peak Avg.	<p>Site : 03CH13-HY Condition : PEAK_74 3m HORN_9120D_1241 HORIZONTAL Detector : Peak Project : BN0620-05 Mode : 24 Power : 21.5</p>	<p>Site : 03CH13-HY Condition : PEAK_74 3m HORN_9120D_1241 VERTICAL Detector : Peak Project : BN0620-05 Mode : 24 Power : 21.5</p>



WIFI	2.4GHz 2400~2483.5MHz Harmonic @ 3m	
ANT	802.11n HT20 CH11 2462MHz	
2+4	Horizontal	Vertical
Peak Avg.	<p>Site : 03CH12-HY Condition : PEAK_74 3m HORN_9120D_1241 HORIZONTAL Detector : Peak Project : BN0620-05 Mode : 25 Power : 16</p>	<p>Site : 03CH12-HY Condition : PEAK_74 3m HORN_9120D_1241 VERTICAL Detector : Peak Project : BN0620-05 Mode : 25 Power : 16</p>

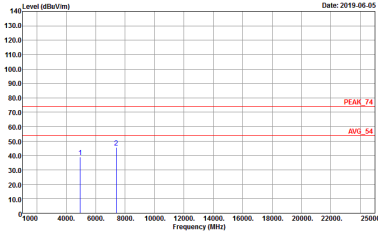
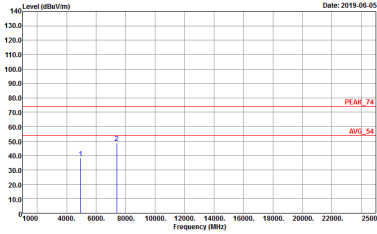

WIFI	2.4GHz 2400~2483.5MHz Harmonic @ 3m	
ANT	802.11n HT20 CH12 2462MHz	
2+4	Horizontal	Vertical
<p>Peak</p> <p>Avg.</p>	 <p>Site : 03CH12-HY Condition : PEAK_74 3m HORN_9120D_1241 HORIZONTAL Detector : Peak Project : BN0620-05 Mode : 26 Power : 12.5</p>	 <p>Site : 03CH12-HY Condition : PEAK_74 3m HORN_9120D_1241 VERTICAL Detector : Peak Project : BN0620-05 Mode : 26 Power : 12.5</p>



WIFI	2.4GHz 2400~2483.5MHz Harmonic @ 3m	
ANT	802.11n HT20 CH13 2472MHz	
2+4	Horizontal	Vertical
Peak Avg.	<p>Site : 03CH13-HY Condition : PEAK_74 3m HORN_9120D_1241 HORIZONTAL Detector : Peak Project : BN0620-05 Mode : 27 Power : 4</p>	<p>Site : 03CH13-HY Condition : PEAK_74 3m HORN_9120D_1241 VERTICAL Detector : Peak Project : BN0620-05 Mode : 27 Power : 4</p>

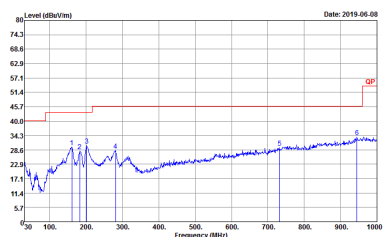
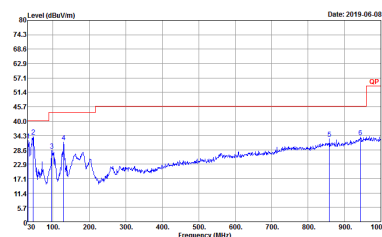

Emission below 1GHz
2.4GHz WIFI 802.11b (LF)

WIFI	2.4GHz 2400~2483.5MHz	
ANT	802.11b LF	
2+4	Horizontal	Vertical
QP / Peak	 <p>Site : 03CH13-HY Condition : QP 3m B1LOG_40103 HORIZONTAL Detector : Peak Project : 8N0620-05 Mode : 28</p>	 <p>Site : 03CH13-HY Condition : QP 3m B1LOG_40103 VERTICAL Detector : Peak Project : 8N0620-05 Mode : 28</p>



<Wireless charging Mode>

2.4GHz 2400~2483.5MHz
WIFI 802.11b (Band Edge @ 3m)

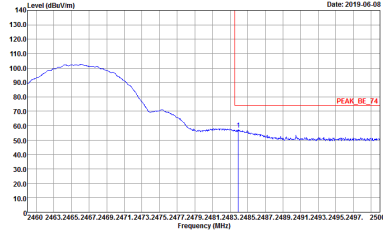
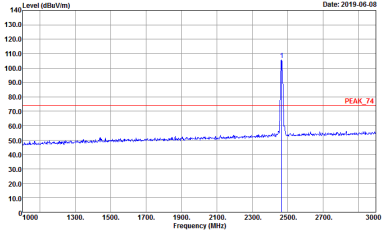
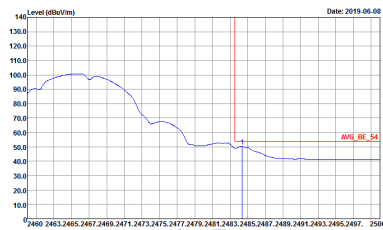
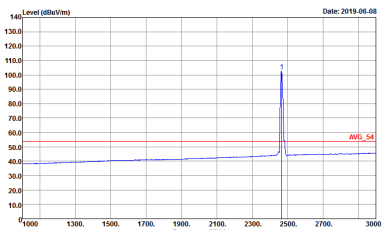
WIFI	2.4GHz 2400~2483.5MHz Band Edge @ 3m	
ANT	802.11b CH12 2467MHz	
2+4	Horizontal	Fundamental
Peak	 <p>Site : 03CH13-HY Condition : PEAK_BE_74 3m HORN_91200_1241 HORIZONTAL Detector : Peak Project : 8N0620-05 Mode : 31 Power : 17</p>	 <p>Site : 03CH13-HY Condition : PEAK_74 3m HORN_91200_1241 HORIZONTAL Detector : Peak Project : 8N0620-05 Mode : 31 Power : 17</p>
Avg.	 <p>Site : 03CH13-HY Condition : AVG_BE_54 3m HORN_91200_1241 HORIZONTAL Detector : Peak Project : 8N0620-05 Mode : 31 Power : 17</p>	 <p>Site : 03CH13-HY Condition : AVG_54 3m HORN_91200_1241 HORIZONTAL Detector : Peak Project : 8N0620-05 Mode : 31 Power : 17</p>

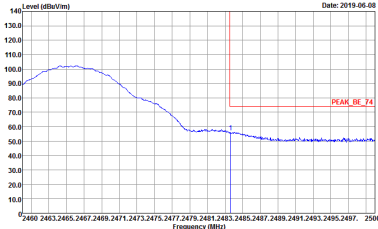
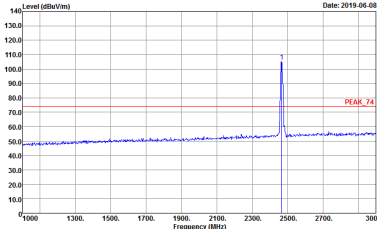
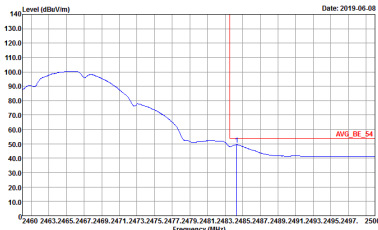
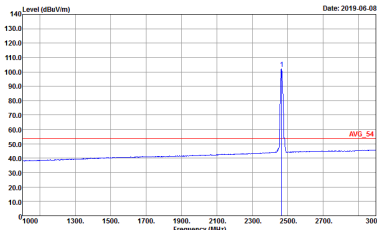

WIFI	2.4GHz 2400~2483.5MHz Band Edge @ 3m	
ANT	802.11b CH12 2467MHz	
2+4	Vertical	Fundamental
Peak	 <p>Site : 03CH13-HY Condition : PEAK_BE_74 3m HORN_91200_1241 VERTICAL RBW:1000.000KHz VBW:3000.000KHz SWT:Auto Detector : Peak Project : 8N0620-05 Mode : 31 Power : 17</p>	 <p>Site : 03CH13-HY Condition : PEAK_74 3m HORN_91200_1241 VERTICAL RBW:1000.000KHz VBW:3000.000KHz SWT:Auto Detector : Peak Project : 8N0620-05 Mode : 31 Power : 17</p>
Avg.	 <p>Site : 03CH13-HY Condition : AVG_BE_54 3m HORN_91200_1241 VERTICAL RBW:1000.000KHz VBW:0.010KHz SWT:Auto Detector : Peak Project : 8N0620-05 Mode : 31 Power : 17</p>	 <p>Site : 03CH13-HY Condition : AVG_54 3m HORN_91200_1241 VERTICAL RBW:1000.000KHz VBW:0.010KHz SWT:Auto Detector : Peak Project : 8N0620-05 Mode : 31 Power : 17</p>



2.4GHz 2400~2483.5MHz

WIFI 802.11b (Harmonic @ 3m)

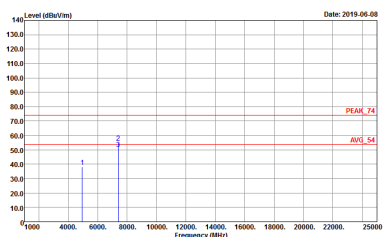
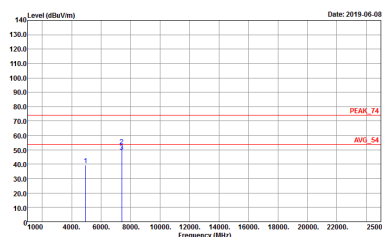
WIFI	2.4GHz 2400~2483.5MHz Harmonic @ 3m	
ANT	802.11b CH12 2467MHz	
2+4	Horizontal	Vertical
<p>Peak Avg.</p>	 <p>Site : 03CH13-HY Condition : PEAK_74 3m HORN_9120D_1241 HORIZONTAL Detector : Peak Project : 8N0625-05 Mode : 31</p>	 <p>Site : 03CH13-HY Condition : PEAK_74 3m HORN_9120D_1241 VERTICAL Detector : Peak Project : 8N0625-05 Mode : 31</p>



Emission below 1GHz
2.4GHz WIFI 802.11b (LF)

WIFI	2.4GHz 2400~2483.5MHz	
ANT	802.11b LF	
2+4	Horizontal	Vertical
QP / Peak	<p>Site : 03CH13-HY Condition : QP 3m BTL0G_40103 HORIZONTAL Detector : Peak Project : 8N0625-05 Mode : 31</p>	<p>Site : 03CH13-HY Condition : QP 3m BTL0G_40103 VERTICAL Detector : Peak Project : 8N0625-05 Mode : 31</p>



Appendix E. Duty Cycle Plots

Antenna	Band	Duty Cycle (%)	T(us)	1/T(kHz)	VBW Setting	Duty Factor(dB)
2+4	802.11b for Ant. 2	99.08	-	-	10Hz	0.04
2+4	802.11b for Ant. 4	99.12	-	-	10Hz	0.04
2+4	802.11g for Ant. 2	97.87	2070.00	0.48	1kHz	0.09
2+4	802.11g for Ant. 4	97.64	2065.00	0.48	1kHz	0.10
2+4	2.4GHz 802.11n HT20 for Ant. 2	97.72	1925.00	0.52	1kHz	0.10
2+4	2.4GHz 802.11n HT20 for Ant. 4	97.97	1930.00	0.52	1kHz	0.09

MIMO <Ant. 2>

802.11b

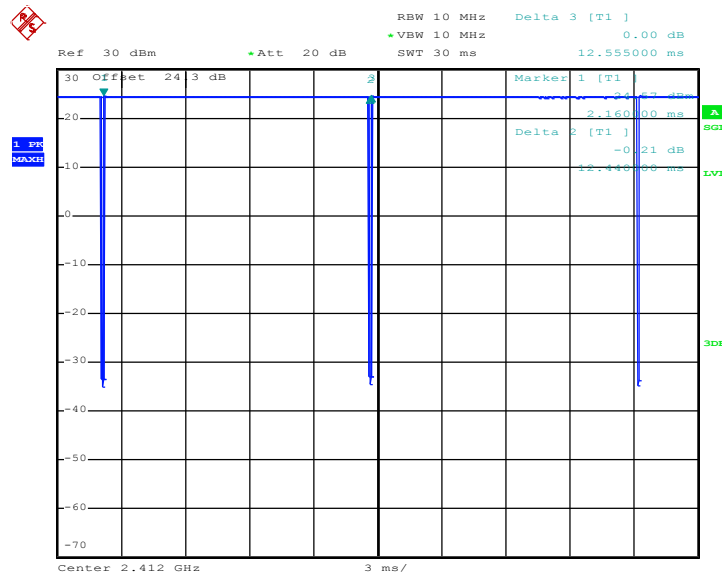

Date: 10.APR.2019 17:54:59



802.11g

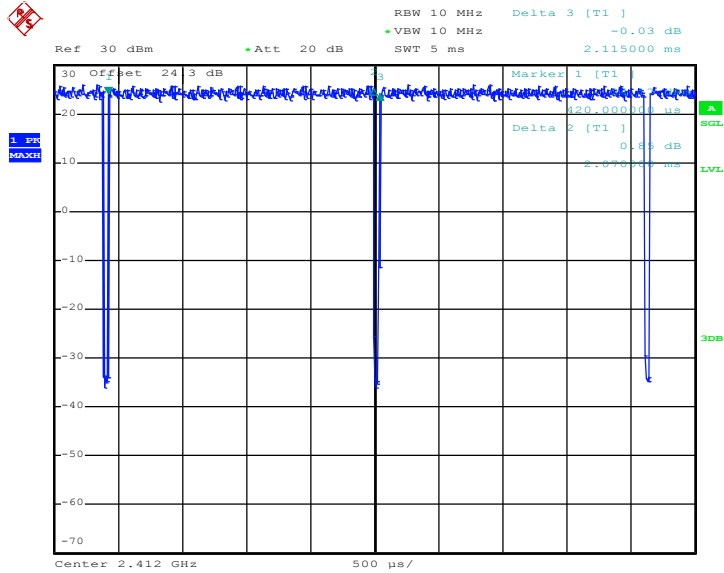

Date: 10.APR.2019 17:58:04

802.11n HT20

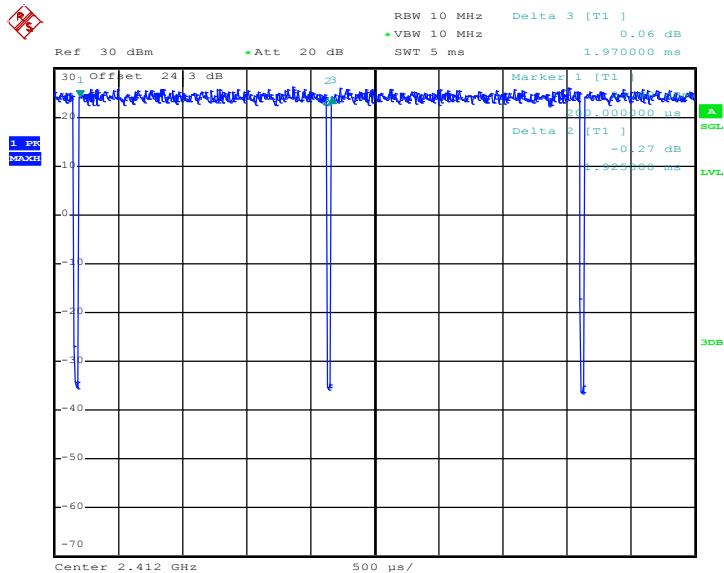

Date: 10.APR.2019 18:00:59



MIMO <Ant. 4>

802.11b

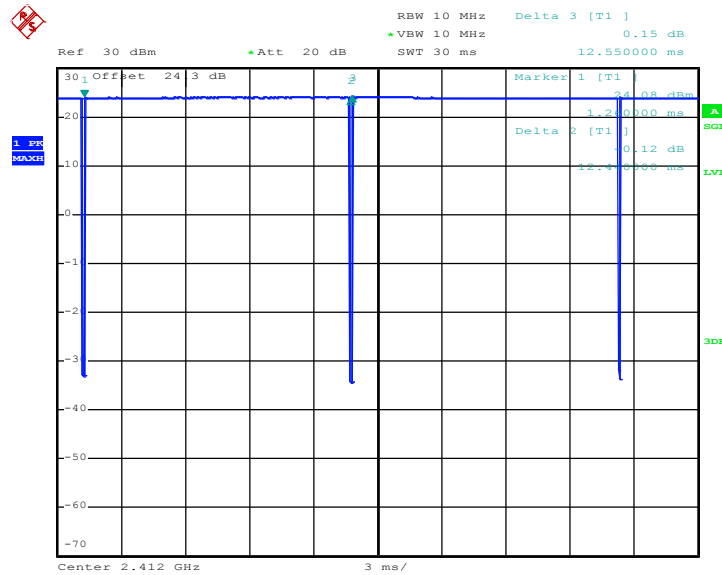

Date: 10.APR.2019 17:55:51

802.11g

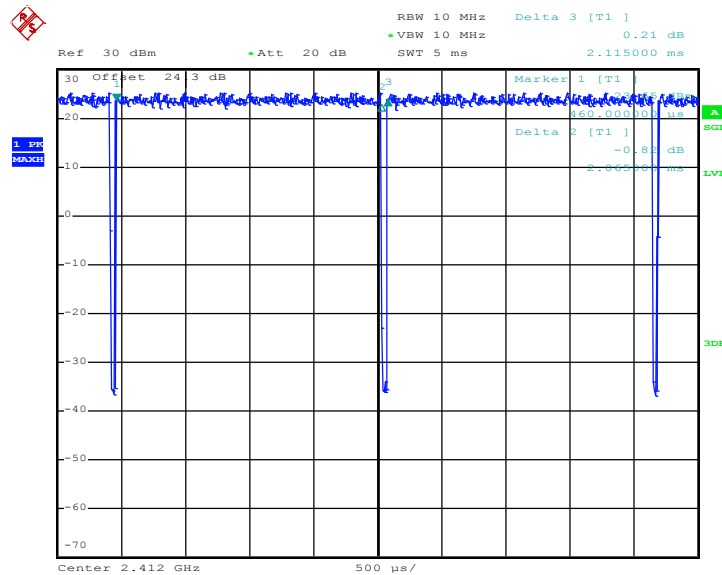

Date: 10.APR.2019 17:58:59



802.11n HT20

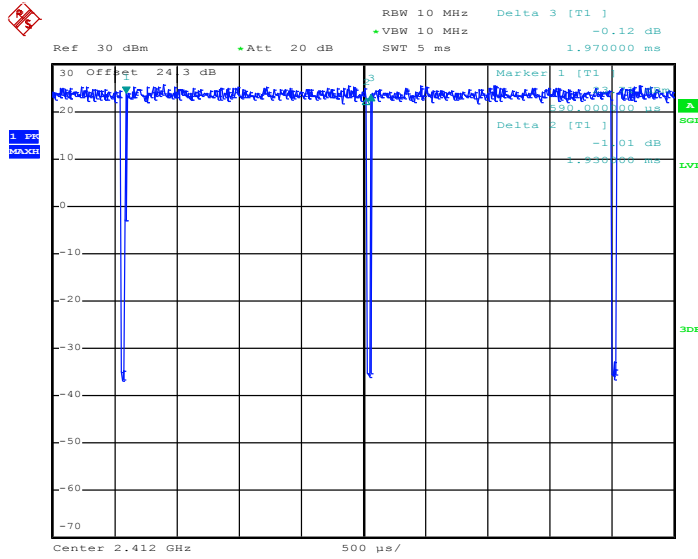

Date: 10.APR.2019 18:00:15

————THE END————