

#01_GSM850_GPRS (4 Tx slots)_Right Cheek_Ch189

Communication System: GSM850 ; Frequency: 836.4 MHz; Duty Cycle: 1:2.08
 Medium: HSL_850_191104 Medium parameters used : $f = 836.4$ MHz; $\sigma = 0.882$ S/m; $\epsilon_r = 41.914$;
 $\rho = 1000$ kg/m³
 Ambient Temperature : 23.6 °C ; Liquid Temperature : 22.6 °C

DASY5 Configuration

- Probe: ES3DV3 - SN3270; ConvF(6.43, 6.43, 6.43) @ 836.4 MHz; Calibrated: 2019/9/25
- Sensor-Surface: 3mm (Mechanical Surface Detection)
- Electronics: DAE3 Sn577; Calibrated: 2019/9/17
- Phantom: Twin-SAM V5.0 (30deg probe tilt); Type: QD 000 P40 CD; Serial: 1885
- Measurement SW: DASY52, Version 52.10 (2); SEMCAD X Version 14.6.12 (7450)

Area Scan (71x121x1): Interpolated grid: $dx=1.500$ mm, $dy=1.500$ mm
 Maximum value of SAR (interpolated) = 0.308 W/kg

Zoom Scan (5x5x7)/Cube 0: Measurement grid: $dx=8$ mm, $dy=8$ mm, $dz=5$ mm
 Reference Value = 18.34 V/m; Power Drift = -0.00 dB
 Peak SAR (extrapolated) = 0.352 W/kg
SAR(1 g) = 0.276 W/kg; SAR(10 g) = 0.208 W/kg
 Maximum value of SAR (measured) = 0.302 W/kg

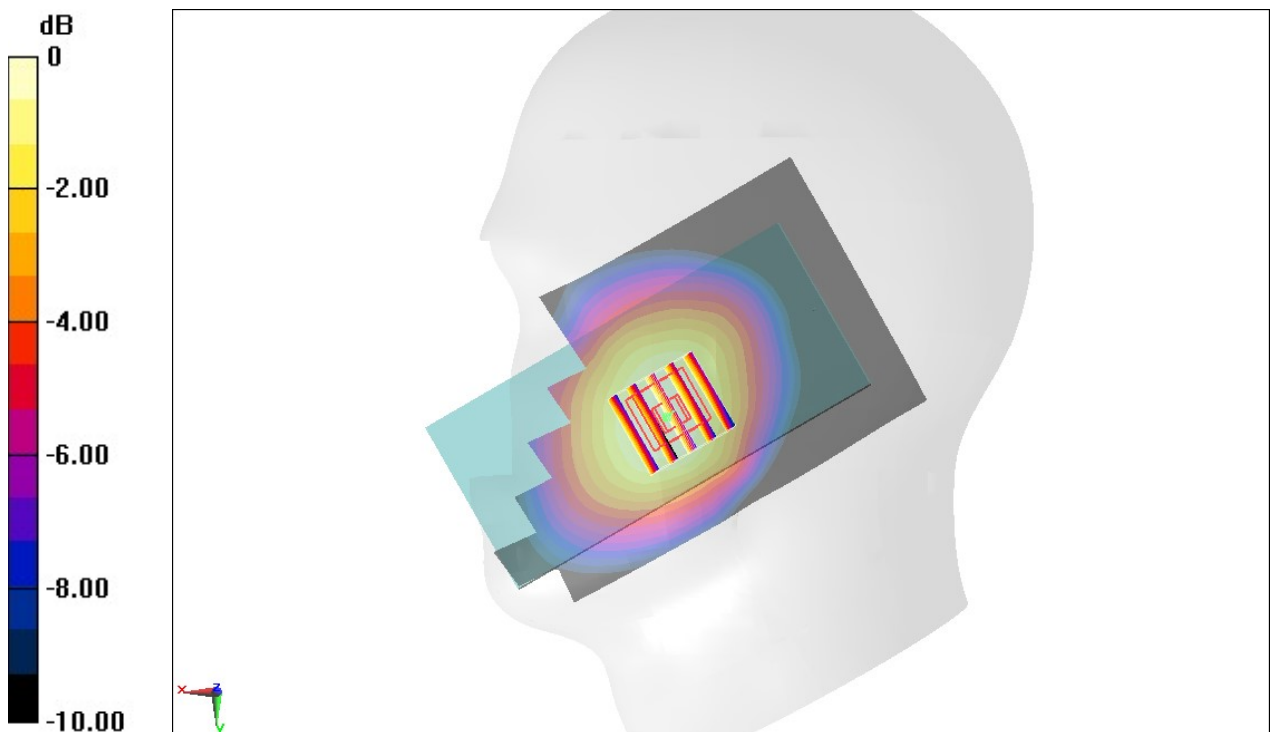

0 dB = 0.302 W/kg = -5.20 dBW/kg

#02_GSM1900_GPRS (4 Tx slots)_Right Cheek_Ch810

Communication System: PCS ; Frequency: 1909.8 MHz;Duty Cycle: 1:2.08
Medium: HSL_1900_191104 Medium parameters used: $f = 1910$ MHz; $\sigma = 1.417$ S/m; $\epsilon_r = 40.537$;
 $\rho = 1000$ kg/m³
Ambient Temperature : 23.6 °C ; Liquid Temperature : 22.6 °C

DASY5 Configuration

- Probe: ES3DV3 - SN3270;ConvF(5.2, 5.2, 5.2) @ 1909.8 MHz;Calibrated: 2019/9/25
- Sensor-Surface: 3mm (Mechanical Surface Detection)
- Electronics: DAE3 Sn577; Calibrated: 2019/9/17
- Phantom: Twin-SAM V5.0 (30deg probe tilt); Type: QD 000 P40 CD; Serial: 1885
- Measurement SW: DASY52, Version 52.10 (2); SEMCAD X Version 14.6.12 (7450)

Area Scan (71x121x1): Interpolated grid: dx=1.500 mm, dy=1.500 mm
Maximum value of SAR (interpolated) = 0.185 W/kg

Zoom Scan (5x5x7)/Cube 0: Measurement grid: dx=8mm, dy=8mm, dz=5mm
Reference Value = 9.511 V/m; Power Drift = 0.19 dB
Peak SAR (extrapolated) = 0.217 W/kg
SAR(1 g) = 0.133 W/kg; SAR(10 g) = 0.078 W/kg
Maximum value of SAR (measured) = 0.160 W/kg

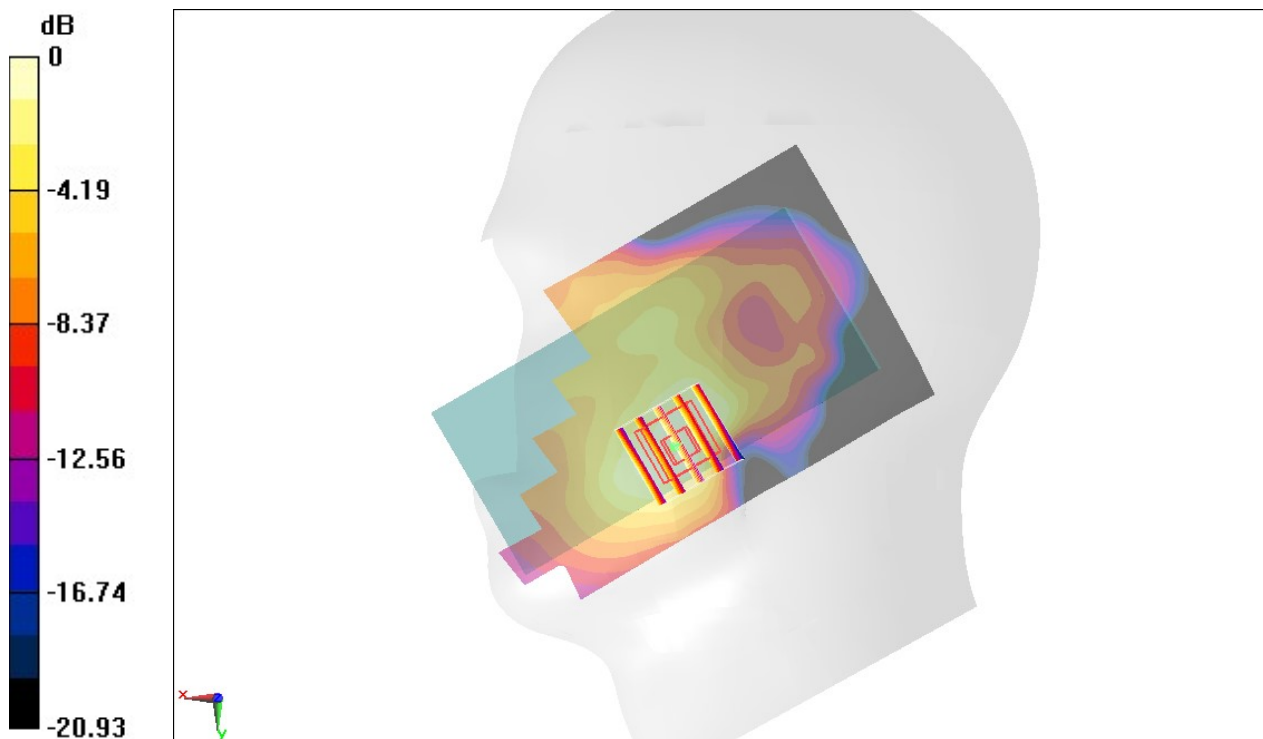

0 dB = 0.160 W/kg = -7.96 dBW/kg

#03_WCDMA IV__RMC 12.2Kbps_Left Cheek_Ch1513

Communication System: WCDMA ; Frequency: 1752.6 MHz;Duty Cycle: 1:1

Medium: HSL_1750_191030 Medium parameters used: $f = 1753$ MHz; $\sigma = 1.355$ S/m; $\epsilon_r = 40.039$; $\rho = 1000$ kg/m³

Ambient Temperature : 23.2 °C ; Liquid Temperature : 22.2 °C

DASY5 Configuration:

- Probe: ES3DV3 - SN3184; ConvF(5.45, 5.45, 5.45) @ 1752.6 MHz; Calibrated: 2019/9/25
- Sensor-Surface: 3mm (Mechanical Surface Detection)
- Electronics: DAE3 Sn495; Calibrated: 2019/5/21
- Phantom: SAM LEFT; Type: QD000P40CD; Serial: TP:1718
- Measurement SW: DASY52, Version 52.10 (2);SEMCAD X Version 14.6.12 (7470)

Area Scan (71x121x1): Interpolated grid: dx=1.500 mm, dy=1.500 mm

Maximum value of SAR (interpolated) = 0.245 W/kg

Zoom Scan (5x5x7)/Cube 0: Measurement grid: dx=8mm, dy=8mm, dz=5mm

Reference Value = 12.12 V/m; Power Drift = 0.03 dB

Peak SAR (extrapolated) = 0.329 W/kg

SAR(1 g) = 0.214 W/kg; SAR(10 g) = 0.136 W/kg

Maximum value of SAR (measured) = 0.247 W/kg

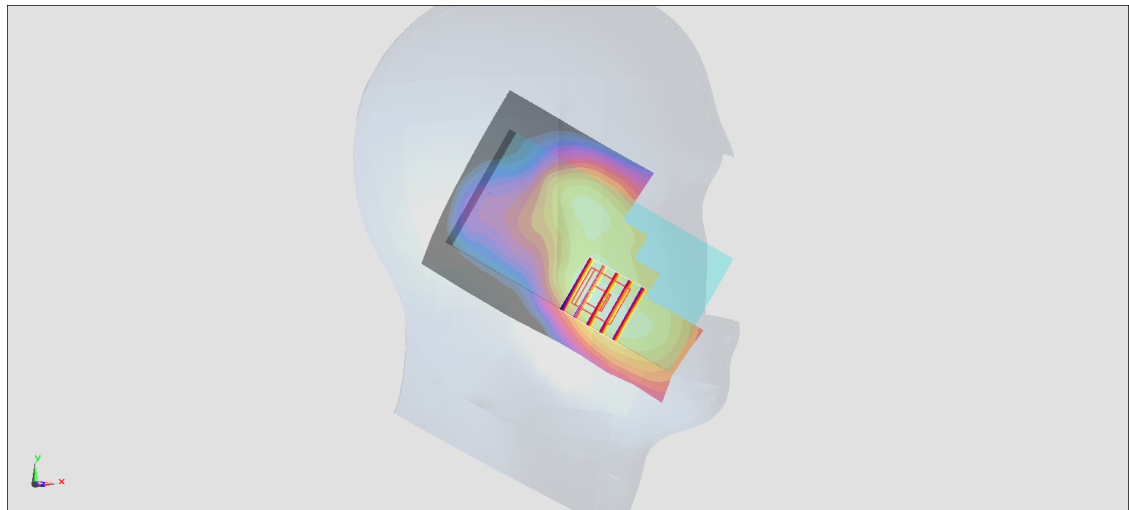
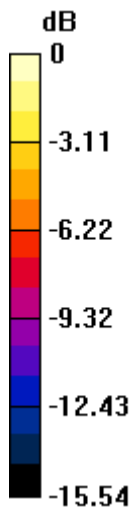

0 dB = 0.247 W/kg = -6.07 dBW/kg

#04_WCDMA V_RMC 12.2Kbps_Right Cheek_Ch4182

Communication System: WCDMA; Frequency: 836.4 MHz; Duty Cycle: 1:1
Medium: HSL_850_191104 Medium parameters used : $f = 836.4$ MHz; $\sigma = 0.882$ S/m; $\epsilon_r = 41.914$;
 $\rho = 1000$ kg/m³
Ambient Temperature : 23.6 °C ; Liquid Temperature : 22.6 °C

DASY5 Configuration

- Probe: ES3DV3 - SN3270; ConvF(6.43, 6.43, 6.43) @ 836.4 MHz; Calibrated: 2019/9/25
- Sensor-Surface: 3mm (Mechanical Surface Detection)
- Electronics: DAE3 Sn577; Calibrated: 2019/9/17
- Phantom: Twin-SAM V5.0 (30deg probe tilt); Type: QD 000 P40 CD; Serial: 1885
- Measurement SW: DASY52, Version 52.10 (2); SEMCAD X Version 14.6.12 (7450)

Area Scan (71x121x1): Interpolated grid: dx=1.500 mm, dy=1.500 mm
Maximum value of SAR (interpolated) = 0.251 W/kg

Zoom Scan (5x5x7)/Cube 0: Measurement grid: dx=8mm, dy=8mm, dz=5mm
Reference Value = 17.10 V/m; Power Drift = 0.04 dB
Peak SAR (extrapolated) = 0.295 W/kg
SAR(1 g) = 0.232 W/kg; SAR(10 g) = 0.176 W/kg
Maximum value of SAR (measured) = 0.254 W/kg

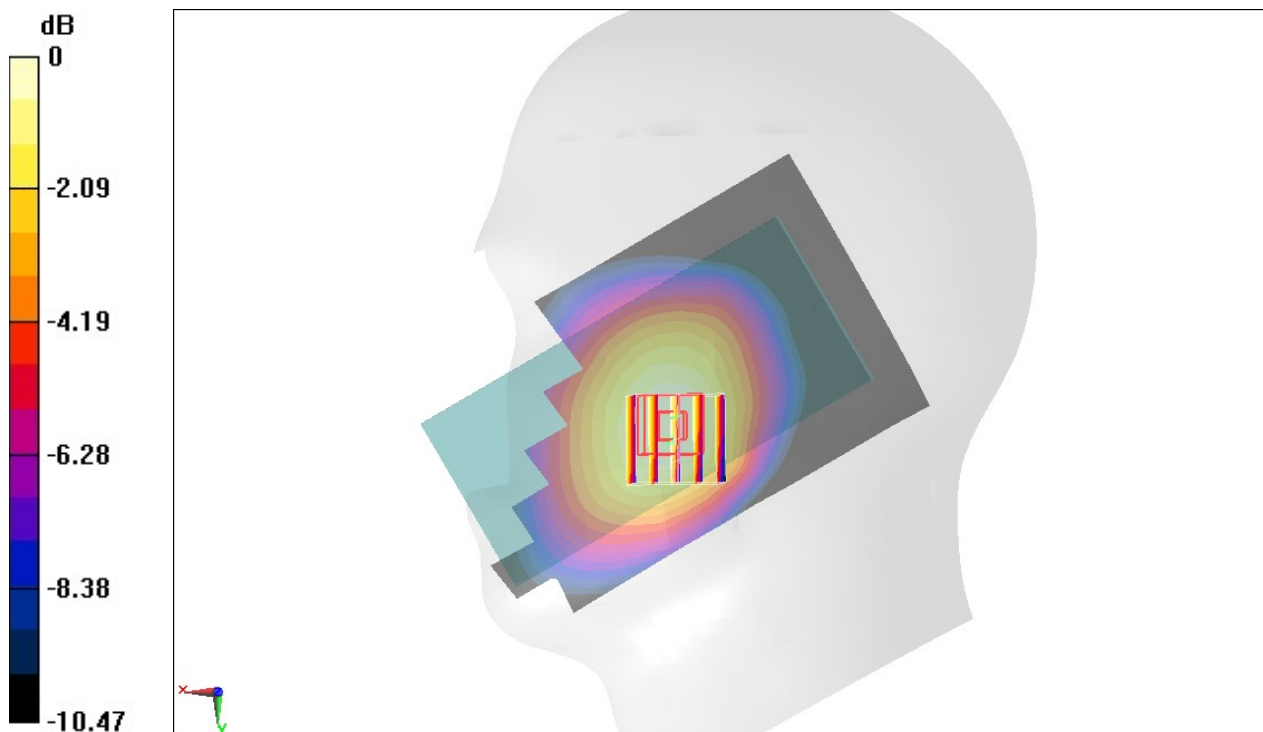

0 dB = 0.254 W/kg = -5.95 dBW/kg

#05_LTE Band 7_20M_QPSK_1_0_Right Cheek_Ch20850

Communication System: LTE; Frequency: 2510 MHz; Duty Cycle: 1:1

Medium: HSL_2600_191105 Medium parameters used: $f = 2510$ MHz; $\sigma = 1.863$ S/m; $\epsilon_r = 39.202$; $\rho = 1000$ kg/m³

Ambient Temperature : 23.4 °C ; Liquid Temperature : 22.4 °C

DASY5 Configuration:

- Probe: EX3DV4 - SN3931; ConvF(7.43, 7.43, 7.43) @ 2510 MHz; Calibrated: 2019/9/26
- Sensor-Surface: 1.4mm (Mechanical Surface Detection)
- Electronics: DAE4 Sn778; Calibrated: 2019/5/21
- Phantom: SAM_Left; Type: QD000P40CD; Serial: TP:1801
- Measurement SW: DASY52, Version 52.10 (2); SEMCAD X Version 14.6.12 (7450)

Area Scan (91x91x1): Interpolated grid: dx=1.200 mm, dy=1.200 mm

Maximum value of SAR (interpolated) = 1.40 W/kg

Zoom Scan (7x7x7)/Cube 0: Measurement grid: dx=5mm, dy=5mm, dz=5mm

Reference Value = 21.29 V/m; Power Drift = -0.04 dB

Peak SAR (extrapolated) = 1.35 W/kg

SAR(1 g) = 0.736 W/kg; SAR(10 g) = 0.388 W/kg

Maximum value of SAR (measured) = 1.14 W/kg

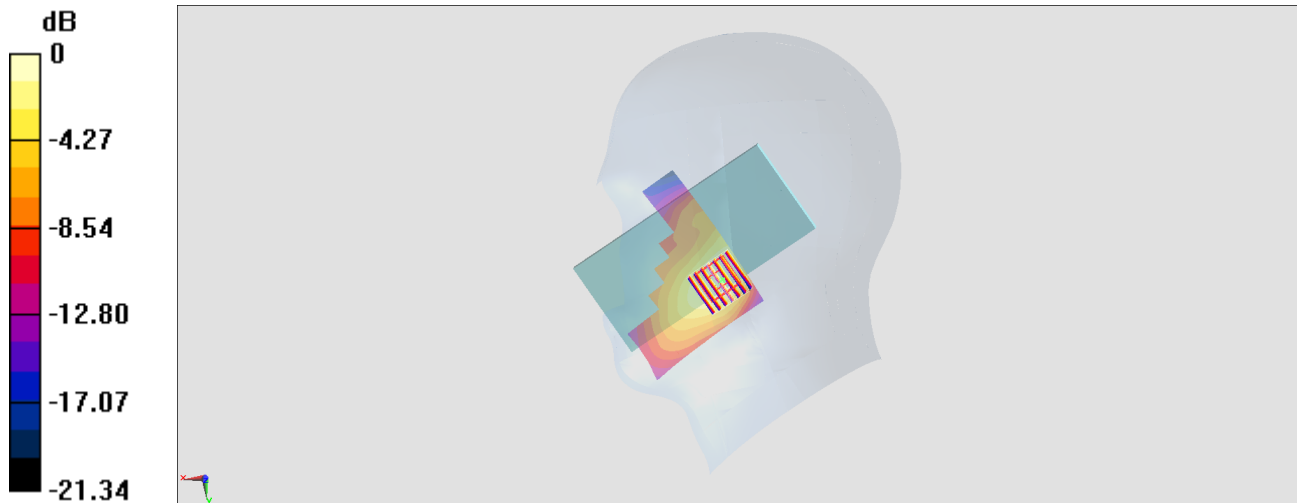

0 dB = 1.14 W/kg = 0.57 dBW/kg

#06_LTE Band 12_10M_QPSK_1_0_Right Cheek_Ch23095

Communication System: LTE; Frequency: 707.5 MHz; Duty Cycle: 1:1

Medium: HSL_750_191107 Medium parameters used : $f = 707.5$ MHz; $\sigma = 0.865$ S/m; $\epsilon_r = 42.738$; $\rho = 1000$ kg/m³

Ambient Temperature : 23.6 °C; Liquid Temperature : 22.6 °C

DASY5 Configuration:

- Probe: EX3DV4 - SN3642; ConvF(9.16, 9.16, 9.16) @ 707.5 MHz; Calibrated: 2019/4/29
- Sensor-Surface: 1.4mm (Mechanical Surface Detection)
- Electronics: DAE4 Sn1399; Calibrated: 2018/11/16
- Phantom: SAM_Left; Type: QD000P40CD; Serial: TP:1801
- Measurement SW: DASY52, Version 52.10 (2); SEMCAD X Version 14.6.12 (7470)

Area Scan (71x121x1): Interpolated grid: dx=1.500 mm, dy=1.500 mm

Maximum value of SAR (interpolated) = 0.213 W/kg

Zoom Scan (5x5x7)/Cube 0: Measurement grid: dx=8mm, dy=8mm, dz=5mm

Reference Value = 17.50 V/m; Power Drift = -0.01 dB

Peak SAR (extrapolated) = 0.266 W/kg

SAR(1 g) = 0.207 W/kg; SAR(10 g) = 0.175 W/kg

Maximum value of SAR (measured) = 0.253 W/kg

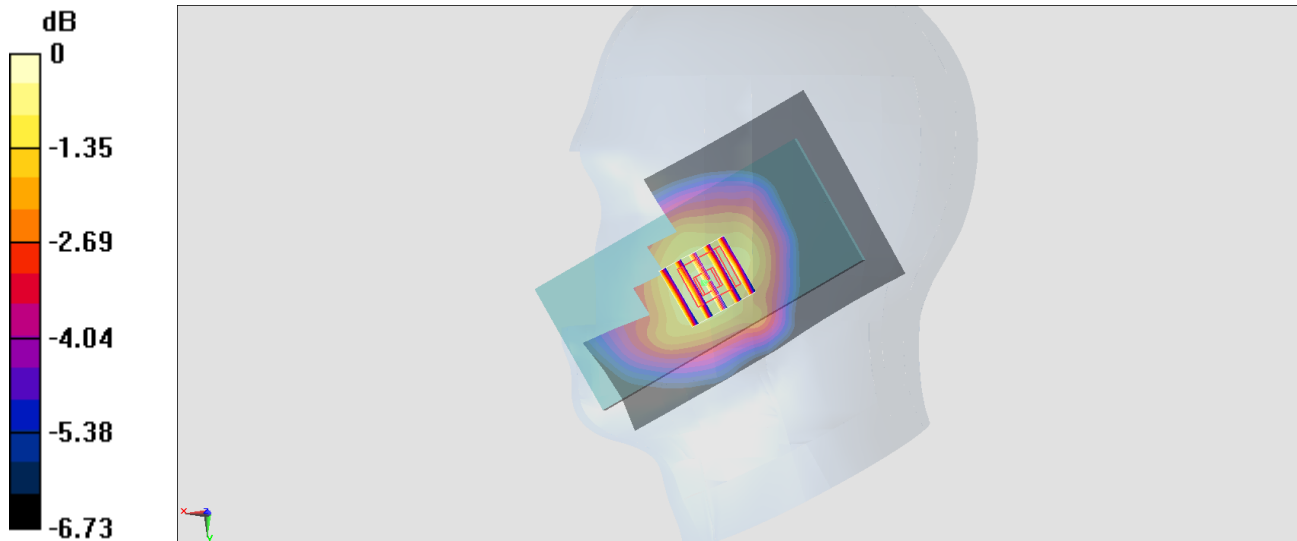

0 dB = 0.253 W/kg = -5.97 dBW/kg

#07_LTE Band 13_10M_QPSK_1_0_Right Cheek_Ch23230

Communication System: LTE ; Frequency: 782 MHz;Duty Cycle: 1:1

Medium: HSL_750_191107 Medium parameters used: $f = 782$ MHz; $\sigma = 0.915$ S/m; $\epsilon_r = 41.68$; $\rho = 1000$ kg/m³

Ambient Temperature : 23.6 °C ; Liquid Temperature : 22.6 °C

DASY5 Configuration:

- Probe: EX3DV4 - SN3642; ConvF(9.16, 9.16, 9.16) @ 782 MHz; Calibrated: 2019/4/29
- Sensor-Surface: 1.4mm (Mechanical Surface Detection)
- Electronics: DAE4 Sn1399; Calibrated: 2018/11/16
- Phantom: SAM_Left; Type: QD000P40CD; Serial: TP:1801
- Measurement SW: DASY52, Version 52.10 (2);SEMCAD X Version 14.6.12 (7470)

Area Scan (71x121x1): Interpolated grid: dx=1.500 mm, dy=1.500 mm

Maximum value of SAR (interpolated) = 0.238 W/kg

Zoom Scan (5x5x7)/Cube 0: Measurement grid: dx=8mm, dy=8mm, dz=5mm

Reference Value = 18.08 V/m; Power Drift = -0.13 dB

Peak SAR (extrapolated) = 0.280 W/kg

SAR(1 g) = 0.227 W/kg; SAR(10 g) = 0.179 W/kg

Maximum value of SAR (measured) = 0.263 W/kg

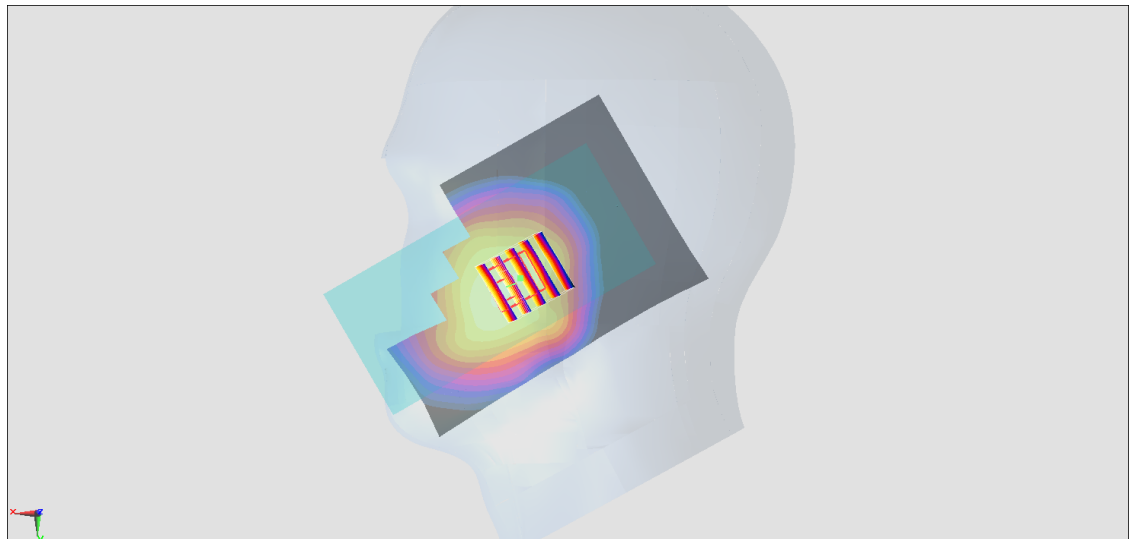
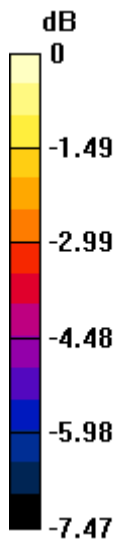

0 dB = 0.263 W/kg = -5.80 dBW/kg

#08_LTE Band 14_10M_QPSK_1_0_Right Cheek_Ch23330

Communication System: LTE ; Frequency: 793 MHz;Duty Cycle: 1:1

Medium: HSL_750_191107 Medium parameters used: $f = 793$ MHz; $\sigma = 0.932$ S/m; $\epsilon_r = 41.517$; $\rho = 1000$ kg/m³

Ambient Temperature : 23.6 °C ; Liquid Temperature : 22.6 °C

DASY5 Configuration:

- Probe: EX3DV4 - SN3642; ConvF(9.16, 9.16, 9.16) @ 793 MHz; Calibrated: 2019/4/29
- Sensor-Surface: 1.4mm (Mechanical Surface Detection)
- Electronics: DAE4 Sn1399; Calibrated: 2018/11/16
- Phantom: SAM_Left; Type: QD000P40CD; Serial: TP:1801
- Measurement SW: DASY52, Version 52.10 (2);SEMCAD X Version 14.6.12 (7470)

Area Scan (71x121x1): Interpolated grid: dx=1.500 mm, dy=1.500 mm

Maximum value of SAR (interpolated) = 0.255 W/kg

Zoom Scan (5x5x7)/Cube 0: Measurement grid: dx=8mm, dy=8mm, dz=5mm

Reference Value = 18.22 V/m; Power Drift = -0.00 dB

Peak SAR (extrapolated) = 0.304 W/kg

SAR(1 g) = 0.236 W/kg; SAR(10 g) = 0.186 W/kg

Maximum value of SAR (measured) = 0.282 W/kg

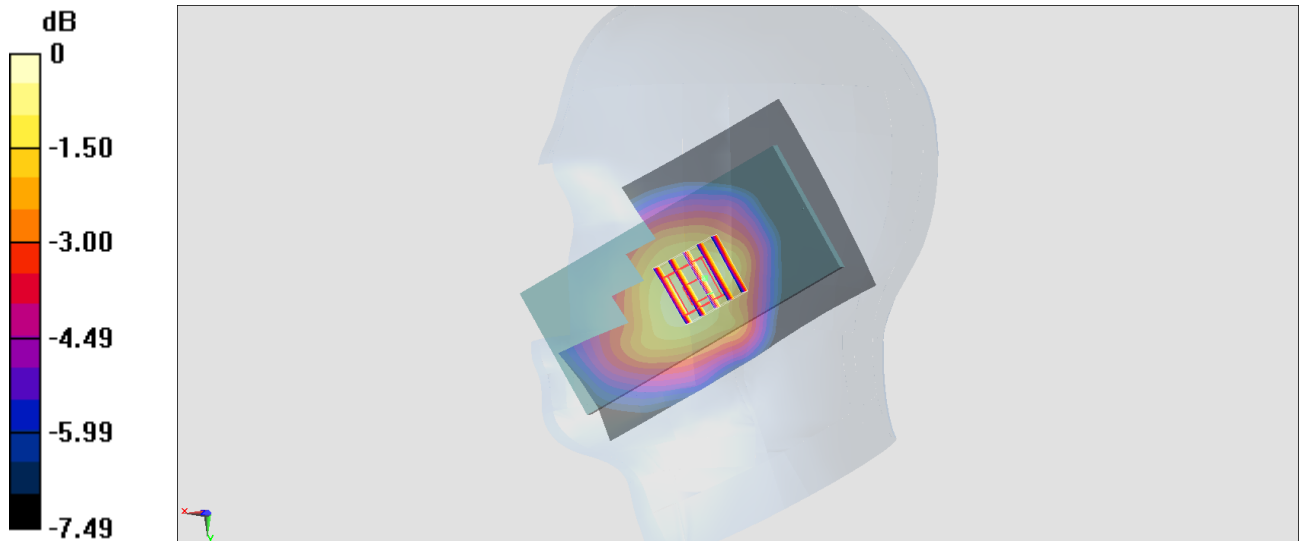

0 dB = 0.282 W/kg = -5.50 dBW/kg

#09_LTE Band 30_10M_QPSK_1_0_Right Cheek_Ch27710

Communication System: LTE ; Frequency: 2310 MHz;Duty Cycle: 1:1

Medium: HSL_2300_191031 Medium parameters used: $f = 2310$ MHz; $\sigma = 1.587$ S/m; $\epsilon_r = 39.4$; $\rho = 1000$ kg/m³

Ambient Temperature : 23.5 °C ; Liquid Temperature : 22.5 °C

DASY5 Configuration:

- Probe: ES3DV3 - SN3184; ConvF(4.96, 4.96, 4.96) @ 2310 MHz; Calibrated: 2019/9/25
- Sensor-Surface: 3mm (Mechanical Surface Detection)
- Electronics: DAE3 Sn495; Calibrated: 2019/5/21
- Phantom: SAM_Front; Type: QD000P40CD; Serial: 1719
- Measurement SW: DASY52, Version 52.10 (2);SEMCAD X Version 14.6.12 (7470)

Area Scan (91x151x1): Interpolated grid: dx=1.200 mm, dy=1.200 mm

Maximum value of SAR (interpolated) = 0.306 W/kg

Zoom Scan (7x7x7)/Cube 0: Measurement grid: dx=5mm, dy=5mm, dz=5mm

Reference Value = 12.88 V/m; Power Drift = 0.07 dB

Peak SAR (extrapolated) = 0.429 W/kg

SAR(1 g) = 0.254 W/kg; SAR(10 g) = 0.143 W/kg

Maximum value of SAR (measured) = 0.312 W/kg

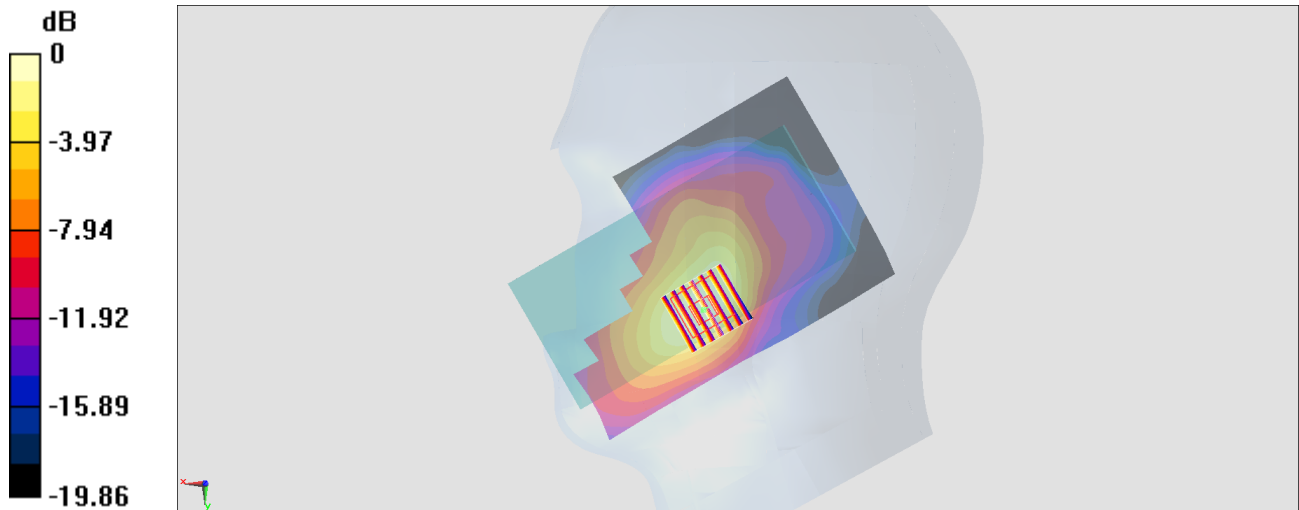

0 dB = 0.312 W/kg = -5.06 dBW/kg

#10_LTE Band 66_20M_QPSK_1_0_Left Cheek_Ch132322

Communication System: LTE; Frequency: 1745 MHz; Duty Cycle: 1:1

Medium: HSL_1750_191029 Medium parameters used : $f = 1745$ MHz; $\sigma = 1.36$ S/m; $\epsilon_r = 40.185$; $\rho = 1000$ kg/m³

Ambient Temperature : 23.6 °C ; Liquid Temperature : 22.6 °C

DASY5 Configuration:

- Probe: ES3DV3 - SN3184; ConvF(5.45, 5.45, 5.45) @ 1745 MHz; Calibrated: 2019/9/25
- Sensor-Surface: 3mm (Mechanical Surface Detection)
- Electronics: DAE3 Sn495; Calibrated: 2019/5/21
- Phantom: SAM LEFT; Type: QD000P40CD; Serial: TP:1718
- Measurement SW: DASY52, Version 52.10 (2); SEMCAD X Version 14.6.12 (7470)

Area Scan (71x121x1): Interpolated grid: dx=1.500 mm, dy=1.500 mm

Maximum value of SAR (interpolated) = 0.260 W/kg

Zoom Scan (5x5x7)/Cube 0: Measurement grid: dx=8mm, dy=8mm, dz=5mm

Reference Value = 12.89 V/m; Power Drift = 0.01 dB

Peak SAR (extrapolated) = 0.324 W/kg

SAR(1 g) = 0.215 W/kg; SAR(10 g) = 0.135 W/kg

Maximum value of SAR (measured) = 0.252 W/kg

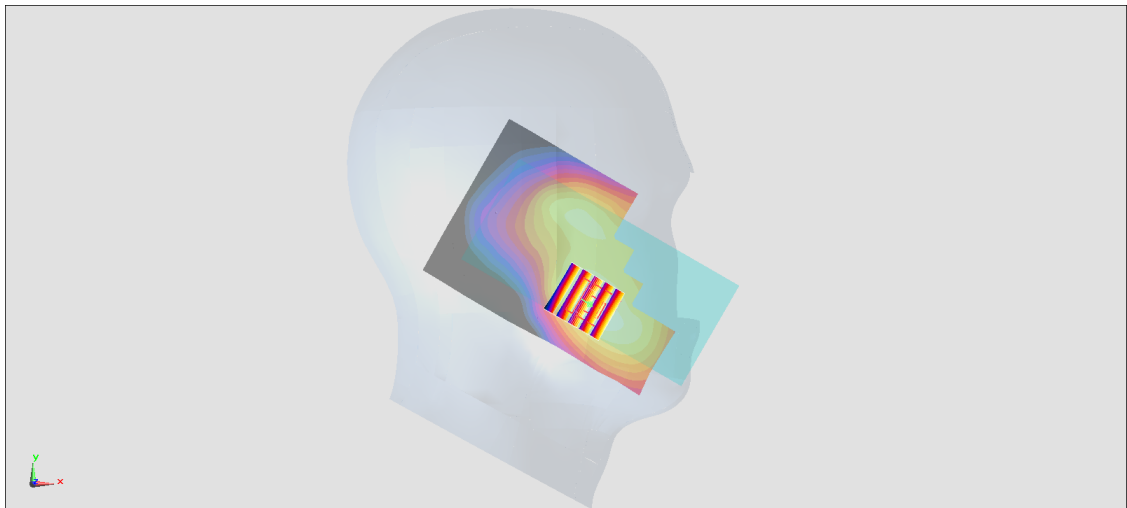
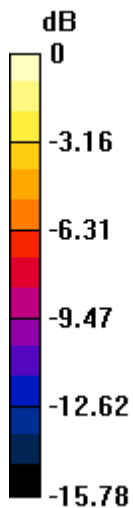

#11_LTE Band 38_20M_QPSK_1_0_Right Cheek_Ch38000

Communication System: LTE ; Frequency: 2595 MHz;Duty Cycle: 1:1.59

Medium: HSL_2600_191106 Medium parameters used : $f = 2595$ MHz; $\sigma = 1.917$ S/m; $\epsilon_r = 37.924$; $\rho = 1000$ kg/m³

Ambient Temperature : 23.4 °C ; Liquid Temperature : 22.4 °C

DASY5 Configuration:

- Probe: EX3DV4 - SN3931; ConvF(7.43, 7.43, 7.43) @ 2595 MHz; Calibrated: 2019/9/26
- Sensor-Surface: 1.4mm (Mechanical Surface Detection)
- Electronics: DAE4 Sn778; Calibrated: 2019/5/21
- Phantom: SAM_Left; Type: QD000P40CD; Serial: TP:1801
- Measurement SW: DASY52, Version 52.10 (2);SEMCAD X Version 14.6.12 (7450)

Area Scan (91x151x1): Interpolated grid: dx=1.200 mm, dy=1.200 mm

Maximum value of SAR (interpolated) = 0.931 W/kg

Zoom Scan (7x7x7)/Cube 0: Measurement grid: dx=5mm, dy=5mm, dz=5mm

Reference Value = 17.57 V/m; Power Drift = 0.10 dB

Peak SAR (extrapolated) = 1.09 W/kg

SAR(1 g) = 0.586 W/kg; SAR(10 g) = 0.301 W/kg

Maximum value of SAR (measured) = 0.902 W/kg

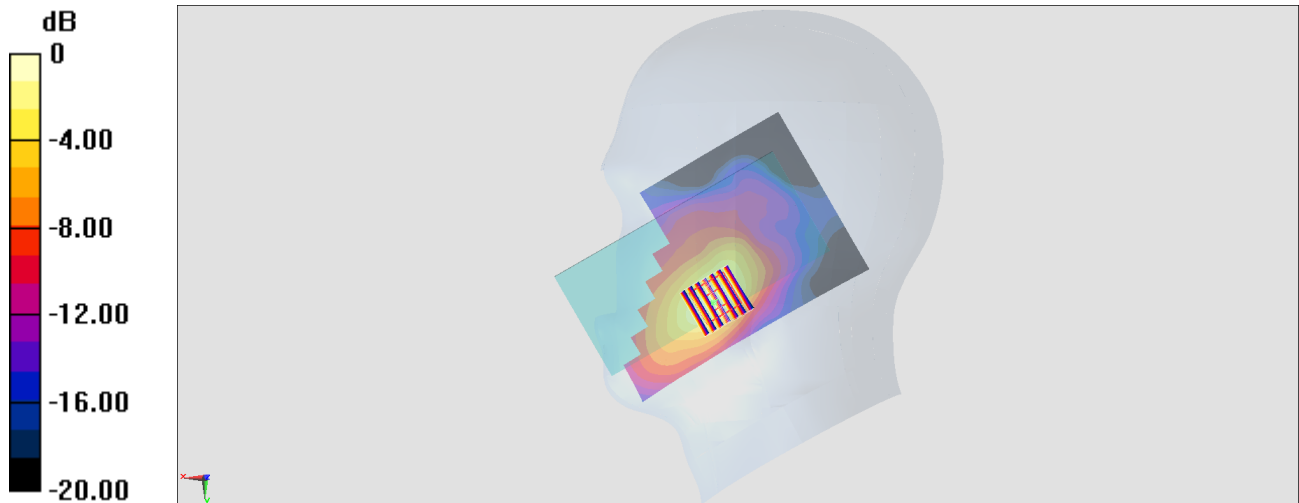

0 dB = 0.902 W/kg = -0.45 dBW/kg

#12_LTE Band 41_20M_QPSK_1_0_Right Cheek_Ch40620

Communication System: LTE ; Frequency: 2593 MHz;Duty Cycle: 1:1.59

Medium: HSL_2600_191107 Medium parameters used : $f = 2593$ MHz; $\sigma = 1.981$ S/m; $\epsilon_r = 38.262$; $\rho = 1000$ kg/m³

Ambient Temperature : 23.4 °C ; Liquid Temperature : 22.4 °C

DASY5 Configuration:

- Probe: EX3DV4 - SN3931; ConvF(7.43, 7.43, 7.43) @ 2593 MHz; Calibrated: 2019/9/26
- Sensor-Surface: 1.4mm (Mechanical Surface Detection)
- Electronics: DAE4 Sn778; Calibrated: 2019/5/21
- Phantom: SAM_Left; Type: QD000P40CD; Serial: TP:1801
- Measurement SW: DASY52, Version 52.10 (2);SEMCAD X Version 14.6.12 (7450)

Area Scan (91x151x1): Interpolated grid: dx=1.200 mm, dy=1.200 mm

Maximum value of SAR (interpolated) = 0.646 W/kg

Zoom Scan (7x7x7)/Cube 0: Measurement grid: dx=5mm, dy=5mm, dz=5mm

Reference Value = 17.53 V/m; Power Drift = 0.06 dB

Peak SAR (extrapolated) = 0.996 W/kg

SAR(1 g) = 0.538 W/kg; SAR(10 g) = 0.279 W/kg

Maximum value of SAR (measured) = 0.669 W/kg

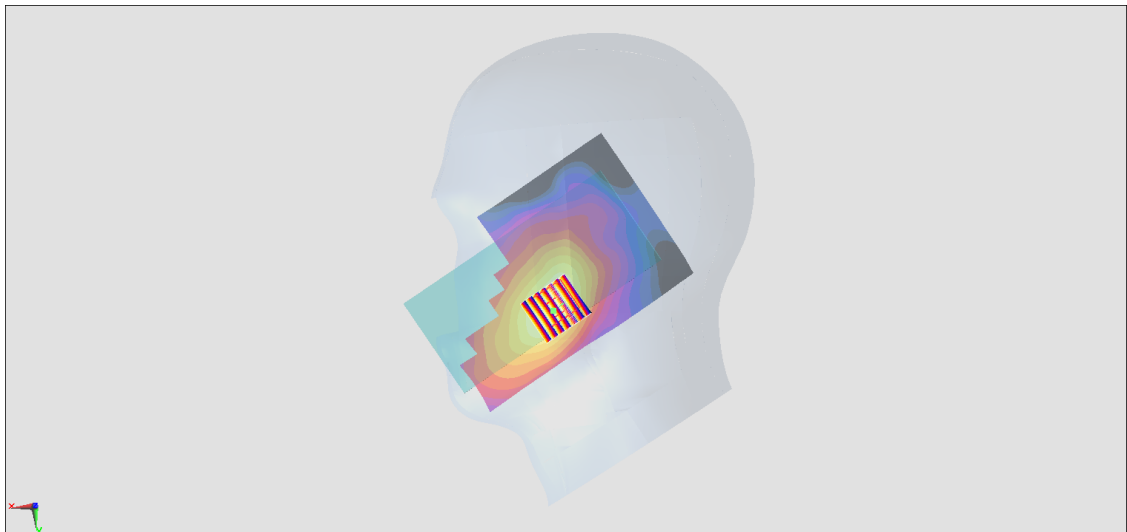
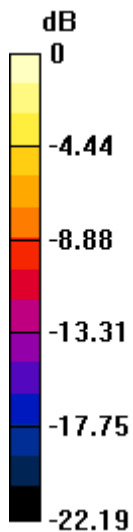

0 dB = 0.669 W/kg = -1.75 dBW/kg

#13_WLAN2.4GHz_802.11b 1Mbps_Left Cheek_0mm_Ch11

Communication System: 802.11b ; Frequency: 2462 MHz; Duty Cycle: 1:1.009

Medium: HSL_2450_191101 Medium parameters used: $f = 2462$ MHz; $\sigma = 1.823$ S/m; $\epsilon_r = 39.002$; $\rho = 1000$ kg/m³

Ambient Temperature : 23.4 °C ; Liquid Temperature : 22.4 °C

DASY5 Configuration:

- Probe: EX3DV4 - SN3925; ConvF(7.6, 7.6, 7.6) @ 2462 MHz; Calibrated: 2019/9/20
- Sensor-Surface: 1.4mm (Mechanical Surface Detection)
- Electronics: DAE4 Sn1399; Calibrated: 2018/11/16
- Phantom: SAM_Left; Type: QD000P40CD; Serial: TP:1801
- Measurement SW: DASY52, Version 52.10 (2); SEMCAD X Version 14.6.12 (7470)

Area Scan (91x81x1): Interpolated grid: dx=1.200 mm, dy=1.200 mm

Maximum value of SAR (interpolated) = 1.23 W/kg

Zoom Scan (7x7x7)/Cube 0: Measurement grid: dx=5mm, dy=5mm, dz=5mm

Reference Value = 24.54 V/m; Power Drift = 0.02 dB

Peak SAR (extrapolated) = 1.60 W/kg

SAR(1 g) = 0.776 W/kg; SAR(10 g) = 0.370 W/kg

Maximum value of SAR (measured) = 1.24 W/kg

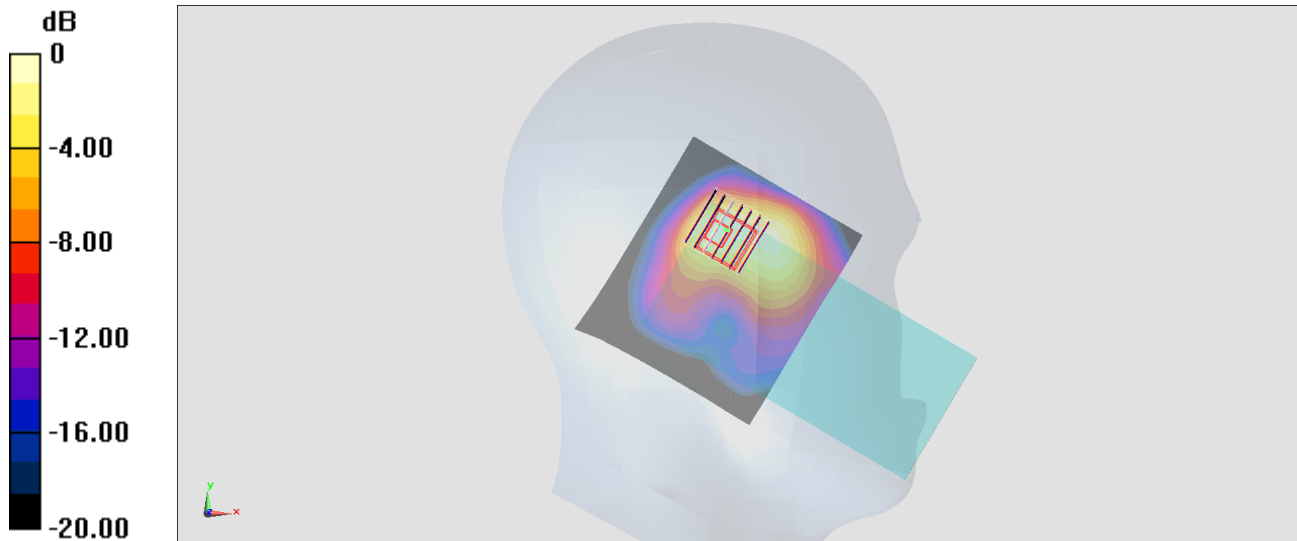

0 dB = 1.23 W/kg = 0.90 dBW/kg

#14_WLAN5GHz_802.11ac-VHT80 MCS0_Left Cheek_Ch58

Communication System: 802.11ac ; Frequency: 5290 MHz;Duty Cycle: 1:1.083

Medium: HSL_5G_191029 Medium parameters used : $f = 5290$ MHz; $\sigma = 4.593$ S/m; $\epsilon_r = 35.962$; $\rho = 1000$ kg/m³

Ambient Temperature : 23.5 °C ; Liquid Temperature : 22.5 °C

DASY5 Configuration:

- Probe: EX3DV4 - SN3925; ConvF(5.49, 5.49, 5.49) @ 5290 MHz; Calibrated: 2019/9/20
- Sensor-Surface: 1.4mm (Mechanical Surface Detection)
- Electronics: DAE4 Sn1399; Calibrated: 2018/11/16
- Phantom: SAM_Right; Type: QD000P40CD; Serial: 1884
- Measurement SW: DASY52, Version 52.10 (2);SEMCAD X Version 14.6.12 (7470)

Area Scan (101x81x1): Interpolated grid: dx=1.000 mm, dy=1.000 mm

Maximum value of SAR (interpolated) = 0.754 W/kg

Zoom Scan (7x7x7)/Cube 0: Measurement grid: dx=4mm, dy=4mm, dz=1.4mm

Reference Value = 9.354 V/m; Power Drift = -0.18 dB

Peak SAR (extrapolated) = 0.858 W/kg

SAR(1 g) = 0.195 W/kg; SAR(10 g) = 0.062 W/kg

Maximum value of SAR (measured) = 0.483 W/kg

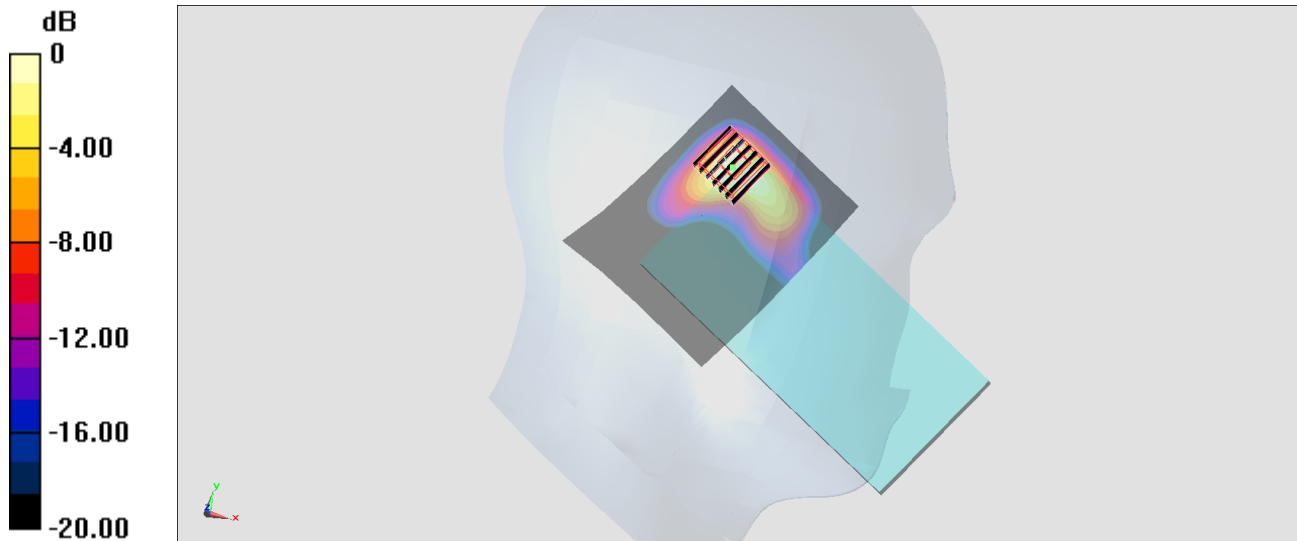

0 dB = 0.483 W/kg = -3.16 dBW/kg

#15_WLAN5GHz_802.11ac-VHT80 MCS0_Left Cheek_Ch106

Communication System: 802.11ac ; Frequency: 5530 MHz;Duty Cycle: 1:1.083

Medium: HSL_5G_191030 Medium parameters used : $f = 5530$ MHz; $\sigma = 4.82$ S/m; $\epsilon_r = 35.643$; $\rho = 1000$ kg/m³

Ambient Temperature : 23.5 °C ; Liquid Temperature : 22.5 °C

DASY5 Configuration:

- Probe: EX3DV4 - SN3925; ConvF(4.89, 4.89, 4.89) @ 5530 MHz; Calibrated: 2019/9/20
- Sensor-Surface: 1.4mm (Mechanical Surface Detection)
- Electronics: DAE4 Sn1399; Calibrated: 2018/11/16
- Phantom: SAM_Right; Type: QD000P40CD; Serial: 1884
- Measurement SW: DASY52, Version 52.10 (2);SEMCAD X Version 14.6.12 (7470)

Area Scan (101x81x1): Interpolated grid: dx=1.000 mm, dy=1.000 mm

Maximum value of SAR (interpolated) = 0.805 W/kg

Zoom Scan (7x7x7)/Cube 0: Measurement grid: dx=4mm, dy=4mm, dz=1.4mm

Reference Value = 7.776 V/m; Power Drift = 0.18 dB

Peak SAR (extrapolated) = 0.876 W/kg

SAR(1 g) = 0.198 W/kg; SAR(10 g) = 0.072 W/kg

Maximum value of SAR (measured) = 0.501 W/kg

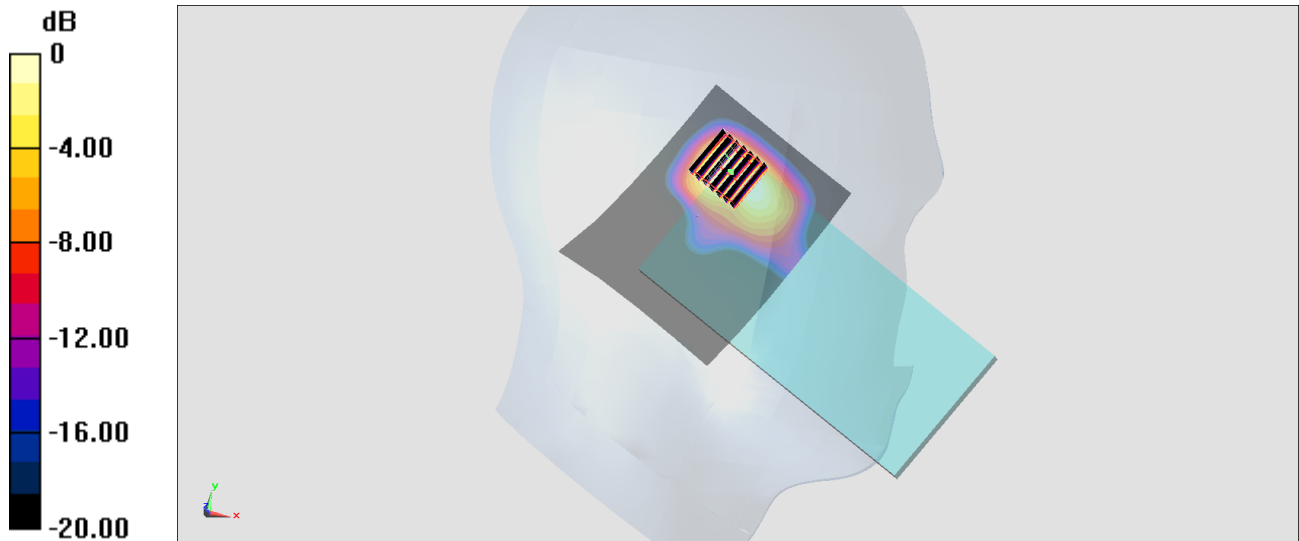

0 dB = 0.501 W/kg = -3.00 dBW/kg

#16_WLAN5GHz_802.11ac-VHT80 MCS0_Left Cheek_Ch155

Communication System: 802.11ac ; Frequency: 5775 MHz;Duty Cycle: 1:1.083

Medium: HSL_5G_191031 Medium parameters used: $f = 5775$ MHz; $\sigma = 5.078$ S/m; $\epsilon_r = 35.32$; $\rho = 1000$ kg/m³

Ambient Temperature : 23.5 °C ; Liquid Temperature : 22.5 °C

DASY5 Configuration:

- Probe: EX3DV4 - SN3925; ConvF(5.22, 5.22, 5.22) @ 5775 MHz; Calibrated: 2019/9/20
- Sensor-Surface: 1.4mm (Mechanical Surface Detection)
- Electronics: DAE4 Sn1399; Calibrated: 2018/11/16
- Phantom: SAM_Right; Type: QD000P40CD; Serial: 1884
- Measurement SW: DASY52, Version 52.10 (2);SEMCAD X Version 14.6.12 (7470)

Area Scan (101x81x1): Interpolated grid: dx=1.000 mm, dy=1.000 mm

Maximum value of SAR (interpolated) = 0.940 W/kg

Zoom Scan (7x7x7)/Cube 0: Measurement grid: dx=4mm, dy=4mm, dz=1.4mm

Reference Value = 9.926 V/m; Power Drift = -0.10 dB

Peak SAR (extrapolated) = 1.84 W/kg

SAR(1 g) = 0.192 W/kg; SAR(10 g) = 0.061 W/kg

Maximum value of SAR (measured) = 0.504 W/kg

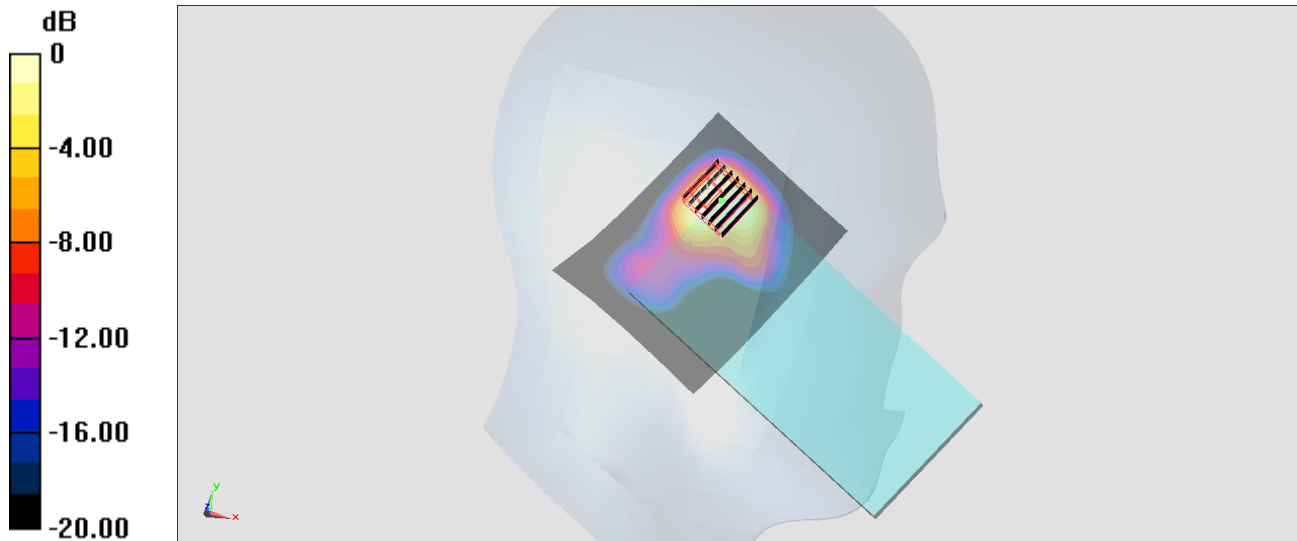

0 dB = 0.504 W/kg = -2.98 dBW/kg

#17_GSM850_GPRS (4 Tx slots)_Back_10mm_Ch251

Communication System: GSM850 ; Frequency: 848.8 MHz;Duty Cycle: 1:2.08
Medium: HSL_850_191104 Medium parameters used: $f = 849$ MHz; $\sigma = 0.899$ S/m; $\epsilon_r = 41.832$; $\rho = 1000$ kg/m³
Ambient Temperature : 23.6 °C ; Liquid Temperature : 22.6 °C

DASY5 Configuration

- Probe: ES3DV3 - SN3270;ConvF(6.43, 6.43, 6.43) @ 848.8 MHz;Calibrated: 2019/9/25
- Sensor-Surface: 3mm (Mechanical Surface Detection)
- Electronics: DAE3 Sn577; Calibrated: 2019/9/17
- Phantom: Twin-SAM V5.0 (30deg probe tilt); Type: QD 000 P40 CD; Serial: 1885
- Measurement SW: DASY52, Version 52.10 (2); SEMCAD X Version 14.6.12 (7450)

Area Scan (71x121x1): Interpolated grid: dx=1.500 mm, dy=1.500 mm
Maximum value of SAR (interpolated) = 0.407 W/kg

Zoom Scan (5x5x7)/Cube 0: Measurement grid: dx=8mm, dy=8mm, dz=5mm
Reference Value = 18.54 V/m; Power Drift = 0.16 dB
Peak SAR (extrapolated) = 0.601 W/kg
SAR(1 g) = 0.317 W/kg; SAR(10 g) = 0.183 W/kg
Maximum value of SAR (measured) = 0.397 W/kg

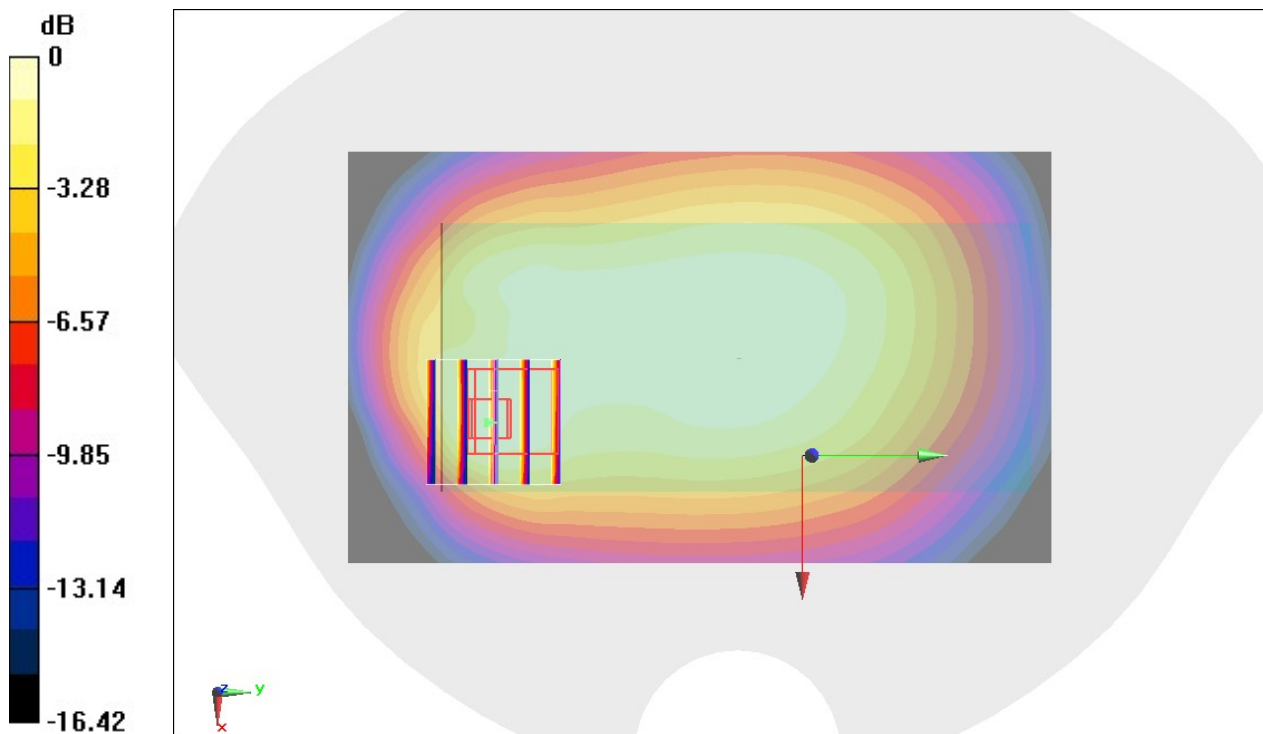

0 dB = 0.397 W/kg = -4.01 dBW/kg

#18_GSM1900_GPRS (4 Tx slots)_Back_10mm_Ch512

Communication System: PCS ; Frequency: 1850.2 MHz;Duty Cycle: 1:2.08
Medium: HSL_1900_191104 Medium parameters used : $f = 1850.2$ MHz; $\sigma = 1.352$ S/m; $\epsilon_r = 40.806$; $\rho = 1000$ kg/m³
Ambient Temperature : 23.6 °C ; Liquid Temperature : 22.6 °C

DASY5 Configuration

- Probe: ES3DV3 - SN3270;ConvF(5.2, 5.2, 5.2) @ 1850.2 MHz;Calibrated: 2019/9/25
- Sensor-Surface: 3mm (Mechanical Surface Detection)
- Electronics: DAE3 Sn577; Calibrated: 2019/9/17
- Phantom: Twin-SAM V5.0 (30deg probe tilt); Type: QD 000 P40 CD; Serial: 1885
- Measurement SW: DASY52, Version 52.10 (2); SEMCAD X Version 14.6.12 (7450)

Area Scan (71x81x1): Interpolated grid: dx=1.500 mm, dy=1.500 mm
Maximum value of SAR (interpolated) = 1.00 W/kg

Zoom Scan (5x5x7)/Cube 0: Measurement grid: dx=8mm, dy=8mm, dz=5mm
Reference Value = 22.46 V/m; Power Drift = -0.04 dB
Peak SAR (extrapolated) = 1.44 W/kg
SAR(1 g) = 0.827 W/kg; SAR(10 g) = 0.457 W/kg
Maximum value of SAR (measured) = 1.03 W/kg

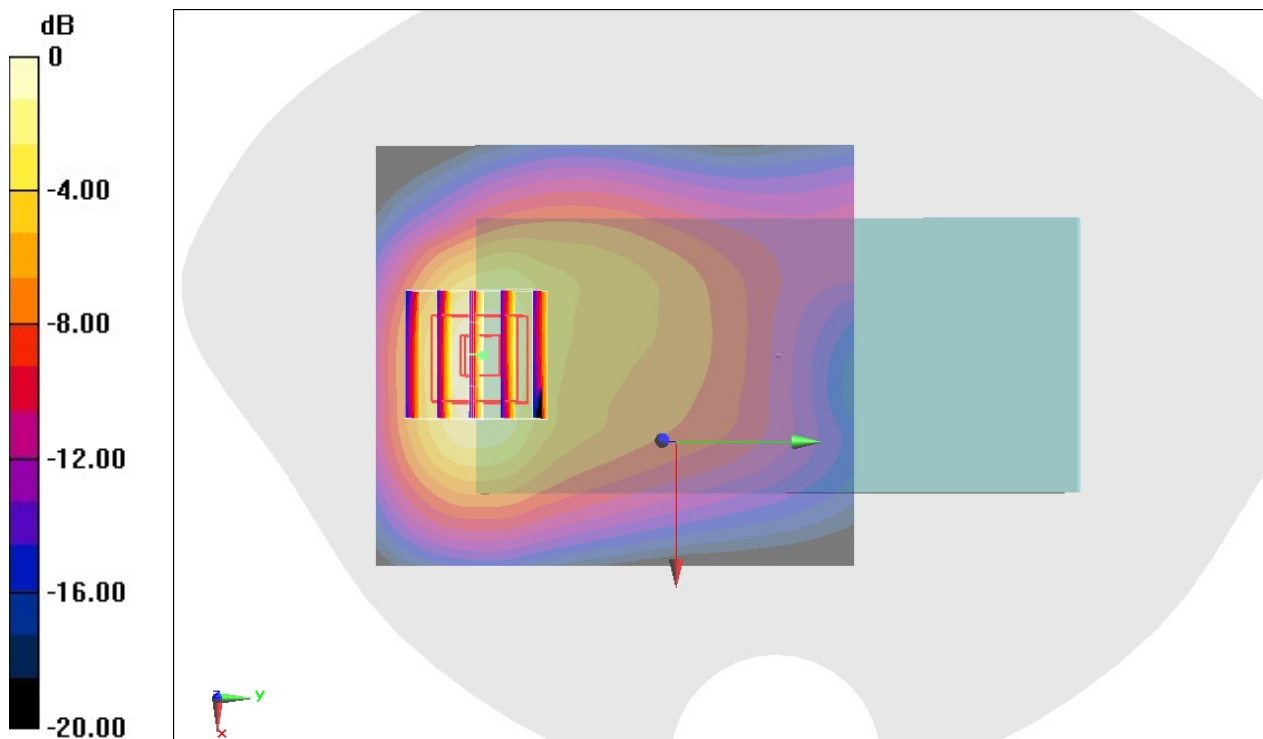

0 dB = 1.03 W/kg = 0.13 dBW/kg

#19_WCDMA II_RMC 12.2Kbps_Back_10mm_Ch9538

Communication System: WCDMA; Frequency: 1907.6 MHz; Duty Cycle: 1:1

Medium: HSL_1900_191029 Medium parameters used: $f = 1908$ MHz; $\sigma = 1.445$ S/m; $\epsilon_r = 39.466$; $\rho = 1000$ kg/m³

Ambient Temperature : 23.6 °C ; Liquid Temperature : 22.6 °C

DASY5 Configuration:

- Probe: ES3DV3 - SN3184; ConvF(5.23, 5.23, 5.23) @ 1907.6 MHz; Calibrated: 2019/9/25
- Sensor-Surface: 3mm (Mechanical Surface Detection)
- Electronics: DAE3 Sn495; Calibrated: 2019/5/21
- Phantom: SAM LEFT; Type: QD000P40CD; Serial: TP:1718
- Measurement SW: DASY52, Version 52.10 (2); SEMCAD X Version 14.6.12 (7470)

Area Scan (61x121x1): Interpolated grid: dx=1.500 mm, dy=1.500 mm

Maximum value of SAR (interpolated) = 1.41 W/kg

Zoom Scan (5x5x7)/Cube 0: Measurement grid: dx=8mm, dy=8mm, dz=5mm

Reference Value = 25.80 V/m; Power Drift = -0.00 dB

Peak SAR (extrapolated) = 1.90 W/kg

SAR(1 g) = 1 W/kg; SAR(10 g) = 0.542 W/kg

Maximum value of SAR (measured) = 1.24 W/kg

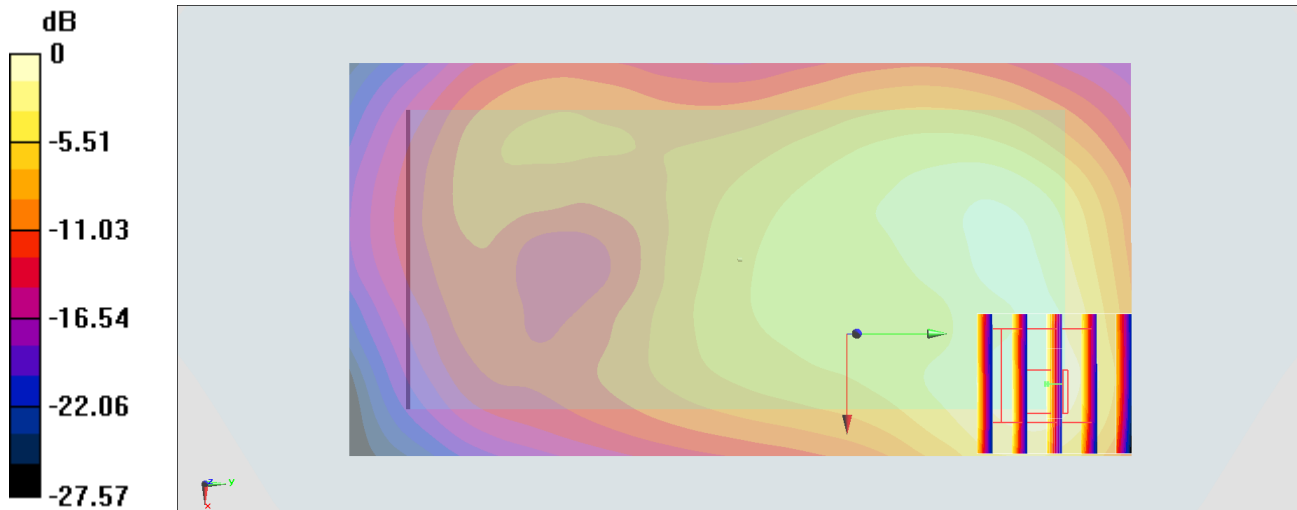

0 dB = 1.41 W/kg = 1.49 dBW/kg

#20_WCDMA IV_RMC 12.2Kbps_Bottom Side_10mm_Ch1312

Communication System: WCDMA; Frequency: 1712.4 MHz; Duty Cycle: 1:1

Medium: HSL_1750_191029 Medium parameters used: $f = 1712.4$ MHz; $\sigma = 1.328$ S/m; $\epsilon_r = 40.286$; $\rho = 1000$ kg/m³

Ambient Temperature : 23.6 °C ; Liquid Temperature : 22.6 °C

DASY5 Configuration:

- Probe: ES3DV3 - SN3184; ConvF(5.45, 5.45, 5.45) @ 1712.4 MHz; Calibrated: 2019/9/25
- Sensor-Surface: 3mm (Mechanical Surface Detection)
- Electronics: DAE3 Sn495; Calibrated: 2019/5/21
- Phantom: SAM LEFT; Type: QD000P40CD; Serial: TP:1718
- Measurement SW: DASY52, Version 52.10 (2); SEMCAD X Version 14.6.12 (7470)

Area Scan (41x61x1): Interpolated grid: dx=1.500 mm, dy=1.500 mm

Maximum value of SAR (interpolated) = 0.928 W/kg

Zoom Scan (5x5x7)/Cube 0: Measurement grid: dx=8mm, dy=8mm, dz=5mm

Reference Value = 26.78 V/m; Power Drift = -0.08 dB

Peak SAR (extrapolated) = 1.22 W/kg

SAR(1 g) = 0.739 W/kg; SAR(10 g) = 0.421 W/kg

Maximum value of SAR (measured) = 0.897 W/kg

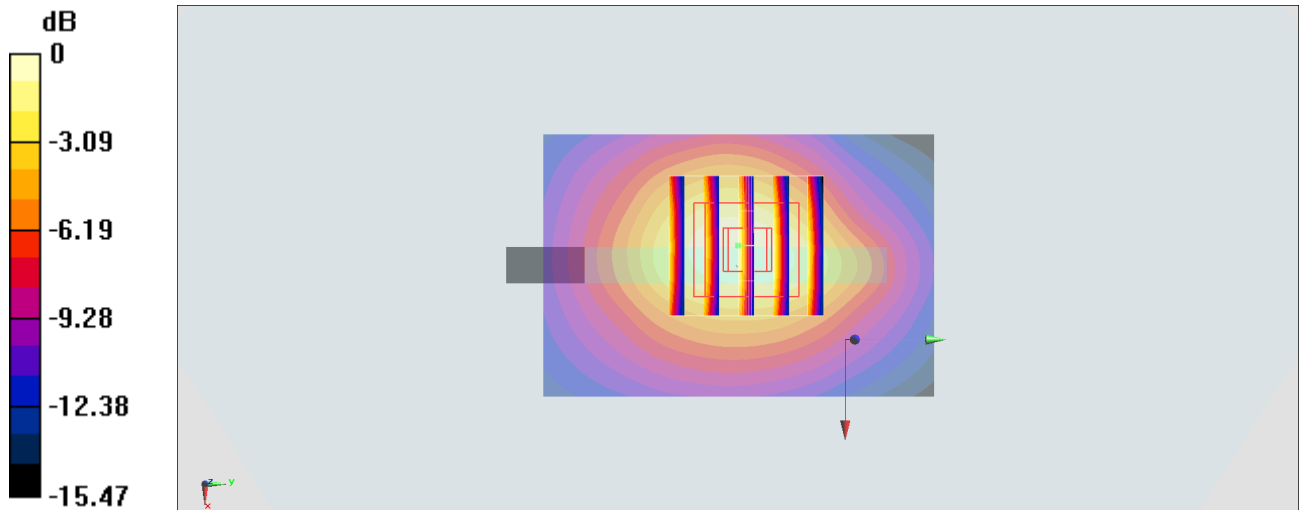

0 dB = 0.928 W/kg = -0.32 dBW/kg

#21_WCDMA V_RMC 12.2Kbps_Back_10mm_Ch4182

Communication System: WCDMA ; Frequency: 836.4 MHz;Duty Cycle: 1:1
Medium: HSL_850_191104 Medium parameters used : $f = 836.4$ MHz; $\sigma = 0.882$ S/m; $\epsilon_r = 41.914$;
 $\rho = 1000$ kg/m³
Ambient Temperature : 23.6 °C ; Liquid Temperature : 22.6 °C

DASY5 Configuration

- Probe: ES3DV3 - SN3270;ConvF(6.43, 6.43, 6.43) @ 836.4 MHz;Calibrated: 2019/9/25
- Sensor-Surface: 3mm (Mechanical Surface Detection)
- Electronics: DAE3 Sn577; Calibrated: 2019/9/17
- Phantom: Twin-SAM V5.0 (30deg probe tilt); Type: QD 000 P40 CD; Serial: 1885
- Measurement SW: DASY52, Version 52.10 (2); SEMCAD X Version 14.6.12 (7450)

Area Scan (71x121x1): Interpolated grid: dx=1.500 mm, dy=1.500 mm
Maximum value of SAR (interpolated) = 0.312 W/kg

Zoom Scan (5x5x7)/Cube 0: Measurement grid: dx=8mm, dy=8mm, dz=5mm
Reference Value = 18.11 V/m; Power Drift = -0.01 dB
Peak SAR (extrapolated) = 0.374 W/kg
SAR(1 g) = 0.296 W/kg; SAR(10 g) = 0.227 W/kg
Maximum value of SAR (measured) = 0.324 W/kg

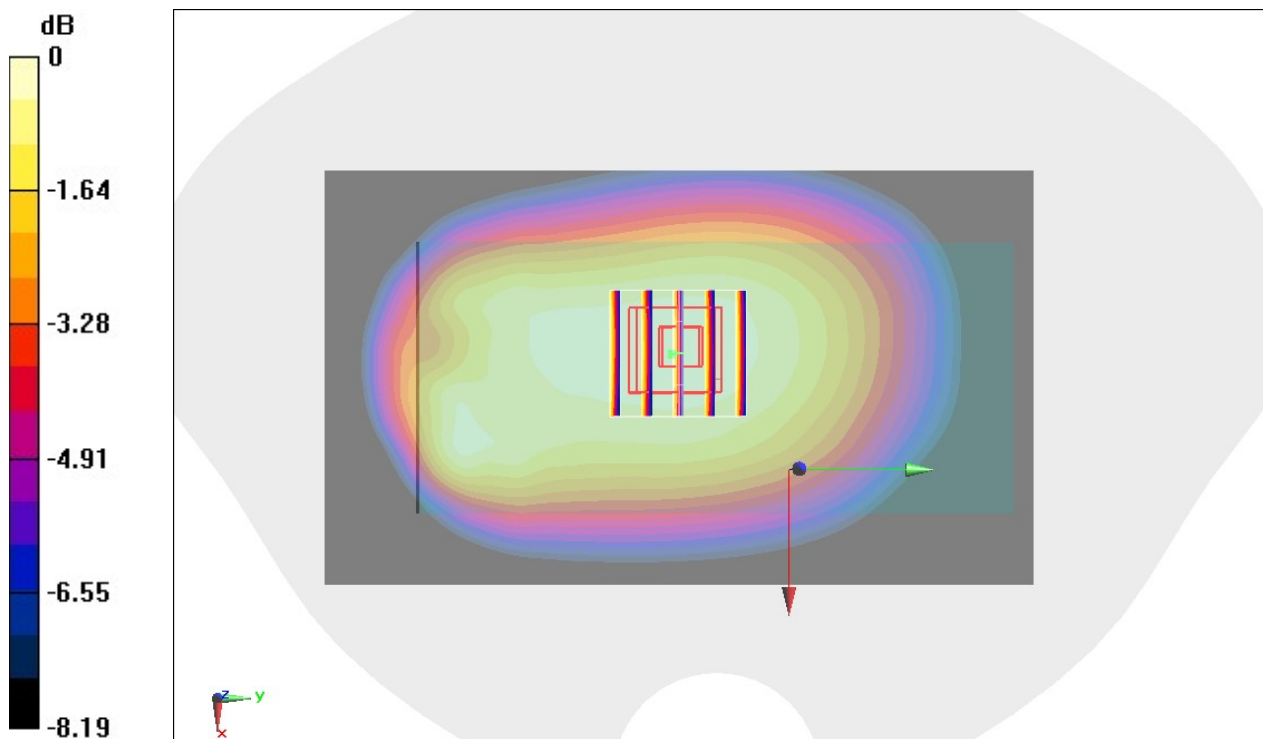

0 dB = 0.324 W/kg = -4.89 dBW/kg

#22_CDMA BC0_RTAP 153.6Kbps_Back_10mm_Ch1013

Communication System: CDMA ; Frequency: 824.7 MHz; Duty Cycle: 1:1

Medium: HSL_850_191031 Medium parameters used: $f = 825$ MHz; $\sigma = 0.9$ S/m; $\epsilon_r = 41.621$; $\rho = 1000$ kg/m³

Ambient Temperature : 23.5 °C ; Liquid Temperature : 22.5 °C

DASY5 Configuration:

- Probe: ES3DV3 - SN3184; ConvF(6.41, 6.41, 6.41) @ 824.7 MHz; Calibrated: 2019/9/25
- Sensor-Surface: 3mm (Mechanical Surface Detection)
- Electronics: DAE3 Sn495; Calibrated: 2019/5/21
- Phantom: SAM_Front; Type: QD000P40CD; Serial: 1719
- Measurement SW: DASY52, Version 52.10 (2); SEMCAD X Version 14.6.12 (7470)

Area Scan (71x121x1): Interpolated grid: dx=1.500 mm, dy=1.500 mm

Maximum value of SAR (interpolated) = 0.194 W/kg

Zoom Scan (5x5x7)/Cube 0: Measurement grid: dx=8mm, dy=8mm, dz=5mm

Reference Value = 13.78 V/m; Power Drift = -0.01 dB

Peak SAR (extrapolated) = 0.291 W/kg

SAR(1 g) = 0.157 W/kg; SAR(10 g) = 0.092 W/kg

Maximum value of SAR (measured) = 0.193 W/kg

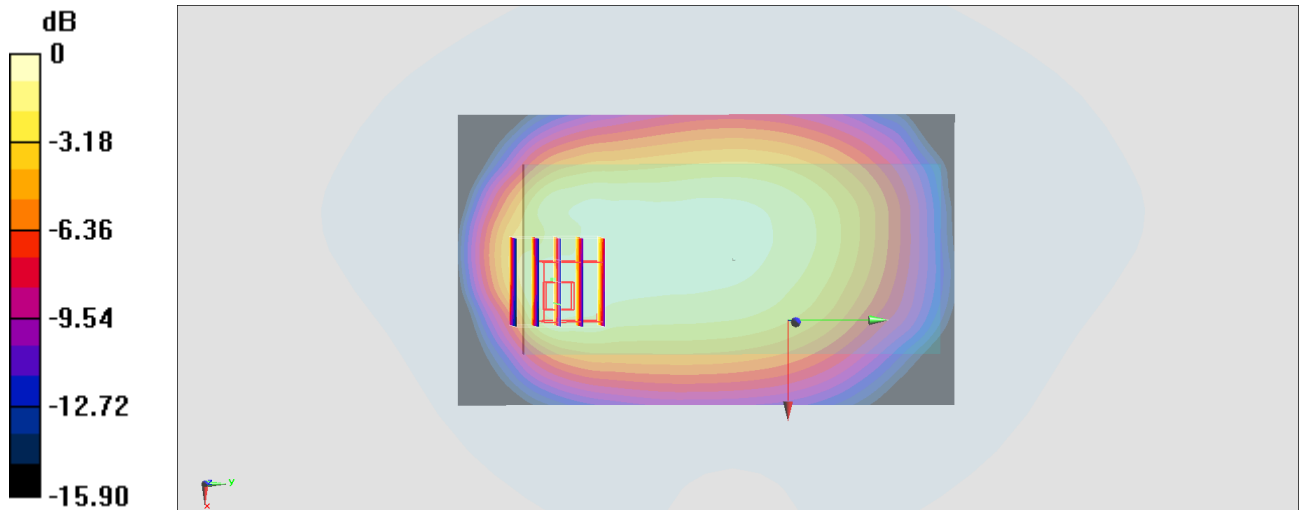

0 dB = 0.193 W/kg = -7.14 dBW/kg

#23_CDMA BC1_RTAP 153.6Kbps_Back_10mm_Ch1175

Communication System: CDMA ; Frequency: 1908.75 MHz; Duty Cycle: 1:1

Medium: HSL_1900_191030 Medium parameters used: $f = 1909$ MHz; $\sigma = 1.434$ S/m; $\epsilon_r = 39.352$; $\rho = 1000$ kg/m³

Ambient Temperature : 23.2 °C ; Liquid Temperature : 22.2 °C

DASY5 Configuration:

- Probe: ES3DV3 - SN3184; ConvF(5.23, 5.23, 5.23) @ 1908.75 MHz; Calibrated: 2019/9/25
- Sensor-Surface: 3mm (Mechanical Surface Detection)
- Electronics: DAE3 Sn495; Calibrated: 2019/5/21
- Phantom: SAM LEFT; Type: QD000P40CD; Serial: TP:1718
- Measurement SW: DASY52, Version 52.10 (2); SEMCAD X Version 14.6.12 (7470)

Area Scan (71x61x1): Interpolated grid: dx=1.500 mm, dy=1.500 mm

Maximum value of SAR (interpolated) = 1.17 W/kg

Zoom Scan (5x5x7)/Cube 0: Measurement grid: dx=8mm, dy=8mm, dz=5mm

Reference Value = 25.02 V/m; Power Drift = -0.06 dB

Peak SAR (extrapolated) = 1.58 W/kg

SAR(1 g) = 0.828 W/kg; SAR(10 g) = 0.449 W/kg

Maximum value of SAR (measured) = 0.999 W/kg

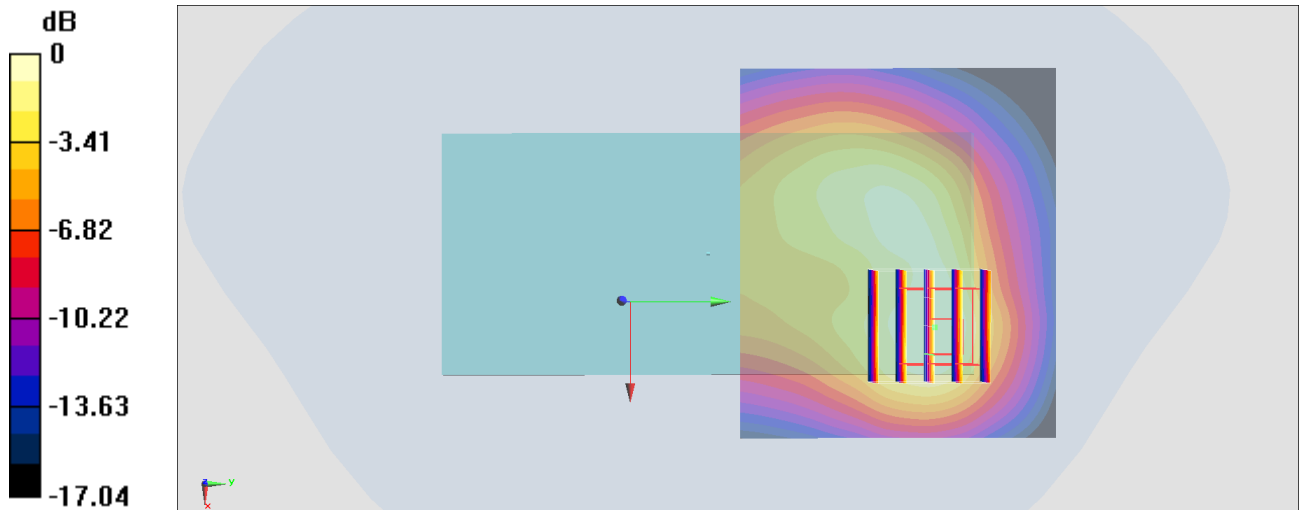

0 dB = 0.999 W/kg = -0.00 dBW/kg

#24_CDMA BC10_RTAP 153.6Kbps_Back_10mm_Ch580

Communication System: CDMA ; Frequency: 820.5 MHz;Duty Cycle: 1:1

Medium: HSL_850_191031 Medium parameters used : $f = 820.5$ MHz; $\sigma = 0.898$ S/m; $\epsilon_r = 41.566$; $\rho = 1000$ kg/m³

Ambient Temperature : 23.5 °C ; Liquid Temperature : 22.5 °C

DASY5 Configuration:

- Probe: ES3DV3 - SN3184; ConvF(6.41, 6.41, 6.41) @ 820.5 MHz; Calibrated: 2019/9/25
- Sensor-Surface: 3mm (Mechanical Surface Detection)
- Electronics: DAE3 Sn495; Calibrated: 2019/5/21
- Phantom: SAM_Front; Type: QD000P40CD; Serial: 1719
- Measurement SW: DASY52, Version 52.10 (2);SEMCAD X Version 14.6.12 (7470)

Area Scan (71x121x1): Interpolated grid: dx=1.500 mm, dy=1.500 mm

Maximum value of SAR (interpolated) = 0.193 W/kg

Zoom Scan (5x5x7)/Cube 0: Measurement grid: dx=8mm, dy=8mm, dz=5mm

Reference Value = 14.71 V/m; Power Drift = -0.06 dB

Peak SAR (extrapolated) = 0.283 W/kg

SAR(1 g) = 0.163 W/kg; SAR(10 g) = 0.099 W/kg

Maximum value of SAR (measured) = 0.194 W/kg

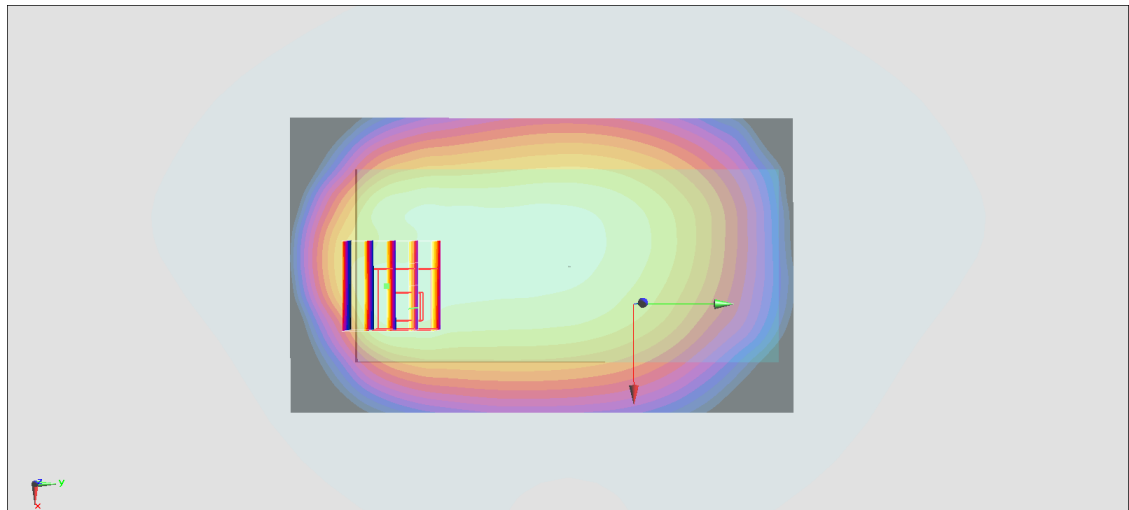
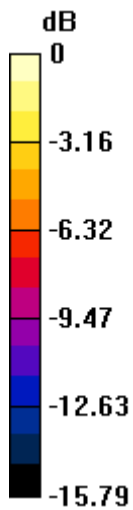

0 dB = 0.194 W/kg = -7.12 dBW/kg

#25_LTE Band 7_20M_QPSK_1_0_Back_10mm_Ch21350

Communication System: LTE ; Frequency: 2560 MHz;Duty Cycle: 1:1

Medium: HSL_2600_191105 Medium parameters used: $f = 2560$ MHz; $\sigma = 1.917$ S/m; $\epsilon_r = 39.033$; $\rho = 1000$ kg/m³

Ambient Temperature : 23.4 °C ; Liquid Temperature : 22.4 °C

DASY5 Configuration:

- Probe: EX3DV4 - SN3931; ConvF(7.43, 7.43, 7.43) @ 2560 MHz; Calibrated: 2019/9/26
- Sensor-Surface: 1.4mm (Mechanical Surface Detection)
- Electronics: DAE4 Sn778; Calibrated: 2019/5/21
- Phantom: SAM_Left; Type: QD000P40CD; Serial: TP:1801
- Measurement SW: DASY52, Version 52.10 (2);SEMCAD X Version 14.6.12 (7450)

Area Scan (91x101x1): Interpolated grid: dx=1.200 mm, dy=1.200 mm

Maximum value of SAR (interpolated) = 1.32 W/kg

Zoom Scan (7x7x7)/Cube 0: Measurement grid: dx=5mm, dy=5mm, dz=5mm

Reference Value = 23.03 V/m; Power Drift = 0.10 dB

Peak SAR (extrapolated) = 1.62 W/kg

SAR(1 g) = 0.818 W/kg; SAR(10 g) = 0.423 W/kg

Maximum value of SAR (measured) = 1.31 W/kg

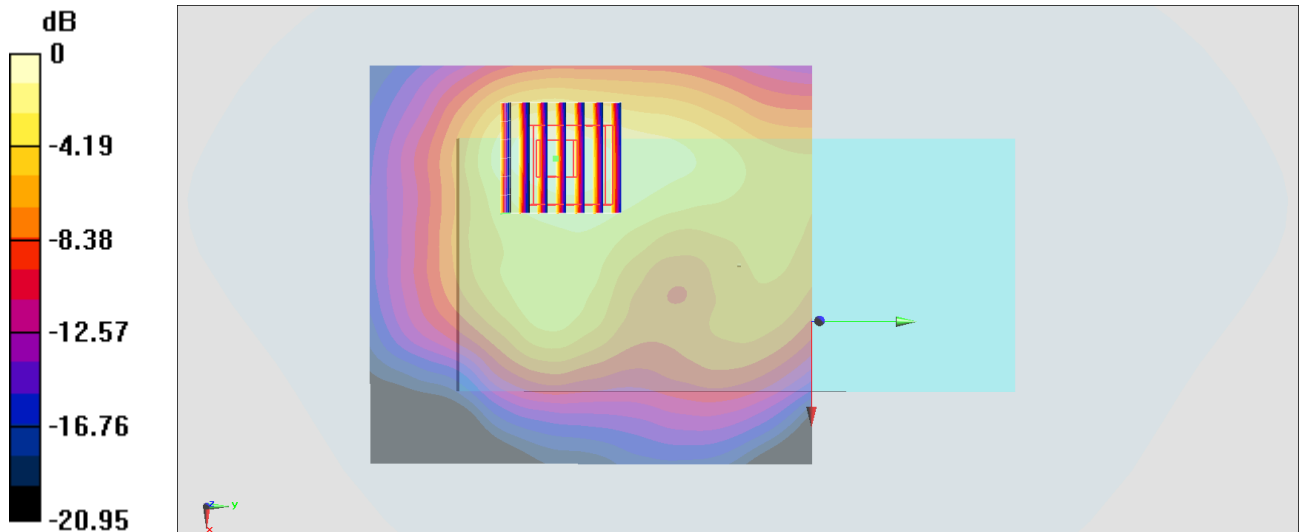

#26_LTE Band 12_10M_QPSK_1_0_Back_10mm_Ch23095

Communication System: LTE ; Frequency: 707.5 MHz; Duty Cycle: 1:1

Medium: HSL_750_191107 Medium parameters used : $f = 707.5$ MHz; $\sigma = 0.865$ S/m; $\epsilon_r = 42.738$; $\rho = 1000$ kg/m³

Ambient Temperature : 23.6 °C ; Liquid Temperature : 22.6 °C

DASY5 Configuration:

- Probe: EX3DV4 - SN3642; ConvF(9.16, 9.16, 9.16) @ 707.5 MHz; Calibrated: 2019/4/29
- Sensor-Surface: 1.4mm (Mechanical Surface Detection)
- Electronics: DAE4 Sn1399; Calibrated: 2018/11/16
- Phantom: SAM_Left; Type: QD000P40CD; Serial: TP:1801
- Measurement SW: DASY52, Version 52.10 (2); SEMCAD X Version 14.6.12 (7470)

Area Scan (71x121x1): Interpolated grid: dx=1.500 mm, dy=1.500 mm

Maximum value of SAR (interpolated) = 0.442 W/kg

Zoom Scan (5x5x7)/Cube 0: Measurement grid: dx=8mm, dy=8mm, dz=5mm

Reference Value = 22.66 V/m; Power Drift = -0.01 dB

Peak SAR (extrapolated) = 0.523 W/kg

SAR(1 g) = 0.311 W/kg; SAR(10 g) = 0.203 W/kg

Maximum value of SAR (measured) = 0.421 W/kg

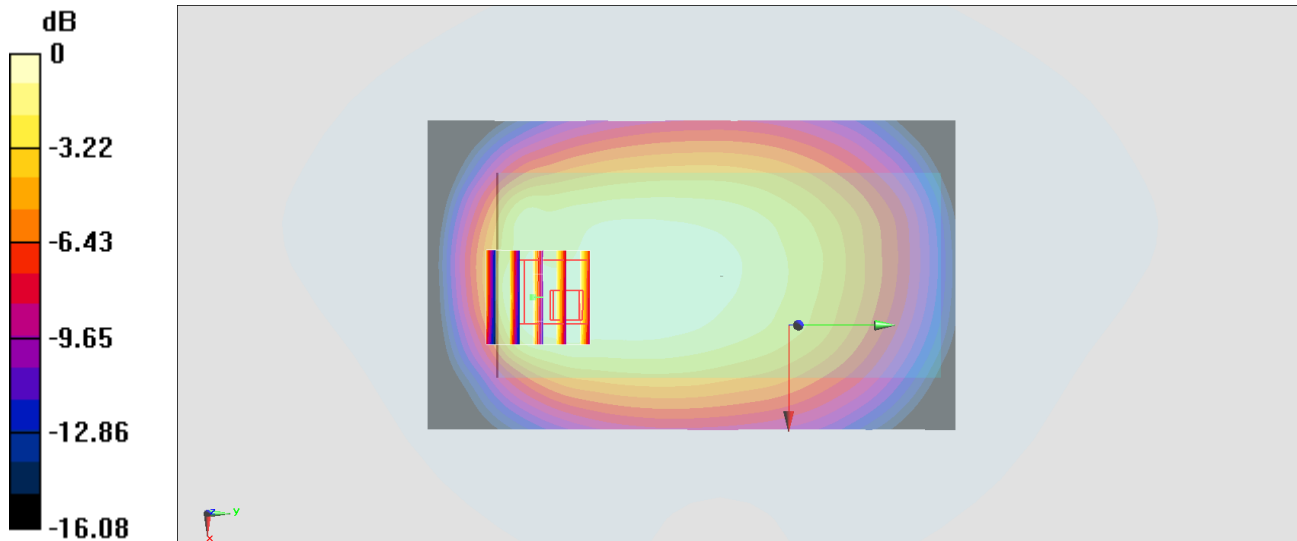

0 dB = 0.421 W/kg = -3.76 dBW/kg

#27_LTE Band 13_10M_QPSK_1_0_Right Side_10mm_Ch23230

Communication System: LTE ; Frequency: 782 MHz;Duty Cycle: 1:1

Medium: HSL_750_191107 Medium parameters used: $f = 782$ MHz; $\sigma = 0.915$ S/m; $\epsilon_r = 41.68$; $\rho = 1000$ kg/m³

Ambient Temperature : 23.6 °C ; Liquid Temperature : 22.6 °C

DASY5 Configuration:

- Probe: EX3DV4 - SN3642; ConvF(9.16, 9.16, 9.16) @ 782 MHz; Calibrated: 2019/4/29
- Sensor-Surface: 1.4mm (Mechanical Surface Detection)
- Electronics: DAE4 Sn1399; Calibrated: 2018/11/16
- Phantom: SAM_Left; Type: QD000P40CD; Serial: TP:1801
- Measurement SW: DASY52, Version 52.10 (2);SEMCAD X Version 14.6.12 (7470)

Area Scan (41x121x1): Interpolated grid: dx=1.500 mm, dy=1.500 mm

Maximum value of SAR (interpolated) = 0.351 W/kg

Zoom Scan (5x5x7)/Cube 0: Measurement grid: dx=8mm, dy=8mm, dz=5mm

Reference Value = 21.97 V/m; Power Drift = -0.11 dB

Peak SAR (extrapolated) = 0.428 W/kg

SAR(1 g) = 0.304 W/kg; SAR(10 g) = 0.214 W/kg

Maximum value of SAR (measured) = 0.387 W/kg

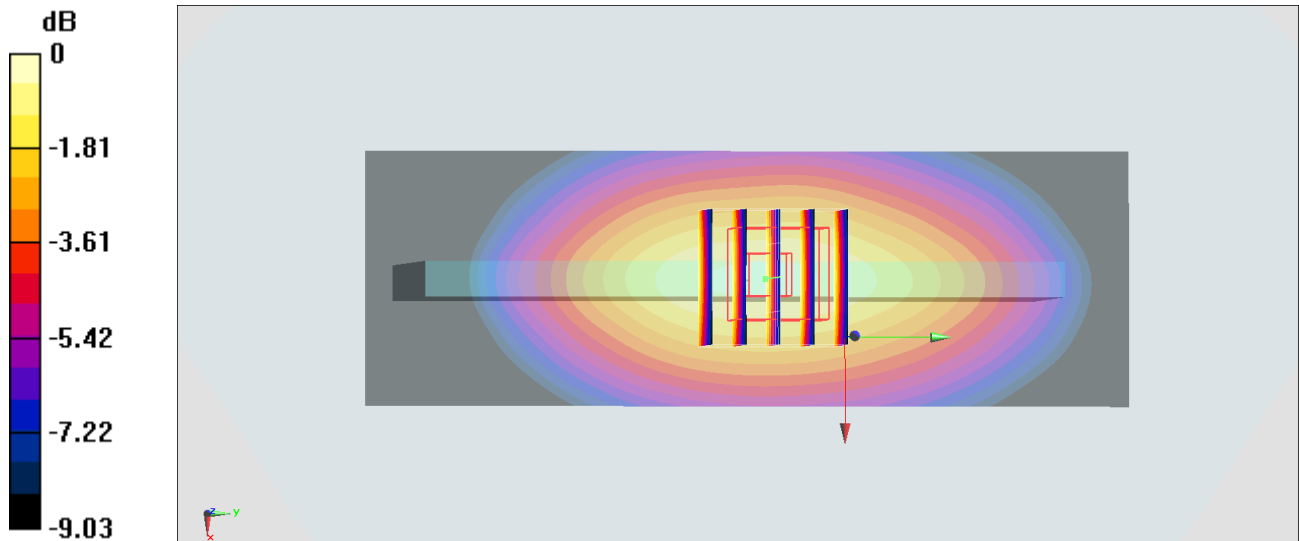

0 dB = 0.387 W/kg = -4.12 dBW/kg

#28_LTE Band 14_10M_QPSK_1_0_Back_10mm_Ch23330

Communication System: LTE ; Frequency: 793 MHz; Duty Cycle: 1:1

Medium: HSL_750_191107 Medium parameters used: $f = 793$ MHz; $\sigma = 0.932$ S/m; $\epsilon_r = 41.517$; $\rho = 1000$ kg/m³

Ambient Temperature : 23.6 °C ; Liquid Temperature : 22.6 °C

DASY5 Configuration:

- Probe: EX3DV4 - SN3642; ConvF(9.16, 9.16, 9.16) @ 793 MHz; Calibrated: 2019/4/29
- Sensor-Surface: 1.4mm (Mechanical Surface Detection)
- Electronics: DAE4 Sn1399; Calibrated: 2018/11/16
- Phantom: SAM_Left; Type: QD000P40CD; Serial: TP:1801
- Measurement SW: DASY52, Version 52.10 (2); SEMCAD X Version 14.6.12 (7470)

Area Scan (71x121x1): Interpolated grid: dx=1.500 mm, dy=1.500 mm

Maximum value of SAR (interpolated) = 0.468 W/kg

Zoom Scan (5x5x7)/Cube 0: Measurement grid: dx=8mm, dy=8mm, dz=5mm

Reference Value = 20.51 V/m; Power Drift = -0.01 dB

Peak SAR (extrapolated) = 0.551 W/kg

SAR(1 g) = 0.290 W/kg; SAR(10 g) = 0.174 W/kg

Maximum value of SAR (measured) = 0.432 W/kg

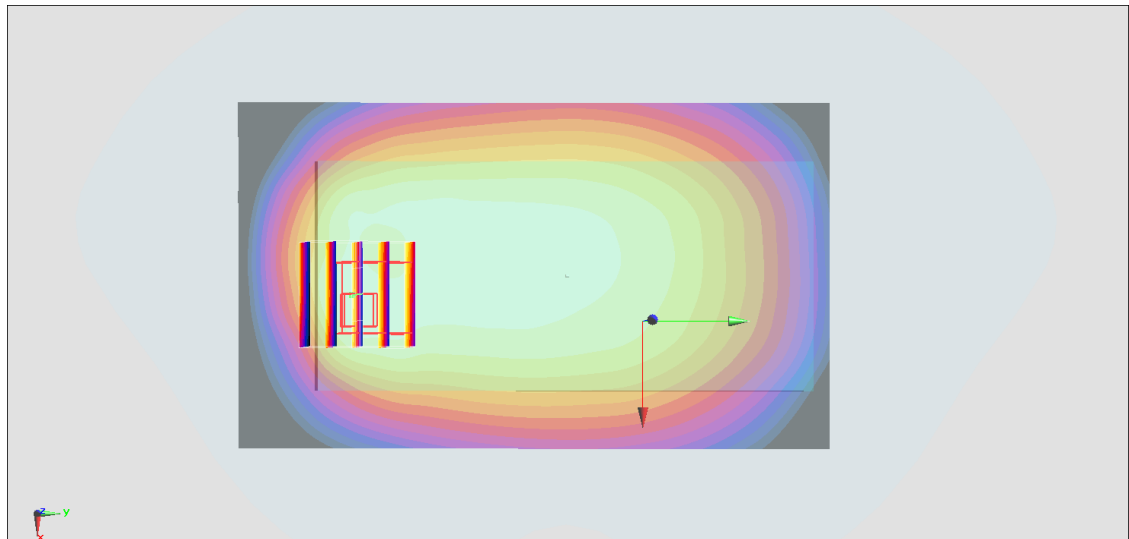
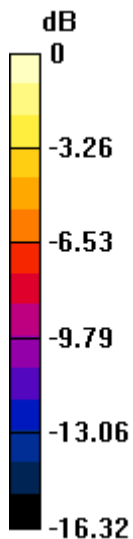

0 dB = 0.432 W/kg = -3.65 dBW/kg

#29_LTE Band 25_20M_QPSK_1_0_Back_10mm_Ch26590

Communication System: LTE; Frequency: 1905 MHz; Duty Cycle: 1:1

Medium: HSL_1900_191029 Medium parameters used: $f = 1905$ MHz; $\sigma = 1.442$ S/m; $\epsilon_r = 39.477$; $\rho = 1000$ kg/m³

Ambient Temperature : 23.6 °C; Liquid Temperature : 22.6 °C

DASY5 Configuration:

- Probe: ES3DV3 - SN3184; ConvF(5.23, 5.23, 5.23) @ 1905 MHz; Calibrated: 2019/9/25
- Sensor-Surface: 3mm (Mechanical Surface Detection)
- Electronics: DAE3 Sn495; Calibrated: 2019/5/21
- Phantom: SAM LEFT; Type: QD000P40CD; Serial: TP:1718
- Measurement SW: DASY52, Version 52.10 (2); SEMCAD X Version 14.6.12 (7470)

Area Scan (61x121x1): Interpolated grid: dx=1.500 mm, dy=1.500 mm

Maximum value of SAR (interpolated) = 1.26 W/kg

Zoom Scan (5x5x7)/Cube 0: Measurement grid: dx=8mm, dy=8mm, dz=5mm

Reference Value = 23.44 V/m; Power Drift = 0.02 dB

Peak SAR (extrapolated) = 1.72 W/kg

SAR(1 g) = 0.923 W/kg; SAR(10 g) = 0.491 W/kg

Maximum value of SAR (measured) = 1.16 W/kg

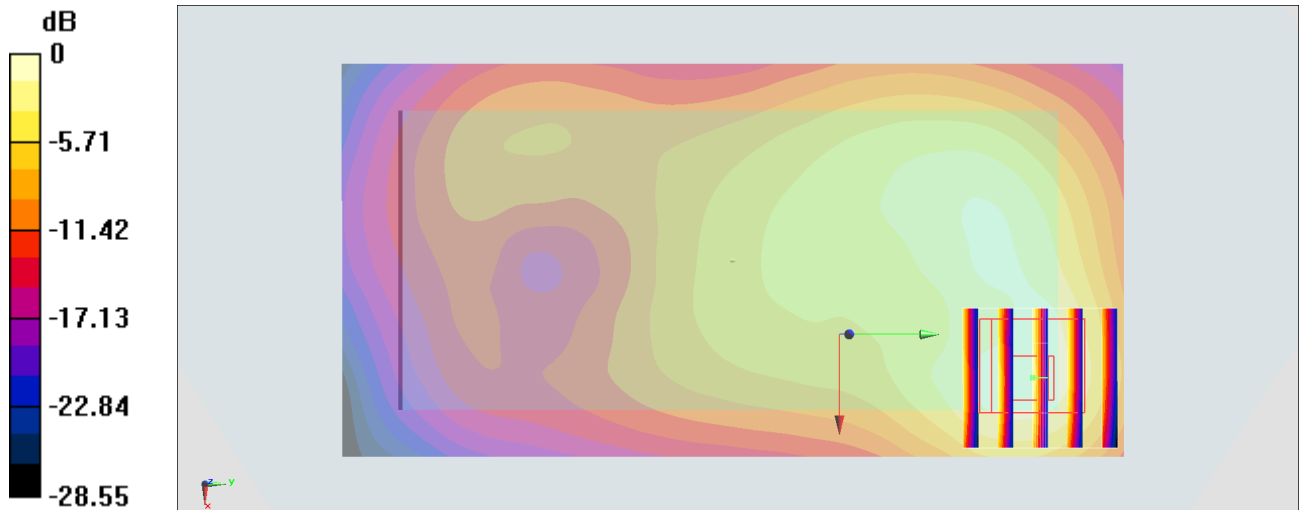

0 dB = 1.26 W/kg = 1.00 dBW/kg

#30_LTE Band 26_15M_QPSK_1_0_Back_10mm_Ch26865

Communication System: LTE; Frequency: 831.5 MHz; Duty Cycle: 1:1

Medium: HSL_850_191031 Medium parameters used : $f = 831.5$ MHz; $\sigma = 0.905$ S/m; $\epsilon_r = 41.466$; $\rho = 1000$ kg/m³

Ambient Temperature : 23.5 °C ; Liquid Temperature : 22.5 °C

DASY5 Configuration:

- Probe: ES3DV3 - SN3184; ConvF(6.41, 6.41, 6.41) @ 831.5 MHz; Calibrated: 2019/9/25
- Sensor-Surface: 3mm (Mechanical Surface Detection)
- Electronics: DAE3 Sn495; Calibrated: 2019/5/21
- Phantom: SAM_Front; Type: QD000P40CD; Serial: 1719
- Measurement SW: DASY52, Version 52.10 (2); SEMCAD X Version 14.6.12 (7470)

Area Scan (71x121x1): Interpolated grid: dx=1.500 mm, dy=1.500 mm

Maximum value of SAR (interpolated) = 0.221 W/kg

Zoom Scan (6x6x7)/Cube 0: Measurement grid: dx=8mm, dy=8mm, dz=5mm

Reference Value = 15.43 V/m; Power Drift = -0.06 dB

Peak SAR (extrapolated) = 0.312 W/kg

SAR(1 g) = 0.125 W/kg; SAR(10 g) = 0.106 W/kg

Maximum value of SAR (measured) = 0.206 W/kg

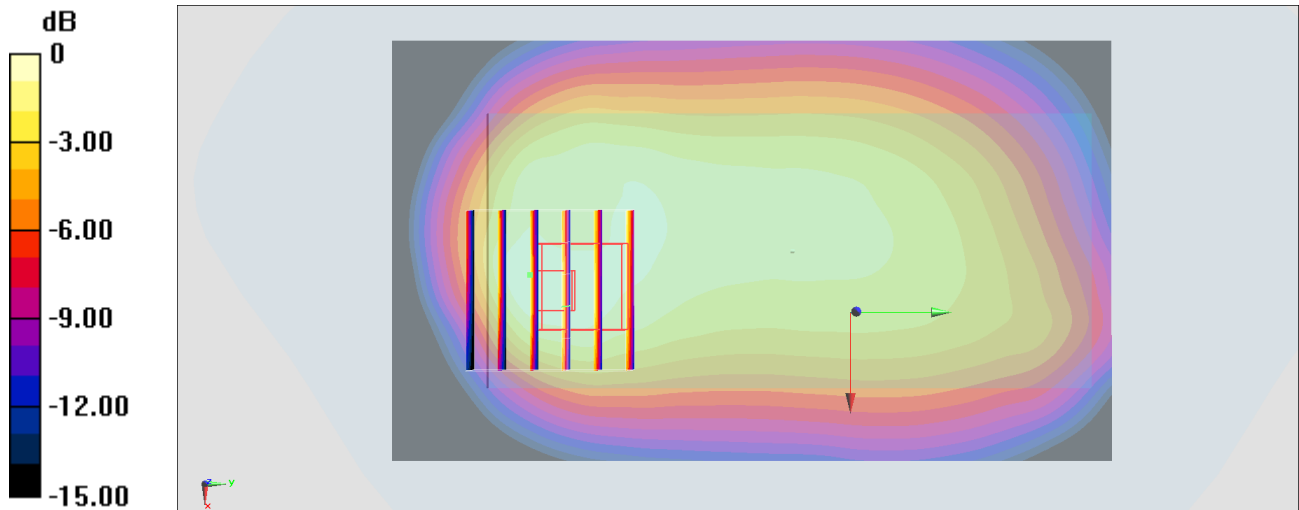

0 dB = 0.206 W/kg = -6.86 dBW/kg

#31_LTE Band 30_10M_QPSK_1_0_Back_10mm_Ch27710

Communication System: LTE ; Frequency: 2310 MHz;Duty Cycle: 1:1

Medium: HSL_2300_191031 Medium parameters used: $f = 2310$ MHz; $\sigma = 1.587$ S/m; $\epsilon_r = 39.4$; $\rho = 1000$ kg/m³

Ambient Temperature : 23.5 °C ; Liquid Temperature : 22.5 °C

DASY5 Configuration:

- Probe: ES3DV3 - SN3184; ConvF(4.96, 4.96, 4.96) @ 2310 MHz; Calibrated: 2019/9/25
- Sensor-Surface: 3mm (Mechanical Surface Detection)
- Electronics: DAE3 Sn495; Calibrated: 2019/5/21
- Phantom: SAM_Front; Type: QD000P40CD; Serial: 1719
- Measurement SW: DASY52, Version 52.10 (2);SEMCAD X Version 14.6.12 (7470)

Area Scan (91x101x1): Interpolated grid: dx=1.200 mm, dy=1.200 mm

Maximum value of SAR (interpolated) = 0.261 W/kg

Zoom Scan (7x7x7)/Cube 0: Measurement grid: dx=5mm, dy=5mm, dz=5mm

Reference Value = 12.77 V/m; Power Drift = 0.17 dB

Peak SAR (extrapolated) = 0.385 W/kg

SAR(1 g) = 0.221 W/kg; SAR(10 g) = 0.122 W/kg

Maximum value of SAR (measured) = 0.272 W/kg

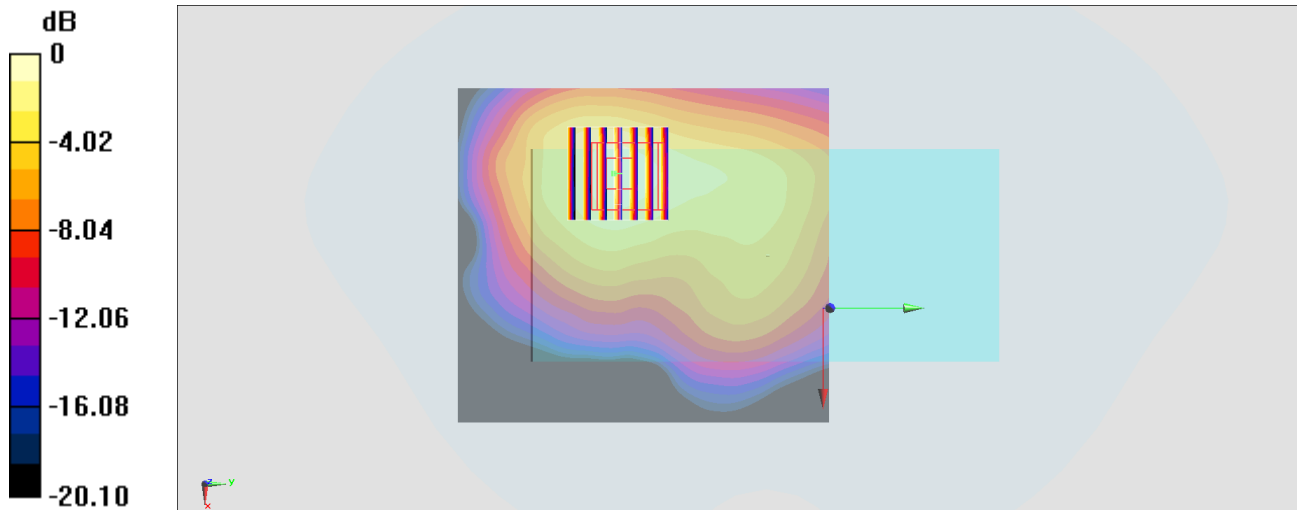

0 dB = 0.272 W/kg = -5.65 dBW/kg

#32_LTE Band 66_20M_QPSK_1_0_Bottom Side_10mm_Ch132572

Communication System: LTE; Frequency: 1770 MHz; Duty Cycle: 1:1

Medium: HSL_1750_191029 Medium parameters used: $f = 1770$ MHz; $\sigma = 1.383$ S/m; $\epsilon_r = 40.114$; $\rho = 1000$ kg/m³

Ambient Temperature : 23.6 °C ; Liquid Temperature : 22.6 °C

DASY5 Configuration:

- Probe: ES3DV3 - SN3184; ConvF(5.45, 5.45, 5.45) @ 1770 MHz; Calibrated: 2019/9/25
- Sensor-Surface: 3mm (Mechanical Surface Detection)
- Electronics: DAE3 Sn495; Calibrated: 2019/5/21
- Phantom: SAM LEFT; Type: QD000P40CD; Serial: TP:1718
- Measurement SW: DASY52, Version 52.10 (2); SEMCAD X Version 14.6.12 (7470)

Area Scan (41x61x1): Interpolated grid: dx=1.500 mm, dy=1.500 mm

Maximum value of SAR (interpolated) = 0.968 W/kg

Zoom Scan (5x5x7)/Cube 0: Measurement grid: dx=8mm, dy=8mm, dz=5mm

Reference Value = 26.96 V/m; Power Drift = -0.07 dB

Peak SAR (extrapolated) = 1.31 W/kg

SAR(1 g) = 0.886 W/kg; SAR(10 g) = 0.543 W/kg

Maximum value of SAR (measured) = 0.946 W/kg

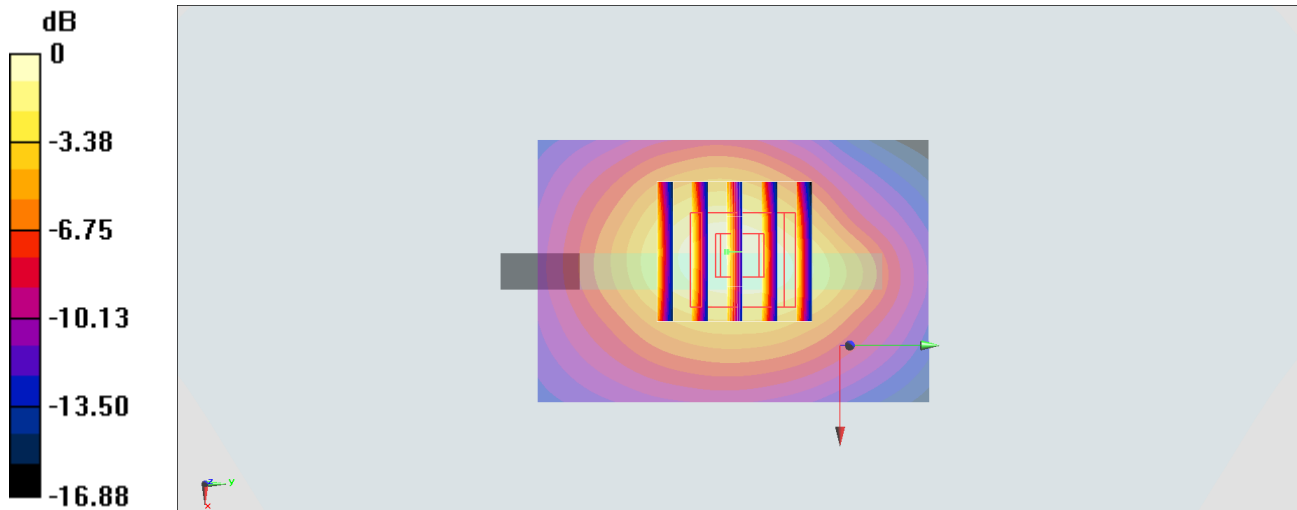

0 dB = 0.968 W/kg = -0.14 dBW/kg

#33_LTE Band 71_20M_QPSK_1_0_Back_10mm_Ch133322

Communication System: LTE; Frequency: 683 MHz; Duty Cycle: 1:1

Medium: HSL_750_191102 Medium parameters used: $f = 683$ MHz; $\sigma = 0.863$ S/m; $\epsilon_r = 43.824$; $\rho = 1000$ kg/m³

Ambient Temperature : 23.2 °C ; Liquid Temperature : 22.2 °C

DASY5 Configuration:

- Probe: EX3DV4 - SN7306; ConvF(9.97, 9.97, 9.97) @ 683 MHz; Calibrated: 2019/7/22
- Sensor-Surface: 1.4mm (Mechanical Surface Detection)
- Electronics: DAE4 Sn854; Calibrated: 2019/5/21
- Phantom: SAM_Left; Type: QD000P40CD; Serial: TP:1815
- Measurement SW: DASY52, Version 52.10 (2); SEMCAD X Version 14.6.12 (7470)

Area Scan (71x121x1): Interpolated grid: dx=1.500 mm, dy=1.500 mm

Maximum value of SAR (interpolated) = 0.202 W/kg

Zoom Scan (7x9x7)/Cube 0: Measurement grid: dx=8mm, dy=8mm, dz=5mm

Reference Value = 14.28 V/m; Power Drift = -0.17 dB

Peak SAR (extrapolated) = 0.283 W/kg

SAR(1 g) = 0.125 W/kg; SAR(10 g) = 0.083 W/kg

Maximum value of SAR (measured) = 0.206 W/kg

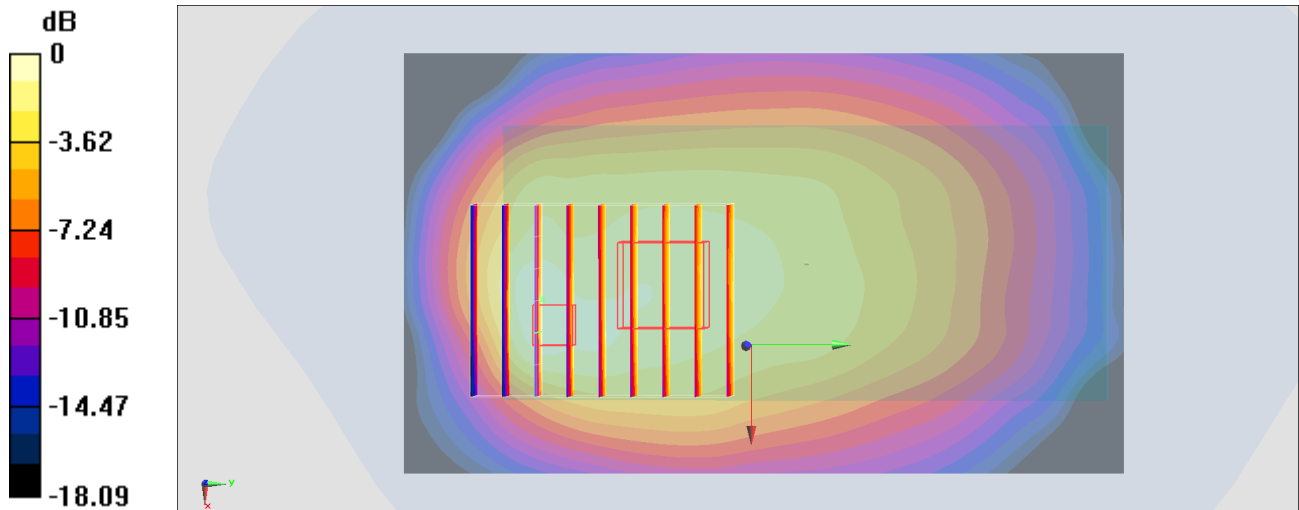

0 dB = 0.206 W/kg = -6.86 dBW/kg

#34_LTE Band 38_20M_QPSK_1_0_Back_10mm_Ch38000

Communication System: LTE; Frequency: 2595 MHz; Duty Cycle: 1:1.59

Medium: HSL_2600_191106 Medium parameters used : $f = 2595$ MHz; $\sigma = 1.917$ S/m; $\epsilon_r = 37.924$; $\rho = 1000$ kg/m³

Ambient Temperature : 23.4 °C ; Liquid Temperature : 22.4 °C

DASY5 Configuration:

- Probe: EX3DV4 - SN3931; ConvF(7.43, 7.43, 7.43) @ 2595 MHz; Calibrated: 2019/9/26
- Sensor-Surface: 1.4mm (Mechanical Surface Detection)
- Electronics: DAE4 Sn778; Calibrated: 2019/5/21
- Phantom: SAM_Left; Type: QD000P40CD; Serial: TP:1801
- Measurement SW: DASY52, Version 52.10 (2); SEMCAD X Version 14.6.12 (7450)

Area Scan (91x101x1): Interpolated grid: dx=1.200 mm, dy=1.200 mm

Maximum value of SAR (interpolated) = 1.29 W/kg

Zoom Scan (7x7x7)/Cube 0: Measurement grid: dx=5mm, dy=5mm, dz=5mm

Reference Value = 23.44 V/m; Power Drift = 0.09 dB

Peak SAR (extrapolated) = 1.49 W/kg

SAR(1 g) = 0.736 W/kg; SAR(10 g) = 0.369 W/kg

Maximum value of SAR (measured) = 1.19 W/kg

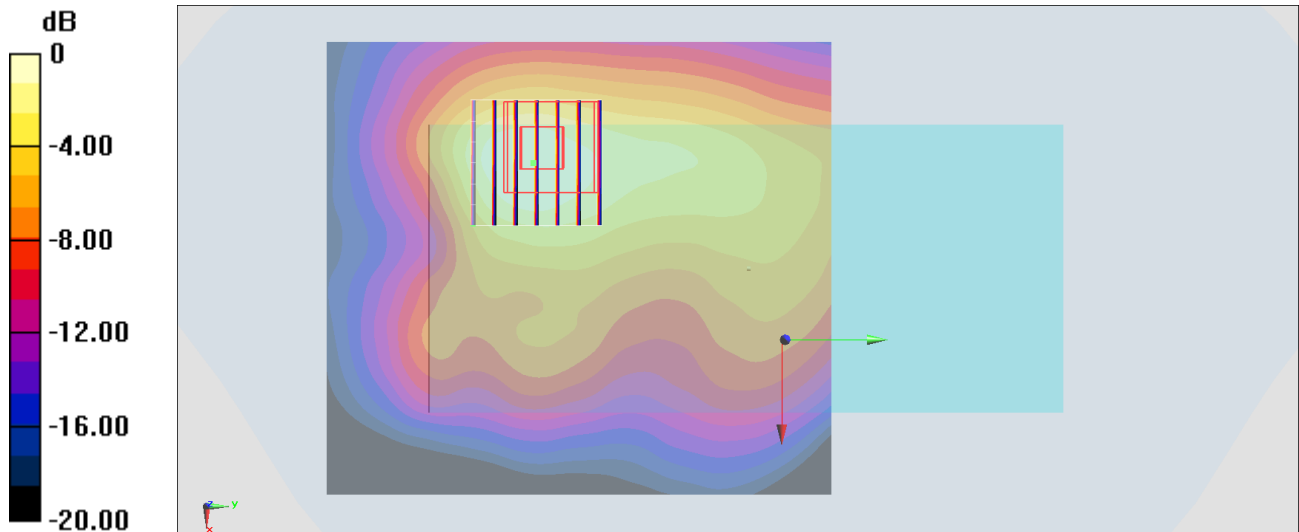

0 dB = 1.19 W/kg = 0.76 dBW/kg

#35_LTE Band 41_20M_QPSK_1_99_Right Side_10mm_Ch41490

Communication System: LTE; Frequency: 2680 MHz; Duty Cycle: 1:1.59

Medium: HSL_2600_191107 Medium parameters used: $f = 2680$ MHz; $\sigma = 2.078$ S/m; $\epsilon_r = 37.945$; $\rho = 1000$ kg/m³

Ambient Temperature : 23.4 °C ; Liquid Temperature : 22.4 °C

DASY5 Configuration:

- Probe: EX3DV4 - SN3931; ConvF(7.43, 7.43, 7.43) @ 2680 MHz; Calibrated: 2019/9/26
- Sensor-Surface: 1.4mm (Mechanical Surface Detection)
- Electronics: DAE4 Sn778; Calibrated: 2019/5/21
- Phantom: SAM_Left; Type: QD000P40CD; Serial: TP:1801
- Measurement SW: DASY52, Version 52.10 (2); SEMCAD X Version 14.6.12 (7450)

Area Scan (41x151x1): Interpolated grid: dx=1.200 mm, dy=1.200 mm

Maximum value of SAR (interpolated) = 1.11 W/kg

Zoom Scan (7x7x7)/Cube 0: Measurement grid: dx=5mm, dy=5mm, dz=5mm

Reference Value = 23.66 V/m; Power Drift = -0.00 dB

Peak SAR (extrapolated) = 1.44 W/kg

SAR(1 g) = 0.696 W/kg; SAR(10 g) = 0.345 W/kg

Maximum value of SAR (measured) = 1.15 W/kg

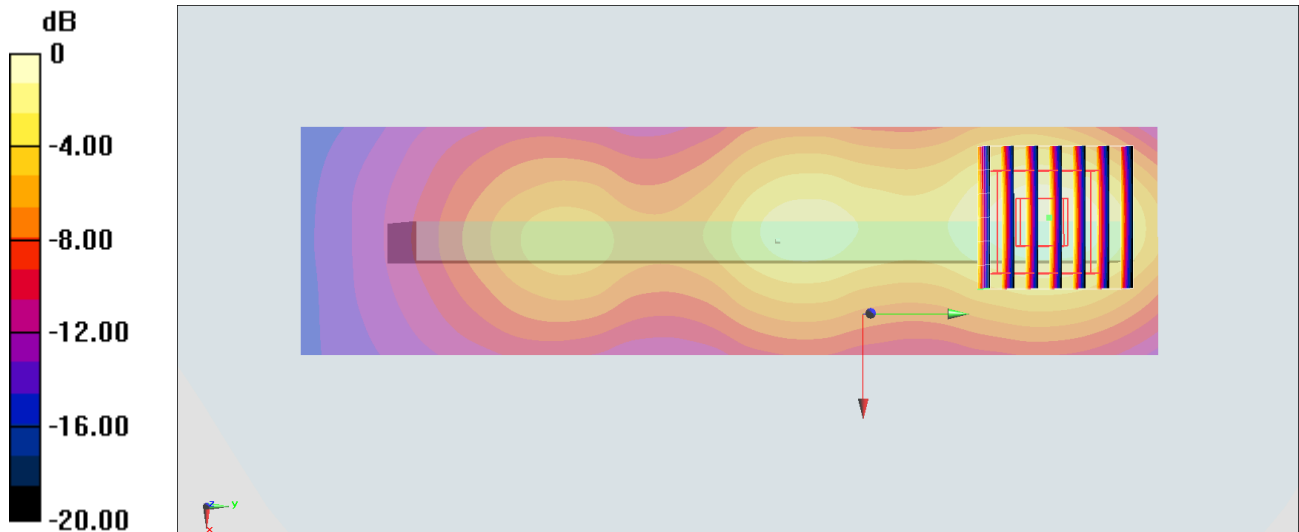

0 dB = 1.15 W/kg = 0.61 dBW/kg

#36_WLAN2.4GHz_802.11b 1Mbps_Back_10mm_Ch1

Communication System: 802.11b ; Frequency: 2412 MHz; Duty Cycle: 1:1.009

Medium: HSL_2450_191101 Medium parameters used: $f = 2412$ MHz; $\sigma = 1.769$ S/m; $\epsilon_r = 39.2$; $\rho = 1000$ kg/m³

Ambient Temperature : 23.4 °C ; Liquid Temperature : 22.4 °C

DASY5 Configuration:

- Probe: EX3DV4 - SN3925; ConvF(7.6, 7.6, 7.6) @ 2412 MHz; Calibrated: 2019/9/20
- Sensor-Surface: 1.4mm (Mechanical Surface Detection)
- Electronics: DAE4 Sn1399; Calibrated: 2018/11/16
- Phantom: SAM_Left; Type: QD000P40CD; Serial: TP:1801
- Measurement SW: DASY52, Version 52.10 (2); SEMCAD X Version 14.6.12 (7470)

Area Scan (81x91x1): Interpolated grid: dx=1.200 mm, dy=1.200 mm

Maximum value of SAR (interpolated) = 0.954 W/kg

Zoom Scan (7x7x7)/Cube 0: Measurement grid: dx=5mm, dy=5mm, dz=5mm

Reference Value = 23.22 V/m; Power Drift = -0.11 dB

Peak SAR (extrapolated) = 1.13 W/kg

SAR(1 g) = 0.568 W/kg; SAR(10 g) = 0.282 W/kg

Maximum value of SAR (measured) = 0.921 W/kg

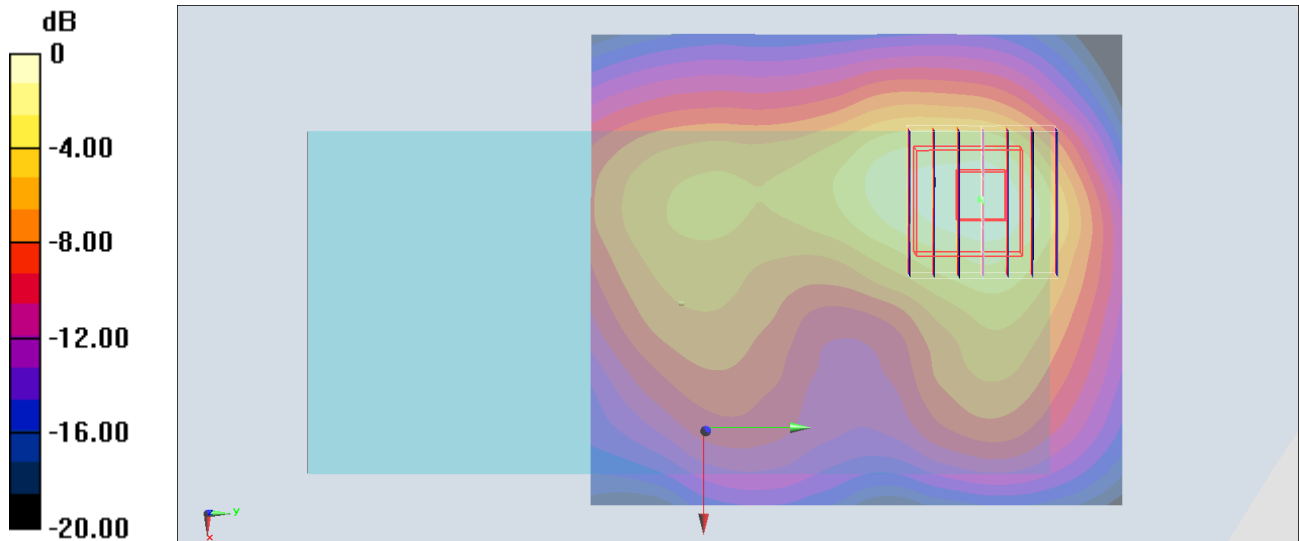

0 dB = 0.954 W/kg = -0.20 dBW/kg

#37_WLAN5GHz_802.11n-HT40 MCS0_Back_10mm_Ch46

Communication System: 802.11n ; Frequency: 5230 MHz;Duty Cycle: 1:1.042

Medium: HSL_5G_191029 Medium parameters used : $f = 5230$ MHz; $\sigma = 4.535$ S/m; $\epsilon_r = 36.03$; $\rho = 1000$ kg/m³

Ambient Temperature : 23.5 °C ; Liquid Temperature : 22.5 °C

DASY5 Configuration:

- Probe: EX3DV4 - SN3925; ConvF(5.49, 5.49, 5.49) @ 5230 MHz; Calibrated: 2019/9/20
- Sensor-Surface: 1.4mm (Mechanical Surface Detection)
- Electronics: DAE4 Sn1399; Calibrated: 2018/11/16
- Phantom: SAM_Right; Type: QD000P40CD; Serial: 1884
- Measurement SW: DASY52, Version 52.10 (2);SEMCAD X Version 14.6.12 (7470)

Area Scan (91x91x1): Interpolated grid: dx=1.000 mm, dy=1.000 mm

Maximum value of SAR (interpolated) = 1.07 W/kg

Zoom Scan (7x7x7)/Cube 0: Measurement grid: dx=4mm, dy=4mm, dz=1.4mm

Reference Value = 16.19 V/m; Power Drift = -0.01 dB

Peak SAR (extrapolated) = 1.68 W/kg

SAR(1 g) = 0.505 W/kg; SAR(10 g) = 0.179 W/kg

Maximum value of SAR (measured) = 1.07 W/kg

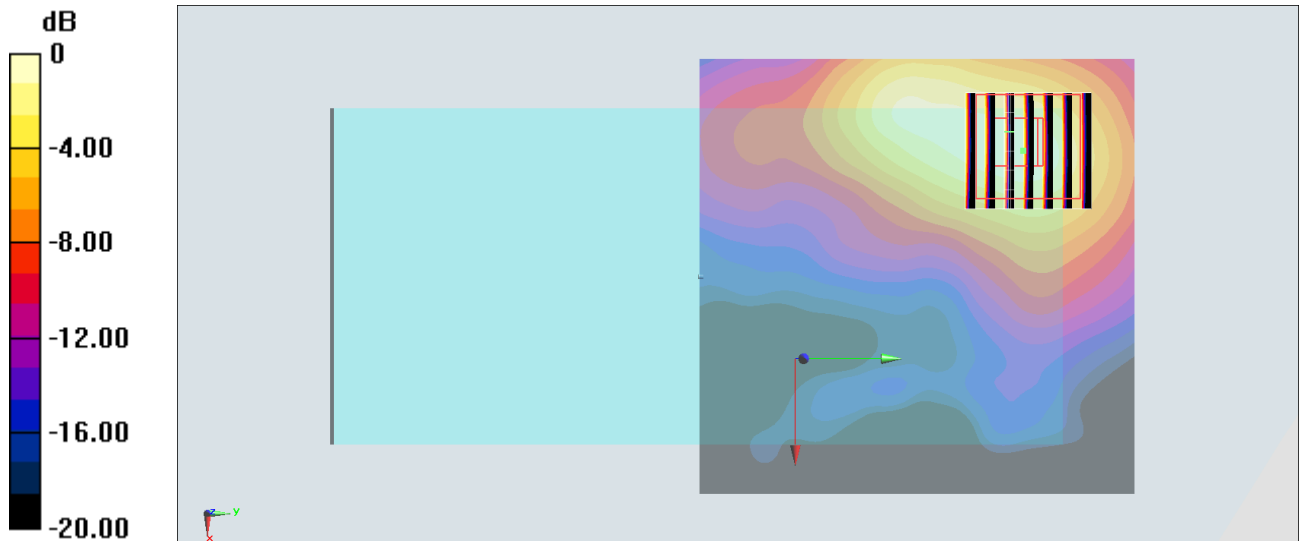

0 dB = 1.07 W/kg = 0.29 dBW/kg

#38_WLAN5GHz_802.11ac-VHT80 MCS0_Back_10mm_Ch155

Communication System: 802.11ac ; Frequency: 5775 MHz; Duty Cycle: 1:1.079

Medium: HSL_5G_191031 Medium parameters used: $f = 5775$ MHz; $\sigma = 5.078$ S/m; $\epsilon_r = 35.32$; $\rho = 1000$ kg/m³

Ambient Temperature : 23.5 °C ; Liquid Temperature : 22.5 °C

DASY5 Configuration:

- Probe: EX3DV4 - SN3925; ConvF(5.22, 5.22, 5.22) @ 5775 MHz; Calibrated: 2019/9/20
- Sensor-Surface: 1.4mm (Mechanical Surface Detection)
- Electronics: DAE4 Sn1399; Calibrated: 2018/11/16
- Phantom: SAM_Right; Type: QD000P40CD; Serial: 1884
- Measurement SW: DASY52, Version 52.10 (2); SEMCAD X Version 14.6.12 (7470)

Area Scan (91x91x1): Interpolated grid: dx=1.000 mm, dy=1.000 mm

Maximum value of SAR (interpolated) = 1.31 W/kg

Zoom Scan (7x7x7)/Cube 0: Measurement grid: dx=4mm, dy=4mm, dz=1.4mm

Reference Value = 17.41 V/m; Power Drift = -0.02 dB

Peak SAR (extrapolated) = 2.01 W/kg

SAR(1 g) = 0.525 W/kg; SAR(10 g) = 0.191 W/kg

Maximum value of SAR (measured) = 1.19 W/kg

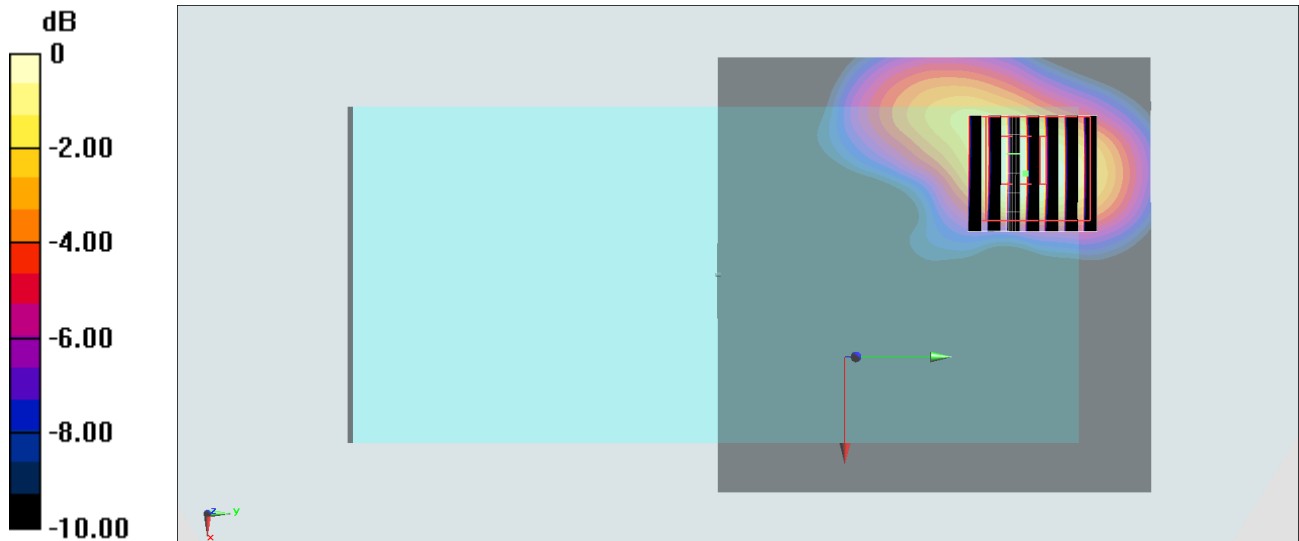

0 dB = 1.19 W/kg = 0.76 dBW/kg