

FCC Test Report

(PART 27)

Report No.: RF181001C08-10

FCC ID: A4RG020B

Model Name: G020B

Received Date: Oct. 01, 2018

Test Date: Oct. 25, 2018 ~ Nov. 07, 2018

Issued Date: Dec. 27, 2018

Applicant: Google LLC

Address: 1600 Amphitheatre Parkway, Mountain View, CA 94043, USA

Issued By: Bureau Veritas Consumer Products Services (H.K.) Ltd., Taoyuan Branch

Lab Address: No. 47-2, 14th Ling, Chia Pau Vil., Lin Kou Dist., New Taipei City, Taiwan
(R.O.C)

Test Location (1): No. 19, Hwa Ya 2nd Rd, Wen Hwa Vil, Kwei Shan Dist., Taoyuan City
33383, Taiwan (R.O.C)

**FCC Registration /
Designation Number:** 788550 / TW0003



This report is for your exclusive use. Any copying or replication of this report to or for any other person or entity, or use of our name or trademark, is permitted only with our prior written permission. This report sets forth our findings solely with respect to the test samples identified herein. The results set forth in this report are not indicative or representative of the quality or characteristics of the lot from which a test sample was taken or any similar or identical product unless specifically and expressly noted. Our report includes all of the tests requested by you and the results thereof based upon the information that you provided to us. You have 60 days from date of issuance of this report to notify us of any material error or omission caused by our negligence, provided, however, that such notice shall be in writing and shall specifically address the issue you wish to raise. A failure to raise such issue within the prescribed time shall constitute your unqualified acceptance of the completeness of this report, the tests conducted and the correctness of the report contents. Unless specific mention, the uncertainty of measurement has been explicitly taken into account to declare the compliance or non-compliance to the specification. The report must not be used by the client to claim product certification, approval, or endorsement by TAF or any government agencies

Table of Contents

Release Control Record	4
1 Certificate of Conformity	5
2 Summary of Test Results	6
2.1 Measurement Uncertainty	6
2.2 Test Site and Instruments	7
3 General Information	8
3.1 General Description of EUT	8
3.2 Configuration of System under Test	10
3.2.1 Description of Support Units	10
3.3 Test Mode Applicability and Tested Channel Detail	11
3.4 EUT Operating Conditions	15
3.5 General Description of Applied Standards	15
4 Test Types and Results	16
4.1 Output Power Measurement	16
4.1.1 Limits of Output Power Measurement	16
4.1.2 Test Procedures	16
4.1.3 Test Setup	17
4.1.4 Test Results	18
4.2 Modulation Characteristics Measurement	33
4.2.1 Limits of Modulation Characteristics	33
4.2.2 Test Setup	33
4.2.3 Test Procedure	33
4.2.4 Test Results	34
4.3 Frequency Stability Measurement	37
4.3.1 Limits of Frequency Stability Measurement	37
4.3.2 Test Procedure	37
4.3.3 Test Setup	37
4.3.4 Test Results	38
4.4 Occupied Bandwidth Measurement	50
4.4.1 Limits of Occupied Bandwidth Measurement	50
4.4.2 Test Procedure	50
4.4.3 Test Setup	50
4.4.4 Test Results	51
4.5 Out-of-Band Emissions Measurement	63
4.5.1 Limits of Out-of-Band Emissions Measurement	63
4.5.2 Test Setup	63
4.5.3 Test Procedures	63
4.5.4 Test Results	64
4.6 Peak to Average Ratio	100
4.6.1 Limits of Peak to Average Ratio Measurement	100
4.6.2 Test Setup	100
4.6.3 Test Procedures	100
4.6.4 Test Results	101
4.7 Conducted Spurious Emissions	107
4.7.1 Limits of Conducted Spurious Emissions Measurement	107
4.7.2 Test Setup	107
4.7.3 Test Procedure	107
4.7.4 Test Results	108
4.8 Radiated Emission Measurement	144
4.8.1 Limits of Radiated Emission Measurement	144
4.8.2 Test Procedure	144
4.8.3 Deviation from Test Standard	144
4.8.4 Test Setup	145

4.8.5 Test Results	146
5 Pictures of Test Arrangements.....	182
Appendix – Information on the Testing Laboratories	183

Release Control Record

Issue No.	Description	Date Issued
RF181001C08-10	Original Release	Dec. 27, 2018

1 Certificate of Conformity

Product: Smartphone

Model Name: G020B

Sample Status: Identical Prototype

Applicant: Google LLC

Test Date: Oct. 25, 2018 ~ Nov. 07, 2018

Standards: FCC Part 27, Subpart C, M

The above equipment has been tested by **Bureau Veritas Consumer Products Services (H.K.) Ltd., Taoyuan Branch**, and found compliance with the requirement of the above standards. The test record, data evaluation & Equipment Under Test (EUT) configurations represented herein are true and accurate accounts of the measurements of the sample's RF characteristics under the conditions specified in this report.

Prepared by :  _____, **Date:** Dec. 27, 2018
Ivonne Wu / Supervisor

Approved by :  _____, **Date:** Dec. 27, 2018
Dylan Chiou / Project Engineer

2 Summary of Test Results

Applied Standard: FCC Part 27 & Part 2			
FCC Clause	Test Item	Result	Remarks
2.1046 27.50(h)(2)	Equivalent Isotropic Radiated Power	Pass	Meet the requirement of limit.
2.1047	Modulation Characteristics	Pass	Meet the requirement.
2.1055 27.54	Frequency Stability	Pass	Meet the requirement of limit.
2.1049 27.53(m)(6)	Occupied Bandwidth	Pass	Meet the requirement of limit.
--	Peak to Average Ratio	Pass	Meet the requirement of limit.
2.1051 27.53(m)(4)(6)	Out-of-Band Emissions Measurements	Pass	Meet the requirement of limit.
2.1051 27.53(m)(4)(6)	Conducted Spurious Emissions	Pass	Meet the requirement of limit.
2.1053 27.53(m)(4)(6)	Radiated Spurious Emissions	Pass	Meet the requirement of limit. Minimum passing margin is -19.22 dB at 30.97 MHz.

2.1 Measurement Uncertainty

Where relevant, the following measurement uncertainty levels have been estimated for tests performed on the EUT as specified in CISPR 16-4-2:

Measurement	Frequency	Expanded Uncertainty (k=2) (\pm)
Radiated Emissions up to 1 GHz	30 MHz ~ 200 MHz	2.93 dB
	200 MHz ~ 1000 MHz	2.95 dB
Radiated Emissions above 1 GHz	1 GHz ~ 18 GHz	2.26 dB
	18 GHz ~ 40 GHz	1.94 dB

2.2 Test Site and Instruments

Description & Manufacturer	Model No.	Serial No.	Date of Calibration	Due Date of Calibration
Test Receiver Agilent	N9038A	MY51210203	Mar. 16, 2018	Mar. 15, 2019
Spectrum Analyzer Keysight	N9010A	MY56070348	Sep. 06, 2018	Sep. 05, 2019
Spectrum Analyzer ROHDE & SCHWARZ	FSU43	101261	Jan. 11, 2018	Jan. 10, 2019
HORN Antenna SCHWARZBECK	BBHA 9120D	9120D-969	Dec. 12, 2017	Dec. 11, 2018
BILOG Antenna SCHWARZBECK	VULB 9168	9168-472	Dec. 06, 2017	Dec. 05, 2018
Fixed Attenuator Mini-Circuits	MDCS18N-10	MDCS18N-10-01	Apr. 16, 2018	Apr. 15, 2019
MXG Vector signal generator Agilent	N5182B	MY53052658	May 24, 2018	May 23, 2019
Preamplifier EMCI	EMC 184045	980116	Oct. 12, 2018	Oct. 11, 2019
Preamplifier EMCI	EMC 012645	980115	Oct. 12, 2018	Oct. 11, 2019
Preamplifier EMCI	EMC 330H	980112	Oct. 12, 2018	Oct. 11, 2019
RF Coaxial Cable HUBER+SUHNNER	EMC104-SM-SM-800 0&3000	140811+170717	Oct. 12, 2018	Oct. 11, 2019
RF Coaxial Cable HUBER+SUHNNER	SUCOFLEX 104	EMC104-SM-SM-1 000(140807)	Oct. 12, 2018	Oct. 11, 2019
RF Coaxial Cable WOKEN	8D-FB	Cable-Ch10-01	Oct. 12, 2018	Oct. 11, 2019
Boresight Antenna Fixture	FBA-01	FBA-SIP01	NA	NA
Software BV ADT	E3 6.120103	NA	NA	NA
Antenna Tower MF	MFA-440H	NA	NA	NA
Turn Table MF	MFT-201SS	NA	NA	NA
Antenna Tower & Turn Table Controller MF	MF-7802	NA	NA	NA
Radio Communication Analyzer Anritsu	MT8820C	6201300640	Aug. 16, 2017	Aug. 15, 2019
Temperature & Humidity Chamber	GTH-120-40-CP-AR	MAA1306-019	Sep. 05, 2018	Sep. 04, 2019
DC Power Supply Topward	33010D	807748	NA	NA

- Note: 1. The calibration interval of the above test instruments is 12 / 24 months and the calibrations are traceable to NML/ROC and NIST/USA.
2. The test was performed in HwaYa Chamber 10.
3. The horn antenna and preamplifier (model: EMC 184045) are used only for the measurement of emission frequency above 1 GHz if tested.
4. The IC Site Registration No. is 7450F-10.

3 General Information

3.1 General Description of EUT

Product	Smartphone	
Model Name	G020B	
Status of EUT	Identical Prototype	
Power Supply Rating	3.85 Vdc (Li-ion battery) 5.0 Vdc or 9 Vdc (adapter) 5.0 Vdc (host equipment)	
Modulation Type	QPSK, 16QAM, 64QAM	
Frequency Range	LTE Band 7 (Channel Bandwidth: 5 MHz)	2502.5 ~ 2567.5 MHz
	LTE Band 7 (Channel Bandwidth: 10 MHz)	2505 ~ 2565 MHz
	LTE Band 7 (Channel Bandwidth: 15 MHz)	2507.5 ~ 2562.5 MHz
	LTE Band 7 (Channel Bandwidth: 20 MHz)	2510 ~ 2560 MHz
	LTE Band 38 (Channel Bandwidth: 5 MHz)	2572.5 ~ 2617.5 MHz
	LTE Band 38 (Channel Bandwidth: 10 MHz)	2575.0 ~ 2615.0 MHz
	LTE Band 38 (Channel Bandwidth: 15 MHz)	2577.5 ~ 2612.5 MHz
	LTE Band 38 (Channel Bandwidth: 20 MHz)	2580.0 ~ 2610.0 MHz
	LTE Band 41 (Channel Bandwidth: 5 MHz)	2498.5 ~ 2687.5 MHz
	LTE Band 41 (Channel Bandwidth: 10 MHz)	2501.0 ~ 2685.0 MHz
	LTE Band 41 (Channel Bandwidth: 15 MHz)	2503.5 ~ 2682.5 MHz
	LTE Band 41 (Channel Bandwidth: 20 MHz)	2506.0 ~ 2680.0 MHz
Max. EIRP Power	LTE Band 7 (Channel Bandwidth: 5 MHz)	144.21 mW
	LTE Band 7 (Channel Bandwidth: 10 MHz)	152.41 mW
	LTE Band 7 (Channel Bandwidth: 15 MHz)	160.69 mW
	LTE Band 7 (Channel Bandwidth: 20 MHz)	170.22 mW
	LTE Band 38 (Channel Bandwidth: 5 MHz)	142.56 mW
	LTE Band 38 (Channel Bandwidth: 10 MHz)	150.66 mW
	LTE Band 38 (Channel Bandwidth: 15 MHz)	167.49 mW
	LTE Band 38 (Channel Bandwidth: 20 MHz)	177.01 mW
	LTE Band 41 (Channel Bandwidth: 5 MHz)	167.49 mW
	LTE Band 41 (Channel Bandwidth: 10 MHz)	175.79 mW
	LTE Band 41 (Channel Bandwidth: 15 MHz)	185.78 mW
	LTE Band 41 (Channel Bandwidth: 20 MHz)	195.88 mW

Emission Designator	LTE Band 7 (Channel Bandwidth: 5 MHz)	4M50W7D
	LTE Band 7 (Channel Bandwidth: 10 MHz)	8M97W7D
	LTE Band 7 (Channel Bandwidth: 15 MHz)	13M5G7D
	LTE Band 7 (Channel Bandwidth: 20 MHz)	17M9W7D
	LTE Band 38 (Channel Bandwidth: 5 MHz)	4M50W7D
	LTE Band 38 (Channel Bandwidth: 10 MHz)	8M97W7D
	LTE Band 38 (Channel Bandwidth: 15 MHz)	13M4G7D
	LTE Band 38 (Channel Bandwidth: 20 MHz)	17M9W7D
	LTE Band 41 (Channel Bandwidth: 5 MHz)	4M50W7D
	LTE Band 41 (Channel Bandwidth: 10 MHz)	8M97W7D
	LTE Band 41 (Channel Bandwidth: 15 MHz)	13M4G7D
	LTE Band 41 (Channel Bandwidth: 20 MHz)	17M9W7D
Antenna Type	PIFA Antenna	
Antenna Gain	LTE 7	0.6 dBi gain
	LTE 38	0.6 dBi gain
	LTE 41	-2 dBi gain
Accessory Device	Refer to Note as below	
Data Cable Supplied	Refer to Note as below	

Note:

- There're 2 configurations for the EUT listed as below.
 Main Sample: EUT + Battery 1
 2nd Sample: EUT + Battery 2
 ✧ After pre-tested with the EUT, only the worst configuration (main sample) was chosen for the final test.
- The EUT's accessories list refers to Ext. Pho.
- The above EUT information is declared by manufacturer and for more detailed features description, please refers to the manufacturer's specifications or user's manual.

3.2 Configuration of System under Test

<Radiated Emission Test>

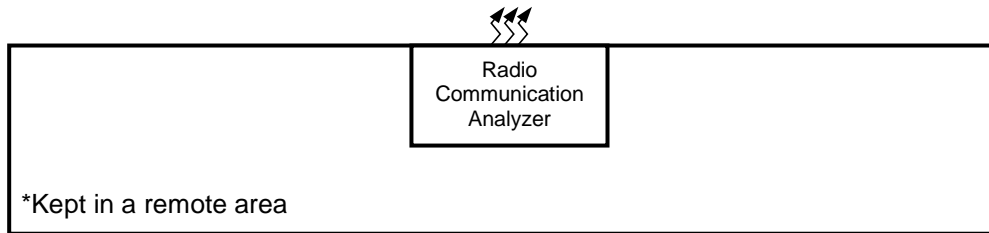
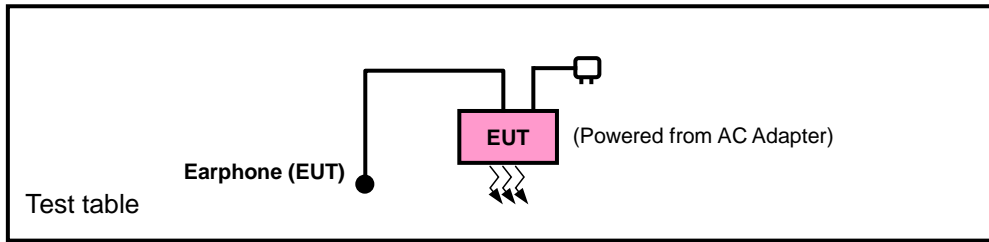

<E.I.R.P. Test>

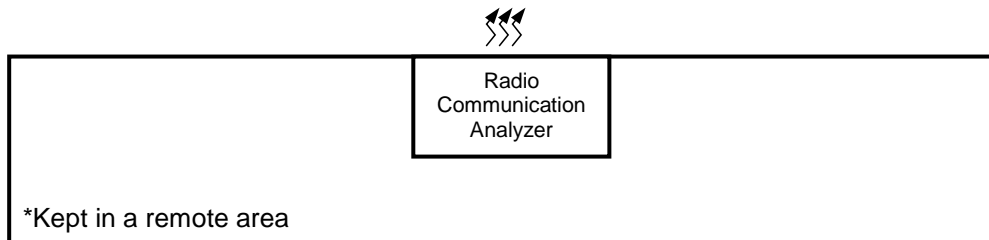
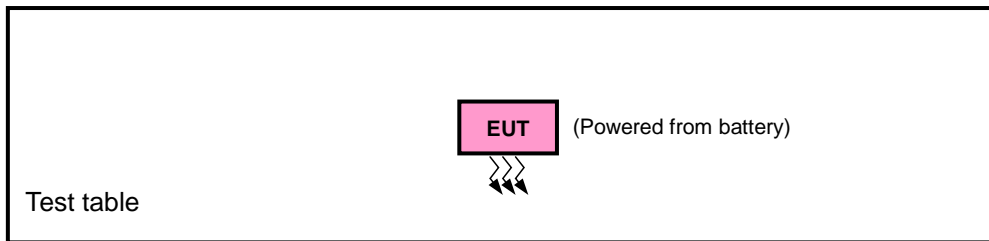

3.2.1 Description of Support Units

The EUT has been tested as an independent unit together with other necessary accessories or support units.

3.3 Test Mode Applicability and Tested Channel Detail

Pre-Scan has been conducted to determine the worst-case mode from all possible combinations between available modulations, data rates, XYZ axis, and antenna ports.

The worst case was found when positioned as the table below. Following channel(s) was (were) selected for the final test as listed below:

Band	EIRP	Radiated Emission
LTE Band 7	X-plane	Y-axis
LTE Band 38	X-plane	X-axis
LTE Band 41	X-plane	X-axis

LTE Band 7

EUT Configure Mode	Test Item	Available Channel	Tested Channel	Channel Bandwidth	Modulation	Mode
-	EIRP	20775 to 21425	20775, 21100, 21425	5 MHz	QPSK, 16QAM, 64QAM	1 RB / 0 RB Offset
		20800 to 21400	20800, 21100, 21400	10 MHz	QPSK, 16QAM, 64QAM	1 RB / 0 RB Offset
		20825 to 21375	20825, 21100, 21375	15 MHz	QPSK, 16QAM, 64QAM	1 RB / 0 RB Offset
		20850 to 21350	20850, 21100 21350	20 MHz	QPSK, 16QAM, 64QAM	1 RB / 0 RB Offset
-	Modulation Characteristics	20850 to 21350	20850	20 MHz	QPSK, 16QAM, 64QAM	100 RB / 0 RB Offset
-	Frequency Stability	20775 to 21425	20775, 21425	5 MHz	QPSK	1 RB / 0 RB Offset
		20800 to 21400	20800, 21400	10 MHz	QPSK	1 RB / 0 RB Offset
		20825 to 21375	20825, 21375	15 MHz	QPSK	1 RB / 0 RB Offset
		20850 to 21350	20850, 21350	20 MHz	QPSK	1 RB / 0 RB Offset
-	Occupied Bandwidth	20775 to 21425	20775, 21100, 21425	5 MHz	QPSK, 16QAM, 64QAM	25 RB / 0 RB Offset
		20800 to 21400	20800, 21100, 21400	10 MHz	QPSK, 16QAM, 64QAM	50 RB / 0 RB Offset
		20825 to 21375	20825, 21100, 21375	15 MHz	QPSK, 16QAM, 64QAM	75 RB / 0 RB Offset
		20850 to 21350	20850, 21100 21350	20 MHz	QPSK, 16QAM, 64QAM	100 RB / 0 RB Offset
-	Peak to Average Ratio	20775 to 21425	20775, 21100, 21425	5 MHz	QPSK, 16QAM, 64QAM	1 RB / 0 RB Offset
		20800 to 21400	20800, 21100, 21400	10 MHz	QPSK, 16QAM, 64QAM	1 RB / 0 RB Offset
		20825 to 21375	20825, 21100, 21375	15 MHz	QPSK, 16QAM, 64QAM	1 RB / 0 RB Offset
		20850 to 21350	20850, 21100 21350	20 MHz	QPSK, 16QAM, 64QAM	1 RB / 0 RB Offset
-	Out-of-Band Emissions	20775 to 21425	20775, 21425	5 MHz	QPSK, 16QAM, 64QAM	25 RB / 0 RB Offset
		20800 to 21400	20800, 21400	10 MHz	QPSK, 16QAM, 64QAM	50 RB / 0 RB Offset
		20825 to 21375	20825, 21375	15 MHz	QPSK, 16QAM, 64QAM	75 RB / 0 RB Offset
		20850 to 21350	20850, 21350	20 MHz	QPSK, 16QAM, 64QAM	100 RB / 0 RB Offset

EUT Configure Mode	Test Item	Available Channel	Tested Channel	Channel Bandwidth	Modulation	Mode
-	Conducted Emission	20775 to 21425	20775, 21100, 21425	5 MHz	QPSK	1 RB / 0 RB Offset
		20800 to 21400	20800, 21100, 21400	10 MHz	QPSK	1 RB / 0 RB Offset
		20825 to 21375	20825, 21100, 21375	15 MHz	QPSK	1 RB / 0 RB Offset
		20850 to 21350	20850, 21100 21350	20 MHz	QPSK	1 RB / 0 RB Offset
-	Radiated Emission	20775 to 21425	20775, 21100, 21425	5 MHz	QPSK	1 RB / 0 RB Offset
		20850 to 21350	20850, 21100 21350	20 MHz	QPSK	1 RB / 0 RB Offset

Note: This device was tested under all bandwidths, RB configurations and modulations. The worst case was found in QPSK modulation.

LTE Band 38

EUT Configure Mode	Test Item	Available Channel	Tested Channel	Channel Bandwidth	Modulation	Mode
-	EIRP	37775 to 38225	37775, 38000, 38225	5 MHz	QPSK, 16QAM, 64QAM	1 RB / 0 RB Offset
		37800 to 38200	37800, 38000, 38200	10 MHz	QPSK, 16QAM, 64QAM	1 RB / 0 RB Offset
		37825 to 38175	37825, 38000, 38175	15 MHz	QPSK, 16QAM, 64QAM	1 RB / 0 RB Offset
		37850 to 38150	37850, 38000, 38150	20 MHz	QPSK, 16QAM, 64QAM	1 RB / 0 RB Offset
-	Modulation Characteristics	37850 to 38150	37850	20 MHz	QPSK, 16QAM, 64QAM	25 RB / 0 RB Offset
-	Frequency Stability	37775 to 38225	37775, 38225	5 MHz	QPSK	1 RB / 0 RB Offset
		37800 to 38200	37800, 38200	10 MHz	QPSK	1 RB / 0 RB Offset
		37825 to 38175	37825, 38175	15 MHz	QPSK	1 RB / 0 RB Offset
		37850 to 38150	37850, 38150	20 MHz	QPSK	1 RB / 0 RB Offset
-	Occupied Bandwidth	37775 to 38225	37775, 38000, 38225	5 MHz	QPSK, 16QAM, 64QAM	25 RB / 0 RB Offset
		37800 to 38200	37800, 38000, 38200	10 MHz	QPSK, 16QAM, 64QAM	50 RB / 0 RB Offset
		37825 to 38175	37825, 38000, 38175	15 MHz	QPSK, 16QAM, 64QAM	75 RB / 0 RB Offset
		37850 to 38150	37850, 38000, 38150	20 MHz	QPSK, 16QAM, 64QAM	100 RB / 0 RB Offset
-	Peak to Average Ratio	37775 to 38225	37775, 38000, 38225	5 MHz	QPSK, 16QAM, 64QAM	1 RB / 0 RB Offset
		37800 to 38200	37800, 38000, 38200	10 MHz	QPSK, 16QAM, 64QAM	1 RB / 0 RB Offset
		37825 to 38175	37825, 38000, 38175	15 MHz	QPSK, 16QAM, 64QAM	1 RB / 0 RB Offset
		37850 to 38150	37850, 38000, 38150	20 MHz	QPSK, 16QAM, 64QAM	1 RB / 0 RB Offset
-	Out-of-Band Emissions	37775 to 38225	37775, 38225	5 MHz	QPSK, 16QAM, 64QAM	25 RB / 0 RB Offset
		37800 to 38200	37800, 38200	10 MHz	QPSK, 16QAM, 64QAM	50 RB / 0 RB Offset
		37825 to 38175	37825, 38175	15 MHz	QPSK, 16QAM, 64QAM	75 RB / 0 RB Offset
		37850 to 38150	37850, 38150	20 MHz	QPSK, 16QAM, 64QAM	100 RB / 0 RB Offset
-	Conducted Emission	37775 to 38225	37775, 38000, 38225	5 MHz	QPSK	1 RB / 0 RB Offset
		37800 to 38200	37800, 38000, 38200	10 MHz	QPSK	1 RB / 0 RB Offset
		37825 to 38175	37825, 38000, 38175	15 MHz	QPSK	1 RB / 0 RB Offset
		37850 to 38150	37850, 38000, 38150	20 MHz	QPSK	1 RB / 0 RB Offset
-	Radiated Emission	37775 to 38225	37775, 38000, 38225	5 MHz	QPSK	1 RB / 0 RB Offset
		37850 to 38150	37850, 38000, 38150	20 MHz	QPSK	1 RB / 0 RB Offset

Note: This device was tested under all bandwidths, RB configurations and modulations. The worst case was found in QPSK modulation.

LTE Band 41

EUT Configure Mode	Test Item	Available Channel	Tested Channel	Channel Bandwidth	Modulation	Mode
-	EIRP	39675 to 41565	39675, 40620, 41565	5 MHz	QPSK, 16QAM, 64QAM	1 RB / 0 RB Offset
		39700 to 41540	39700, 40620, 41540	10 MHz	QPSK, 16QAM, 64QAM	1 RB / 0 RB Offset
		39725 to 41515	39725, 40620, 41515	15 MHz	QPSK, 16QAM, 64QAM	1 RB / 0 RB Offset
		39750 to 41490	39750, 40620, 41490	20 MHz	QPSK, 16QAM, 64QAM	1 RB / 0 RB Offset
-	Modulation Characteristics	39750 to 41490	39750	20 MHz	QPSK, 16QAM, 64QAM	25 RB / 0 RB Offset
-	Frequency Stability	39675 to 41565	39675, 41565	5 MHz	QPSK	1 RB / 0 RB Offset
		39700 to 41540	39700, 41540	10 MHz	QPSK	1 RB / 0 RB Offset
		39725 to 41515	39725, 41515	15 MHz	QPSK	1 RB / 0 RB Offset
		39750 to 41490	39750, 41490	20 MHz	QPSK	1 RB / 0 RB Offset
-	Occupied Bandwidth	39675 to 41565	39675, 40620, 41565	5 MHz	QPSK, 16QAM, 64QAM	25 RB / 0 RB Offset
		39700 to 41540	39700, 40620, 41540	10 MHz	QPSK, 16QAM, 64QAM	50 RB / 0 RB Offset
		39725 to 41515	39725, 40620, 41515	15 MHz	QPSK, 16QAM, 64QAM	75 RB / 0 RB Offset
		39750 to 41490	39750, 40620, 41490	20 MHz	QPSK, 16QAM, 64QAM	100 RB / 0 RB Offset
-	Peak to Average Ratio	39675 to 41565	39675, 40620, 41565	5 MHz	QPSK, 16QAM, 64QAM	1 RB / 0 RB Offset
		39700 to 41540	39700, 40620, 41540	10 MHz	QPSK, 16QAM, 64QAM	1 RB / 0 RB Offset
		39725 to 41515	39725, 40620, 41515	15 MHz	QPSK, 16QAM, 64QAM	1 RB / 0 RB Offset
		39750 to 41490	39750, 40620, 41490	20 MHz	QPSK, 16QAM, 64QAM	1 RB / 0 RB Offset
-	Out-of-Band Emissions	39675 to 41565	39675, 41565	5 MHz	QPSK, 16QAM, 64QAM	25 RB / 0 RB Offset
		39700 to 41540	39700, 41540	10 MHz	QPSK, 16QAM, 64QAM	50 RB / 0 RB Offset
		39725 to 41515	39725, 41515	15 MHz	QPSK, 16QAM, 64QAM	75 RB / 0 RB Offset
		39750 to 41490	39750, 41490	20 MHz	QPSK, 16QAM, 64QAM	100 RB / 0 RB Offset
-	Conducted Emission	39675 to 41565	39675, 40620, 41565	5 MHz	QPSK	1 RB / 0 RB Offset
		39700 to 41540	39700, 40620, 41540	10 MHz	QPSK	1 RB / 0 RB Offset
		39725 to 41515	39725, 40620, 41515	15 MHz	QPSK	1 RB / 0 RB Offset
		39750 to 41490	39750, 40620, 41490	20 MHz	QPSK	1 RB / 0 RB Offset
-	Radiated Emission	39675 to 41565	39675, 40620, 41565	5 MHz	QPSK	1 RB / 0 RB Offset
		39750 to 41490	39750, 40620, 41490	20 MHz	QPSK	1 RB / 0 RB Offset

Note: This device was tested under all bandwidths, RB configurations and modulations. The worst case was found in QPSK modulation.

Test Condition:

Test Item	Environmental Conditions	Input Power	Tested By
EIRP	25 deg. C, 65 % RH	3.85 Vdc	Thomas Wei
Modulation Characteristics	25 deg. C, 65 % RH	3.85 Vdc	Wayne Lin
Frequency Stability	25 deg. C, 65 % RH	3.85 Vdc	Wayne Lin
Occupied Bandwidth	25 deg. C, 65 % RH	3.85 Vdc	Wayne Lin
Out-of-Band Emissions	25 deg. C, 65 % RH	3.85 Vdc	Wayne Lin
Peak to Average Ratio	25 deg. C, 65 % RH	3.85 Vdc	Wayne Lin
Conducted Emission	25 deg. C, 65 % RH	3.85 Vdc	Wayne Lin
Radiated Emission	25 deg. C, 65 % RH	120 Vac, 60 Hz	Thomas Wei

3.4 EUT Operating Conditions

The EUT makes a call to the communication simulator. The communication simulator station system controlled a EUT to export maximum output power under transmission mode and specific channel frequency

3.5 General Description of Applied Standards

The EUT is a RF Product. According to the specifications of the manufacturer, it must comply with the requirements of the following standards:

FCC 47 CFR Part 2

FCC 47 CFR Part 27

KDB 971168 D01 Power Meas License Digital Systems v03r01

ANSI/TIA/EIA-603-E 2016

ANSI 63.26-2015

Note: All test items have been performed and recorded as per the above standards.

4 Test Types and Results

4.1 Output Power Measurement

4.1.1 Limits of Output Power Measurement

The radiated peak output power shall be according to the specific rule Part 27.50(h)(2) that “Mobile stations are limited to 2.0 watts EIRP. All user stations are limited to 2 watts transmitter output power” and 27.50(i) specific that “Peak transmit power must be measure over any interval of continuous transmission using instrumentation calibration in terms of rms-equivalent voltage.”

4.1.2 Test Procedures

EIRP Measurement:

- a. All measurements were done at low, middle and high operational frequency range. RBW and VBW is 10 MHz for LTE mode.
- b. Substitution method is used for E.I.R.P measurement. In the semi-anechoic chamber, EUT placed on the 0.8 m (below or equal 1 GHz) and/or 1.5 m (above 1 GHz) height of Turn Table, rotated the table around 360 degrees to search the maximum radiation power and receiver antenna shall be rotated vertical and horizontal polarization and moved height from 1 m to 4 m to find the maximum polar radiated power. The “Read Value” is the spectrum reading the maximum power value.
- c. The substitution horn antenna is substituted for EUT at the same position and signals generator export the CW signal to the substitution antenna via a tx cable. Rotated the Turn Table and moved receiving antenna to find the maximum radiation power. Adjust output power level of S.G to get a Value of spectrum reading equal to “Read Value“ of step b. Record the power level of S.G.
- d. $EIRP = \text{Output power level of S.G} - \text{TX cable loss} + \text{Antenna gain of substitution horn}.$

Conducted Power Measurement:

- a. The EUT was set up for the maximum power with LTE link data modulation and link up with simulator.
- b. Set the EUT to transmit under low, middle and high channel and record the power level shown on simulator.

4.1.3 Test Setup

**EIRP / ERP Measurement:
<Radiated Emission below or equal 1 GHz>**

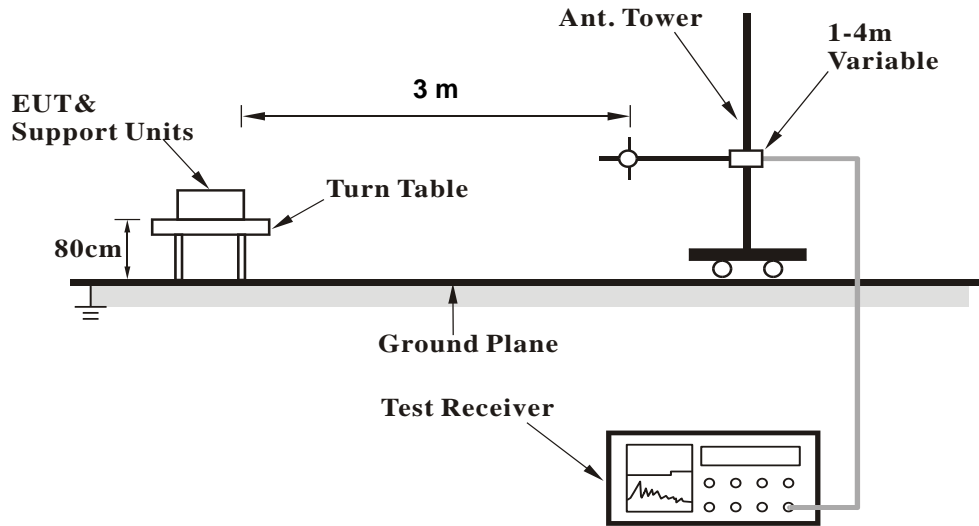

<Radiated Emission above 1 GHz>

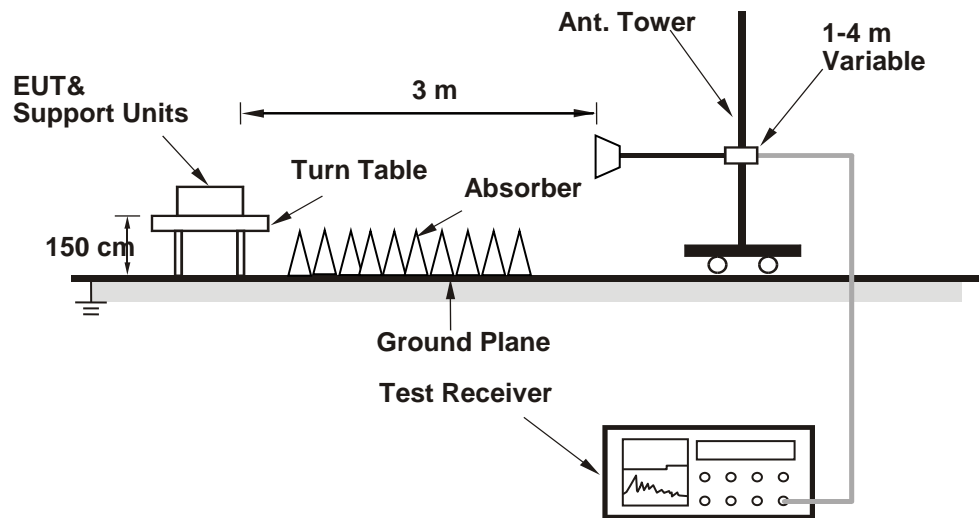

For the actual test configuration, please refer to the attached file (Test Setup Photo).

Conducted Power Measurement:

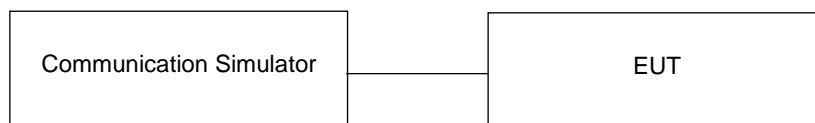

4.1.4 Test Results

The worst configuration mode is presented in the report as below. Please refer to SAR test report for more detail test mode.

Band		TX Antenna	WLAN Function	Body-Worn/Hotspot
LTE	B7	Ant 2	WLAN-Off	Body-Worn/Hotspot
	B38	Ant 2	WLAN-Off	Body-Worn/Hotspot
	B41	Ant 2	WLAN-Off	Body-Worn/Hotspot

Conducted Output Power (dBm)

LTE Band 7																	
Body-Worn / Hotspot																	
Ant-2																	
BW	MCS Index	RB Size	RB Offset	Low	Mid	High	3GPP MPR (dB)	BW	MCS Index	RB Size	RB Offset	Low	Mid	High	3GPP MPR (dB)		
				20850	21100	21350						20825	21100	21375			
		Channel	2510.0	2535.0	2560.0	Channel	2507.5			2535.0	2562.5						
		Frequency (MHz)							Frequency (MHz)								
20M	QPSK	1	0	23.55	23.43	23.34	0	15M	QPSK	1	0	23.49	23.37	23.28	0		
		1	50	23.53	23.41	23.32	0			1	37	23.47	23.35	23.26	0		
		1	99	23.52	23.40	23.31	0			1	74	23.46	23.34	23.25	0		
		50	0	22.64	22.52	22.43	1			36	0	22.58	22.46	22.37	1		
		50	25	22.60	22.48	22.39	1			36	19	22.54	22.42	22.33	1		
		50	50	22.58	22.46	22.37	1			36	39	22.52	22.40	22.31	1		
	100	0	22.63	22.51	22.42	1	75		0	22.57	22.45	22.36	1				
	16QAM	1	0	22.53	22.41	22.32	1		1	0	22.47	22.35	22.26	1			
		1	50	22.51	22.39	22.30	1		1	37	22.45	22.33	22.24	1			
		1	99	22.50	22.38	22.29	1		1	74	22.44	22.32	22.23	1			
		50	0	21.62	21.50	21.41	2		36	0	21.56	21.44	21.35	2			
		50	25	21.58	21.46	21.37	2		36	19	21.52	21.40	21.31	2			
		50	50	21.56	21.44	21.35	2		36	39	21.50	21.38	21.29	2			
	100	0	21.61	21.49	21.40	2	75		0	21.55	21.43	21.34	2				
	64QAM	1	0	21.55	21.43	21.34	2		1	0	21.49	21.37	21.28	2			
		1	50	21.53	21.41	21.32	2		1	37	21.47	21.35	21.26	2			
		1	99	21.52	21.40	21.31	2		1	74	21.46	21.34	21.25	2			
		50	0	20.64	20.52	20.43	3		36	0	20.58	20.46	20.37	3			
		50	25	20.60	20.48	20.39	3		36	19	20.54	20.42	20.33	3			
		50	50	20.58	20.46	20.37	3		36	39	20.52	20.40	20.31	3			
	100	0	20.63	20.51	20.42	3	75		0	20.57	20.45	20.36	3				
	10M	QPSK	1	0	23.44	23.32	23.23		0	5M	QPSK	1	0	23.41	23.29	23.20	0
			1	24	23.42	23.30	23.21		0			1	12	23.39	23.27	23.18	0
			1	49	23.41	23.29	23.20		0			1	24	23.38	23.26	23.17	0
25			0	22.53	22.41	22.32	1	12	0			22.50	22.38	22.29	1		
25			12	22.49	22.37	22.28	1	12	6			22.46	22.34	22.25	1		
25			25	22.47	22.35	22.26	1	12	13			22.44	22.32	22.23	1		
50		0	22.52	22.40	22.31	1	25	0	22.49		22.37	22.28	1				
16QAM		1	0	22.42	22.30	22.21	1	1	0		22.39	22.27	22.18	1			
		1	24	22.40	22.28	22.19	1	1	12		22.37	22.25	22.16	1			
		1	49	22.39	22.27	22.18	1	1	24		22.36	22.24	22.15	1			
		25	0	21.51	21.39	21.30	2	12	0		21.48	21.36	21.27	2			
		25	12	21.47	21.35	21.26	2	12	6		21.44	21.32	21.23	2			
		25	25	21.45	21.33	21.24	2	12	13		21.42	21.30	21.21	2			
50		0	21.50	21.38	21.29	2	25	0	21.47		21.35	21.26	2				
64QAM		1	0	21.44	21.32	21.23	2	1	0		21.41	21.29	21.20	2			
		1	24	21.42	21.30	21.21	2	1	12		21.39	21.27	21.18	2			
		1	49	21.41	21.29	21.20	2	1	24		21.38	21.26	21.17	2			
		25	0	20.53	20.41	20.32	3	12	0		20.50	20.38	20.29	3			
		25	12	20.49	20.37	20.28	3	12	6		20.46	20.34	20.25	3			
		25	25	20.47	20.35	20.26	3	12	13		20.44	20.32	20.23	3			
50		0	20.52	20.40	20.31	3	25	0	20.49		20.37	20.28	3				

LTE Band 38

Body-Worn / Hotspot

Ant-2

BW	MCS Index	RB Size	RB Offset	Low	Mid	High	3GPP MPR (dB)	BW	MCS Index	RB Size	RB Offset	Low	Mid	High	3GPP MPR (dB)		
				37850	38000	38150						37825	38000	38175			
				Channel	2580.0	2595.0						2610.0	Channel	2577.5		2595.0	2612.5
		Frequency (MHz)							Frequency (MHz)								
20M	QPSK	1	0	24.61	24.66	24.63	0	15M	QPSK	1	0	24.57	24.62	24.59	0		
		1	50	24.59	24.64	24.61	0			1	37	24.55	24.60	24.57	0		
		1	99	24.57	24.62	24.59	0			1	74	24.53	24.58	24.55	0		
		50	0	23.71	23.76	23.73	1			36	0	23.67	23.72	23.69	1		
		50	25	23.68	23.73	23.70	1			36	19	23.64	23.69	23.66	1		
		50	50	23.64	23.69	23.66	1			36	39	23.60	23.65	23.62	1		
	16QAM	100	0	23.66	23.71	23.68	1		75	0	23.62	23.67	23.64	1			
		1	0	23.59	23.64	23.61	1		16QAM	1	0	23.55	23.60	23.57	1		
		1	50	23.57	23.62	23.59	1			1	37	23.53	23.58	23.55	1		
		1	99	23.55	23.60	23.57	1			1	74	23.51	23.56	23.53	1		
		50	0	22.69	22.74	22.71	2			36	0	22.65	22.70	22.67	2		
		50	25	22.66	22.71	22.68	2			36	19	22.62	22.67	22.64	2		
	50	50	22.62	22.67	22.64	2	36			39	22.58	22.63	22.60	2			
	64QAM	100	0	22.64	22.69	22.66	2		75	0	22.60	22.65	22.62	2			
		1	0	22.61	22.66	22.63	2		64QAM	1	0	22.57	22.62	22.59	2		
		1	50	22.59	22.64	22.61	2			1	37	22.55	22.60	22.57	2		
		1	99	22.57	22.62	22.59	2			1	74	22.53	22.58	22.55	2		
		50	0	21.71	21.76	21.73	3			36	0	21.67	21.72	21.69	3		
		50	25	21.68	21.73	21.70	3			36	19	21.64	21.69	21.66	3		
	50	50	21.64	21.69	21.66	3	36			39	21.60	21.65	21.62	3			
	10M	QPSK	100	0	21.66	21.71	21.68		3	75	0	21.62	21.67	21.64	3		
			1	0	24.52	24.57	24.54		0	5M	QPSK	1	0	24.49	24.54	24.51	0
			1	24	24.50	24.55	24.52		0			1	12	24.47	24.52	24.49	0
			1	49	24.48	24.53	24.50		0			1	24	24.45	24.50	24.47	0
25			0	23.62	23.67	23.64	1	12	0			23.59	23.64	23.61	1		
25			12	23.59	23.64	23.61	1	12	6			23.56	23.61	23.58	1		
25		25	23.55	23.60	23.57	1	12	13	23.52			23.57	23.54	1			
16QAM		50	0	23.57	23.62	23.59	1	25	0		23.54	23.59	23.56	1			
		1	0	23.50	23.55	23.52	1	16QAM	1		0	23.47	23.52	23.49	1		
		1	24	23.48	23.53	23.50	1		1		12	23.45	23.50	23.47	1		
		1	49	23.46	23.51	23.48	1		1		24	23.43	23.48	23.45	1		
		25	0	22.60	22.65	22.62	2		12		0	22.57	22.62	22.59	2		
		25	12	22.57	22.62	22.59	2		12		6	22.54	22.59	22.56	2		
25		25	22.53	22.58	22.55	2	12		13		22.50	22.55	22.52	2			
64QAM		50	0	22.55	22.60	22.57	2	25	0		22.52	22.57	22.54	2			
		1	0	22.52	22.57	22.54	2	64QAM	1		0	22.49	22.54	22.51	2		
		1	24	22.50	22.55	22.52	2		1		12	22.47	22.52	22.49	2		
		1	49	22.48	22.53	22.50	2		1		24	22.45	22.50	22.47	2		
		25	0	21.62	21.67	21.64	3		12		0	21.59	21.64	21.61	3		
		25	12	21.59	21.64	21.61	3		12		6	21.56	21.61	21.58	3		
25		25	21.55	21.60	21.57	3	12		13		21.52	21.57	21.54	3			
50		0	21.57	21.62	21.59	3	25	0	21.54		21.59	21.56	3				

LTE Band 41
Body-Worn / Hotspot
Ant-2

BW	MCS Index	RB Size	RB Offset	Low	Mid	High	3GPP MPR (dB)	BW	MCS Index	RB Size	RB Offset	Low	Mid	High	3GPP MPR (dB)		
				Channel	39750	40620						41490	Channel	39725		40620	41515
				Frequency (MHz)	2506.0	2593.0						2680.0	Frequency (MHz)	2503.5		2593.0	2682.5
20M	QPSK	1	0	23.96	23.93	23.88	0	15M	QPSK	1	0	23.88	23.85	23.80	0		
		1	50	23.93	23.90	23.85	0			1	37	23.85	23.82	23.77	0		
		1	99	23.99	23.96	23.91	0			1	74	23.91	23.88	23.83	0		
		50	0	23.11	23.08	23.03	1			36	0	23.03	23.00	22.95	1		
		50	25	23.14	23.11	23.06	1			36	19	23.06	23.03	22.98	1		
		50	50	23.12	23.09	23.04	1			36	39	23.04	23.01	22.96	1		
		100	0	23.12	23.09	23.04	1			75	0	23.04	23.01	22.96	1		
	16QAM	1	0	23.27	23.24	23.19	1		16QAM	1	0	23.22	23.19	23.14	1		
		1	50	23.25	23.22	23.17	1			1	37	23.20	23.17	23.12	1		
		1	99	23.28	23.25	23.20	1			1	74	23.23	23.20	23.15	1		
		50	0	22.19	22.16	22.11	2			36	0	22.14	22.11	22.06	2		
		50	25	22.19	22.16	22.11	2			36	19	22.14	22.11	22.06	2		
		50	50	22.17	22.14	22.09	2			36	39	22.12	22.09	22.04	2		
		100	0	22.18	22.15	22.10	2			75	0	22.13	22.10	22.05	2		
	64QAM	1	0	22.20	22.17	22.12	2		64QAM	1	0	22.13	22.10	22.05	2		
		1	50	22.18	22.15	22.10	2			1	37	22.11	22.08	22.03	2		
		1	99	22.21	22.18	22.13	2			1	74	22.14	22.11	22.06	2		
		50	0	21.12	21.09	21.04	3			36	0	21.05	21.02	20.97	3		
		50	25	21.12	21.09	21.04	3			36	19	21.05	21.02	20.97	3		
		50	50	21.10	21.07	21.02	3			36	39	21.03	21.00	20.95	3		
		100	0	21.11	21.08	21.03	3			75	0	21.04	21.01	20.96	3		
	10M	QPSK	1	0	23.86	23.83	23.78		0	5M	QPSK	1	0	23.82	23.79	23.74	0
			1	24	23.83	23.80	23.75		0			1	12	23.79	23.76	23.71	0
			1	49	23.89	23.86	23.81		0			1	24	23.85	23.82	23.77	0
25			0	23.01	22.98	22.93	1	12	0			22.97	22.94	22.89	1		
25			12	23.04	23.01	22.96	1	12	6			23.00	22.97	22.92	1		
25			25	23.02	22.99	22.94	1	12	13			22.98	22.95	22.90	1		
50			0	23.02	22.99	22.94	1	25	0			22.98	22.95	22.90	1		
16QAM		1	0	23.17	23.14	23.09	1	16QAM	1		0	23.16	23.13	23.08	1		
		1	24	23.15	23.12	23.07	1		1		12	23.14	23.11	23.06	1		
		1	49	23.18	23.15	23.10	1		1		24	23.17	23.14	23.09	1		
		25	0	22.09	22.06	22.01	2		12		0	22.08	22.05	22.00	2		
		25	12	22.09	22.06	22.01	2		12		6	22.08	22.05	22.00	2		
		25	25	22.07	22.04	21.99	2		12		13	22.06	22.03	21.98	2		
		50	0	22.08	22.05	22.00	2		25		0	22.07	22.04	21.99	2		
64QAM		1	0	22.10	22.07	22.02	2	64QAM	1		0	22.07	22.04	21.99	2		
		1	24	22.08	22.05	22.00	2		1		12	22.05	22.02	21.97	2		
		1	49	22.11	22.08	22.03	2		1		24	22.08	22.05	22.00	2		
		25	0	21.02	20.99	20.94	3		12		0	20.99	20.96	20.91	3		
		25	12	21.02	20.99	20.94	3		12		6	20.99	20.96	20.91	3		
		25	25	21.00	20.97	20.92	3		12		13	20.97	20.94	20.89	3		
		50	0	21.01	20.98	20.93	3		25		0	20.98	20.95	20.90	3		

EIRP Power (dBm)

LTE Band 7							
Channel Bandwidth: 5 MHz / QPSK							
Plane	Channel	Frequency (MHz)	Reading (dBm)	Correction Factor (dB)	EIRP (dBm)	EIRP (mW)	Polarization (H/V)
X	20775	2502.5	-16.93	38.52	21.59	144.21	H
	21100	2535.0	-16.93	38.36	21.43	139.00	
	21425	2567.5	-17.25	38.58	21.33	135.83	
	20775	2502.5	-21.79	38.92	17.13	51.64	V
	21100	2535.0	-22.59	39.26	16.67	46.45	
	21425	2567.5	-22.91	39.22	16.31	42.76	
Channel Bandwidth: 5 MHz / 16QAM							
X	20775	2502.5	-17.93	38.52	20.59	114.55	H
	21100	2535.0	-17.93	38.36	20.43	110.41	
	21425	2567.5	-18.25	38.58	20.33	107.89	
	20775	2502.5	-22.79	38.92	16.13	41.02	V
	21100	2535.0	-23.59	39.26	15.67	36.90	
	21425	2567.5	-23.91	39.22	15.31	33.96	
Channel Bandwidth: 5 MHz / 64QAM							
X	20775	2502.5	-18.95	38.52	19.57	90.57	H
	21100	2535.0	-18.95	38.36	19.41	87.30	
	21425	2567.5	-19.27	38.58	19.31	85.31	
	20775	2502.5	-23.81	38.92	15.11	32.43	V
	21100	2535.0	-24.61	39.26	14.65	29.17	
	21425	2567.5	-24.93	39.22	14.29	26.85	

Note: EIRP (dBm) = Reading (dBm) + Correction Factor (dB)

LTE Band 7							
Channel Bandwidth: 10 MHz / QPSK							
Plane	Channel	Frequency (MHz)	Reading (dBm)	Correction Factor (dB)	EIRP (dBm)	EIRP (mW)	Polarization (H/V)
X	20800	2505.0	-16.82	38.65	21.83	152.41	H
	21100	2535.0	-16.69	38.36	21.67	146.89	
	21400	2565.0	-16.92	38.49	21.57	143.55	
	20800	2505.0	-21.47	38.84	17.37	54.58	V
	21100	2535.0	-22.35	39.26	16.91	49.09	
	21400	2565.0	-22.55	39.10	16.55	45.19	
Channel Bandwidth: 10 MHz / 16QAM							
X	20800	2505.0	-17.82	38.65	20.83	121.06	H
	21100	2535.0	-17.69	38.36	20.67	116.68	
	21400	2565.0	-17.92	38.49	20.57	114.02	
	20800	2505.0	-22.47	38.84	16.37	43.35	V
	21100	2535.0	-23.35	39.26	15.91	38.99	
	21400	2565.0	-23.55	39.10	15.55	35.89	
Channel Bandwidth: 10 MHz / 64QAM							
X	20800	2505.0	-18.85	38.65	19.80	95.50	H
	21100	2535.0	-18.72	38.36	19.64	92.04	
	21400	2565.0	-18.95	38.49	19.54	89.95	
	20800	2505.0	-23.50	38.84	15.34	34.20	V
	21100	2535.0	-24.38	39.26	14.88	30.76	
	21400	2565.0	-24.58	39.10	14.52	28.31	

Note: EIRP (dBm) = Reading (dBm) + Correction Factor (dB)

LTE Band 7							
Channel Bandwidth: 15 MHz / QPSK							
Plane	Channel	Frequency (MHz)	Reading (dBm)	Correction Factor (dB)	EIRP (dBm)	EIRP (mW)	Polarization (H/V)
X	20825	2507.5	-16.46	38.52	22.06	160.69	H
	21100	2535.0	-16.46	38.36	21.90	154.88	
	21375	2562.5	-16.78	38.58	21.80	151.36	
	20825	2507.5	-21.32	38.92	17.60	57.54	V
	21100	2535.0	-22.12	39.26	17.14	51.76	
	21375	2562.5	-22.44	39.22	16.78	47.64	
Channel Bandwidth: 15 MHz / 16QAM							
X	20825	2507.5	-17.46	38.52	21.06	127.64	H
	21100	2535.0	-17.46	38.36	20.90	123.03	
	21375	2562.5	-17.78	38.58	20.80	120.23	
	20825	2507.5	-22.32	38.92	16.60	45.71	V
	21100	2535.0	-23.12	39.26	16.14	41.11	
	21375	2562.5	-23.44	39.22	15.78	37.84	
Channel Bandwidth: 15 MHz / 64QAM							
X	20825	2507.5	-18.48	38.52	20.04	100.93	H
	21100	2535.0	-18.48	38.36	19.88	97.27	
	21375	2562.5	-18.80	38.58	19.78	95.06	
	20825	2507.5	-23.34	38.92	15.58	36.14	V
	21100	2535.0	-24.14	39.26	15.12	32.51	
	21375	2562.5	-24.46	39.22	14.76	29.92	

Note: EIRP (dBm) = Reading (dBm) + Correction Factor (dB)

LTE Band 7							
Channel Bandwidth: 20 MHz / QPSK							
Plane	Channel	Frequency (MHz)	Reading (dBm)	Correction Factor (dB)	EIRP (dBm)	EIRP (mW)	Polarization (H/V)
X	20850	2510.0	-16.21	38.52	22.31	170.22	H
	21100	2535.0	-16.21	38.36	22.15	164.06	
	21350	2560.0	-16.53	38.58	22.05	160.32	
	20850	2510.0	-21.07	38.92	17.85	60.95	V
	21100	2535.0	-21.87	39.26	17.39	54.83	
	21350	2560.0	-22.19	39.22	17.03	50.47	
Channel Bandwidth: 20 MHz / 16QAM							
X	20850	2510.0	-17.23	38.52	21.29	134.59	H
	21100	2535.0	-17.23	38.36	21.13	129.72	
	21350	2560.0	-17.55	38.58	21.03	126.77	
	20850	2510.0	-22.09	38.92	16.83	48.19	V
	21100	2535.0	-22.89	39.26	16.37	43.35	
	21350	2560.0	-23.21	39.22	16.01	39.90	
Channel Bandwidth: 20 MHz / 64QAM							
X	20850	2510.0	-18.25	38.52	20.27	106.41	H
	21100	2535.0	-18.25	38.36	20.11	102.57	
	21350	2560.0	-18.57	38.58	20.01	100.23	
	20850	2510.0	-23.11	38.92	15.81	38.11	V
	21100	2535.0	-23.91	39.26	15.35	34.28	
	21350	2560.0	-24.23	39.22	14.99	31.55	

Note: EIRP (dBm) = Reading (dBm) + Correction Factor (dB)

LTE Band 38							
Channel Bandwidth: 5 MHz / QPSK							
Plane	Channel	Frequency (MHz)	Reading (dBm)	Correction Factor (dB)	EIRP (dBm)	EIRP (mW)	Polarization (H/V)
X	37775	2572.5	-17.85	38.99	21.14	130.02	H
	38000	2595.0	-16.63	38.17	21.54	142.56	
	38225	2617.5	-17.21	38.55	21.34	136.14	
	37775	2572.5	-22.20	39.27	17.07	50.93	V
	38000	2595.0	-21.10	38.68	17.58	57.28	
	38225	2617.5	-21.36	38.55	17.19	52.36	
Channel Bandwidth: 5 MHz / 16QAM							
X	37775	2572.5	-18.57	38.99	20.42	110.15	H
	38000	2595.0	-17.35	38.17	20.82	120.78	
	38225	2617.5	-17.93	38.55	20.62	115.35	
	37775	2572.5	-22.92	39.27	16.35	43.15	V
	38000	2595.0	-21.82	38.68	16.86	48.53	
	38225	2617.5	-22.08	38.55	16.47	44.36	
Channel Bandwidth: 5 MHz / 64QAM							
X	37775	2572.5	-19.61	38.99	19.38	86.70	H
	38000	2595.0	-18.39	38.17	19.78	95.06	
	38225	2617.5	-18.97	38.55	19.58	90.78	
	37775	2572.5	-23.96	39.27	15.31	33.96	V
	38000	2595.0	-22.86	38.68	15.82	38.19	
	38225	2617.5	-23.12	38.55	15.43	34.91	

Note: EIRP (dBm) = Reading (dBm) + Correction Factor (dB)

LTE Band 38							
Channel Bandwidth: 10 MHz / QPSK							
Plane	Channel	Frequency (MHz)	Reading (dBm)	Correction Factor (dB)	EIRP (dBm)	EIRP (mW)	Polarization (H/V)
X	37800	2575.0	-17.60	38.98	21.38	137.40	H
	38000	2595.0	-16.39	38.17	21.78	150.66	
	38200	2615.0	-16.87	38.45	21.58	143.88	
	37800	2575.0	-21.73	39.04	17.31	53.83	V
	38000	2595.0	-20.86	38.68	17.82	60.53	
	38200	2615.0	-21.17	38.60	17.43	55.34	
Channel Bandwidth: 10 MHz / 16QAM							
X	37800	2575.0	-18.35	38.98	20.63	115.61	H
	38000	2595.0	-17.14	38.17	21.03	126.77	
	38200	2615.0	-17.62	38.45	20.83	121.06	
	37800	2575.0	-22.48	39.04	16.56	45.29	V
	38000	2595.0	-21.61	38.68	17.07	50.93	
	38200	2615.0	-21.92	38.60	16.68	46.56	
Channel Bandwidth: 10 MHz / 64QAM							
X	37800	2575.0	-19.37	38.98	19.61	91.41	H
	38000	2595.0	-18.16	38.17	20.01	100.23	
	38200	2615.0	-18.64	38.45	19.81	95.72	
	37800	2575.0	-23.50	39.04	15.54	35.81	V
	38000	2595.0	-22.63	38.68	16.05	40.27	
	38200	2615.0	-22.94	38.60	15.66	36.81	

Note: EIRP (dBm) = Reading (dBm) + Correction Factor (dB)

LTE Band 38							
Channel Bandwidth: 15 MHz / QPSK							
Plane	Channel	Frequency (MHz)	Reading (dBm)	Correction Factor (dB)	EIRP (dBm)	EIRP (mW)	Polarization (H/V)
X	37825	2577.5	-17.25	39.09	21.84	152.76	H
	38000	2595.0	-15.93	38.17	22.24	167.49	
	38175	2612.5	-16.48	38.52	22.04	159.96	
	37825	2577.5	-21.27	39.04	17.77	59.84	V
	38000	2595.0	-20.40	38.68	18.28	67.30	
	38175	2612.5	-20.77	38.66	17.89	61.52	
Channel Bandwidth: 15 MHz / 16QAM							
X	37825	2577.5	-18.24	39.09	20.85	121.62	H
	38000	2595.0	-16.92	38.17	21.25	133.35	
	38175	2612.5	-17.47	38.52	21.05	127.35	
	37825	2577.5	-22.26	39.04	16.78	47.64	V
	38000	2595.0	-21.39	38.68	17.29	53.58	
	38175	2612.5	-21.76	38.66	16.90	48.98	
Channel Bandwidth: 15 MHz / 64QAM							
X	37825	2577.5	-19.24	39.09	19.85	96.61	H
	38000	2595.0	-17.92	38.17	20.25	105.93	
	38175	2612.5	-18.47	38.52	20.05	101.16	
	37825	2577.5	-23.26	39.04	15.78	37.84	V
	38000	2595.0	-22.39	38.68	16.29	42.56	
	38175	2612.5	-22.76	38.66	15.90	38.90	

Note: EIRP (dBm) = Reading (dBm) + Correction Factor (dB)

LTE Band 38							
Channel Bandwidth: 20 MHz / QPSK							
Plane	Channel	Frequency (MHz)	Reading (dBm)	Correction Factor (dB)	EIRP (dBm)	EIRP (mW)	Polarization (H/V)
X	37850	2580.0	-17.18	39.26	22.08	161.44	H
	38000	2595.0	-15.69	38.17	22.48	177.01	
	38150	2610.0	-16.43	38.71	22.28	169.04	
	37850	2580.0	-21.32	39.33	18.01	63.24	V
	38000	2595.0	-20.16	38.68	18.52	71.12	
	38150	2610.0	-20.63	38.76	18.13	65.01	
Channel Bandwidth: 20 MHz / 16QAM							
X	37850	2580.0	-18.17	39.26	21.09	128.53	H
	38000	2595.0	-16.68	38.17	21.49	140.93	
	38150	2610.0	-17.42	38.71	21.29	134.59	
	37850	2580.0	-22.31	39.33	17.02	50.35	V
	38000	2595.0	-21.15	38.68	17.53	56.62	
	38150	2610.0	-21.62	38.76	17.14	51.76	
Channel Bandwidth: 20 MHz / 64QAM							
X	37850	2580.0	-19.18	39.26	20.08	101.86	H
	38000	2595.0	-17.69	38.17	20.48	111.69	
	38150	2610.0	-18.43	38.71	20.28	106.66	
	37850	2580.0	-23.32	39.33	16.01	39.90	V
	38000	2595.0	-22.16	38.68	16.52	44.87	
	38150	2610.0	-22.63	38.76	16.13	41.02	

Note: EIRP (dBm) = Reading (dBm) + Correction Factor (dB)

LTE Band 41							
Channel Bandwidth: 5 MHz / QPSK							
Plane	Channel	Frequency (MHz)	Reading (dBm)	Correction Factor (dB)	EIRP (dBm)	EIRP (mW)	Polarization (H/V)
X	39675	2498.5	-17.11	38.99	21.88	154.17	H
	40620	2593.0	-16.11	38.17	22.06	160.69	
	41565	2687.5	-16.31	38.55	22.24	167.49	
	39675	2498.5	-23.67	39.27	15.60	36.31	V
	40620	2593.0	-22.97	38.68	15.71	37.24	
	41565	2687.5	-22.71	38.55	15.84	38.37	
Channel Bandwidth: 5 MHz / 16QAM							
X	39675	2498.5	-18.13	38.99	20.86	121.90	H
	40620	2593.0	-17.13	38.17	21.04	127.06	
	41565	2687.5	-17.33	38.55	21.22	132.43	
	39675	2498.5	-24.69	39.27	14.58	28.71	V
	40620	2593.0	-23.99	38.68	14.69	29.44	
	41565	2687.5	-23.73	38.55	14.82	30.34	
Channel Bandwidth: 5 MHz / 64QAM							
X	39675	2498.5	-19.12	38.99	19.87	97.05	H
	40620	2593.0	-18.12	38.17	20.05	101.16	
	41565	2687.5	-18.32	38.55	20.23	105.44	
	39675	2498.5	-25.68	39.27	13.59	22.86	V
	40620	2593.0	-24.98	38.68	13.70	23.44	
	41565	2687.5	-24.72	38.55	13.83	24.15	

Note: EIRP (dBm) = Reading (dBm) + Correction Factor (dB)

LTE Band 41							
Channel Bandwidth: 10 MHz / QPSK							
Plane	Channel	Frequency (MHz)	Reading (dBm)	Correction Factor (dB)	EIRP (dBm)	EIRP (mW)	Polarization (H/V)
X	39700	2501.0	-16.89	38.98	22.09	161.81	H
	40620	2593.0	-15.90	38.17	22.27	168.66	
	41540	2685.0	-16.00	38.45	22.45	175.79	
	39700	2501.0	-23.23	39.04	15.81	38.11	V
	40620	2593.0	-22.76	38.68	15.92	39.08	
	41540	2685.0	-22.55	38.60	16.05	40.27	
Channel Bandwidth: 10 MHz / 16QAM							
X	39700	2501.0	-17.88	38.98	21.10	128.82	H
	40620	2593.0	-16.89	38.17	21.28	134.28	
	41540	2685.0	-16.99	38.45	21.46	139.96	
	39700	2501.0	-24.22	39.04	14.82	30.34	V
	40620	2593.0	-23.75	38.68	14.93	31.12	
	41540	2685.0	-23.54	38.60	15.06	32.06	
Channel Bandwidth: 10 MHz / 64QAM							
X	39700	2501.0	-18.89	38.98	20.09	102.09	H
	40620	2593.0	-17.90	38.17	20.27	106.41	
	41540	2685.0	-18.00	38.45	20.45	110.92	
	39700	2501.0	-25.23	39.04	13.81	24.04	V
	40620	2593.0	-24.76	38.68	13.92	24.66	
	41540	2685.0	-24.55	38.60	14.05	25.41	

Note: EIRP (dBm) = Reading (dBm) + Correction Factor (dB)

LTE Band 41							
Channel Bandwidth: 15 MHz / QPSK							
Plane	Channel	Frequency (MHz)	Reading (dBm)	Correction Factor (dB)	EIRP (dBm)	EIRP (mW)	Polarization (H/V)
X	39725	2503.5	-16.76	39.09	22.33	171.00	H
	40620	2593.0	-15.66	38.17	22.51	178.24	
	41515	2682.5	-15.83	38.52	22.69	185.78	
	39725	2503.5	-22.99	39.04	16.05	40.27	V
	40620	2593.0	-22.52	38.68	16.16	41.30	
	41515	2682.5	-22.37	38.66	16.29	42.56	
Channel Bandwidth: 15 MHz / 16QAM							
X	39725	2503.5	-17.77	39.09	21.32	135.52	H
	40620	2593.0	-16.67	38.17	21.50	141.25	
	41515	2682.5	-16.84	38.52	21.68	147.23	
	39725	2503.5	-24.00	39.04	15.04	31.92	V
	40620	2593.0	-23.53	38.68	15.15	32.73	
	41515	2682.5	-23.38	38.66	15.28	33.73	
Channel Bandwidth: 15 MHz / 64QAM							
X	39725	2503.5	-18.77	39.09	20.32	107.65	H
	40620	2593.0	-17.67	38.17	20.50	112.20	
	41515	2682.5	-17.84	38.52	20.68	116.95	
	39725	2503.5	-25.00	39.04	14.04	25.35	V
	40620	2593.0	-24.53	38.68	14.15	26.00	
	41515	2682.5	-24.38	38.66	14.28	26.79	

Note: EIRP (dBm) = Reading (dBm) + Correction Factor (dB)

LTE Band 41							
Channel Bandwidth: 20 MHz / QPSK							
Plane	Channel	Frequency (MHz)	Reading (dBm)	Correction Factor (dB)	EIRP (dBm)	EIRP (mW)	Polarization (H/V)
X	39750	2506.0	-16.70	39.26	22.56	180.30	H
	40620	2593.0	-15.43	38.17	22.74	187.93	
	41490	2680.0	-15.79	38.71	22.92	195.88	
	39750	2506.0	-23.05	39.33	16.28	42.46	V
	40620	2593.0	-22.29	38.68	16.39	43.55	
	41490	2680.0	-22.24	38.76	16.52	44.87	
Channel Bandwidth: 20 MHz / 16QAM							
X	39750	2506.0	-17.71	39.26	21.55	142.89	H
	40620	2593.0	-16.44	38.17	21.73	148.94	
	41490	2680.0	-16.80	38.71	21.91	155.24	
	39750	2506.0	-24.06	39.33	15.27	33.65	V
	40620	2593.0	-23.30	38.68	15.38	34.51	
	41490	2680.0	-23.25	38.76	15.51	35.56	
Channel Bandwidth: 20 MHz / 64QAM							
X	39750	2506.0	-18.70	39.26	20.56	113.76	H
	40620	2593.0	-17.43	38.17	20.74	118.58	
	41490	2680.0	-17.79	38.71	20.92	123.59	
	39750	2506.0	-25.05	39.33	14.28	26.79	V
	40620	2593.0	-24.29	38.68	14.39	27.48	
	41490	2680.0	-24.24	38.76	14.52	28.31	

Note: EIRP (dBm) = Reading (dBm) + Correction Factor (dB)

4.2 Modulation Characteristics Measurement

4.2.1 Limits of Modulation Characteristics

N/A

4.2.2 Test Setup



4.2.3 Test Procedure

Connect the EUT to Communication Simulator via the antenna connector. The frequency band is set as EUT supported Modulation and Channels, the EUT output is matched with 50 ohm load, the waveform quality and constellation of the EUT was tested.

4.2.4 Test Results

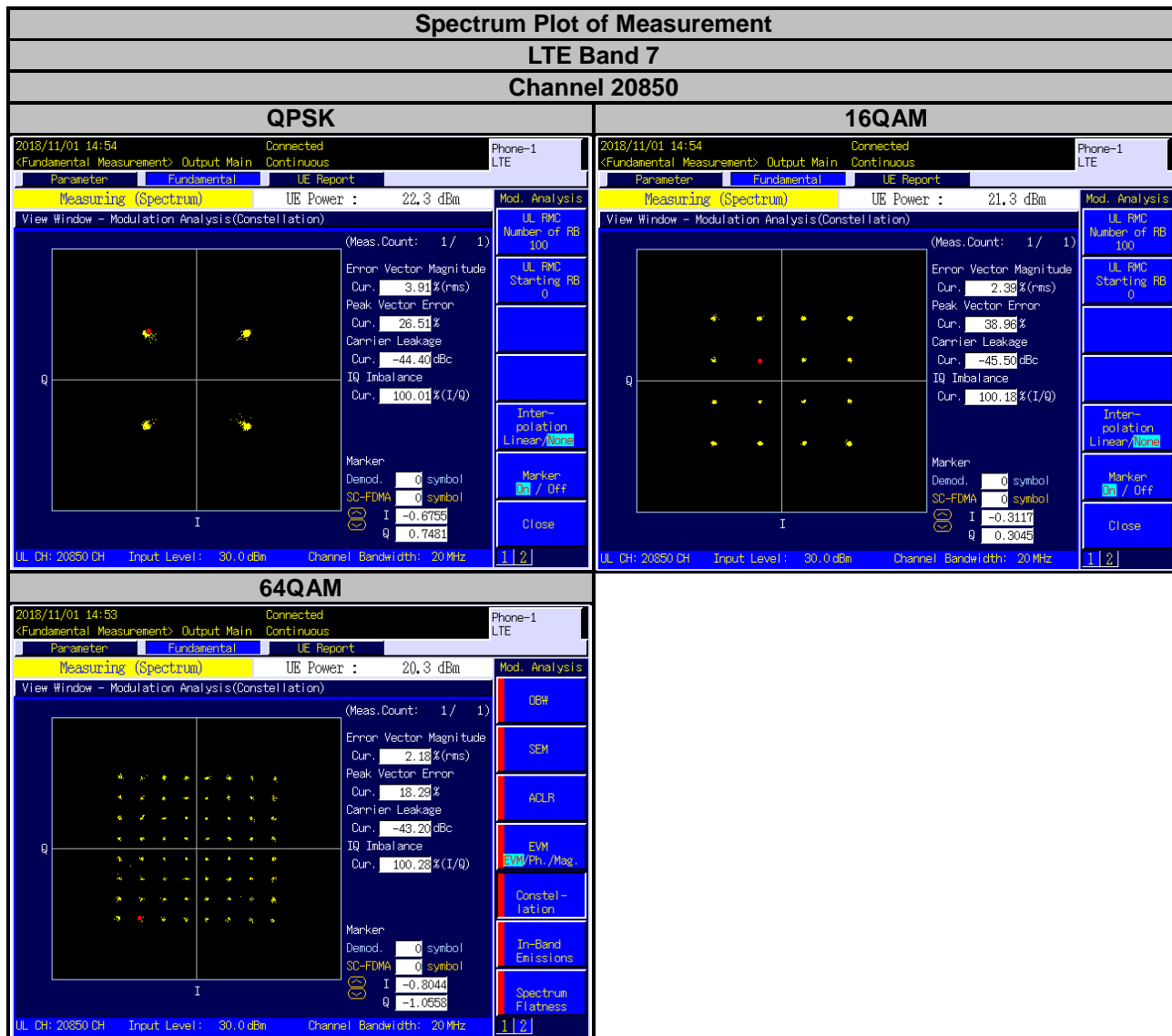

Spectrum Plot of Measurement

LTE Band 38

Channel 37850

QPSK

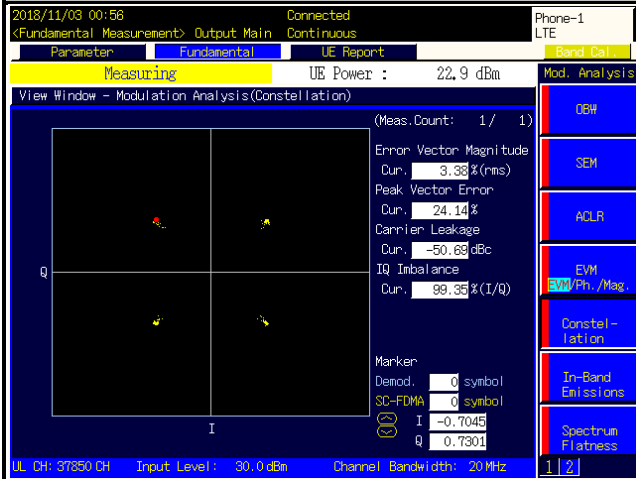

16QAM

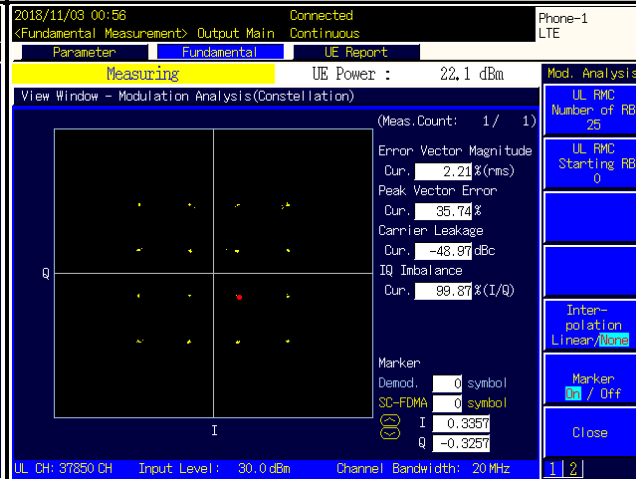

64QAM

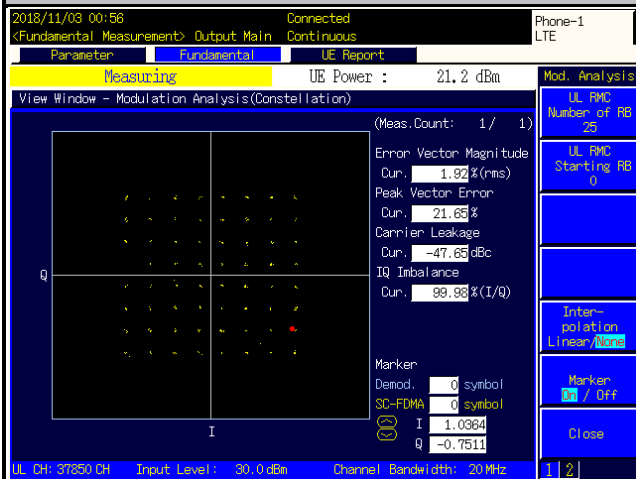

Spectrum Plot of Measurement

LTE Band 41

Channel 39750

QPSK

16QAM

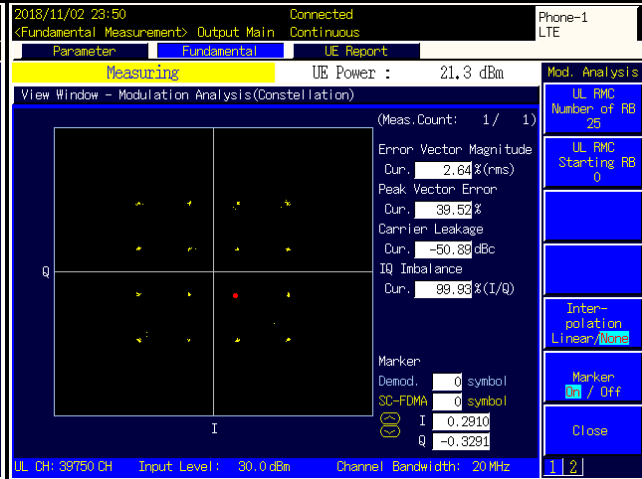
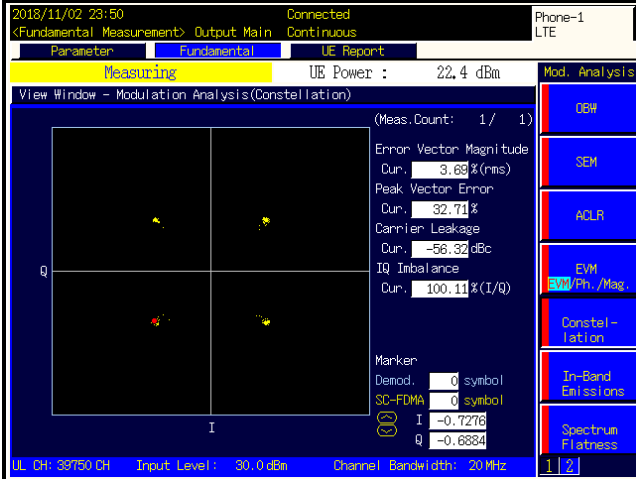

64QAM

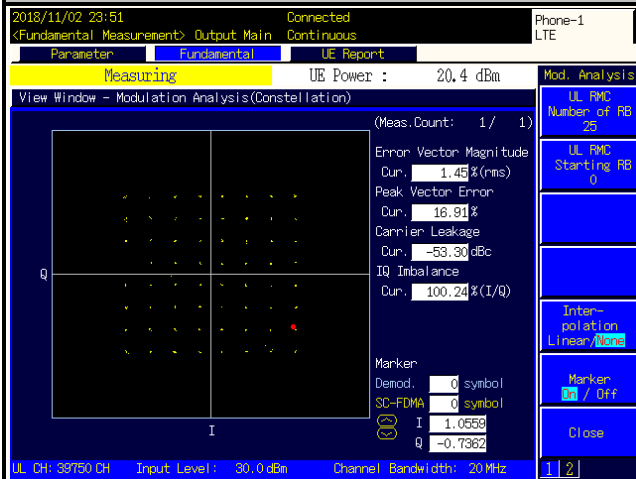

4.3 Frequency Stability Measurement

4.3.1 Limits of Frequency Stability Measurement

According to the FCC part 2.1055 shall be tested the frequency stability. The rule is defined that "The frequency stability shall be sufficient to ensure that the fundamental emission stays within the authorized frequency block." The test extreme voltage is according to the 2.1055(d)(1) Vary primary supply voltage from 85 to 115 percent of the nominal value for other than hand carried battery equipment and the extreme temperature rule is comply with specification of EUT $-30^{\circ}\text{C} \sim 50^{\circ}\text{C}$.

4.3.2 Test Procedure

- Device is placed at the oven room. The oven room could control the temperatures and humidity. Power warm up is at least 15 min and power applied should perform before recording frequency error.
- EUT is connected the external power supply to control the DC input power. The test voltage range is from minimum to maximum working voltage. Each step shall be record the frequency error rate.
- The temperature range step is 10 degrees in this test items. All temperature levels shall be hold the $\pm 0.5^{\circ}\text{C}$ during the measurement testing. The each temperature step shall be at least 0.5 hours, consider the EUT could be test under the stability condition.

NOTE: The frequency error was recorded frequency error from the communication simulator.

4.3.3 Test Setup

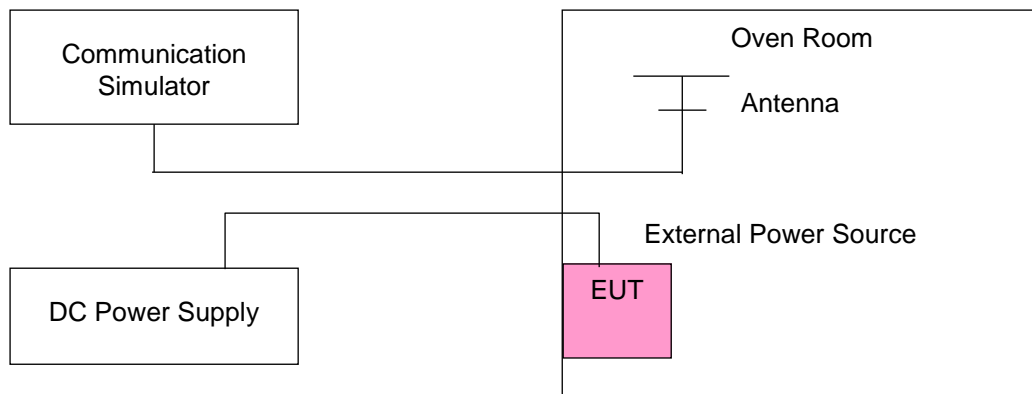

4.3.4 Test Results

Frequency Error vs. Voltage

Voltage (Volts)	LTE Band 7			
	Channel Bandwidth: 5 MHz			
	Low Channel		High Channel	
	Frequency (MHz)	Frequency Error (ppm)	Frequency (MHz)	Frequency Error (ppm)
3.85	2502.500002	0.0007	2567.500002	0.0008
3.6	2502.500003	0.0010	2567.500003	0.0011
4.4	2502.500001	0.0004	2567.500003	0.0012

Note: The applicant defined the normal working voltage of the battery is from 3.6 Vdc to 4.4 Vdc.

Frequency Error vs. Temperature

Temp. (°C)	LTE Band 7			
	Channel Bandwidth: 5 MHz			
	Low Channel		High Channel	
	Frequency (MHz)	Frequency Error (ppm)	Frequency (MHz)	Frequency Error (ppm)
-30	2502.500001	0.0004	2567.500004	0.0015
-20	2502.500002	0.0010	2567.500003	0.0011
-10	2502.500001	0.0005	2567.500004	0.0016
0	2502.500002	0.0006	2567.500002	0.0009
10	2502.500003	0.0014	2567.500004	0.0015
20	2502.499996	-0.0015	2567.499997	-0.0014
30	2502.499999	-0.0006	2567.499998	-0.0006
40	2502.499999	-0.0006	2567.499998	-0.0009
50	2502.499998	-0.0007	2567.499997	-0.0013
55	2502.499997	-0.0012	2567.499999	-0.0005

Frequency Error vs. Voltage

Voltage (Volts)	LTE Band 7			
	Channel Bandwidth: 10 MHz			
	Low Channel		High Channel	
	Frequency (MHz)	Frequency Error (ppm)	Frequency (MHz)	Frequency Error (ppm)
3.85	2505.000002	0.0007	2565.000003	0.0011
3.6	2505.000003	0.0013	2565.000003	0.0013
4.4	2505.000002	0.0006	2565.000004	0.0015

Note: The applicant defined the normal working voltage of the battery is from 3.6 Vdc to 4.4 Vdc.

Frequency Error vs. Temperature

Temp. (°C)	LTE Band 7			
	Channel Bandwidth: 10 MHz			
	Low Channel		High Channel	
	Frequency (MHz)	Frequency Error (ppm)	Frequency (MHz)	Frequency Error (ppm)
-30	2505.000002	0.0010	2565.000001	0.0004
-20	2505.000003	0.0013	2565.000004	0.0014
-10	2505.000002	0.0007	2565.000004	0.0014
0	2505.000003	0.0013	2565.000002	0.0009
10	2505.000002	0.0006	2565.000004	0.0014
20	2504.999996	-0.0015	2564.999999	-0.0004
30	2504.999999	-0.0006	2564.999999	-0.0005
40	2504.999998	-0.0010	2564.999999	-0.0004
50	2504.999997	-0.0011	2564.999998	-0.0007
55	2504.999997	-0.0010	2564.999999	-0.0005

Frequency Error vs. Voltage

Voltage (Volts)	LTE Band 7			
	Channel Bandwidth: 15 MHz			
	Low Channel		High Channel	
	Frequency (MHz)	Frequency Error (ppm)	Frequency (MHz)	Frequency Error (ppm)
3.85	2507.500002	0.0006	2562.500002	0.0009
3.6	2507.500002	0.0008	2562.500004	0.0014
4.4	2507.500003	0.0013	2562.500003	0.0012

Note: The applicant defined the normal working voltage of the battery is from 3.6 Vdc to 4.4 Vdc.

Frequency Error vs. Temperature

Temp. (°C)	LTE Band 7			
	Channel Bandwidth: 15 MHz			
	Low Channel		High Channel	
	Frequency (MHz)	Frequency Error (ppm)	Frequency (MHz)	Frequency Error (ppm)
-30	2507.500004	0.0015	2562.500003	0.0013
-20	2507.500004	0.0016	2562.500001	0.0004
-10	2507.500003	0.0010	2562.500003	0.0010
0	2507.500004	0.0016	2562.500002	0.0007
10	2507.500003	0.0012	2562.500001	0.0005
20	2507.499999	-0.0004	2562.499999	-0.0005
30	2507.499997	-0.0013	2562.499997	-0.0011
40	2507.499996	-0.0016	2562.499998	-0.0007
50	2507.499998	-0.0007	2562.499997	-0.0012
55	2507.499996	-0.0015	2562.499998	-0.0009

Frequency Error vs. Voltage

Voltage (Volts)	LTE Band 7			
	Channel Bandwidth: 20 MHz			
	Low Channel		High Channel	
	Frequency (MHz)	Frequency Error (ppm)	Frequency (MHz)	Frequency Error (ppm)
3.85	2510.000003	0.0010	2560.000003	0.0013
3.6	2510.000002	0.0009	2560.000003	0.0012
4.4	2510.000003	0.0013	2560.000003	0.0013

Note: The applicant defined the normal working voltage of the battery is from 3.6 Vdc to 4.4 Vdc.

Frequency Error vs. Temperature

Temp. (°C)	LTE Band 7			
	Channel Bandwidth: 20 MHz			
	Low Channel		High Channel	
	Frequency (MHz)	Frequency Error (ppm)	Frequency (MHz)	Frequency Error (ppm)
-30	2510.000002	0.0008	2560.000002	0.0007
-20	2510.000004	0.0015	2560.000003	0.0013
-10	2510.000002	0.0007	2560.000004	0.0014
0	2510.000003	0.0013	2560.000001	0.0004
10	2510.000002	0.0006	2560.000003	0.0012
20	2509.999998	-0.0008	2559.999999	-0.0005
30	2509.999997	-0.0011	2559.999997	-0.0013
40	2509.999998	-0.0009	2559.999999	-0.0005
50	2509.999998	-0.0008	2559.999998	-0.0007
55	2509.999998	-0.0009	2559.999998	-0.0007

Frequency Error vs. Voltage

Voltage (Volts)	LTE Band 38			
	Channel Bandwidth: 5 MHz			
	Low Channel		High Channel	
	Frequency (MHz)	Frequency Error (ppm)	Frequency (MHz)	Frequency Error (ppm)
3.85	2572.500003	0.0011	2617.500002	0.0008
3.6	2572.500004	0.0014	2617.500004	0.0015
4.4	2572.500003	0.0010	2617.500003	0.0011

Note: The applicant defined the normal working voltage of the battery is from 3.6 Vdc to 4.4 Vdc.

Frequency Error vs. Temperature

Temp. (°C)	LTE Band 38			
	Channel Bandwidth: 5 MHz			
	Low Channel		High Channel	
	Frequency (MHz)	Frequency Error (ppm)	Frequency (MHz)	Frequency Error (ppm)
-30	2572.500004	0.0015	2617.500004	0.0014
-20	2572.500003	0.0012	2617.500003	0.0013
-10	2572.500003	0.0011	2617.500004	0.0015
0	2572.500004	0.0014	2617.500002	0.0007
10	2572.500004	0.0015	2617.500003	0.0010
20	2572.499997	-0.0013	2617.499997	-0.0010
30	2572.499996	-0.0015	2617.499997	-0.0010
40	2572.499998	-0.0008	2617.499997	-0.0013
50	2572.499997	-0.0012	2617.499999	-0.0006
55	2572.499997	-0.0010	2617.499996	-0.0014

Frequency Error vs. Voltage

Voltage (Volts)	LTE Band 38			
	Channel Bandwidth: 10 MHz			
	Low Channel		High Channel	
	Frequency (MHz)	Frequency Error (ppm)	Frequency (MHz)	Frequency Error (ppm)
3.85	2575.000001	0.0005	2615.000003	0.0010
3.6	2575.000001	0.0004	2615.000004	0.0014
4.4	2575.000002	0.0009	2615.000001	0.0005

Note: The applicant defined the normal working voltage of the battery is from 3.6 Vdc to 4.4 Vdc.

Frequency Error vs. Temperature

Temp. (°C)	LTE Band 38			
	Channel Bandwidth: 10 MHz			
	Low Channel		High Channel	
	Frequency (MHz)	Frequency Error (ppm)	Frequency (MHz)	Frequency Error (ppm)
-30	2575.000004	0.0016	2615.000003	0.0010
-20	2575.000003	0.0011	2615.000003	0.0012
-10	2575.000004	0.0014	2615.000003	0.0013
0	2575.000003	0.0012	2615.000004	0.0015
10	2575.000002	0.0007	2615.000002	0.0007
20	2574.999999	-0.0005	2614.999998	-0.0007
30	2574.999997	-0.0011	2614.999999	-0.0006
40	2574.999997	-0.0013	2614.999998	-0.0009
50	2574.999998	-0.0008	2614.999997	-0.0011
55	2574.999998	-0.0009	2614.999997	-0.0010

Frequency Error vs. Voltage

Voltage (Volts)	LTE Band 38			
	Channel Bandwidth: 15 MHz			
	Low Channel		High Channel	
	Frequency (MHz)	Frequency Error (ppm)	Frequency (MHz)	Frequency Error (ppm)
3.85	2577.500004	0.0014	2612.500004	0.0015
3.6	2577.500003	0.0010	2612.500004	0.0014
4.4	2577.500001	0.0005	2612.500001	0.0004

Note: The applicant defined the normal working voltage of the battery is from 3.6 Vdc to 4.4 Vdc.

Frequency Error vs. Temperature

Temp. (°C)	LTE Band 38			
	Channel Bandwidth: 15 MHz			
	Low Channel		High Channel	
	Frequency (MHz)	Frequency Error (ppm)	Frequency (MHz)	Frequency Error (ppm)
-30	2577.500002	0.0006	2612.500003	0.0012
-20	2577.500003	0.0013	2612.500002	0.0007
-10	2577.500003	0.0011	2612.500002	0.0007
0	2577.500002	0.0009	2612.500004	0.0014
10	2577.500002	0.0006	2612.500004	0.0015
20	2577.499997	-0.0012	2612.499997	-0.0010
30	2577.499999	-0.0004	2612.499998	-0.0008
40	2577.499998	-0.0010	2612.499998	-0.0008
50	2577.499998	-0.0009	2612.499999	-0.0005
55	2577.499999	-0.0006	2612.499998	-0.0009

Frequency Error vs. Voltage

Voltage (Volts)	LTE Band 38			
	Channel Bandwidth: 20 MHz			
	Low Channel		High Channel	
	Frequency (MHz)	Frequency Error (ppm)	Frequency (MHz)	Frequency Error (ppm)
3.85	2580.000002	0.0009	2610.000002	0.0008
3.6	2580.000001	0.0005	2610.000002	0.0009
4.4	2580.000003	0.0013	2610.000000	0.0013

Note: The applicant defined the normal working voltage of the battery is from 3.6 Vdc to 4.4 Vdc.

Frequency Error vs. Temperature

Temp. (°C)	LTE Band 38			
	Channel Bandwidth: 20 MHz			
	Low Channel		High Channel	
	Frequency (MHz)	Frequency Error (ppm)	Frequency (MHz)	Frequency Error (ppm)
-30	2580.000001	0.0004	2610.000004	0.0014
-20	2580.000002	0.0009	2610.000001	0.0004
-10	2580.000001	0.0005	2610.000003	0.0011
0	2580.000002	0.0009	2610.000003	0.0012
10	2580.000004	0.0014	2610.000003	0.0010
20	2579.999996	-0.0016	2609.999999	-0.0005
30	2579.999998	-0.0009	2609.999999	-0.0006
40	2579.999998	-0.0009	2609.999998	-0.0008
50	2579.999998	-0.0007	2609.999998	-0.0007
55	2579.999998	-0.0009	2609.999996	-0.0015

Frequency Error vs. Voltage

Voltage (Volts)	LTE Band 41			
	Channel Bandwidth: 5 MHz			
	Low Channel		High Channel	
	Frequency (MHz)	Frequency Error (ppm)	Frequency (MHz)	Frequency Error (ppm)
3.85	2498.500004	0.0015	2687.500002	0.0006
3.6	2498.500002	0.0008	2687.500001	0.0004
4.4	2498.500002	0.0008	2687.500003	0.0010

Note: The applicant defined the normal working voltage of the battery is from 3.6 Vdc to 4.4 Vdc.

Frequency Error vs. Temperature

Temp. (°C)	LTE Band 41			
	Channel Bandwidth: 5 MHz			
	Low Channel		High Channel	
	Frequency (MHz)	Frequency Error (ppm)	Frequency (MHz)	Frequency Error (ppm)
-30	2498.500004	0.0015	2687.500001	0.0004
-20	2498.500003	0.0012	2687.500001	0.0005
-10	2498.500001	0.0006	2687.500002	0.0007
0	2498.500004	0.0014	2687.500002	0.0006
10	2498.500003	0.0014	2687.500002	0.0008
20	2498.499999	-0.0004	2687.499998	-0.0007
30	2498.499998	-0.0010	2687.499997	-0.0012
40	2498.499998	-0.0009	2687.499998	-0.0008
50	2498.499997	-0.0011	2687.499998	-0.0008
55	2498.499997	-0.0013	2687.499997	-0.0011

Frequency Error vs. Voltage

Voltage (Volts)	LTE Band 41			
	Channel Bandwidth: 10 MHz			
	Low Channel		High Channel	
	Frequency (MHz)	Frequency Error (ppm)	Frequency (MHz)	Frequency Error (ppm)
3.85	2501.000004	0.0015	2685.000003	0.0010
3.6	2501.000002	0.0008	2685.000004	0.0014
4.4	2501.000001	0.0004	2685.000002	0.0009

Note: The applicant defined the normal working voltage of the battery is from 3.6 Vdc to 4.4 Vdc.

Frequency Error vs. Temperature

Temp. (°C)	LTE Band 41			
	Channel Bandwidth: 10 MHz			
	Low Channel		High Channel	
	Frequency (MHz)	Frequency Error (ppm)	Frequency (MHz)	Frequency Error (ppm)
-30	2501.000001	0.0006	2685.000002	0.0009
-20	2501.000002	0.0009	2685.000003	0.0011
-10	2501.000003	0.0010	2685.000004	0.0015
0	2501.000003	0.0012	2685.000004	0.0013
10	2501.000003	0.0012	2685.000002	0.0006
20	2500.999999	-0.0006	2684.999998	-0.0008
30	2500.999996	-0.0016	2684.999997	-0.0013
40	2500.999998	-0.0009	2684.999997	-0.0013
50	2500.999998	-0.0008	2684.999997	-0.0011
55	2500.999997	-0.0012	2684.999996	-0.0014

Frequency Error vs. Voltage

Voltage (Volts)	LTE Band 41			
	Channel Bandwidth: 15 MHz			
	Low Channel		High Channel	
	Frequency (MHz)	Frequency Error (ppm)	Frequency (MHz)	Frequency Error (ppm)
3.85	2503.500003	0.0010	2682.500002	0.0006
3.6	2503.500003	0.0013	2682.500001	0.0005
4.4	2503.500001	0.0004	2682.500004	0.0015

Note: The applicant defined the normal working voltage of the battery is from 3.6 Vdc to 4.4 Vdc.

Frequency Error vs. Temperature

Temp. (°C)	LTE Band 41			
	Channel Bandwidth: 15 MHz			
	Low Channel		High Channel	
	Frequency (MHz)	Frequency Error (ppm)	Frequency (MHz)	Frequency Error (ppm)
-30	2503.500003	0.0010	2682.500002	0.0007
-20	2503.500001	0.0005	2682.500004	0.0013
-10	2503.500001	0.0006	2682.500004	0.0015
0	2503.500004	0.0014	2682.500003	0.0011
10	2503.500002	0.0006	2682.500003	0.0011
20	2503.499998	-0.0009	2682.499999	-0.0006
30	2503.499998	-0.0008	2682.499999	-0.0004
40	2503.499997	-0.0011	2682.499999	-0.0004
50	2503.499999	-0.0004	2682.499999	-0.0004
55	2503.499999	-0.0005	2682.499997	-0.0012

Frequency Error vs. Voltage

Voltage (Volts)	LTE Band 41			
	Channel Bandwidth: 20 MHz			
	Low Channel		High Channel	
	Frequency (MHz)	Frequency Error (ppm)	Frequency (MHz)	Frequency Error (ppm)
3.85	2506.000003	0.0012	2680.000002	0.0007
3.6	2506.000002	0.0008	2680.000004	0.0013
4.4	2506.000002	0.0010	2680.000003	0.0010

Note: The applicant defined the normal working voltage of the battery is from 3.6 Vdc to 4.4 Vdc.

Frequency Error vs. Temperature

Temp. (°C)	LTE Band 41			
	Channel Bandwidth: 20 MHz			
	Low Channel		High Channel	
	Frequency (MHz)	Frequency Error (ppm)	Frequency (MHz)	Frequency Error (ppm)
-30	2506.000002	0.0006	2680.000001	0.0004
-20	2506.000004	0.0015	2680.000002	0.0007
-10	2506.000003	0.0012	2680.000002	0.0009
0	2506.000001	0.0004	2680.000004	0.0014
10	2506.000002	0.0009	2680.000003	0.0010
20	2505.999997	-0.0011	2679.999998	-0.0007
30	2505.999997	-0.0014	2679.999996	-0.0015
40	2505.999999	-0.0004	2679.999998	-0.0006
50	2505.999996	-0.0015	2679.999998	-0.0009
55	2505.999996	-0.0016	2679.999998	-0.0006

4.4 Occupied Bandwidth Measurement

4.4.1 Limits of Occupied Bandwidth Measurement

The width of a frequency band such that, below the lower and above the upper frequency limits, the mean powers emitted are each equal to a specified percentage 0.5 % of the total mean power of a given emission.

4.4.2 Test Procedure

- The conducted occupied bandwidth used the power splitter via EUT RF power connector between simulation base station and spectrum analyzer.
- Use OBW measurement function of Spectrum analyzer to measure 99 % occupied bandwidth.

4.4.3 Test Setup

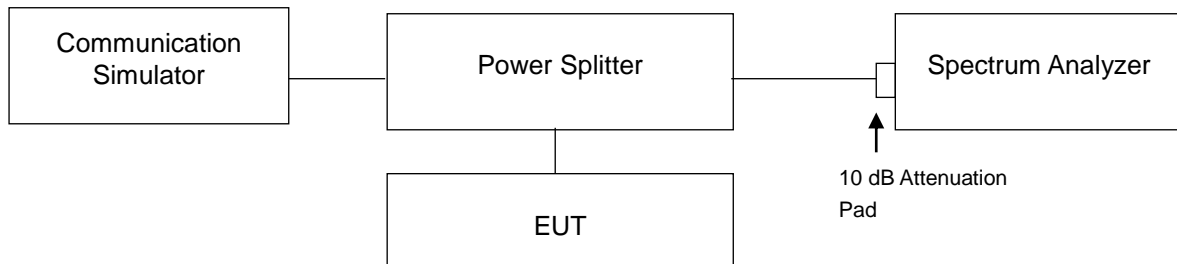

4.4.4 Test Results

<99 % Occupied Bandwidth>

LTE Band 7									
Channel Bandwidth: 5 MHz					Channel Bandwidth: 10 MHz				
Channel	Frequency (MHz)	99 % Occupied Bandwidth (MHz)			Channel	Frequency (MHz)	99 % Occupied Bandwidth (MHz)		
		QPSK	16QAM	64QAM			QPSK	16QAM	64QAM
20775	2502.5	4.4932	4.4923	4.5034	20800	2505.0	8.9671	8.9693	8.9721
21100	2535.0	4.4898	4.4922	4.4986	21100	2535.0	8.9645	8.9675	8.9712
21425	2567.5	4.4927	4.4956	4.5044	21400	2565.0	8.9681	8.9661	8.9745

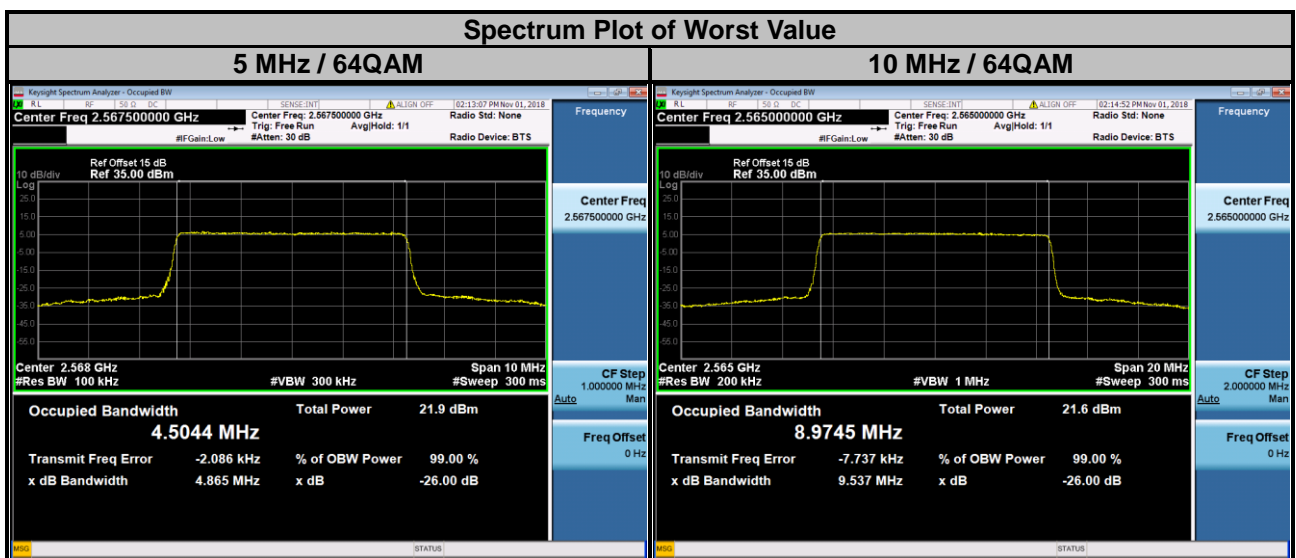

LTE Band 7

Channel Bandwidth: 15 MHz					Channel Bandwidth: 20 MHz				
Channel	Frequency (MHz)	99 % Occupied Bandwidth (MHz)			Channel	Frequency (MHz)	99 % Occupied Bandwidth (MHz)		
		QPSK	16QAM	64QAM			QPSK	16QAM	64QAM
20825	2507.5	13.454	13.439	13.434	20850	2510.0	17.925	17.946	17.935
21100	2535.0	13.443	13.436	13.432	21100	2535.0	17.901	17.928	17.923
21375	2562.5	13.447	13.435	13.428	21350	2560.0	17.909	17.930	17.931

Spectrum Plot of Worst Value

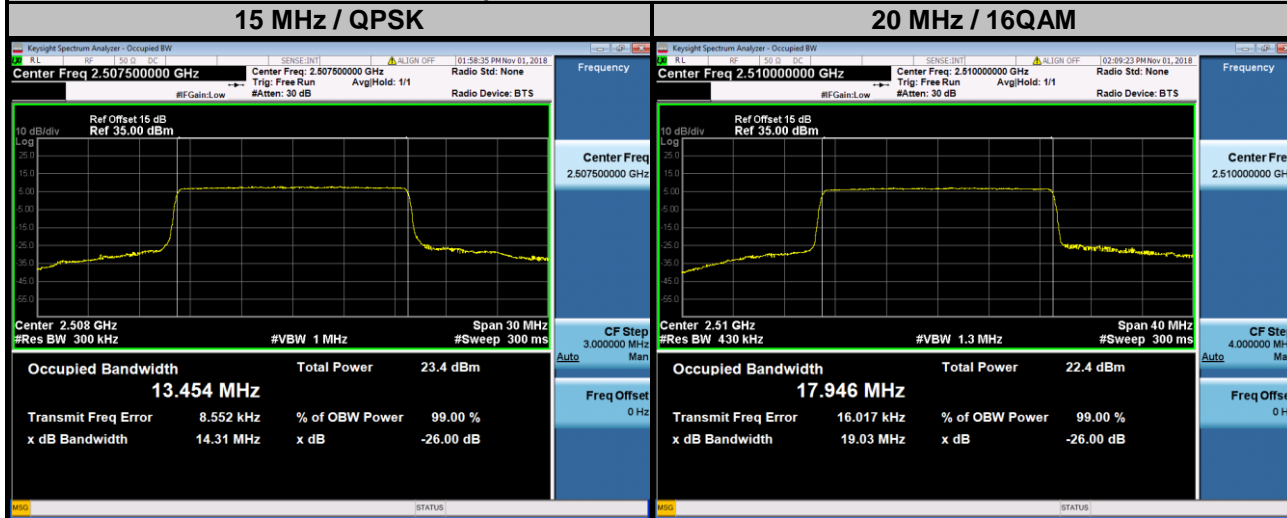

LTE Band 38

Channel Bandwidth: 5 MHz					Channel Bandwidth: 10 MHz				
Channel	Frequency (MHz)	99 % Occupied Bandwidth (MHz)			Channel	Frequency (MHz)	99 % Occupied Bandwidth (MHz)		
		QPSK	16QAM	64QAM			QPSK	16QAM	64QAM
37775	2572.5	4.4915	4.4890	4.5001	37800	2575.0	8.9577	8.9627	8.9586
38000	2595.0	4.4903	4.4891	4.4984	38000	2595.0	8.9550	8.9705	8.9577
38225	2617.5	4.4921	4.4909	4.5011	38200	2615.0	8.9543	8.9672	8.9582

Spectrum Plot of Worst Value

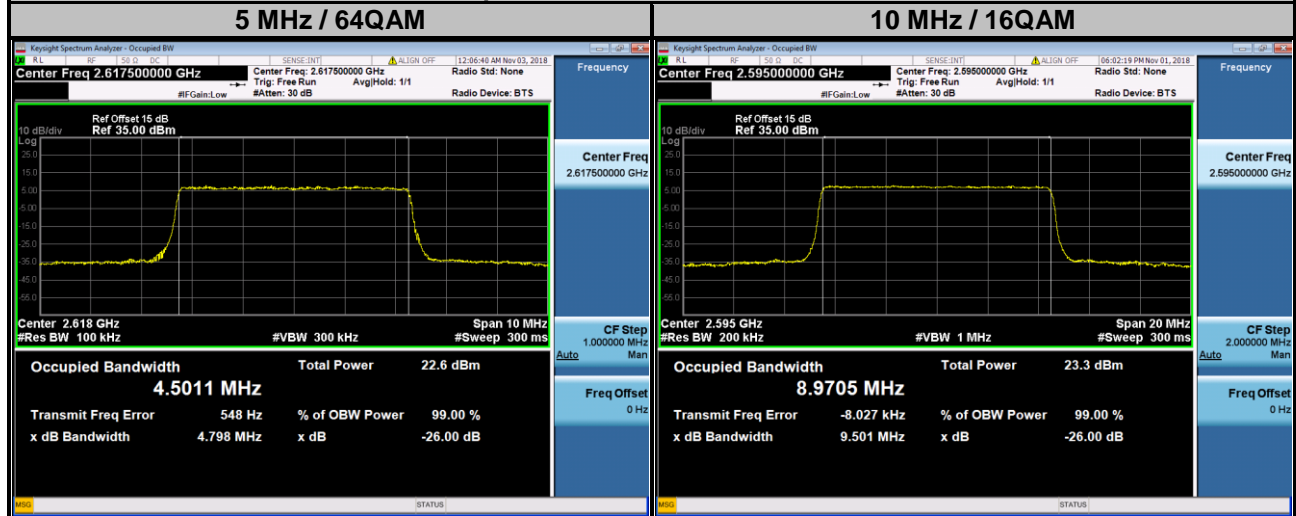

LTE Band 38

Channel Bandwidth: 15 MHz					Channel Bandwidth: 20 MHz				
Channel	Frequency (MHz)	99 % Occupied Bandwidth (MHz)			Channel	Frequency (MHz)	99 % Occupied Bandwidth (MHz)		
		QPSK	16QAM	64QAM			QPSK	16QAM	64QAM
37825	2577.5	13.443	13.436	13.431	37850	2580.0	17.911	17.910	17.925
38000	2595.0	13.446	13.432	13.431	38000	2595.0	17.918	17.907	17.930
38175	2612.5	13.443	13.440	13.443	38150	2610.0	17.917	17.909	17.936

Spectrum Plot of Worst Value

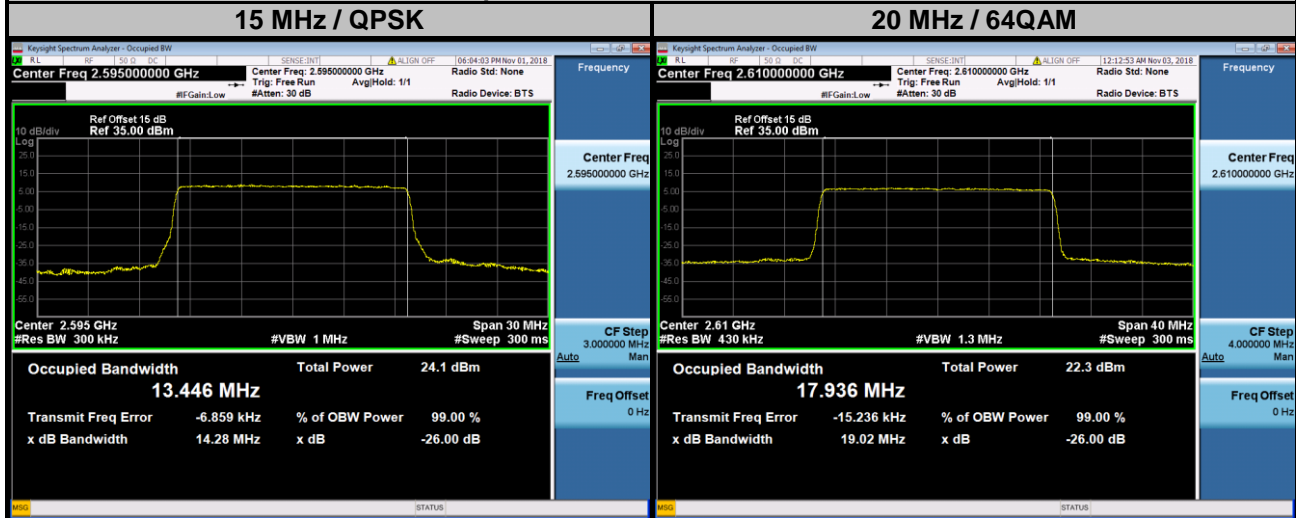

LTE Band 41

Channel Bandwidth: 5 MHz					Channel Bandwidth: 10 MHz				
Channel	Frequency (MHz)	99 % Occupied Bandwidth (MHz)			Channel	Frequency (MHz)	99 % Occupied Bandwidth (MHz)		
		QPSK	16QAM	64QAM			QPSK	16QAM	64QAM
39675	2498.5	4.4911	4.4886	4.4998	39700	2501.0	8.9511	8.9632	8.9655
40620	2593.0	4.4888	4.4904	4.5030	40620	2593.0	8.9553	8.9631	8.9657
41565	2687.5	4.4910	4.4934	4.5049	41540	2685.0	8.9556	8.9641	8.9656

Spectrum Plot of Worst Value



LTE Band 41

Channel Bandwidth: 15 MHz					Channel Bandwidth: 20 MHz				
Channel	Frequency (MHz)	99 % Occupied Bandwidth (MHz)			Channel	Frequency (MHz)	99 % Occupied Bandwidth (MHz)		
		QPSK	16QAM	64QAM			QPSK	16QAM	64QAM
39725	2503.5	13.436	13.427	13.420	39750	2506.0	17.897	17.894	17.919
40620	2593.0	13.439	13.433	13.432	40620	2593.0	17.907	17.901	17.924
41515	2682.5	13.442	13.425	13.431	41490	2680.0	17.864	17.862	17.872

Spectrum Plot of Worst Value

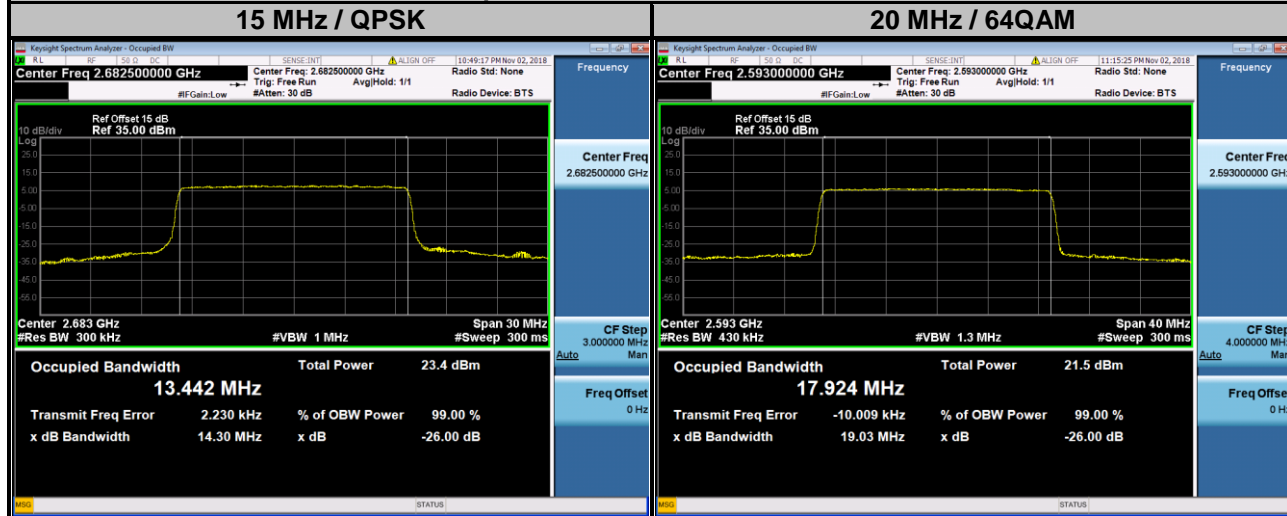

<26 dB Bandwidth>

LTE Band 7									
Channel Bandwidth: 5 MHz					Channel Bandwidth: 10 MHz				
Channel	Frequency (MHz)	26 dB Bandwidth (MHz)			Channel	Frequency (MHz)	26 dB Bandwidth (MHz)		
		QPSK	16QAM	64QAM			QPSK	16QAM	64QAM
20775	2502.5	4.829	4.792	4.835	20800	2505.0	9.528	9.513	9.523
21100	2535.0	4.823	4.809	4.831	21100	2535.0	9.514	9.516	9.531
21425	2567.5	4.828	4.810	4.865	21400	2565.0	9.525	9.513	9.537

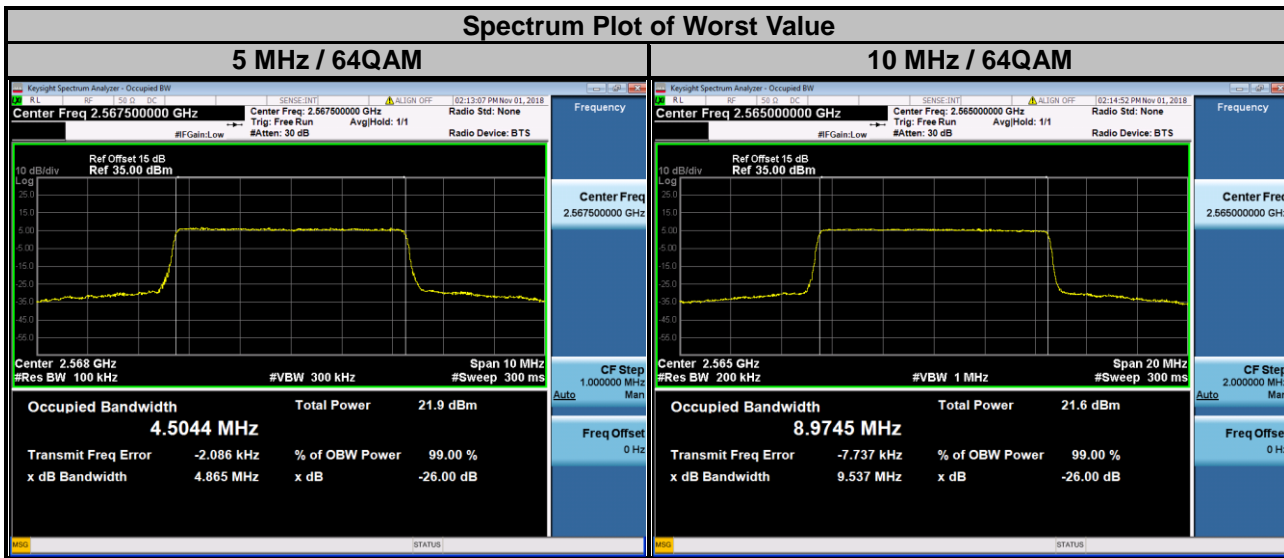

LTE Band 7									
Channel Bandwidth: 15 MHz					Channel Bandwidth: 20 MHz				
Channel	Frequency (MHz)	26 dB Bandwidth (MHz)			Channel	Frequency (MHz)	26 dB Bandwidth (MHz)		
		QPSK	16QAM	64QAM			QPSK	16QAM	64QAM
20825	2507.5	14.31	14.24	14.23	20850	2510.0	19.08	19.04	19.03
21100	2535.0	14.26	14.25	14.24	21100	2535.0	19.04	19.03	19.03
21375	2562.5	14.27	14.24	14.24	21350	2560.0	19.06	19.03	19.03

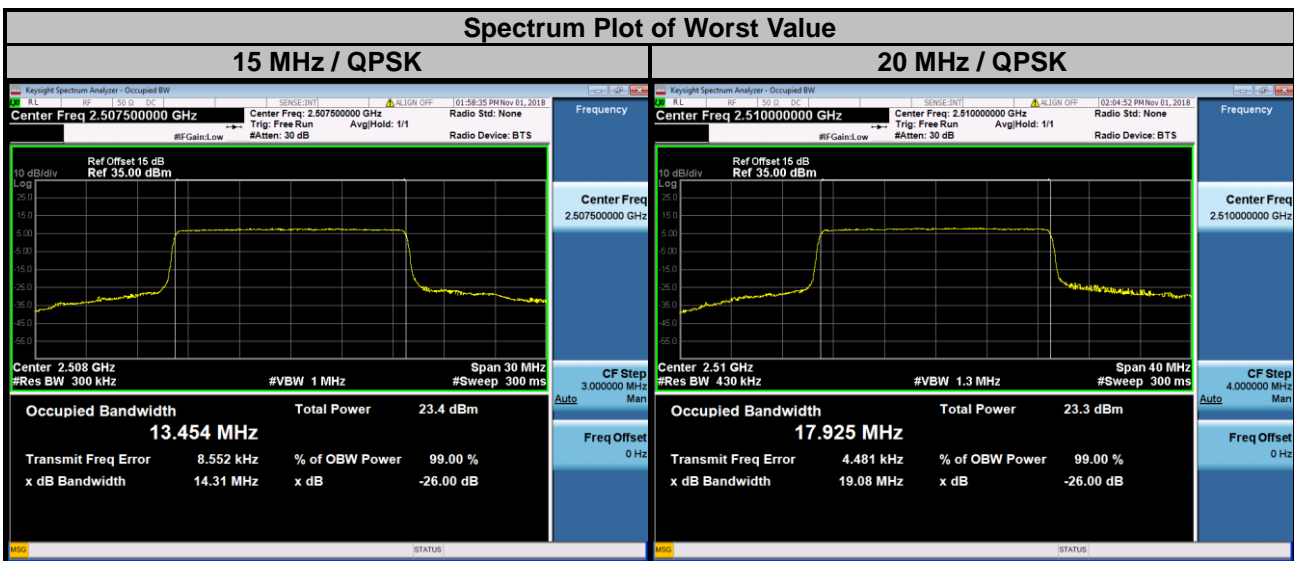

LTE Band 38									
Channel Bandwidth: 5 MHz					Channel Bandwidth: 10 MHz				
Channel	Frequency (MHz)	26 dB Bandwidth (MHz)			Channel	Frequency (MHz)	26 dB Bandwidth (MHz)		
		QPSK	16QAM	64QAM			QPSK	16QAM	64QAM
37775	2572.5	4.815	4.783	4.809	37800	2575.0	9.510	9.505	9.509
38000	2595.0	4.830	4.793	4.786	38000	2595.0	9.503	9.501	9.543
38225	2617.5	4.815	4.798	4.798	38200	2615.0	9.500	9.495	9.540

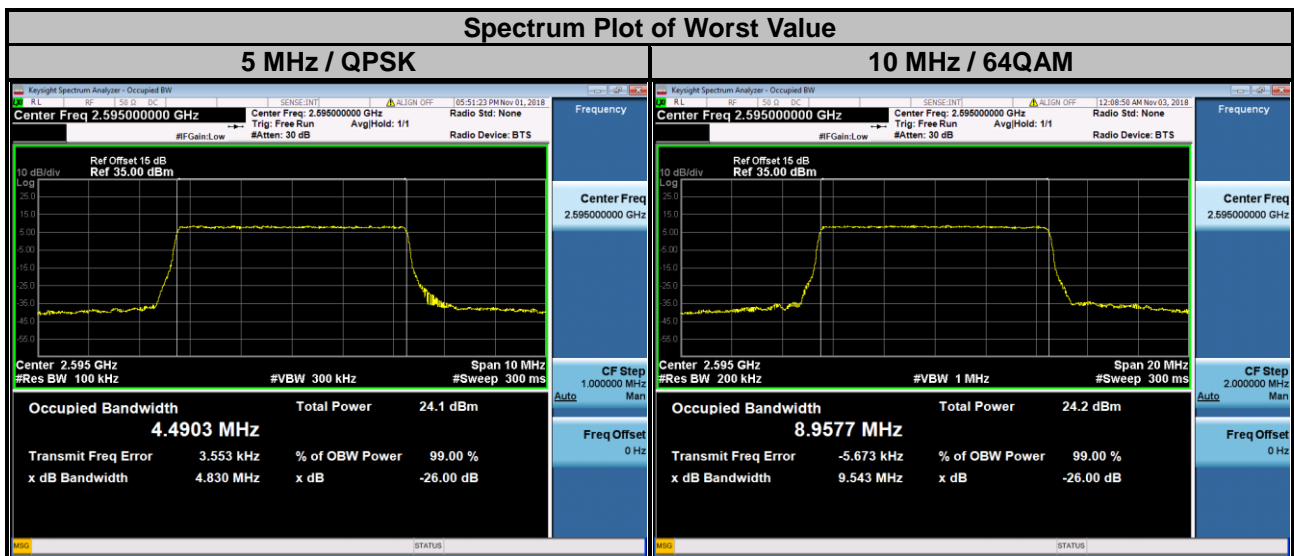

LTE Band 38									
Channel Bandwidth: 15 MHz					Channel Bandwidth: 20 MHz				
Channel	Frequency (MHz)	26 dB Bandwidth (MHz)			Channel	Frequency (MHz)	26 dB Bandwidth (MHz)		
		QPSK	16QAM	64QAM			QPSK	16QAM	64QAM
37825	2577.5	14.28	14.22	14.25	37850	2580.0	19.06	19.02	19.02
38000	2595.0	14.28	14.22	14.25	38000	2595.0	19.05	19.01	19.04
38175	2612.5	14.28	14.25	14.24	38150	2610.0	19.04	19.02	19.02

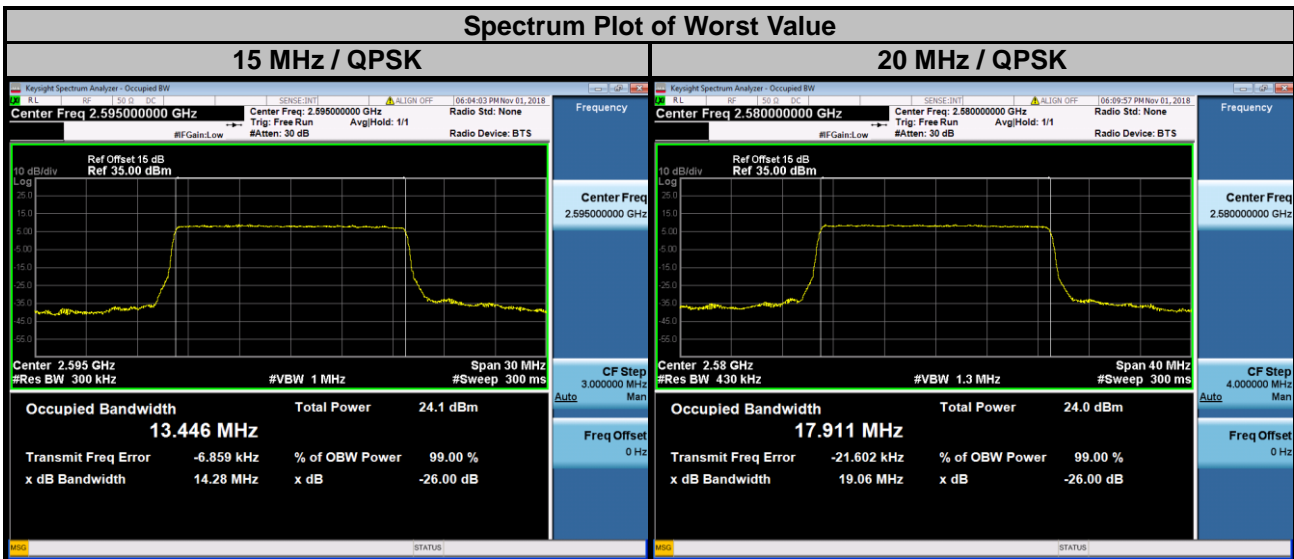

LTE Band 41									
Channel Bandwidth: 5 MHz					Channel Bandwidth: 10 MHz				
Channel	Frequency (MHz)	26 dB Bandwidth (MHz)			Channel	Frequency (MHz)	26 dB Bandwidth (MHz)		
		QPSK	16QAM	64QAM			QPSK	16QAM	64QAM
39675	2498.5	4.806	4.802	4.807	39700	2501.0	9.496	9.507	9.493
40620	2593.0	4.817	4.802	4.803	40620	2593.0	9.492	9.507	9.511
41565	2687.5	4.820	4.805	4.814	41540	2685.0	9.502	9.509	9.510

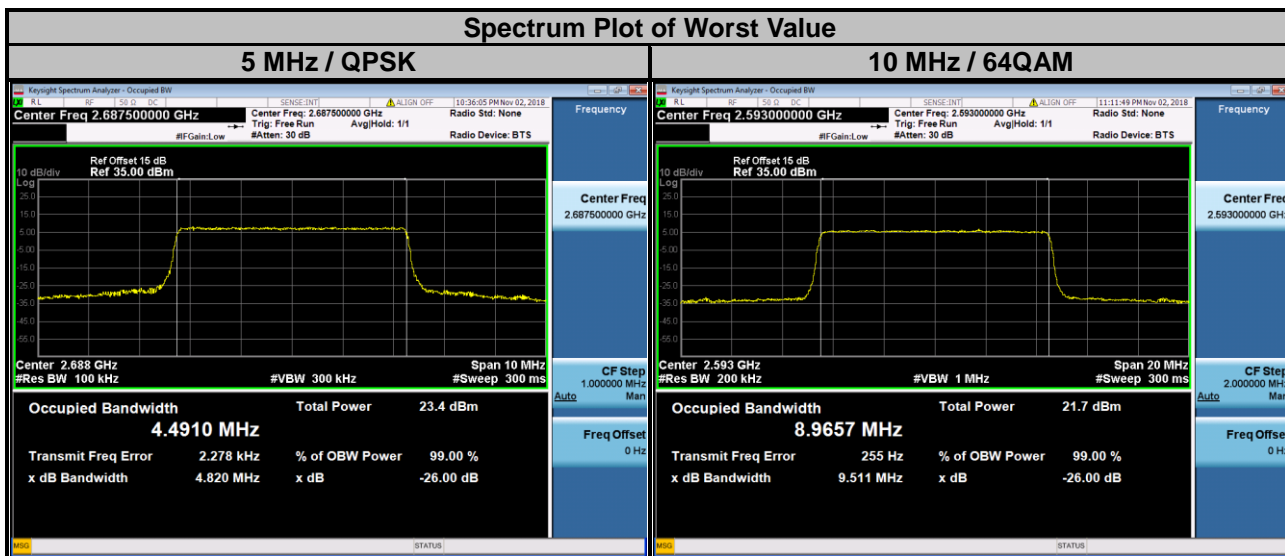

LTE Band 41									
Channel Bandwidth: 15 MHz					Channel Bandwidth: 20 MHz				
Channel	Frequency (MHz)	26 dB Bandwidth (MHz)			Channel	Frequency (MHz)	26 dB Bandwidth (MHz)		
		QPSK	16QAM	64QAM			QPSK	16QAM	64QAM
39725	2503.5	14.26	14.21	14.24	39750	2506.0	19.04	19.01	19.02
40620	2593.0	14.27	14.23	14.24	40620	2593.0	19.03	19.01	19.03
41515	2682.5	14.30	14.25	14.25	41490	2680.0	19.01	18.99	19.00

