



FCC RADIO TEST REPORT

FCC ID : A4RG013C
Equipment : Smartphone
Model name : G013C
Applicant : Google LLC
1600 Amphitheatre Parkway,
Mountain View, California, 94043 USA
Standard : FCC Part 15 Subpart E §15.407

The product completed on Jun. 26, 2018. We, SPORTON INTERNATIONAL INC., would like to declare that the tested sample has been evaluated in accordance with the test procedures and has been in compliance with the applicable technical standards.

The report must not be used by the client to claim product certification, approval, or endorsement by TAF or any agency of government.

The test results in this report apply exclusively to the tested model / sample. Without written approval of SPORTON INTERTIONAL INC. EMC & Wireless Communications Laboratory, the test report shall not be reproduced except in full.

Approved by: Jones Tsai

SPORTON INTERTIONAL INC. EMC & Wireless Communications Laboratory

No. 52, Huaya 1st Rd., Guishan Dist., Taoyuan City, Taiwan (R.O.C.)



Table of Contents

History of this test report.....	3
Summary of Test Result.....	4
1 General Description	5
1.1 Product Feature of Equipment Under Test.....	5
1.3 Product Specification of Equipment Under Test.....	6
1.4 Modification of EUT	6
1.5 Testing Location	7
1.6 Applicable Standards.....	7
2 Test Configuration of Equipment Under Test	8
2.1 Carrier Frequency and Channel	8
2.2 Test Mode.....	9
2.3 Connection Diagram of Test System.....	10
2.4 Support Unit used in test configuration and system	11
2.5 EUT Operation Test Setup	12
2.6 Measurement Results Explanation Example.....	12
3 Test Result	13
3.1 6dB and 26dB and 99% Occupied Bandwidth Measurement	13
3.2 Maximum Conducted Output Power Measurement	16
3.3 Power Spectral Density Measurement	17
3.4 Unwanted Emissions Measurement.....	20
3.5 AC Conducted Emission Measurement.....	26
3.6 Automatically Discontinue Transmission	28
3.7 Antenna Requirements.....	29
4 List of Measuring Equipment.....	30
5 Uncertainty of Evaluation.....	32
Appendix A. Conducted Test Results	
Appendix B. AC Conducted Emission Test Result	
Appendix C. Radiated Spurious Emission	
Appendix D. Radiated Spurious Emission Plots	
Appendix E. Duty Cycle Plots	



Summary of Test Result

Report Clause	Ref Std. Clause	Test Items	Result (PASS/FAIL)	Remark
3.1	15.403 (i)	6dB & 26dB Bandwidth	Pass	-
3.1	2.1049	99% Occupied Bandwidth	Reporting only	-
3.2	15.407 (a)	Maximum Conducted Output Power	Pass	-
3.3	15.407 (a)	Power Spectral Density	Pass	-
3.4	15.407(b)	Unwanted Emissions	Pass	Under limit 3.19 dB at 11490.000 MHz
3.5	15.207	AC Conducted Emission	Pass	Under limit 7.21 dB at 13.560 MHz
3.6	15.407 (c)	Automatically Discontinue Transmission	Pass	-
3.7	15.203 & 15.407 (a)	Antenna Requirement	Pass	-

Reviewed by: Joseph Lin

Report Producer: Natasha Hsieh



1 General Description

1.1 Product Feature of Equipment Under Test

Product Feature	
Equipment	Smartphone
Model Name	G013C
FCC ID	A4RG013C
EUT supports Radios application	CDMA/EV-DO/GSM/EGPRS/WCDMA/HSPA/LTE/NFC/ GNSS/WPC WLAN 11b/g/n HT20/VHT20 WLAN 11a/n HT20/HT40 WLAN 11ac VHT20/VHT40/VHT80 Bluetooth BR/EDR/LE
EUT Stage	Identical Prototype

Remark: The above EUT's information was declared by manufacturer. Please refer to the specifications or user's manual for more detailed description.

EUT Information List	
No.	S/N
#1	85KY00936
#2	85LY00985
#3	85LY009BE



1.3 Product Specification of Equipment Under Test

Standards-related Product Specification										
Tx/Rx Channel Frequency Range	5745 MHz ~ 5825 MHz									
Maximum Output Power	<p><5745 MHz ~ 5825 MHz></p> <p><Ant. 1> 802.11a : 17.15 dBm / 0.0519 W 802.11n HT20 : 17.31 dBm / 0.0538 W 802.11n HT40 : 17.72 dBm / 0.0592 W 802.11ac VHT20: 17.24 dBm / 0.0530 W 802.11ac VHT40: 17.70 dBm / 0.0589 W 802.11ac VHT80: 17.34 dBm / 0.0542 W</p> <p><Ant. 2> 802.11a : 17.65 dBm / 0.0582 W 802.11n HT20 : 17.51 dBm / 0.0564 W 802.11n HT40 : 17.80 dBm / 0.0603 W 802.11ac VHT20: 17.49 dBm / 0.0561 W 802.11ac VHT40: 17.78 dBm / 0.0600 W 802.11ac VHT80: 17.49 dBm / 0.0561 W</p> <p>MIMO <Ant. 1 + 2> 802.11a : 20.60 dBm / 0.1148 W 802.11n HT20 : 20.45 dBm / 0.1109 W 802.11n HT40 : 20.83 dBm / 0.1211 W 802.11ac VHT20: 20.43 dBm / 0.1104 W 802.11ac VHT40: 20.78 dBm / 0.1197 W 802.11ac VHT80: 20.44 dBm / 0.1107 W</p>									
99% Occupied Bandwidth	<p><Ant. 1> 802.11a : 17.10 MHz 802.11n HT20 : 18.15 MHz 802.11n HT40 : 37.10 MHz 802.11ac VHT80 : 76.20 MHz</p> <p><Ant. 2> 802.11a : 30.75 MHz 802.11n HT20 : 34.50 MHz 802.11n HT40 : 69.80 MHz 802.11ac VHT80 : 95.88 MHz</p>									
Type of Modulation	802.11a/n : OFDM (BPSK / QPSK / 16QAM / 64QAM) 802.11ac : OFDM (BPSK / QPSK / 16QAM / 64QAM / 256QAM)									
Antenna Type / Gain	<p><Ant. 1> : slot Antenna with gain -0.30 dBi <Ant. 2> : integrated monopole Antenna with gain -0.40 dBi</p>									
Antenna Function Description	<table border="1"> <thead> <tr> <th></th> <th>Ant. 1</th> <th>Ant. 2</th> </tr> </thead> <tbody> <tr> <td>802.11 a/n/ac</td> <td>V</td> <td>V</td> </tr> <tr> <td>802.11 n/ac MIMO</td> <td>V</td> <td>V</td> </tr> </tbody> </table>		Ant. 1	Ant. 2	802.11 a/n/ac	V	V	802.11 n/ac MIMO	V	V
	Ant. 1	Ant. 2								
802.11 a/n/ac	V	V								
802.11 n/ac MIMO	V	V								

1.4 Modification of EUT

No modifications are made to the EUT during all test items.



1.5 Testing Location

Sporton Lab is accredited to ISO 17025 by Taiwan Accreditation Foundation (TAF code : 1190) and the FCC designation No. TW1190 and TW0007 under the FCC 2.948(e) by Mutual Recognition Agreement (MRA) in FCC Test.

Test Site	SPORTON INTERNATIONAL INC.	
Test Site Location	No.52, Huaya 1st Rd., Guishan Dist., Taoyuan City, Taiwan (R.O.C.) TEL: +886-3-327-3456 FAX: +886-3-328-4978	
Test Site No.	Sporton Site No.	
	TH05-HY	CO05-HY

Note: The test site complies with ANSI C63.4 2014 requirement.

Test Site	SPORTON INTERNATIONAL INC.	
Test Site Location	No.58, Aly. 75, Ln. 564, Wenhua 3rd, Rd., Guishan Dist., Taoyuan City, Taiwan (R.O.C.) TEL: +886-3-327-0868 FAX: +886-3-327-0855	
Test Site No.	Sporton Site No.	
	03CH15-HY	

Note: The test site complies with ANSI C63.4 2014 requirement.

1.6 Applicable Standards

According to the specifications of the manufacturer, the EUT must comply with the requirements of the following standards:

- ♦ FCC Part 15 Subpart E
- ♦ FCC KDB 789033 D02 General UNII Test Procedures New Rules v02r01.
- ♦ FCC KDB 662911 D01 Multiple Transmitter Output v02r01.
- ♦ ANSI C63.10-2013

Remark:

1. All test items were verified and recorded according to the standards and without any deviation during the test.
2. This EUT has also been tested and complied with the requirements of FCC Part 15, Subpart B, recorded in a separate test report.



2 Test Configuration of Equipment Under Test

- a. The EUT has been associated with peripherals and configuration operated in a manner tended to maximize its emission characteristics in a typical application. Frequency range investigated: conduction emission (150 kHz to 30 MHz), radiation emission (9 kHz to the 10th harmonic of the highest fundamental frequency or to 40 GHz, whichever is lower). For radiated measurement, pre-scanned in three orthogonal panels, X, Y, Z. The worst cases (Y plane) were recorded in this report.
- b. AC power line Conducted Emission was tested under maximum output power.

2.1 Carrier Frequency and Channel

Frequency Band	Channel	Freq. (MHz)	Channel	Freq. (MHz)
5725-5850 MHz Band 4 (U-NII-3)	149	5745	157	5785
	151*	5755	159*	5795
	153	5765	161	5805
	155 [#]	5775	165	5825

Note:

1. The above Frequency and Channel in "*" were 802.11n HT40 and 802.11ac VHT40.
2. The above Frequency and Channel in "[#]" were 802.11ac VHT80.



2.2 Test Mode

Final test modes are considering the modulation and worse data rates as below table.

MIMO Mode

Modulation	Data Rate
802.11a	6 Mbps
802.11n HT20	MCS0
802.11n HT40	MCS0
802.11ac VHT20 (Covered by HT20)	MCS0
802.11ac VHT40 (Covered by HT40)	MCS0
802.11ac VHT80	MCS0

Test Cases	
AC Conducted Emission	Mode 1 : GSM1900 Idle + WLAN Link (5GHz) + Bluetooth Link + NFC Read On + USB cable (Type C) (Charging from Adapter 1)
Remark: For Radiated Test Cases, the tests were performed with Adapter 1.	

Ch. #		Band IV : 5725-5850 MHz			
		802.11a	802.11n HT20	802.11n HT40	802.11ac VHT80
L	Low	149	149	151	-
M	Middle	157	157	-	155
H	High	165	165	159	-

2.3 Connection Diagram of Test System

<WLAN Tx Mode>

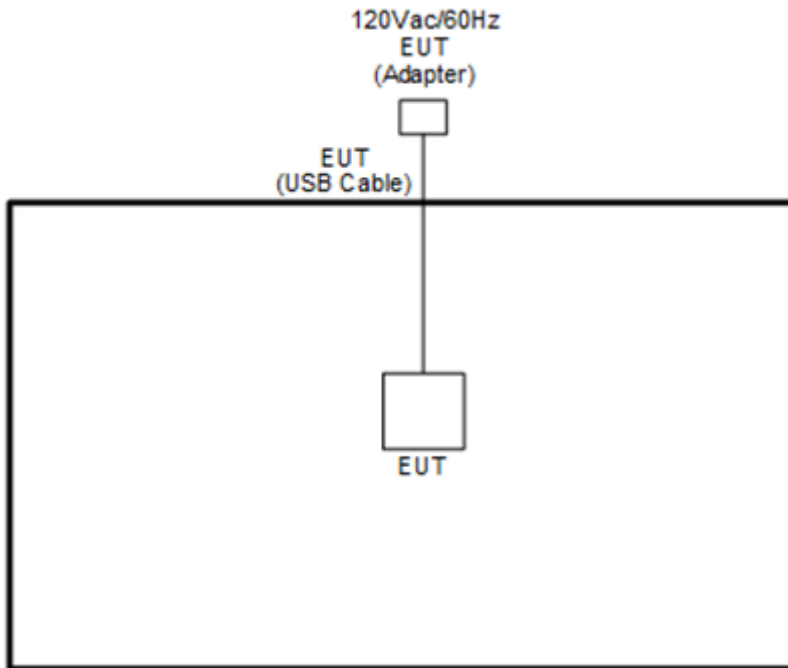

< WLAN Tx with WPC Charging Mode>

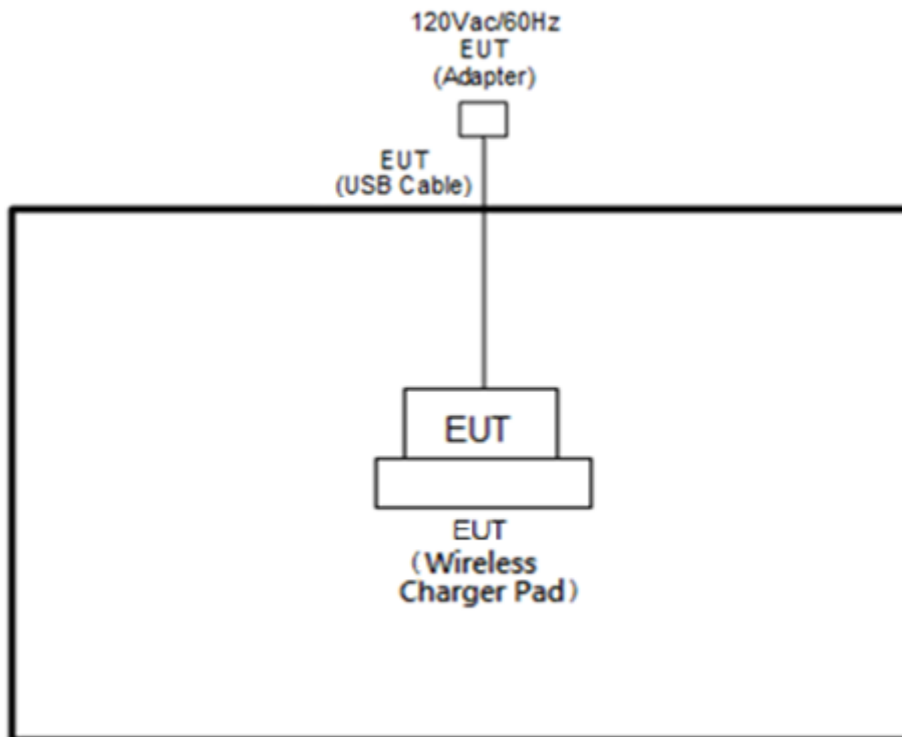

<AC Conducted Emissions Mode>

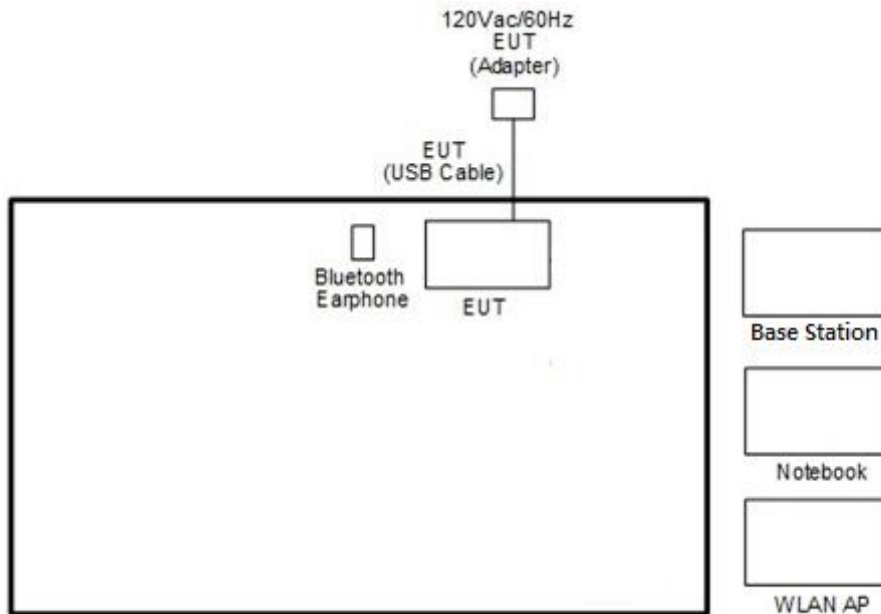

2.4 Support Unit used in test configuration and system

Item	Equipment	Trade Name	Model Name	FCC ID	Data Cable	Power Cord
1.	System Simulator	Anritsu	MT8820C	N/A	N/A	Unshielded, 1.8 m
2.	Bluetooth Earphone	Sony Ericsson	MW600	PY7DDA-2029	N/A	N/A
3.	WLAN AP	ASUS	RT-AC66U	MSQ-RTAC66U	N/A	Unshielded, 1.8 m
4.	Notebook	DELL	Latitude E6320	FCC DoC/ Contains FCC ID: QDS-BRCM1054	N/A	AC I/P: Unshielded, 1.2 m DC O/P: Shielded, 1.8 m



2.5 EUT Operation Test Setup

The RF test items, utility “QRCT” was installed in Notebook which was programmed in order to make the EUT get into the engineering modes to provide channel selection, power level, data rate and the application type and for continuous transmitting signals.

2.6 Measurement Results Explanation Example

For all conducted test items:

The offset level is set in the spectrum analyzer to compensate the RF cable loss and attenuator factor between EUT conducted output port and spectrum analyzer. With the offset compensation, the spectrum analyzer reading level is exactly the EUT RF output level.

Example :

The spectrum analyzer offset is derived from RF cable loss and attenuator factor.

Offset = RF cable loss + attenuator factor.

Following shows an offset computation example with cable loss 4.2 dB and 10dB attenuator.

$$\begin{aligned} \text{Offset(dB)} &= \text{RF cable loss(dB)} + \text{attenuator factor(dB)}. \\ &= 4.2 + 10 = 14.2 \text{ (dB)} \end{aligned}$$

3 Test Result

3.1 6dB and 26dB and 99% Occupied Bandwidth Measurement

3.1.1 Description of 6dB and 26dB and 99% Occupied Bandwidth

The minimum 6 dB bandwidth shall be at least 500 kHz.

26dB and 99% Occupied bandwidth are reporting only.

3.1.2 Measuring Instruments

See list of measuring equipment of this test report.

3.1.3 Test Procedures

1. The testing follows FCC KDB 789033 D02 General UNII Test Procedures New Rules v02r01. Section C) Emission bandwidth for the band 5.725-5.85GHz
2. Set RBW = 100kHz.
3. Set the VBW $\geq 3 \times$ RBW.
4. Detector = Peak.
5. Trace mode = max hold
6. Measure the maximum width of the emission that is 6 dB down from the peak of the emission.
7. Measure and record the results in the test report.

3.1.4 Test Setup

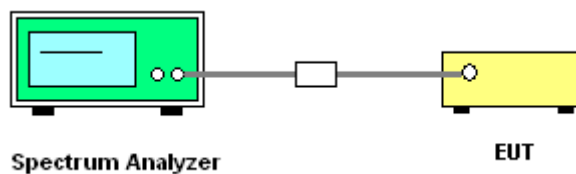

3.1.5 Test Result of 6dB Bandwidth

Please refer to Appendix A.

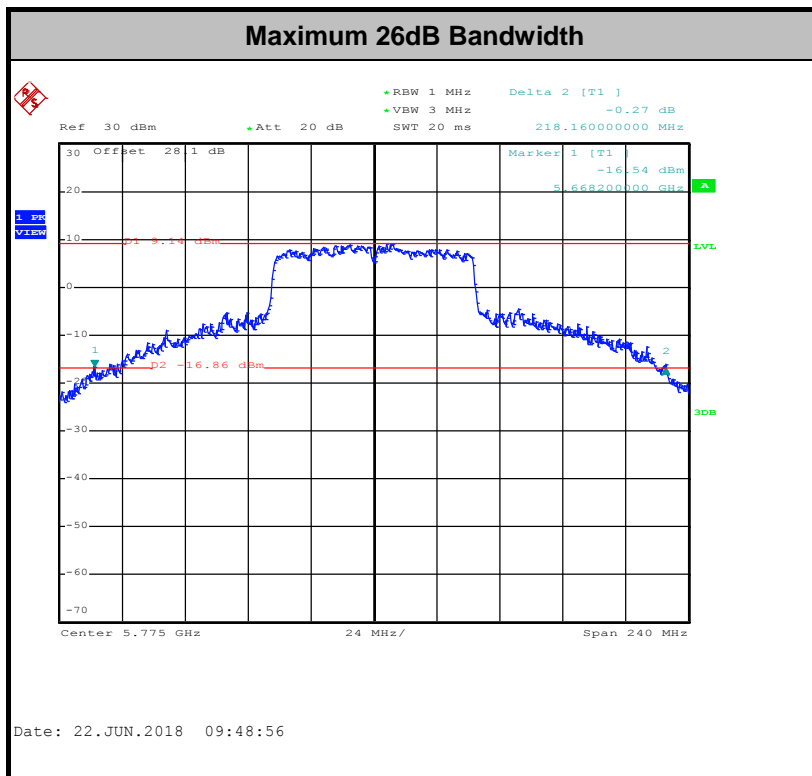
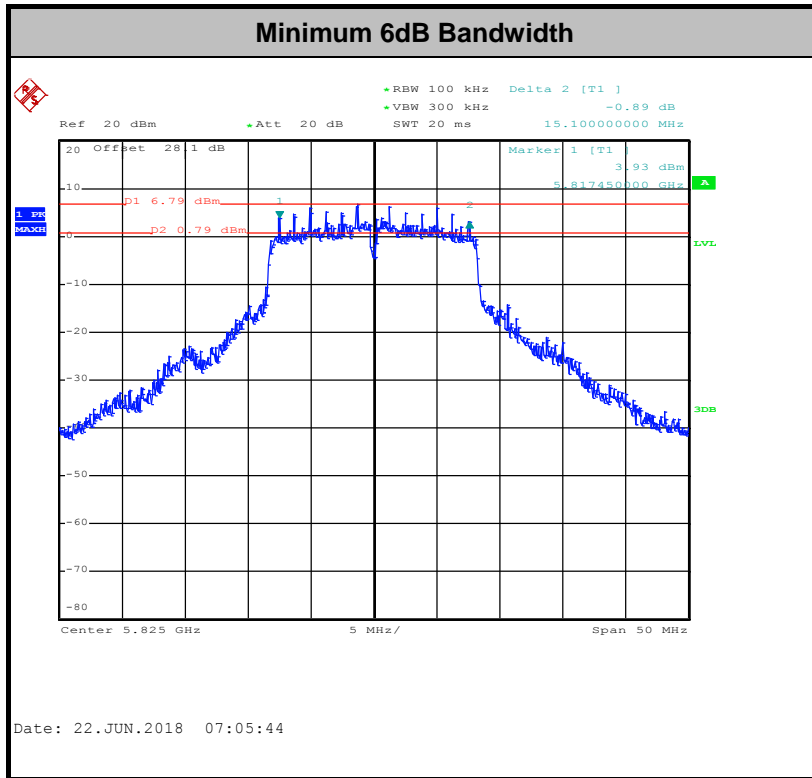

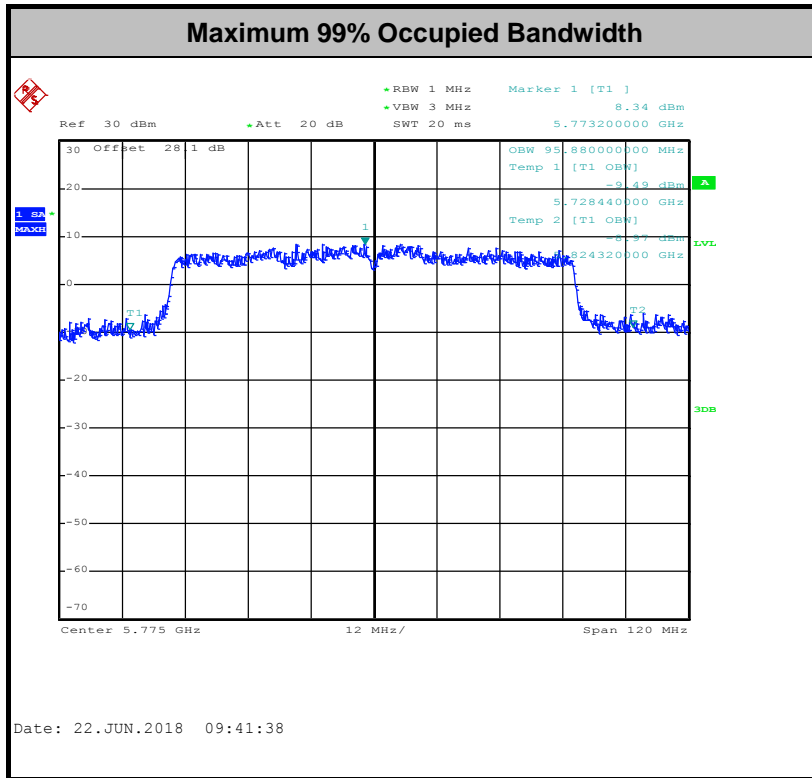

Note: The occupied channel bandwidth is maintained within the band of operation for all of the modulations.

3.2 Maximum Conducted Output Power Measurement

3.2.1 Limit of Maximum Conducted Output Power

For the band 5.725–5.85 GHz, the maximum conducted output power over the frequency band of operation shall not exceed 1 W.

If transmitting antennas of directional gain greater than 6 dBi are used, the peak output power shall be reduced by the amount in dB that the directional gain of the antenna exceeds 6 dBi.

3.2.2 Measuring Instruments

See list of measuring equipment of this test report.

3.2.3 Test Procedures

The testing follows Method PM of FCC KDB 789033 D02 General UNII Test Procedures New Rules v02r01.

Method PM (Measurement using an RF average power meter):

1. Measurement is performed using a wideband RF power meter.
2. The EUT is configured to transmit continuously with a consistent duty cycle at its maximum power control level.
3. Measure the average power of the transmitter, and the average power is corrected with duty factor, $10 \log(1/x)$, where x is the duty cycle.

3.2.4 Test Setup

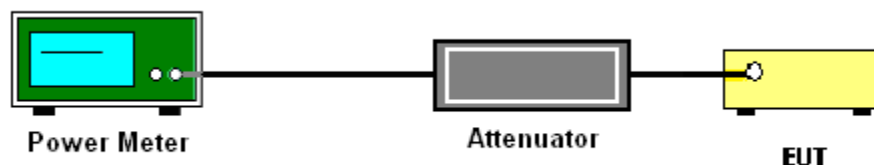

3.2.5 Test Result of Maximum Conducted Output Power

Please refer to Appendix A.



3.3 Power Spectral Density Measurement

3.3.1 Limit of Power Spectral Density

For the band 5.725–5.85 GHz, the maximum power spectral density shall not exceed 30 dBm in any 500-kHz band.

If transmitting antennas of directional gain greater than 6 dBi are used, the peak output power shall be reduced by the amount in dB that the directional gain of the antenna exceeds 6 dBi.

3.3.2 Measuring Instruments

See list of measuring equipment of this test report.

3.3.3 Test Procedures

The testing follows FCC KDB 789033 D02 General UNII Test Procedures New Rules v02r01.
Section F) Maximum power spectral density.

Method SA-2

(trace averaging across on and off times of the EUT transmissions, followed by duty cycle correction).

- Measure the duty cycle.
- Set span to encompass the entire emission bandwidth (EBW) of the signal.
- Set RBW = 300 kHz.
- Set VBW \geq 1 MHz.
- Number of points in sweep \geq 2 Span / RBW.
- Sweep time = auto.
- Detector = RMS
- Trace average at least 100 traces in power averaging mode.
- Add $10 \log(500\text{kHz}/\text{RBW})$ to the test result.
- Add $10 \log(1/x)$, where x is the duty cycle, to the measured power in order to compute the average power during the actual transmission times. For example, add $10 \log(1/0.25) = 6$ dB if the duty cycle is 25 percent.

1. The RF output of EUT was connected to the spectrum analyzer by a low loss cable.
2. Each plot has already offset with cable loss, and attenuator loss. Measure the PPSD and record it.
3. For MIMO mode, calculation method follows FCC KDB 662911 D01 Multiple Transmitter Output v02r01.

Method (c): Measure and add $10 \log(N_{\text{ANT}})$ dB.

With this technique, spectrum measurements are performed at each output of the device, but rather than summing the spectra or the spectral peaks across the outputs, the quantity $10 \log(N_{\text{ANT}})$ dB is added to each spectrum value before comparing to the emission limit. The addition of $10 \log(N_{\text{ANT}})$ dB serves to apportion the emission limit among the N_{ANT} outputs so that each output is permitted to contribute no more than $1/N_{\text{ANT}}^{\text{th}}$ of the PSD limit.

3.3.4 Test Setup

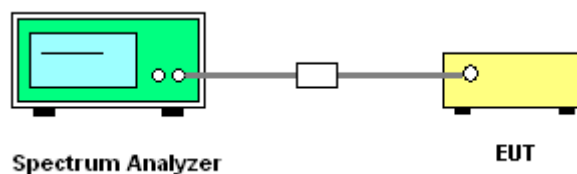



3.3.5 Test Result of Power Spectral Density

Please refer to Appendix A.

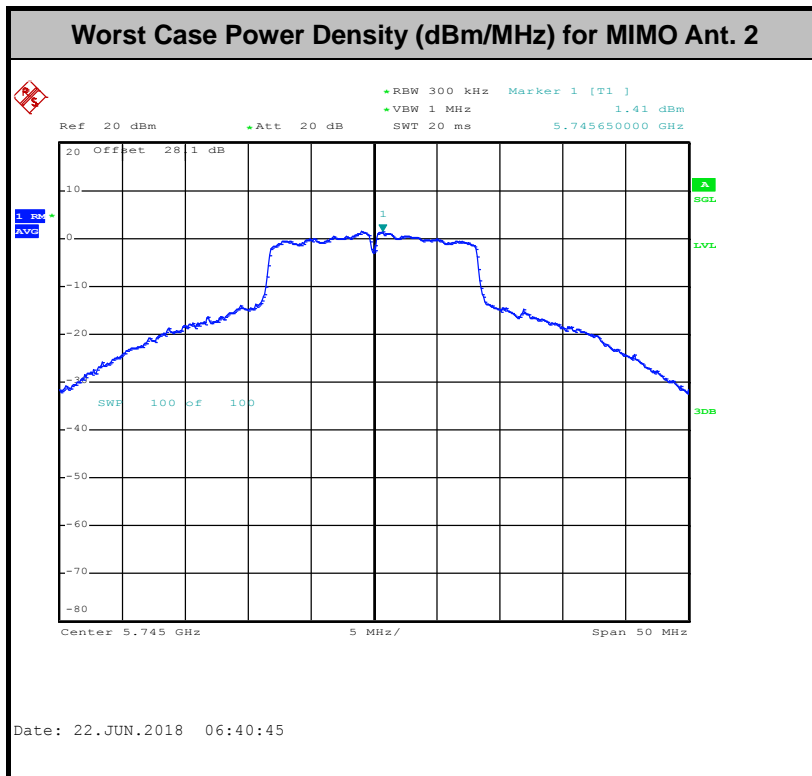
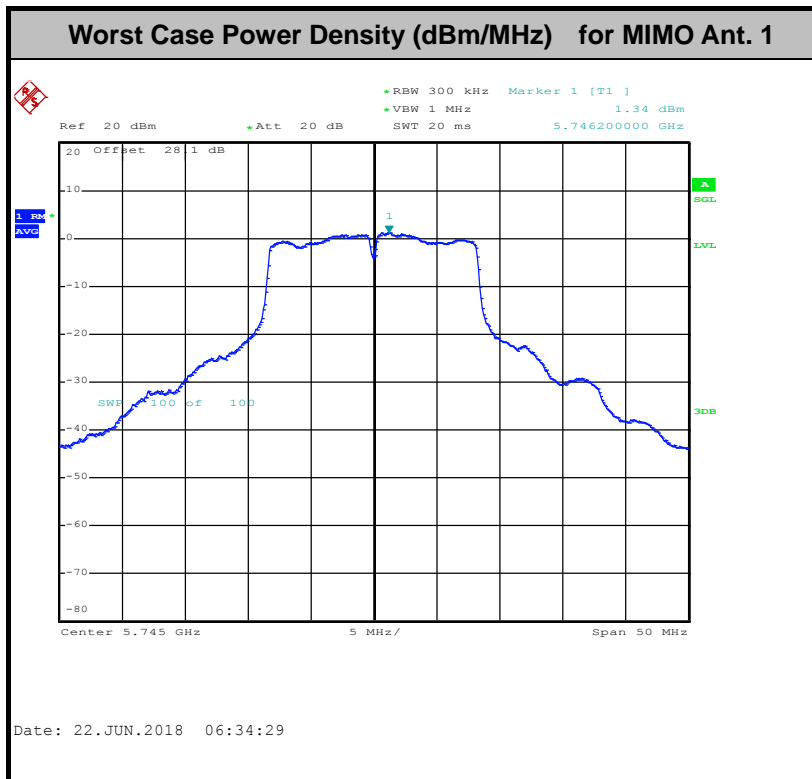



3.4 Unwanted Emissions Measurement

This section is to measure unwanted emissions through radiated measurement for band edge spurious emissions and out of band emissions measurement.

3.4.1 Limit of Unwanted Emissions

- (1) For transmitters operating in the 5.725-5.85 GHz band:
 15.407(b)(4)(i) All emissions shall be limited to a level of -27 dBm/MHz at 75 MHz or more above or below the band edge increasing linearly to 10 dBm/MHz at 25 MHz above or below the band edge, and from 25 MHz above or below the band edge increasing linearly to a level of 15.6 dBm/MHz at 5 MHz above or below the band edge, and from 5 MHz above or below the band edge increasing linearly to a level of 27 dBm/MHz at the band edge.
- (2) Unwanted spurious emissions fallen in restricted bands shall comply with the general field strength limits as below table,

Frequency (MHz)	Field Strength (microvolts/meter)	Measurement Distance (meters)
0.009 – 0.490	2400/F(kHz)	300
0.490 – 1.705	24000/F(kHz)	30
1.705 – 30.0	30	30
30 – 88	100	3
88 – 216	150	3
216 - 960	200	3
Above 960	500	3

Note: The following formula is used to convert the EIRP to field strength.

$$E = \frac{1000000\sqrt{30P}}{3} \text{ } \mu\text{V/m, where P is the eirp (Watts)}$$



EIRP (dBm)	Field Strength at 3m (dBμV/m)
- 27	68.3

(3) KDB789033 D02 v02r01 G)2)c)

- (i) Section 15.407(b)(1) to (b)(3) specify the unwanted emission limits for the U-NII-1 and U-NII-2 bands. As specified, emissions above 1000 MHz that are outside of the restricted bands are subject to a peak emission limit of -27 dBm/MHz.³
- (ii) Section 15.407(b)(4) specifies the unwanted emission limit for the U-NII-3 band. A band emissions mask is specified in Section 15.407(b)(4)(i). The emission limits are in terms of a Peak detector. An alternative to the band emissions mask is specified in Section 15.407(b)(4)(ii). The alternative limits are based on the highest antenna gain specified in the filing. There are also marketing and importation restrictions for the devices using the alternative limit.⁴

Note 3: An out-of-band emission that complies with both the average and peak limits of Section 15.209 is not required to satisfy the -27 dBm/MHz peak emission limit.

Note 4: Only devices with antenna gains of 10 dBi or less may be approved using the emission limits specified in Section 15.247(d) till March 2, 2018; all other devices operating in this band must use the mask specified in Section 15.407(b)(4)(i).

3.4.2 Measuring Instruments

See list of measuring equipment of this test report.



3.4.3 Test Procedures

1. The testing follows FCC KDB 789033 D02 General UNII Test Procedures New Rules v02r01. Section G) Unwanted emissions measurement.
 - (1) Procedure for Unwanted Emissions Measurements Below 1000MHz
 - RBW = 120 kHz
 - VBW = 300 kHz
 - Detector = Peak
 - Trace mode = max hold
 - (2) Procedure for Peak Unwanted Emissions Measurements Above 1000 MHz
 - RBW = 1 MHz
 - VBW \geq 3 MHz
 - Detector = Peak
 - Sweep time = auto
 - Trace mode = max hold
 - (3) Procedures for Average Unwanted Emissions Measurements Above 1000MHz
 - RBW = 1 MHz
 - VBW = 10 Hz, when duty cycle is no less than 98 percent.
 - VBW \geq 1/T, when duty cycle is less than 98 percent where T is the minimum transmission duration over which the transmitter is on and is transmitting at its maximum power control level for the tested mode of operation.



2. The EUT was placed on a turntable with 0.8 meter for frequency below 1GHz and 1.5 meter for frequency above 1GHz respectively above ground.
3. The EUT was set 3 meters from the interference receiving antenna which was mounted on the top of a variable height antenna tower.
4. The antenna is a broadband antenna and its height is adjusted between one meter and four meters above ground to find the maximum value of the field strength for both horizontal polarization and vertical polarization of the antenna.
5. For each suspected emission, the EUT was arranged to its worst case and then adjust the antenna tower (from 1 m to 4 m) and turntable (from 0 degree to 360 degrees) to find the maximum reading.
6. For testing below 1GHz, if the emission level of the EUT in peak mode was 3 dB lower than the limit specified, then peak values of EUT will be reported, otherwise, the emissions will be repeated one by one using the CISPR quasi-peak method and reported.
7. For testing above 1GHz, the emission level of the EUT in peak mode was 20dB lower than average limit (that means the emission level in average mode also complies with the limit in average mode), then peak values of EUT will be reported, otherwise, the emissions will be measured in average mode again and reported.

3.4.4 Test Setup

For radiated emissions below 30MHz

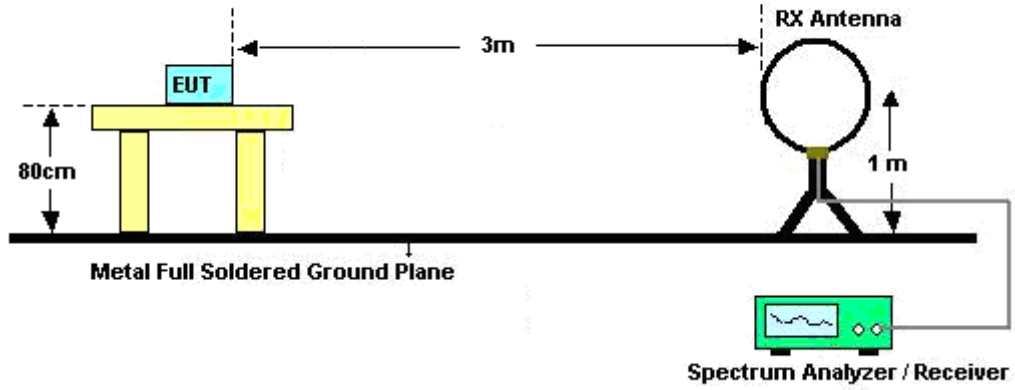

For radiated emissions from 30MHz to 1GHz

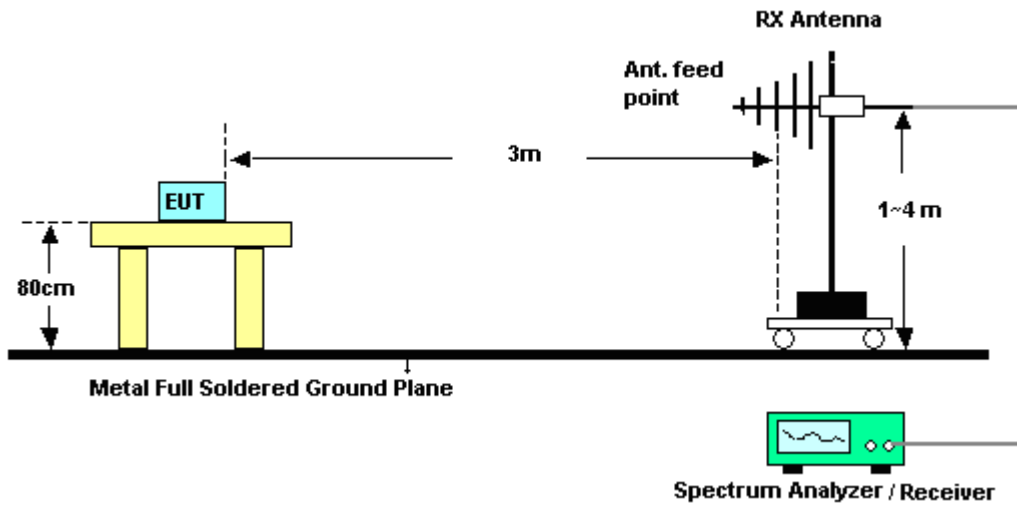

For radiated emissions above 1GHz

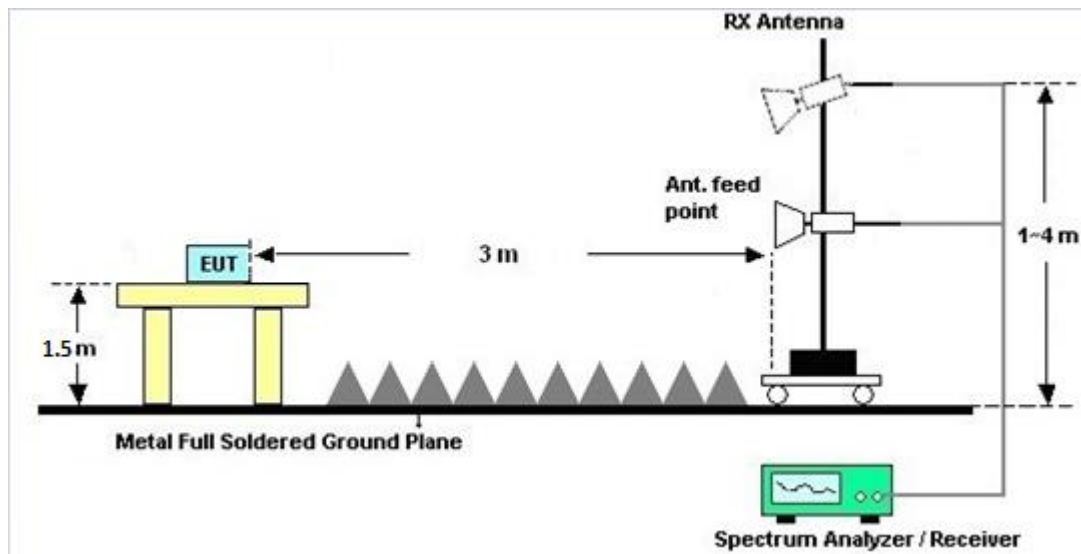

3.4.5 Test Results of Radiated Emissions (9 kHz ~ 30 MHz)

The low frequency, which started from 9 kHz to 30MHz, was pre-scanned and the result which was 20dB lower than the limit line was not reported.

There is a comparison data of both open-field test site and semi-Anechoic chamber, and the result came out very similar.

3.4.6 Test Result of Radiated Band Edges

Please refer to Appendix C and D.

3.4.7 Duty Cycle

Please refer to Appendix E.

3.4.8 Test Result of Unwanted Radiated Emission (30MHz ~ 10th Harmonic)

Please refer to Appendix C and D.



3.5 AC Conducted Emission Measurement

3.5.1 Limit of AC Conducted Emission

For equipment that is designed to be connected to the public utility (AC) power line, the radio frequency voltage that is conducted back onto the AC power line on any frequency or frequencies within the band 150 kHz to 30 MHz shall not exceed the limits in the following table.

Frequency of emission (MHz)	Conducted limit (dB μ V)	
	Quasi-peak	Average
0.15-0.5	66 to 56*	56 to 46*
0.5-5	56	46
5-30	60	50

*Decreases with the logarithm of the frequency.

3.5.2 Measuring Instruments

See list of measuring equipment of this test report.

3.5.3 Test Procedures

1. The EUT was placed 0.4 meter from the conducting wall of the shielding room was kept at least 80 centimeters from any other grounded conducting surface.
2. Connect EUT to the power mains through a line impedance stabilization network (LISN).
3. All the support units are connecting to the other LISN.
4. The LISN provides 50 ohm coupling impedance for the measuring instrument.
5. The FCC states that a 50 ohm, 50 microhenry LISN should be used.
6. Both sides of AC line were checked for maximum conducted interference.
7. The frequency range from 150 kHz to 30 MHz was searched.
8. Set the test-receiver system to Peak Detect Function and specified bandwidth with Maximum Hold Mode.

3.5.4 Test Setup

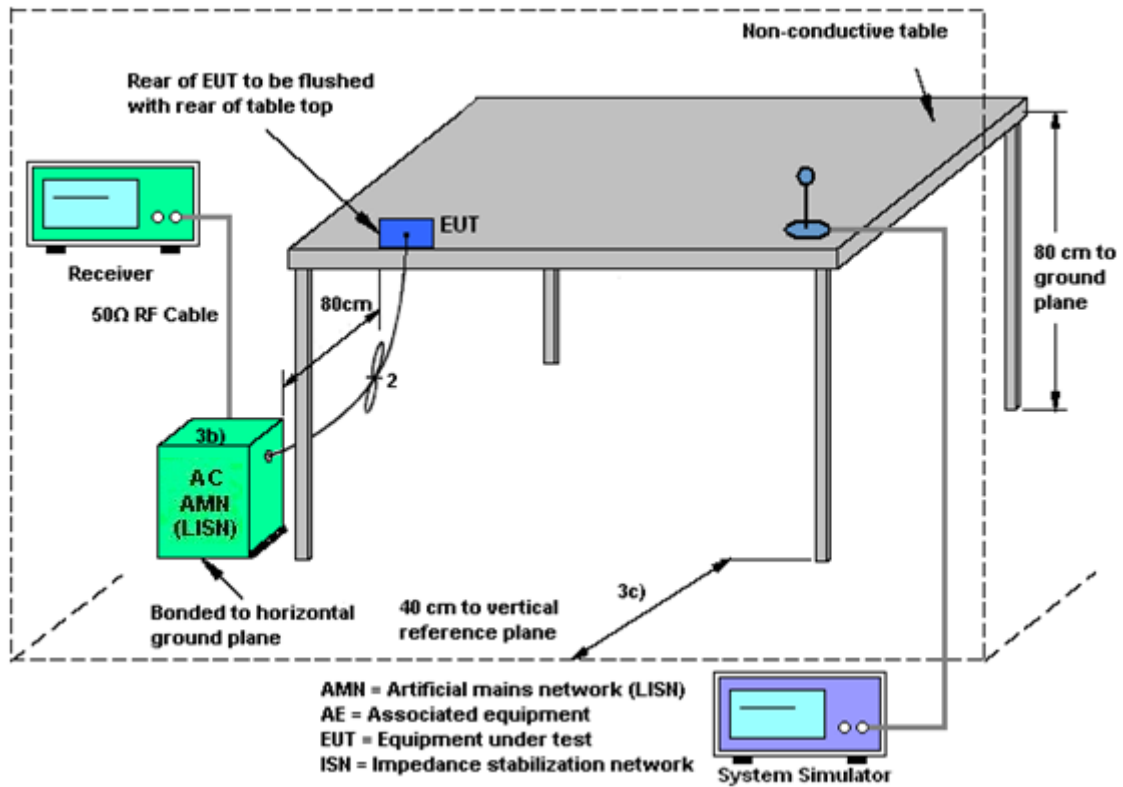

3.5.5 Test Result of AC Conducted Emission

Please refer to Appendix B.



3.6 Automatically Discontinue Transmission

3.6.1 Limit of Automatically Discontinue Transmission

The device shall automatically discontinue transmission in case of either absence of information to transmit or operational failure. These provisions are not intended to preclude the transmission of control or signaling information or the use of repetitive codes used by certain digital technologies to complete frame or burst intervals. Applicants shall include in their application for equipment authorization to describe how this requirement is met.

3.6.2 Measuring Instruments

See list of measuring equipment of this test report.

3.6.3 Test Result of Automatically Discontinue Transmission

While the EUT is not transmitting any information, the EUT does automatically discontinue transmission and become standby mode for power saving. The EUT does detect the controlling signal of ACK message transmitting from remote device and verify whether it shall resend or discontinue transmission.



3.7 Antenna Requirements

3.7.1 Standard Applicable

If transmitting antenna directional gain is greater than 6 dBi, both the peak transmit power and the peak power spectral density shall be reduced by the amount in dB that the directional gain of the antenna exceeds 6 dBi.

3.7.2 Antenna Anti-Replacement Construction

An embedded-in antenna design is used.

3.7.3 Antenna Gain

<CDD Modes >

FCC KDB 662911 D01 Multiple Transmitter Output v02r01

For CDD transmissions, directional gain is calculated as

Directional gain = GANT + Array Gain, where Array Gain is as follows.

For power spectral density (PSD) measurements on all devices,

Array Gain = 10 log(NANT/NSS=1) dB.

For power measurements on IEEE 802.11 devices,

Array Gain = 0 dB (i.e., no array gain) for NANT ≤ 4.

Directional gain may be calculated by using the formulas applicable to equal gain antennas with GANT set equal to the gain of the antenna having the highest gain;

The EUT supports CDD mode.

For power, the directional gain GANT is set equal to the antenna having the highest gain, i.e., F)2)f)i).

For PSD, the directional gain calculation is following F)2)f)ii) of KDB 662911 D01 v02r01.

The power and PSD limit should be modified if the directional gain of EUT is over 6 dBi,

The directional gain “DG” is calculated as following table.

<CDD Modes>						
			DG	DG	Power	PSD
			for	for	Limit	Limit
	Ant. 1	Ant. 2	Power	PSD	Reduction	Reduction
	(dBi)	(dBi)	(dBi)	(dBi)	(dB)	(dB)
Band IV	-0.30	-0.40	-0.30	2.66	0.00	0.00

Power Limit Reduction = DG(Power) – 6dBi, (min = 0)

PSD Limit Reduction = DG(PSD) – 6dBi, (min = 0)



4 List of Measuring Equipment

Instrument	Manufacturer	Model No.	Serial No.	Characteristics	Calibration Date	Test Date	Due Date	Remark
Power Meter	Anritsu	ML2495A	1240001	N/A	Sep. 07, 2017	Jun. 06, 2018~ Jun. 25, 2018	Sep. 06, 2018	Conducted (TH05-HY)
Power Sensor	Anritsu	MA2411B	1207349	300MHz~40GHz	Sep. 07, 2017	Jun. 06, 2018~ Jun. 25, 2018	Sep. 06, 2018	Conducted (TH05-HY)
Spectrum Analyzer	Rohde & Schwarz	FSP40	100057	9kHz-40GHz	Nov. 21, 2017	Jun. 06, 2018~ Jun. 25, 2018	Nov. 20, 2018	Conducted (TH05-HY)
Switch Box & RF Cable	Burgeon	ETF-058	EC130048 4	N/A	Mar. 01, 2018	Jun. 06, 2018~ Jun. 25, 2018	Feb. 28, 2019	Conducted (TH05-HY)
Hygrometer	Testo	DTM-303A	TP157075	N/A	Mar. 06, 2018	Jun. 06, 2018~ Jun. 25, 2018	Mar. 05, 2019	Conducted (TH05-HY)
AC Power Source	ChainTek	APC-1000W	N/A	N/A	N/A	Jun. 23, 2018	N/A	Conduction (CO05-HY)
EMI Test Receiver	Rohde & Schwarz	ESR3	102388	3.6GHz	Dec. 08, 2017	Jun. 23, 2018	Dec. 07, 2018	Conduction (CO05-HY)
LISN	Rohde & Schwarz	ENV216	100080	9kHz~30MHz	Nov. 30, 2017	Jun. 23, 2018	Nov. 29, 2018	Conduction (CO05-HY)
Software	Rohde & Schwarz	EMC32 V10.30	N/A	N/A	N/A	Jun. 23, 2018	N/A	Conduction (CO05-HY)
LF Cable	HUBER + SUHNER	RG-214/U	LF01	N/A	Jan. 03, 2018	Jun. 23, 2018	Jan. 02, 2019	Conduction (CO05-HY)
Pulse Limiter	Rohde & Schwarz	ESH3-Z2	100851	N/A	Jan. 03, 2018	Jun. 23, 2018	Jan. 02, 2019	Conduction (CO05-HY)
Hygrometer	Testo	608-H1	34913912	N/A	Mar. 06, 2018	Jun. 23, 2018	Mar. 05, 2019	Conduction (CO05-HY)
Amplifier	MITEQ	TTA1840-35- HG	1871923	18GHz~40GHz, VSWR : 2.5:1 max	Jul. 18, 2017	Jun. 12, 2018~ Jun. 26, 2018	Jul. 17, 2018	Radiation (03CH15-HY)
Amplifier	SONOMA	310N	363440	9kHz~1GHz	Dec. 26, 2017	Jun. 12, 2018~ Jun. 26, 2018	Dec. 25, 2018	Radiation (03CH15-HY)
Bilog Antenna	TESEQ	CBL6111D& 00800N1D0 1N-06	41912&05	30MHz to 1GHz	Jan. 10, 2018	Jun. 12, 2018~ Jun. 26, 2018	Jan. 09, 2019	Radiation (03CH15-HY)
Horn Antenna	SCHWARZBE CK	BBHA 9120D	9120D-162 0	1G~18GHz	Oct. 03, 2017	Jun. 12, 2018~ Jun. 26, 2018	Oct. 02, 2018	Radiation (03CH15-HY)
Loop Antenna	Rohde & Schwarz	HFH2-Z2	100488	9 kHz~30 MHz	Nov. 23, 2017	Jun. 12, 2018~ Jun. 26, 2018	Nov. 22, 2018	Radiation (03CH15-HY)
Preamplifier	Keysight	83017A	MY532701 95	1GHz~26.5GHz	Aug. 21, 2017	Jun. 12, 2018~ Jun. 26, 2018	Aug. 20, 2018	Radiation (03CH15-HY)
EMI Test Receiver	Keysight	N9038A (MXE)	MY541300 85	20Hz ~ 8.4GHz	Oct. 31, 2017	Jun. 12, 2018~ Jun. 26, 2018	Oct. 30, 2018	Radiation (03CH15-HY)
Spectrum Analyzer	Agilent	E4446A	MY501801 36	3Hz~44GHz	Apr. 25, 2018	Jun. 12, 2018~ Jun. 26, 2018	Apr. 24, 2019	Radiation (03CH15-HY)
Controller	ChainTek	3000-1	N/A	Control Turn table & Ant Mast	N/A	Jun. 12, 2018~ Jun. 26, 2018	N/A	Radiation (03CH15-HY)
Antenna Mast	ChainTek	MBS-520-1	N/A	1m~4m	N/A	Jun. 12, 2018~ Jun. 26, 2018	N/A	Radiation (03CH15-HY)
Turn Table	ChainTek	T-200-S-1	N/A	0~360 Degree	N/A	Jun. 12, 2018~ Jun. 26, 2018	N/A	Radiation (03CH15-HY)



Instrument	Manufacturer	Model No.	Serial No.	Characteristics	Calibration Date	Test Date	Due Date	Remark
SHF-EHF Horn Antenna	SCHWARZBECK	BBHA 9170	BBHA9170584	18GHz- 40GHz	Nov. 27, 2017	Jun. 12, 2018~ Jun. 26, 2018	Nov. 26, 2018	Radiation (03CH15-HY)
Preamplifier	Jet-Power	JPA0010180 0-30-10P	160118000 2	1GHz~18GHz	Jul. 31, 2017	Jun. 12, 2018~ Jun. 26, 2018	Jul. 30, 2018	Radiation (03CH15-HY)
RF Cable	HUBER + SUHNER / MTJ Cooperation	SUCOFLEX 104 / 000000-MT1 8A-100	MY36980/ 4, MY9838/4 PE, D3210	30MHz~1GHz	Mar. 15, 2018	Jun. 12, 2018~ Jun. 26, 2018	Mar. 14, 2019	Radiation (03CH15-HY)
RF Cable	HUBER + SUHNER / MTJ Cooperation	SUCOFLEX 104 / 000000-MT1 8A-100	MY36980/ 4, MY9838/4 PE, D3210	1GHz~18GHz	Mar. 15, 2018	Jun. 12, 2018~ Jun. 26, 2018	Mar. 14, 2019	Radiation (03CH15-HY)
RF Cable	HUBER + SUHNER	SUCOFLEX 102	505134/2	30M~40GHz	Oct. 17, 2017	Jun. 12, 2018~ Jun. 26, 2018	Oct. 16, 2018	Radiation (03CH15-HY)
Filter	Wainwright	WHKX8-587 2.5-6750-18 000-40ST	SN3	6.75GHz High Pass	Sep. 18, 2017	Jun. 12, 2018~ Jun. 26, 2018	Sep. 17, 2018	Radiation (03CH15-HY)
Filter	Wainwright	WLK4-1000- 1530-8000-4 0SS	SN11	1G Low Pass	Sep. 18, 2017	Jun. 12, 2018~ Jun. 26, 2018	Sep. 17, 2018	Radiation (03CH15-HY)
Software	Audix	E3 6.2009-8-24	RK-00104 2	N/A	N/A	Jun. 12, 2018~ Jun. 26, 2018	N/A	Radiation (03CH15-HY)
Hygrometer	TECPEL	DTM-303B	TP162976	N/A	Oct. 12, 2017	Jun. 12, 2018~ Jun. 26, 2018	Oct. 11, 2018	Radiation (03CH15-HY)



5 Uncertainty of Evaluation

Uncertainty of Conducted Emission Measurement (150kHz ~ 30MHz)

Measuring Uncertainty for a Level of Confidence of 95% ($U = 2Uc(y)$)	2.70
---	------

Uncertainty of Radiated Emission Measurement (30 MHz ~ 1000 MHz)

Measuring Uncertainty for a Level of Confidence of 95% ($U = 2Uc(y)$)	5.20
---	------

Uncertainty of Radiated Emission Measurement (1000 MHz ~ 18000 MHz)

Measuring Uncertainty for a Level of Confidence of 95% ($U = 2Uc(y)$)	5.50
---	------

Uncertainty of Radiated Emission Measurement (18000 MHz ~ 40000 MHz)

Measuring Uncertainty for a Level of Confidence of 95% ($U = 2Uc(y)$)	5.20
---	------

Appendix A. Test Result of Conducted Test Items

Test Engineer:	Shiming Liu / Rebecca Li	Temperature:	21~25	°C
Test Date:	2018/6/6~2018/6/25	Relative Humidity:	51~54	%

TEST RESULTS DATA
6dB and 26dB EBW and 99% OBW

Band IV													
Mod.	Data Rate	NTX	CH.	Freq. (MHz)	99% Bandwidth (MHz)		26dB Bandwidth (MHz)		6 dB Bandwidth (MHz)		6 dB Bandwidth Min. Limit (MHz)		Pass/Fail
					Ant 1	Ant 2	Ant 1	Ant 2	Ant 1	Ant 2	Ant 1	Ant 2	
11a	6Mbps	2	149	5745	17.10	30.00	27.60	46.50	15.80	15.70	0.5		Pass
11a	6Mbps	2	157	5785	17.00	28.90	28.50	44.70	15.15	15.40	0.5		Pass
11a	6Mbps	2	165	5825	16.95	30.75	28.15	46.40	15.10	15.75	0.5		Pass
HT20	MCS0	2	149	5745	18.10	27.30	28.45	48.10	15.60	17.20	0.5		Pass
HT20	MCS0	2	157	5785	18.05	32.65	28.20	50.04	15.10	17.60	0.5		Pass
HT20	MCS0	2	165	5825	18.15	34.50	28.85	51.00	17.10	17.55	0.5		Pass
HT40	MCS0	2	151	5755	37.00	69.80	54.36	105.36	35.10	35.64	0.5		Pass
HT40	MCS0	2	159	5795	37.10	69.70	54.36	105.51	34.92	35.46	0.5		Pass
VHT80	MCS0	2	155	5775	76.20	95.88	111.04	218.16	75.20	75.36	0.5		Pass

TEST RESULTS DATA
Average Power Table

Band IV														
Mod.	Data Rate	NTX	CH.	Freq. (MHz)	Duty Factor (dB)		Average Conducted Power (dBm)			FCC Conducted Power Limit (dBm)		DG (dBi)		Pass/Fail
					Ant 1	Ant 2	Ant 1	Ant 2	SUM	Ant 1	Ant 2	Ant 1	Ant 2	
11a	6Mbps	1	149	5745	0.10	0.10	17.15	17.65		30.00	30.00	-0.30	-0.40	Pass
11a	6Mbps	1	157	5785	0.10	0.10	15.11	15.33		30.00	30.00	-0.30	-0.40	Pass
11a	6Mbps	1	165	5825	0.10	0.10	14.42	14.80		30.00	30.00	-0.30	-0.40	Pass
HT20	MCS0	1	149	5745	0.11	0.00	16.93	17.06		30.00	30.00	-0.30	-0.40	Pass
HT20	MCS0	1	157	5785	0.11	0.00	17.31	17.51		30.00	30.00	-0.30	-0.40	Pass
HT20	MCS0	1	165	5825	0.11	0.00	15.29	15.44		30.00	30.00	-0.30	-0.40	Pass
HT40	MCS0	1	151	5755	0.18	0.18	17.72	17.80		30.00	30.00	-0.30	-0.40	Pass
HT40	MCS0	1	159	5795	0.18	0.18	17.53	17.70		30.00	30.00	-0.30	-0.40	Pass
VHT20	MCS0	1	149	5745	0.11	0.11	16.91	17.05		30.00	30.00	-0.30	-0.40	Pass
VHT20	MCS0	1	157	5785	0.11	0.11	17.24	17.49		30.00	30.00	-0.30	-0.40	Pass
VHT20	MCS0	1	165	5825	0.11	0.11	15.26	15.40		30.00	30.00	-0.30	-0.40	Pass
VHT40	MCS0	1	151	5755	0.18	0.18	17.70	17.78		30.00	30.00	-0.30	-0.40	Pass
VHT40	MCS0	1	159	5795	0.18	0.18	17.50	17.68		30.00	30.00	-0.30	-0.40	Pass
VHT80	MCS0	1	155	5775	0.36	0.38	17.34	17.49		30.00	30.00	-0.30	-0.40	Pass
11a	6Mbps	2	149	5745	0.10	0.10	17.50	17.67	20.60	30.00		-0.30		Pass
11a	6Mbps	2	157	5785	0.10	0.10	15.14	15.42	18.29	30.00		-0.30		Pass
11a	6Mbps	2	165	5825	0.10	0.10	14.54	14.81	17.69	30.00		-0.30		Pass
HT20	MCS0	2	149	5745	0.11	0.11	17.09	17.11	20.11	30.00		-0.30		Pass
HT20	MCS0	2	157	5785	0.11	0.11	17.36	17.53	20.45	30.00		-0.30		Pass
HT20	MCS0	2	165	5825	0.11	0.11	15.44	15.45	18.45	30.00		-0.30		Pass
HT40	MCS0	2	151	5755	0.22	0.18	17.82	17.83	20.83	30.00		-0.30		Pass
HT40	MCS0	2	159	5795	0.22	0.18	17.62	17.73	20.68	30.00		-0.30		Pass
VHT20	MCS0	2	149	5745	0.11	0.11	17.05	17.09	20.08	30.00		-0.30		Pass
VHT20	MCS0	2	157	5785	0.11	0.11	17.33	17.51	20.43	30.00		-0.30		Pass
VHT20	MCS0	2	165	5825	0.11	0.11	15.42	15.41	18.42	30.00		-0.30		Pass
VHT40	MCS0	2	151	5755	0.18	0.18	17.74	17.80	20.78	30.00		-0.30		Pass
VHT40	MCS0	2	159	5795	0.18	0.18	17.56	17.69	20.64	30.00		-0.30		Pass
VHT80	MCS0	2	155	5775	0.36	0.40	17.36	17.50	20.44	30.00		-0.30		Pass

TEST RESULTS DATA
Power Spectral Density

Band IV																
Mod.	Data Rate	NTX	CH.	Freq. (MHz)	Duty Factor (dB)		10log (500kHz /RBW) Factor (dB)		Average Power Density (dBm/500kHz)			Average PSD Limit (dBm/500kHz)		DG (dBi)		Pass /Fail
					Ant 1	Ant 2	Ant 1	Ant 2	Ant 1	Ant 2	SUM	Ant 1	Ant 2	Ant 1	Ant 2	
11a	6Mbps	2	149	5745	0.10	0.10	2.22	1.44	1.51	6.74	30.00	30.00	2.66	2.66	Pass	
11a	6Mbps	2	157	5785	0.10	0.10	2.22	-0.02	-0.28	5.21	30.00	30.00	2.66	2.66	Pass	
11a	6Mbps	2	165	5825	0.10	0.10	2.22	-1.38	-0.69	4.54	30.00	30.00	2.66	2.66	Pass	
HT20	MCS0	2	149	5745	0.11	0.11	2.22	0.03	0.47	5.70	30.00	30.00	2.66	2.66	Pass	
HT20	MCS0	2	157	5785	0.11	0.11	2.22	1.08	0.83	6.31	30.00	30.00	2.66	2.66	Pass	
HT20	MCS0	2	165	5825	0.11	0.11	2.22	-0.13	-0.62	5.10	30.00	30.00	2.66	2.66	Pass	
HT40	MCS0	2	151	5755	0.22	0.18	2.22	-1.40	-1.83	3.83	30.00	30.00	2.66	2.66	Pass	
HT40	MCS0	2	159	5795	0.22	0.18	2.22	-1.77	-1.76	3.47	30.00	30.00	2.66	2.66	Pass	
VHT80	MCS0	2	155	5775	0.36	0.40	2.22	-4.70	-4.57	0.66	30.00	30.00	2.66	2.66	Pass	

Note: PSD Sum = Max PSD(Ant. 1, Ant. 2) + 10 log (n)



Appendix B. AC Conducted Emission Test Results

Test Engineer :	Kai-Chun Chu	Temperature :	25~27°C
		Relative Humidity :	50~52%

EUT Information

Report NO : 820502-02
 Test Mode : Mode 1
 Test Voltage : 120Vac/60Hz
 Phase : Line

Full Spectrum

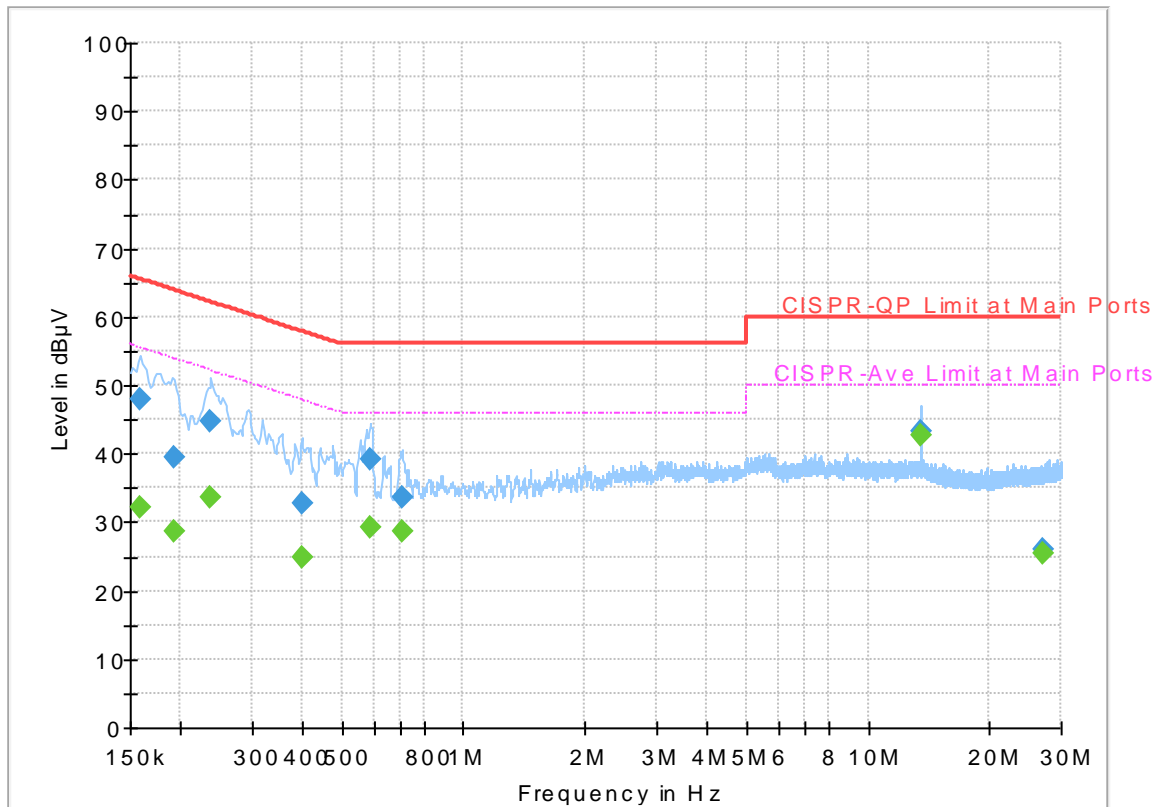

Final_Result

Frequency (MHz)	QuasiPeak (dBµV)	CAverage (dBµV)	Limit (dBµV)	Margin (dB)	Line	Filter	Corr. (dB)
0.159000	---	32.18	55.52	23.34	L1	OFF	19.5
0.159000	47.89	---	65.52	17.63	L1	OFF	19.5
0.192750	---	28.53	53.92	25.39	L1	OFF	19.5
0.192750	39.47	---	63.92	24.45	L1	OFF	19.5
0.237750	---	33.62	52.17	18.55	L1	OFF	19.5
0.237750	44.80	---	62.17	17.37	L1	OFF	19.5
0.397500	---	24.98	47.91	22.93	L1	OFF	19.5
0.397500	32.70	---	57.91	25.21	L1	OFF	19.5
0.588750	---	29.28	46.00	16.72	L1	OFF	19.5
0.588750	39.24	---	56.00	16.76	L1	OFF	19.5
0.703500	---	28.62	46.00	17.38	L1	OFF	19.6
0.703500	33.59	---	56.00	22.41	L1	OFF	19.6
13.560000	---	42.79	50.00	7.21	L1	OFF	20.0
13.560000	43.29	---	60.00	16.71	L1	OFF	20.0
27.120000	---	25.44	50.00	24.56	L1	OFF	20.4
27.120000	26.15	---	60.00	33.85	L1	OFF	20.4

EUT Information

Report NO : 820502-02
 Test Mode : Mode 1
 Test Voltage : 120Vac/60Hz
 Phase : Neutral

Full Spectrum

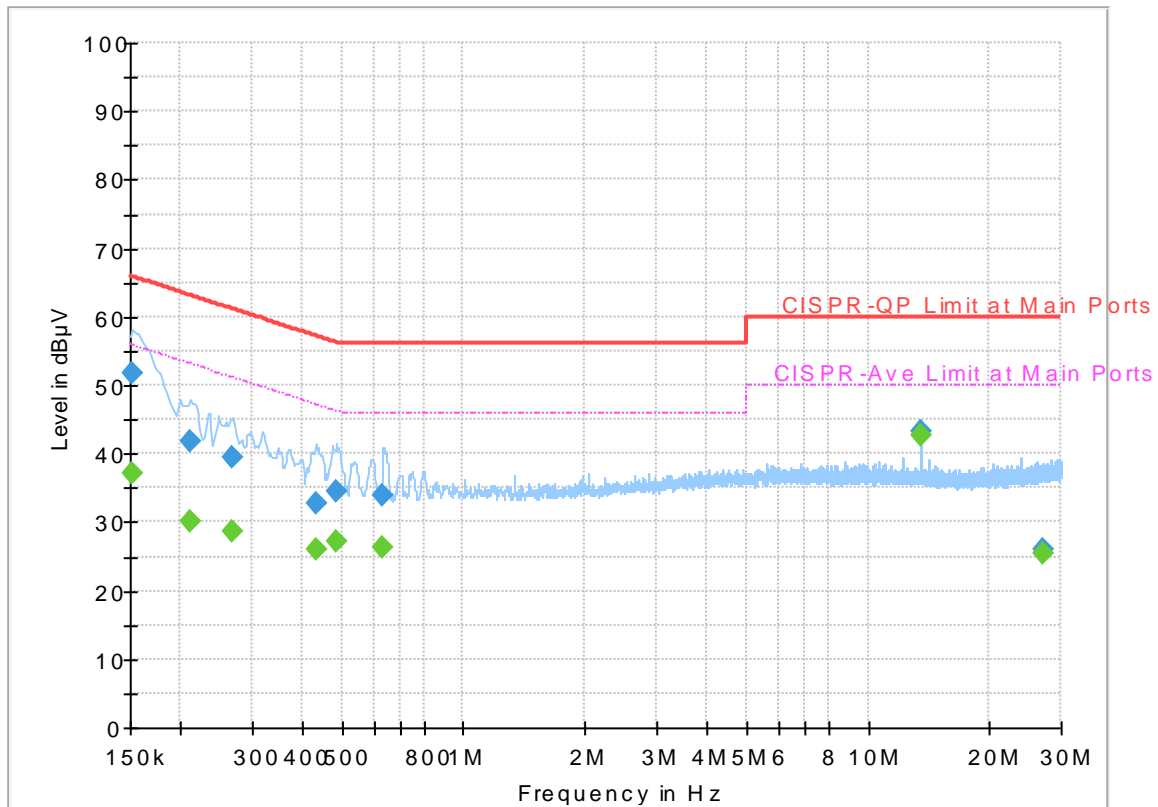

Final_Result

Frequency (MHz)	QuasiPeak (dBµV)	CAverage (dBµV)	Limit (dBµV)	Margin (dB)	Line	Filter	Corr. (dB)
0.152250	---	37.06	55.88	18.82	N	OFF	19.5
0.152250	51.82	---	65.88	14.06	N	OFF	19.5
0.210750	---	30.18	53.18	23.00	N	OFF	19.5
0.210750	41.67	---	63.18	21.51	N	OFF	19.5
0.269250	---	28.53	51.14	22.61	N	OFF	19.5
0.269250	39.47	---	61.14	21.67	N	OFF	19.5
0.431250	---	26.15	47.23	21.08	N	OFF	19.5
0.431250	32.85	---	57.23	24.38	N	OFF	19.5
0.485250	---	27.33	46.25	18.92	N	OFF	19.5
0.485250	34.43	---	56.25	21.82	N	OFF	19.5
0.633750	---	26.18	46.00	19.82	N	OFF	19.6
0.633750	33.95	---	56.00	22.05	N	OFF	19.6
13.560000	---	42.67	50.00	7.33	N	OFF	20.1
13.560000	43.16	---	60.00	16.84	N	OFF	20.1
27.120000	---	25.32	50.00	24.68	N	OFF	20.6
27.120000	25.89	---	60.00	34.11	N	OFF	20.6



Appendix C. Radiated Spurious Emission

Test Engineer :	Bill Chang, Karl Hou, and Lance Chiang	Temperature :	24~26°C
		Relative Humidity :	50~54%

Band 4 - 5725~5850MHz

WIFI 802.11a (Band Edge @ 3m)

WIFI Ant.	Note	Frequency (MHz)	Level (dBμV/m)	Over Limit (dB)	Limit Line (dBμV/m)	Read Level (dBμV)	Antenna Factor (dB/m)	Path Loss (dB)	Preamp Factor (dB)	Ant Pos (cm)	Table Pos (deg)	Peak Avg. (P/A)	Pol. (H/V)
802.11a CH 149 5745MHz		5631.6	50.97	-17.23	68.2	39.84	32.14	9.21	30.22	160	350	P	H
		5699.6	52.52	-52.39	104.91	41.21	32.23	9.33	30.25	160	350	P	H
		5719	62.41	-48.11	110.52	51.03	32.27	9.37	30.26	160	350	P	H
		5724.6	73.65	-47.64	121.29	62.26	32.27	9.38	30.26	160	350	P	H
	*	5745	107.6	-	-	96.16	32.29	9.42	30.27	160	350	P	H
	*	5745	100.62	-	-	89.18	32.29	9.42	30.27	160	350	A	H
		5613	50.46	-17.74	68.2	39.38	32.12	9.17	30.21	248	2	P	V
		5696.4	53.58	-48.97	102.55	42.27	32.23	9.33	30.25	248	2	P	V
		5717.4	61.62	-48.45	110.07	50.26	32.25	9.37	30.26	248	2	P	V
		5725	71.93	-50.27	122.2	60.54	32.27	9.38	30.26	248	2	P	V
	*	5745	108.65	-	-	97.21	32.29	9.42	30.27	248	2	P	V
	*	5745	101.58	-	-	90.14	32.29	9.42	30.27	248	2	A	V



WIFI Ant. 1+2	Note	Frequency (MHz)	Level (dBµV/m)	Over Limit (dB)	Limit Line (dBµV/m)	Read Level (dBµV)	Antenna Factor (dB/m)	Path Loss (dB)	Preamp Factor (dB)	Ant Pos (cm)	Table Pos (deg)	Peak Avg. (P/A)	Pol. (H/V)
802.11a CH 157 5785MHz		5623.8	49.96	-18.24	68.2	38.84	32.14	9.19	30.21	246	339	P	H
		5661.6	50.02	-26.79	76.81	38.8	32.19	9.26	30.23	246	339	P	H
		5714.6	50.71	-58.58	109.29	39.36	32.25	9.36	30.26	246	339	P	H
		5722	49.33	-66.03	115.36	37.94	32.27	9.38	30.26	246	339	P	H
	*	5785	107.6	-	-	96.08	32.33	9.49	30.3	246	339	P	H
	*	5785	100.32	-	-	88.8	32.33	9.49	30.3	246	339	A	H
		5852.6	50.9	-65.37	116.27	39.24	32.41	9.58	30.33	246	339	P	H
		5856.6	50.7	-59.65	110.35	39.01	32.43	9.59	30.33	246	339	P	H
		5897.2	51.12	-37.61	88.73	39.37	32.48	9.63	30.36	246	339	P	H
		5933.6	51.06	-17.14	68.2	39.24	32.52	9.67	30.37	246	339	P	H
		5631.8	50.88	-17.32	68.2	39.75	32.14	9.21	30.22	224	7	P	V
		5676.6	50.16	-37.76	87.92	38.89	32.21	9.29	30.23	224	7	P	V
		5712.6	50.32	-58.41	108.73	38.97	32.25	9.36	30.26	224	7	P	V
		5724.4	49.46	-71.37	120.83	38.07	32.27	9.38	30.26	224	7	P	V
	*	5785	107.65	-	-	96.13	32.33	9.49	30.3	224	7	P	V
	*	5785	100.4	-	-	88.88	32.33	9.49	30.3	224	7	A	V
		5850.4	49.83	-71.46	121.29	38.17	32.41	9.58	30.33	224	7	P	V
		5872.6	50.77	-55.1	105.87	39.05	32.46	9.6	30.34	224	7	P	V
		5880	51.11	-50.38	101.49	39.38	32.46	9.61	30.34	224	7	P	V
		5941.4	51.2	-17	68.2	39.36	32.54	9.68	30.38	224	7	P	V



WiFi Ant. 1+2	Note	Frequency (MHz)	Level (dBμV/m)	Over Limit (dB)	Limit Line (dBμV/m)	Read Level (dBμV)	Antenna Factor (dB/m)	Path Loss (dB)	Preamp Factor (dB)	Ant Pos (cm)	Table Pos (deg)	Peak Avg. (P/A)	Pol. (H/V)
802.11a CH 165 5825MHz	*	5825	106.32	-	-	94.7	32.39	9.55	30.32	244	339	P	H
	*	5825	98.93	-	-	87.31	32.39	9.55	30.32	244	339	A	H
		5851.4	55.34	-63.67	119.01	43.68	32.41	9.58	30.33	244	339	P	H
		5858.4	52.83	-57.02	109.85	41.15	32.43	9.59	30.34	244	339	P	H
		5893.6	51.25	-40.15	91.4	39.5	32.48	9.63	30.36	244	339	P	H
		5946.2	51.35	-16.85	68.2	39.5	32.54	9.69	30.38	244	339	P	H
	*	5825	106.53	-	-	94.91	32.39	9.55	30.32	233	6	P	V
	*	5825	99.13	-	-	87.51	32.39	9.55	30.32	233	6	A	V
		5852.2	54.67	-62.51	117.18	43.01	32.41	9.58	30.33	233	6	P	V
		5855.4	53.84	-56.85	110.69	42.16	32.43	9.58	30.33	233	6	P	V
		5892	51.45	-41.13	92.58	39.7	32.48	9.63	30.36	233	6	P	V
		5943.2	51.49	-16.71	68.2	39.65	32.54	9.68	30.38	233	6	P	V
	Remark	1. No other spurious found. 2. All results are PASS against Peak and Average limit line.											



Band 4 5725~5850MHz

WIFI 802.11a (Harmonic @ 3m)

WIFI Ant. 1+2	Note	Frequency (MHz)	Level (dBμV/m)	Over Limit (dB)	Limit Line (dBμV/m)	Read Level (dBμV)	Antenna Factor (dB/m)	Path Loss (dB)	Preamp Factor (dB)	Ant Pos (cm)	Table Pos (deg)	Peak Avg. (P/A)	Pol. (H/V)
802.11a CH 149 5745MHz		11490	55.35	-18.65	74	62.62	40.41	13.92	61.6	190	67	P	H
		11490	46.24	-7.76	54	53.51	40.41	13.92	61.6	190	67	A	H
		17235	53.25	-14.95	68.2	49.45	41.71	17.88	55.79	100	0	P	H
		11490	60.01	-13.99	74	67.28	40.41	13.92	61.6	157	330	P	V
		11490	50.81	-3.19	54	58.08	40.41	13.92	61.6	157	330	A	V
		17235	54.98	-13.22	68.2	51.18	41.71	17.88	55.79	100	0	P	V
802.11a CH 157 5785MHz		11570	54.36	-19.64	74	61.94	40.22	13.95	61.75	142	64	P	H
		11570	45.16	-8.84	54	52.74	40.22	13.95	61.75	142	64	A	H
		17355	56.12	-12.08	68.2	51.27	42.32	18.06	55.53	100	0	P	H
		11570	60.38	-13.62	74	67.96	40.22	13.95	61.75	137	339	P	V
		11570	50.68	-3.32	54	58.26	40.22	13.95	61.75	137	339	A	V
		17355	55.78	-12.42	68.2	50.93	42.32	18.06	55.53	100	0	P	V
802.11a CH 165 5825MHz		11650	53.29	-20.71	74	61.17	40.04	13.98	61.9	154	77	P	H
		11650	44.3	-9.7	54	52.18	40.04	13.98	61.9	154	77	A	H
		17475	53.7	-14.5	68.2	47.85	42.93	18.19	55.27	100	0	P	H
		11650	60	-14	74	67.88	40.04	13.98	61.9	139	340	P	V
		11650	50.6	-3.4	54	58.48	40.04	13.98	61.9	139	340	A	V
		17475	54.17	-14.03	68.2	48.32	42.93	18.19	55.27	100	0	P	V
Remark	1. No other spurious found. 2. All results are PASS against Peak and Average limit line.												



**Band 4 5725~5850MHz
WIFI 802.11n HT20 (Band Edge @ 3m)**

WIFI Ant. 1+2	Note	Frequency (MHz)	Level (dBμV/m)	Over Limit (dB)	Limit Line (dBμV/m)	Read Level (dBμV)	Antenna Factor (dB/m)	Path Loss (dB)	Preamp Factor (dB)	Ant Pos (cm)	Table Pos (deg)	Peak Avg. (P/A)	Pol. (H/V)
802.11n HT20 CH 149 5745MHz		5606.2	49.75	-18.45	68.2	38.68	32.12	9.16	30.21	164	347	P	H
		5690.4	51.41	-46.71	98.12	40.11	32.23	9.32	30.25	164	347	P	H
		5719.8	60.52	-50.22	110.74	49.14	32.27	9.37	30.26	164	347	P	H
		5724.8	71.55	-50.19	121.74	60.16	32.27	9.38	30.26	164	347	P	H
	*	5745	106.8	-	-	95.36	32.29	9.42	30.27	164	347	P	H
	*	5745	99.53	-	-	88.09	32.29	9.42	30.27	164	347	A	H
		5643.8	50.34	-17.86	68.2	39.16	32.17	9.23	30.22	237	2	P	V
		5700	52.9	-52.3	105.2	41.58	32.23	9.34	30.25	237	2	P	V
		5719.8	67.26	-43.48	110.74	55.88	32.27	9.37	30.26	237	2	P	V
		5725	73.05	-49.15	122.2	61.66	32.27	9.38	30.26	237	2	P	V
	*	5745	107.73	-	-	96.29	32.29	9.42	30.27	237	2	P	V
	*	5745	100.33	-	-	88.89	32.29	9.42	30.27	237	2	A	V



WIFI Ant. 1+2	Note	Frequency (MHz)	Level (dBµV/m)	Over Limit (dB)	Limit Line (dBµV/m)	Read Level (dBµV)	Antenna Factor (dB/m)	Path Loss (dB)	Preamp Factor (dB)	Ant Pos (cm)	Table Pos (deg)	Peak Avg. (P/A)	Pol. (H/V)
802.11n HT20 CH 157 5785MHz		5622	50.33	-17.87	68.2	39.21	32.14	9.19	30.21	176	352	P	H
		5678.6	50.47	-38.93	89.4	39.19	32.21	9.3	30.23	176	352	P	H
		5718.8	48.91	-61.55	110.46	37.53	32.27	9.37	30.26	176	352	P	H
		5722	49.85	-65.51	115.36	38.46	32.27	9.38	30.26	176	352	P	H
	*	5785	107.01	-	-	95.49	32.33	9.49	30.3	176	352	P	H
	*	5785	99.7	-	-	88.18	32.33	9.49	30.3	176	352	A	H
		5851.8	49.22	-68.88	118.1	37.56	32.41	9.58	30.33	176	352	P	H
		5858.8	50.3	-59.43	109.73	38.62	32.43	9.59	30.34	176	352	P	H
		5901	50.93	-34.99	85.92	39.17	32.48	9.64	30.36	176	352	P	H
		5944.4	49.81	-18.39	68.2	37.96	32.54	9.69	30.38	176	352	P	H
		5627.8	50.94	-17.26	68.2	39.81	32.14	9.2	30.21	234	2	P	V
		5690	51.33	-46.5	97.83	40.03	32.23	9.32	30.25	234	2	P	V
		5710.8	51.52	-56.71	108.23	40.18	32.25	9.35	30.26	234	2	P	V
		5721.4	52.07	-61.92	113.99	40.69	32.27	9.37	30.26	234	2	P	V
	*	5785	107.87	-	-	96.35	32.33	9.49	30.3	234	2	P	V
	*	5785	100.58	-	-	89.06	32.33	9.49	30.3	234	2	A	V
		5853.6	50.43	-63.56	113.99	38.75	32.43	9.58	30.33	234	2	P	V
		5869.4	51.62	-55.15	106.77	39.93	32.43	9.6	30.34	234	2	P	V
	5918.8	51.12	-21.65	72.77	39.33	32.5	9.66	30.37	234	2	P	V	
	5925	50.22	-17.98	68.2	38.41	32.52	9.66	30.37	234	2	P	V	



WIFI Ant. 1+2	Note	Frequency (MHz)	Level (dBμV/m)	Over Limit (dB)	Limit Line (dBμV/m)	Read Level (dBμV)	Antenna Factor (dB/m)	Path Loss (dB)	Preamp Factor (dB)	Ant Pos (cm)	Table Pos (deg)	Peak Avg. (P/A)	Pol. (H/V)
802.11n HT20 CH 165 5825MHz	*	5825	106.93	-	-	95.31	32.39	9.55	30.32	245	339	P	H
	*	5825	99.4	-	-	87.78	32.39	9.55	30.32	245	339	A	H
		5850.2	54.86	-66.88	121.74	43.2	32.41	9.58	30.33	245	339	P	H
		5855.4	54.01	-56.68	110.69	42.33	32.43	9.58	30.33	245	339	P	H
		5879.4	51.48	-50.45	101.93	39.75	32.46	9.61	30.34	245	339	P	H
		5929.2	50.83	-17.37	68.2	39.01	32.52	9.67	30.37	245	339	P	H
	*	5825	106.27	-	-	94.65	32.39	9.55	30.32	171	342	P	V
	*	5825	98.54	-	-	86.92	32.39	9.55	30.32	171	342	A	V
		5850	63.84	-58.36	122.2	52.18	32.41	9.58	30.33	171	342	P	V
		5869.4	53.51	-53.26	106.77	41.82	32.43	9.6	30.34	171	342	P	V
		5875	51.8	-53.4	105.2	40.07	32.46	9.61	30.34	171	342	P	V
		5944.8	51.6	-16.6	68.2	39.75	32.54	9.69	30.38	171	342	P	V
Remark	1. No other spurious found. 2. All results are PASS against Peak and Average limit line.												



Band 4 5725~5850MHz
WIFI 802.11n HT20 (Harmonic @ 3m)

WIFI Ant. 1+2	Note	Frequency (MHz)	Level (dBμV/m)	Over Limit (dB)	Limit Line (dBμV/m)	Read Level (dBμV)	Antenna Factor (dB/m)	Path Loss (dB)	Preamp Factor (dB)	Ant Pos (cm)	Table Pos (deg)	Peak Avg. (P/A)	Pol. (H/V)
802.11n HT20 CH 149 5745MHz		11490	57.7	-16.3	74	64.97	40.41	13.92	61.6	190	71	P	H
		11490	46.1	-7.9	54	53.37	40.41	13.92	61.6	190	71	A	H
		17235	52.52	-15.68	68.2	48.72	41.71	17.88	55.79	100	0	P	H
		11490	61.28	-12.72	74	68.55	40.41	13.92	61.6	137	339	P	V
		11490	49.03	-4.97	54	56.3	40.41	13.92	61.6	137	339	A	V
		17235	54.42	-13.78	68.2	50.62	41.71	17.88	55.79	100	0	P	V
802.11n HT20 CH 157 5785MHz		11570	56.11	-17.89	74	63.69	40.22	13.95	61.75	125	64	P	H
		11570	46.2	-7.8	54	53.78	40.22	13.95	61.75	125	64	A	H
		17355	57.73	-10.47	68.2	52.88	42.32	18.06	55.53	100	0	P	H
		11570	59.1	-14.9	74	66.68	40.22	13.95	61.75	215	326	P	V
		11570	48.38	-5.62	54	55.96	40.22	13.95	61.75	215	326	A	V
		17355	56.25	-11.95	68.2	51.4	42.32	18.06	55.53	100	0	P	V
802.11n HT20 CH 165 5825MHz		11650	57.61	-16.39	74	65.49	40.04	13.98	61.9	153	68	P	H
		11650	46.2	-7.8	54	54.08	40.04	13.98	61.9	153	68	A	H
		17475	54.12	-14.08	68.2	48.27	42.93	18.19	55.27	100	0	P	H
		11650	62.67	-11.33	74	70.55	40.04	13.98	61.9	149	328	P	V
		11650	50.56	-3.44	54	58.44	40.04	13.98	61.9	149	328	A	V
		17475	55.91	-12.29	68.2	50.06	42.93	18.19	55.27	100	0	P	V
Remark	1. No other spurious found. 2. All results are PASS against Peak and Average limit line.												



Band 4 5725~5850MHz
WIFI 802.11n HT40 (Band Edge @ 3m)

WIFI Ant. 1+2	Note	Frequency (MHz)	Level (dBμV/m)	Over Limit (dB)	Limit Line (dBμV/m)	Read Level (dBμV)	Antenna Factor (dB/m)	Path Loss (dB)	Preamp Factor (dB)	Ant Pos (cm)	Table Pos (deg)	Peak Avg. (P/A)	Pol. (H/V)
802.11n HT40 CH 151 5755MHz		5618.6	55.67	-12.53	68.2	44.56	32.14	9.18	30.21	203	349	P	H
		5699.8	60.92	-44.13	105.05	49.61	32.23	9.33	30.25	203	349	P	H
		5718.8	79.21	-31.25	110.46	67.83	32.27	9.37	30.26	203	349	P	H
		5723	79.33	-38.31	117.64	67.94	32.27	9.38	30.26	203	349	P	H
	*	5755	104.98	-	-	93.5	32.31	9.44	30.27	203	349	P	H
	*	5755	97.17	-	-	85.69	32.31	9.44	30.27	203	349	A	H
		5850.4	50.65	-70.64	121.29	38.99	32.41	9.58	30.33	203	349	P	H
		5867.4	51.9	-55.43	107.33	40.21	32.43	9.6	30.34	203	349	P	H
		5883.6	53.72	-45.09	98.81	42	32.46	9.62	30.36	203	349	P	H
		5931.2	52.93	-15.27	68.2	41.11	32.52	9.67	30.37	203	349	P	H
		5618.8	51.3	-16.9	68.2	40.19	32.14	9.18	30.21	233	4	P	V
		5697.6	59.93	-43.5	103.43	48.62	32.23	9.33	30.25	233	4	P	V
		5719.4	75.53	-35.1	110.63	64.15	32.27	9.37	30.26	233	4	P	V
		5720.4	77.05	-34.66	111.71	65.67	32.27	9.37	30.26	233	4	P	V
	*	5755	104.15	-	-	92.67	32.31	9.44	30.27	233	4	P	V
	*	5755	96.67	-	-	85.19	32.31	9.44	30.27	233	4	A	V
		5853.6	52.46	-61.53	113.99	40.78	32.43	9.58	30.33	233	4	P	V
		5867.4	51.63	-55.7	107.33	39.94	32.43	9.6	30.34	233	4	P	V
		5909.4	52.2	-27.51	79.71	40.42	32.5	9.65	30.37	233	4	P	V
		5934.6	50.54	-17.66	68.2	38.73	32.52	9.67	30.38	233	4	P	V



WIFI Ant. 1+2	Note	Frequency (MHz)	Level (dBμV/m)	Over Limit (dB)	Limit Line (dBμV/m)	Read Level (dBμV)	Antenna Factor (dB/m)	Path Loss (dB)	Preamp Factor (dB)	Ant Pos (cm)	Table Pos (deg)	Peak Avg. (P/A)	Pol. (H/V)
802.11n HT40 CH 159 5795MHz		5613.8	50.06	-18.14	68.2	38.97	32.12	9.18	30.21	309	347	P	H
		5692.4	51.2	-48.4	99.6	39.9	32.23	9.32	30.25	309	347	P	H
		5717	53.92	-56.04	109.96	42.56	32.25	9.37	30.26	309	347	P	H
		5723	54.25	-63.39	117.64	42.86	32.27	9.38	30.26	309	347	P	H
	*	5795	105.34	-	-	93.78	32.35	9.51	30.3	309	347	P	H
	*	5795	97.54	-	-	85.98	32.35	9.51	30.3	309	347	A	H
		5851	57.64	-62.28	119.92	45.98	32.41	9.58	30.33	309	347	P	H
		5866.4	56.52	-51.09	107.61	44.83	32.43	9.6	30.34	309	347	P	H
		5880.8	54.93	-45.96	100.89	43.2	32.46	9.61	30.34	309	347	P	H
		5926.8	51.13	-17.07	68.2	39.31	32.52	9.67	30.37	309	347	P	H
		5643.2	49.53	-18.67	68.2	38.35	32.17	9.23	30.22	215	0	P	V
		5696.4	53.41	-49.14	102.55	42.1	32.23	9.33	30.25	215	0	P	V
		5715	58.35	-51.05	109.4	47	32.25	9.36	30.26	215	0	P	V
		5720	53.14	-57.66	110.8	41.76	32.27	9.37	30.26	215	0	P	V
	*	5795	104.92	-	-	93.36	32.35	9.51	30.3	215	0	P	V
	*	5795	97.49	-	-	85.93	32.35	9.51	30.3	215	0	A	V
		5854	54.45	-58.63	113.08	42.77	32.43	9.58	30.33	215	0	P	V
		5857.6	55.25	-54.82	110.07	43.56	32.43	9.59	30.33	215	0	P	V
	5876	52.96	-51.5	104.46	41.23	32.46	9.61	30.34	215	0	P	V	
	5933.6	50.6	-17.6	68.2	38.78	32.52	9.67	30.37	215	0	P	V	
Remark	1. No other spurious found. 2. All results are PASS against Peak and Average limit line.												



**Band 4 5725~5850MHz
WIFI 802.11n HT40 (Harmonic @ 3m)**

WIFI Ant. 1+2	Note	Frequency (MHz)	Level (dBμV/m)	Over Limit (dB)	Limit Line (dBμV/m)	Read Level (dBμV)	Antenna Factor (dB/m)	Path Loss (dB)	Preamp Factor (dB)	Ant Pos (cm)	Table Pos (deg)	Peak Avg. (P/A)	Pol. (H/V)
802.11n HT40 CH 151 5755MHz		11510	53.52	-20.48	74	60.79	40.4	13.93	61.6	146	58	P	H
		11510	45.3	-8.7	54	52.57	40.4	13.93	61.6	146	58	A	H
		17265	50.19	-18.01	68.2	46.08	41.89	17.93	55.71	100	0	P	H
		11510	55.93	-18.07	74	63.2	40.4	13.93	61.6	121	339	P	V
		11510	47.85	-6.15	54	55.12	40.4	13.93	61.6	121	339	A	V
		17265	51.99	-16.21	68.2	47.88	41.89	17.93	55.71	100	0	P	V
802.11n HT40 CH 159 5795MHz		11590	54.44	-19.56	74	62.09	40.18	13.96	61.79	136	59	P	H
		11590	46.13	-7.87	54	53.78	40.18	13.96	61.79	136	59	A	H
		17385	52.64	-15.56	68.2	47.53	42.49	18.08	55.46	100	0	P	H
		11590	57.97	-16.03	74	65.62	40.18	13.96	61.79	131	339	P	V
		11590	49.65	-4.35	54	57.3	40.18	13.96	61.79	131	339	A	V
		17385	53.3	-14.9	68.2	48.19	42.49	18.08	55.46	100	0	P	V
Remark	1. No other spurious found. 2. All results are PASS against Peak and Average limit line.												



Band 4 5725~5850MHz
WIFI 802.11ac VHT80 (Band Edge @ 3m)

WIFI Ant. 1+2	Note	Frequency (MHz)	Level (dBμV/m)	Over Limit (dB)	Limit Line (dBμV/m)	Read Level (dBμV)	Antenna Factor (dB/m)	Path Loss (dB)	Preamp Factor (dB)	Ant Pos (cm)	Table Pos (deg)	Peak Avg. (P/A)	Pol. (H/V)
802.11ac VHT80 CH 155 5775MHz		5616.2	56.07	-12.13	68.2	44.96	32.14	9.18	30.21	186	333	P	H
		5695.8	73.17	-28.93	102.1	61.86	32.23	9.33	30.25	186	333	P	H
		5718.6	77.61	-32.8	110.41	66.23	32.27	9.37	30.26	186	333	P	H
		5723	77.29	-40.35	117.64	65.9	32.27	9.38	30.26	186	333	P	H
	*	5775	102.56	-	-	91.05	32.33	9.47	30.29	186	333	P	H
	*	5775	95.25	-	-	83.74	32.33	9.47	30.29	186	333	A	H
		5851.2	75.06	-44.4	119.46	63.4	32.41	9.58	30.33	186	333	P	H
		5855	73.35	-37.45	110.8	61.67	32.43	9.58	30.33	186	333	P	H
		5884.2	66.23	-32.14	98.37	54.51	32.46	9.62	30.36	186	333	P	H
		5926	53.73	-14.47	68.2	41.92	32.52	9.66	30.37	186	333	P	H
		5647.8	57.38	-10.82	68.2	46.19	32.17	9.24	30.22	219	0	P	V
		5698.8	71.59	-32.73	104.32	60.28	32.23	9.33	30.25	219	0	P	V
		5715.8	77.1	-32.53	109.63	65.75	32.25	9.36	30.26	219	0	P	V
		5720.2	77.97	-33.29	111.26	66.59	32.27	9.37	30.26	219	0	P	V
	*	5775	101.58	-	-	90.07	32.33	9.47	30.29	219	0	P	V
	*	5775	94.07	-	-	82.56	32.33	9.47	30.29	219	0	A	V
		5851.2	72.15	-47.31	119.46	60.49	32.41	9.58	30.33	219	0	P	V
		5861	72.81	-36.31	109.12	61.13	32.43	9.59	30.34	219	0	P	V
	5877.4	65.22	-38.2	103.42	53.49	32.46	9.61	30.34	219	0	P	V	
	5933.4	52.26	-15.94	68.2	40.44	32.52	9.67	30.37	219	0	P	V	

Remark	1. No other spurious found. 2. All results are PASS against Peak and Average limit line.
---------------	---



Band 4 5725~5850MHz

WIFI 802.11ac VHT80 (Harmonic @ 3m)

WIFI Ant. 1+2	Note	Frequency (MHz)	Level (dBμV/m)	Over Limit (dB)	Limit Line (dBμV/m)	Read Level (dBμV)	Antenna Factor (dB/m)	Path Loss (dB)	Preamp Factor (dB)	Ant Pos (cm)	Table Pos (deg)	Peak Avg. (P/A)	Pol. (H/V)
802.11ac VHT80 CH 155 5775MHz		11550	48.82	-25.18	74	56.31	40.27	13.95	61.71	100	0	P	H
		17325	51.31	-16.89	68.2	46.74	42.15	18.02	55.6	100	0	P	H
		11550	55.07	-18.93	74	62.56	40.27	13.95	61.71	144	331	P	V
		11550	46.09	-7.91	54	53.58	40.27	13.95	61.71	144	331	A	V
		17325	50.69	-17.51	68.2	46.12	42.15	18.02	55.6	100	0	P	V
Remark	1. No other spurious found. 2. All results are PASS against Peak and Average limit line.												



Emission below 1GHz

5GHz WIFI 802.11ac VHT80 (LF @ 3m)

WIFI	Note	Frequency	Level	Over	Limit	Read	Antenna	Path	Preamp	Ant	Table	Peak	Pol.
Ant.				Limit	Line	Level	Factor	Loss	Factor	Pos	Pos	Avg.	
1+2		(MHz)	(dBμV/m)	(dB)	(dBμV/m)	(dBμV)	(dB/m)	(dB)	(dB)	(cm)	(deg)	(P/A)	(H/V)
5GHz 802.11ac VHT80 LF		71.85	27.4	-12.6	40	46.31	12.58	1.03	32.6	-	-	P	H
		170.4	32.8	-10.7	43.5	47.85	15.73	1.57	32.55	-	-	P	H
		211.17	28	-15.5	43.5	42.93	15.73	1.74	32.54	-	-	P	H
		829.9	35.33	-10.67	46	34.94	28.86	3.41	32.06	100	0	P	H
		937.7	33.42	-12.58	46	30.24	30.72	3.61	31.38	-	-	P	H
		944.7	34.95	-11.05	46	31.49	30.91	3.63	31.32	-	-	P	H
		39.72	28.62	-11.38	40	40.79	19.66	0.79	32.63	-	-	P	V
		73.47	28.74	-11.26	40	47.47	12.75	1.04	32.6	100	0	P	V
		173.64	28.57	-14.93	43.5	43.83	15.5	1.59	32.55	-	-	P	V
		562.5	29.69	-16.31	46	33.02	26.25	2.8	32.56	-	-	P	V
		839	31.25	-14.75	46	30.41	29.25	3.43	32.02	-	-	P	V
	952.4	33.55	-12.45	46	29.88	31.04	3.64	31.26	-	-	P	V	
Remark	1. No other spurious found. 2. All results are PASS against limit line.												



<For WPC Charging Mode>

Band 4 - 5725~5850MHz
WIFI 802.11a (Band Edge @ 3m)

Table with 14 columns: WIFI Ant. 1+2, Note, Frequency (MHz), Level (dBµV/m), Over Limit (dB), Limit Line (dBµV/m), Read Level (dBµV), Antenna Factor (dB/m), Path Loss (dB), Preamp Factor (dB), Ant Pos (cm), Table Pos (deg), Peak Avg. (P/A), Pol. (H/V). Rows include frequency measurements from 5634.8 to 5745 MHz with various level and limit values.



Band 4 5725~5850MHz

WIFI 802.11a (Harmonic @ 3m)

WIFI Ant. 1+2	Note	Frequency (MHz)	Level (dBμV/m)	Over Limit (dB)	Limit Line (dBμV/m)	Read Level (dBμV)	Antenna Factor (dB/m)	Path Loss (dB)	Preamp Factor (dB)	Ant Pos (cm)	Table Pos (deg)	Peak Avg. (P/A)	Pol. (H/V)
802.11a CH 149 5745MHz		11490	53.76	-20.24	74	61.03	40.41	13.35	61.6	152	74	P	H
		11490	45.5	-8.5	54	52.77	40.41	13.35	61.6	152	74	A	H
		17235	52.22	-15.98	68.2	48.42	41.71	17.43	55.79	100	0	P	H
		11490	57.54	-16.46	74	64.81	40.41	13.35	61.6	100	355	P	V
		11490	49.76	-4.24	54	57.03	40.41	13.35	61.6	100	355	A	V
		17235	54.97	-13.23	68.2	51.17	41.71	17.43	55.79	100	0	P	V



Emission below 1GHz
5GHz WIFI 802.11a (LF @ 3m)

Table with 14 columns: WIFI, Note, Frequency, Level, Over, Limit, Read, Antenna, Path, Preamp, Ant, Table, Peak, Pol. It contains 12 rows of test data for 5GHz WIFI 802.11a LF and a Remark section at the bottom.



Note symbol

*	Fundamental Frequency which can be ignored. However, the level of any unwanted emissions shall not exceed the level of the fundamental frequency.
!	Test result is over limit line.
P/A	Peak or Average
H/V	Horizontal or Vertical



A calculation example for radiated spurious emission is shown as below:

WIFI	Note	Frequency	Level	Over	Limit	Read	Antenna	Path	Preamp	Ant	Table	Peak	Pol.
Ant.				Limit	Line	Level	Factor	Loss	Factor	Pos	Pos	Avg.	
1+2		(MHz)	(dBμV/m)	(dB)	(dBμV/m)	(dBμV)	(dB/m)	(dB)	(dB)	(cm)	(deg)	(P/A)	(H/V)
802.11b		2390	55.45	-18.55	74	54.51	32.22	4.58	35.86	103	308	P	H
CH 01													
2412MHz		2390	43.54	-10.46	54	42.6	32.22	4.58	35.86	103	308	A	H

1. Path Loss(dB) = Cable loss(dB) + Filter loss(dB) + Attenuator loss(dB)
2. Level(dBμV/m) = Antenna Factor(dB/m) + Path Loss(dB) + Read Level(dBμV) - Preamp Factor(dB)
3. Over Limit(dB) = Level(dBμV/m) – Limit Line(dBμV/m)

For Peak Limit @ 2390MHz:

1. Level(dBμV/m)
= Antenna Factor(dB/m) + Path Loss(dB) + Read Level(dBμV) - Preamp Factor(dB)
= 32.22(dB/m) + 4.58(dB) + 54.51(dBμV) – 35.86 (dB)
= 55.45 (dBμV/m)
2. Over Limit(dB)
= Level(dBμV/m) – Limit Line(dBμV/m)
= 55.45(dBμV/m) – 74(dBμV/m)
= -18.55(dB)

For Average Limit @ 2390MHz:

1. Level(dBμV/m)
= Antenna Factor(dB/m) + Path Loss(dB) + Read Level(dBμV) - Preamp Factor(dB)
= 32.22(dB/m) + 4.58(dB) + 42.6(dBμV) – 35.86 (dB)
= 43.54 (dBμV/m)
2. Over Limit(dB) = Level(dBμV/m) – Limit Line(dBμV/m)
= 43.54(dBμV/m) – 54(dBμV/m)
= -10.46(dB)

Both peak and average measured complies with the limit line, so test result is “PASS”.



Appendix D. Radiated Spurious Emission Plots

Test Engineer :	Bill Chang, Karl Hou, and Lance Chiang	Temperature :	24~26°C
		Relative Humidity :	50~54%

Note symbol

-L	Low channel location
-R	High channel location



Band 4 - 5725~5850MHz
WIFI 802.11a (Band Edge @ 3m)

WIFI	Band 4 5725~5850MHz Band Edge @ 3m	
ANT	802.11a CH149 5745MHz	
1+2	Horizontal	Fundamental
Peak	<p>Site : 03CH15-HY Condition : PEAK_8E(84)_16-24 3m 91200_15_1620 HORIZONTAL Detector : Peak Project : 820502-02 Mode : 36</p>	<p>Site : 03CH15-HY Condition : PEAK(LINE) 3m 91200_15_1620 HORIZONTAL Detector : Peak Project : 820502-02 Mode : 36</p>

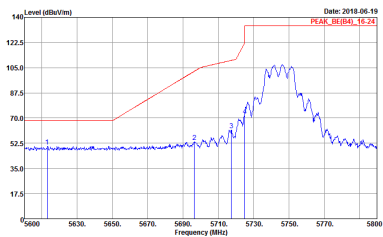
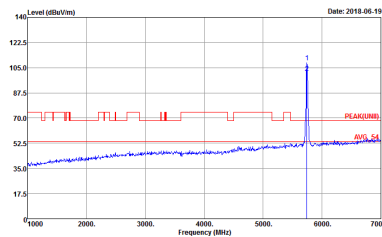

WIFI	Band 4 5725~5850MHz Band Edge @ 3m	
ANT	802.11a CH149 5745MHz	
1+2	Vertical	Fundamental
Peak	 <p>Site : 03CH15-11Y Condition : PEAK_BE(B4)_16-24 3m 91200_15_1620 VERTICAL Detector : Peak Project : 820502-02 Mode : 36</p>	 <p>Site : 03CH15-11Y Condition : PEAK(LINII) 3m 91200_15_1620 VERTICAL Detector : Peak Project : 820502-02 Mode : 36</p>



WIFI	Band 4 5725~5850MHz Band Edge @ 3m	
ANT	802.11a CH157 5785MHz	
1+2	Horizontal	Fundamental
<p>Peak</p>	<p>Site : 03CH15-HY Condition : PEAK_BE(84)_16-24 3m 91200_15_1620 HORIZONTAL Detector : Peak Project : 820502-02 Mode : 37</p>	<p>Site : 03CH15-HY Condition : PEAK(LINII) 3m 91200_15_1620 HORIZONTAL Detector : Peak Project : 820502-02 Mode : 37</p>
<p>Peak</p>	<p>Site : 03CH15-HY Condition : PEAK_BE(84)_16-24 3m 91200_15_1620 HORIZONTAL Detector : Peak Project : 820502-02 Mode : 37</p>	<p>Left blank</p>



WIFI	Band 4 5725-5850MHz Band Edge @ 3m	
ANT	802.11a CH157 5785MHz	
1+2	Vertical	Fundamental
Peak	<p>Site : 03CH15-HY Condition : PEAK_BE(B4)_16-24 3m 91200_15_1620 VERTICAL Detector : Peak Project : 820502-02 Mode : 37</p>	<p>Site : 03CH15-HY Condition : PEAK(LINB) 3m 91200_15_1620 VERTICAL Detector : Peak Project : 820502-02 Mode : 37</p>
Peak	<p>Site : 03CH15-HY Condition : PEAK_BE(B4)_16-24 3m 91200_15_1620 VERTICAL Detector : Peak Project : 820502-02 Mode : 37</p>	Left blank

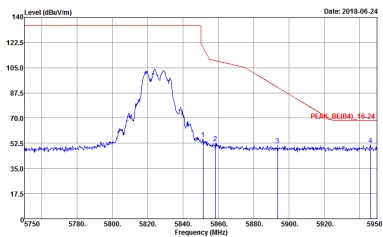
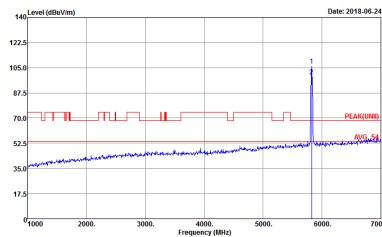

WIFI	Band 4 5725~5850MHz Band Edge @ 3m	
ANT	802.11a CH165 5825MHz	
1+2	Horizontal	Fundamental
Peak	 <p>Site : 03CH15-11Y Condition : PEAK_BE(B4)_16-24 3m 91200_15_1620 HORIZONTAL Detector : Peak Project : 820502-02 Mode : 3B</p>	 <p>Site : 03CH15-11Y Condition : PEAK(LINII) 3m 91200_15_1620 HORIZONTAL Detector : Peak Project : 820502-02 Mode : 3B</p>

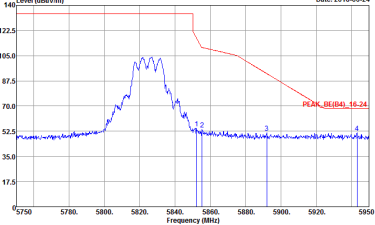
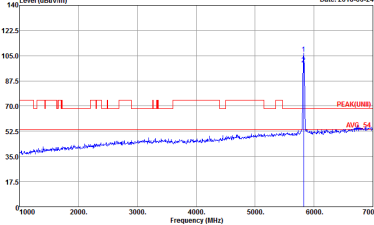

WIFI	Band 4 5725~5850MHz Band Edge @ 3m	
ANT	802.11a CH165 5825MHz	
1+2	Vertical	Fundamental
Peak	 <p>Site : 03CH15-11Y Condition : PEAK_BE(B4)_16-24 3m 91200_15_1620 VERTICAL Detector : Peak Project : 820502-02 Mode : 3B</p>	 <p>Site : 03CH15-11Y Condition : PEAK(LINII) 3m 91200_15_1620 VERTICAL Detector : Peak Project : 820502-02 Mode : 3B</p>



**Band 4 5725~5850MHz
WIFI 802.11n HT20 (Band Edge @ 3m)**

WIFI	Band 4 5725~5850MHz Band Edge @ 3m	
ANT	802.11n HT20 CH149 5745MHz	
1+2	Horizontal	Fundamental
Peak	<p>Site : 03CH15-HY Condition : PEAK_BE(84)_16-24 3m 91200_15_1620 HORIZONTAL Detector : Peak Project : 820502-02 Mode : 39</p>	<p>Site : 03CH15-HY Condition : PEAK(UNIT) 3m 91200_15_1620 HORIZONTAL Detector : Peak Project : 820502-02 Mode : 39</p>

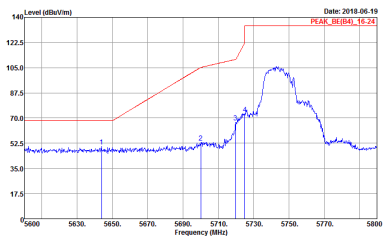
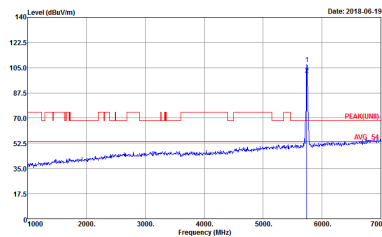

WIFI	Band 4 5725~5850MHz Band Edge @ 3m	
ANT	802.11n HT20 CH149 5745MHz	
1+2	Vertical	Fundamental
Peak	 <p>Date: 2018.06.19 PEAK_BE(B4)_16-24</p> <p>Site : 03CH15-11Y Condition : PEAK_BE(B4)_16-24 3m 91200_15_1620 VERTICAL Detector : RBW:1000.000KHz VBW:3000.000KHz SWT:Auto Project : 820502-02 Mode : 39</p>	 <p>Date: 2018.06.19 PEAK(LINB) AVG 51</p> <p>Site : 03CH15-11Y Condition : PEAK(LINB)_3m 91200_15_1620 VERTICAL Detector : RBW:1000.000KHz VBW:3000.000KHz SWT:Auto Project : 820502-02 Mode : 39</p>

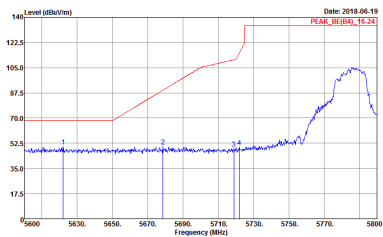
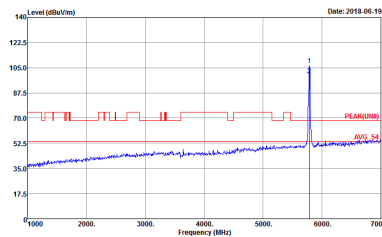
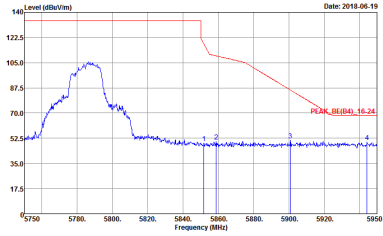

WIFI	Band 4 5725-5850MHz Band Edge @ 3m	
ANT	802.11n HT20 CH157 5785MHz	
1+2	Horizontal	Fundamental
<p>Peak</p>	 <p>Site : 03CH15-HY Condition : PEAK_BE(84)_16-24 3m 91200_15_1620 HORIZONTAL Detector : Peak Project : 820502-02 Mode : 40</p>	 <p>Site : 03CH15-HY Condition : PEAK(LINII) 3m 91200_15_1620 HORIZONTAL Detector : Peak Project : 820502-02 Mode : 40</p>
<p>Peak</p>	 <p>Site : 03CH15-HY Condition : PEAK_BE(84)_16-24 3m 91200_15_1620 HORIZONTAL Detector : Peak Project : 820502-02 Mode : 40</p>	<p>Left blank</p>

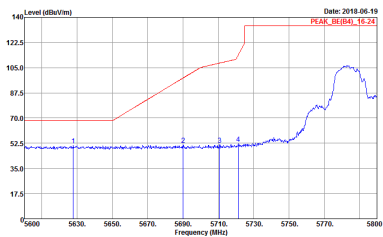
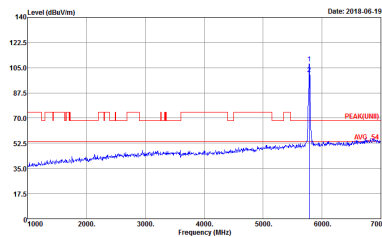
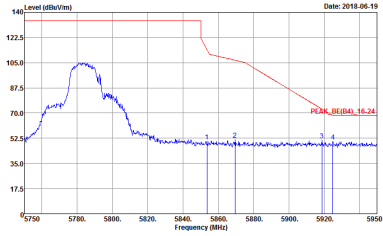

WIFI	Band 4 5725~5850MHz Band Edge @ 3m	
ANT	802.11n HT20 CH157 5785MHz	
1+2	Vertical	Fundamental
<p>Peak</p>	 <p>Site : 03CH15-HY Condition : PEAK_BE(84)_16-24 3m 91200_15_1620 VERTICAL Detector : Peak Project : 820502-02 Mode : 40</p>	 <p>Site : 03CH15-HY Condition : PEAK(LINII) 3m 91200_15_1620 VERTICAL Detector : Peak Project : 820502-02 Mode : 40</p>
<p>Peak</p>	 <p>Site : 03CH15-HY Condition : PEAK_BE(84)_16-24 3m 91200_15_1620 VERTICAL Detector : Peak Project : 820502-02 Mode : 40</p>	<p>Left blank</p>

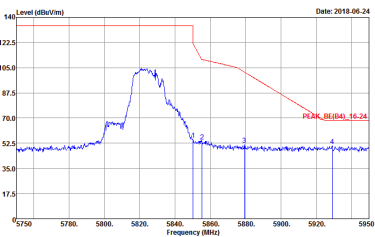
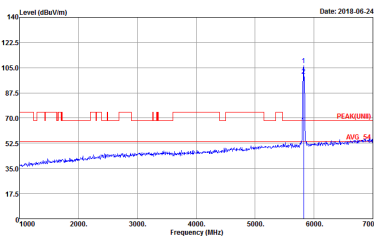

WIFI	Band 4 5725~5850MHz Band Edge @ 3m	
ANT	802.11n HT20 CH165 5825MHz	
1+2	Horizontal	Fundamental
Peak	 <p>Site : 03CH15-11Y Condition : PEAK_BE(B4)_16-24 3m 91200_15_1620 HORIZONTAL Detector : Peak Project : 820502-02 Mode : 41</p>	 <p>Site : 03CH15-11Y Condition : PEAK(LINII) 3m 91200_15_1620 HORIZONTAL Detector : Peak Project : 820502-02 Mode : 41</p>

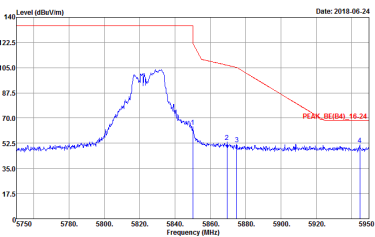
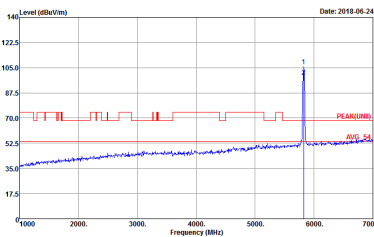

WIFI	Band 4 5725~5850MHz Band Edge @ 3m	
ANT	802.11n HT20 CH165 5825MHz	
1+2	Vertical	Fundamental
Peak	 <p>Site : 03CH15-11Y Condition : PEAK_BE(B4)_16-24 3m 91200_15_1620 VERTICAL Detector : Peak Project : 820502-02 Mode : 41</p>	 <p>Site : 03CH15-11Y Condition : PEAK(LINII) 3m 91200_15_1620 VERTICAL Detector : Peak Project : 820502-02 Mode : 41</p>



**Band 4 5725~5850MHz
WIFI 802.11n HT40 (Band Edge @ 3m)**

WIFI	Band 4 5725~5850MHz Band Edge @ 3m	
ANT	802.11n HT40 CH151 5755MHz	
1+2	Horizontal	Fundamental
Peak	<p>Site : 03CH15-HY Condition : PEAK_BE(B4)_16-24 3m 91200_15_1620 HORIZONTAL Detector : Peak Project : 820502-02 Mode : 42</p>	<p>Site : 03CH15-HY Condition : PEAK(UNIT) 3m 91200_15_1620 HORIZONTAL Detector : Peak Project : 820502-02 Mode : 42</p>
Peak	<p>Site : 03CH15-HY Condition : PEAK_BE(B4)_16-24 3m 91200_15_1620 HORIZONTAL Detector : Peak Project : 820502-02 Mode : 42</p>	Left blank

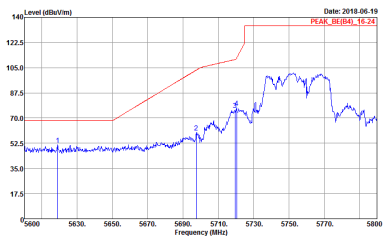
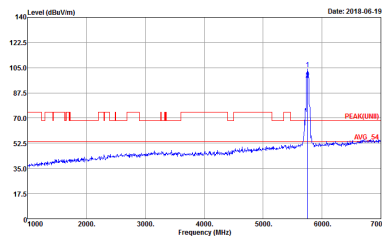
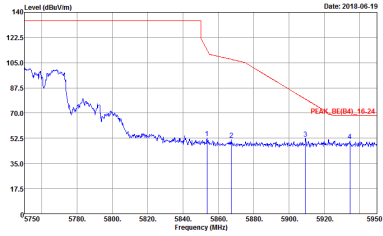

WIFI	Band 4 5725-5850MHz Band Edge @ 3m	
ANT	802.11n HT40 CH151 5755MHz	
1+2	Vertical	Fundamental
<p>Peak</p>	 <p>Site : 03CH15-HY Condition : PEAK_BE(B4)_16-24 3m 91200_15_1620 VERTICAL Detector : Peak Project : 820502-02 Mode : 42</p>	 <p>Site : 03CH15-HY Condition : PEAK(LINII) 3m 91200_15_1620 VERTICAL Detector : Peak Project : 820502-02 Mode : 42</p>
<p>Peak</p>	 <p>Site : 03CH15-HY Condition : PEAK_BE(B4)_16-24 3m 91200_15_1620 VERTICAL Detector : Peak Project : 820502-02 Mode : 42</p>	<p>Left blank</p>

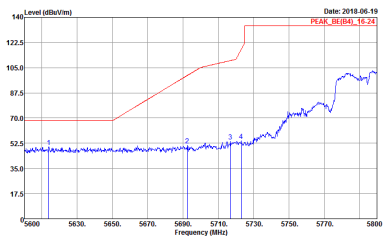
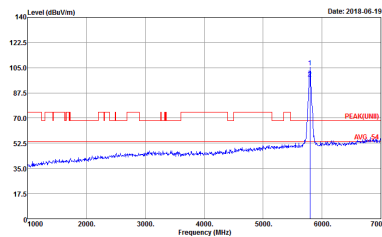
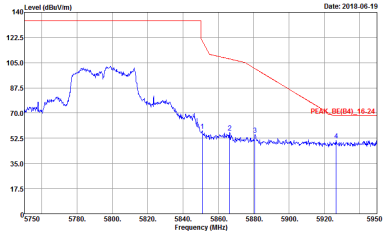

WIFI	Band 4 5725-5850MHz Band Edge @ 3m	
ANT	802.11n HT40 CH159 5795MHz	
1+2	Horizontal	Fundamental
Peak	 <p>Site : 03CH15-HY Condition : PEAK_BE(B4)_16-24 3m 91200_15_1620 HORIZONTAL RBW:1000.000KHz VBW:3000.000KHz SWT:Auto Detector : Peak Project : 820502-02 Mode : 43</p>	 <p>Site : 03CH15-HY Condition : PEAK(LINII) 3m 91200_15_1620 HORIZONTAL RBW:1000.000KHz VBW:3000.000KHz SWT:Auto Detector : Peak Project : 820502-02 Mode : 43</p>
Peak	 <p>Site : 03CH15-HY Condition : PEAK_BE(B4)_16-24 3m 91200_15_1620 HORIZONTAL RBW:1000.000KHz VBW:3000.000KHz SWT:Auto Detector : Peak Project : 820502-02 Mode : 43</p>	Left blank



WIFI	Band 4 5725-5850MHz Band Edge @ 3m	
ANT	802.11n HT40 CH159 5795MHz	
1+2	Vertical	Fundamental
<p>Peak</p>	<p>Site : 03CH15-HY Condition : PEAK_BE(84)_16-24 3m 91200_15_1620 VERTICAL Detector : Peak Project : 820502-02 Mode : 43</p>	<p>Site : 03CH15-HY Condition : PEAK(LINII) 3m 91200_15_1620 VERTICAL Detector : Peak Project : 820502-02 Mode : 43</p>
<p>Peak</p>	<p>Site : 03CH15-HY Condition : PEAK_BE(84)_16-24 3m 91200_15_1620 VERTICAL Detector : Peak Project : 820502-02 Mode : 43</p>	<p>Left blank</p>



**Band 4 5725~5850MHz
WIFI 802.11ac VHT80 (Band Edge @ 3m)**

WIFI	Band 4 5725~5850MHz Band Edge @ 3m	
ANT	802.11ac VHT80 CH155 5775MHz	
1+2	Horizontal	Fundamental
Peak	<p>Site : 03CH15-HY Condition : PEAK_BE(B4)_16-24 3m 91200_15_1620 HORIZONTAL Detector : Peak Project : 820502-02 Mode : 44</p>	<p>Site : 03CH15-HY Condition : PEAK(UNIT) 3m 91200_15_1620 HORIZONTAL Detector : Peak Project : 820502-02 Mode : 44</p>
Peak	<p>Site : 03CH15-HY Condition : PEAK_BE(B4)_16-24 3m 91200_15_1620 HORIZONTAL Detector : Peak Project : 820502-02 Mode : 44</p>	Left blank



WIFI	Band 4 5725~5850MHz Band Edge @ 3m	
ANT	802.11ac VHT80 CH155 5775MHz	
1+2	Vertical	Fundamental
<p>Peak</p>	<p>Site : 03CH15-HY Condition : PEAK_BE(B4)_16-24 3m 91200_15_1620 VERTICAL Detector : Peak Project : 820502-02 Mode : 44</p>	<p>Site : 03CH15-HY Condition : PEAK(LINB) 3m 91200_15_1620 VERTICAL Detector : Peak Project : 820502-02 Mode : 44</p>
<p>Peak</p>	<p>Site : 03CH15-HY Condition : PEAK_BE(B4)_16-24 3m 91200_15_1620 VERTICAL Detector : Peak Project : 820502-02 Mode : 44</p>	<p>Left blank</p>



Band 4 - 5725~5850MHz
WIFI 802.11a (Harmonic @ 3m)

Table with 2 columns: Horizontal and Vertical. Each column contains a spectral plot of Level (dBV/m) vs Frequency (MHz) with peak and average values indicated. Includes metadata like Site, Condition, Detector, Project, and Mode.

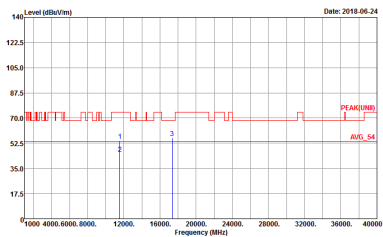
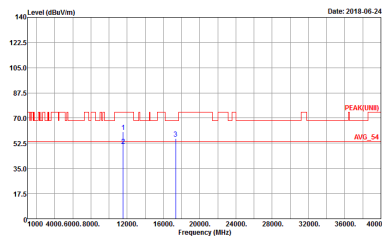

WIFI	Band 4 5725~5850MHz Harmonic @ 3m	
ANT	802.11a CH157 5785MHz	
1+2	Horizontal	Vertical
<p>Peak</p> <p>Avg.</p>	 <p>Site : 03CH15-11Y Condition : PEAK(LINE) 3m 9120D_15_1620 HORIZONTAL Detector : Peak Project : 820502-02 Mode : 37 Setting : 17</p>	 <p>Site : 03CH15-11Y Condition : PEAK(LINE) 3m 9120D_15_1620 VERTICAL Detector : Peak Project : 820502-02 Mode : 37 Setting : 17</p>

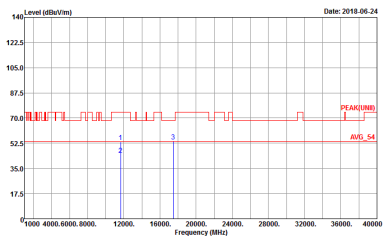
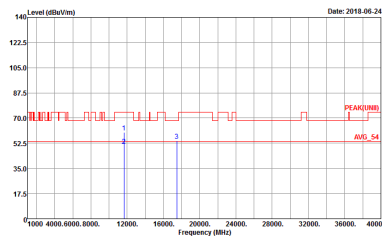

WIFI	Band 4 5725~5850MHz Harmonic @ 3m	
ANT	802.11a CH165 5825MHz	
1+2	Horizontal	Vertical
<p>Peak</p> <p>Avg.</p>	 <p>Site : 03CH15-11Y Condition : PEAK(LINEI) 3m 9120D_15_1620 HORIZONTAL Detector : Peak Project : 820502-02 Mode : 38 Setting : 16.5</p>	 <p>Site : 03CH15-11Y Condition : PEAK(LINEI) 3m 9120D_15_1620 VERTICAL Detector : Peak Project : 820502-02 Mode : 38 Setting : 16.5</p>



**Band 4 5725~5850MHz
WIFI 802.11n HT20 (Harmonic @ 3m)**

WIFI	Band 4 5725~5850MHz Harmonic @ 3m	
ANT	802.11n HT20 CH149 5745MHz	
1+2	Horizontal	Vertical
Peak Avg.	<p>Site : 03CH15-HY Condition : PEAK(UNIT) 3m 91200_15_1620 HORIZONTAL Detector : Peak Project : 820502-02 Mode : 39</p>	<p>Site : 03CH15-HY Condition : PEAK(UNIT) 3m 91200_15_1620 VERTICAL Detector : Peak Project : 820502-02 Mode : 39</p>

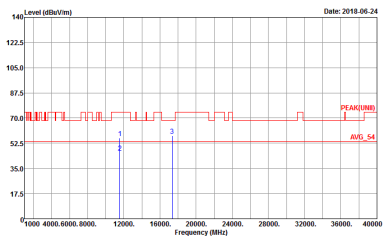
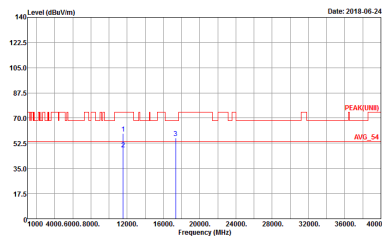

WIFI	Band 4 5725~5850MHz Harmonic @ 3m	
ANT	802.11n HT20 CH157 5785MHz	
1+2	Horizontal	Vertical
<p>Peak</p> <p>Avg.</p>	 <p>Site : 03CH15-11Y Condition : PEAK(LINE) 3m 9120D_15_1620 HORIZONTAL Detector : Peak Project : 820502-02 Mode : -40</p>	 <p>Site : 03CH15-11Y Condition : PEAK(LINE) 3m 9120D_15_1620 VERTICAL Detector : Peak Project : 820502-02 Mode : -40</p>

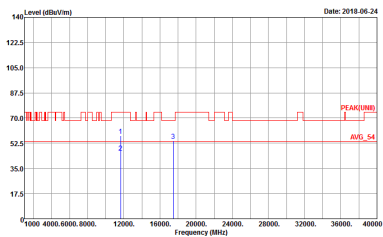
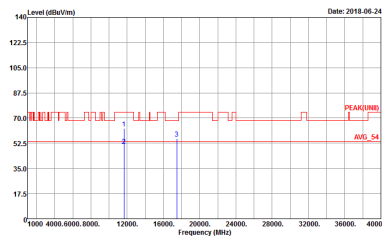

WIFI	Band 4 5725~5850MHz Harmonic @ 3m	
ANT	802.11n HT20 CH165 5825MHz	
1+2	Horizontal	Vertical
<p>Peak</p> <p>Avg.</p>	 <p>Site : 03CH15-11Y Condition : PEAK(LINEI) 3m 9120D_15_1620 HORIZONTAL Detector : Peak Project : 820502-02 Mode : 41 Setting : 17.5</p>	 <p>Site : 03CH15-11Y Condition : PEAK(LINEI) 3m 9120D_15_1620 VERTICAL Detector : Peak Project : 820502-02 Mode : 41 Setting : 17.5</p>



**Band 4 5725~5850MHz
WIFI 802.11n HT40 (Harmonic @ 3m)**

WIFI	Band 4 5725~5850MHz Harmonic @ 3m	
ANT	802.11n HT40 CH151 5755MHz	
1+2	Horizontal	Vertical
Peak Avg.	<p>Site : 03CH15-HY Condition : PEAK(UNIT) 3m 91200_15_1620 HORIZONTAL Detector : Peak Project : 820502-02 Mode : 42</p>	<p>Site : 03CH15-HY Condition : PEAK(UNIT) 3m 91200_15_1620 VERTICAL Detector : Peak Project : 820502-02 Mode : 42</p>



WIFI	Band 4 5725~5850MHz Harmonic @ 3m	
ANT	802.11n HT40 CH159 5795MHz	
1+2	Horizontal	Vertical
Peak Avg.	<p>Site : 03CH15-11Y Condition : PEAK(LINE) 3m 91200_15_1620 HORIZONTAL Detector : Peak Project : 820502-02 Mode : -43</p>	<p>Site : 03CH15-11Y Condition : PEAK(LINE) 3m 91200_15_1620 VERTICAL Detector : Peak Project : 820502-02 Mode : -43</p>



**Band 4 5725~5850MHz
WIFI 802.11ac VHT80 (Harmonic @ 3m)**

WIFI	Band 4 5725~5850MHz Harmonic @ 3m	
ANT	802.11ac VHT80 CH155 5775MHz	
1+2	Horizontal	Vertical
Peak Avg.	<p>Site : 03CH15-HY Condition : PEAK(UNIT) 3m 91200_15_1620 HORIZONTAL Detector : Peak Project : 820502-02 Mode : 44</p>	<p>Site : 03CH15-HY Condition : PEAK(UNIT) 3m 91200_15_1620 VERTICAL Detector : Peak Project : 820502-02 Mode : 44</p>



Emission below 1GHz
5GHz WIFI 802.11ac VHT80 (LF)

WIFI	5GHz 5725~5850MHz	
ANT	802.11ac VHT80 LF	
1+2	Horizontal	Vertical
QP / Peak	<p>Site : 03CH15-HY Condition : QP 3m BTL06_15_41912 HORIZONTAL Detector : Peak Project : 820502-02 Mode : 45</p>	<p>Site : 03CH15-HY Condition : QP 3m BTL06_15_41912 VERTICAL Detector : Peak Project : 820502-02 Mode : 45</p>



<For WPC Charging Mode>

Band 4 - 5725~5850MHz
WIFI 802.11a (Band Edge @ 3m)

WIFI	Band 4 5725~5850MHz Band Edge @ 3m	
ANT	802.11a CH149 5745MHz	
1+2	Horizontal	Fundamental
Peak	<p>Site : 03CH15-HY Condition : PEAK_BE(34)_16-24 3m 91200_15_1620 HORIZONTAL RBW:1000.000KHz VBW:3000.000KHz SWT:Auto Detector : Peak Project : 820502-02 Mode : 46</p>	<p>Site : 03CH15-HY Condition : PEAK(LINE) 3m 91200_15_1620 HORIZONTAL RBW:1000.000KHz VBW:3000.000KHz SWT:Auto Detector : Peak Project : 820502-02 Mode : 46</p>

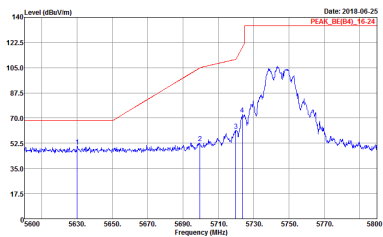
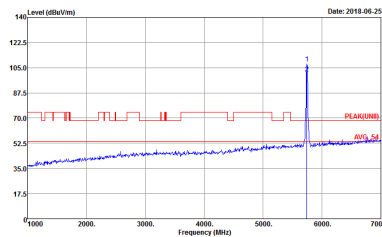

WIFI	Band 4 5725~5850MHz Band Edge @ 3m	
ANT	802.11a CH149 5745MHz	
1+2	Vertical	Fundamental
Peak	 <p>Date: 2018.06.25 PEAK_BE(B4)_16-24</p> <p>Site : 03CH15-11Y Condition : PEAK_BE(B4)_16-24 3m 91200_15_1620 VERTICAL Detector : Peak Project : 820502-02 Mode : 46</p>	 <p>Date: 2018.06.25 PEAK(LINB) AVG-55</p> <p>Site : 03CH15-11Y Condition : PEAK(LINB)_3m 91200_15_1620 VERTICAL Detector : Peak Project : 820502-02 Mode : 46</p>



Band 4 - 5725~5850MHz
WIFI 802.11a (Harmonic @ 3m)

WIFI	Band 4 5725~5850MHz Harmonic @ 3m	
ANT	802.11a CH149 5745MHz	
1+2	Horizontal	Vertical
Peak Avg.	<p>Site : 03CH15-HY Condition : PEAK(LINE) 3m 91200_15_1620 HORIZONTAL Detector : Peak Project : 820502-02 Mode : 46</p>	<p>Site : 03CH15-HY Condition : PEAK(LINE) 3m 91200_15_1620 VERTICAL Detector : Peak Project : 820502-02 Mode : 46</p>



Emission below 1GHz
5GHz WIFI 802.11a (LF)

WIFI	5GHz 5725~5850MHz	
ANT	802.11a LF	
1+2	Horizontal	Vertical
QP / Peak	<p>Site : 03CH15-HY Condition : QP 3m B1LOG_15_41912 HORIZONTAL Detector : Peak Project : 820502-02 Mode : 46</p>	<p>Site : 03CH15-HY Condition : QP 3m B1LOG_15_41912 VERTICAL Detector : Peak Project : 820502-02 Mode : 46</p>



Appendix E. Duty Cycle Plots

Antenna	Band	Duty Cycle(%)	T(us)	1/T(kHz)	VBW Setting	Duty Factor(dB)
1	802.11a	97.73	2064.00	0.48	1kHz	0.10
2	802.11a	97.73	2064.00	0.48	1kHz	0.10
1+2	802.11a for Antenna 1	97.73	2064.00	0.48	1kHz	0.10
1+2	802.11a for Antenna 2	97.73	2064.00	0.48	1kHz	0.10
1	5GHz 802.11n HT20	97.56	1920.00	0.52	1kHz	0.11
2	5GHz 802.11n HT20	97.56	1920.00	0.52	1kHz	0.00
1+2	5GHz 802.11n HT20 for Antenna 1	97.56	1920.00	0.52	1kHz	0.11
1+2	5GHz 802.11n HT20 for Antenna 2	97.56	1920.00	0.52	1kHz	0.11
1	5GHz 802.11n HT40	95.93	944.00	1.06	3kHz	0.18
2	5GHz 802.11n HT40	95.93	944.00	1.06	3kHz	0.18
1+2	5GHz 802.11n HT40 for Antenna 1	95.16	944.00	1.06	3kHz	0.22
1+2	5GHz 802.11n HT40 for Antenna 2	95.93	944.00	1.06	3kHz	0.18
1	5GHz 802.11ac VHT20	97.58	1936.00	0.52	1kHz	0.11
2	5GHz 802.11ac VHT20	97.58	1936.00	0.52	1kHz	0.11
1+2	5GHz 802.11ac VHT20 for Antenna 1	97.56	1920.00	0.52	1kHz	0.11
1+2	5GHz 802.11ac VHT20 for Antenna 2	97.58	1936.00	0.52	1kHz	0.11
1	5GHz 802.11ac VHT40	95.97	952.00	1.05	3kHz	0.18
2	5GHz 802.11ac VHT40	95.93	944.00	1.06	3kHz	0.18
1+2	5GHz 802.11ac VHT40 for Antenna 1	95.97	952.00	1.05	3kHz	0.18
1+2	5GHz 802.11ac VHT40 for Antenna 2	95.93	944.00	1.06	3kHz	0.18
1	5GHz 802.11ac VHT80	92.00	460.00	2.17	3kHz	0.36
2	5GHz 802.11ac VHT80	91.63	460.00	2.17	3kHz	0.38
1+2	5GHz 802.11ac VHT80 for Antenna 1	92.00	460.00	2.17	3kHz	0.36
1+2	5GHz 802.11ac VHT80 for Antenna 2	91.20	460.00	2.17	3kHz	0.40



<Ant. 1>

802.11a

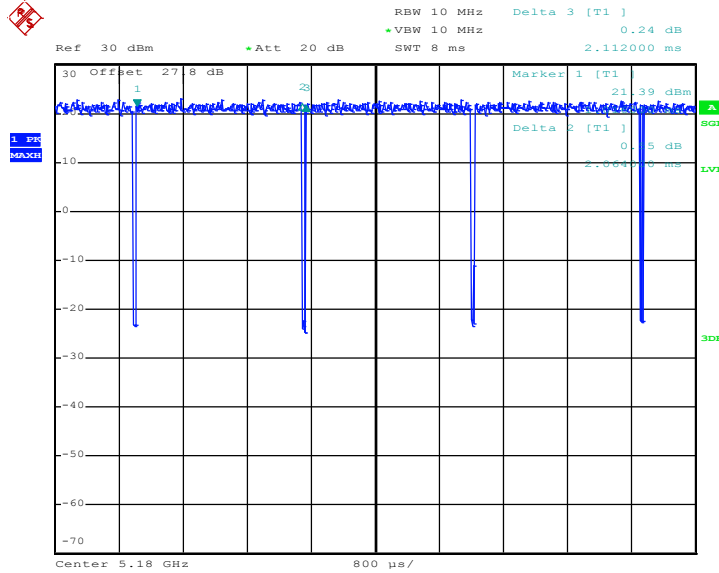

Date: 9.JUN.2018 00:13:56

802.11n HT20

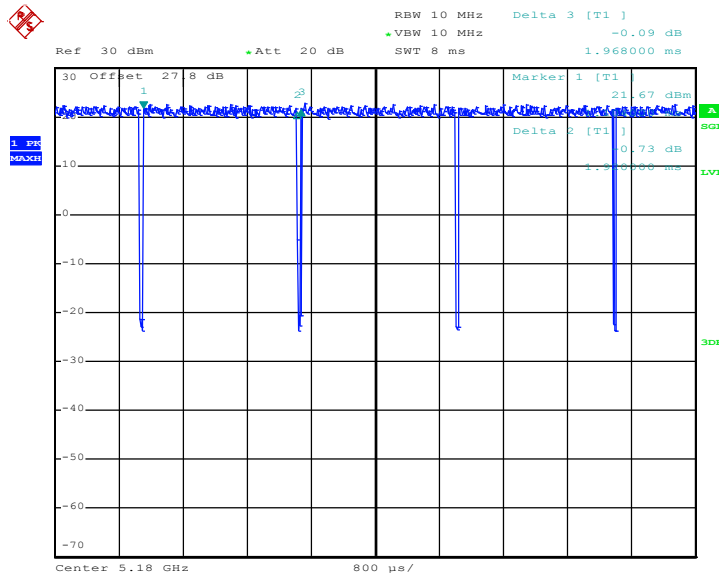

Date: 9.JUN.2018 00:33:12



802.11n HT40

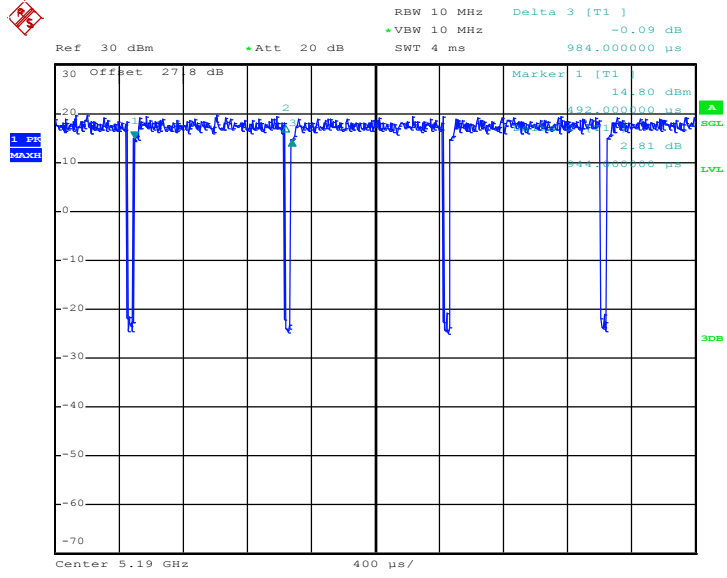

Date: 9.JUN.2018 00:47:06

802.11ac VHT20

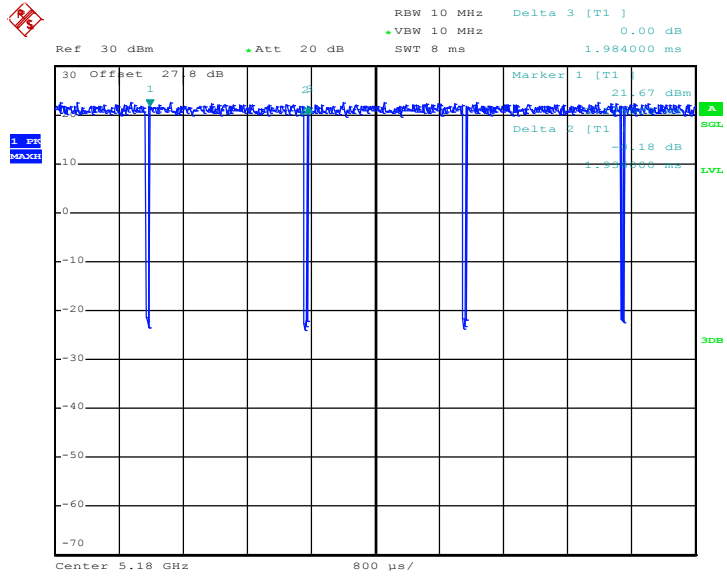

Date: 9.JUN.2018 00:56:12



802.11ac VHT40

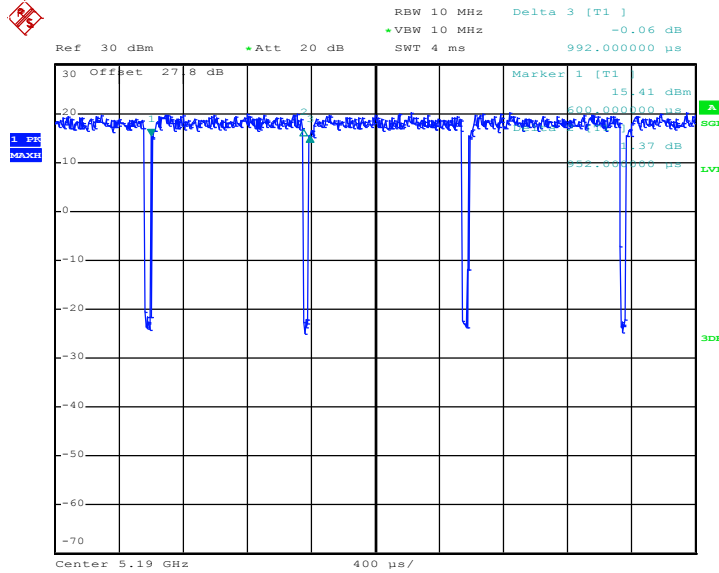

Date: 9.JUN.2018 01:07:04

802.11ac VHT80

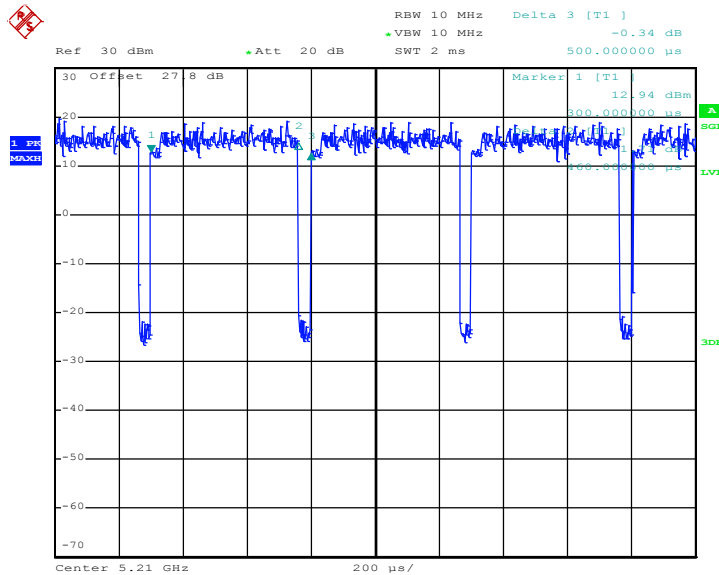

Date: 9.JUN.2018 01:15:59



<Ant. 2>

802.11a

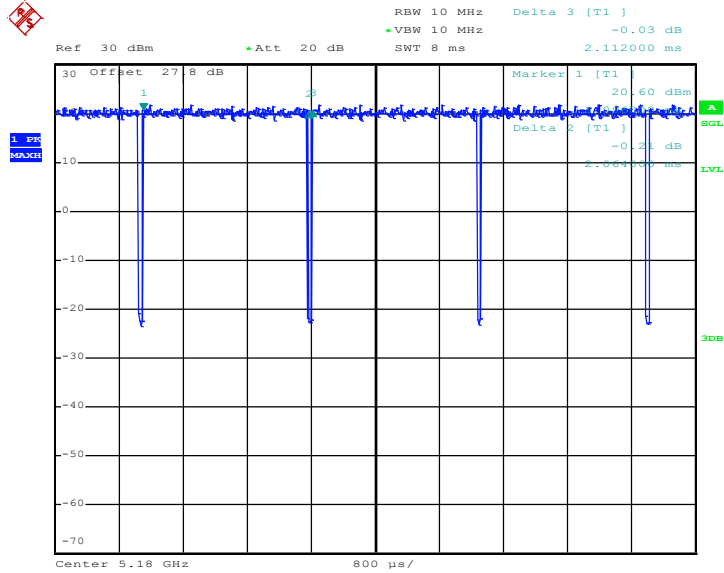

Date: 9.JUN.2018 00:16:20

802.11n HT20

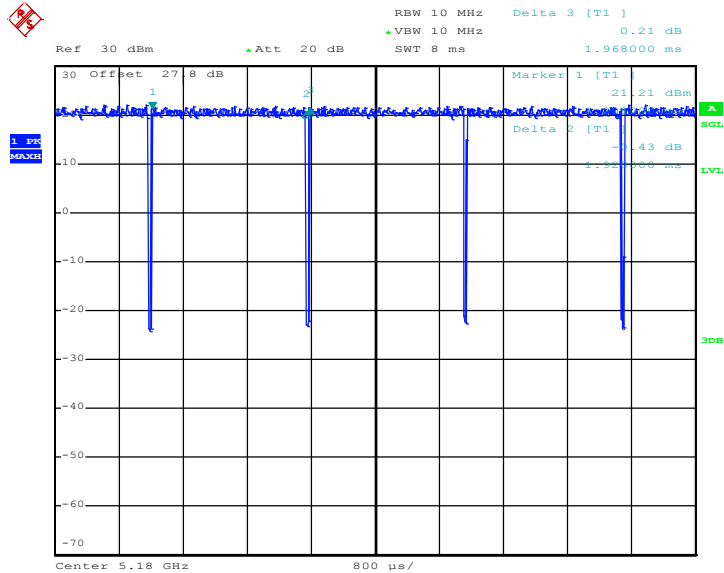

Date: 9.JUN.2018 00:34:46



802.11n HT40

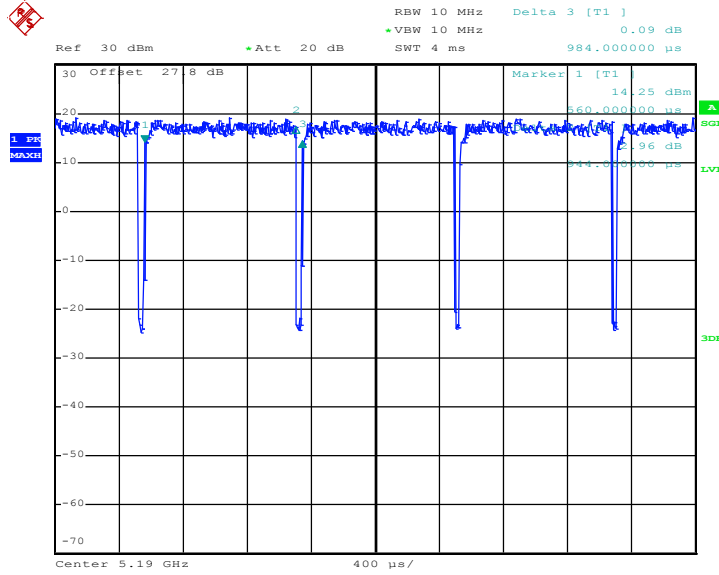

Date: 9.JUN.2018 00:48:28

802.11ac VHT20

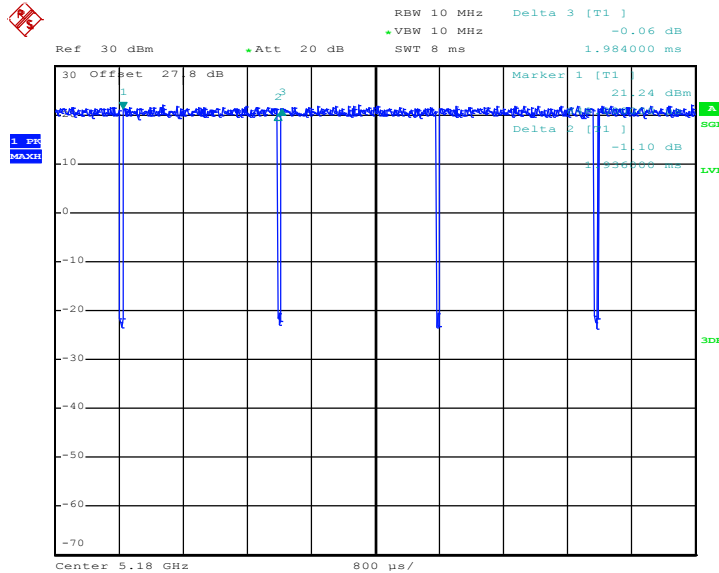

Date: 9.JUN.2018 00:57:34



802.11ac VHT40

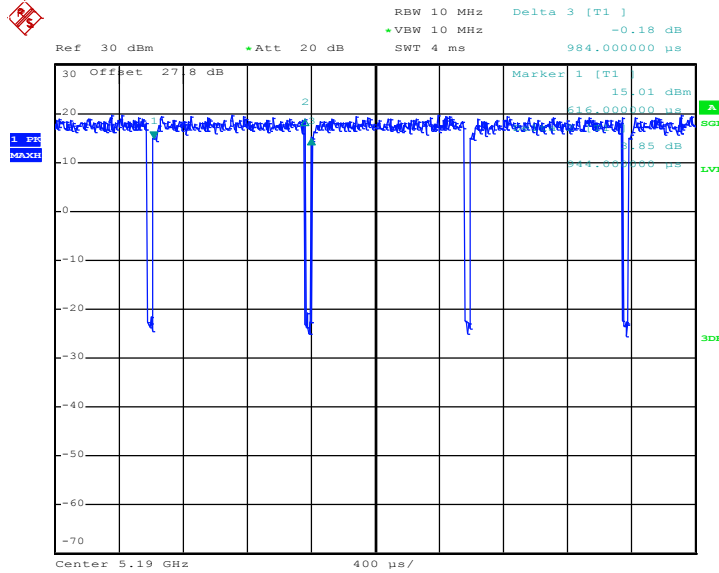

Date: 9.JUN.2018 01:09:00

802.11ac VHT80

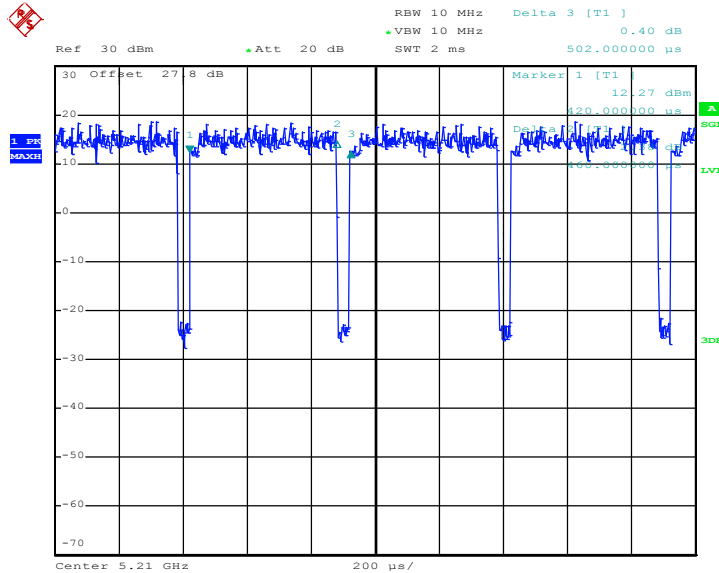

Date: 9.JUN.2018 01:18:22



MIMO <Ant. 1>

802.11a

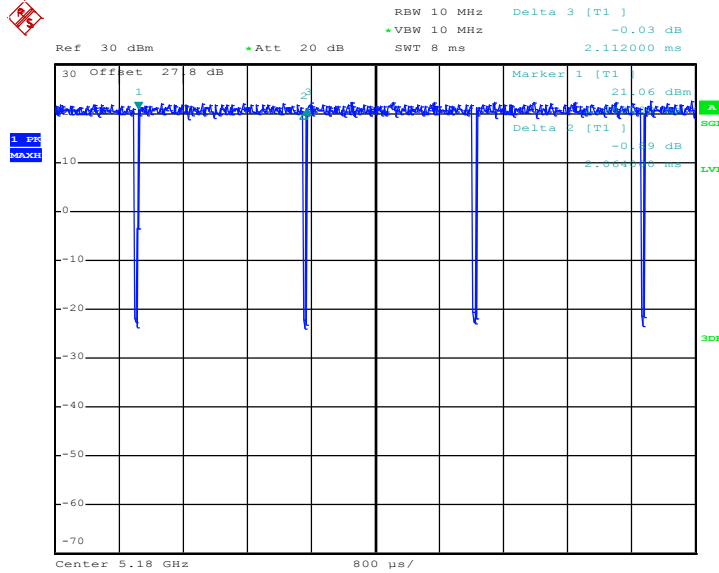

Date: 8.JUN.2018 23:18:12

802.11n HT20

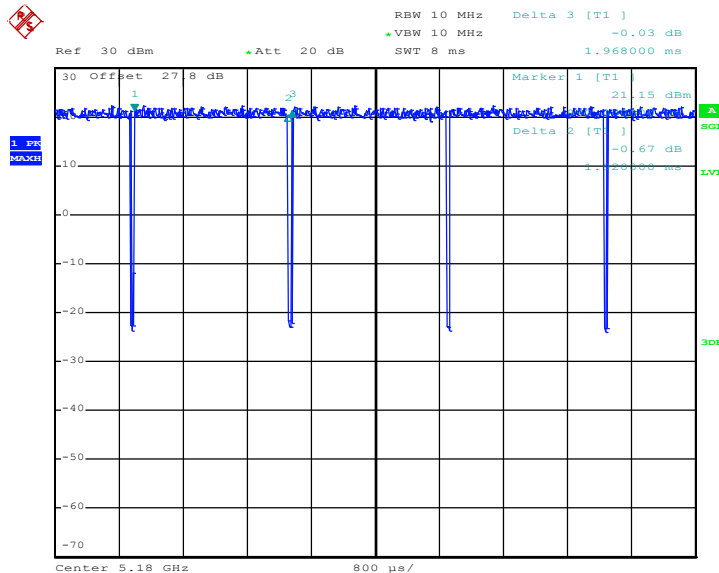

Date: 8.JUN.2018 23:21:19



802.11n HT40

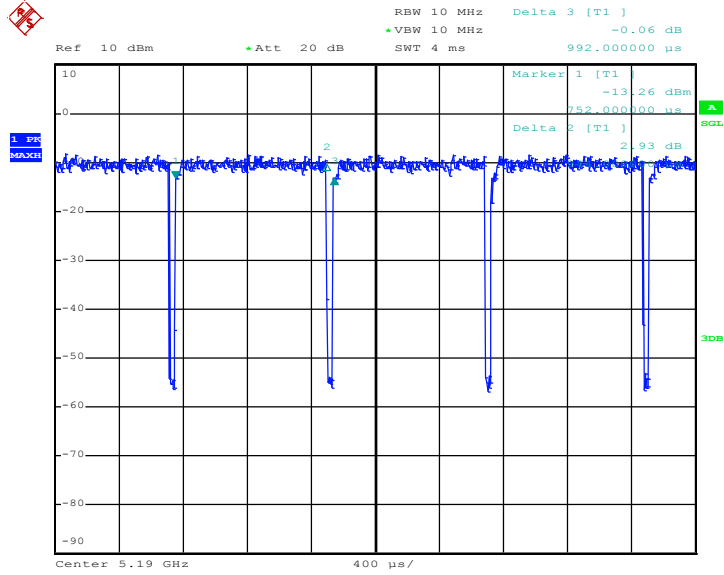

Date: 7.JUN.2018 03:27:04

802.11ac VHT20

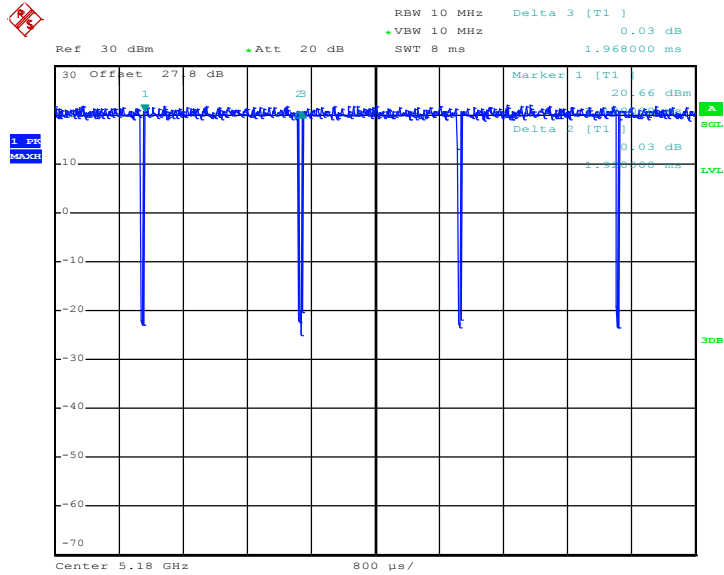

Date: 8.JUN.2018 23:56:44



802.11ac VHT40

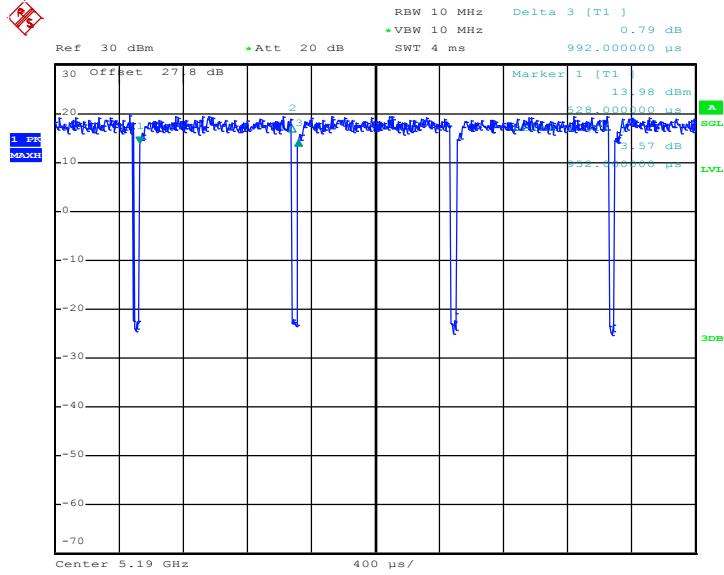

Date: 9.JUN.2018 00:05:27

802.11ac VHT80

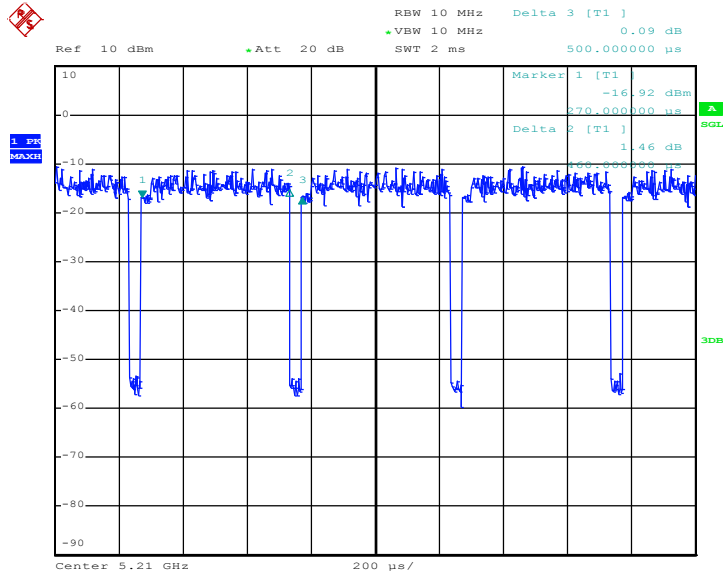

Date: 7.JUN.2018 03:40:10



MIMO <Ant. 2>

802.11a

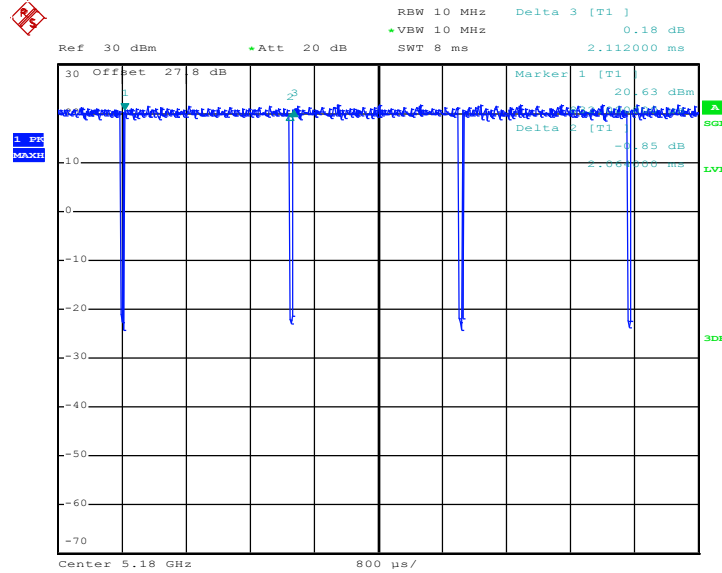

Date: 8.JUN.2018 23:19:12

802.11n HT20

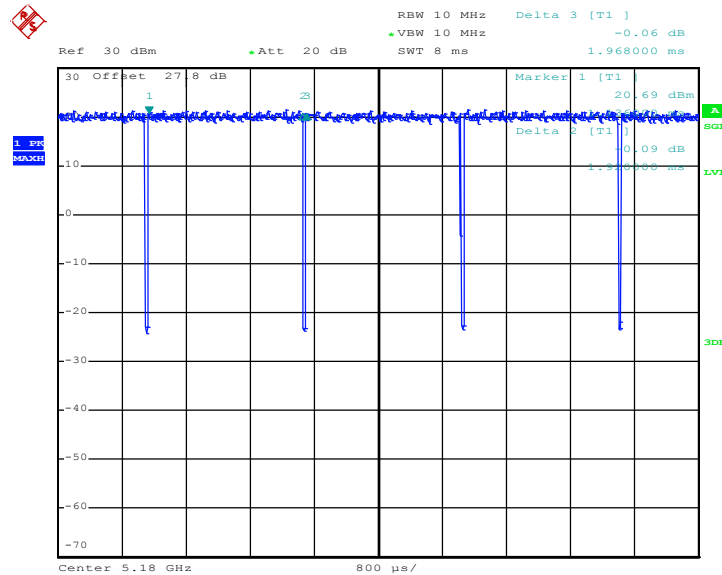

Date: 8.JUN.2018 23:22:08



802.11n HT40

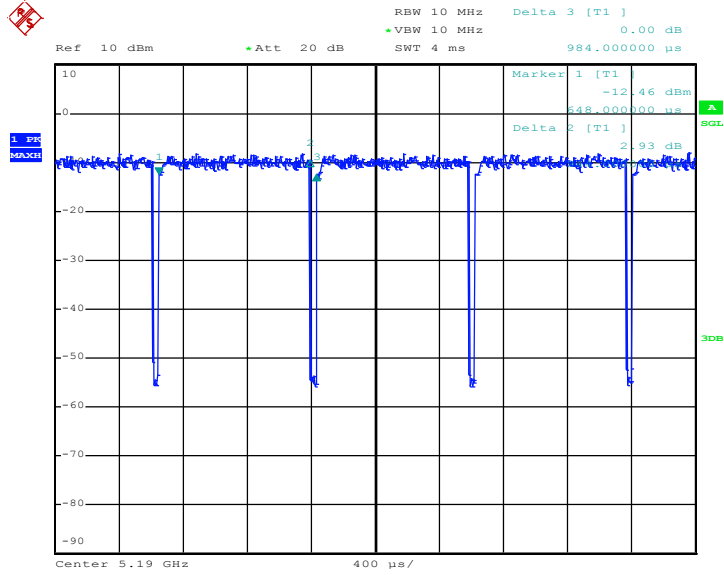

Date: 7.JUN.2018 03:27:49

802.11ac VHT20

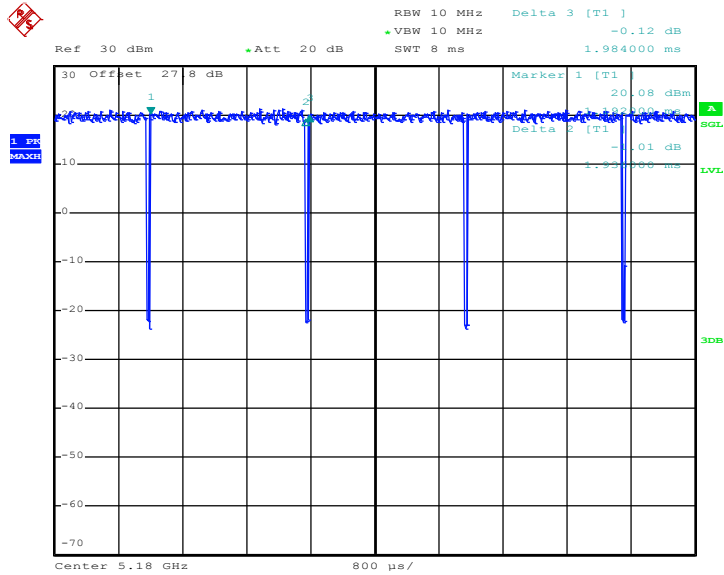

Date: 8.JUN.2018 23:59:03



802.11ac VHT40

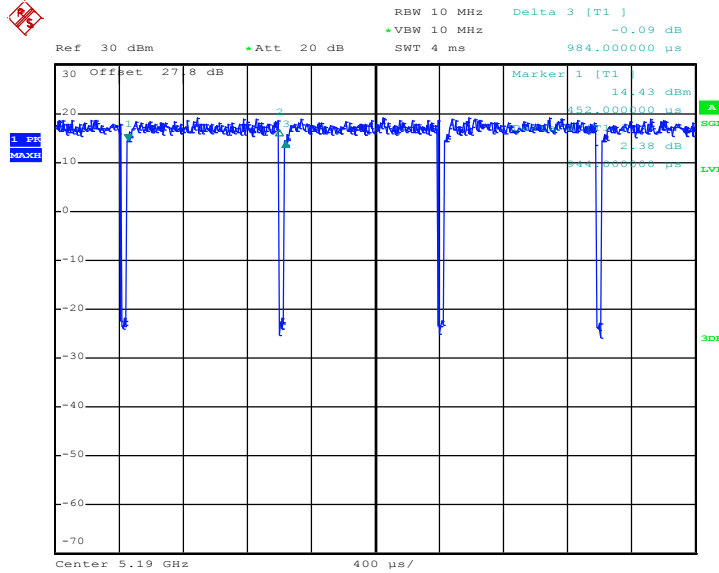

Date: 9.JUN.2018 00:06:19

802.11ac VHT80

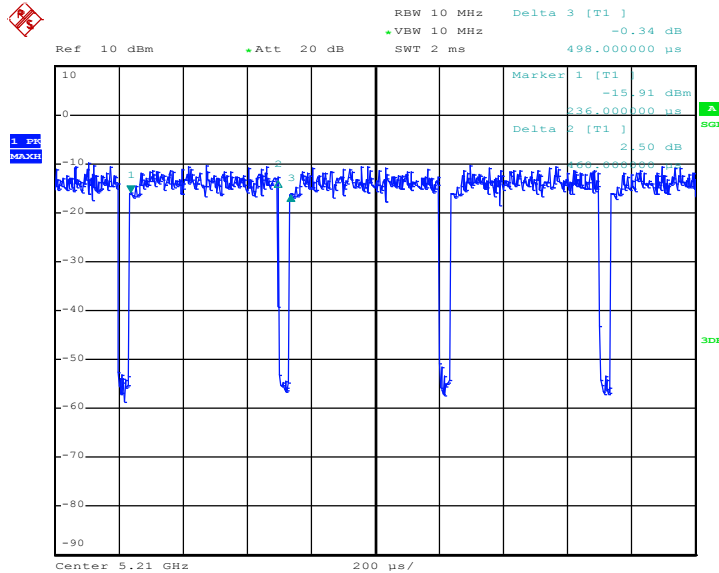

Date: 7.JUN.2018 03:40:50

————THE END————