



TerraPoiNT Portable Tracker (TPT) User Guide

Version 0.7

NextNav Confidential and Proprietary

All data and information contained in or disclosed by this document is confidential and proprietary information of NextNav, LLC and all rights therein are expressly reserved. By accepting this material, the recipient agrees that this material and the information contained therein is to be held in confidence and in trust and will not be disseminated, distributed, copied, reproduced in whole or in part, nor its contents revealed in any manner to others without the express written permission of NextNav LLC.

COPYRIGHT

No part of this publication may be reproduced in any form, in an electronic retrieval system or otherwise, without the prior written permission of the publisher. Material contained herein is reserved for members of NextNav and designated contractors, and therefore is not to be quoted, cited, or shown outside the company without written permission.

History

Version	Date	Author	Notes
0.1	18 st March, 2021	Purna Nannapaneni	1
0.3	24 st March, 2021	Purna Nannapaneni	2
0.4	26 st March, 2021	Purna Nannapaneni	3
0.5	26 st April, 2021	Purna Nannapaneni	5
0.6	27 st April, 2021	Purna Nannapaneni	6
0.7	24 st May, 2021	Purna Nannapaneni	7

Notes:

1. Created first draft version of document for internal review.
2. Updates :
 - a. Changed naming to TerraPoiNT Portable Tracker (TPT).
 - b. Added sections on unit powering ON/OFF, firmware versions.
 - c. Updated phone images.
 - d. Added test procedure flow chart.
3. Updates :
 - a. Added information on TerraPoiNT Tracker(TPT) App installation from App center.
4. Updates:
 - a. Minor updates.
5. Updates:
 - a. Updated RF Exposure description and FCC Label Information.
6. Updates:
 - a. Modified Phone app snapshots.
7. Updates:
 - a. Removed information related to external battery pack.

Table of Contents

History	2
1 FCC statements:	4
2 Scope	5
3 Introduction	6
4 Receiver – TPT	8
4.1 Model Name.....	8
4.2 Power	8
4.3 Powering ON the Receiver TPT	9
4.4 Powering OFF the Receiver TPT	9
4.5 Charging Receiver TPT:.....	10
5 Phone App - TPT	11
5.1 Receiver TPT and Phone App (TPT App):.....	11
5.2 Android Platform Requirements.....	11
5.3 TerraPoiNT Tracker(TPT) App Release via App Center.....	12
6 Altitude and Location Test Procedure	13
6.1 Test Flow:.....	13
6.3 Phone Interface: Bluetooth Pairing & Running of TPT App.....	14
6.4 Debug/Maintenance Interfaces.....	24
6.5 User Interface	24
6.6 Firmware & Software Versions	24
7 Mechanical Specifications – TPT	25
8 Environmental Characteristics	26
9 Interference Considerations	26
10 FCC Label	26

1 FCC statements:

This device complies with part 15 of the FCC rules. Operation is subject to the following two conditions: (1) this device may not cause harmful interference, and (2) this device must accept any interference received, including interference that may cause undesired operation.

NOTE: The manufacturer is not responsible for any radio or TV interference caused by unauthorized modifications or changes to this equipment. Such modifications or changes could void the user's authority to operate the equipment.

NOTE: This equipment has been tested and found to comply with the limits for a Class B digital device, pursuant to part 15 of the FCC Rules. These limits are designed to provide reasonable protection against harmful interference in a residential installation. This equipment generates uses and can radiate radio frequency energy and, if not installed and used in accordance with the instructions, may cause harmful interference to radio communications. However, there is no guarantee that interference will not occur in a particular installation. If this equipment does cause harmful interference to radio or television reception, which can be determined by turning the equipment off and on, the user is encouraged to try to correct the interference by one or more of the following measures:

- Reorient or relocate the receiving antenna.
- Increase the separation between the equipment and receiver.
- Connect the equipment into an outlet on a circuit different from that to which the receiver is connected.
- Consult the dealer or an experienced radio/TV technician for help.

RF exposure:

The device has been evaluated to meet general RF exposure requirement, The device can be used in portable exposure condition without restriction. Federal Communication Commission (FCC) Radiation Exposure Statement Power is so low that no RF exposure calculation is needed.

2 Scope

This Receiver User Guide describes all electrical, mechanical, operational and support aspects of TerraPoiNT Portable Tracker (**TPT**) MBS receiver. The TPT is very small and low power that supports single chip version of NextNav's MBS Receiver Technology along with GPS Receiver and multitude of sensors.

This manual reflects the latest iteration of the TPT with the 2021 hardware and software updates.

3 Introduction

Metropolitan Beacon System (MBS) is terrestrial location system designed to supplement GPS in areas where GPS signals are degraded or denied, such as indoors or in urban canyons. The terrestrially-located beacon transmitters radiate a highly synchronized, spread-spectrum signal that is similar in many respects to the L1 C/A signal, and enables appropriately-equipped receivers to trilaterate their position. In addition to traditional almanac information, MBS encodes barometric correction information to enable receivers that have a barometric pressure sensor to determine their altitude with very high accuracy. Additional information about the MBS signals can be found in the MBS Interface Control Document (ICD) [1]. NextNav MBS beacons operate on Part 90 M-LMS spectrum licenses that cover 919.75MHz - 927.75MHz, with permitted ERP up to 30W. The system currently supports a 10Hz location update rate, with position computed on the receiver with no need for external information. Like GPS, assisted modes of operation are supported. A high-level system architecture of MBS is shown in figure below.

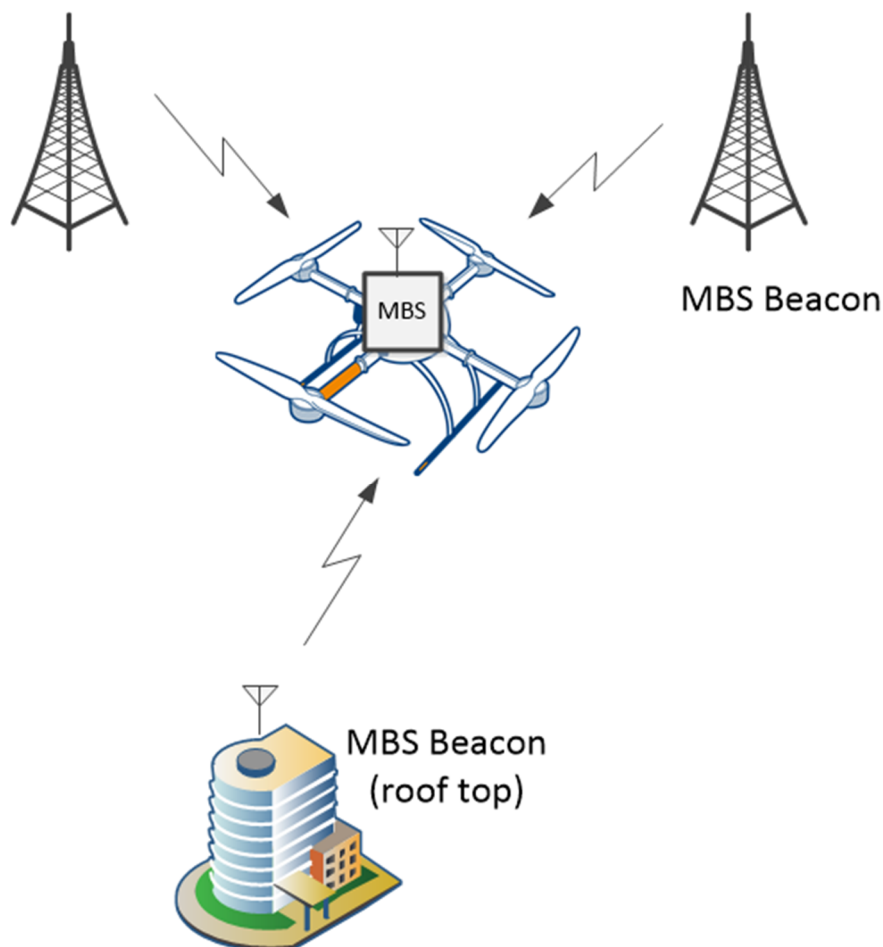

The block diagram of the TPT class receivers shown below.

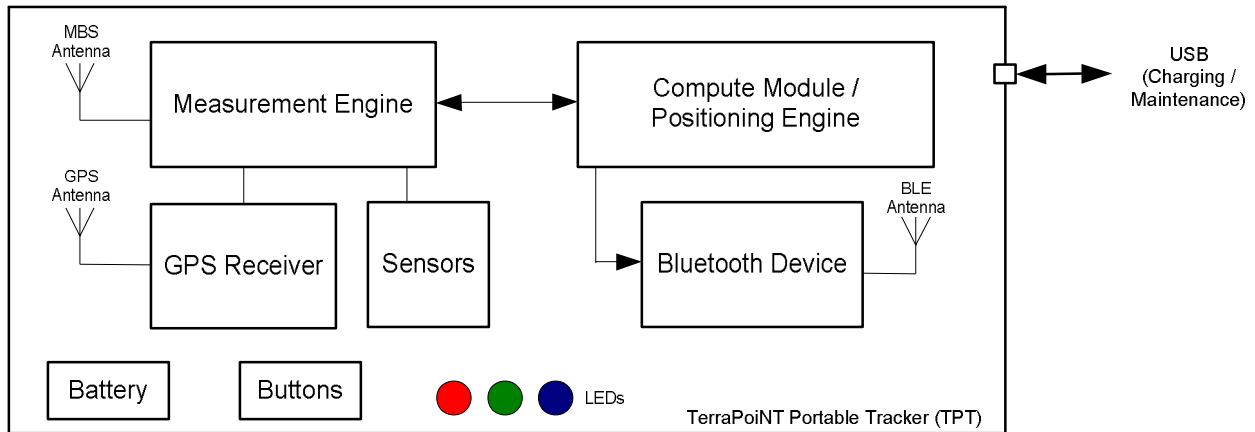

The TPT receiver system comprises of a measurement engine (ME) block, a compute module block, gps receiver and different sensors. The measurement engine block performs the acquisition and tracking of MBS beacon signals. The compute module receives the ME data and computes the ranges and trilateration to produce location fixes at 10Hz rate. The receiver is designed to interact and deliver location fixes to a host platform (Smart Phone) via Bluetooth.

4 Receiver – TPT

4.1 Model Name

The TPT's unit Model Name is NN-TR02-xx

4.2 Power

The TPT Unit runs on internal battery. The TPT can be plugged to a Host Computer thru a Type-C USB Connector for charging the internal battery.

Ratings:

- 5V, 400mA
- 2W (Max)



The TPT unit board powers with internal battery.

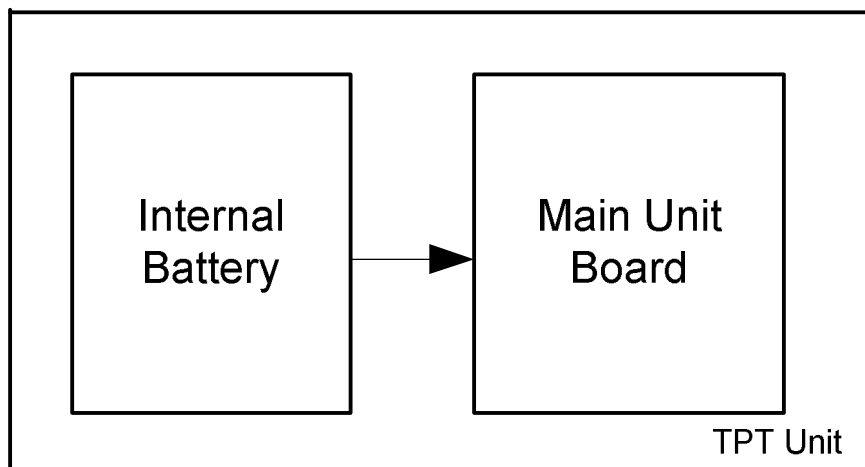

4.3 Powering ON the Receiver TPT

Make sure that the unit TPT is fully charged.

Press the rectangle big button momentarily for 1-second to turn the unit.



Press the rectangle big button momentarily for 1-second to turn ON the unit.

Blinking LEDs (on the sides of rectangular Button) indicates that Unit is Powered-ON and active.

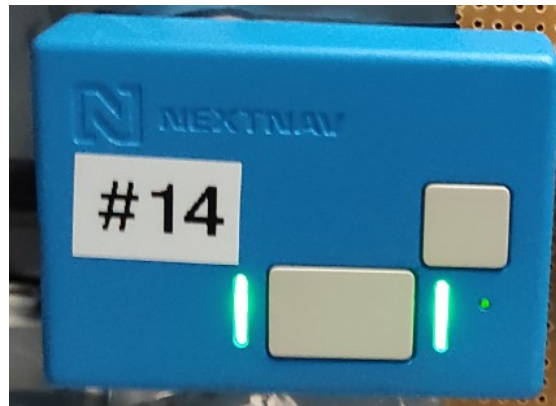

4.4 Powering OFF the Receiver TPT

The being in Power-ON state (blinking LEDs), press the big rectangular button for roughly 3-seconds until the LEDs are OFF (Unit Powered OFF).

It is to be noted that if the big rectangular button is pressed for greater than 7-seconds, the unit resets and Powers-ON automatically. This mode (pressing big rectangular button for more than 7-seconds) can be used to hard reset the TPT if the unit is unresponsive (or) struck.

4.5 Charging Receiver TPT:

The TPT

- Charging TPT Unit :
 - Step-1: Connect USB Port of TPT Unit's USB to a Host Computer thru a Type-C USB cable with a magnetic ring.
 - Step-2: Press Rectangular Button on front for a 1-sec to Power-ON the unit (LEDs Blink continuously).
 - Step-3: Leave it for 30-minutes to charge fully.

5 Phone App - TPT

5.1 Receiver TPT and Phone App (TPT App):

The TPT App on the Smart Phone interacts with the Receiver TPT over bluetooth Interface to send and receive data. The TPT on the Phone processes the Received data to calculate Altitude and Position and display in the App to the user.

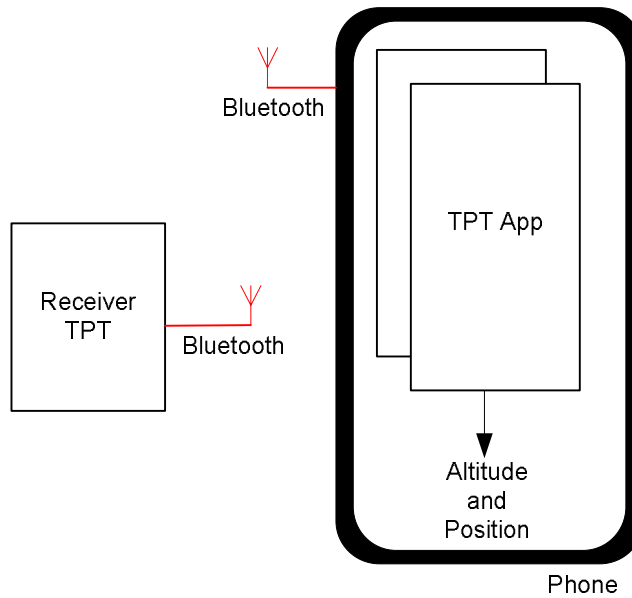

5.2 Android Platform Requirements

The TerraPoiNT Tracker App (TPT App) works on the following Android versions:

- I. Android 8.0
- II. Android 9.0
- III. Android 10.0

5.3 TerraPoiNT Tracker(TPT) App Release via App Center

The TerraPoiNT Tracker App is made available via the App Center.

Install 'TerraPoiNT Tracker'

for Android



Scan the code with your device camera, or visit the
install page on your device browser:

—

6 Altitude and Location Test Procedure.

This section provides information on the Test procedure of running of Altitude and Location test using Receiver TPT and Phone TPT App.

6.1 Test Flow:

The test flow is shown below.

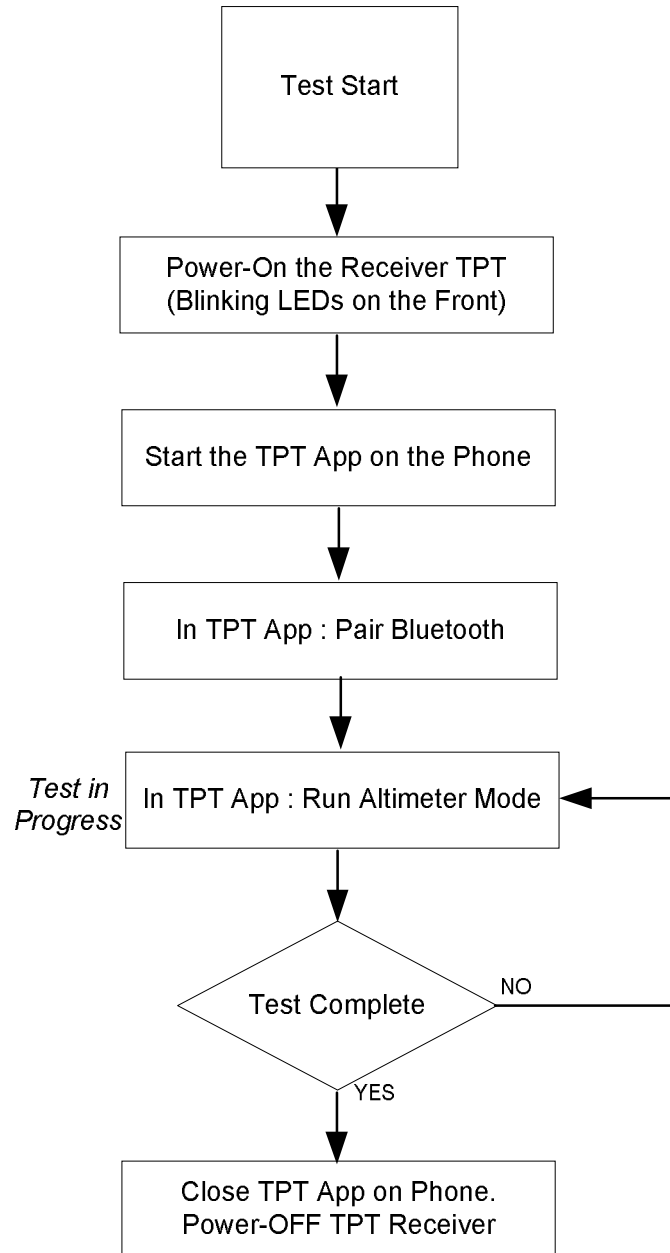

6.3 Phone Interface: Bluetooth Pairing & Running of TPT App

The Receiver TPT can connect to a Smart Phone thru Bluetooth Interface.

Once the TPT Receiver is paired to a smart phone, one can run Nextnav's TerraPoiNT Tracker(TPT) App on the phone to determine position and altitude metrics based on Bluetooth Interface data from Receiver TPT.

It is assumed that the TPT App is already installed on the Phone.

Select the TerraPoiNT Tracker(TPT) App icon (green) to invoke the TerraPoiNT Tracker App on the Phone as shown in below snapshot.

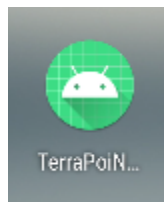

Press blue button "ACCEPT & CONTINUE".

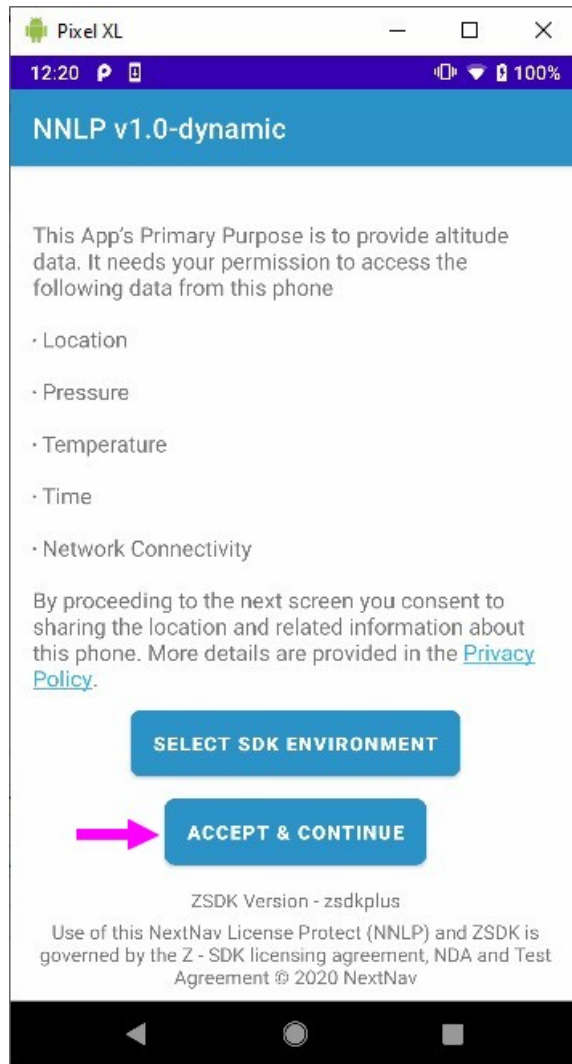

User will see momentarily the below screen. No action required from the user. After 10-seconds, all the buttons (ALTITUDE MODE, PAIR BLUETOOTH and CALIBRATE PHONE PRESSURE SENSOR) will become active.

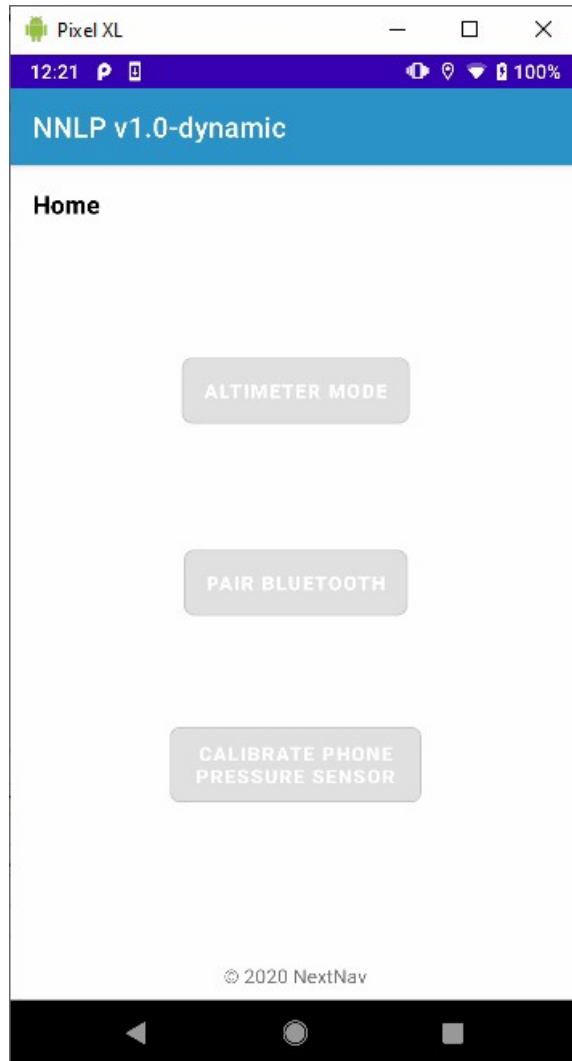

Press the middle button – “PAIR BLUETOOTH”.

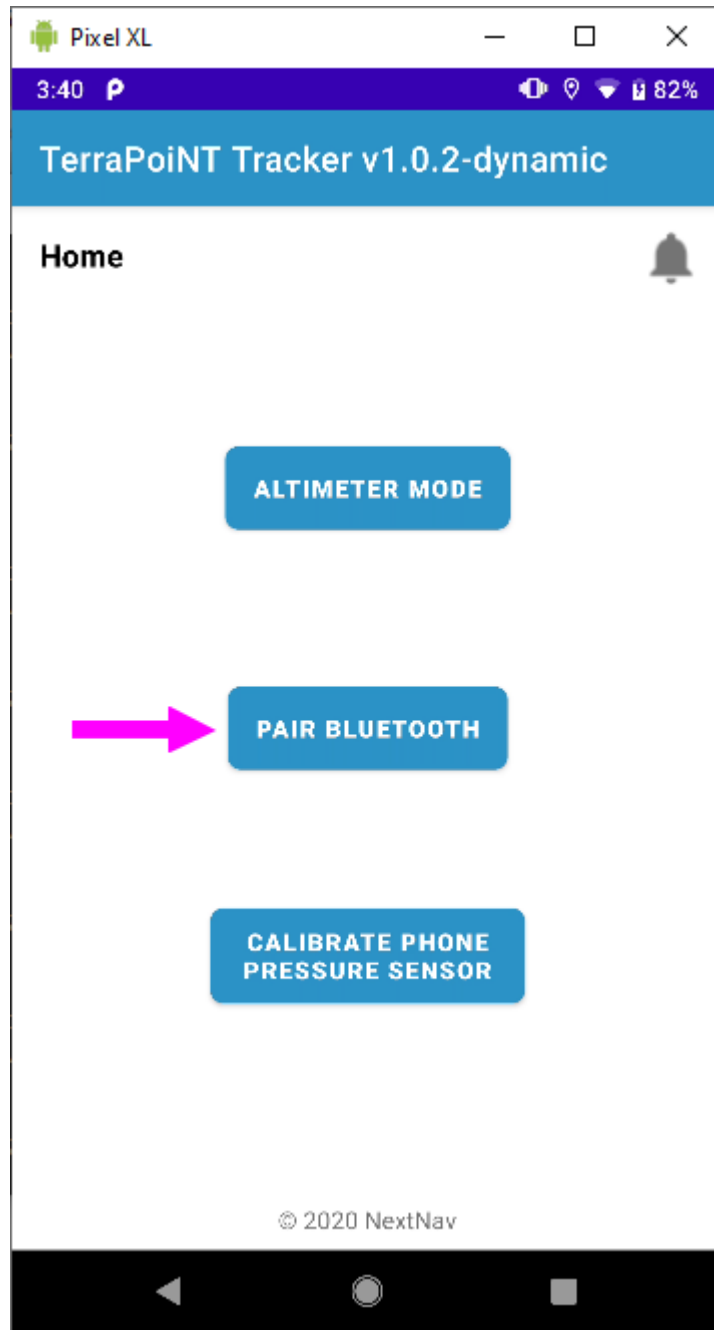

Identify the Receiver TPT unit's Bluetooth ID and press blue button "CONNECT"

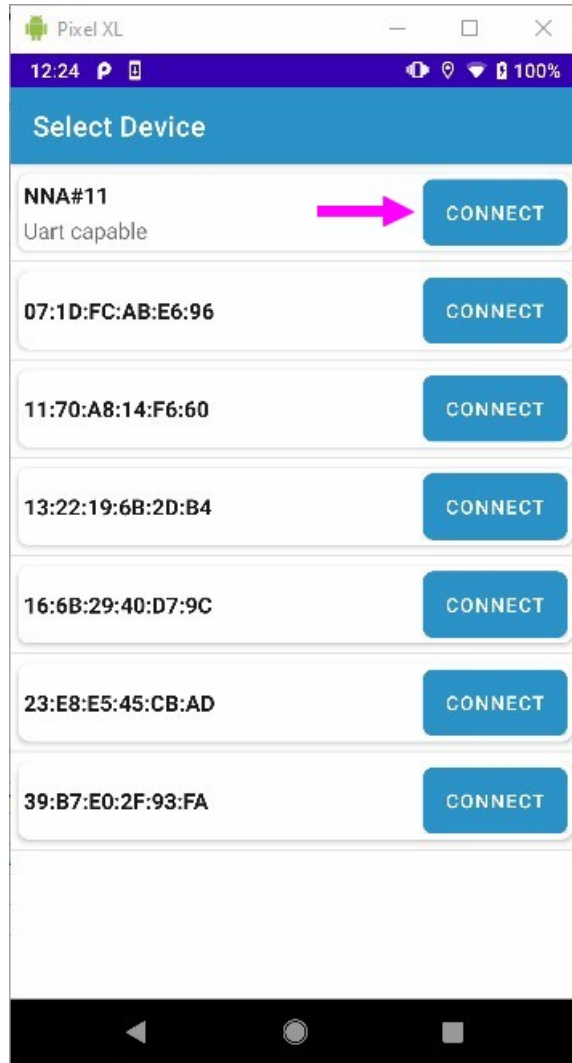

If the Phone is not Bluetooth paired to TPT (prior) then a pairing request pop-up is shown. User to select "Pair & connect" as shown below.

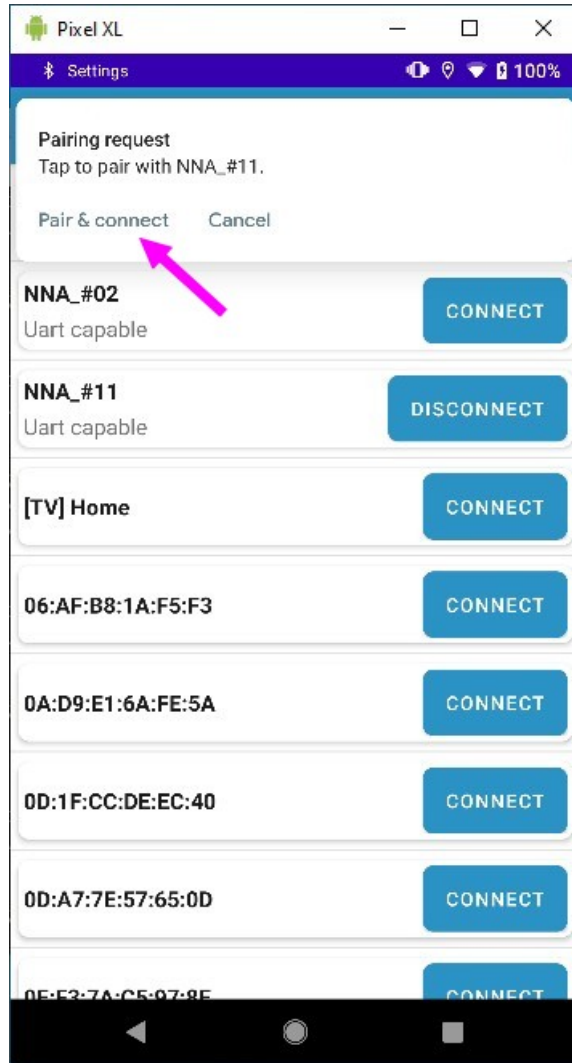

User to select "Pair" as shown below.

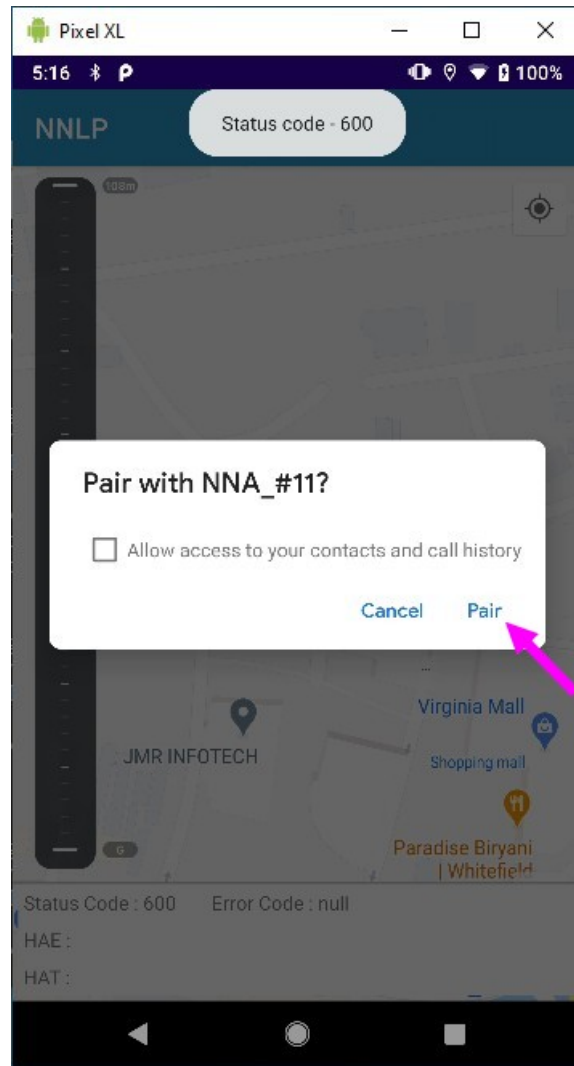

Press back button as highlighted below.

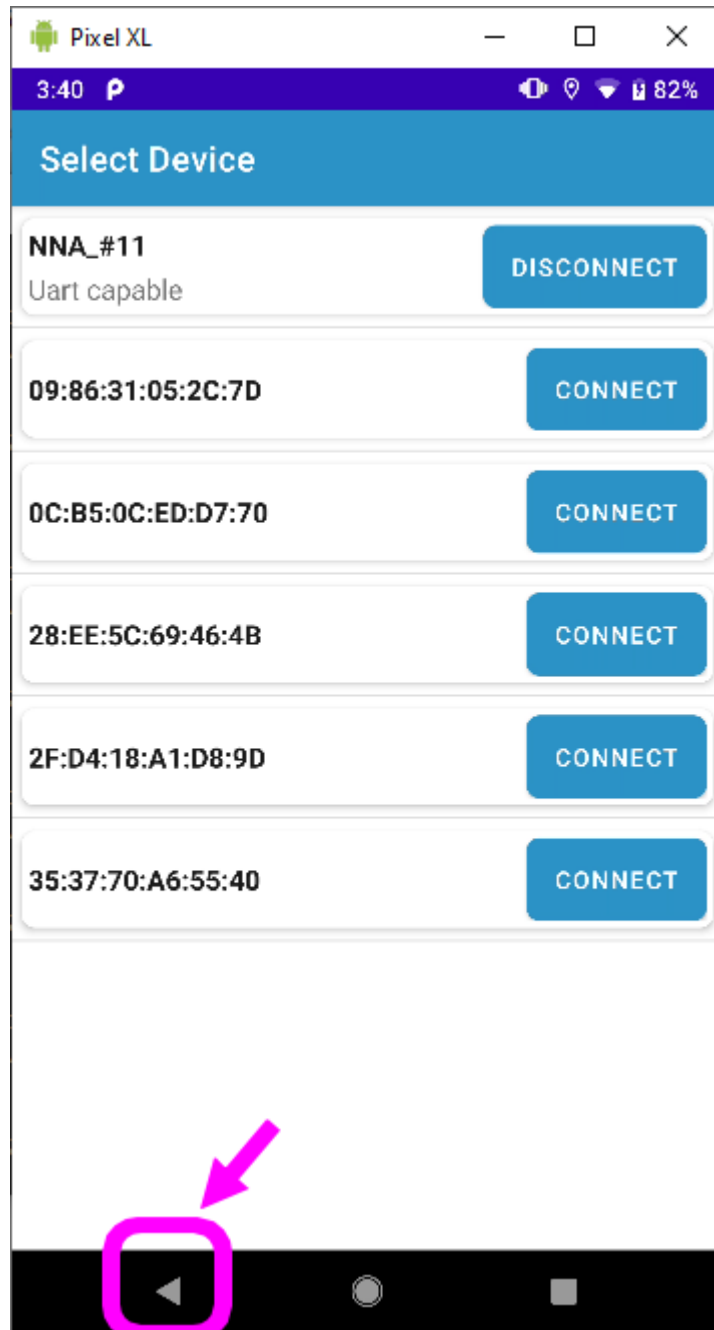

Press the "ALTIMETER MODE" button as shown below.

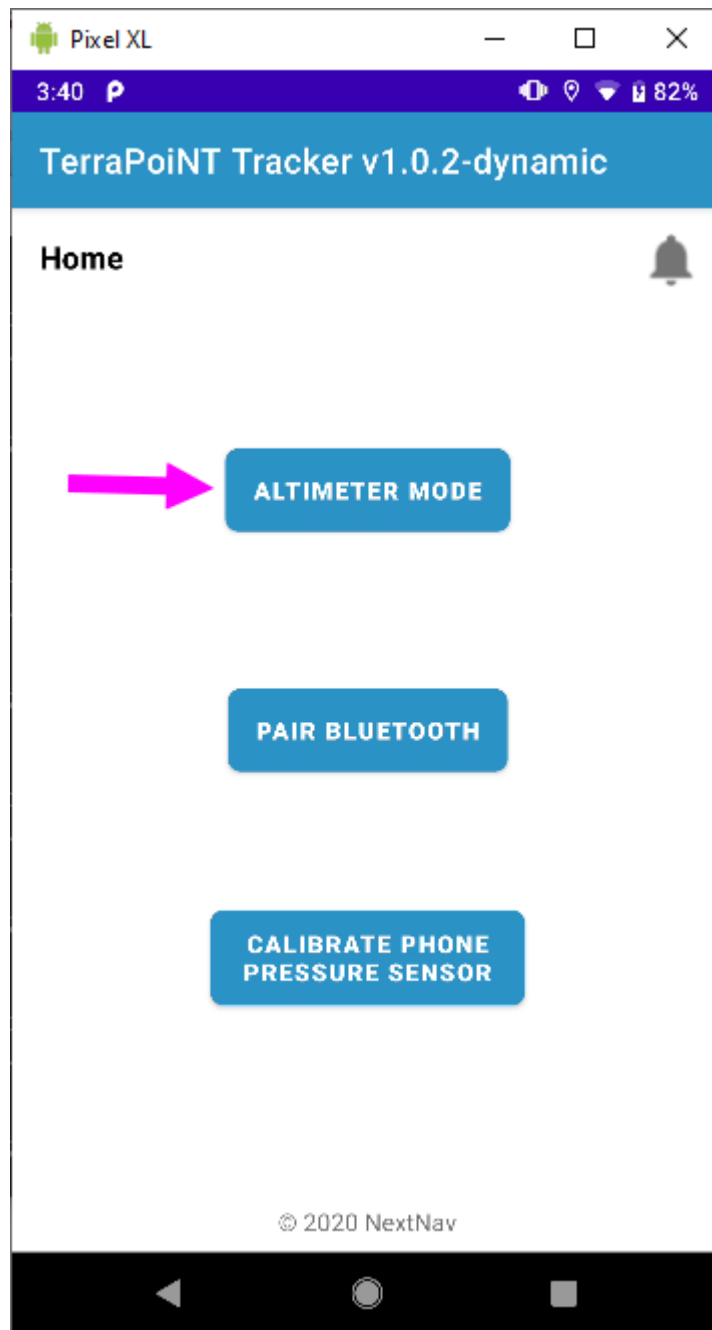

The App displays user location and altitude measurements as shown in below.

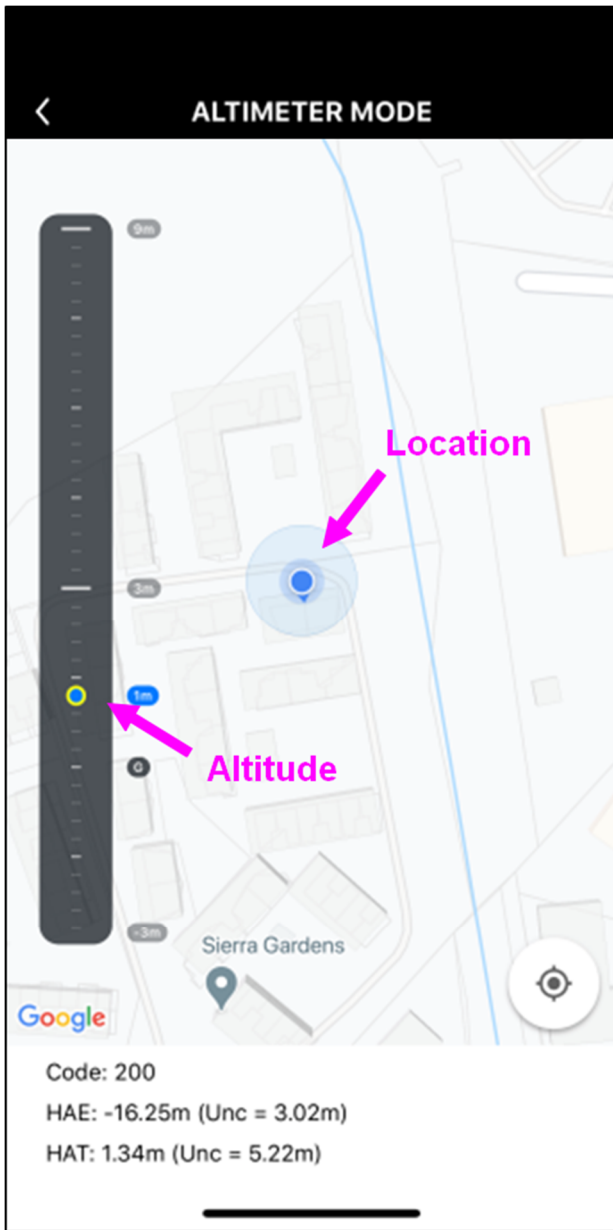

6.4 Debug/Maintenance Interfaces

The TPT Unit has a Type-C USB connector, which can be used to for following purposes.

- Charging the unit (Internal battery)
- Upgrade Firmware of different Devices on Board (Reserved for NextNav's use).
- Debug different Interfaces (Reserved for NextNav's use).

6.5 User Interface

An integrated set of 2 LEDs is available on the TPT unit platform to indicate Power-ON/OFF status of the TPT Device.

6.6 Firmware & Software Versions

The TPT Unit latest firmware versions of different are listed in below table.

S.No	Item	Version	Comments
1	STM32 Firmware Version	V0.1f	
2	nRF52832 Firmware Version	v0.1e	
3	GDM7243I	V1.0.0	
4	TPT Phone App	Vx.x.x	Use latest at App center.

7 Mechanical Specifications – TPT

Several images of the actual TPT unit from various angles are shown below.

- TPT unit's dimensions are 3.36" x 1.65" x 2"
- The TPT receiver weighs 6oz.



8 Environmental Characteristics

The TPT receiver platform is designed to operate under fair weather conditions. The platform can operate between 0 to 50°C. The unit can continue to operate under humid conditions.

9 Interference Considerations

The MBS signal operates in the 920-928MHz band.

10 FCC Label

Product name: TerraPoiNT Portable Tracker

Model name : NN-TR02_01

Trade name: NextNav

Brand name:TPT (TerraPoiNT Portable Tracker)

FCC ID: A4PTR0201

This device complies with part 15 of the FCC Rules. Operation is subject to the following two conditions: (1) This device may not cause harmful interference, and (2) this device must accept any interference received, including interference that may cause undesired operation.

