

承认书

SPECIFICATION FOR APPROVAL

客户名称 (CUSTOMER) eMoMo Technology Co.,Ltd

客户料号 (CUSTOMER P/N) :07-000128

品名 (DESCRIPTION):

DATE:2021/4/18

规格 (SPECIFICATION): G50 slotted + adhesive lead length 18mm REV.NO.:A0

深圳市鸿日昇威科技有限公司

HRSW ELECTRONICS CO.,LTD

ADD: 深圳市龙华新区观澜环观中路48号1栋2楼

TEL: +86-755-23461055 FAX: +86-0755-28015170

page:1/3

SPECIFICATION FOR APPROVAL

1. MECHANICAL DIMENSION (UNIT:mm)

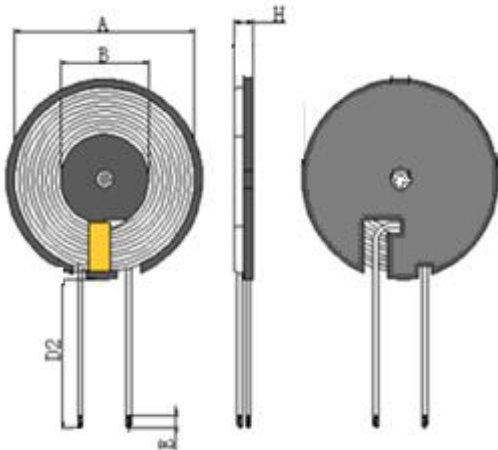

2. SCHEMATICS:

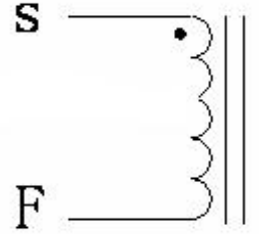

A	B	D2	E	H
50±1.0	20.5±0.5	18±3	4±1	2.8MAX

3. WINDING:

STEP	START-FINISH	WIRE TYPE	TURNS	TAPE	REMARK
N1	S-F	0.08*105mm*2P 2UEW-F	10TS (Ref)		

4. ELECTRICAL SPECIFICATION:

ITEM	L	DCR	IDC	Q值	HI-POT
TEST	coil plus magnet	S-F	S-F		
CON	100KHz, 0.25V	AT 25°C	AT 25°C		
SPEC	6.5uH±10%	60mΩ Max	5A		

SPECIFICATION FOR APPROVAL

6. SAMPLE TEST DATA									
6.1 DIMENSION TEST (UNIT: mm)									
TEST ITEM	A	B	D2	E	H				
SPEC	50±1.0	20.5±0.5	18±3	4±1	2.8Max				
1	49.5	20.51	18	3.5	2.56				
2	49.6	20.51	19	3.6	2.53				
3	49.8	20.52	18.5	4	2.54				
4	50	20.52	17.9	3.8	2.53				
5	49.98	20.51	20	4.9	2.40				
6									
7									
8									
9									
10									
MAX	50.00	20.52	20.00	4.90	2.56				
MIN	49.50	20.51	17.90	3.50	2.40				
AVERAGE	49.78	20.51	18.68	3.96	2.51				
6.2 ELECTRICAL TEST									
TEST ITEM	L		DCR	IDC		Q	HI-POT		
	S-F		S-F						
TEST COND	100KHz/0.25v		AT 25°C						
SPEC	6.5uH ±10%		60mΩ (Max)						
1	6.51		40.00						
2	6.53		39.90						
3	6.54		40.02						
4	6.53		40.10						
5	6.62		39.98						
6									
7									
8									
9									
10									
MAX	6.62		40.10						
MIN	6.51		39.90						
AVERAGE	6.55		40.00						
HRSW ELECTRONICS CO., LTD					PART NO		G50开槽+背胶引线长18mm		
					TITLE				