

SPECIFICATION FOR APPROVAL

1. MECHANICAL DIMENSION (UNIT:mm)

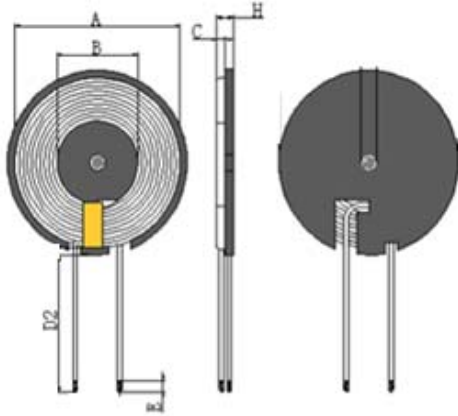

2. SCHEMATICS:

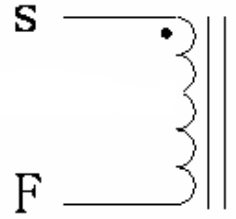

gain: 0dB

A	B	C	D2	E	H			I
49.5±0.5	20.5±0.5	0.9±0.05	18±3	3±2	2.6MAX	G50 slotted+	18mm	

3. WINDING:

1.1)

STEP	START-FINISH	WIRE TYPE	TURNS	TAPE	REMARK
N1	S-F	Wrapped wire 0.08 × 105 shares	10TS (Ref)		

4. ELECTRICAL SPECIFICATION:

ITEM	L	DCR			HI-POT
TEST	Coil plus magnetic sheet	S-F			
COND	100KHz, 0.25V	AT 25°C			
SPEC	6.4uH±10%	50mΩ Max			

5. BILF OF MATERIAL:

NO.	ITEM	MATERIAL SPECIFICATION	MANUFACTURER	SGS NO.
1	Wrapped wire 0.08 × 105 shares	Wrapped wire 0.08 × 105 shares	NANJINGJINNINGCO,LTD	
2	Solder Bar	Solder Bar	QIAODO	
3	Magnetic sheet	50mm diameter, 0.8 thick 1-slot magnetic sheet	TAIYI CO.,LTD	
4	glue	Yellow glue 999	LIANCHENG CO.,LTD	
5	High temperature adhesive tape	8mm wide high-temperature adhesive tape	CUDAK CO.,LTD	
6	Adhesive backing	ø49.5*0.1	CUDAK CO.,LTD	
7	Black membrane	ø49.5*0.1	CUDAK CO.,LTD	

HRSW ELECTRONICS CO.,LTD		PART NO	
		TITLE	
		G50 slotted+ 50mm	
DRAWN BY		CHECKED BY	
HEWEIHUA		WEILIHONG	
		APPROVED BY	
		WEILIHONG	