



深圳市深广电子科技有限公司

Shenzhen Shenguang Electronic Technology Co.,LTD

4 / F, Chongmei Industrial Park, No. 1165 Sightseeing Road, Longhua District, Shenzhen City, Guangdong Province,China

客户/Ciient eMoMo Technology Co., Ltd

名称/TYPE 跑道线圈/Runway coil

产品型号

Model NO ni=6.3uH ±10%

产品编号 20180305001

Part numbering systey _____

客户料号

Cient p/NO _____

工程编号

Enginrer NO TQE 1800510003

日期/Date 2020-1-10

本公司工程部/For Enginrer Departner Only	
修改内容/Rvised Cintent	认可日期/APProved Date

编制/Prepared

段家旺

审核/Checked

谢良



客户认可回签/Authorixed Signaturure Company Chop		
工程/ Enginrer	认可/QC APProved	认可日期/APProved



深圳市深广电子科技有限公司

Shenzhen Shengguang Electronic Technology Co.,LTD

4 / F, Chongmei Industrial Park, No. 1165 Sightseeing Road, Longhua District, Shenzhen City, Guangdong Province, China

一、线圈工艺/Winding Procese:

NO	绕组	线规	匝数	包胶圈数	备注
1	N1	2UEW-B-0.08*105P	9TS		
2					

二 . 电气性能/FEATURES:

1.测试条件 (Test conditions) : 25°C,65%RH@100KHz/1V

1.1 电感量 (Inductance) : L0A=6.3uH±10%

1.2 直流电阻 (DCR) : 75mΩ ±10%

1.3 Q 值测试 : N1: 55 Q±10% MIN

1.4 工作温度(Operating Temperature) : -25°C~85°C

2.测试仪器(Test instrument) : L:创达 1068+1310;DCR:502BC;SIZE:Callipers

3.材料清单

NO	项目	材料 materials
1	WIRE	φ 0.08*105p 2UEW-1.15mm
2	FERRITE	55*46*0.8 铁氧体硬磁
3	GLUE	白胶 white glues
4	SOLDER	XCD-907B
5	Adhesive	白色双面背胶 White double-sided tape



深圳市深广电子科技有限公司

Shenzhen Shengguang Electronic Technology Co.,LTD

4 / F, Chongmei Industrial Park, No. 1165 Sightseeing Road, Longhua District, Shenzhen City, Guangdong Province,China

三 . 电路图/CIRCUIT DIAGRAM

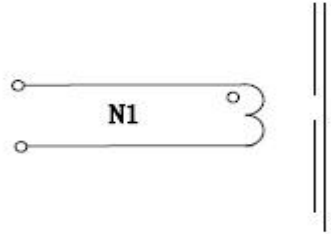

单位： MM

Gain:0dBi

四 . 外形图/OUTSIDE DIAGRAM

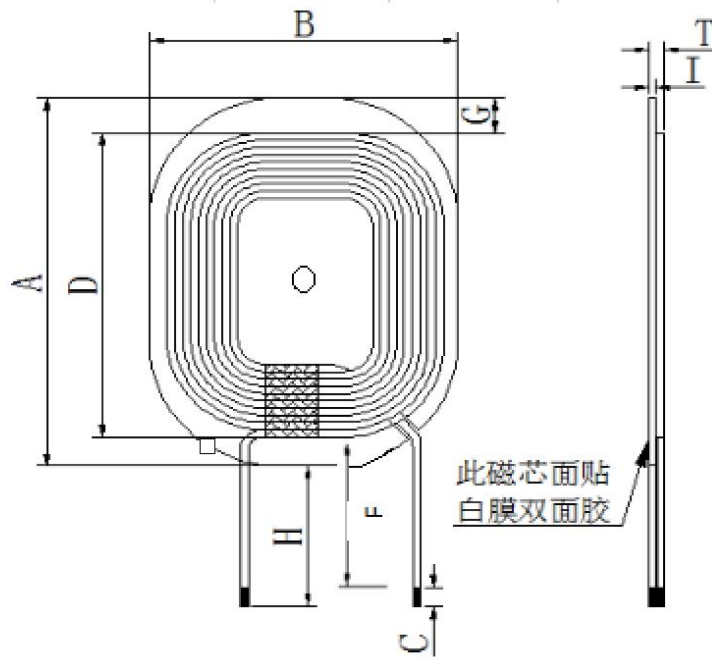

标准	A	B	C	D	G	H	I	T
STD	58.0±1.0	45±0.5	3±1	46±11.5.	4.5REF	20±2	0.8(Max)	2.3Max



深圳市深广电子科技有限公司

Shenzhen Shenguang Electronic Technology Co.,LTD

4 / F, Chongmei Industrial Park, No. 1165 Sightseeing Road, Longhua District, Shenzhen City, Guangdong Province, China

单位： MM

五、包装/PACKAGE

5.1 包装图片 Packing pictures:

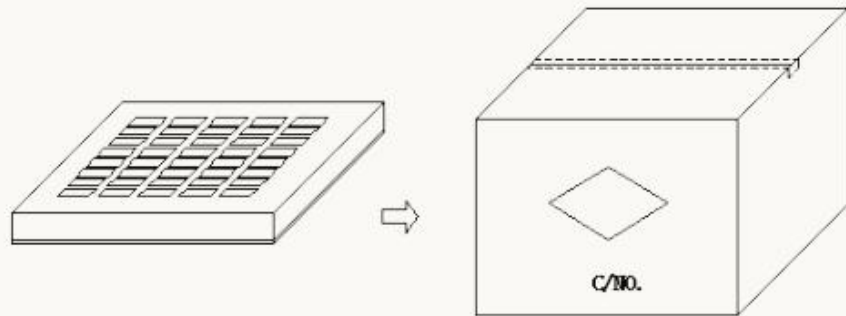

5.2 包装数量及规格 Packing Quantity:

项目 Item	数量 Quantity	材料规格 Material
盒 Box	350 Pcs	345*330*50 mm
箱 Big Carton	1400 Pcs	360*340*280 mm

5.3 包装以现有包装盘为参照标准，以实际出货包装为准，如有特需要求可以定制。

The packaging shall be based on the existing packing plate and the actual delivery package shall prevail. If there is any requirement, we can customize it.