

承认书

SPECIFICATION FOR APPROVAL

客户名称 (CUSTOMER): eMoMo Technology Co., Ltd

客户料号 (CUSTOMER P/N): 07-000128

品名 (DESCRIPTION): DATE: 2021/4/18

规格 (SPECIFICATION): G50开槽+背胶引线长18mm REV.NO.:A0

鸿日昇威科技承认签核、盖章

部门	确认/日期	审核/日期	批准/日期	(盖公司公章)
品质	董晚红 2021/4/18	吕惠 2021/4/18	韦函满 2021/4/18	
工程	何伟华 2021/4/18	韦立红 2021/4/18	韦立红 2021/4/18	

备注:

一么么科技承认签核、盖章

部门	确认/日期	审核/日期	批准/日期	(盖公司公章)
开发工程师				
采购				
品质				

备注:

深圳市鸿日昇威科技有限公司

HRSW ELECTRONICS CO.,LTD

ADD: 深圳市龙华新区观澜环观中路48号1栋2楼

ADD: 2nd Floor, Building 1, No. 48 Huanguan Middle Road, Guanlan, Longhua New District, Shenzhen

TEL: +86-755-23461055 FAX: +86-0755-28015170

page:1/3

SPECIFICATION FOR APPROVAL

1. MECHANICAL DIMENSION (UNIT:mm)

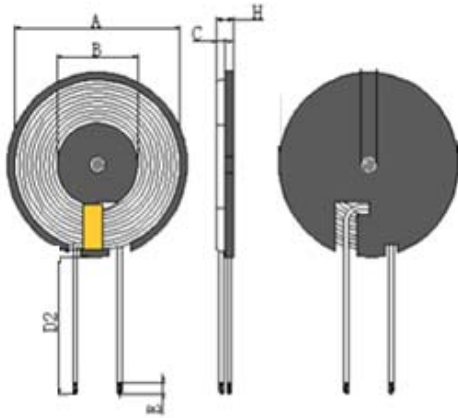

2. SCHEMATICS:

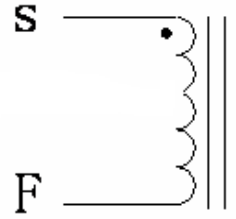

A	B	C	D2	E	H			I
49.5±0.5	20.5±0.5	0.9±0.05	18±3	3±2	2.6MAX	G50 slotted+	18mm	

3. WINDING: 1.1f

STEP	START-FINISH	WIRE TYPE	TURNS	TAPE	REMARK
N1	S-F	Wrapped wire 0.08 × 105 shares	10TS (Ref)		

4. ELECTRICAL SPECIFICATION:

ITEM	L	DCR			HI-POT
TEST	Coil plus magnetic sheet	S-F			
COND	100KHz, 0.25V	AT 25°C			
SPEC	6.4uH±10%	50mΩ Max			

5. BILF OF MATERIAL:

NO.	ITEM	MATERIAL SPECIFICATION	MANUFACTURER	SGS NO.
1	Wrapped wire 0.08 × 105 shares	Wrapped wire 0.08 × 105 shares	NANJINGJINNINGCO,LTD	
2	Solder Bar	Solder Bar	QIAODO	
3	Magnetic sheet	50mm diameter, 0.8 thick 1-slot magnetic sheet	TAIYI CO.,LTD	
4	glue	Yellow glue 999	LIANCHENG CO.,LTD	
5	High temperature adhesive tape	8mm wide high-temperature adhesive tape	CUDAK CO.,LTD	
6	Adhesive backing	ø49.5*0.1	CUDAK CO.,LTD	
7	Black membrane	ø49.5*0.1	CUDAK CO.,LTD	

HRSW ELECTRONICS CO.,LTD		PART NO	
		TITLE	
		G50 slotted+ 50mm	
DRAWN BY		CHECKED BY	
HEWEIHUA		WEILIHONG	
		APPROVED BY	
		WEILIHONG	

SPECIFICATION FOR APPROVAL

6. SAMPLE TEST DATA									
6.1 DIMENSION TEST (UNIT: mm)									
TEST ITEM	A	B	D2	E	H				
SPEC	50±1.0	20.5±0.5	18±3	4±1	2.8Max				
1	49.5	20.51	18	3.5	2.56				
2	49.6	20.51	19	3.6	2.53				
3	49.8	20.52	18.5	4	2.54				
4	50	20.52	17.9	3.8	2.53				
5	49.98	20.51	20	4.9	2.40				
6									
7									
8									
9									
10									
MAX	50.00	20.52	20.00	4.90	2.56				
MIN	49.50	20.51	17.90	3.50	2.40				
AVERAGE	49.78	20.51	18.68	3.96	2.51				
6.2 ELECTRICAL TEST									
TEST ITEM	L		DCR	IDC		Q	HI-POT		
	S-F		S-F						
TEST COND	100KHz/0.25v		AT 25°C						
SPEC	6.5uH ±10%		60mΩ (Max)						
1	6.51		40.00						
2	6.53		39.90						
3	6.54		40.02						
4	6.53		40.10						
5	6.62		39.98						
6									
7									
8									
9									
10									
MAX	6.62		40.10						
MIN	6.51		39.90						
AVERAGE	6.55		40.00						
HRSW ELECTRONICS CO., LTD					PART NO				
					TITLE		G50开槽+背胶引线长18mm		
DRAWN BY			CHECKED BY			APPROVED BY			
何伟华			韦立红			韦立红			