



# RADIO TEST REPORT

Test Report No. : 11347427H-B-R1

**Applicant** : RM Acquisition LLC  
**Type of Equipment** : Bluetooth Low Energy Tag  
**Model No.** : RMTRKBT1  
**FCC ID** : A4C91002A  
**Test regulation** : FCC Part 15 Subpart C: 2016  
**Test Result** : Complied

1. This test report shall not be reproduced in full or partial, without the written approval of UL Japan, Inc.
2. The results in this report apply only to the sample tested.
3. This sample tested is in compliance with the above regulation.
4. The test results in this report are traceable to the national or international standards.
5. This test report must not be used by the customer to claim product certification, approval, or endorsement by NVLAP, NIST, or any agency of the Federal Government.
6. This test report covers Radio technical requirements. It does not cover administrative issues such as Manual or non-Radio test related Requirements. (if applicable)
7. This report is a revised version of 11347427H-B. 11347427H-B is replaced with this report.

**Date of test:** August 19 and 23, 2016

**Representative test engineer:**

*T. Noguchi*

Takafumi Noguchi  
Engineer  
Consumer Technology Division

**Approved by:**

*Takayuki S.*

Takayuki Shimada  
Engineer  
Consumer Technology Division



NVLAP LAB CODE: 200572-0

This laboratory is accredited by the NVLAP LAB CODE 200572-0, U.S.A. The tests reported herein have been performed in accordance with its terms of accreditation.  
\*As for the range of Accreditation in NVLAP, you may refer to the WEB address,  
[http://japan.ul.com/resources/emc\\_accredited/](http://japan.ul.com/resources/emc_accredited/)

**UL Japan, Inc.**

**Ise EMC Lab.**

4383-326 Asama-cho, Ise-shi, Mie-ken 516-0021 JAPAN

Telephone : +81 596 24 8999

Facsimile : +81 596 24 8124

13-EM-F0429



---

<b>CONTENTS</b>	<b>PAGE</b>
<b>SECTION 1: Customer information.....</b>	<b>4</b>
<b>SECTION 2: Equipment under test (E.U.T.).....</b>	<b>4</b>
<b>SECTION 3: Test specification, procedures &amp; results.....</b>	<b>5</b>
<b>SECTION 4: Operation of E.U.T. during testing.....</b>	<b>8</b>
<b>SECTION 5: Radiated Spurious Emission .....</b>	<b>10</b>
<b>SECTION 6: Antenna Terminal Conducted Tests.....</b>	<b>12</b>
<b>APPENDIX 1: Test data .....</b>	<b>13</b>
6dB Bandwidth .....	13
Maximum Peak Output Power .....	15
Average Output Power .....	16
Radiated Spurious Emission .....	18
Conducted Spurious Emission .....	24
Power Density .....	27
99% Occupied Bandwidth .....	29
<b>APPENDIX 2: Test instruments .....</b>	<b>30</b>
<b>APPENDIX 3: Photographs of test setup .....</b>	<b>31</b>
Radiated Spurious Emission .....	31
Worst Case Position .....	32

## **SECTION 1: Customer information**

Company Name : RM Acquisition LLC  
Address : 9855 Woods Dr.Skokie , IL 60077  
Telephone Number : +1-800-333-0136  
Contact Person : Wei Wu

## **SECTION 2: Equipment under test (E.U.T.)**

### **2.1 Identification of E.U.T.**

Type of Equipment : Bluetooth Low Energy Tag  
Model No. : RMTRKBT1  
Serial No. : Refer to Section 4, Clause 4.2  
Rating : DC 3 V  
Receipt Date of Sample : August 18, 2016  
Country of Mass-production : China  
Condition of EUT : Engineering prototype  
(Not for Sale: This sample is equivalent to mass-produced items.)  
Modification of EUT : No Modification by the test lab

### **2.2 Product Description**

Model: RMTRKBT1 (referred to as the EUT in this report) is a Bluetooth Low Energy Tag.

### **Radio Specification**

Radio Type : Transceiver  
Frequency of Operation : 2402 MHz - 2480 MHz  
Modulation : GFSK  
Power Supply (radio part input) : DC 1.67 V  
Antenna type : Inverted-F pattern antenna  
Antenna Gain : -0.5 dBi  
Clock frequency (Maximum) : 16 MHz  
32.768 kHz

## **SECTION 3: Test specification, procedures & results**

### **3.1 Test Specification**

Test Specification : FCC Part 15 Subpart C  
FCC Part 15 final revised on November 14, 2016 and effective December 14, 2016

Title : FCC 47CFR Part15 Radio Frequency Device Subpart C Intentional Radiators  
Section 15.207 Conducted limits  
Section 15.247 Operation within the bands 902-928MHz,  
2400-2483.5MHz, and 5725-5850MHz

\* The revision on November 14, 2016, does not affect the test specification applied to the EUT.

\* Also the EUT complies with FCC Part 15 Subpart B.

### **3.2 Procedures and results**

Item	Test Procedure	Specification	Worst margin	Results	Remarks
Conducted Emission	FCC: ANSI C63.10-2013 6. Standard test methods ----- IC: RSS-Gen 8.8	FCC: Section 15.207 ----- IC: RSS-Gen 8.8	-	N/A *1)	-
6dB Bandwidth	FCC: KDB 558074 D01 DTS Meas Guidance v03r05 ----- IC: -	FCC: Section 15.247(a)(2) ----- IC: RSS-247 5.2(1)	See data.	Complied	Conducted
Maximum Peak Output Power	FCC: KDB 558074 D01 DTS Meas Guidance v03r05 ----- IC: RSS-Gen 6.12	FCC: Section 15.247(b)(3) ----- IC: RSS-247 5.4(4)		Complied	Conducted
Power Density	FCC: KDB 558074 D01 DTS Meas Guidance v03r05 ----- IC: -	FCC: Section 15.247(e) ----- IC: RSS-247 5.2(2)		Complied	Conducted
Spurious Emission Restricted Band Edges	FCC: KDB 558074 D01 DTS Meas Guidance v03r05 ----- IC: RSS-Gen 6.13	FCC: Section15.247(d) ----- IC: RSS-247 5.5 RSS-Gen 8.9 RSS-Gen 8.10	7.2 dB 7206.000 MHz, AV, Vertical	Complied	Conducted (below 30 MHz)/ Radiated (above 30 MHz) *2)

Note: UL Japan, Inc.'s EMI Work Procedures No. 13-EM-W0420 and 13-EM-W0422.

\*1) The test is not applicable since the EUT does not have AC Mains.

\*2) Radiated test was selected over 30 MHz based on section 15.247(d) and KDB 558074 D01 DTS Meas Guidance v03r05 12.2.7.

\* In case any questions arise about test procedure, ANSI C63.10: 2013 is also referred.

#### **FCC Part 15.31 (e)**

The test was performed with the New Battery (DC 3 V) and the stable voltage was supplied to the EUT during the tests. Therefore, the EUT complies with the requirement.

#### **FCC Part 15.203 Antenna requirement**

It is impossible for end users to replace the antenna, because the antenna is mounted inside of the EUT. Therefore, the equipment complies with the antenna requirement of Section 15.203.

**UL Japan, Inc.**

**Ise EMC Lab.**

4383-326 Asama-cho, Ise-shi, Mie-ken 516-0021 JAPAN

Telephone : +81 596 24 8999

Facsimile : +81 596 24 8124

### 3.3 Addition to standard

Item	Test Procedure	Specification	Worst margin	Results	Remarks
99% Occupied Bandwidth	IC: RSS-Gen 6.6	IC: -	N/A	-	Conducted

Other than above, no addition, exclusion nor deviation has been made from the standard.

### 3.4 Uncertainty

#### EMI

The following uncertainties have been calculated to provide a confidence level of 95 % using a coverage factor  $k = 2$ .  
Ise EMC Lab.

Antenna terminal test Uncertainty (+/-)							
Power meter		Conducted emission and Power density			Conducted emission		Channel power
Below 1 GHz	Above 1 GHz	Below 1 GHz	1 GHz -3 GHz	3 GHz -18 GHz	18 GHz -26.5 GHz	26.5 GHz -40 GHz	
0.9 dB	1.0 dB	1.4 dB	1.7 dB	2.8 dB	2.8 dB	2.9 dB	2.6 dB

Polarity	Radiated emission (Below 1GHz)			
	(3 m*) (+/-)		(10 m*) (+/-)	
	30 – 200 MHz	200 – 1000MHz	30 – 200 MHz	200 – 1000MHz
Horizontal	5.0 dB	5.3 dB	5.0 dB	5.0 dB
Vertical	4.7 dB	5.9 dB	5.0 dB	5.1 dB

Radiated emission (Above 1GHz)				
(3 m*) (+/-)		(1 m*) (+/-)		(10 m*) (+/-)
1 – 6GHz	6 – 18GHz	10 – 26.5 GHz	26.5 – 40GHz	1 -18 GHz
5.2 dB	5.4 dB	5.5 dB	5.5 dB	5.4 dB

\*Measurement distance

#### Radiated emission test

The data listed in this test report has enough margin, more than the site margin.

### 3.5 Test Location

UL Japan, Inc. Ise EMC Lab. \*NVLAP Lab. code: 200572-0  
 4383-326 Asama-cho, Ise-shi, Mie-ken 516-0021 JAPAN  
 Telephone: +81 596 24 8999, Facsimile: +81 596 24 8124

Test site	IC Registration Number	Width x Depth x Height (m)	Size of reference ground plane (m) / horizontal conducting plane	Other rooms	Maximum measurement distance
No.1 semi-anechoic chamber	2973C-1	19.2 x 11.2 x 7.7	7.0 x 6.0	No.1 Power source room	10 m
No.2 semi-anechoic chamber	2973C-2	7.5 x 5.8 x 5.2	4.0 x 4.0	-	3 m
No.3 semi-anechoic chamber	2973C-3	12.0 x 8.5 x 5.9	6.8 x 5.75	No.3 Preparation room	3 m
No.3 shielded room	-	4.0 x 6.0 x 2.7	N/A	-	-
No.4 semi-anechoic chamber	2973C-4	12.0 x 8.5 x 5.9	6.8 x 5.75	No.4 Preparation room	3 m
No.4 shielded room	-	4.0 x 6.0 x 2.7	N/A	-	-
No.5 semi-anechoic chamber	-	6.0 x 6.0 x 3.9	6.0 x 6.0	-	-
No.6 shielded room	-	4.0 x 4.5 x 2.7	4.0 x 4.5	-	-
No.6 measurement room	-	4.75 x 5.4 x 3.0	4.75 x 4.15	-	-
No.7 shielded room	-	4.7 x 7.5 x 2.7	4.7 x 7.5	-	-
No.8 measurement room	-	3.1 x 5.0 x 2.7	N/A	-	-
No.9 measurement room	-	8.8 x 4.6 x 2.8	2.4 x 2.4	-	-
No.11 measurement room	-	6.2 x 4.7 x 3.0	4.8 x 4.6	-	-

### 3.6 Test data, Test instruments, and Test set up

Refer to APPENDIX.

## **SECTION 4: Operation of E.U.T. during testing**

### **4.1 Operating Mode(s)**

Bluetooth (BT) Low Energy (LE): Transmitting (Tx)

Test Item	Operating Mode	Tested Frequency
Conducted / Radiated Spurious Emission 6dB Bandwidth Maximum Peak Output Power Power Density 99% Occupied Bandwidth	Tx BT LE	2402MHz 2440MHz 2480MHz
<p>*Power of the EUT was set by the software as follows;  Power settings: 4 dBm  Software: Z_HRM5094_RadioTest_NoSoftDevice_160630  *This setting of software is the worst case.  Any conditions under the normal use do not exceed the condition of setting.  In addition, end users cannot change the settings of the output power of the product.</p>		

### **4.2 Configuration and peripherals**

#### **< Radiated Spurious Emission >**

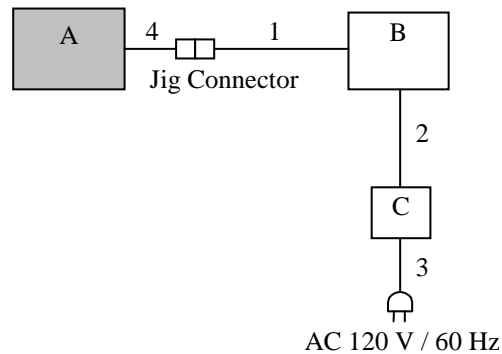

#### **< Antenna Terminal Conducted Tests >**

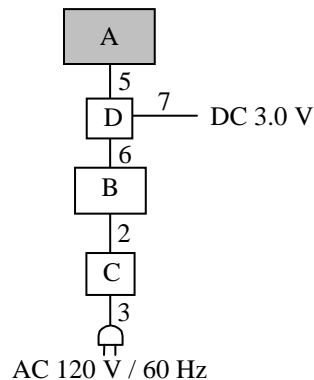

\* Cabling and setup(s) were taken into consideration and test data was taken under worse case conditions.

**UL Japan, Inc.**

**Ise EMC Lab.**

4383-326 Asama-cho, Ise-shi, Mie-ken 516-0021 JAPAN

Telephone : +81 596 24 8999

Facsimile : +81 596 24 8124



**Description of EUT and Support equipment**

No.	Item	Model number	Serial number	Manufacturer	Remarks
A	Bluetooth Low Energy Tag	RMTRKBT1	No.1 *1) No.2 *2)	Hosiden Corporation	EUT
B	Note PC	FMV-A8260	R8800679	FUJITSU LIMITED	-
C	AC Adapter	ADP-80NBA	10268063C	FUJITSU LIMITED	-
D	Jig	-	-	-	-

\*1) Used for Radiated Emission test only.

\*2) Used for Antenna Terminal Conducted Test only.

**List of cables used**

No.	Name	Length (m)	Shield		Remarks
			Cable	Connector	
1	USB Cable	1.8	Shielded	Shielded	-
2	DC Cable	1.8	Unshielded	Unshielded	-
3	AC Cable	0.9	Unshielded	Unshielded	-
4	Jig Cable	0.06	Unshielded	Unshielded	-
5	Signal Cable	0.2	Unshielded	Unshielded	-
6	Signal Cable	0.1	Shielded	Shielded	-
7	DC Cable	0.1	Unshielded	Unshielded	-

**UL Japan, Inc.**

**Ise EMC Lab.**

4383-326 Asama-cho, Ise-shi, Mie-ken 516-0021 JAPAN

Telephone : +81 596 24 8999

Facsimile : +81 596 24 8124

## **SECTION 5: Radiated Spurious Emission**

### **Test Procedure**

It was measured based on "11.0 Emissions in non-restricted frequency bands" of "558074 D01 DTS Meas Guidance v03r05".

[For below 1 GHz]

EUT was placed on a urethane platform of nominal size, 0.5 m by 1.0 m, raised 0.8 m above the conducting ground plane. The Radiated Electric Field Strength has been measured in a Semi Anechoic Chamber with a ground plane.

[For above 1 GHz]

EUT was placed on a urethane platform of nominal size, 0.5 m by 0.5 m, raised 1.5 m above the conducting ground plane.

The Radiated Electric Field Strength has been measured in a Semi Anechoic Chamber with absorbent materials lined on a ground plane.

The height of the measuring antenna varied between 1 and 4 m and EUT was rotated a full revolution in order to obtain the maximum value of the electric field strength.

The measurements were performed for both vertical and horizontal antenna polarization with the Test Receiver, or the Spectrum Analyzer.

The measurements were made with the following detector function of the test receiver and the Spectrum analyzer (in linear mode).

The test was made with the detector (RBW/VBW) in the following table.

When using Spectrum analyzer, the test was made with adjusting span to zero by using peak hold.

### **Test Antennas are used as below;**

Frequency	30 MHz to 200 MHz	200 MHz to 1 GHz	Above 1 GHz
Antenna Type	Biconical	Logperiodic	Horn

In any 100 kHz bandwidth outside the restricted band in which the spread spectrum intentional radiator is operating, the radio frequency power that is produced by the intentional radiator confirmed 20 dB below that in the 100 kHz bandwidth within the band that contains the highest level of the desired power, based on a radiated measurement.

**20 dBc was applied to the frequency over the limit of FCC 15.209 / Table 4 of RSS-Gen 8.9(IC) and outside the restricted band of FCC15.205 / Table 6 of RSS-Gen 8.10 (IC).**

Frequency	Below 1 GHz	Above 1 GHz		20 dBc
Instrument used	Test Receiver	Spectrum Analyzer		Spectrum Analyzer
Detector	QP	PK	AV *3)	PK
IF Bandwidth	BW 120 kHz	RBW: 1 MHz VBW: 3 MHz	Average Power Method: RBW: 1 MHz VBW: 3 MHz Detector: Power Averaging (RMS) Trace: 100 traces If duty cycle was less than 98%, a duty factor was added to the results.	RBW: 100 kHz VBW: 300kHz
Test Distance	3 m	3.75 m *1) (1 GHz – 10 GHz), 1.0 m *2) (10 GHz – 26.5 GHz)		3.75 m *1) (1 GHz – 10 GHz), 1.0 m *2) (10 GHz – 26.5 GHz)

\*1) Distance Factor:  $20 \times \log(3.75 \text{ m} / 3.0 \text{ m}) = 1.94 \text{ dB}$

\*2) Distance Factor:  $20 \times \log(1.0 \text{ m} / 3.0 \text{ m}) = -9.5 \text{ dB}$

\*3) Average Power Measurement was performed based on 6.0 & 12.2.5 of "KDB 558074 D01 DTS Meas Guidance v03r05"

- The carrier level and noise levels were confirmed at each position of X, Y and Z axes of EUT to see the position of maximum noise, and the test was made at the position that has the maximum noise.

The test results and limit are rounded off to one decimal place, so some differences might be observed.

**Measurement range : 30 MHz - 26.5 GHz**  
**Test data : APPENDIX**  
**Test result : Pass**

## **SECTION 6: Antenna Terminal Conducted Tests**

### **Test Procedure**

The tests were made with below setting connected to the antenna port.

<b>Test</b>	<b>Span</b>	<b>RBW</b>	<b>VBW</b>	<b>Sweep time</b>	<b>Detector</b>	<b>Trace</b>	<b>Instrument used</b>
6dB Bandwidth	3 MHz	100 kHz	300 kHz	Auto	Peak	Max Hold	Spectrum Analyzer
99% Occupied Bandwidth *1)	Enough width to display emission skirts	1 to 5 % of OBW	Three times of RBW	Auto	Peak	Max Hold	Spectrum Analyzer
Maximum Peak Output Power	-	-	-	Auto	Peak/Average *2)	-	Power Meter (Sensor: 50 MHz BW)
Peak Power Density	1.5 times the 6dB Bandwidth	3 kHz	10 kHz	Auto	Peak	Max Hold	Spectrum Analyzer *3)
Conducted Spurious Emission *4)	9kHz to 150kHz	200 Hz	620 Hz	Auto	Peak	Max Hold	Spectrum Analyzer
	150kHz to 30MHz	9.1 kHz	27 kHz				

\*1) Peak hold was applied as Worst-case measurement.

\*2) Reference data

\*3) Section 10.2 Method PKPSD (peak PSD) of "KDB 558074 D01 DTS Meas Guidance v03r05".

\*4) In the frequency range below 30MHz, RBW was narrowed to separate the noise contents.

Then, wide-band noise near the limit was checked separately, however the noise was not detected as shown in the chart.  
(9 kHz - 150 kHz: RBW = 200 Hz, 150 kHz - 30 MHz: RBW = 9.1 kHz)

The test results and limit are rounded off to two decimals place, so some differences might be observed.

**Test data : APPENDIX**

**Test result : Pass**

**UL Japan, Inc.**

**Ise EMC Lab.**

4383-326 Asama-cho, Ise-shi, Mie-ken 516-0021 JAPAN

Telephone : +81 596 24 8999

Facsimile : +81 596 24 8124

**APPENDIX 1: Test data**

**6dB Bandwidth**

Test place Ise EMC Lab. No.6 Shielded Room  
Report No. 11347427H  
Date August 23, 2016  
Temperature / Humidity 25 deg. C / 52 % RH  
Engineer Takafumi Noguchi  
Mode Tx

Mode	Frequency [MHz]	6dB Bandwidth [MHz]	Limit [kHz]
BT LE	2402	0.656	> 500
	2440	0.658	> 500
	2480	0.644	> 500

## 6dB Bandwidth

### BT LE

#### 2402 MHz

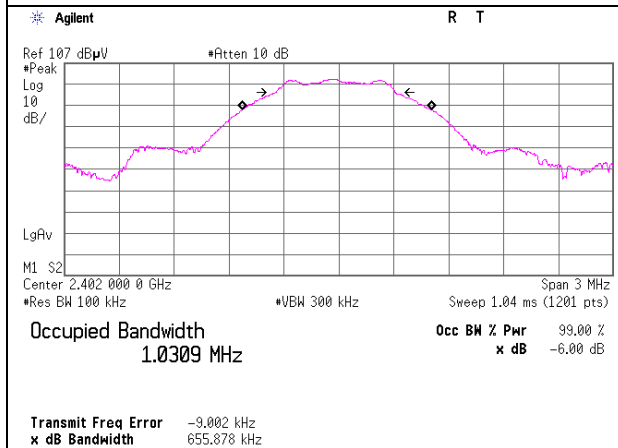

#### 2440 MHz

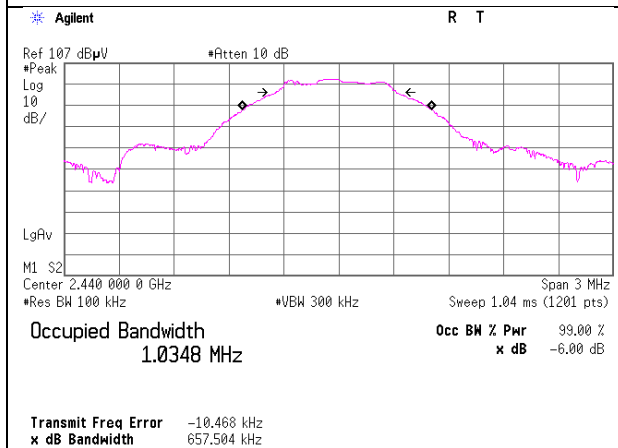

#### 2480 MHz

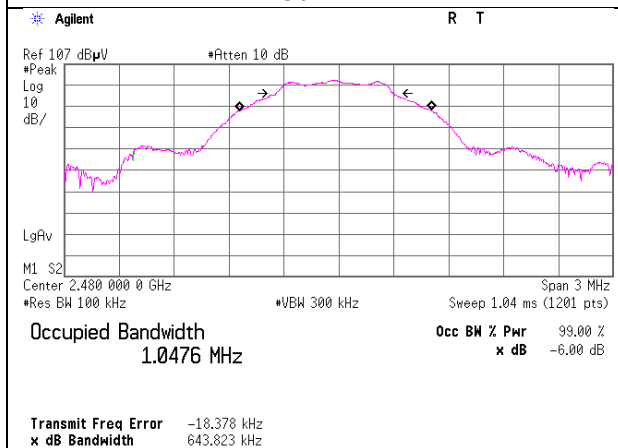

### Maximum Peak Output Power

Test place Ise EMC Lab. No.6 Shielded Room  
Report No. 11347427H  
Date August 23, 2016  
Temperature / Humidity 25 deg. C / 52 % RH  
Engineer Takafumi Noguchi  
Mode Tx BT LE

Freq. [MHz]	Reading [dBm]	Cable Loss [dB]	Atten. Loss [dB]	Result		Limit		Margin [dB]
				[dBm]	[mW]	[dBm]	[mW]	
2402	-7.87	1.46	10.08	3.67	2.33	30.00	1000	26.33
2440	-7.76	1.47	10.08	3.79	2.39	30.00	1000	26.21
2480	-7.79	1.48	10.08	3.77	2.38	30.00	1000	26.23

Sample Calculation:

Result = Reading + Cable Loss (including the cable(s) customer supplied) + Attenuator Loss

**Average Output Power**  
**(Reference data for RF Exposure)**

Test place : Ise EMC Lab. No.6 Shielded Room  
Report No. : 11347427H  
Date : August 23, 2016  
Temperature / Humidity : 25 deg. C / 52 % RH  
Engineer : Takafumi Noguchi  
Mode : Tx

BT LE

Freq. [MHz]	Reading [dBm]	Cable Loss [dB]	Atten. Loss [dB]	Result (Time average)		Duty factor [dB]	Result (Burst power average)	
				[dBm]	[mW]		[dBm]	[mW]
2402	-8.18	1.46	10.08	3.36	2.17	0.17	3.53	2.25
2440	-8.06	1.47	10.08	3.49	2.23	0.17	3.66	2.32
2480	-8.10	1.48	10.08	3.46	2.22	0.17	3.63	2.31

Sample Calculation:

Result (Time average) = Reading + Cable Loss (including the cable(s) customer supplied) + Attenuator

Result (Burst power average) = Frame power + Duty factor



## Burst rate confirmation

Test place	Ise EMC Lab. No.2 Measurement Room
Report No.	11347427H
Date	August 19, 2016
Temperature / Humidity	24 deg. C / 62 % RH
Engineer	Satofumi Matsuyama
Mode	Tx BT LE

### BLE

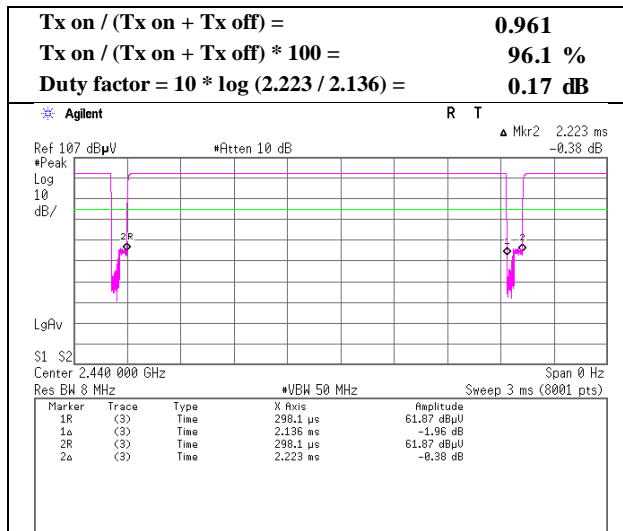

## Radiated Spurious Emission

Test place : Ise EMC Lab. No.2 Semi Anechoic Chamber  
Report No. : 11347427H  
Date : August 19, 2016 August 19, 2016  
Temperature / Humidity : 24 deg. C / 62 % RH 23 deg. C / 55 % RH  
Engineer : Satofumi Matsuyama Koji Yamamoto  
(Above 1GHz) (Below 1GHz)  
Mode : Tx BT LE 2402 MHz

Polarity	Frequency [MHz]	Detector	Reading [dBuV]	Ant.Fac. [dB/m]	Loss [dB]	Gain [dB]	Duty Factor [dB]	Result [dBuV/m]	Limit [dBuV/m]	Margin [dB]	Remark
Hori	32.768	QP	24.0	16.4	6.7	28.5	-	18.6	40.0	21.4	
Hori	131.072	QP	22.7	13.8	7.7	28.0	-	16.2	43.5	27.3	
Hori	163.840	QP	22.7	15.2	7.9	27.9	-	17.9	43.5	25.6	
Hori	196.608	QP	22.5	16.4	8.1	27.7	-	19.3	43.5	24.2	
Hori	655.360	QP	22.6	19.4	10.3	28.2	-	24.1	46.0	21.9	
Hori	917.504	QP	21.8	21.9	11.2	27.3	-	27.6	46.0	18.4	
Hori	2338.558	PK	57.7	27.6	4.6	34.8	-	55.1	73.9	18.8	
Hori	2390.000	PK	51.8	27.6	4.6	34.8	-	49.2	73.9	24.7	
Hori	4804.000	PK	42.9	31.5	6.5	34.1	-	46.8	73.9	27.1	Floor noise
Hori	7206.000	PK	45.0	36.1	7.3	34.1	-	54.3	73.9	19.6	
Hori	9608.000	PK	44.7	38.5	8.0	34.8	-	56.4	73.9	17.5	Floor noise
Hori	2338.558	AV	40.9	27.6	4.6	34.8	0.2	38.5	53.9	15.4	
Hori	2390.000	AV	38.2	27.6	4.6	34.8	0.2	35.8	53.9	18.1	*1)
Hori	4804.000	AV	34.2	31.5	6.5	34.1	-	38.1	53.9	15.8	Floor noise
Hori	7206.000	AV	36.6	36.1	7.3	34.1	0.2	46.1	53.9	7.8	
Hori	9608.000	AV	36.1	38.5	8.0	34.8	-	47.8	53.9	6.1	Floor noise
Vert	32.768	QP	23.8	16.4	6.7	28.5	-	18.4	40.0	21.6	
Vert	131.072	QP	22.8	13.8	7.7	28.0	-	16.3	43.5	27.2	
Vert	163.840	QP	23.0	15.2	7.9	27.9	-	18.2	43.5	25.3	
Vert	196.608	QP	22.8	16.4	8.1	27.7	-	19.6	43.5	23.9	
Vert	655.360	QP	22.5	19.4	10.3	28.2	-	24.0	46.0	22.0	
Vert	917.504	QP	22.1	21.9	11.2	27.3	-	27.9	46.0	18.1	
Vert	2337.668	PK	58.1	27.6	4.6	34.8	-	55.5	73.9	18.4	
Vert	2390.000	PK	52.7	27.6	4.6	34.8	-	50.1	73.9	23.8	
Vert	4804.000	PK	42.7	31.5	6.5	34.1	-	46.6	73.9	27.3	Floor noise
Vert	7206.000	PK	45.3	36.1	7.3	34.1	-	54.6	73.9	19.3	
Vert	9608.000	PK	44.6	38.5	8.0	34.8	-	56.3	73.9	17.6	Floor noise
Vert	2337.668	AV	41.4	27.6	4.6	34.8	0.2	39.0	53.9	14.9	
Vert	2390.000	AV	38.5	27.6	4.6	34.8	0.2	36.1	53.9	17.8	*1)
Vert	4804.000	AV	34.2	31.5	6.5	34.1	-	38.1	53.9	15.8	Floor noise
Vert	7206.000	AV	37.2	36.1	7.3	34.1	0.2	46.7	53.9	7.2	
Vert	9608.000	AV	36.1	38.5	8.0	34.8	-	47.8	53.9	6.1	Floor noise

Result = Reading + Ant Factor + Loss (Cable+Attenuator+Filter+Distance factor(above 1 GHz)) - Gain(Amplifier) + Duty factor

\*Other frequency noises omitted in this report were not seen or had enough margin (more than 20 dB).

Distance factor: 1 GHz - 10 GHz 20log (3.75 m / 3.0 m) = 1.94 dB

10 GHz - 26.5 GHz 20log (1.0 m / 3.0 m) = -9.5 dB

\*1) Not Out of Band emission(Leakage Power)

### 20dBc Data Sheet

Polarity	Frequency [MHz]	Detector	Reading [dBuV]	Ant Factor [dB/m]	Loss [dB]	Gain [dB]	Result [dBuV/m]	Limit [dBuV/m]	Margin [dB]	Remark
Hori	2402.000	PK	99.6	27.6	4.6	34.8	97.0	-	-	Carrier
Hori	2400.000	PK	56.7	27.6	4.6	34.8	54.1	77.0	22.9	
Vert	2402.000	PK	100.6	27.6	4.6	34.8	98.0	-	-	Carrier
Vert	2400.000	PK	61.6	27.6	4.6	34.8	59.0	78.0	19.0	

Result = Reading + Ant Factor + Loss (Cable+Attenuator+Filter+Distance factor(above 1 GHz)) - Gain(Amplifier)

**Radiated Spurious Emission**  
**(Reference Plot for band-edge)**

Test place : Ise EMC Lab. No.2 Semi Anechoic Chamber  
Report No. : 11347427H  
Date : August 19, 2016  
Temperature / Humidity : 24 deg. C / 62 % RH  
Engineer : Satofumi Matsuyama  
Mode : Tx BT LE 2402 MHz

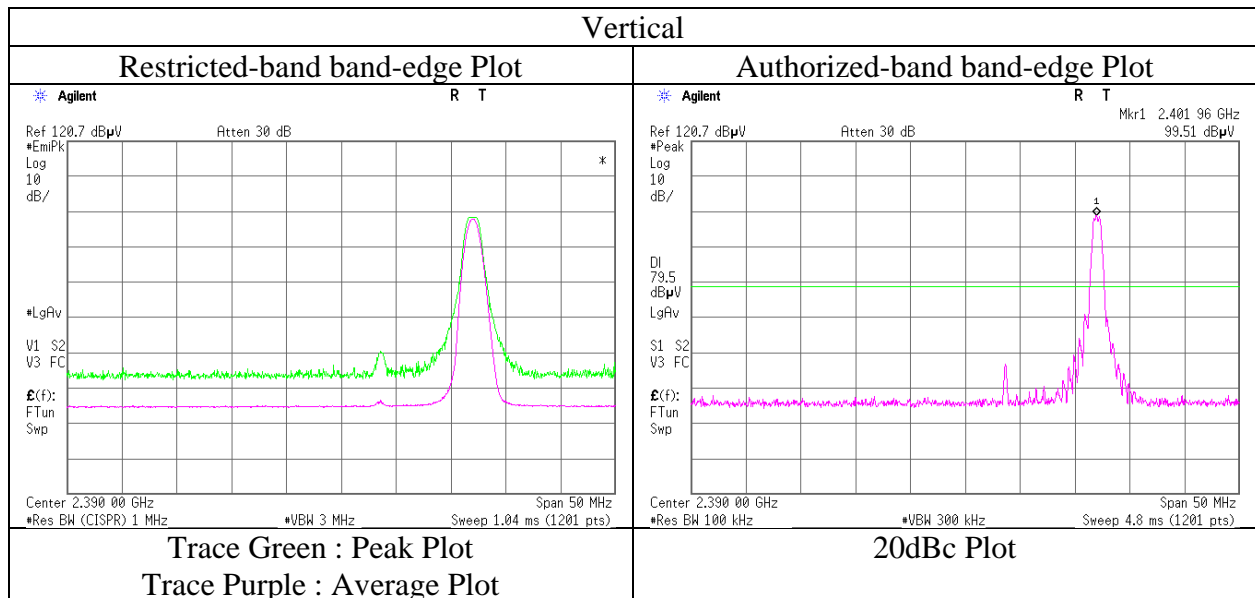
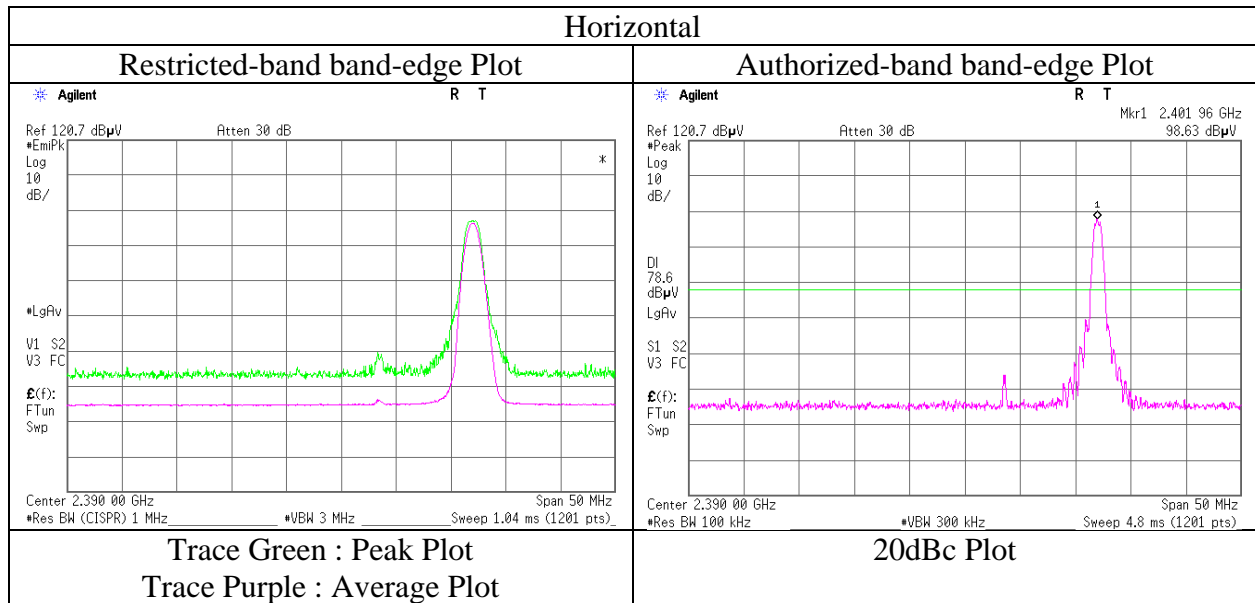

\* Final result of restricted band edge was shown in tabular data.

## Radiated Spurious Emission

Test place : Ise EMC Lab. No.2 Semi Anechoic Chamber  
Report No. : 11347427H  
Date : August 19, 2016 August 19, 2016  
Temperature / Humidity : 24 deg. C / 62 % RH 23 deg. C / 55 % RH  
Engineer : Satofumi Matsuyama Koji Yamamoto  
(Above 1GHz) (Below 1GHz)  
Mode : Tx BT LE 2440 MHz

Polarity	Frequency [MHz]	Detector	Reading [dBuV]	Ant.Fac. [dB/m]	Loss [dB]	Gain [dB]	Duty Factor [dB]	Result [dBuV/m]	Limit [dBuV/m]	Margin [dB]	Remark
Hori	32.768	QP	24.1	16.4	6.7	28.5	-	18.7	40.0	21.3	
Hori	131.072	QP	22.7	13.8	7.7	28.0	-	16.2	43.5	27.3	
Hori	163.840	QP	22.5	15.2	7.9	27.9	-	17.7	43.5	25.8	
Hori	196.608	QP	22.5	16.4	8.1	27.7	-	19.3	43.5	24.2	
Hori	655.360	QP	22.3	19.4	10.3	28.2	-	23.8	46.0	22.2	
Hori	917.504	QP	21.6	21.9	11.2	27.3	-	27.4	46.0	18.6	
Hori	2338.558	PK	57.2	27.6	4.6	34.8	-	54.6	73.9	19.3	
Hori	4880.000	PK	42.1	31.7	6.5	34.1	-	46.2	73.9	27.7	Floor noise
Hori	7320.000	PK	41.8	36.3	7.3	34.1	-	51.3	73.9	22.6	Floor noise
Hori	9760.000	PK	44.3	38.5	8.0	34.8	-	56.0	73.9	17.9	Floor noise
Hori	2338.558	AV	41.7	27.6	4.6	34.8	0.2	39.3	53.9	14.6	
Hori	4880.000	AV	33.8	31.7	6.5	34.1	-	37.9	53.9	16.0	Floor noise
Hori	7320.000	AV	32.9	36.3	7.3	34.1	-	42.4	53.9	11.5	Floor noise
Hori	9760.000	AV	35.3	38.5	8.0	34.8	-	47.0	53.9	6.9	Floor noise
Vert	32.768	QP	24.0	16.4	6.7	28.5	-	18.6	40.0	21.4	
Vert	131.072	QP	22.8	13.8	7.7	28.0	-	16.3	43.5	27.2	
Vert	163.840	QP	22.8	15.2	7.9	27.9	-	18.0	43.5	25.5	
Vert	196.608	QP	22.6	16.4	8.1	27.7	-	19.4	43.5	24.1	
Vert	655.360	QP	22.5	19.4	10.3	28.2	-	24.0	46.0	22.0	
Vert	917.504	QP	21.5	21.9	11.2	27.3	-	27.3	46.0	18.7	
Vert	2337.611	PK	58.5	27.6	4.6	34.8	-	55.9	73.9	18.0	
Vert	4880.000	PK	42.2	31.7	6.5	34.1	-	46.3	73.9	27.6	Floor noise
Vert	7320.000	PK	42.1	36.3	7.3	34.1	-	51.6	73.9	22.3	Floor noise
Vert	9760.000	PK	44.5	38.5	8.0	34.8	-	56.2	73.9	17.7	Floor noise
Vert	2337.611	AV	42.0	27.6	4.6	34.8	0.2	39.6	53.9	14.3	
Vert	4880.000	AV	33.8	31.7	6.5	34.1	-	37.9	53.9	16.0	Floor noise
Vert	7320.000	AV	32.9	36.3	7.3	34.1	-	42.4	53.9	11.5	Floor noise
Vert	9760.000	AV	35.3	38.5	8.0	34.8	-	47.0	53.9	6.9	Floor noise

Result = Reading + Ant Factor + Loss (Cable+Attenuator+Filter+Distance factor(above 1 GHz)) - Gain(Amplifier) + Duty factor

\*Other frequency noises omitted in this report were not seen or had enough margin (more than 20 dB).

Distance factor: 1 GHz - 10 GHz 20log (3.75 m / 3.0 m) = 1.94 dB  
10 GHz - 26.5 GHz 20log (1.0 m / 3.0 m) = -9.5 dB

### 20dBc Data Sheet

Polarity	Frequency [MHz]	Detector	Reading [dBuV]	Ant Factor [dB/m]	Loss [dB]	Gain [dB]	Result [dBuV/m]	Limit [dBuV/m]	Margin [dB]	Remark
Hori	2440.000	PK	99.2	27.7	4.6	34.7	96.8	-	-	Carrier
Hori	2393.841	PK	53.4	27.6	4.6	34.8	50.8	76.8	26.0	
Vert	2440.000	PK	100.8	27.7	4.6	34.7	98.4	-	-	Carrier
Vert	2393.841	PK	54.6	27.6	4.6	34.8	52.0	78.4	26.4	

Result = Reading + Ant Factor + Loss (Cable+Attenuator+Filter+Distance factor(above 1 GHz)) - Gain(Amplifier)

**UL Japan, Inc.**

**Ise EMC Lab.**

4383-326 Asama-cho, Ise-shi, Mie-ken 516-0021 JAPAN

Telephone : +81 596 24 8999

Facsimile : +81 596 24 8124

## Radiated Spurious Emission

Test place : Ise EMC Lab. No.2 Semi Anechoic Chamber  
Report No. : 11347427H  
Date : August 19, 2016 August 19, 2016  
Temperature / Humidity : 24 deg. C / 62 % RH 23 deg. C / 55 % RH  
Engineer : Satofumi Matsuyama Koji Yamamoto  
(Above 1GHz) (Below 1GHz)  
Mode : Tx BT LE 2480 MHz

Polarity	Frequency [MHz]	Detector	Reading [dBuV]	Ant.Fac. [dB/m]	Loss [dB]	Gain [dB]	Duty Factor [dB]	Result [dBuV/m]	Limit [dBuV/m]	Margin [dB]	Remark
Hori	32.768	QP	23.9	16.4	6.7	28.5	-	18.5	40.0	21.5	
Hori	131.072	QP	22.6	13.8	7.7	28.0	-	16.1	43.5	27.4	
Hori	163.840	QP	23.1	15.2	7.9	27.9	-	18.3	43.5	25.2	
Hori	196.608	QP	22.5	16.4	8.1	27.7	-	19.3	43.5	24.2	
Hori	655.360	QP	22.6	19.4	10.3	28.2	-	24.1	46.0	21.9	
Hori	917.504	QP	21.9	21.9	11.2	27.3	-	27.7	46.0	18.3	
Hori	2483.500	PK	60.0	27.7	4.7	34.7	-	57.7	73.9	16.2	
Hori	4960.000	PK	41.4	32.0	6.5	34.2	-	45.7	73.9	28.2	Floor noise
Hori	7440.000	PK	45.0	36.4	7.4	34.1	-	54.7	73.9	19.2	
Hori	9920.000	PK	45.8	38.6	8.1	34.9	-	57.6	73.9	16.3	Floor noise
Hori	2483.500	AV	43.2	27.7	4.7	34.7	0.2	41.1	53.9	12.8	*1)
Hori	4960.000	AV	33.3	32.0	6.5	34.2	-	37.6	53.9	16.3	Floor noise
Hori	7440.000	AV	36.6	36.4	7.4	34.1	0.2	46.5	53.9	7.4	
Hori	9920.000	AV	35.9	38.6	8.1	34.9	-	47.7	53.9	6.2	Floor noise
Vert	32.768	QP	23.8	16.4	6.7	28.5	-	18.4	40.0	21.6	
Vert	131.072	QP	23.2	13.8	7.7	28.0	-	16.7	43.5	26.8	
Vert	163.840	QP	22.7	15.2	7.9	27.9	-	17.9	43.5	25.6	
Vert	196.608	QP	22.5	16.4	8.1	27.7	-	19.3	43.5	24.2	
Vert	655.360	QP	22.2	19.4	10.3	28.2	-	23.7	46.0	22.3	
Vert	917.504	QP	21.8	21.9	11.2	27.3	-	27.6	46.0	18.4	
Vert	2483.500	PK	61.8	27.7	4.7	34.7	-	59.5	73.9	14.4	
Vert	4960.000	PK	41.9	32.0	6.5	34.2	-	46.2	73.9	27.7	Floor noise
Vert	7440.000	PK	42.1	36.4	7.4	34.1	-	51.8	73.9	22.1	Floor noise
Vert	9920.000	PK	44.8	38.6	8.1	34.9	-	56.6	73.9	17.3	Floor noise
Vert	2483.500	AV	44.2	27.7	4.7	34.7	0.2	42.1	53.9	11.8	*1)
Vert	4960.000	AV	33.3	32.0	6.5	34.2	-	37.6	53.9	16.3	Floor noise
Vert	7440.000	AV	34.1	36.4	7.4	34.1	-	43.8	53.9	10.1	Floor noise
Vert	9920.000	AV	35.9	38.6	8.1	34.9	-	47.7	53.9	6.2	Floor noise

Result = Reading + Ant Factor + Loss (Cable+Attenuator+Filter+Distance factor(above 1 GHz)) - Gain(Amplifier) + Duty factor

\*Other frequency noises omitted in this report were not seen or had enough margin (more than 20 dB).

Distance factor: 1 GHz - 10 GHz 20log (3.75 m / 3.0 m) = 1.94 dB  
10 GHz - 26.5 GHz 20log (1.0 m / 3.0 m) = -9.5 dB

\*1) Not Out of Band emission(Leakage Power)

### 20dBc Data Sheet

Polarity	Frequency [MHz]	Detector	Reading [dBuV]	Ant Factor [dB/m]	Loss [dB]	Gain [dB]	Result [dBuV/m]	Limit [dBuV/m]	Margin [dB]	Remark
Hori	2480.000	PK	100.1	27.7	4.7	34.7	97.8	-	-	Carrier
Hori	2514.510	PK	58.4	27.7	4.7	34.7	56.1	77.8	21.7	
Vert	2480.000	PK	102.3	27.7	4.7	34.7	100.0	-	-	Carrier
Vert	2514.510	PK	59.4	27.7	4.7	34.7	57.1	80.0	22.9	

Result = Reading + Ant Factor + Loss (Cable+Attenuator+Filter+Distance factor(above 1 GHz)) - Gain(Amplifier)

**UL Japan, Inc.**

**Ise EMC Lab.**

4383-326 Asama-cho, Ise-shi, Mie-ken 516-0021 JAPAN

Telephone : +81 596 24 8999

Facsimile : +81 596 24 8124

**Radiated Spurious Emission**  
**(Reference Plot for band-edge)**

Test place : Ise EMC Lab. No.2 Semi Anechoic Chamber  
Report No. : 11347427H  
Date : August 19, 2016  
Temperature / Humidity : 24 deg. C / 62 % RH  
Engineer : Satofumi Matsuyama  
Mode : Tx BT LE 2480 MHz

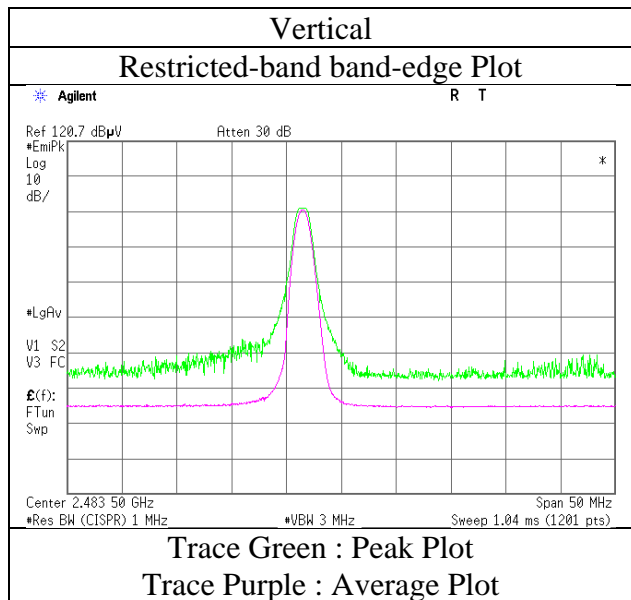
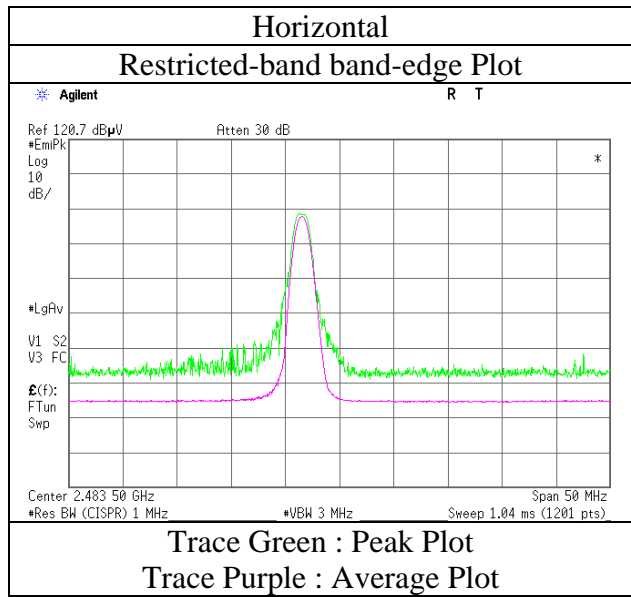

\* Final result of restricted band edge was shown in tabular data.

**Radiated Spurious Emission**  
**(Plot data, Worst case)**

Test place	Ise EMC Lab. No.2 Semi Anechoic Chamber	
Report No.	11347427H	
Date	August 19, 2016	August 19, 2016
Temperature / Humidity	24 deg. C / 62 % RH	23 deg. C / 55 % RH
Engineer	Satofumi Matsuyama (Above 1GHz)	Koji Yamamoto (Below 1GHz)
Mode	Tx BT LE 2440 MHz	

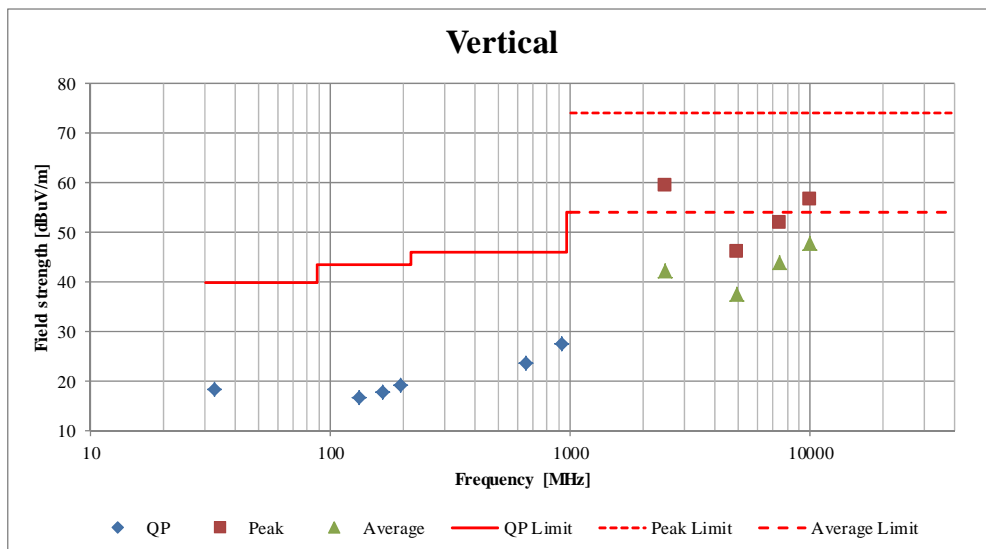
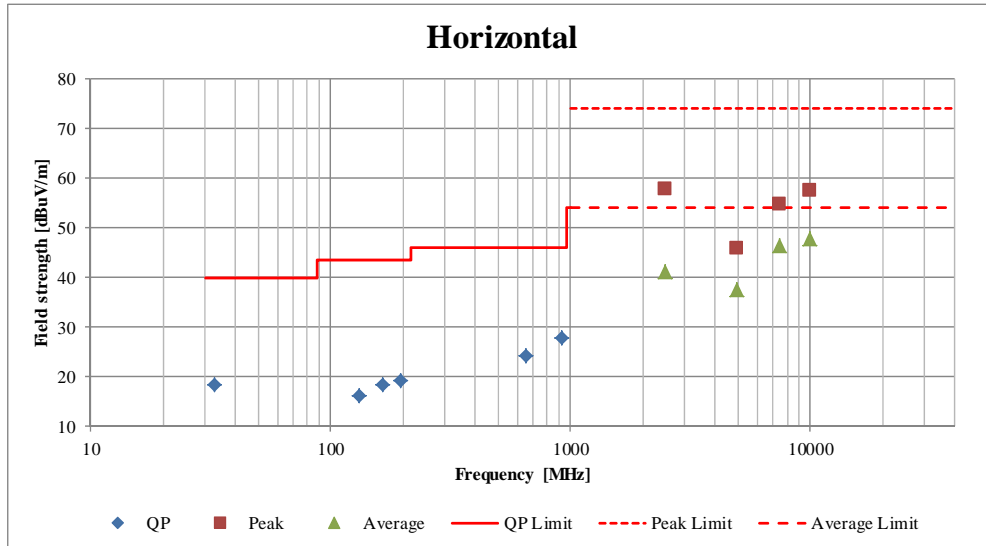

\*These plots data contains sufficient number to show the trend of characteristic features for EUT.

## Conducted Spurious Emission

Test place	Ise EMC Lab. No.6 Shielded Room
Report No.	11347427H
Date	August 23, 2016
Temperature / Humidity	25 deg. C / 52 % RH
Engineer	Takafumi Noguchi
Mode	Tx BT LE 2402 MHz

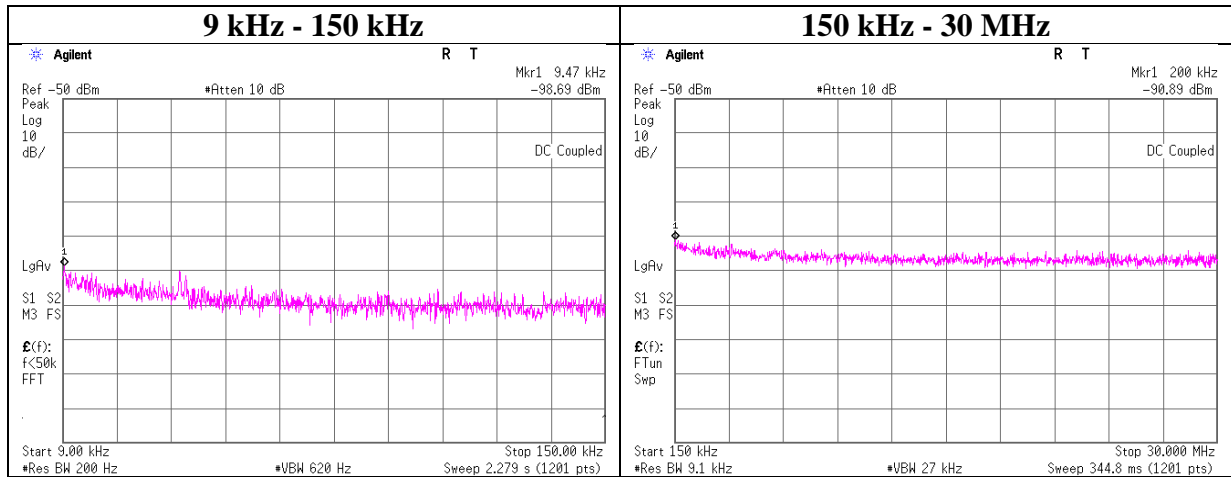

Frequency [kHz]	Reading [dBm]	Cable Loss [dB]	Attenuator Loss [dB]	Antenna Gain [dBi]	N (Number of Output)	EIRP [dBm]	Distance [m]	Ground bounce [dB]	E (field strength) [dBuV/m]	Limit [dBuV/m]	Margin [dB]	Remark
9.47	-98.7	0.10	9.8	2.0	1	-86.8	300	6.0	-25.5	48.0	73.5	
200.00	-90.9	0.11	9.8	2.0	1	-78.9	300	6.0	-17.7	21.5	39.2	

$E = \text{EIRP} - 20 \log(D) + \text{Ground bounce} + 104.8 \text{ [dBuV/m]}$

$\text{EIRP} = \text{Reading} + \text{Cable Loss} + \text{Attenuator Loss} + \text{Antenna Gain} + 10 * \log(N)$

**UL Japan, Inc.**

**Ise EMC Lab.**

4383-326 Asama-cho, Ise-shi, Mie-ken 516-0021 JAPAN

Telephone : +81 596 24 8999

Facsimile : +81 596 24 8124



## Conducted Spurious Emission

Test place	Ise EMC Lab. No.6 Shielded Room
Report No.	11347427H
Date	August 23, 2016
Temperature / Humidity	25 deg. C / 52 % RH
Engineer	Takafumi Noguchi
Mode	Tx BT LE 2440 MHz

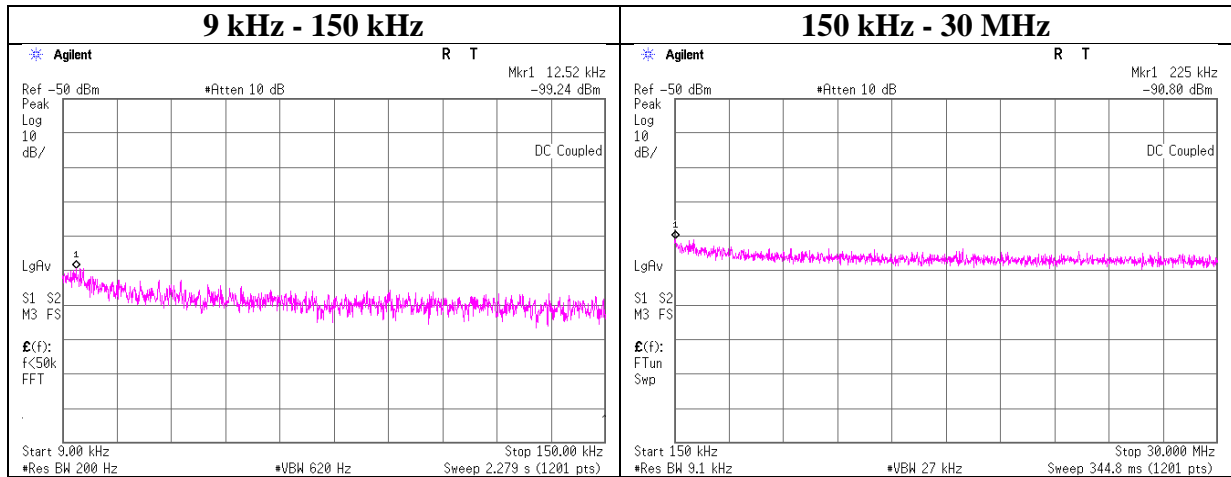

Frequency [kHz]	Reading [dBm]	Cable Loss [dB]	Attenuator Loss [dB]	Antenna Gain [dBi]	N (Number of Output)	EIRP [dBm]	Distance [m]	Ground bounce [dB]	E (field strength) [dBuV/m]	Limit [dBuV/m]	Margin [dB]	Remark
12.52	-99.2	0.10	9.8	2.0	1	-87.3	300	6.0	-26.1	45.6	71.7	
225.00	-90.8	0.11	9.9	2.0	1	-78.8	300	6.0	-17.6	20.5	38.1	

$E = \text{EIRP} - 20 \log(D) + \text{Ground bounce} + 104.8 \text{ [dBuV/m]}$

$\text{EIRP} = \text{Reading} + \text{Cable Loss} + \text{Attenuator Loss} + \text{Antenna Gain} + 10 * \log(N)$

**UL Japan, Inc.**

**Ise EMC Lab.**

4383-326 Asama-cho, Ise-shi, Mie-ken 516-0021 JAPAN

Telephone : +81 596 24 8999

Facsimile : +81 596 24 8124

## Conducted Spurious Emission

Test place	Ise EMC Lab. No.6 Shielded Room
Report No.	11347427H
Date	August 23, 2016
Temperature / Humidity	25 deg. C / 52 % RH
Engineer	Takafumi Noguchi
Mode	Tx BT LE 2480 MHz

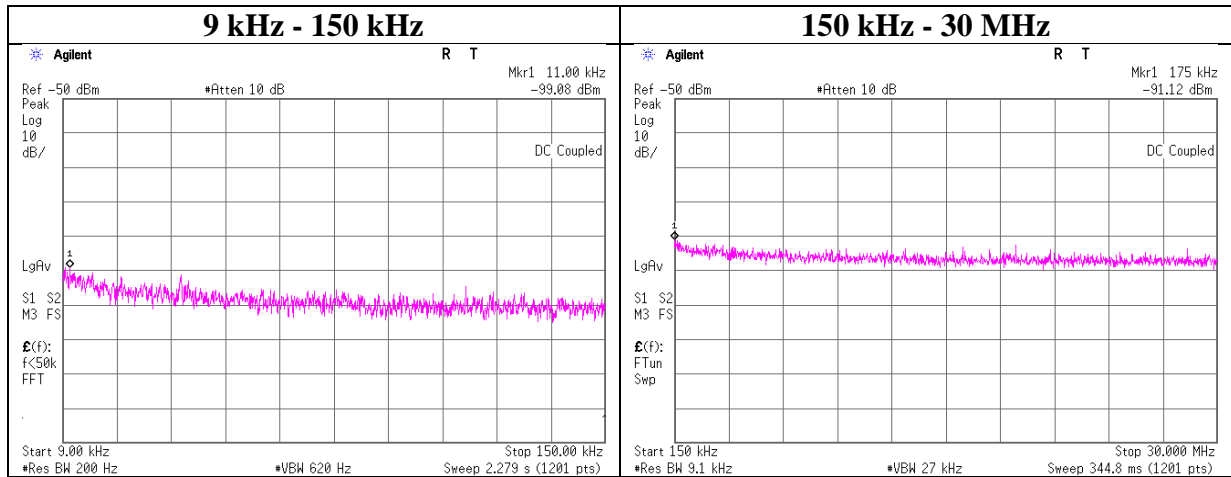

Frequency [kHz]	Reading [dBm]	Cable Loss [dB]	Attenuator Loss [dB]	Antenna Gain [dBi]	N (Number of Output)	EIRP [dBm]	Distance [m]	Ground bounce [dB]	E (field strength) [dBuV/m]	Limit [dBuV/m]	Margin [dB]	Remark
11.00	-99.1	0.10	9.8	2.0	1	-87.2	300	6.0	-25.9	46.7	72.6	
175.00	-91.1	0.10	9.8	2.0	1	-79.2	300	6.0	-17.9	22.7	40.6	

$E = \text{EIRP} - 20 \log(D) + \text{Ground bounce} + 104.8 \text{ [dBuV/m]}$

$\text{EIRP} = \text{Reading} + \text{Cable Loss} + \text{Attenuator Loss} + \text{Antenna Gain} + 10 * \log(N)$

### Power Density

Test place Ise EMC Lab. No.6 Shielded Room  
Report No. 11347427H  
Date August 23, 2016  
Temperature / Humidity 25 deg. C / 52 % RH  
Engineer Takafumi Noguchi  
Mode Tx

#### BT LE

Freq. [MHz]	Reading [dBm]	Cable Loss [dB]	Atten. Loss [dB]	Result [dBm]	Limit [dBm]	Margin [dB]
2402	-19.68	1.46	10.08	-8.14	8.00	16.14
2440	-19.81	1.47	10.08	-8.26	8.00	16.26
2480	-19.81	1.48	10.08	-8.25	8.00	16.25

Sample Calculation:

Result = Reading + Cable Loss (including the cable(s) customer supplied) + Attenuator

## Power Density

### BT LE

#### 2402 MHz

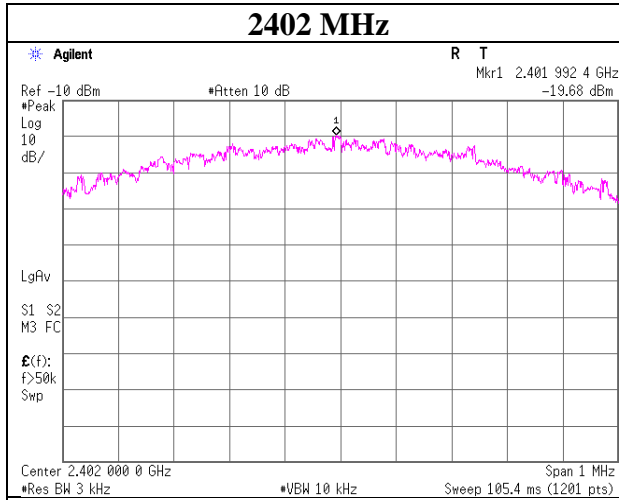

#### 2440 MHz

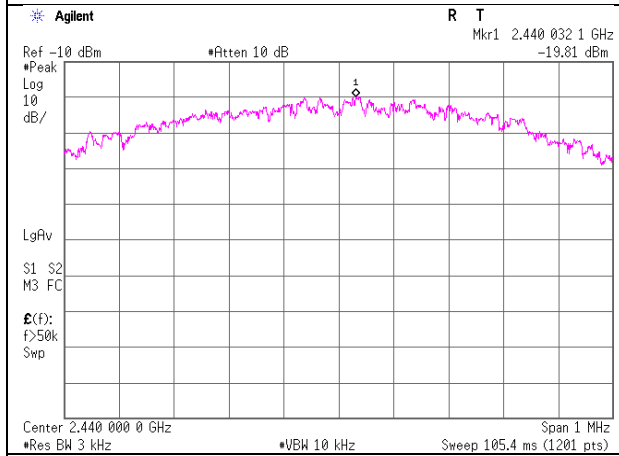

#### 2480 MHz

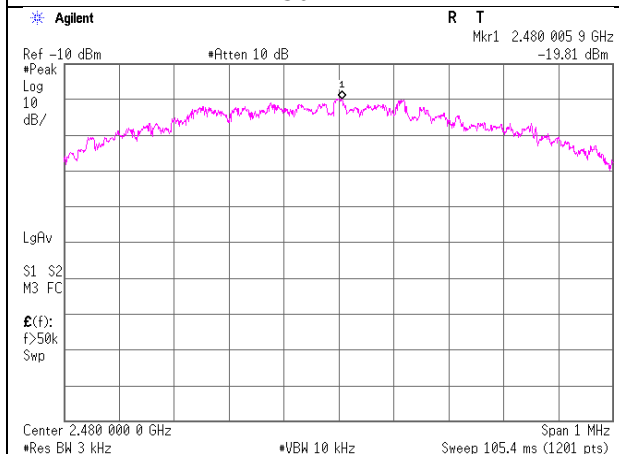

## 99% Occupied Bandwidth

Test place	Ise EMC Lab. No.6 Shielded Room
Report No.	11347427H
Date	August 23, 2016
Temperature / Humidity	25 deg. C / 52 % RH
Engineer	Takafumi Noguchi
Mode	Tx

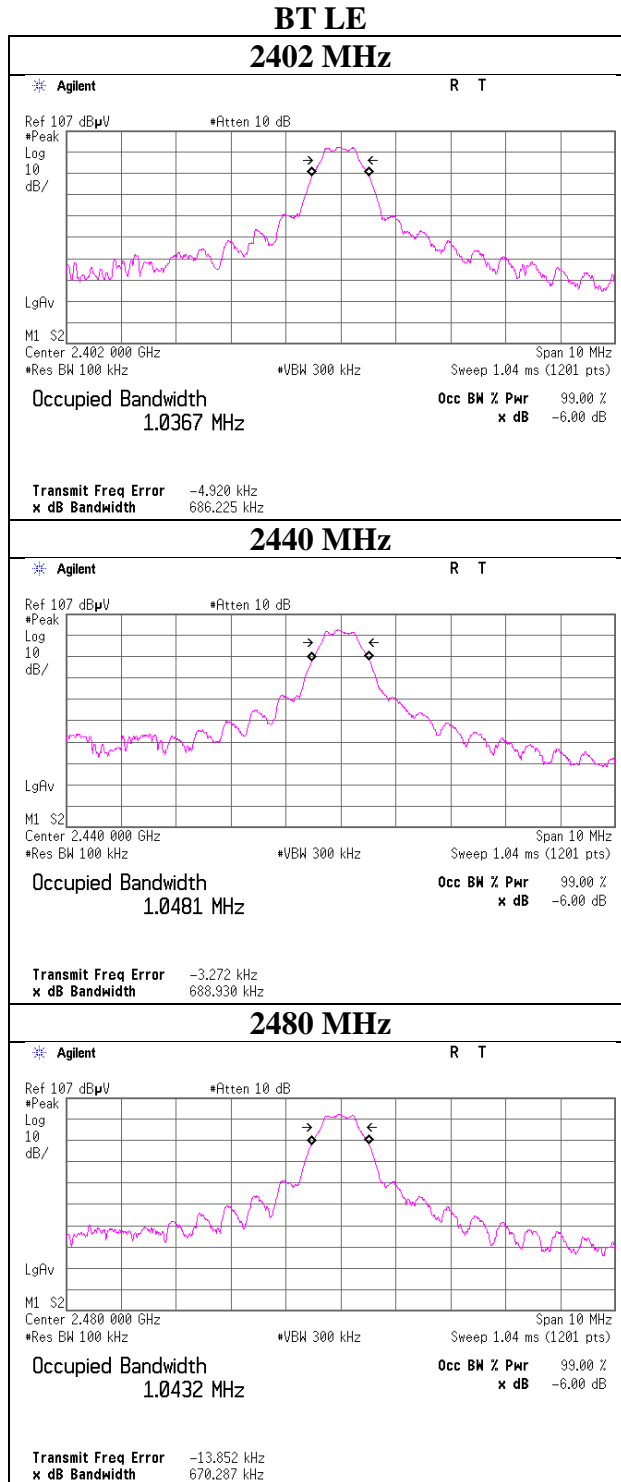

**UL Japan, Inc.**

**Ise EMC Lab.**

4383-326 Asama-cho, Ise-shi, Mie-ken 516-0021 JAPAN

Telephone : +81 596 24 8999

Facsimile : +81 596 24 8124

## **APPENDIX 2: Test instruments**

### **Test equipment**

Control No.	Instrument	Manufacturer	Model No	Serial No	Test Item	Calibration Date * Interval(month)
MAEC-02	Semi Anechoic Chamber(NSA)	TDK	Semi Anechoic Chamber 3m	DA-06902	RE	2016/08/02 * 12
MOS-22	Thermo-Hygrometer	Custom	CTH-201	0003	RE	2016/01/21 * 12
MJM-14	Measure	KOMELON	KMC-36	-	RE	-
COTS-MEMI	EMI measurement program	TSJ	TEPTO-DV	-	RE	-
MSA-04	Spectrum Analyzer	Agilent	E4448A	US44300523	RE	2015/11/06 * 12
MTR-03	Test Receiver	Rohde & Schwarz	ESCI	100300	RE	2015/10/11 * 12
KBA-05	Biconical Antenna	Schwarzbeck	BBA9106	2513	RE	2015/11/02 * 12
MLA-21	Logperiodic Antenna(200-1000MHz)	Schwarzbeck	VUSLP9111B	911B-190	RE	2016/01/30 * 12
MCC-12	Coaxial Cable	Fujikura/Agilent	-	-	RE	2016/02/08 * 12
MAT-07	Attenuator(6dB)	Weinschel Corp	2	BK7970	RE	2015/11/10 * 12
MPA-09	Pre Amplifier	Agilent	8447D	2944A10845	RE	2015/09/04 * 12
MMM-01	Digital Tester	Fluke	FLUKE 26-3	78030611	RE	2015/08/19 * 12
MHA-06	Horn Antenna 1-18GHz	Schwarzbeck	BBHA9120D	254	RE	2016/02/29 * 12
MCC-167	Microwave Cable	Junkosha	MWX221	1404S374(1m) / 1405S074(5m)	RE	2016/05/20 * 12
MPA-10	Pre Amplifier	Agilent	8449B	3008A02142	RE	2016/01/19 * 12
MHA-02	Horn Antenna 18-26.5GHz	EMCO	3160-09	1265	RE	2016/02/29 * 12
MHF-06	High Pass Filter 3.5-24GHz	TOKIMEC	TF323DCA	601	RE	2016/05/16 * 12
MCC-137	Microwave cable	HUBER+SUHNER	SUCOFLEX 102	37954/2	AT	2015/10/08 * 12
MCC-38	Coaxial Cable	UL Japan	-	-	AT	2015/12/07 * 12
MAT-20	Attenuator(10dB)(above 1GHz)	HIROSE ELECTRIC CO.,LTD.	AT-110	-	AT	2016/01/08 * 12
MAT-10	Attenuator(10dB)	Weinschel Corp	2	BL1173	AT	2015/11/10 * 12
MSA-13	Spectrum Analyzer	Agilent	E4440A	MY46185823	AT	2016/06/17 * 12
MPM-09	Power Meter	Anritsu	ML2495A	6K00003348	AT	2015/10/19 * 12
MPSE-12	Power sensor	Anritsu	MA2411B	011598	AT	2015/10/19 * 12
MOS-24	Thermo-Hygrometer	Custom	CTH-201	0005	AT	2016/01/21 * 12

**The expiration date of the calibration is the end of the expired month.**

**All equipment is calibrated with valid calibrations. Each measurement data is traceable to the national or international standards.**

**As for some calibrations performed after the tested dates, those test equipment have been controlled by means of an unbroken chains of calibrations.**

**Test Item: RE: Radiated Emission test  
AT: Antenna Terminal Conducted test**

**UL Japan, Inc.**

**Ise EMC Lab.**

4383-326 Asama-cho, Ise-shi, Mie-ken 516-0021 JAPAN

Telephone : +81 596 24 8999

Facsimile : +81 596 24 8124