



FCC 47 CFR PART 15 SUBPART B

TEST REPORT

For

Applicant: RM Acquisition LLC

Address: 9855 Woods Dr., Skokie, IL. 60077

Product Name: Dash Cam

Model Number: Dash Cam 300

Brand Name: Rand McNally

FCC ID: A4C-CAM300

Report No.: MTE/HNZ/A15121687

Date of Issue: Dec. 30, 2015

Issued by: Most Technology Service Co., Ltd.

Address: No.5, Langshan 2nd Rd., North Hi-Tech Industrial park, Nanshan, Shenzhen, Guangdong, China

Tel: 86-755-86026850

Fax: 86-755-26013350

The report consists 22 pages in total. It may be duplicated completely for legal use with the approval of the applicant. It should not be reproduced except in full, without the written approval of our laboratory. The client should not use it to claim product endorsement by MOST. The test results in the report only apply to the tested sample. The test report shall be invalid without all the signatures of testing engineers, reviewer and approver.

TABLE OF CONTENTS

1. VERIFICATION OF CONFORMITY 3

2. GENERAL INFORMATION 4

2.1 PRODUCT INFORMATION 4

2.2 OBJECTIVE 5

2.3 TEST STANDARDS AND RESULTS 5

2.4 ENVIRONMENTAL CONDITIONS 5

2.5 MEASUREMENT UNCERTAINTY 5

3. TEST METHODOLOGY 6

3.1 TEST FACILITY 6

3.2 GENERAL TEST PROCEDURES 6

3.3 FCC PART 15.205 RESTRICTED BANDS OF OPERATIONS 7

4. SETUP OF EQUIPMENT UNDER TEST 8

4.1 SETUP CONFIGURATION OF EUT 8

4.2 EUT configuration 8

4.3 Block Diagram of connection between EUT and simulation 8

4.3 TEST EQUIPMENT LIST 9

5. 47 CFR PART 15B REQUIREMENTS 10

5.1 GENERAL INFORMATION 10

6. LINE CONDUCTED EMISSION TEST 11

6.1. LIMITS OF LINE CONDUCTED EMISSION TEST 11

6.2. BLOCK DIAGRAM OF TEST SETUP 11

6.3. Test procedure 12

6.4. Test Result 12

PASS 12

7. RADIATED EMISSION TEST 15

7.1. LIMITS OF RADIATED DISTURBANCES AT 3M DISTANCES FOR CLASS B 15

7.2 TEST DESCRIPTION 16

End of the report 19

1. VERIFICATION OF CONFORMITY

Equipment Under Test: Dash Cam

Brand Name: Rand McNally

Model Number: Dash Cam 300

Series Number: N/A

FCC ID: A4C-CAM300

Applicant: RM Acquisition LLC
9855 Woods Dr.,Skokie,IL.60077

Manufacturer: Shenzhen Samoon Technology Co., Ltd
Floor 9, Building 7,ZhongYunTai Industry Park, Yingrenshi Road Crossing,
Shiyan Town, Bao'an District ,Shenzhen ,China

Technical Standards: FCC Part 15 B

File Number: MTE/HNZ/A15121687

Date of test: Dec. 03-29, 2015

Deviation: None

Condition of Test Sample: Normal

The above equipment was tested by MOST for compliance with the requirements set forth in FCC Part 15 and the Technical Standards mentioned above. This said equipment in the configuration described in this report shows the maximum emission levels emanating from equipment and the level of the immunity endurance of the equipment are within the compliance requirements.

The test results of this report relate only to the tested sample identified in this report.

Tested by (+ signature): Helen
 Helen zhu Dec. 03-29, 2015

Review by (+ signature): Henry
 Henry Chen Dec. 30, 2015



Approved by (+ signature): [Signature]
 Yvette Zhou(Manager) Dec. 30, 2015

2. GENERAL INFORMATION

2.1 PRODUCT INFORMATION

Description:	Dash Cam
Model Name:	Dash Cam 300
Series Number:	N/A
Model Difference description:	N/A
Power Supply:	1、 DC 5V by car charging 2、 DC 3.7V by battery
Temperature Range:	-20°C ~ +50°C

NOTE:

1. For a more detailed features description about the EUT, please refer to User's Manual.

2.2 OBJECTIVE

Perform FCC Part 15 Subpart B tests for FCC Marking.

2.3 TEST STANDARDS AND RESULTS

Test items and the results are as bellow:

EMISSION			
Standard	Item	Result	Remarks
FCC15.207	Conducted	PASS	Meet Class B limit
FCC15.209	Radiated	PASS	Meet Class B limit

- Note:
1. The test result judgment is decided by the limit of measurement standard
 2. The information of measurement uncertainty is available upon the customer’s request.

2.4 ENVIRONMENTAL CONDITIONS

During the measurement the environmental conditions were within the listed ranges:

- Temperature: 15-35°C
- Humidity: 30-60 %
- Atmospheric pressure: 86-106 kPa

2.5 MEASUREMENT UNCERTAINTY

The uncertainty is calculated using the methods suggested in the “Guide to the Expression of Uncertainty in Measurement” (GUM) published by ISO.

The report uncertainty of measurement $y \pm U$, where expanded uncertainty U is based on a standard uncertainty multiplied by a coverage factor of $k=2$, Providing a level of confidence of approximately 95%

- Uncertainty of Conducted Emission, $U_c = \pm 1.8\text{dB}$
- Uncertainty of Radiated Emission, $U_c = \pm 3.2\text{dB}$

3. TEST METHODOLOGY

3.1 TEST FACILITY

Test Site:	Most Technology Service Co., Ltd.
Location:	No.5, Langshan 2nd Rd, North Hi-Tech Industrial park, Nanshan, Shenzhen, Guangdong, China
Description:	There is one 3m semi-anechoic an area test sites and two line conducted labs for final test. The Open Area Test Sites and the Line Conducted labs are constructed and calibrated to meet the FCC requirements in documents ANSI C63.4:2009 and CISPR 16 requirements. The FCC Registration Number is 490827 . The CNAS Registration Number is CNAS L3573 .
Site Filing:	The site description is on file with the Federal Communications Commission, 7435 Oakland Mills Road, Columbia, MD 21046.
Instrument Tolerance:	All measuring equipment is in accord with ANSI C63.4:2009 and CISPR 16 requirements that meet industry regulatory agency and accreditation agency requirement.
Ground Plane:	Two conductive reference ground planes were used during the Line Conducted Emission, one in vertical and the other in horizontal. The dimensions of these ground planes are as below. The vertical ground plane was placed distancing 40 cm to the rear of the wooden test table on where the EUT and the support equipment were placed during test. The horizontal ground plane projected 50 cm beyond the footprint of the EUT system and distanced 80 cm to the wooden test table. For Radiated Emission Test, one horizontal conductive ground plane extended at least 1m beyond the periphery of the EUT and the largest measuring antenna, and covered the entire area between the EUT and the antenna. It has no holes or gaps having longitudinal dimensions larger than one-tenth of a wavelength at the highest frequency of measurement up to 1GHz.

3.2 GENERAL TEST PROCEDURES

Conducted Emissions

The EUT is placed on the turntable, which is 0.8 m above ground plane. According to the requirements in Section 13.1.4.1 of ANSI C63.4:2009,Conducted emissions from the EUT measured in the frequency range between 0.15 MHz and 30MHz using CISPR Quasi-peak and average detector modes.

Radiated Emissions

The EUT is placed on a turn table, which is 0.8 m above ground plane. The turntable shall rotate 360 degrees to determine the position of maximum emission level. EUT is set 3m away from the receiving antenna, which varied from 1m to 4m to find out the highest emission. And also, each emission was to be maximized by changing the polarization of receiving antenna both horizontal and vertical. In order to find out the maximum emissions, exploratory radiated emission measurements were made according to the requirements in Section 13.1.4.1 of ANSI C63.4:2009.

3.3 FCC PART 15.205 RESTRICTED BANDS OF OPERATIONS

(a) Except as shown in paragraph (d) of this section, only spurious emissions are permitted in any of the frequency bands listed below:

MHz	MHz	MHz	GHz
0.090 - 0.110	16.42 - 16.423	399.9 - 410	4.5 - 5.15
¹ 0.495 - 0.505	16.69475 - 16.69525	608 - 614	5.35 - 5.46
2.1735 - 2.1905	16.80425 - 16.80475	960 - 1240	7.25 - 7.75
4.125 - 4.128	25.5 - 25.67	1300 - 1427	8.025 - 8.5
4.17725 - 4.17775	37.5 - 38.25	1435 - 1626.5	9.0 - 9.2
4.20725 - 4.20775	73 - 74.6	1645.5 - 1646.5	9.3 - 9.5
6.215 - 6.218	74.8 - 75.2	1660 - 1710	10.6 - 12.7
6.26775 - 6.26825	108 - 121.94	1718.8 - 1722.2	13.25 - 13.4
6.31175 - 6.31225	123 - 138	2200 - 2300	14.47 - 14.5
8.291 - 8.294	149.9 - 150.05	2310 - 2390	15.35 - 16.2
8.362 - 8.366	156.52475 - 156.52525	2483.5 - 2500	17.7 - 21.4
8.37625 - 8.38675	156.7 - 156.9	2655 - 2900	22.01 - 23.12
8.41425 - 8.41475	162.0125 - 167.17	3260 - 3267	23.6 - 24.0
12.29 - 12.293	167.72 - 173.2	3332 - 3339	31.2 - 31.8
12.51975 - 12.52025	240 - 285	3345.8 - 3358	36.43 - 36.5
12.57675 - 12.57725	322 - 335.4	3600 - 4400	(²)
13.36 - 13.41			

¹ Until February 1, 1999, this restricted band shall be 0.490-0.510 MHz.

² Above 38.6

(b) Except as provided in paragraphs (d) and (e), the field strength of emissions appearing within these frequency bands shall not exceed the limits shown in Section 15.209. At frequencies equal to or less than 1000 MHz, compliance with the limits in Section 15.209 shall be demonstrated using measurement instrumentation employing a CISPR quasi-peak detector. Above 1000 MHz, compliance with the emission limits in Section 15.209 shall be demonstrated based on the average value of the measured emissions. The provisions in Section 15.35 apply to these measurements.

4 SETUP OF EQUIPMENT UNDER TEST

4.1 SETUP CONFIGURATION OF EUT

See test photographs attached in Appendix 1 for the actual connections between EUT and support equipment.

4.2 EUT configuration

Interface cables:

Interface cable	Length [m]	Type	Line		Line termination
			shielded	unshielded	
Power cord	1.5	three wires	<input type="checkbox"/>	<input checked="" type="checkbox"/>	DC source
Power cord	1.5	three wires	<input type="checkbox"/>	<input checked="" type="checkbox"/>	PC
Power cord	1.5	three wires	<input type="checkbox"/>	<input checked="" type="checkbox"/>	Printer
VGA Cord	1.8	Video type	<input type="checkbox"/>	<input checked="" type="checkbox"/>	PC

Peripheral devices:

List out all peripheral not included with EuT used during the test

Kind of equipment	Manufacturer	Model no.
DC source	QJE	QJ6003S
Mouse	Lenovo	M-UAE96
Keyboard	HP	SK-2880
PC	Lenovo	SS05750640
Printer	Canon	L11121E
Monitor	PHILIPS	HEW8220Q

Remark:

All the equipment/cables were placed in the worst-case [-configuration to maximize the emission during the test.

Grounding was established in accordance with the manufacturer’s requirements and conditions for the intended use

4.3 Block Diagram of connection between EUT and simulation

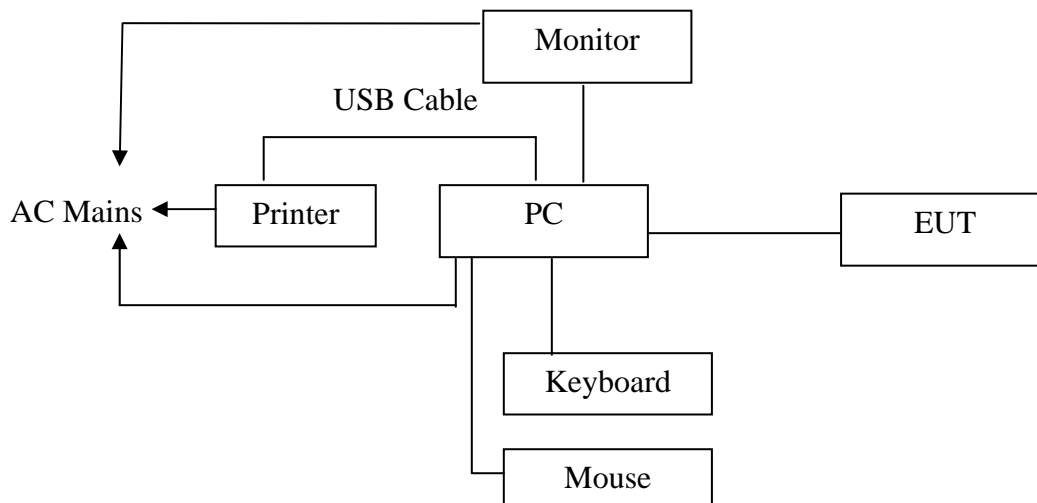

4. 3 TEST EQUIPMENT LIST

Instrumentation: The following list contains equipment used at MOST for testing. The equipment conforms to the CISPR 16-1 / ANSI C63.2 Specifications for Electromagnetic Interference and Field Strength Instrumentation from 10 kHz to 1.0 GHz or above.

No.	Equipment	Manufacturer	Model No.	S/N	Calibration due date
1	Test Receiver	Rohde & Schwarz	ESCI	100492	2015/03/31
2	L.I.S.N.	Rohde & Schwarz	ENV216	100093	2015/03/31
3	Coaxial Switch	Anritsu Corp	MP59B	6200283933	2015/03/31
4	Terminator	Hubersuhner	50Ω	No.1	2015/03/31
5	RF Cable	SchwarzBeck	N/A	No.1	2015/03/31
6	Test Receiver	Rohde & Schwarz	ESPI	101202	2015/03/31
7	Bilog Antenna	Sunol	JB3	A121206	2015/03/31
8	Test Antenna - Horn	SCHWARZBECK	BBHA9120D	756	2015/03/31
9	Test Antenna - Bi-Log	Schwarzbeck	VULB 9163	---	2015/03/31
10	Cable	Resenberger	N/A	NO.1	2015/03/31
11	Cable	SchwarzBeck	N/A	NO.2	2015/03/31
12	Cable	SchwarzBeck	N/A	NO.3	2015/03/31
13	DC Power Filter	DuoJi	DL2×30B	N/A	2015/03/31
14	Single Phase Power Line Filter	DuoJi	FNF 202B30	N/A	2015/03/31
15	3 Phase Power Line Filter	DuoJi	FNF 402B30	N/A	2015/03/31
16	Test Receiver	Rohde & Schwarz	ESCI	100492	2015/03/31
17	Absorbing Clamp	Luthi	MDS21	3635	2015/03/31
18	Coaxial Switch	Anritsu Corp	MP59B	6200283933	2015/03/31
19	AC Power Source	Kikusui	AC40MA	LM003232	2015/03/31
	DC Power Source	QJE	QJ6003S	---	2015/03/31
20	Test Analyzer	Kikusui	KHA1000	LM003720	2015/03/31
21	Line Impedance Network	Kikusui	LIN40MA-PCR-L	LM002352	2015/03/31
22	ESD Tester	Kikusui	KES4021	LM003537	2015/03/31
23	EMC PRO System	EM Test	UCS-500-M4	V0648102026	2015/03/31
24	Amplifier	A&R	150W1000	301584	2015/03/31
25	CDN	FCC	FCC-801-M2-25	47	2015/03/31
26	CDN	FCC	FCC-801-M3-25	107	2015/03/31
27	EM Injection Clamp	FCC	F-203I-23mm	403	2015/03/31
28	RF Cable	MIYAZAKI	N/A	No.1/No.2	2015/03/31
29	Universal Radio Communication Tester	ROHDE&SCHWARZ	CMU200	0304789	2015/03/31
30	Telecommunication Antenna	European Antennas	PSA 75301R/170	0304213	2015/03/31

NOTE: Equipments listed above have been calibrated and are in the period of validation.

5. 47 CFR PART 15B REQUIREMENTS

5.1 GENERAL INFORMATION

The field strength of radiation emission was measured in the following position: EUT stand-up position (Y axis), lie-down position (X, Z axis).

The following data show only with the worst case setup.

The worst case of X axis was reported.

Based on client request, all normal using modes of the normal function were tested but only the worst test data of the worst mode is reported by this report.

EUT Test Procedure:

1. Put EUT on the test table.
2. Power on the EUT.
3. Make sure the EUT operates normally during the test.

Mode 1: Running

During the measurement, A Communication link was established by EUT between two ports. The EUT was playing the data exchange function.

The EUT configuration of the emission test was **PC+ Mouse + Keyboard + Printer + Monitor + EUT.**

6. LINE CONDUCTED EMISSION TEST
6.1. LIMITS OF LINE CONDUCTED EMISSION TEST

Frequency	Maximum RF Line Voltage	
	Q.P.(dBuV)	Average(dBuV)
150kHz-500kHz	66-56	56-46
500kHz-5MHz	56	46
5MHz-30MHz	60	50

****Note:** 1. the lower limit shall apply at the transition frequency.
 2. The limit decreases linearly with the logarithm of the frequency in the range 0.15 MHz to 0.50 MHz

6.2. BLOCK DIAGRAM OF TEST SETUP

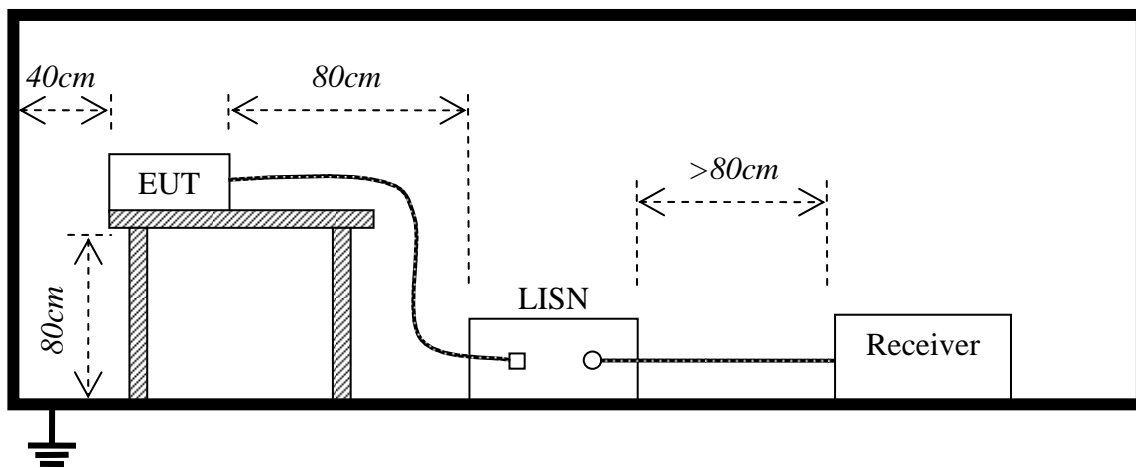

6.3. Test procedure

1. The E.U.T and simulators are connected to the main power through a line impedance stabilization network (L.I.S.N.). This provides a 50ohm/50uH coupling impedance for the measuring equipment.
2. Exploratory measurements were made to identify the frequency of the emission that has the highest amplitude relative to the limit;
3. The peripheral devices are also connected to the main power through a LISN that provides a 50ohm/50uH coupling impedance with 50ohm termination. (Please refer to the block diagram of the test setup and photographs).
4. Both sides of A.C. line are checked for maximum conducted interference. In order to find the maximum emission, the relative positions of equipment and all of the interface cables must be changed according to ANSI C63.10: 2013 on conducted measurement.
5. The bandwidth of test receiver (ESCI) set at 9 KHz.
6. All data was recorded in the Quasi-peak and average detection mode.

6.4. Test Result

PASS



Address: No.5, Langshan 2nd Rd., North Hi-Tech Industrial park
 Qianjiang, Chongqing, China
 Tel: 0755-86026850 Fax: 0755-26013350

Conducted Emission Measurement

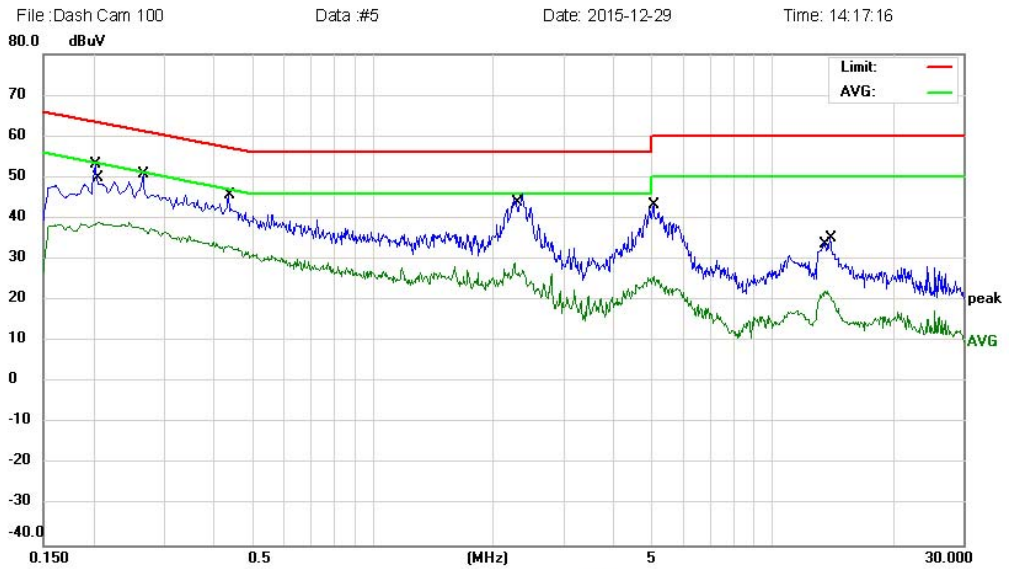

Site : site #1 Phase : **L1** Temperature: 23.4
 Limit: EN55022 Class B QP Power: DC 5V by USB Port Humidity: 52.7 %
 EUT: Dash Cam
 M/N: Dash Cam 300
 Mode: Date transmitting
 Note:

No.	Mk.	Freq. MHz	Reading Level dBuV	Correct Factor dB	Measure- ment dBuV	Limit dBuV	Over dB	Detector	Comment
1		0.2028	39.57	11.98	51.55	63.49	-11.94	QP	
2		0.2060	27.06	11.96	39.02	53.36	-14.34	AVG	
3	*	0.2660	39.10	11.56	50.66	61.24	-10.58	QP	
4		0.2660	25.96	11.56	37.52	51.24	-13.72	AVG	
5		0.4380	35.15	10.41	45.56	57.10	-11.54	QP	
6		0.4380	23.05	10.41	33.46	47.10	-13.64	AVG	
7		2.2780	17.70	9.28	26.98	46.00	-19.02	AVG	
8		2.2900	34.68	9.29	43.97	56.00	-12.03	QP	
9		5.0580	30.57	11.97	42.54	60.00	-17.46	QP	
10		5.0580	13.36	11.97	25.33	50.00	-24.67	AVG	
11		13.6020	24.60	9.00	33.60	60.00	-26.40	QP	
12		13.7340	13.28	9.00	22.28	50.00	-27.72	AVG	

*:Maximum data x:Over limit l:over margin

Engineer Signature: huzongyu



Address: No. 5, Langshan 2nd Rd., North Hi-Tech Industrial park
 (Lanshan Zhongmen)
 Tel: 0755-86026850 Fax: 0755-26013350

Conducted Emission Measurement

File: Dash Cam 100 Data #6 Date: 2015-12-29 Time: 14:25:41

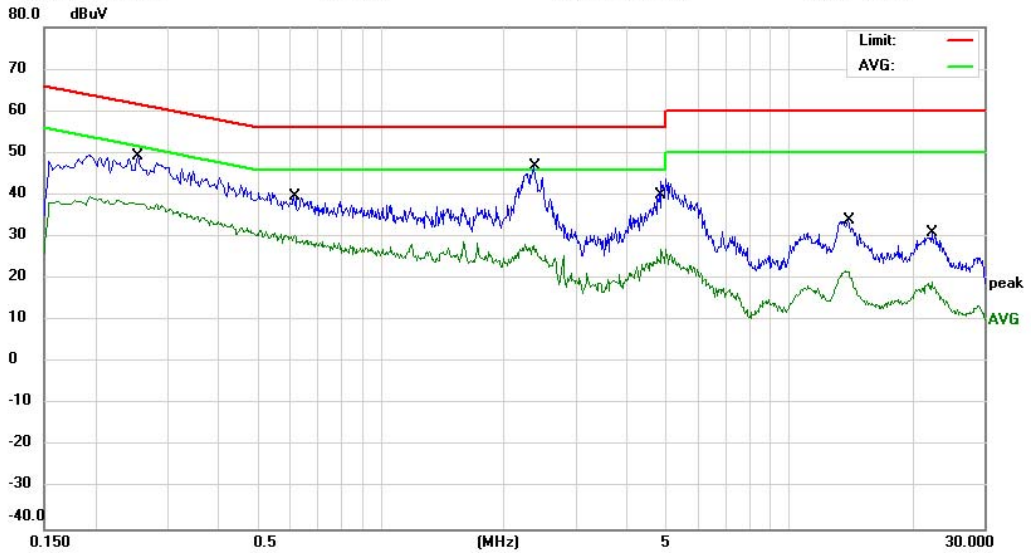

Site site #1 Phase: **N** Temperature: 23.4
 Limit: EN55022 Class B QP Power: DC 5V by USB Port Humidity: 52.7 %
 EUT: Dash Cam
 M/N: Dash Cam 300
 Mode: Data transmitting
 Note:

No.	Mk.	Freq.	Reading Level	Correct Factor	Measurement	Limit	Over	Detector	Comment
		MHz	dBuV	dB	dBuV	dBuV	dB		
1		0.2540	37.61	11.64	49.25	61.62	-12.37	QP	
2		0.2540	26.33	11.64	37.97	51.62	-13.65	AVG	
3		0.6140	29.77	10.00	39.77	56.00	-16.23	QP	
4		0.6180	20.23	10.00	30.23	46.00	-15.77	AVG	
5	*	2.3820	37.51	9.38	46.89	56.00	-9.11	QP	
6		2.3820	18.46	9.38	27.84	46.00	-18.16	AVG	
7		4.7900	28.26	11.79	40.05	56.00	-15.95	QP	
8		4.7900	13.41	11.79	25.20	46.00	-20.80	AVG	
9		13.7660	12.89	9.00	21.89	50.00	-28.11	AVG	
10		13.9500	25.03	9.00	34.03	60.00	-25.97	QP	
11		22.0180	20.80	9.00	29.80	60.00	-30.20	QP	
12		22.0180	9.89	9.00	18.89	50.00	-31.11	AVG	

*:Maximum data x:Over limit !:over margin

Engineer Signature: huzongyu

7. RADIATED EMISSION TEST

7.1. LIMITS OF RADIATED DISTURBANCES AT 3M DISTANCES FOR CLASS B

According to FCC section 15.209 (a), except as provided elsewhere in this subpart, the emissions from an intentional radiator shall not exceed the field strength levels specified in the following table:

Frequency (MHz)	Field Strength ($\mu\text{V}/\text{m}$)	Measurement Distance (m)
0.009 - 0.490	2400/F(kHz)	300
0.490 - 1.705	24000/F(kHz)	30
1.705 - 30.0	30	30
30 - 88	100	3
88 - 216	150	3
216 - 960	200	3
Above 960	500	3

As shown in FCC section 15.35(b), for frequencies above 1000MHz, the field strength limits are based on average detector. When average radiated emission measurements are specified in this part, including emission measurements below 1000MHz, there also is a limit on the radio frequency emissions, as measured using instrumentation with a peak detector function, corresponding to 20dB above the maximum permitted average limit for the frequency being investigated unless a different peak emission limit is otherwise specified in the rules.

7.2 TEST DESCRIPTION

1) For radiated emissions from 9kHz to 30MHz

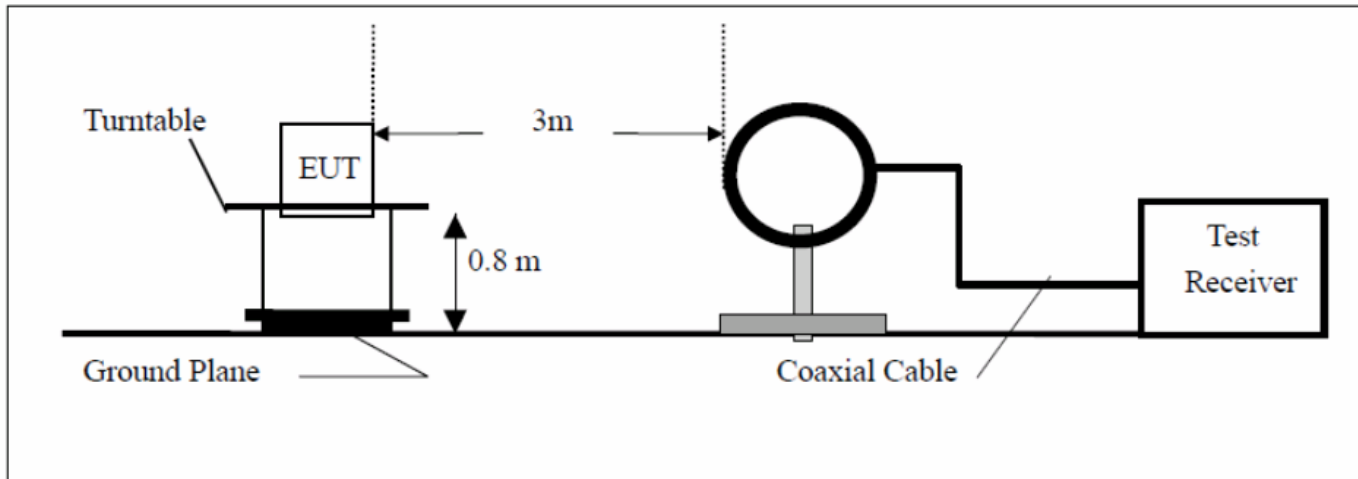

2) For radiated emissions from 30MHz to 1GHz

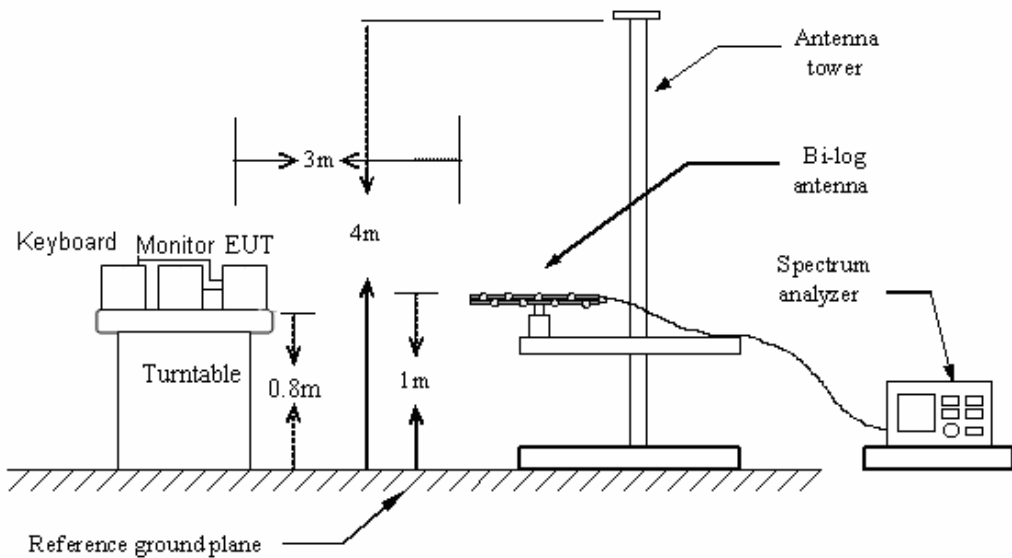

3) For radiated emissions above 1GHz

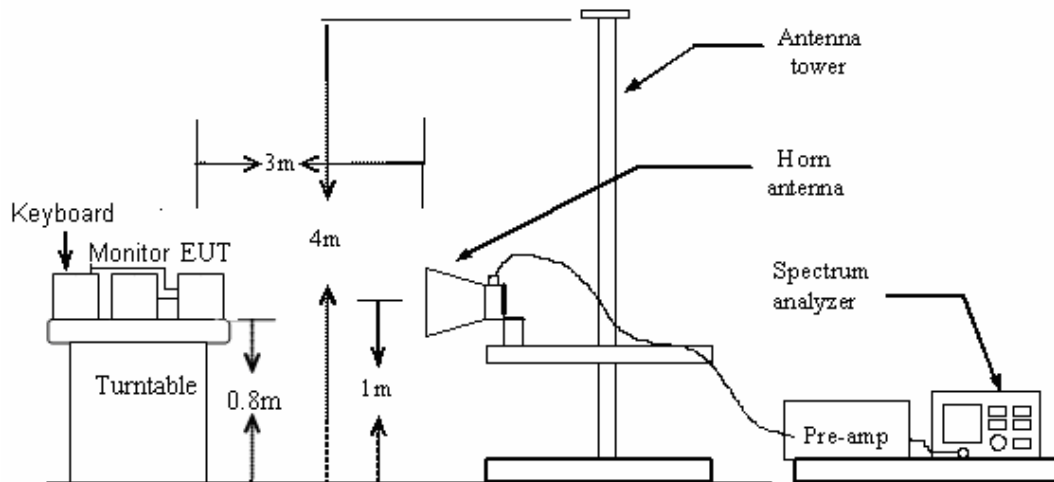
**7.3 Test Procedure:**

1. For frequencies above 1GHz, the frequencies of maximum emission was recorded by manually positioning the antenna close to the EUT and by moving the antenna over all sides of the EUT while observing a spectral display.
2. The EUT was placed on the top of a rotating table 0.8 meters above the ground at a 3 meter chamber. The table was rotated 360 degrees to determine the position of the highest radiation.
3. The EUT was set 3 meters away from the interference-receiving antenna, which was mounted on the top of a variable-height antenna tower.
4. The antenna height is varied from one meter to four meters above the ground to determine the maximum value of the field strength. Both horizontal and vertical polarizations of the antenna are set to make the measurement.
5. For each suspected emission, the EUT was arranged to its worst case and then the antenna was tuned to heights from 1 meter to 4 meters and the rote table was turned from 0 degrees to 360 degrees to find the maximum reading.

6. For frequencies above 1GHz, horn antenna mouth should face to the EUT all the time when rise or fall.

7. Set the spectrum analyzer in the following setting as:

Below 1GHz: PEAK: RBW=100 kHz / VBW=300 kHz / Sweep=AUTO QP: RBW=120 kHz / Sweep=AUTO

Above 1GHz: (a)PEAK: RBW=VBW=1MHz / Sweep=AUTO

(b)AVERAGE: RBW=1MHz / VBW=10Hz / Sweep=AUTO

The test-receiver system was set to Peak Detect Function and Specified Bandwidth with Maximum Hold Mode.

8. If the emission level of the EUT in peak mode was 10dB lower than the limit specified, then testing could be stopped and the peak values of the EUT would be reported. Otherwise the emissions that did not have 10dB margin would be re-tested one by one using peak, quasi-peak or average method as specified and then reported in a data sheet.

7.4 TEST RESULT

Preliminary Radiated Emission Test				
Frequency Range Investigated			30 MHz TO 1000 MHz	
Mode of operation	Date	Report No.	Data#	Worst Mode
Date transmitting	2015-12-28	MTE/HNZ/A15121687	Dash Cam 300_1_(H, V)	<input checked="" type="checkbox"/>

Note:

The test modes were carried out for all operation modes, The worst data was shown as the follow.

Below 1GHz



Address: No.5, Langshan 2nd Rd., North Hi-Tech Industrial park
 Changchun, Jilin
 Tel: 0755-86026850 Fax: 0755-26013350

Radiated Emission Measurement

File: Dash Cam 300 Data: #2 Date: 2015-12-28 Time: 09:43:42

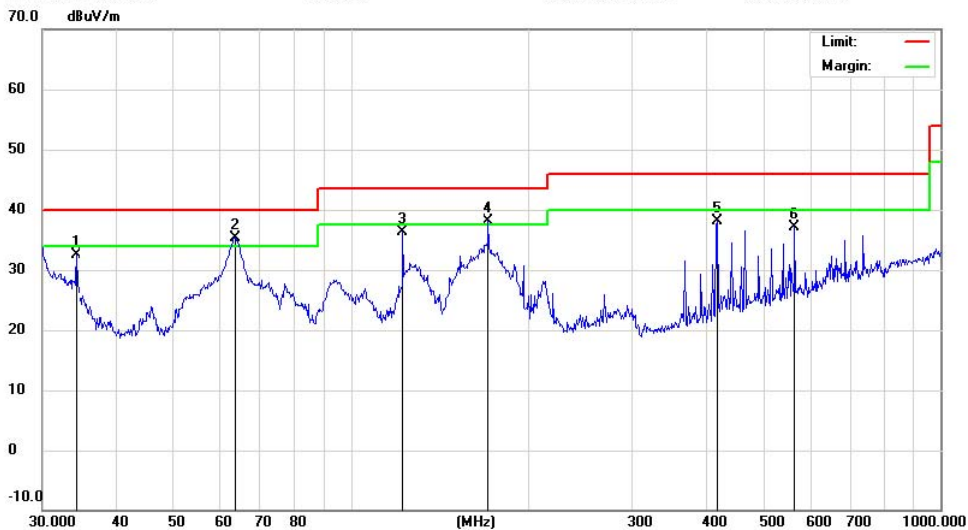

Site: site #1 Polarization: **Vertical** Temperature: 24
 Limit: FCC Part15 B 3M Radiation Power: DC 5V by Car charger Humidity: 50.5 %
 EUT: Dash Cam Distance: 3m
 M/N: Dash Cam 300
 Mode: Date transmitting
 Note:

No.	Mk.	Freq.	Reading Level	Correct Factor	Measurement	Limit	Over	Antenna Height	Table Degree	Comment
		MHz	dBuV	dB	dBuV/m	dBuV/m	dB	cm	degree	
1		34.2760	12.39	20.12	32.51	40.00	-7.49	QP		
2	*	63.7588	24.24	11.14	35.38	40.00	-4.62	QP		
3		122.4040	18.68	17.55	36.23	43.50	-7.27	QP		
4	!	171.3925	20.98	17.13	38.11	43.50	-5.39	QP		
5		417.6409	18.24	19.79	38.03	46.00	-7.97	QP		
6		564.6388	14.28	22.80	37.08	46.00	-8.92	QP		

*:Maximum data x:Over limit !:over margin

Engineer Signature: FLY



Address: No. 5, Langshan 2nd Rd., North Hi-Tech Industrial park
 Changsha, Hunan
 Tel: 0755-86026850 Fax: 0755-26013350

Radiated Emission Measurement

File: Dash Cam 300 Data: #3 Date: 2015-12-28 Time: 09:53:55

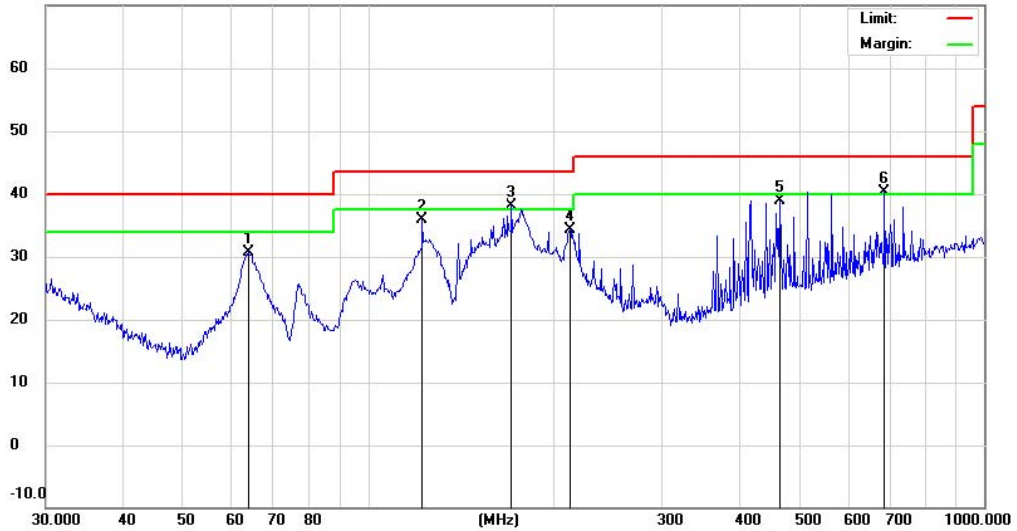

Site site #1 Polarization: **Horizontal** Temperature: 24
 Limit: FCC Part15 B 3M Radiation Power: DC 5V by Car charger Humidity: 50.5 %
 EUT: Dash Cam Distance: 3m
 M/N: Dash Cam 300
 Mode: Data transmitting
 Note:

No.	Mk.	Freq.	Reading Level	Correct Factor	Measurement	Limit	Over	Antenna Height	Table Degree	Detector	Comment
		MHz	dBuV	dB	dBuV/m	dBuV/m	dB	cm	degree		
1		63.9827	19.56	11.16	30.72	40.00	-9.28			QP	
2		122.4040	18.43	17.55	35.98	43.50	-7.52			QP	
3	*	171.3925	21.04	17.13	38.17	43.50	-5.33			QP	
4		213.0151	18.28	16.02	34.30	43.50	-9.20			QP	
5		465.5994	18.06	20.85	38.91	46.00	-7.09			QP	
6	l	687.1506	15.82	24.43	40.25	46.00	-5.75			QP	

*:Maximum data x:Over limit l:over margin

Engineer Signature: FLY

Above 1GHz:



Address: No. 5, Langshan 2nd Rd., North Hi-Tech Industrial park
 Changsha, Hunan
 Tel: 0755-86026850 Fax: 0755-26013350

Radiated Emission Measurement

File: Dash Cam 300 Data: #17 Date: 2015-12-26 Time: 9:40:44

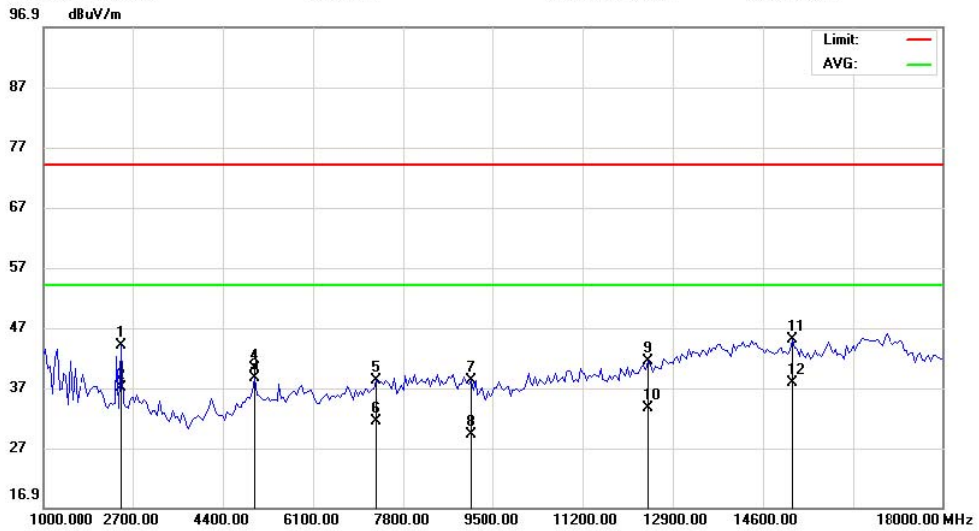

Site site #1 Polarization: **Vertical** Temperature: 24.0
 Limit: FCC 1000M-18000M PEAK Power: DC 5V by Car charger Humidity: 51.1 %
 EUT: Dash Cam Distance: 3m
 M/N: Dash Cam 300
 Mode: Date transmitting
 Note:

No.	Mk.	Freq. MHz	Reading Level dBuV	Correct Factor dB	Measure- ment dBuV/m	Limit dBuV/m	Over dB	Antenna Height cm	Table Degree degree	Detector	Comment
1		2487.500	52.25	-8.29	43.96	74.00	-30.04			peak	
2		2487.500	45.26	-8.29	36.97	54.00	-17.03			AVG	
3		4995.000	42.52	-3.85	38.67	74.00	-35.33			peak	
4	*	4995.000	44.06	-3.85	40.21	54.00	-13.79			AVG	
5		7290.000	41.27	-3.04	38.23	74.00	-35.77			peak	
6		7290.000	34.42	-3.04	31.38	54.00	-22.62			AVG	
7		9075.000	39.52	-1.26	38.26	74.00	-35.74			peak	
8		9075.000	30.51	-1.26	29.25	54.00	-24.75			AVG	
9		12432.50	40.50	0.96	41.46	74.00	-32.54			peak	
10		12432.50	32.71	0.96	33.67	54.00	-20.33			AVG	
11		15152.50	42.16	2.78	44.94	74.00	-29.06			peak	
12		15152.50	35.06	2.78	37.84	54.00	-16.16			AVG	

*:Maximum data x:Over limit !:over margin

Engineer Signature: sunny



Address: No.5, Langshan 2nd Rd., North Hi-Tech Industrial park
 Changchun, Jilin
 Tel: 0755-86026850 Fax: 0755-26013350

Radiated Emission Measurement

File: Dash Cam 300 Data: #18 Date: 2015-12-26 Time: 9:55:50

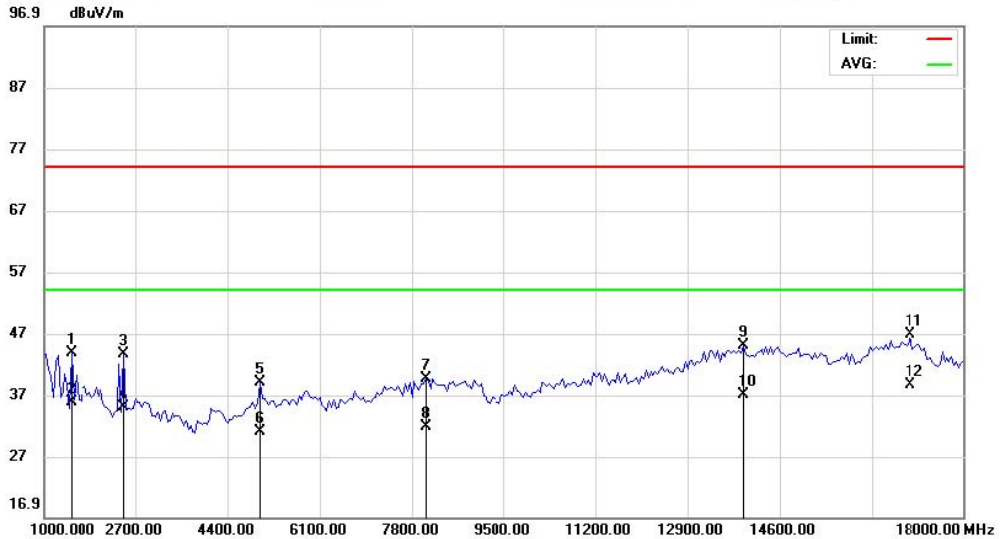

Site site #1 Polarization: **Vertical** Temperature: 24.0
 Limit: FCC 1000M-18000M PEAK Power: DC 5V by Car charger Humidity: 51.1 %
 EUT: Dash Cam Distance: 3m
 M/N: Dash Cam 300
 Mode: Data transmitting
 Note:

No.	Mk.	Freq. MHz	Reading Level dBuV	Correct Factor dB	Measure- ment dBuV/m	Limit dBuV/m	Over dB	Detector	Antenna Height cm	Table Degree degree	Comment
1		1510.000	52.25	-8.42	43.83	74.00	-30.17	peak			
2		1510.000	44.13	-8.42	35.71	54.00	-18.29	AVG			
3		2487.500	51.82	-8.29	43.53	74.00	-30.47	peak			
4		2487.500	43.25	-8.29	34.96	54.00	-19.04	AVG			
5		4995.000	42.82	-3.85	38.97	74.00	-35.03	peak			
6		4995.000	34.81	-3.85	30.96	54.00	-23.04	AVG			
7		8055.000	40.48	-0.97	39.51	74.00	-34.49	peak			
8		8055.000	32.71	-0.97	31.74	54.00	-22.26	AVG			
9		13920.000	41.56	3.46	45.02	74.00	-28.98	peak			
10		13920.000	33.63	3.46	37.09	54.00	-16.91	AVG			
11		17022.500	40.00	6.81	46.81	74.00	-27.19	peak			
12	*	17022.500	31.85	6.81	38.66	54.00	-15.34	AVG			

*:Maximum data x:Over limit !:over margin

Engineer Signature: sunny

End of the report