RADIO TEST REPORT

FCC 47 CFR PART 15 SUBPART C

INDUSTRY CANADA RSS-210

Test Standard	FCC Part 15.407 and RSS-247 Issue 2
FCC ID	A4C-1000DA
ISED No.	10199A-1000DA
Trade name	Rand McNally
Product name	OverDryve™ 8Pro
Model No.	OD8
Test Result	Pass

The test Result was tested by Compliance Certification Services Inc. The test data, data evaluation, test procedures, and equipment configurations shown in this report were given in ANSI C63.10: 2013 and compliance standards.

The test results of this report relate only to the tested sample (EUT) identified in this report.

The test Report of full or partial shall not copy. Without written approval of Compliance Certification Services Inc. (Hsinchu Lab)

The sample selected for test was production product and was provided by manufacturer.



Approved by:

Reviewed by:

Davis Tseng

Zeus Chen

Davis Tseng
Sr. Engineer

Zeus Chen
Supervisor

Revision History

Rev.	Issue Date	Revisions	Revised By
00	January 25, 2017	Initial Issue	Angel Cheng
01	March 27, 2017	1. Add Test Setup Photos in page 65, 66. 2. Revise section 3.3 in page 12. 3. Revise section 4.5.2 Duty Cycle in page 29.	Doris Chu
02	March 28, 2017	1. Modify Antenna Category & Antenna Type in page 5.	Angel Cheng
03	March 30, 2017	1. Remove remark in page 4. 2. Revise section 1.8 in page 8. 3. Revise section 2 in page 9. 4. Revise section 4.2.2 in page 16.	Angel Cheng
04	April 13, 2017	1. Update the test result sections in page 21, 23, 28.	Angel Cheng

Table of contents

1. GENERAL INFORMATION	4
1.1 EUT INFORMATION.....	4
1.2 EUT CHANNEL INFORMATION	5
1.3 ANTENNA INFORMATION	5
1.4 MEASUREMENT UNCERTAINTY.....	6
1.5 FACILITIES AND TEST LOCATION	7
1.6 INSTRUMENT CALIBRATION	7
1.7 SUPPORT AND EUT ACCESSORIES EQUIPMENT.....	8
1.8 TEST METHODOLOGY AND APPLIED STANDARDS	8
1.9 TABLE OF ACCREDITATIONS AND LISTINGS	8
2. TEST SUMMERY.....	9
3. DESCRIPTION OF TEST MODES.....	10
3.1 THE WORST MODE OF OPERATING CONDITION.....	10
3.2 THE WORST MODE OF MEASUREMENT	11
3.3 EUT DUTY CYCLE	12
4. TEST RESULT.....	13
4.1 AC POWER LINE CONDUCTED EMISSION	13
4.2 26DB BANDWIDTH AND OCCUPIED BANDWIDTH(99%).....	16
4.3 OUTPUT POWER MEASUREMENT	21
4.4 POWER SPECTRAL DENSITY	23
4.5 RADIATION BANEDGE AND SPURIOUS EMISSION	28
4.6 FREQUENCY STABILITY	62
APPENDIX 1 - PHOTOGRAPHS OF EUT	

1. GENERAL INFORMATION

1.1 EUT INFORMATION

Applicant	RM Acquisition, LLC 9855 Woods Drive Skokie, IL 60077 USA.																					
Equipment	OverDryve™ 8Pro																					
Model Name	OD8																					
Model Discrepancy	N/A																					
EUT Functions	IEEE 802.11 abgn+BT+GPS+FM																					
Received Date	Jan. 09, 2017																					
Date of Test	Jan 03, 2017 ~ Jan 18, 2017																					
Output Power(W)	<table border="1"> <thead> <tr> <th>Band</th> <th>Mode</th> <th>Frequency Range (MHz)</th> <th>Output Power (W)</th> <th>EIRP Output Power (W)</th> </tr> </thead> <tbody> <tr> <td rowspan="3">U-NII-1</td> <td>IEEE 802.11a</td> <td>5180 ~ 5240</td> <td>0.0240</td> <td>0.0292</td> </tr> <tr> <td>IEEE 802.11n HT 20 MHz</td> <td>5180 ~ 5240</td> <td>0.0175</td> <td>0.0214</td> </tr> <tr> <td>IEEE 802.11n HT 40 MHz</td> <td>5190 ~ 5230</td> <td>0.0171</td> <td>0.0208</td> </tr> </tbody> </table>				Band	Mode	Frequency Range (MHz)	Output Power (W)	EIRP Output Power (W)	U-NII-1	IEEE 802.11a	5180 ~ 5240	0.0240	0.0292	IEEE 802.11n HT 20 MHz	5180 ~ 5240	0.0175	0.0214	IEEE 802.11n HT 40 MHz	5190 ~ 5230	0.0171	0.0208
Band	Mode	Frequency Range (MHz)	Output Power (W)	EIRP Output Power (W)																		
U-NII-1	IEEE 802.11a	5180 ~ 5240	0.0240	0.0292																		
	IEEE 802.11n HT 20 MHz	5180 ~ 5240	0.0175	0.0214																		
	IEEE 802.11n HT 40 MHz	5190 ~ 5230	0.0171	0.0208																		
Power Operation	<input checked="" type="checkbox"/> Adapter Model: W12-010N3A I/P: 100-240V, 50/60Hz, 0.3A O/P: 5V, 2A <input checked="" type="checkbox"/> Host system <input checked="" type="checkbox"/> DC Type : <input checked="" type="checkbox"/> Battery <input checked="" type="checkbox"/> Car Charger <input type="checkbox"/> DC Power Supply																					

1.2 EUT CHANNEL INFORMATION

Frequency Range	IEEE 802.11a	5180 ~ 5240 MHz
	IEEE 802.11n HT 20 MHz	5180 ~ 5240 MHz
	IEEE 802.11n HT 40 MHz	5190 ~ 5230 MHz
Modulation Type	1. IEEE 802.11a mode: OFDM 2. IEEE 802.11n HT 20 MHz mode: OFDM 3. IEEE 802.11n HT 40 MHz mode: OFDM	

Remark:

Refer as ANSI 63.10:2013 clause 5.6.1 Table 4 for test channels

Number of frequencies to be tested		
Frequency range in which device operates	Number of frequencies	Location in frequency range of operation
<input type="checkbox"/> 1 MHz or less	1	Middle
<input type="checkbox"/> 1 MHz to 10 MHz	2	1 near top and 1 near bottom
<input checked="" type="checkbox"/> More than 10 MHz	3	1 near top, 1 near middle, and 1 near bottom

1.3 ANTENNA INFORMATION

Antenna Category	<input type="checkbox"/> Integral: antenna permanently attached <input type="checkbox"/> External dedicated antennas <input checked="" type="checkbox"/> External Unique antenna connector
Antenna Type	<input type="checkbox"/> PIFA <input checked="" type="checkbox"/> PCB <input type="checkbox"/> Dipole <input type="checkbox"/> Coils
Antenna Gain	0.86 dBi

1.4 MEASUREMENT UNCERTAINTY

PARAMETER	UNCERTAINTY
AC Powerline Conducted Emission	+/- 1.2575
Emission bandwidth, 20dB bandwidth	+/- 1.4003
RF output power, conducted	+/- 1.1372
Power density, conducted	+/- 1.4003
3M Semi Anechoic Chamber / 30M~200M	+/- 4.0138
3M Semi Anechoic Chamber / 200M~1000M	+/- 3.9483
3M Semi Anechoic Chamber / 1G~8G	+/- 2.5975
3M Semi Anechoic Chamber / 8G~18G	+/- 2.6112
3M Semi Anechoic Chamber / 18G~26G	+/- 2.7389
3M Semi Anechoic Chamber / 26G~40G	+/- 2.9683
3M Semi Anechoic Chamber / 40G~60G	+/- 1.8509
3M Semi Anechoic Chamber / 60G~75G	+/- 1.9869
3M Semi Anechoic Chamber / 75G~110G	+/- 2.9651
3M Semi Anechoic Chamber / 110G~170G	+/- 2.7807
3M Semi Anechoic Chamber / 170G~220G	+/- 3.6437
3M Semi Anechoic Chamber / 220G~325G	+/- 4.2982

Remark:

1. This uncertainty represents an expanded uncertainty expressed at approximately the 95% confidence level using a coverage factor of $k=2$
2. ISO/IEC 17025 requires that an estimate of the measurement uncertainties associated with the emissions test results be included in the report.

1.5 FACILITIES AND TEST LOCATION

All measurement facilities used to collect the measurement data are located at No.989-1, Wenshan Rd., Shangshan Village Qionglin Township, Hsinchu County 30741, Taiwan (R.O.C.)

Test site	Test Engineer	Remark
AC Conduction Room	Jim Lian	
Radiation	Ed Chiang	
RF Conducted	Eric Lee	

Remark: The sites are constructed in conformance with the requirements of ANSI C63.7, ANSI C63.4 and CISPR Publication 22.

1.6 INSTRUMENT CALIBRATION

RF Conducted Test Site					
Equipment	Manufacturer	Model	S/N	Cal Date	Cal Due
Spectrum Analyzer	R&S	FSV 40	101073	08/01/2017	07/31/2017

3M 966 Chamber Test Site					
Equipment	Manufacturer	Model	S/N	Cal Due	Cal Due
Bi-log Antenna	TESEQ	CBL 6112D	35403	07/03/2016	07/02/2017
Double Ridged BroadBand Horn Antenna	SCHWARZBECK	BBHA 9120 D	9120D-778	07/15/2016	07/14/2017
Double Ridged Guide Horn Antenna	ETS · LINDGREN	3117	00078733	11/17/2016	11/16/2017
EMI Test Receiver	ROHDE & SCHWARZ	ESCI	100221	04/27/2016	04/26/2017
Horn Antenna	COM-POWER	AH-840	03077	12/02/2016	12/01/2017
Loop Antenna	COM-POWER	AL-130	121060	05/24/2016	05/23/2017
Preamplifier	Agilent	8447D	2944A10052	07/13/2016	07/12/2017
Preamplifier	Agilent	8449B	3008A01916	07/13/2016	07/12/2017
PSA Series Spectrum Analyzer	Agilent	E4446A	MY46180323	04/13/2016	04/12/2017
Software	E3.815206a				

AC Conducted Emissions Test Site					
Equipment	Manufacturer	Model	S/N	Cal Date	Cal Due
EMI Test Receiver	R&S	ESCI	101201	08/20/2016	08/19/2017
LISN	Schwarzbeck	NNLK 8129	8129-286	08/19/2016	08/18/2017
LISN(EUT)	Schwarzbeck	NSLK 8127	8127-527	08/19/2016	08/18/2017
Pulse Limiter	R&S	ESH3Z2	C3010026-2	08/21/2016	08/22/2017
Software	EZ-EMC				

Remark: Each piece of equipment is scheduled for calibration once a year.

1.7 SUPPORT AND EUT ACCESSORIES EQUIPMENT



EUT Accessories Equipment					
No.	Equipment	Brand	Model	Series No.	FCC ID
	N/A				

Support Equipment					
No.	Equipment	Brand	Model	Series No.	FCC ID
1	Earphone	INTOPIC	JASS-288	N/A	N/A
2	Monitor	ASUS	PA248Q	G5LMQS071275	N/A

1.8 TEST METHODOLOGY AND APPLIED STANDARDS

The test methodology, setups and results comply with all requirements in accordance with ANSI C63.10:2013, FCC Part 2, FCC Part 15.407, KDB 789033 D02 v01r03.

1.9 TABLE OF ACCREDITATIONS AND LISTINGS

Country	Agency	Scope of Accreditation	Logo
USA	FCC	3M Semi Anechoic Chamber (FCC MRA: TW1027) to perform FCC Part 15 measurements	
Canada	Industry Canada	3M Semi Anechoic Chamber (IC 2324G-1 / IC 2324G-2) to perform	

2. TEST SUMMERY

FCC Standard Section	IC Standard Section	Chapter	Test Item	Result
15.203	-	1.2	Antenna Requirement	Pass
15.207	RSS-Gen(8.8)	4.1	AC Conducted Emission	Pass
15.403(i)	-	4.2	26dB Bandwidth	Pass
15.403(i)	RSS-247(6.2.4)	4.2	6dB Bandwidth	N/A
15.403(i)	RSS-Gen 6.6	4.2	Occupied Bandwidth (99%)	Pass
15.407(a)	RSS-247 6.2.1.1	4.3	Output Power Measurement	Pass
15.407(a)	RSS-247 6.2.1.1	4.4	Power Spectral Density	Pass
15.407(b)	RSS-247 6.2.1.2	4.5	Radiation Band Edge	Pass
15.407(b)	RSS-247 6.2.1.2	4.5	Radiation Spurious Emission	Pass
15.407(g)	RSS-Gen 6.11	4.6	Frequency Stability	Pass

3. DESCRIPTION OF TEST MODES

3.1 THE WORST MODE OF OPERATING CONDITION

Operation mode	<ol style="list-style-type: none"> 1. IEEE 802.11a mode: 6Mbps 2. IEEE 802.11n HT 20 MHz mode: MCS0 3. IEEE 802.11n HT 40 MHz mode: MCS0 														
Operating Frequency Range & Number of Channels	<table border="1" data-bbox="572 728 1442 875"> <thead> <tr> <th></th> <th>Mode</th> <th>Frequency Range (MHz)</th> <th>Number of Channels</th> </tr> </thead> <tbody> <tr> <td rowspan="3">U-NII-1</td> <td>IEEE 802.11a</td> <td>5180 ~ 5240</td> <td>4 Channels</td> </tr> <tr> <td>IEEE 802.11n HT 20 MHz</td> <td>5180 ~ 5240</td> <td>4 Channels</td> </tr> <tr> <td>IEEE 802.11n HT 40 MHz</td> <td>5190 ~ 5230</td> <td>2 Channels</td> </tr> </tbody> </table>		Mode	Frequency Range (MHz)	Number of Channels	U-NII-1	IEEE 802.11a	5180 ~ 5240	4 Channels	IEEE 802.11n HT 20 MHz	5180 ~ 5240	4 Channels	IEEE 802.11n HT 40 MHz	5190 ~ 5230	2 Channels
	Mode	Frequency Range (MHz)	Number of Channels												
U-NII-1	IEEE 802.11a	5180 ~ 5240	4 Channels												
	IEEE 802.11n HT 20 MHz	5180 ~ 5240	4 Channels												
	IEEE 802.11n HT 40 MHz	5190 ~ 5230	2 Channels												

Remark:

1. EUT pre-scanned data rate of output power for each mode, the worst data rate were recorded in this report.

3.2 THE WORST MODE OF MEASUREMENT

AC Power Line Conducted Emission	
Test Condition	AC Power line conducted emission for line and neutral
Voltage/Hz	120V/60Hz
Test Mode	Mode 1:EUT power by host system via USB Cable
Worst Mode	<input checked="" type="checkbox"/> Mode 1 <input type="checkbox"/> Mode 2 <input type="checkbox"/> Mode 3 <input type="checkbox"/> Mode 4

Radiated Emission Measurement Above 1G	
Test Condition	Band edge, Emission for Unwanted and Fundamental
Voltage/Hz	120V/60Hz
Test Mode	Mode 1:EUT power by Battery
Worst Mode	<input checked="" type="checkbox"/> Mode 1 <input type="checkbox"/> Mode 2 <input type="checkbox"/> Mode 3 <input type="checkbox"/> Mode 4
Worst Position	<input type="checkbox"/> Placed in fixed position. <input checked="" type="checkbox"/> Placed in fixed position at X-Plane (E2-Plane) <input type="checkbox"/> Placed in fixed position at Y-Plane (E1-Plane) <input type="checkbox"/> Placed in fixed position at Z-Plane (H-Plane)
Worst Polarity	<input type="checkbox"/> Horizontal <input checked="" type="checkbox"/> Vertical

Radiated Emission Measurement Below 1G	
Test Condition	Radiated Emission Below 1G
Voltage/Hz	120V/60Hz
Test Mode	Mode 1:EUT power by Battery
Worst Mode	<input checked="" type="checkbox"/> Mode 1 <input type="checkbox"/> Mode 2 <input type="checkbox"/> Mode 3 <input type="checkbox"/> Mode 4

Remark:

1. The worst mode was record in this test report.
2. EUT pre-scanned in three axis ,X , Y, Z and two polarity, Horizontal and Vertical for radiated measurement. The worst case(X-Plane and Vertical) were recorded in this report.
3. For below 1G AC power line conducted emission and radiation emission were performed the EUT transmit at the Maximum bandwidth and Middle channel as worse case.
4. EUT Transmit only can by Battery to set. Therefore EUT used Battery mode for Radiated measurement above 1G and Conduction below 1G in test report.

3.3 EUT DUTY CYCLE

Duty Cycle				
Configuration	TX ON (ms)	TX ALL (ms)	Duty Cycle (%)	Duty Factor(dB)
802.11a	1.4203	1.4348	98.99	0.04
802.11n HT20	1.4203	1.4348	99.00	0.04
802.11n HT40	0.6667	0.6812	97.90	0.09

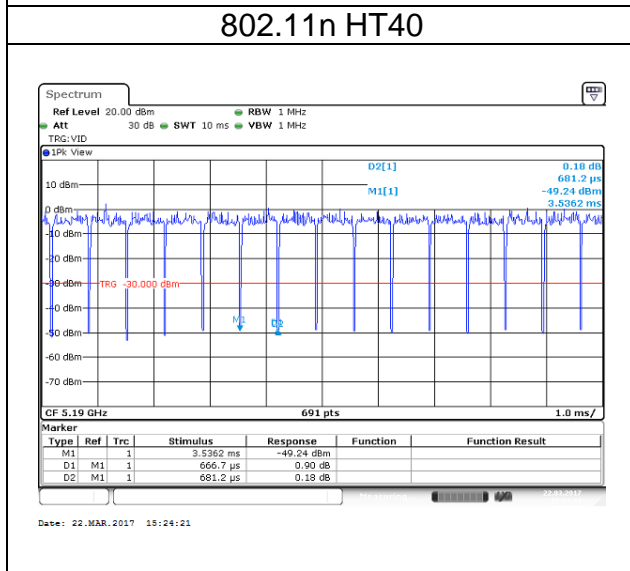
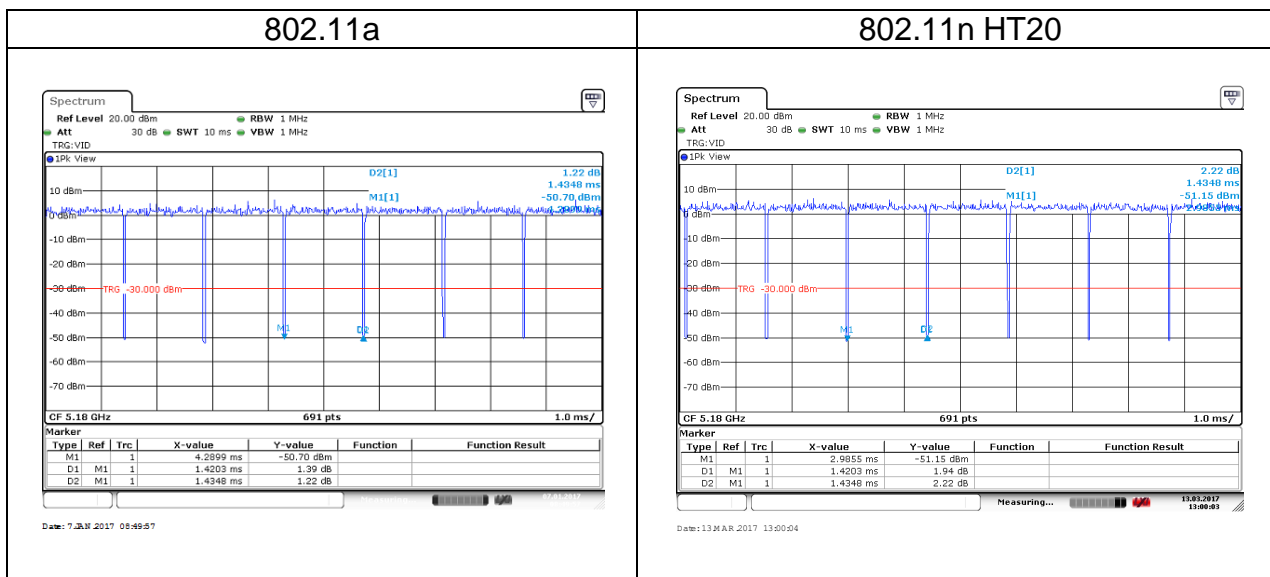

4. TEST RESULT

4.1 AC POWER LINE CONDUCTED EMISSION

4.1.1 Test Limit

According to §15.207(a) and RSS-GEN section 8.8,

Frequency Range (MHz)	Limits(dBμV)	
	Quasi-peak	Average
0.15 to 0.50	66 to 56*	56 to 46*
0.50 to 5	56	46
5 to 30	60	50

* Decreases with the logarithm of the frequency.

4.1.2 Test Procedure

Test method Refer as ANSI 63.10:2013 clause 6.2,

1. The EUT was placed on a non-conducted table, which is 0.8m above horizontal ground plane and 0.4m above vertical ground plane.
2. EUT connected to the line impedance stabilization network (LISN)
3. Receiver set RBW of 9kHz and Detector Peak, and note as quasi-peak and average.
4. Maximum procedure was performed on the six highest emissions to ensure EUT compliance.
5. Recorded Line for Neutral and Line.

4.1.3 Test Setup

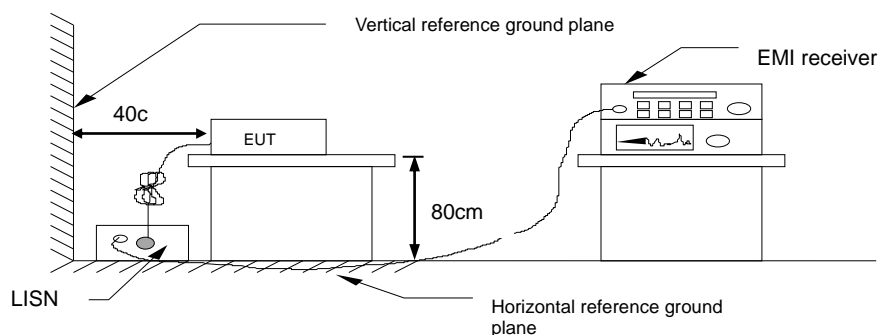

4.1.4 Test Result

Pass.

Test Data

Test Mode:	Mode 1	Temp/Hum	27(°C)/ 53%RH
Test Voltage:	120Vac / 60Hz	Test Date	Jan 03, 2017
Phase:	Line	Test Engineer	Jim Lian

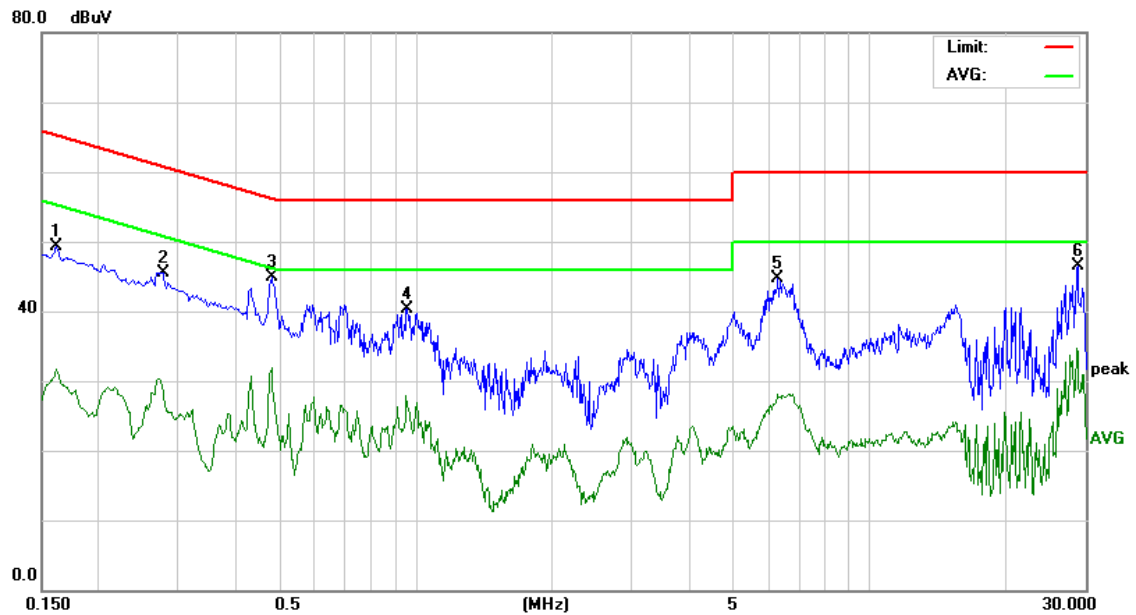

Frequency (MHz)	Reading (dBuV)	Factor (dB)	Result (dB)	Limit (dBuV)	Margin (dBuV)	Detector (dBuV)
0.16	39.26	9.97	49.23	65.36	-16.13	Peak
0.28	35.49	10.02	45.51	60.88	-15.37	Peak
0.48	34.90	10.03	44.93	56.30	-11.37	Peak
0.96	30.20	10.06	40.26	56.00	-15.74	Peak
6.29	34.40	10.32	44.72	60.00	-15.28	Peak
28.76	35.67	10.87	46.54	60.00	-13.46	Peak

Test Mode:	Mode 1	Temp/Hum	27(°C)/ 53%RH
Test Voltage:	120Vac / 60Hz	Test Date	Jan 03, 2017
Phase:	Neutral	Test Engineer	Jim Lian

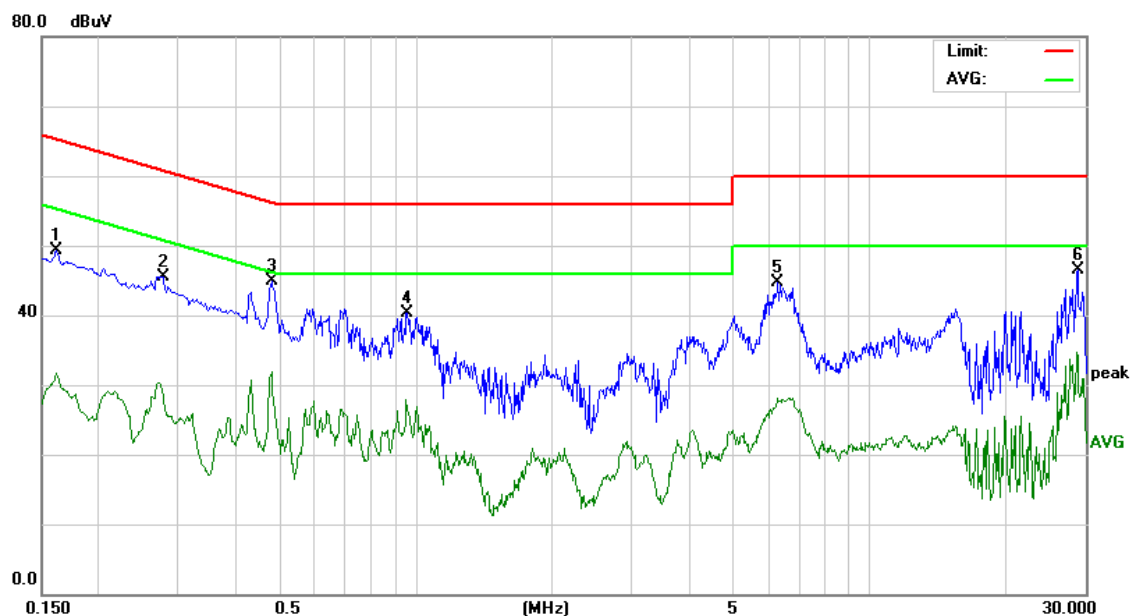

Frequency (MHz)	Reading (dBuV)	Factor (dB)	Result (dB)	Limit (dBuV)	Margin (dBuV)	Detector (dBuV)
0.16	44.85	9.92	54.77	65.36	-10.59	Peak
0.21	41.87	9.99	51.86	63.04	-11.18	Peak
0.27	40.76	9.99	50.75	61.24	-10.49	Peak
0.43	37.89	9.98	47.87	57.18	-9.31	Peak
0.43	30.18	9.98	40.16	47.18	-7.02	AVG
0.48	41.20	10.00	51.20	56.30	-5.10	Peak
0.48	33.00	10.00	43.00	46.30	-3.30	AVG
0.59	37.56	10.01	47.57	56.00	-8.43	Peak
0.60	26.96	10.01	36.97	46.00	-9.03	AVG

4.2 26DB BANDWIDTH AND OCCUPIED BANDWIDTH(99%)

4.2.1 Test Limit

26 dB Bandwidth : For reporting purposes only.

Occupied Bandwidth(99%) : For reporting purposes only.

4.2.2 Test Procedure

Test method Refer as KDB 789033 D02 v01r03 Section C, D, and ANSI 63.10:2013 clause 12.4.1&12.4.2.

1. The EUT RF output connected to the spectrum analyzer by RF cable.
2. Setting maximum power transmit of EUT
3. UNII-1, SA set RBW = 300kHz, VBW = 1MHz and Detector = Peak, to measurement 26 dB Bandwidth and 99% Bandwidth
4. UNII-3, SA set RBW = 100kHz, VBW = 300kHz and Detector = Peak, to measurement 26 dB Bandwidth and 99% Bandwidth
5. Measure and record the result of 26 dB Bandwidth and 99% Bandwidth. in the test report.

4.2.3 Test Setup

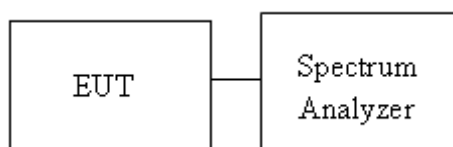

4.2.4 Test Result

UNII-1 5150-5250 MHz			
Test mode: IEEE 802.11a mode			
Channel	Frequency (MHz)	OBW(99%) (MHz)	26dB BW (MHz)
Low	5180	17.0043	28.4783
Mid	5220	16.9319	28.4783
High	5240	16.8596	28.2609
Test mode: IEEE 802.11n HT20 mode			
Channel	Frequency (MHz)	OBW(99%) (MHz)	26dB BW (MHz)
Low	5180	17.7279	26.5217
Mid	5220	17.6555	25.5072
High	5240	17.6555	25.5072
Test mode: IEEE 802.11n HT40 mode			
Channel	Frequency (MHz)	OBW(99%) (MHz)	26dB BW (MHz)
Low	5190	39.9421	76.2720
High	5230	38.7264	80.6700

Test Data

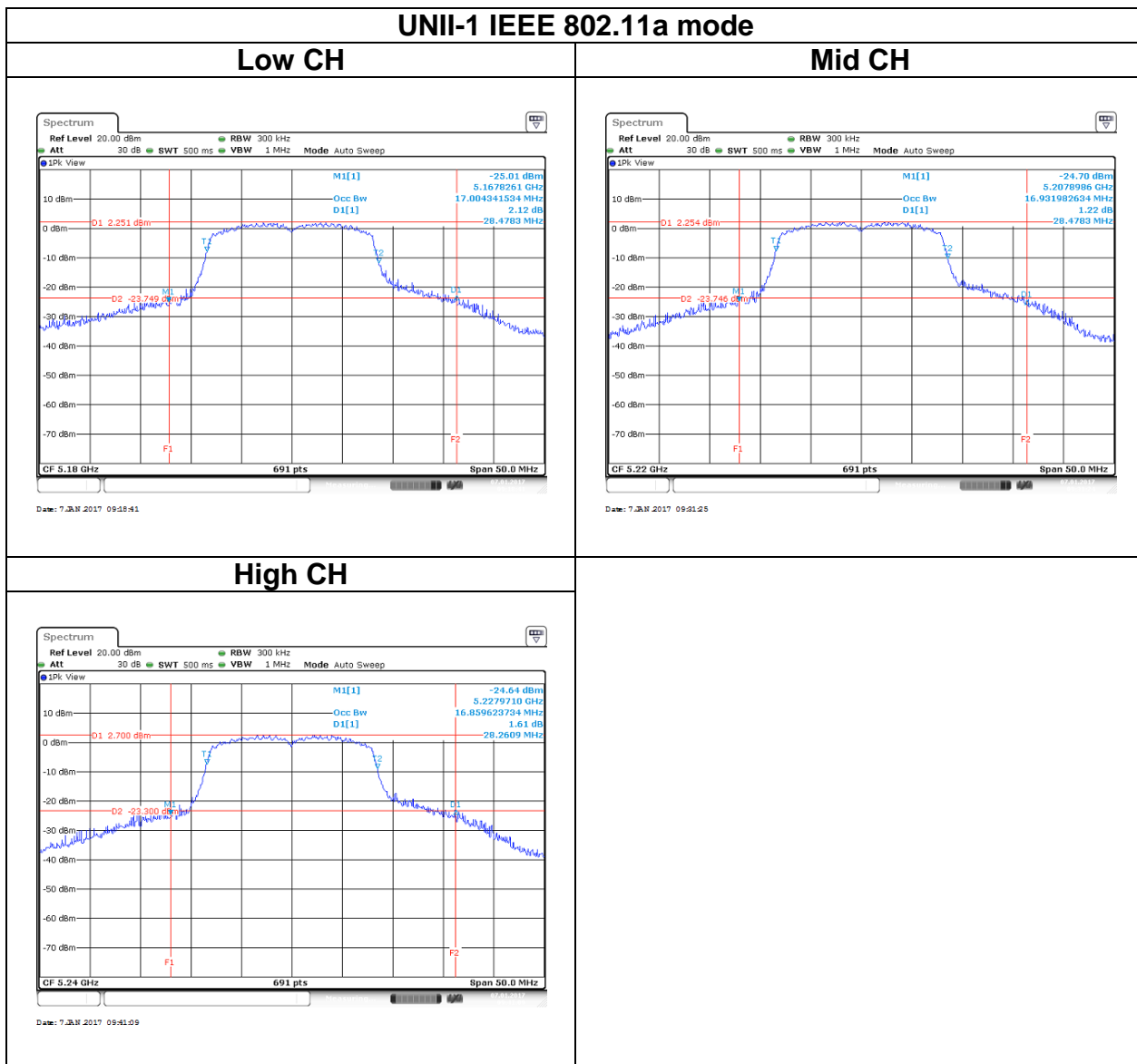

UNII-1 IEEE 802.11n HT20 mode

Low CH

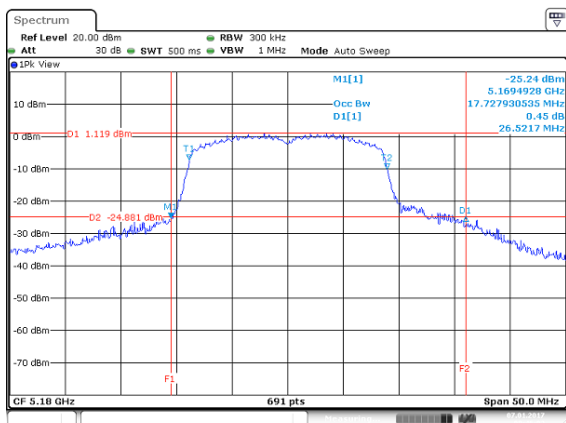

Mid CH

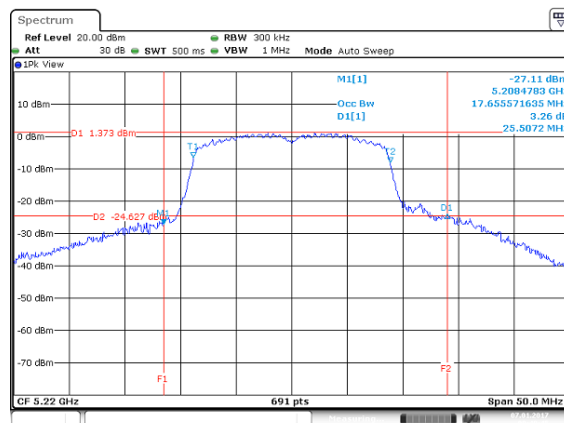

High CH

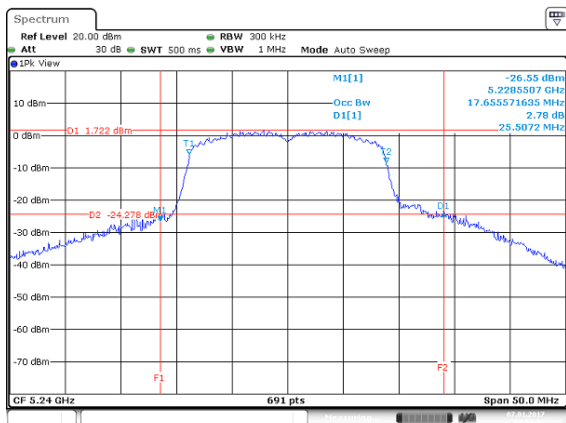

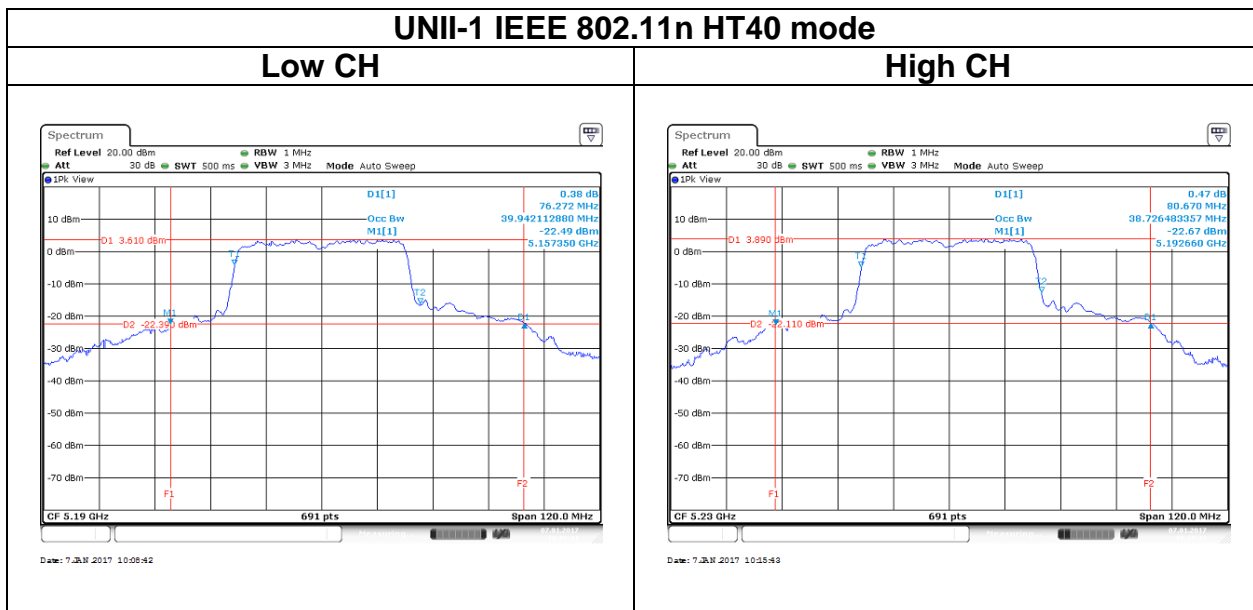

4.3 OUTPUT POWER MEASUREMENT

4.3.1 Test Limit

According to §15.407 (a)(1) and RSS-247 section 6.2.1.1.

UNII-1 :

For client devices in the 5.15-5.25 GHz band, the maximum conducted output power over the frequency band of operation shall not exceed 250 mW(24 dBm) and The maximum e.i.r.p. shall not exceed 200 mW or $10 + 10 \log_{10} B$, dBm, whichever power is less. B is the 99% emission bandwidth in megahertz ,provided the maximum antenna gain does not exceed 6 dBi. In addition, the maximum power spectral density shall not exceed 11 dBm in any 1 megahertz band. If transmitting antennas of directional gain greater than 6 dBi are used, both the maximum conducted output power and the maximum power spectral density shall be reduced by the amount in dB that the directional gain of the antenna exceeds 6 dBi.

UNII-1 Limit	<input checked="" type="checkbox"/> Antenna not exceed 6 dBi : 24dBm (EIRP : 23dBm) <input type="checkbox"/> Antenna with DG greater than 6 dBi : [Limit = 30 – (DG – 6)]
--------------	---

4.3.2 Test Procedure

Test method Refer as KDB 789033 D02 v01r02, Section E.3.b.

1. The EUT RF output connected to the power meter by RF cable.
2. Setting maximum power transmit of EUT.
3. The path loss was compensated to the results for each measurement.
4. Measure and record the result of Average output power. in the test report.

4.3.3 Test Setup

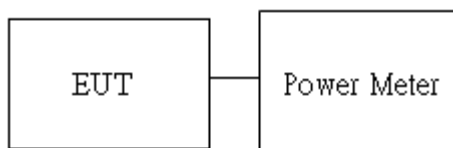

4.3.4 Test Result

Conducted output power :

UNII-1								
Config	CH	Freq. (MHz)	AV Power (dBm)	ERP AV Power (dBm)	AV Power (W)	ERP AV Power (W)	Limit (dBm)	ERP Limit (dBm)
IEEE 802.11a Data rate: 6Mbps	36	5180	12.88	13.74	0.0194	0.0237	24	23
	44	5220	13.54	14.40	0.0226	0.0276		
	48	5240	13.79	14.65	0.0240	0.0292		
IEEE 802.11n HT20 Data rate: MCS0	36	5180	11.65	12.51	0.0146	0.0178		
	44	5220	12.13	12.99	0.0163	0.0199		
	48	5240	12.44	13.30	0.0175	0.0214		
IEEE 802.11n HT40 Data rate: MCS0	38	5190	11.72	12.58	0.0149	0.0181		
	46	5230	12.33	13.19	0.0171	0.0208		

4.4 POWER SPECTRAL DENSITY

4.4.1 Test Limit

According to §15.407 (a)(1) and RSS-247 section 6.2.1.1

UNII-1 :

FCC: The maximum power spectral density shall not exceed 11 dBm in any 1 megahertz band.

IC: The e.i.r.p. spectral density shall not exceed 10 dBm in any 1.0 MHz band.

If transmitting antennas of directional gain greater than 6 dBi are used, both the maximum conducted output power and the maximum power spectral density shall be reduced by the amount in dB that the directional gain of the antenna exceeds 6 dBi.

UNII-1 Limit	<input type="checkbox"/> Antenna not exceed 6 dBi : 11 dBm (EIRP : 10 dBm) <input checked="" type="checkbox"/> Antenna with DG greater than 6 dBi : [Limit = 17 – (DG – 6),]
--------------	--

4.4.2 Test Procedure

Test method Refer as KDB 789033 D02 v01r03, Section F

1. The EUT RF output connected to the spectrum analyzer by RF cable.
2. Setting maximum power transmit of EUT
3. UNII-1, SA set RBW = 1MHz, VBW = 3MHz and Detector = RMS, to measurement Power Density.
4. The path loss and Duty Factor were compensated to the results for each measurement by SA.
5. Mark the maximum level.
6. Measure and record the result of power spectral density. in the test report.

4.4.3 Test Setup

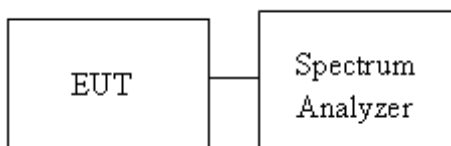

4.4.4 Test Result

UNII-1 5150-5250 MHz					
Test mode: IEEE 802.11a mode					
Channel	Frequency (MHz)	PPSD (dBm)	EIRP PSD (dBm)	Limit (dBm)	EIRP Limit (dBm)
Low	5180	0.21	1.07	11	10
Mid	5220	0.55	1.41		
High	5240	0.64	1.50		
Test mode: IEEE 802.11n HT20 mode					
Channel	Frequency (MHz)	PPSD (dBm)	EIRP PSD (dBm)	Limit (dBm)	EIRP Limit (dBm)
Low	5180	-1.22	-0.36	11	10
Mid	5220	-0.97	-0.11		
High	5240	-0.84	0.02		
Test mode: IEEE 802.11n HT40 mode					
Channel	Frequency (MHz)	PPSD (dBm)	EIRP PSD (dBm)	Limit (dBm)	EIRP Limit (dBm)
Low	5190	-4.61	-3.75	11	10
High	5230	-4.36	-3.50		

Test Data

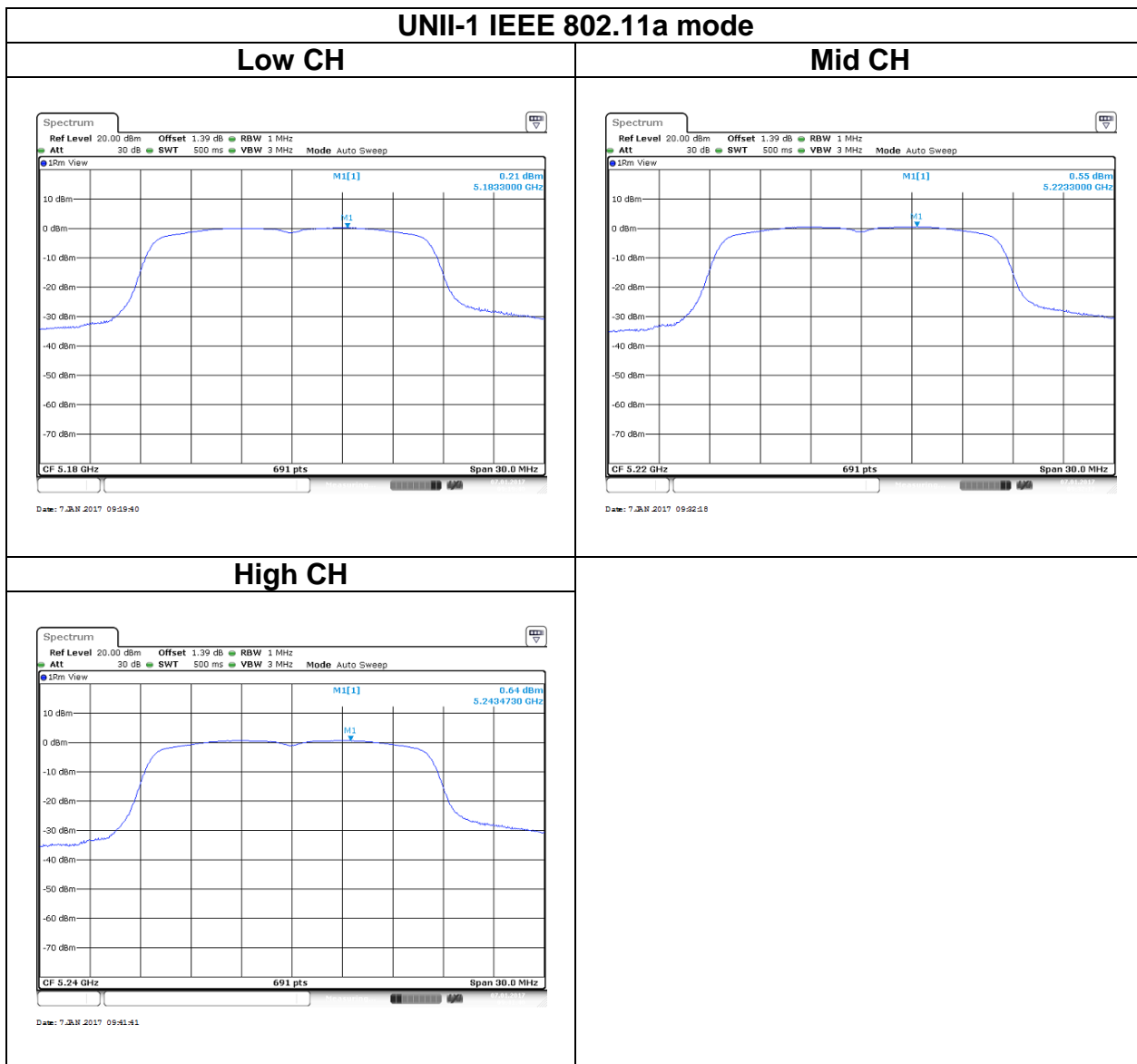

UNII-1 IEEE 802.11n HT20 mode

Low CH

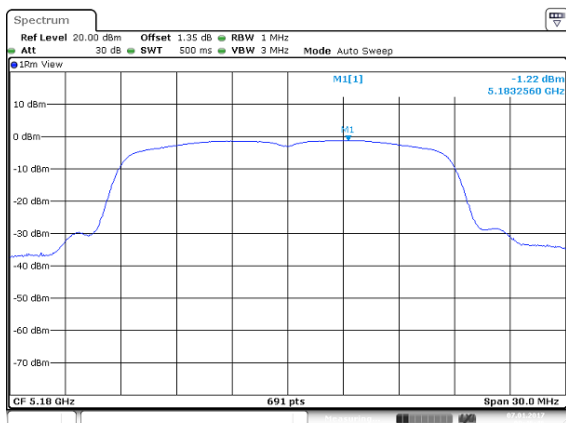

Mid CH

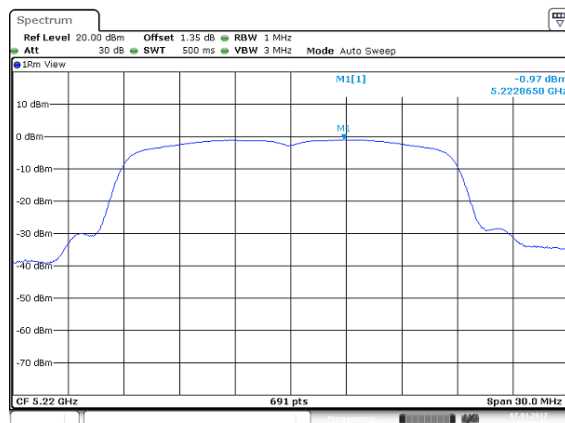

High CH

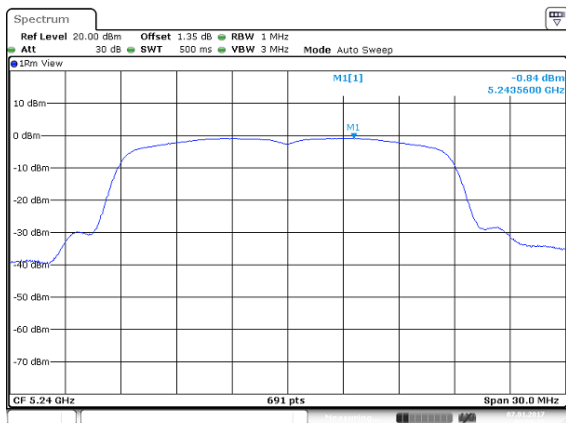

UNII-1 IEEE 802.11n HT40 mode

Low CH

High CH

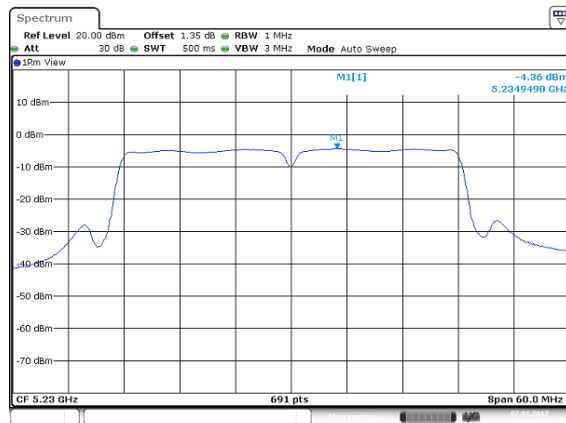
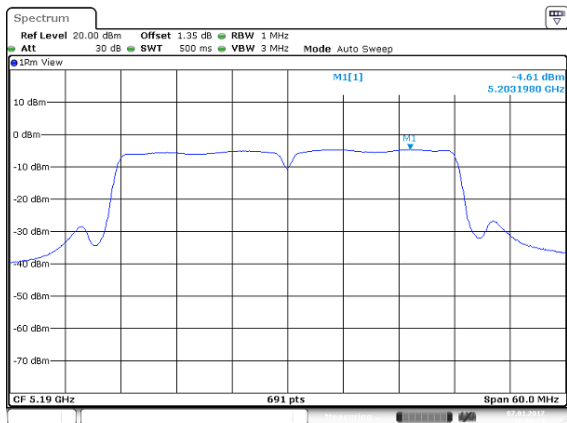

4.5 RADIATION BANDEDGE AND SPURIOUS EMISSION

4.5.1 Test Limit

According to §15.407, §15.209 and §15.205,

Below 30 MHz

Frequency	Field Strength (microvolts/m)	Magnetic H-Field (microamperes/m)	Measurement Distance (metres)
9-490 kHz	2,400/F (F in kHz)	2,400/F (F in kHz)	300
490-1,705 kHz	24,000/F (F in kHz)	24,000/F (F in kHz)	30
1.705-30 MHz	30	N/A	30

Above 30 MHz

Frequency (MHz)	Field Strength microvolts/m at 3 metres (watts, e.i.r.p.)	
	Transmitters	Receivers
30-88	100 (3 nW)	100 (3 nW)
88-216	150 (6.8 nW)	150 (6.8 nW)
216-960	200 (12 nW)	200 (12 nW)
Above 960	500 (75 nW)	500 (75 nW)

IC according to RSS-247 section 6.2.1.2

UNII-1 :

For transmitters operating in the band 5150-5250 MHz, all emissions outside the band 5150-5350 MHz shall not exceed -27 dBm/MHz e.i.r.p. However, any unwanted emissions that fall into the band 5250-5350 MHz must be 26 dBc, when measured using a resolution bandwidth between 1 and 5% of the occupied bandwidth, above 5.25 GHz. Otherwise, the transmission is considered as intentional and the devices shall implement dynamic frequency selection (DFS) and transmitter power control (TPC) as per the requirements for the band 5250-5350 MHz

4.5.2 Test Procedure

Test method Refer as KDB 789033 D02 v01r03, Section G.3, G.4, G.5, and G.6,.

1. The EUT is placed on a turntable, Above 1 GHz is 1.5m and below 1 GHz is 0.8m above ground plane. The EUT Configured un accordance with ANSI C63.10, and the EUT set in a continuous mode.
2. The turntable shall be rotated for 360 degrees to determine the position of maximum emission level. And EUT is set 3m away from the receiving antenna, which is scanned from 1m to 4m above the ground plane to find out the highest emissions. Measurement are made polarized in both the vertical and the horizontal positions with antenna.
3. Span shall wide enough to full capture the emission measured. The SA from 30MHz to 26.5GHz set to the low, Mid and High channels with the EUT transmit.
5. The SA setting following :
 - (1) Below 1G : RBW = 100kHz, VBW $\geq 3 \cdot RBW$, Sweep = Auto, Detector = Peak, Trace = Max hold.
 - (2) Above 1G :
 - (2.1) For Peak measurement : RBW = 1MHz, VBW $\geq 3 \cdot RBW$, Sweep = Auto, Detector = Peak, Trace = Max hold.
 - (2.2) For Average measurement : RBW = 1MHz, VBW
 - If Duty Cycle $\geq 98\%$, VBW=10Hz.
 - If Duty Cycle $< 98\%$, VBW=1/T.

Configuration	Duty Cycle (%)	VBW
802.11a	98.99	10Hz
802.11n HT20	99.00	10Hz
802.11n HT40	97.90	1.5kHz

4.5.3 Test Setup

9kHz ~ 30MHz

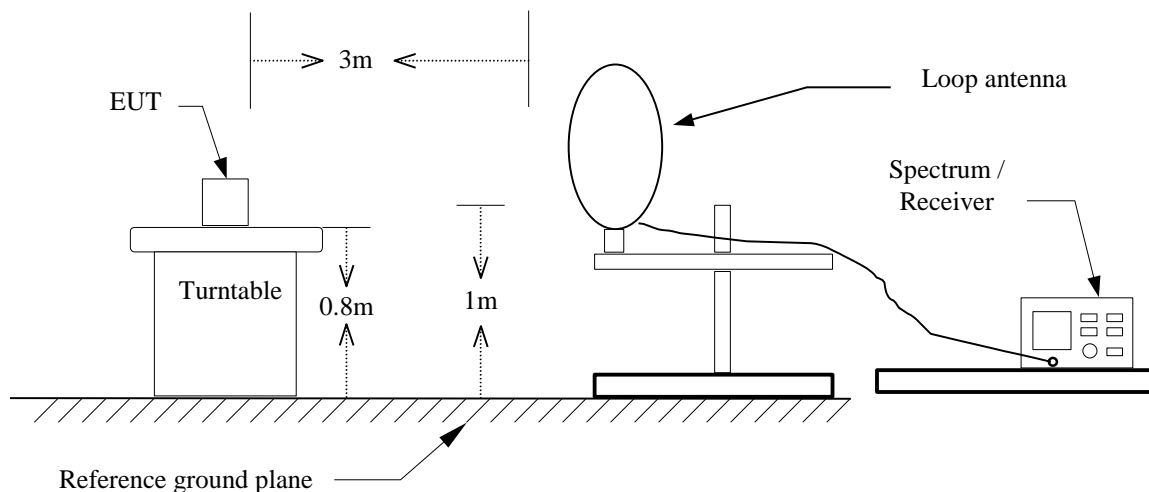

30MHz ~ 1GHz

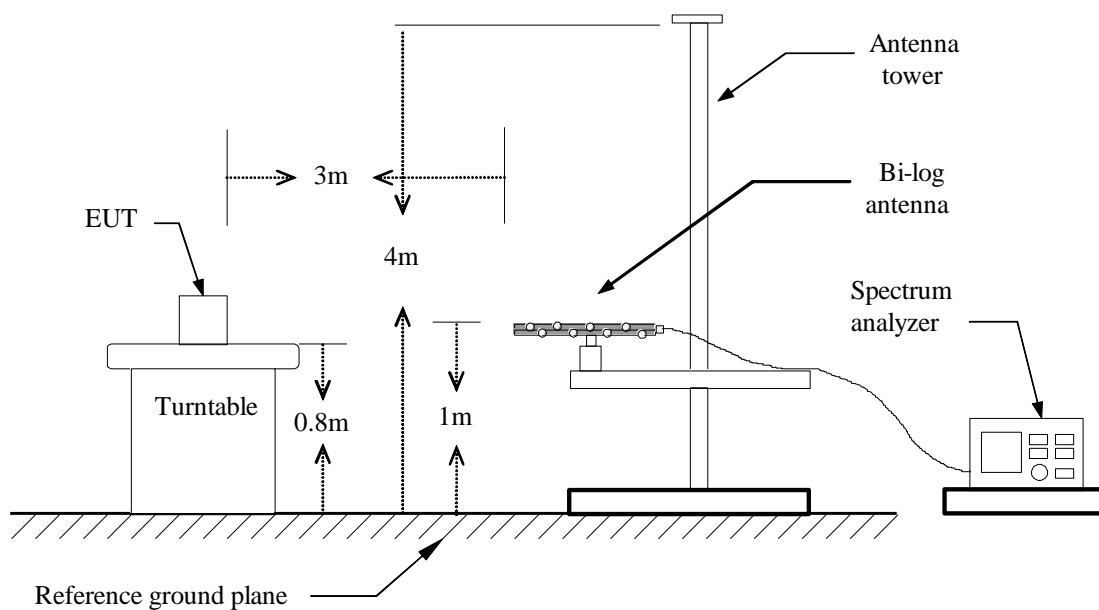

Above 1 GHz

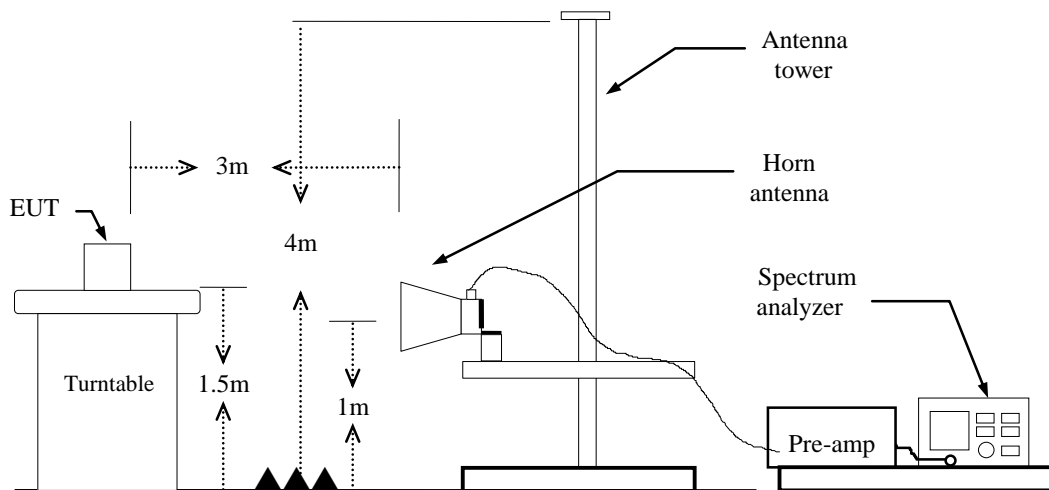

4.5.4 Test Result

Test Data

Band Edge Test Data for UNII-1

Test Mode	IEEE 802.11a Low CH	Temp/Hum	27(°C)/ 53%RH
Test Item	Band Edge	Test Date	Jan 18, 2017
Polarize	Vertical	Test Engineer	Kevin Kuo
Detector	Peak	Test Voltage	120Vac / 60Hz

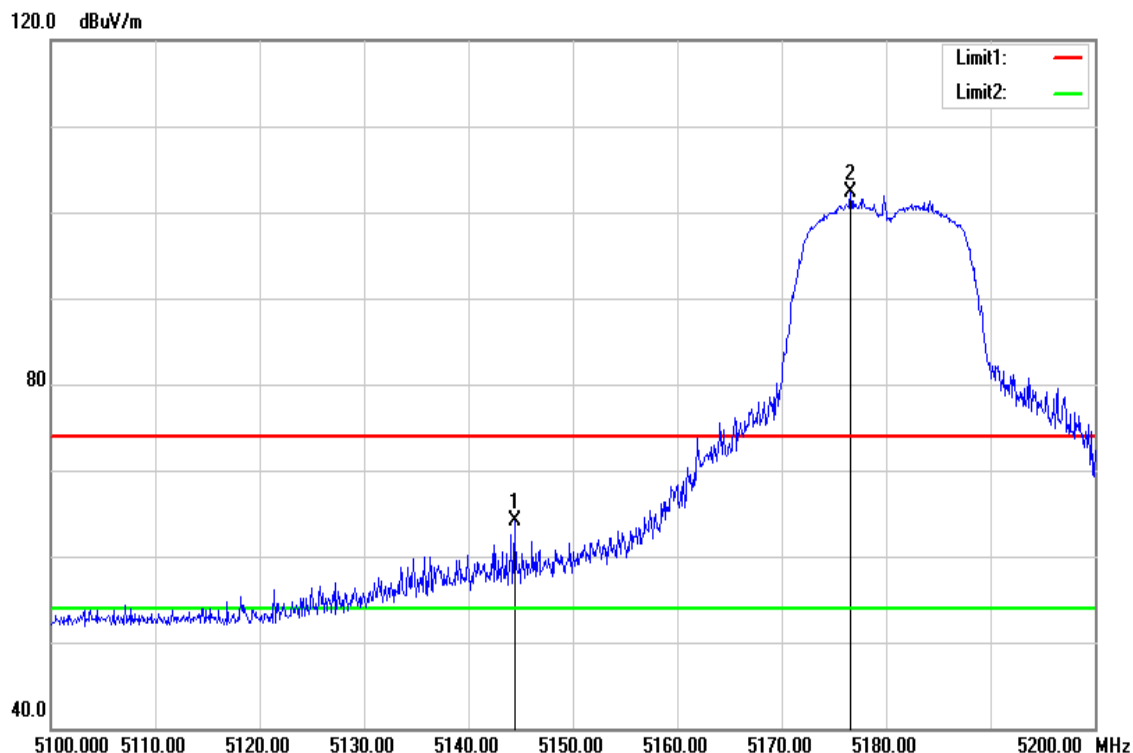

Frequency (MHz)	Reading (dBuV)	Correct Factor (dB/m)	Result (dBuV/m)	Limit (dBuV/m)	Margin (dB)	Remark
5144.400	61.13	3.00	64.13	74.00	-9.87	Peak
5176.600	98.49	3.81	102.30	-	-	Peak

Test Mode	IEEE 802.11a Low CH	Temperature	27(°C)/ 53%RH
Test Item	Band Edge	Test Date	Jan 18, 2017
Polarize	Vertical	Test Engineer	Kevin Kuo
Detector	Average	Test Voltage	120Vac / 60Hz

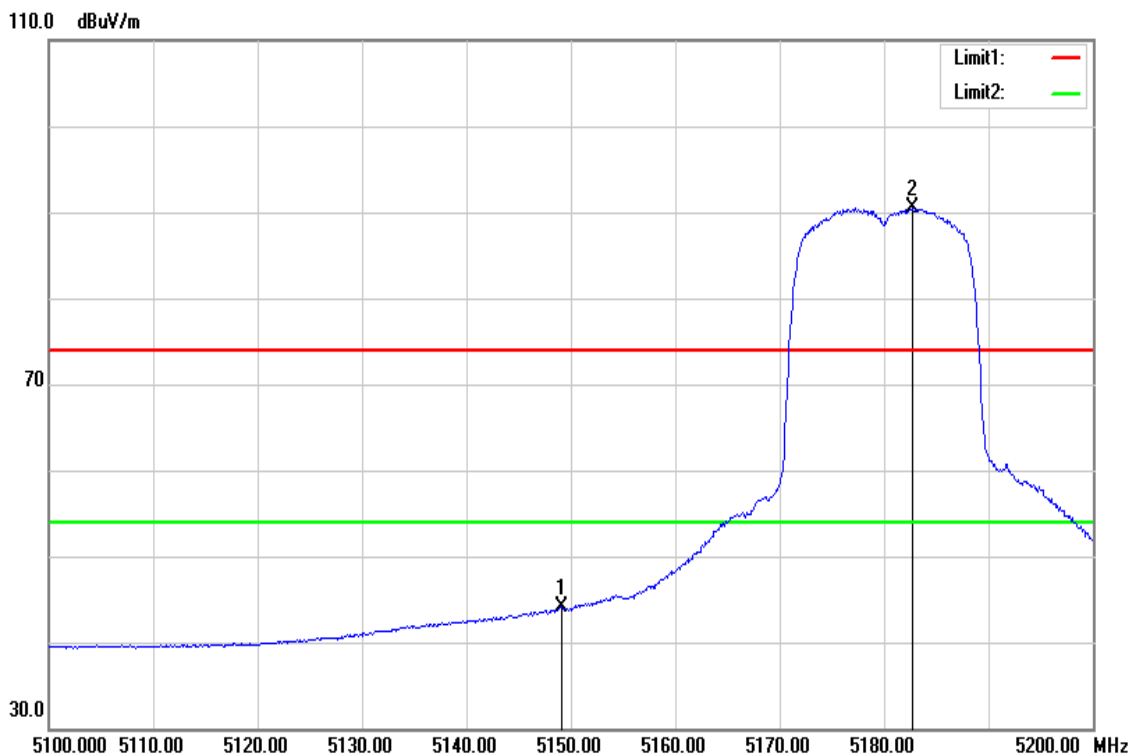

Frequency (MHz)	Reading (dBuV)	Correct Factor (dB/m)	Result (dBuV/m)	Limit (dBuV/m)	Margin (dB)	Remark
5149.100	40.99	3.03	44.02	54.00	-9.98	AVG
5182.700	86.45	3.99	90.44	-	-	AVG

Test Mode	IEEE 802.11a High CH	Temp/Hum	27(°C)/ 53%RH
Test Item	Band Edge	Test Date	Jan 18, 2017
Polarize	Vertical	Test Engineer	Kevin Kuo
Detector	Peak	Test Voltage	120Vac / 60Hz

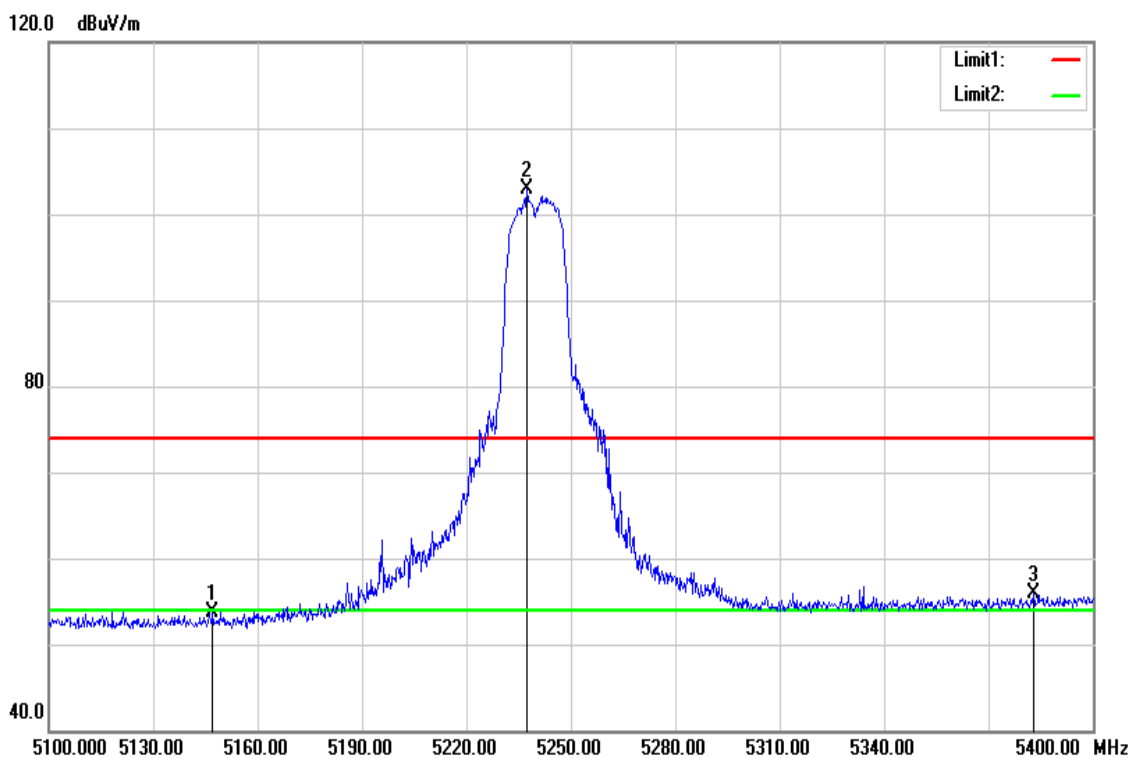

Frequency (MHz)	Reading (dBuV)	Correct Factor (dB/m)	Result (dBuV/m)	Limit (dBuV/m)	Margin (dB)	Remark
5147.100	50.73	3.02	53.75	74.00	-20.25	Peak
5237.400	98.35	4.62	102.97	-	-	Peak
5382.900	50.28	5.58	55.86	74.00	-18.14	Peak

Test Mode	IEEE 802.11a High CH	Temperature	27(°C)/ 53%RH
Test Item	Band Edge	Test Date	Jan 18, 2017
Polarize	Vertical	Test Engineer	Kevin Kuo
Detector	Average	Test Voltage	120Vac / 60Hz

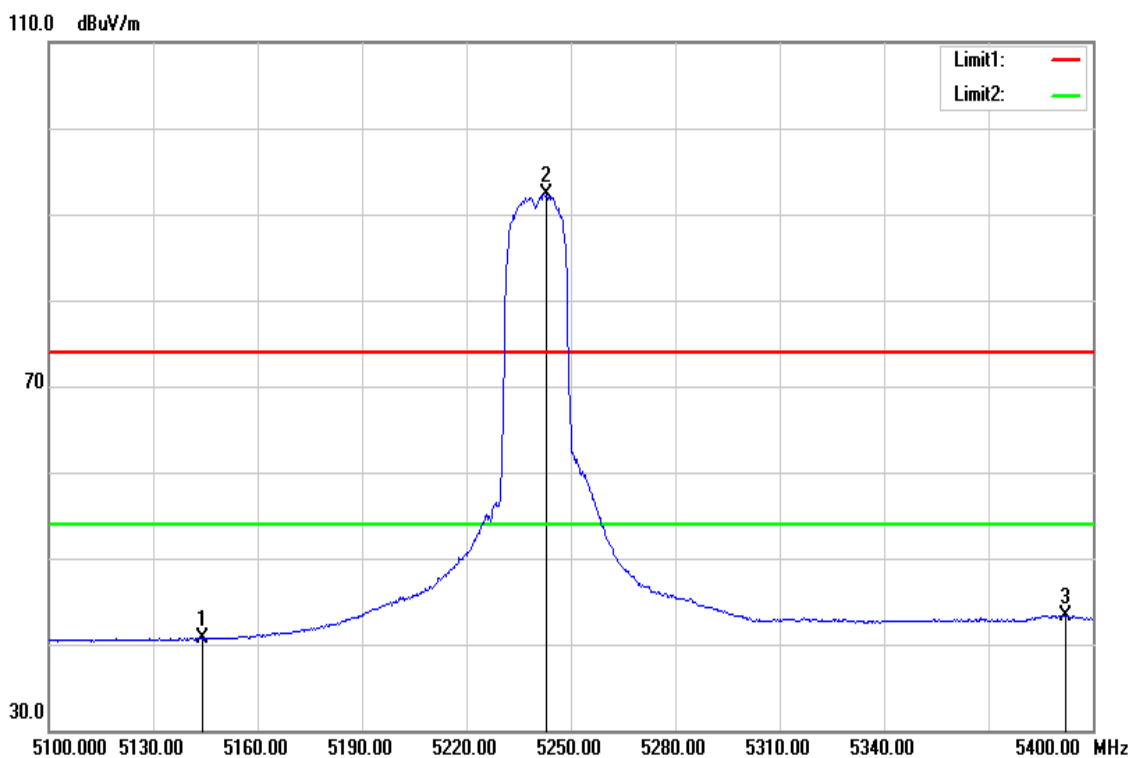

Frequency (MHz)	Reading (dBuV)	Correct Factor (dB/m)	Result (dBuV/m)	Limit (dBuV/m)	Margin (dB)	Remark
5144.100	37.72	3.00	40.72	54.00	-13.28	AVG
5243.100	87.76	4.64	92.40	-	-	AVG
5392.200	37.72	5.66	43.38	54.00	-10.62	AVG

Test Mode	IEEE 802.11n HT20 Low CH	Temp/Hum	27(°C)/ 53%RH
Test Item	Band Edge	Test Date	Jan 18, 2017
Polarize	Vertical	Test Engineer	Kevin Kuo
Detector	Peak	Test Voltage	120Vac / 60Hz

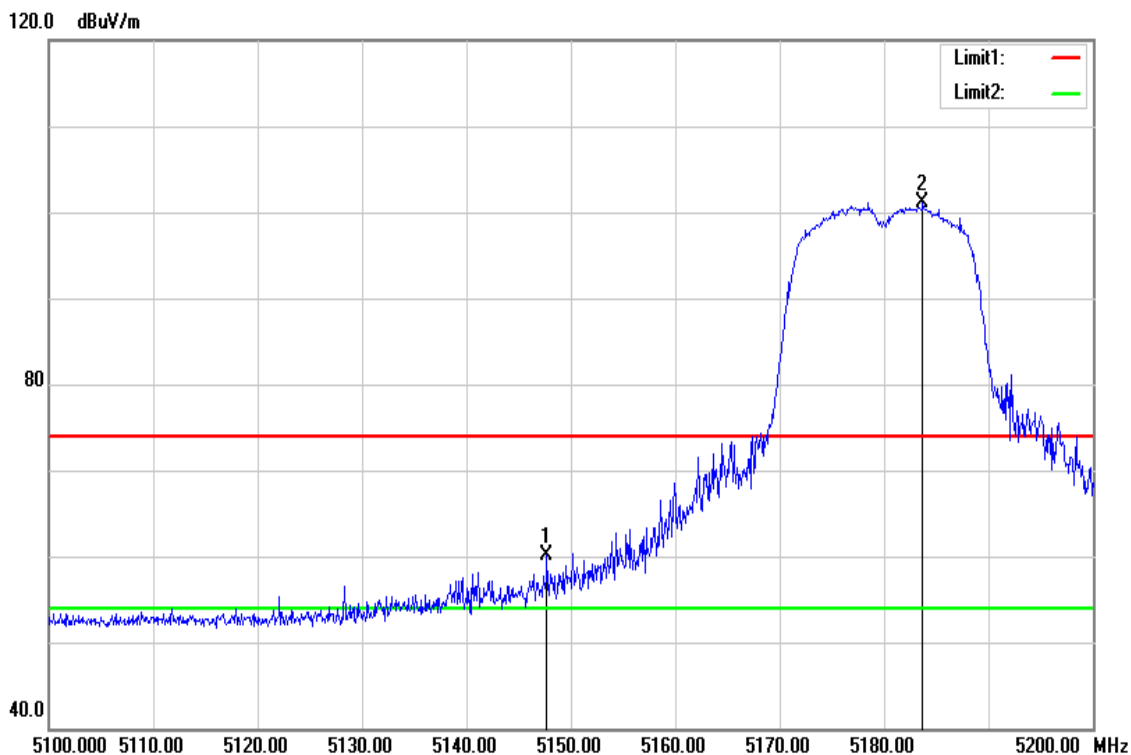

Frequency (MHz)	Reading (dBuV)	Correct Factor (dB/m)	Result (dBuV/m)	Limit (dBuV/m)	Margin (dB)	Remark
5147.700	57.08	3.02	60.10	74.00	-13.90	Peak
5183.700	97.06	4.02	101.08	-	-	Peak

Test Mode	IEEE 802.11n HT20 Low CH	Temperature	27(°C)/ 53%RH
Test Item	Band Edge	Test Date	Jan 18, 2017
Polarize	Vertical	Test Engineer	Kevin Kuo
Detector	Average	Test Voltage	120Vac / 60Hz

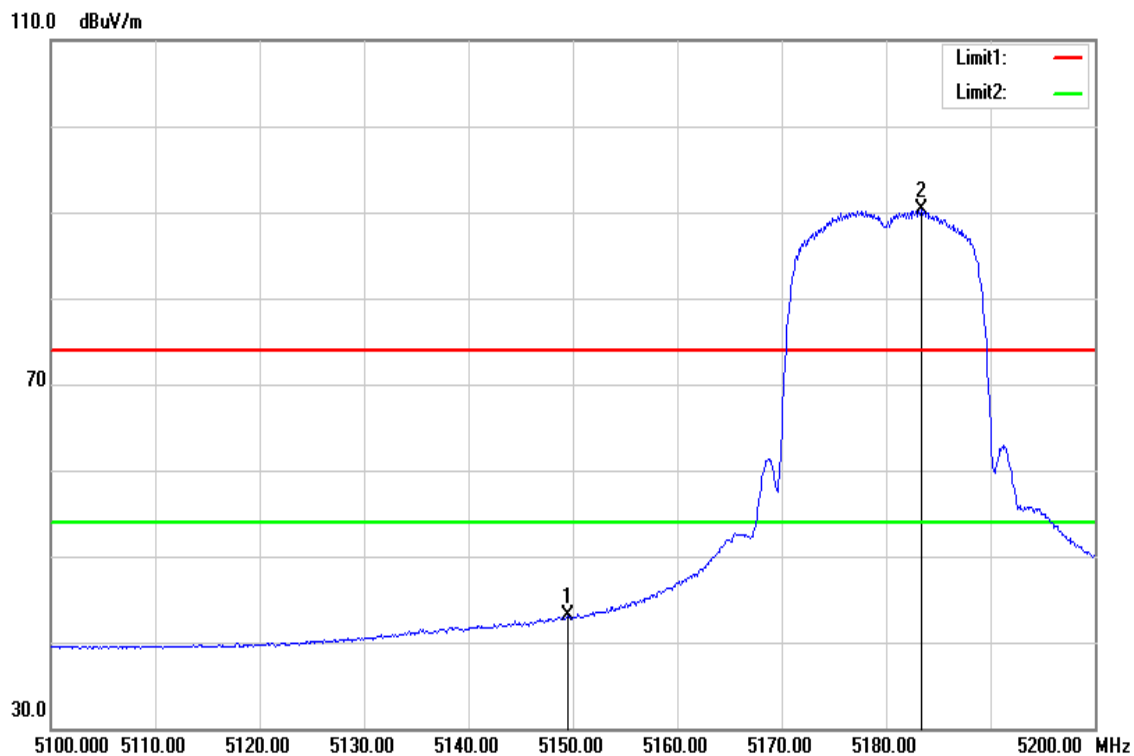

Frequency (MHz)	Reading (dBuV)	Correct Factor (dB/m)	Result (dBuV/m)	Limit (dBuV/m)	Margin (dB)	Remark
5149.500	39.97	3.04	43.01	54.00	-10.99	AVG
5183.400	86.21	4.01	90.22	-	-	AVG

Test Mode	IEEE 802.11n HT20 High CH	Temp/Hum	27(°C)/ 53%RH
Test Item	Band Edge	Test Date	Jan 18, 2017
Polarize	Vertical	Test Engineer	Kevin Kuo
Detector	Peak	Test Voltage	120Vac / 60Hz

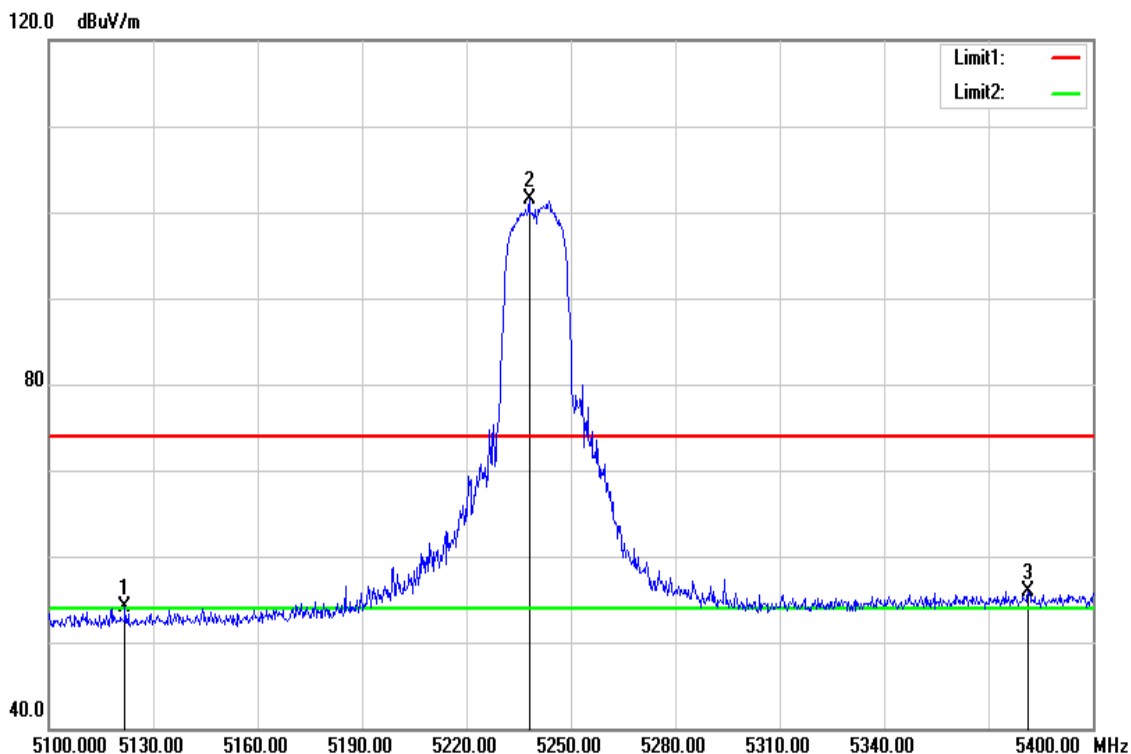

Frequency (MHz)	Reading (dBuV)	Correct Factor (dB/m)	Result (dBuV/m)	Limit (dBuV/m)	Margin (dB)	Remark
5121.900	51.20	2.85	54.05	74.00	-19.95	Peak
5238.000	96.87	4.62	101.49	-	-	Peak
5381.400	50.40	5.57	55.97	74.00	-18.03	Peak

Test Mode	IEEE 802.11n HT20 High CH	Temperature	27(°C)/ 53%RH
Test Item	Band Edge	Test Date	Jan 18, 2017
Polarize	Vertical	Test Engineer	Kevin Kuo
Detector	Average	Test Voltage	120Vac / 60Hz

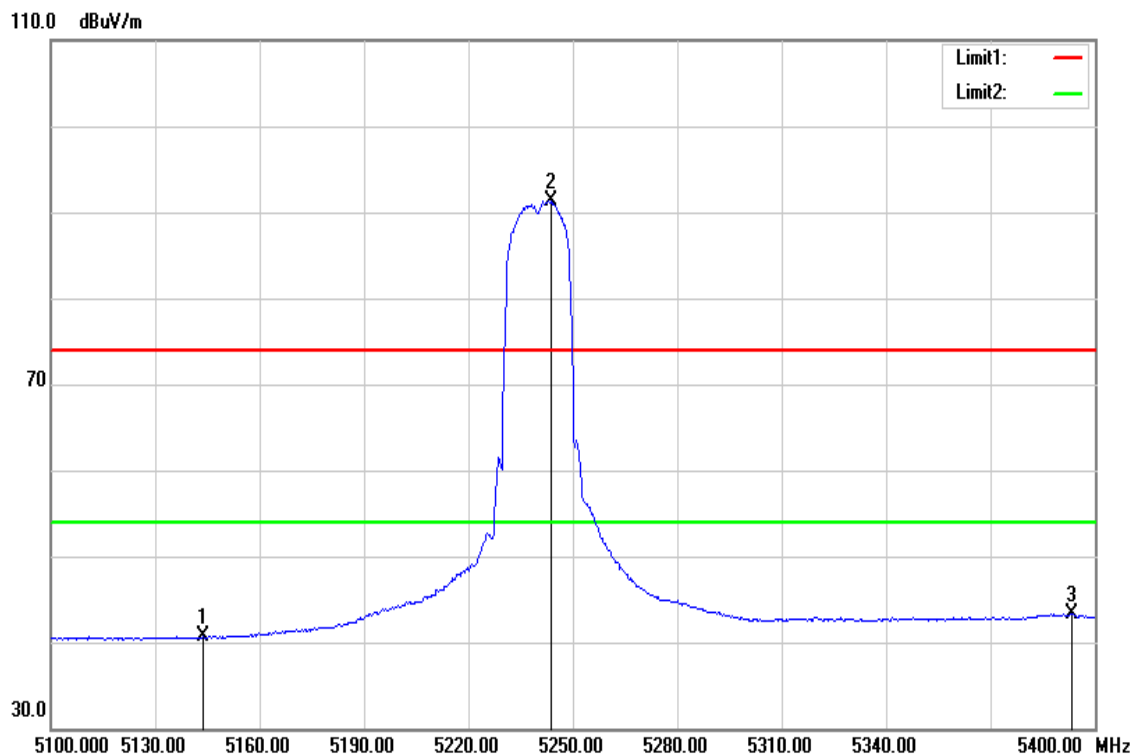

Frequency (MHz)	Reading (dBuV)	Correct Factor (dB/m)	Result (dBuV/m)	Limit (dBuV/m)	Margin (dB)	Remark
5143.800	37.69	3.00	40.69	54.00	-13.31	AVG
5243.700	86.74	4.64	91.38	-	-	AVG
5393.400	37.60	5.67	43.27	54.00	-10.73	AVG

Test Mode	IEEE 802.11n HT40 Low CH	Temp/Hum	27(°C)/ 53%RH
Test Item	Band Edge	Test Date	Jan 18, 2017
Polarize	Vertical	Test Engineer	Kevin Kuo
Detector	Peak	Test Voltage	120Vac / 60Hz

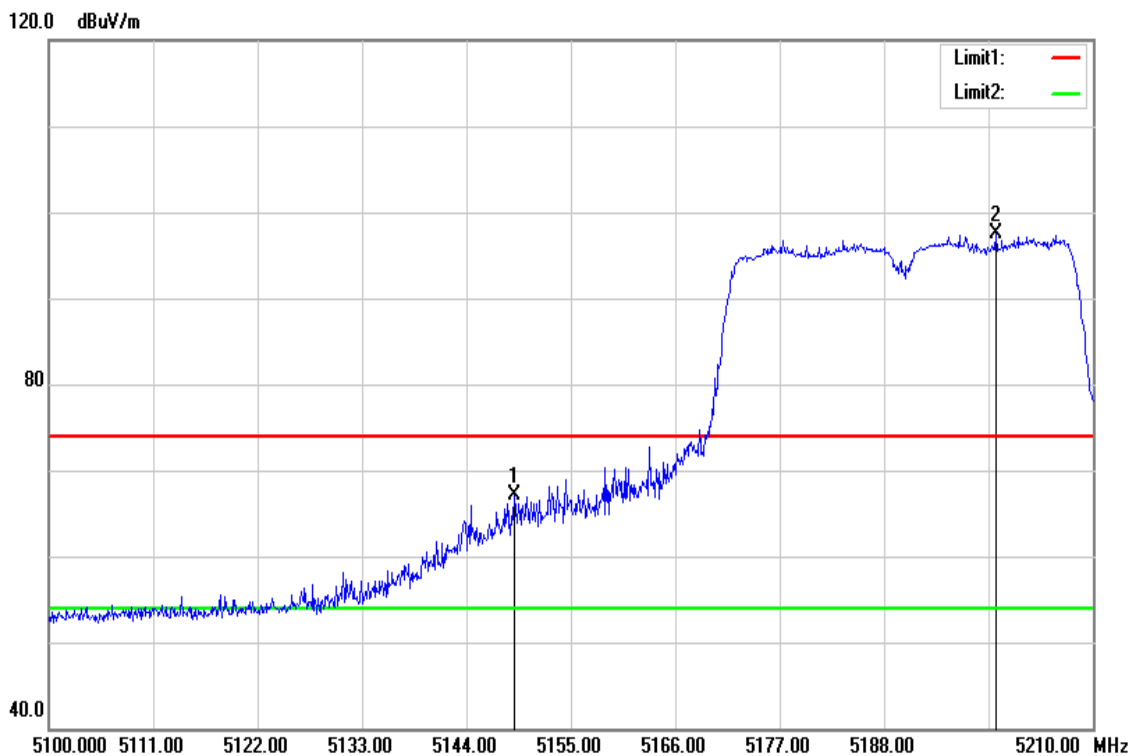

Frequency (MHz)	Reading (dBuV)	Correct Factor (dB/m)	Result (dBuV/m)	Limit (dBuV/m)	Margin (dB)	Remark
5149.060	64.04	3.03	67.07	74.00	-6.93	Peak
5199.770	93.00	4.48	97.48	-	-	Peak

Test Mode	IEEE 802.11n HT40 Low CH	Temperature	27(°C)/ 53%RH
Test Item	Band Edge	Test Date	Jan 18, 2017
Polarize	Vertical	Test Engineer	Kevin Kuo
Detector	Average	Test Voltage	120Vac / 60Hz

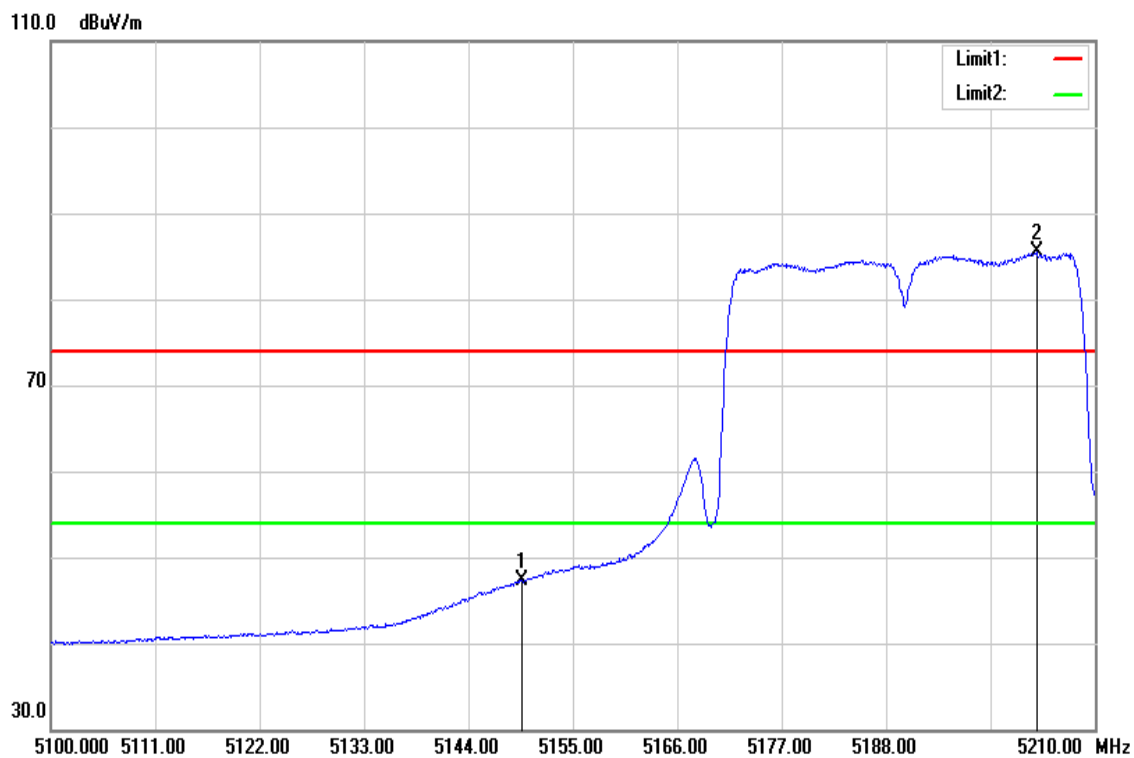

Frequency (MHz)	Reading (dBuV)	Correct Factor (dB/m)	Result (dBuV/m)	Limit (dBuV/m)	Margin (dB)	Remark
5149.610	44.32	3.04	47.36	54.00	-6.64	AVG
5203.840	80.98	4.50	85.48	-	-	AVG

Test Mode	IEEE 802.11n HT40 High CH	Temp/Hum	27(°C)/ 53%RH
Test Item	Band Edge	Test Date	Jan 18, 2017
Polarize	Vertical	Test Engineer	Kevin Kuo
Detector	Peak	Test Voltage	120Vac / 60Hz

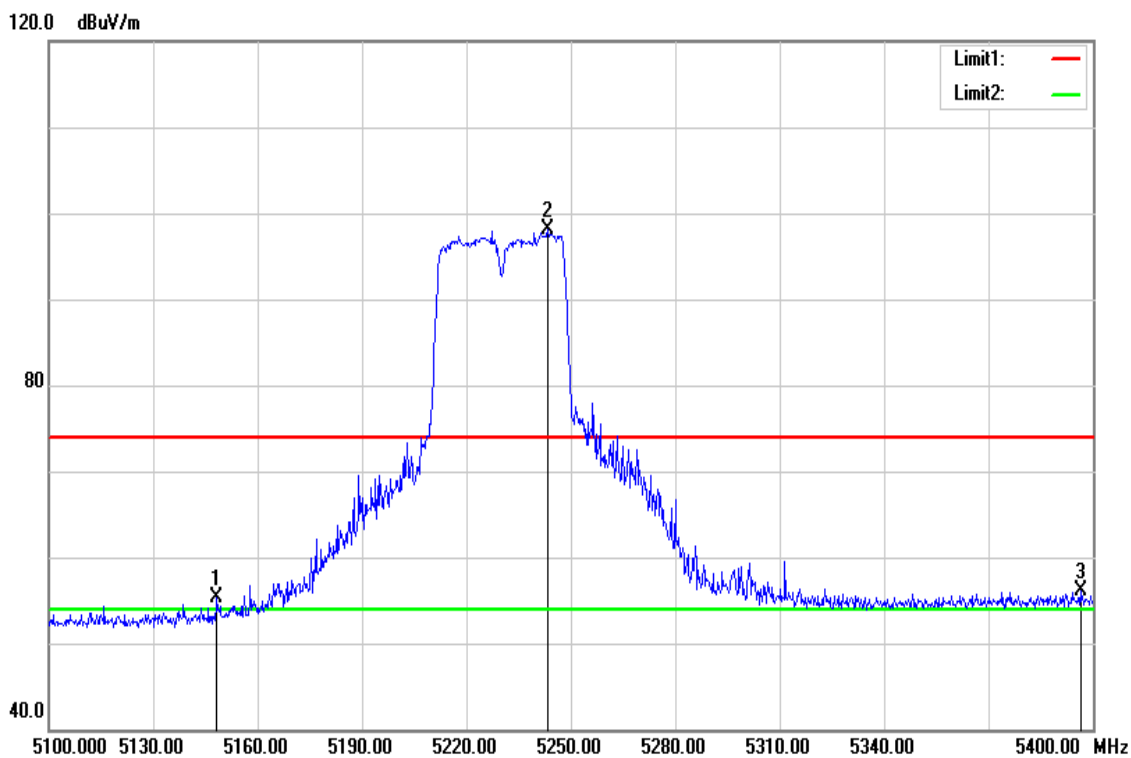

Frequency (MHz)	Reading (dBuV)	Correct Factor (dB/m)	Result (dBuV/m)	Limit (dBuV/m)	Margin (dB)	Remark
5148.300	52.36	3.03	55.39	74.00	-18.61	Peak
5243.400	93.44	4.64	98.08	-	-	Peak
5396.400	50.36	5.69	56.05	74.00	-17.95	Peak

Test Mode	IEEE 802.11n HT40 High CH	Temperature	27(°C)/ 53%RH
Test Item	Band Edge	Test Date	Jan 18, 2017
Polarize	Vertical	Test Engineer	Kevin Kuo
Detector	Average	Test Voltage	120Vac / 60Hz

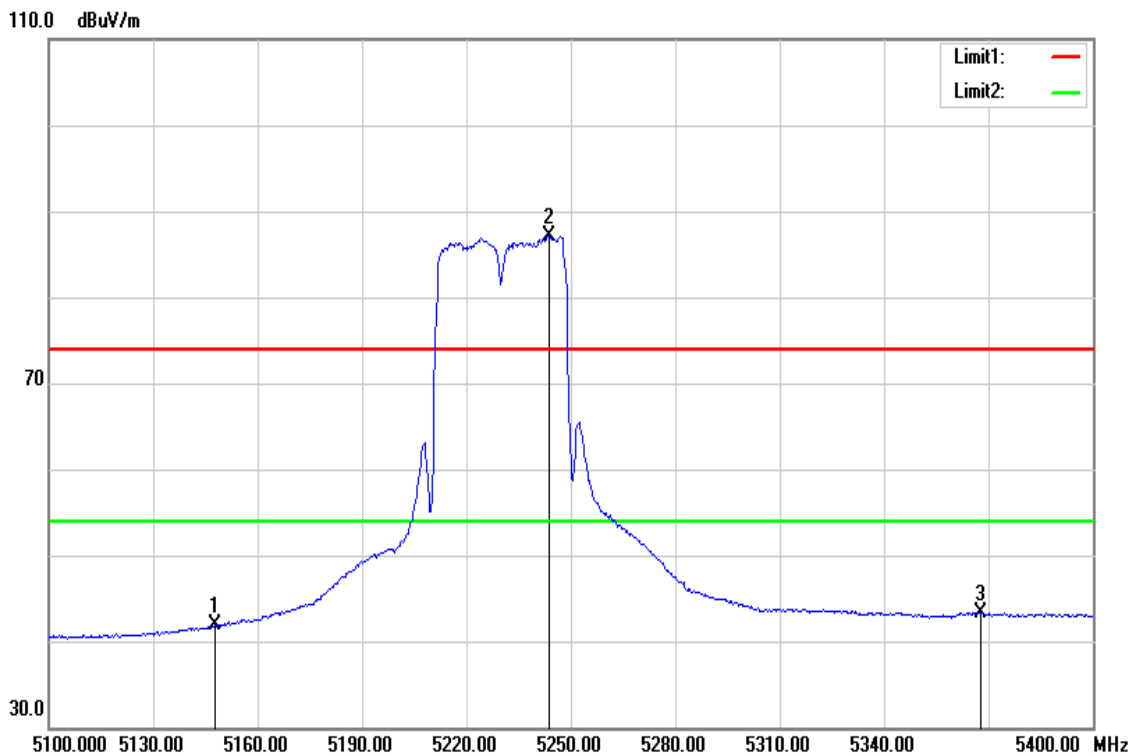

Frequency (MHz)	Reading (dBuV)	Correct Factor (dB/m)	Result (dBuV/m)	Limit (dBuV/m)	Margin (dB)	Remark
5147.700	38.83	3.02	41.85	54.00	-12.15	AVG
5243.700	82.45	4.64	87.09	-	-	AVG
5367.900	37.94	5.46	43.40	54.00	-10.60	AVG

Below 1G Test Data

Test Mode	Mode 1	Temp/Hum	27(°C)/ 53%RH
Test Item	30MHz-1GHz	Test Date	Jan 18, 2017
Polarize	Vertical	Test Engineer	Kevin Kuo
Detector	Peak and Qusi-peak	Test Voltage	120Vac / 60Hz

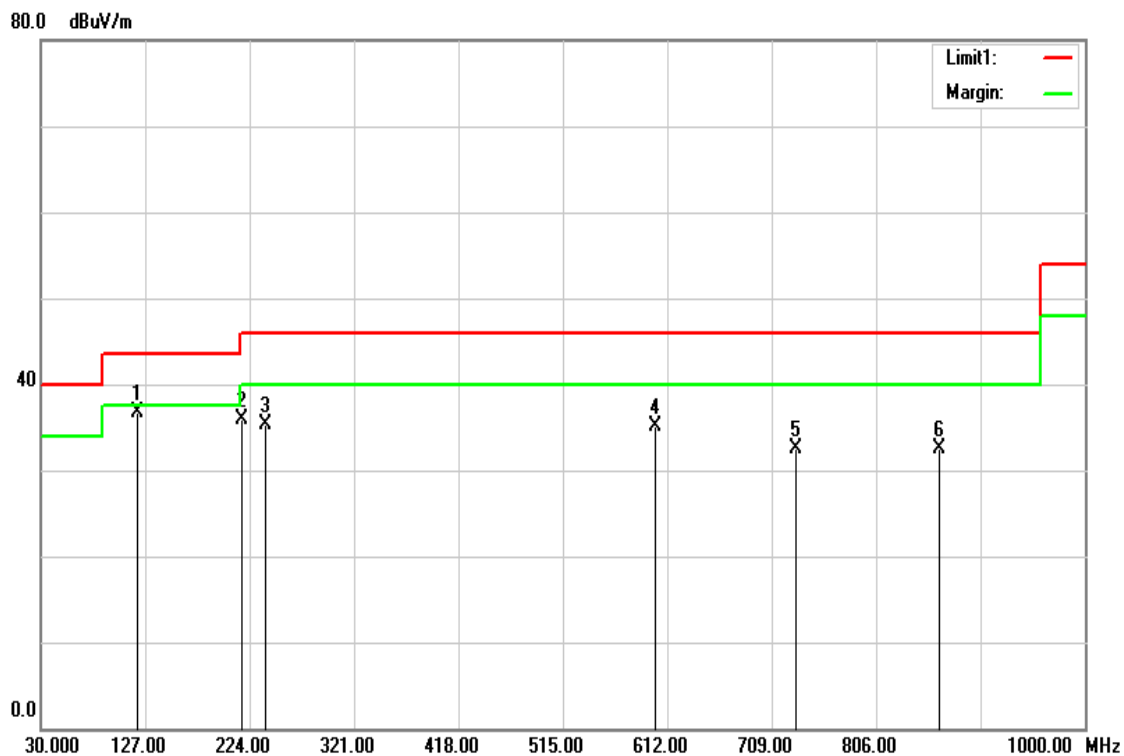

Frequency (MHz)	Reading (dBuV)	Correct Factor (dB/m)	Result (dBuV/m)	Limit (dBuV/m)	Margin (dB)	Remark
120.2100	52.23	-15.50	36.73	43.50	-6.77	Peak
216.2400	52.56	-16.69	35.87	46.00	-10.13	Peak
238.5500	51.93	-16.54	35.39	46.00	-10.61	Peak
600.3600	42.77	-7.75	35.02	46.00	-10.98	Peak
731.3100	37.77	-5.35	32.42	46.00	-13.58	Peak
864.2000	36.09	-3.61	32.48	46.00	-13.52	Peak

Test Mode	Mode 1	Temp/Hum	27(°C)/ 53%RH
Test Item	30MHz-1GHz	Test Date	Jan 18, 2017
Polarize	Vertical	Test Engineer	Kevin Kuo
Detector	Peak and Qusi-peak	Test Voltage	120Vac / 60Hz

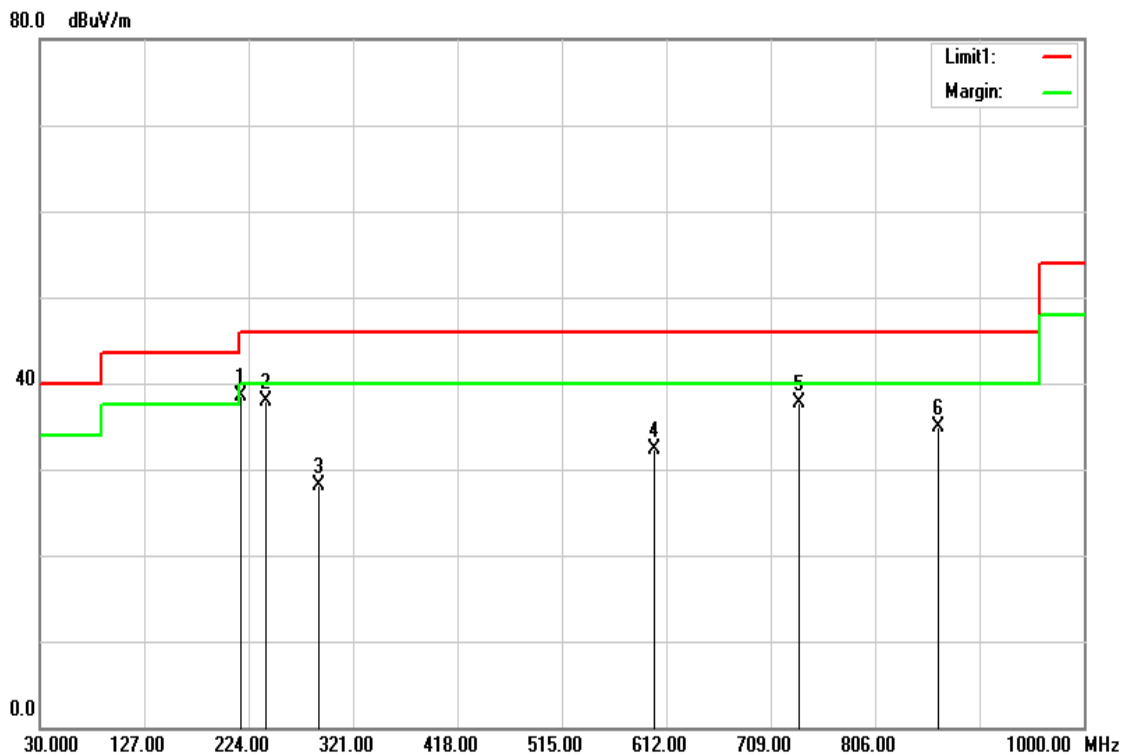

Frequency (MHz)	Reading (dBuV)	Correct Factor (dB/m)	Result (dBuV/m)	Limit (dBuV/m)	Margin (dB)	Remark
216.2400	55.15	-16.69	38.46	46.00	-7.54	Peak
240.4900	54.42	-16.50	37.92	46.00	-8.08	Peak
288.9900	42.48	-14.45	28.03	46.00	-17.97	Peak
600.3600	40.12	-7.75	32.37	46.00	-13.63	Peak
735.1900	42.88	-5.26	37.62	46.00	-8.38	Peak
865.1700	38.42	-3.60	34.82	46.00	-11.18	Peak

Above 1G Test Data

Test Mode	IEEE 802.11a Low CH	Temp/Hum	27(°C)/ 53%RH
Test Item	Harmonic	Test Date	Jan 18, 2017
Polarize	Vertical	Test Engineer	Kevin Kuo
Detector	Peak and Average	Test Voltage	120Vac / 60Hz

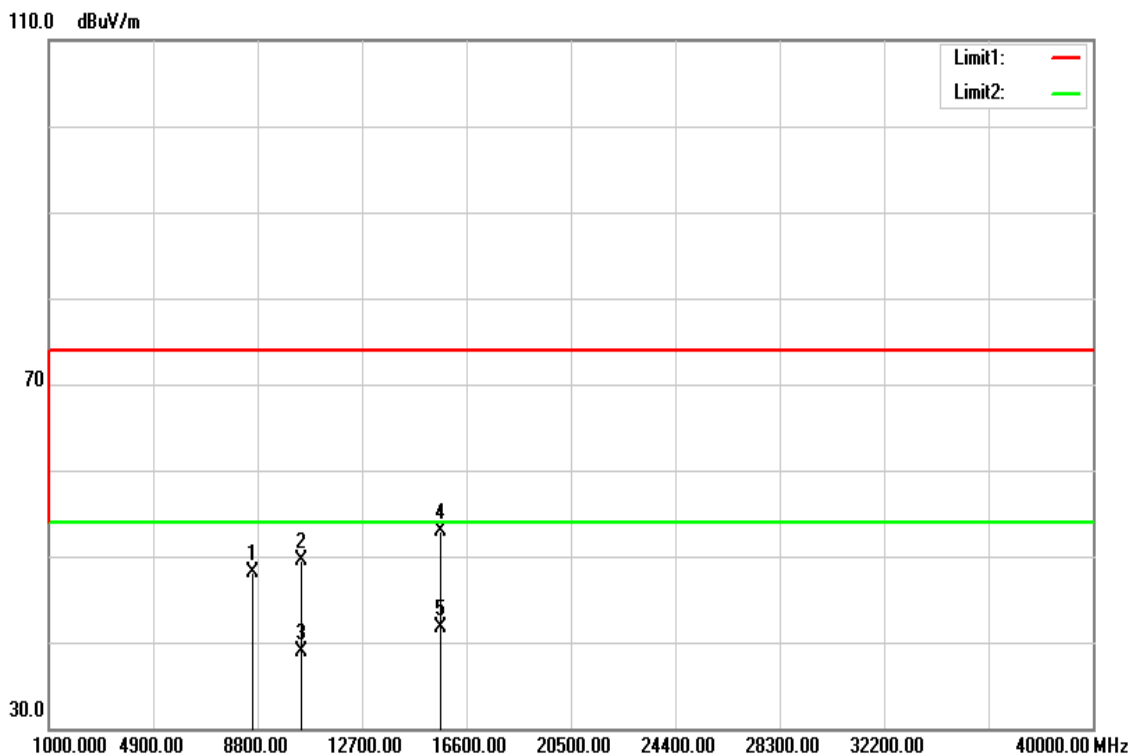

Frequency (MHz)	Reading (dBuV)	Correct Factor (dB/m)	Result (dBuV/m)	Limit (dBuV/m)	Margin (dB)	Remark
8620.000	32.80	15.31	48.11	74.00	-25.89	Peak
10440.000	31.86	17.57	49.43	74.00	-24.57	Peak
10440.000	21.35	17.57	38.92	54.00	-15.08	AVG
15660.000	31.96	21.02	52.98	74.00	-21.02	Peak
15660.000	20.65	21.02	41.67	54.00	-12.33	AVG

Remark:

1. Measuring frequencies from 1 GHz to the 10th harmonic of highest fundamental frequency.
2. For above 1GHz, the EUT peak value was under average limit, therefore the Average value compliance with the average limit

Test Mode	IEEE 802.11a Low CH	Temp/Hum	27(°C)/ 53%RH
Test Item	Harmonic	Test Date	Jan 18, 2017
Polarize	Horizontal	Test Engineer	Kevin Kuo
Detector	Peak and Average	Test Voltage	120Vac / 60Hz

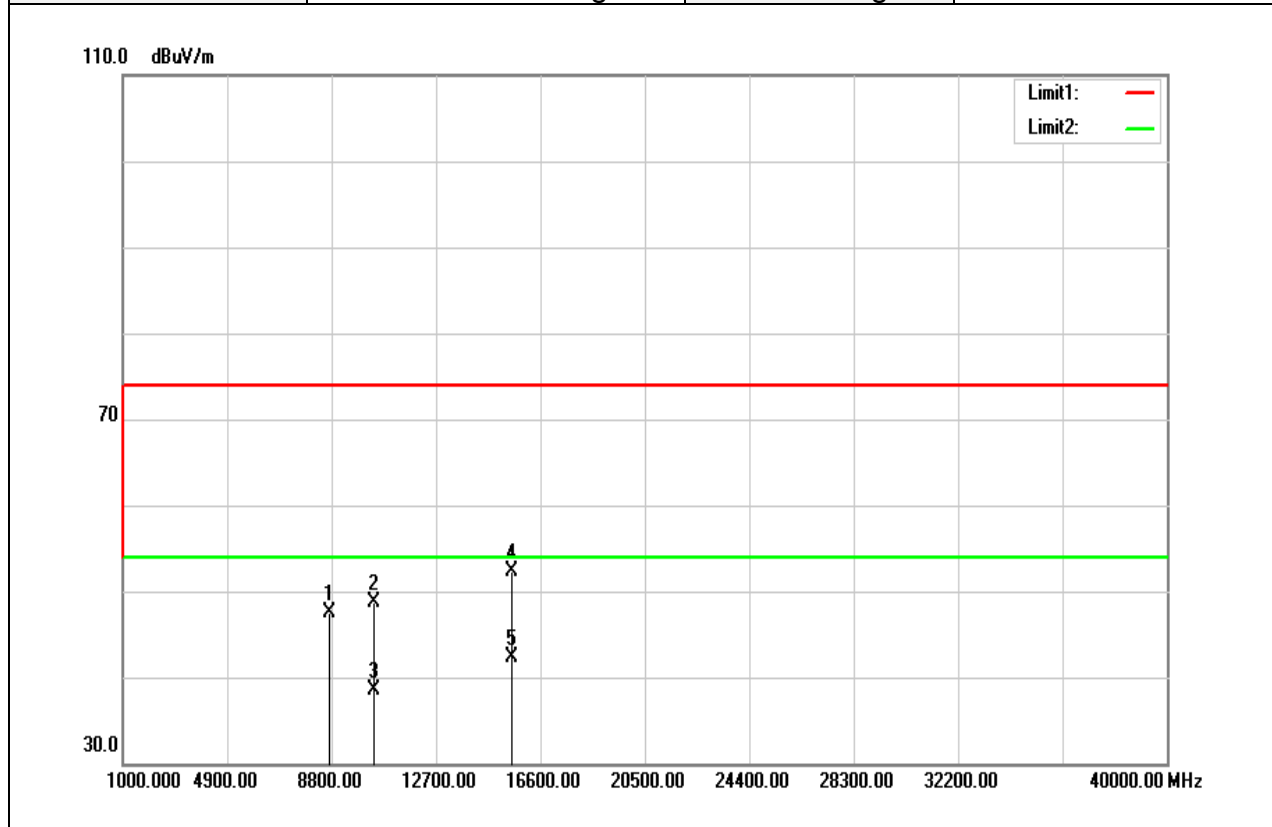

Frequency (MHz)	Reading (dBuV)	Correct Factor (dB/m)	Result (dBuV/m)	Limit (dBuV/m)	Margin (dB)	Remark
8740.000	31.94	15.53	47.47	74.00	-26.53	Peak
10360.000	31.10	17.58	48.68	74.00	-25.32	Peak
10360.000	20.99	17.58	38.57	54.00	-15.43	AVG
15540.000	31.69	20.61	52.30	74.00	-21.70	Peak
15540.000	21.78	20.61	42.39	54.00	-11.61	AVG

Remark:

1. Measuring frequencies from 1 GHz to the 10th harmonic of highest fundamental frequency.
2. For above 1GHz, the EUT peak value was under average limit, therefore the Average value compliance with the average limit

Test Mode	IEEE 802.11a Mid CH	Temp/Hum	27(°C)/ 53%RH
Test Item	Harmonic	Test Date	Jan 18, 2017
Polarize	Vertical	Test Engineer	Kevin Kuo
Detector	Peak and Average	Test Voltage	120Vac / 60Hz

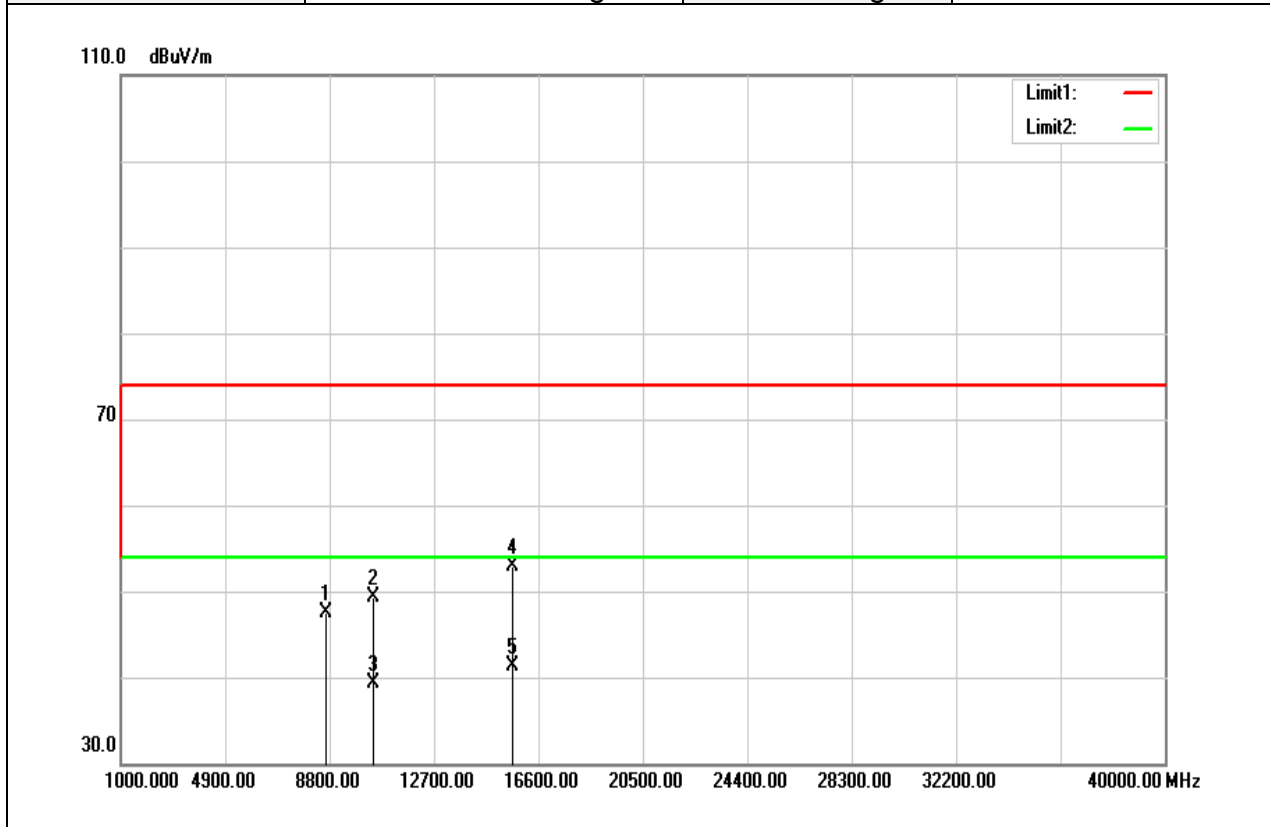

Frequency (MHz)	Reading (dBuV)	Correct Factor (dB/m)	Result (dBuV/m)	Limit (dBuV/m)	Margin (dB)	Remark
8690.000	32.14	15.44	47.58	74.00	-26.42	Peak
10440.000	31.75	17.57	49.32	74.00	-24.68	Peak
10440.000	21.71	17.57	39.28	54.00	-14.72	AVG
15660.000	31.83	21.02	52.85	74.00	-21.15	Peak
15660.000	20.28	21.02	41.30	54.00	-12.70	AVG

Remark:

1. Measuring frequencies from 1 GHz to the 10th harmonic of highest fundamental frequency.
2. For above 1GHz, the EUT peak value was under average limit, therefore the Average value compliance with the average limit

Test Mode	IEEE 802.11a Mid CH	Temp/Hum	27(°C)/ 53%RH
Test Item	Harmonic	Test Date	Jan 18, 2017
Polarize	Horizontal	Test Engineer	Kevin Kuo
Detector	Peak and Average	Test Voltage	120Vac / 60Hz

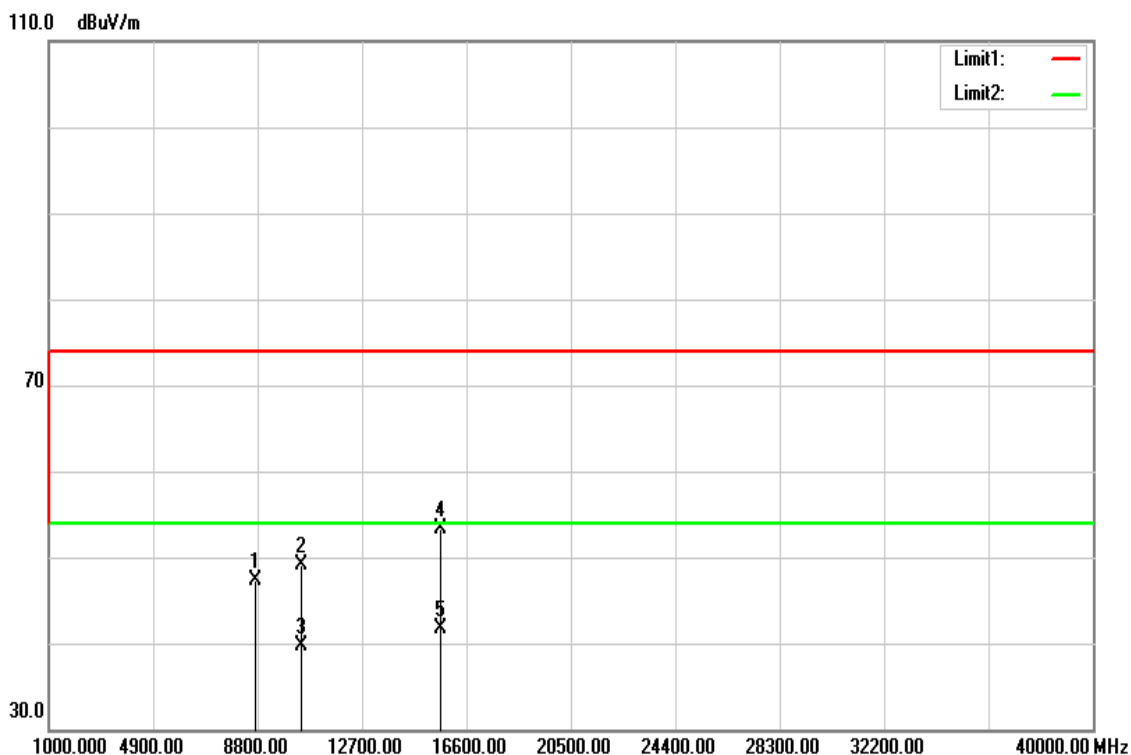

Frequency (MHz)	Reading (dBuV)	Correct Factor (dB/m)	Result (dBuV/m)	Limit (dBuV/m)	Margin (dB)	Remark
8720.000	31.83	15.49	47.32	74.00	-26.68	Peak
10440.000	31.46	17.57	49.03	74.00	-24.97	Peak
10440.000	22.06	17.57	39.63	54.00	-14.37	AVG
15660.000	32.25	21.02	53.27	74.00	-20.73	Peak
15660.000	20.69	21.02	41.71	54.00	-12.29	AVG

Remark:

1. Measuring frequencies from 1 GHz to the 10th harmonic of highest fundamental frequency.
2. For above 1GHz, the EUT peak value was under average limit, therefore the Average value compliance with the average limit

Test Mode	IEEE 802.11a High CH	Temp/Hum	27(°C)/ 53%RH
Test Item	Harmonic	Test Date	Jan 18, 2017
Polarize	Vertical	Test Engineer	Kevin Kuo
Detector	Peak and Average	Test Voltage	120Vac / 60Hz

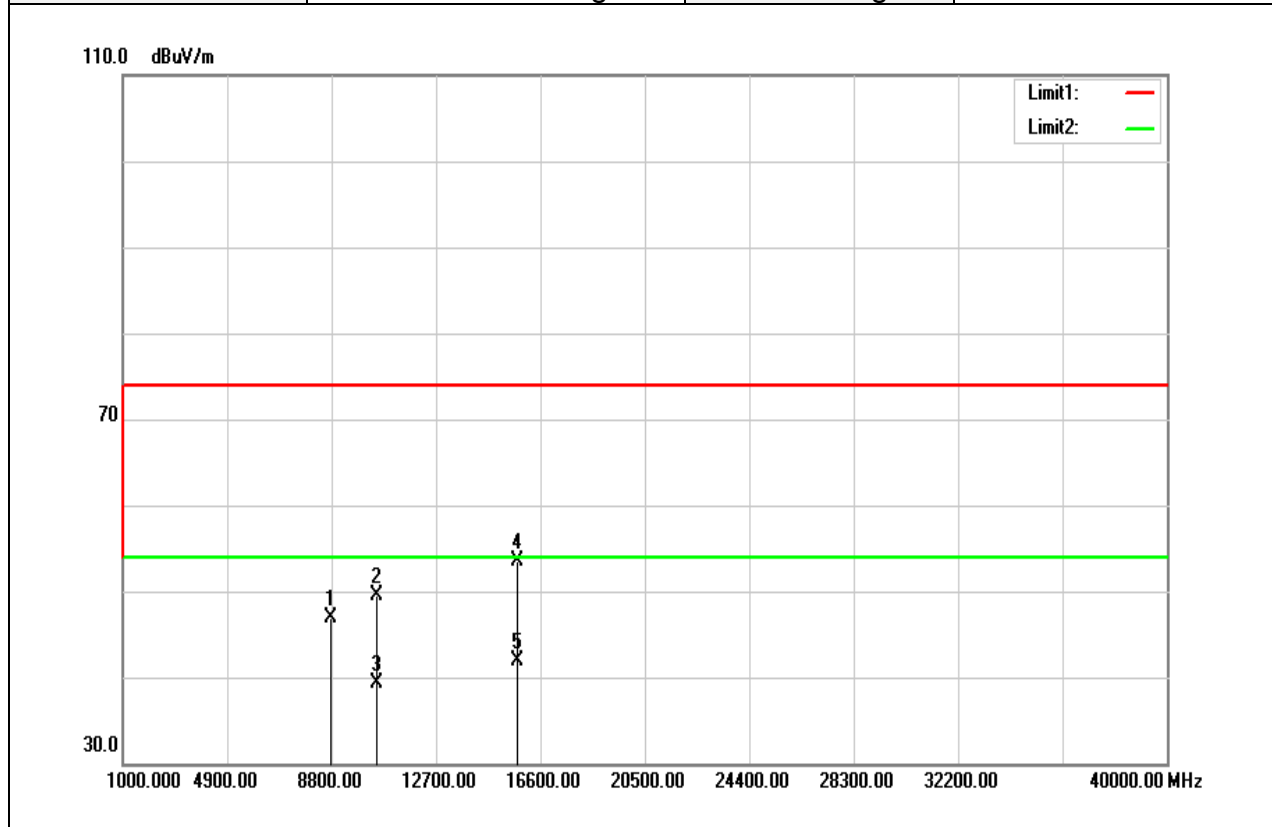

Frequency (MHz)	Reading (dBuV)	Correct Factor (dB/m)	Result (dBuV/m)	Limit (dBuV/m)	Margin (dB)	Remark
8760.000	31.37	15.57	46.94	74.00	-27.06	Peak
10480.000	31.89	17.57	49.46	74.00	-24.54	Peak
10480.000	21.72	17.57	39.29	54.00	-14.71	AVG
15720.000	32.32	21.22	53.54	74.00	-20.46	Peak
15720.000	20.65	21.22	41.87	54.00	-12.13	AVG

Remark:

1. Measuring frequencies from 1 GHz to the 10th harmonic of highest fundamental frequency.
2. For above 1GHz, the EUT peak value was under average limit, therefore the Average value compliance with the average limit

Test Mode	IEEE 802.11a High CH	Temp/Hum	27(°C)/ 53%RH
Test Item	Harmonic	Test Date	Jan 18, 2017
Polarize	Horizontal	Test Engineer	Kevin Kuo
Detector	Peak and Average	Test Voltage	120Vac / 60Hz

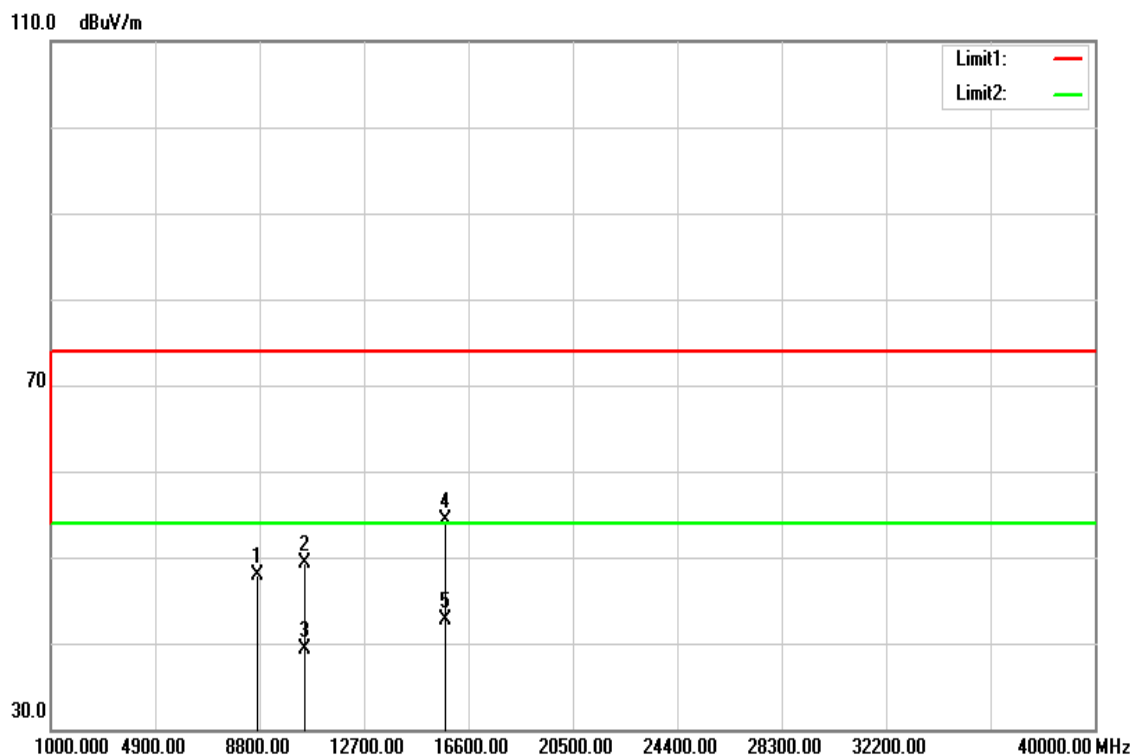

Frequency (MHz)	Reading (dBuV)	Correct Factor (dB/m)	Result (dBuV/m)	Limit (dBuV/m)	Margin (dB)	Remark
8720.000	32.48	15.49	47.97	74.00	-26.03	Peak
10480.000	31.73	17.57	49.30	74.00	-24.70	Peak
10480.000	21.80	17.57	39.37	54.00	-14.63	AVG
15720.000	32.99	21.22	54.21	74.00	-19.79	Peak
15720.000	21.41	21.22	42.63	54.00	-11.37	AVG

Remark:

1. Measuring frequencies from 1 GHz to the 10th harmonic of highest fundamental frequency.
2. For above 1GHz, the EUT peak value was under average limit, therefore the Average value compliance with the average limit

Test Mode	IEEE 802.11n HT20 Low CH	Temp/Hum	27(°C)/ 53%RH
Test Item	Harmonic	Test Date	Jan 18, 2017
Polarize	Vertical	Test Engineer	Kevin Kuo
Detector	Peak and Average	Test Voltage	120Vac / 60Hz

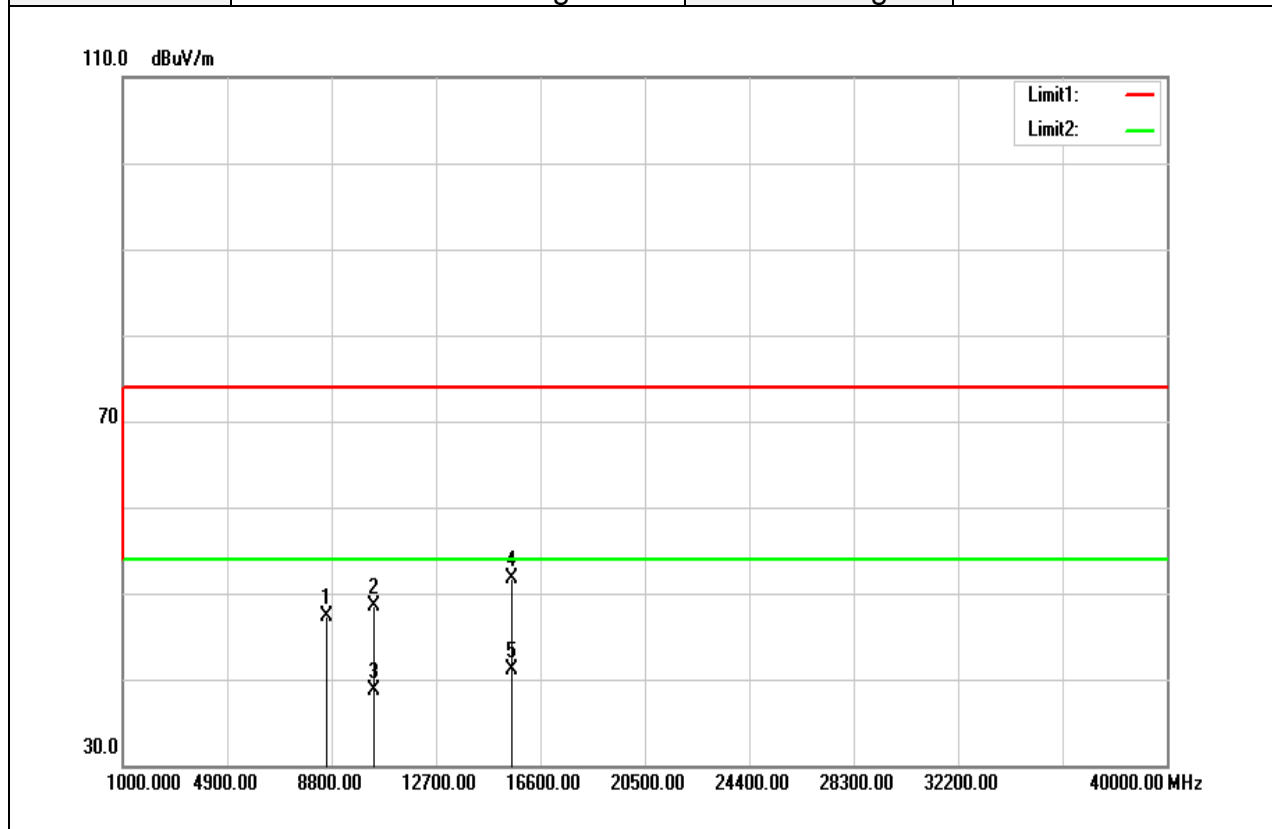

Frequency (MHz)	Reading (dBuV)	Correct Factor (dB/m)	Result (dBuV/m)	Limit (dBuV/m)	Margin (dB)	Remark
8620.000	31.96	15.31	47.27	74.00	-26.73	Peak
10360.000	30.99	17.58	48.57	74.00	-25.43	Peak
10360.000	21.15	17.58	38.73	54.00	-15.27	AVG
15540.000	31.11	20.61	51.72	74.00	-22.28	Peak
15540.000	20.57	20.61	41.18	54.00	-12.82	AVG

Remark:

1. Measuring frequencies from 1 GHz to the 10th harmonic of highest fundamental frequency.
2. For above 1GHz, the EUT peak value was under average limit, therefore the Average value compliance with the average limit

Test Mode	IEEE 802.11n HT20 Low CH	Temp/Hum	27(°C)/ 53%RH
Test Item	Harmonic	Test Date	Jan 18, 2017
Polarize	Horizontal	Test Engineer	Kevin Kuo
Detector	Peak and Average	Test Voltage	120Vac / 60Hz

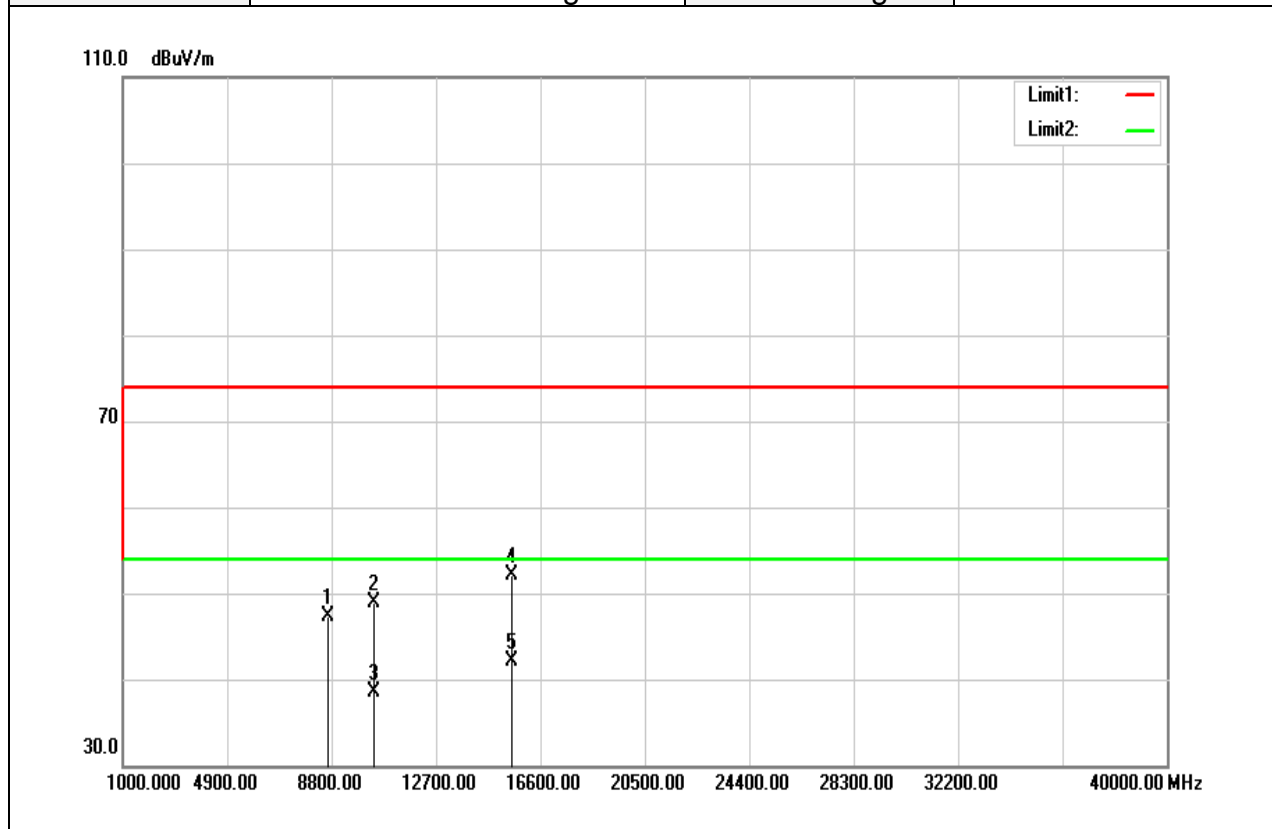

Frequency (MHz)	Reading (dBuV)	Correct Factor (dB/m)	Result (dBuV/m)	Limit (dBuV/m)	Margin (dB)	Remark
8660.000	31.85	15.38	47.23	74.00	-26.77	Peak
10360.000	31.23	17.58	48.81	74.00	-25.19	Peak
10360.000	20.88	17.58	38.46	54.00	-15.54	AVG
15540.000	31.48	20.61	52.09	74.00	-21.91	Peak
15540.000	21.47	20.61	42.08	54.00	-11.92	AVG

Remark:

1. Measuring frequencies from 1 GHz to the 10th harmonic of highest fundamental frequency.
2. For above 1GHz, the EUT peak value was under average limit, therefore the Average value compliance with the average limit

Test Mode	IEEE 802.11n HT20 Mid CH	Temp/Hum	27(°C)/ 53%RH
Test Item	Harmonic	Test Date	Jan 18, 2017
Polarize	Vertical	Test Engineer	Kevin Kuo
Detector	Peak and Average	Test Voltage	120Vac / 60Hz

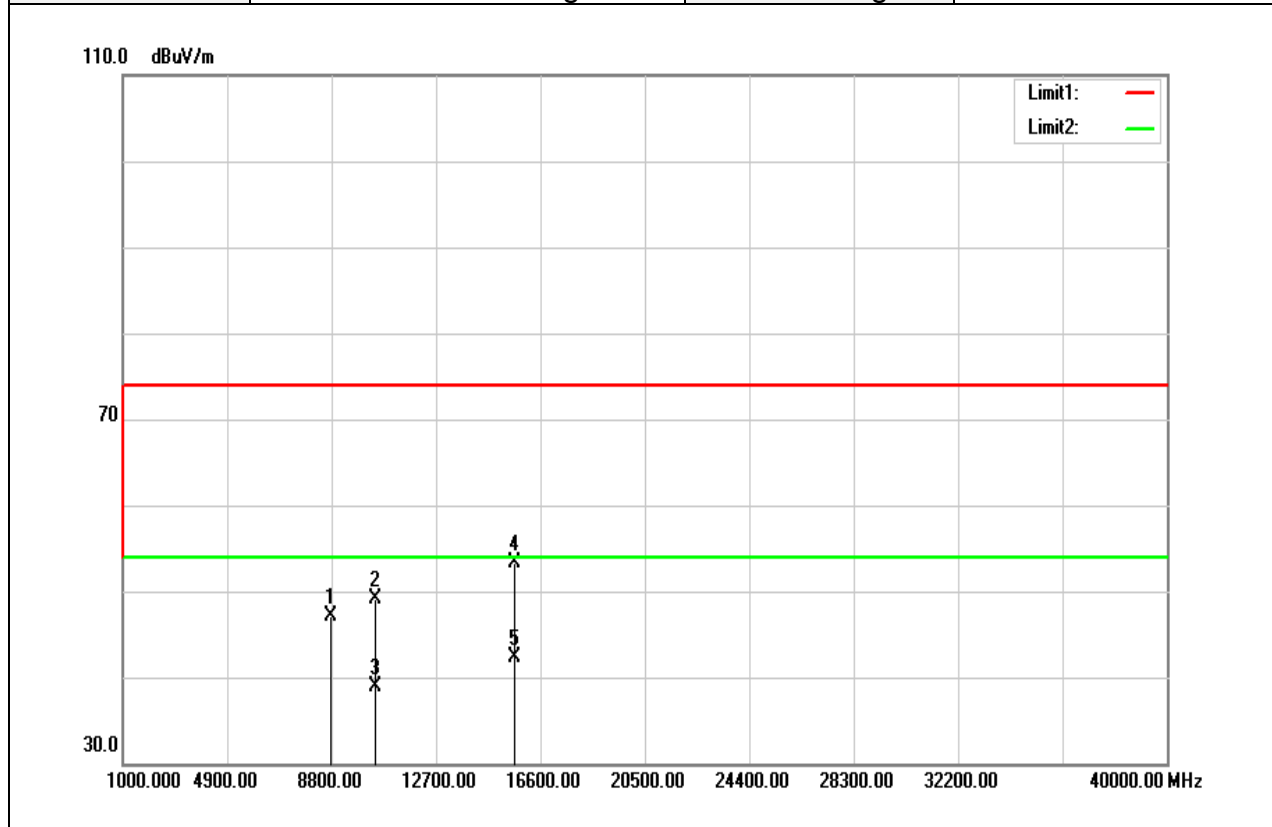

Frequency (MHz)	Reading (dBuV)	Correct Factor (dB/m)	Result (dBuV/m)	Limit (dBuV/m)	Margin (dB)	Remark
8770.000	31.53	15.59	47.12	74.00	-26.88	Peak
10440.000	31.47	17.57	49.04	74.00	-24.96	Peak
10440.000	21.35	17.57	38.92	54.00	-15.08	AVG
15660.000	32.19	21.02	53.21	74.00	-20.79	Peak
15660.000	21.30	21.02	42.32	54.00	-11.68	AVG

Remark:

1. Measuring frequencies from 1 GHz to the 10th harmonic of highest fundamental frequency.
2. For above 1GHz, the EUT peak value was under average limit, therefore the Average value compliance with the average limit

Test Mode	IEEE 802.11n HT20 Mid CH	Temp/Hum	27(°C)/ 53%RH
Test Item	Harmonic	Test Date	Jan 18, 2017
Polarize	Horizontal	Test Engineer	Kevin Kuo
Detector	Peak and Average	Test Voltage	120Vac / 60Hz

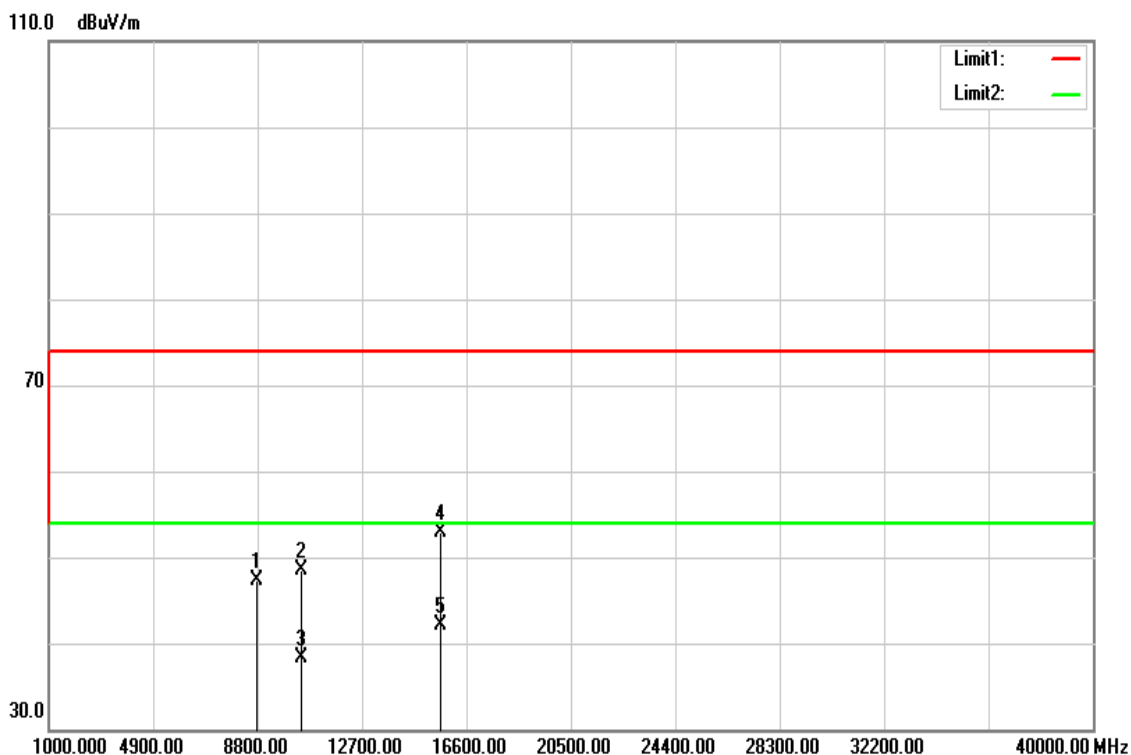

Frequency (MHz)	Reading (dBuV)	Correct Factor (dB/m)	Result (dBuV/m)	Limit (dBuV/m)	Margin (dB)	Remark
8750.000	31.67	15.55	47.22	74.00	-26.78	Peak
10440.000	30.95	17.57	48.52	74.00	-25.48	Peak
10440.000	20.73	17.57	38.30	54.00	-15.70	AVG
15660.000	31.98	21.02	53.00	74.00	-21.00	Peak
15660.000	21.09	21.02	42.11	54.00	-11.89	AVG

Remark:

1. Measuring frequencies from 1 GHz to the 10th harmonic of highest fundamental frequency.
2. For above 1GHz, the EUT peak value was under average limit, therefore the Average value compliance with the average limit

Test Mode	IEEE 802.11n HT20 High CH	Temp/Hum	27(°C)/ 53%RH
Test Item	Harmonic	Test Date	Jan 18, 2017
Polarize	Vertical	Test Engineer	Kevin Kuo
Detector	Peak and Average	Test Voltage	120Vac / 60Hz

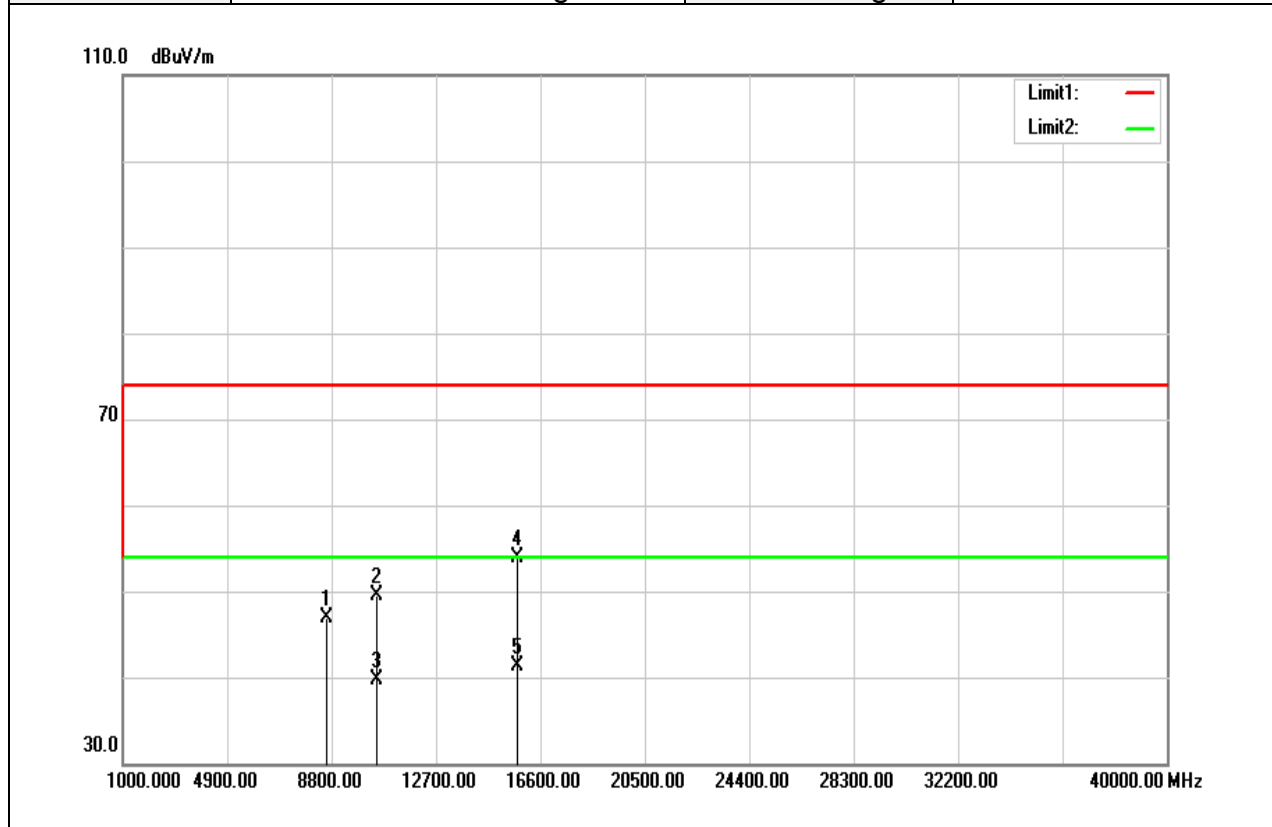

Frequency (MHz)	Reading (dBuV)	Correct Factor (dB/m)	Result (dBuV/m)	Limit (dBuV/m)	Margin (dB)	Remark
8630.000	31.67	15.32	46.99	74.00	-27.01	Peak
10480.000	31.91	17.57	49.48	74.00	-24.52	Peak
10480.000	22.15	17.57	39.72	54.00	-14.28	AVG
15720.000	32.60	21.22	53.82	74.00	-20.18	Peak
15720.000	20.17	21.22	41.39	54.00	-12.61	AVG

Remark:

1. Measuring frequencies from 1 GHz to the 10th harmonic of highest fundamental frequency.
2. For above 1GHz, the EUT peak value was under average limit, therefore the Average value compliance with the average limit

Test Mode	IEEE 802.11n HT20 High CH	Temp/Hum	27(°C)/ 53%RH
Test Item	Harmonic	Test Date	Jan 18, 2017
Polarize	Horizontal	Test Engineer	Kevin Kuo
Detector	Peak and Average	Test Voltage	120Vac / 60Hz

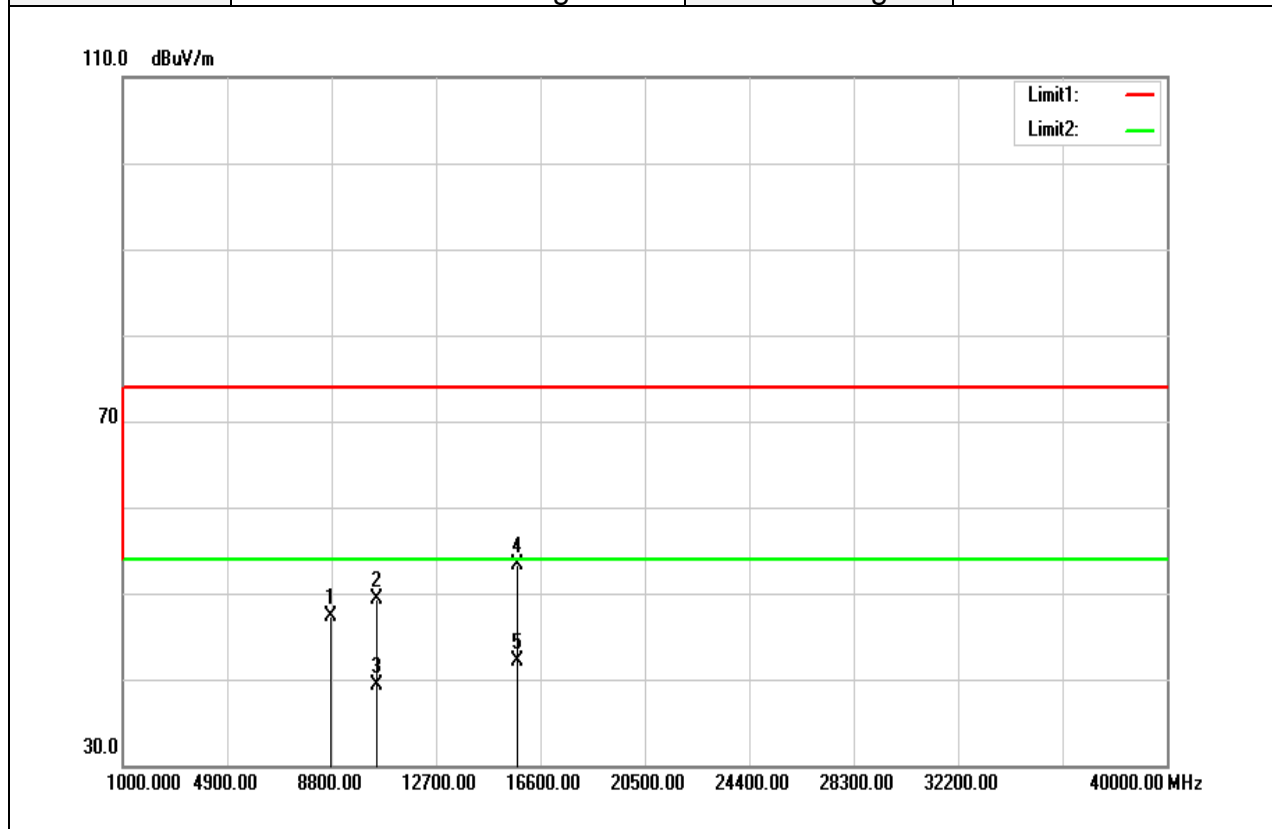

Frequency (MHz)	Reading (dBuV)	Correct Factor (dB/m)	Result (dBuV/m)	Limit (dBuV/m)	Margin (dB)	Remark
8750.000	31.71	15.55	47.26	74.00	-26.74	Peak
10480.000	31.66	17.57	49.23	74.00	-24.77	Peak
10480.000	21.71	17.57	39.28	54.00	-14.72	AVG
15720.000	32.00	21.22	53.22	74.00	-20.78	Peak
15720.000	20.85	21.22	42.07	54.00	-11.93	AVG

Remark:

1. Measuring frequencies from 1 GHz to the 10th harmonic of highest fundamental frequency.
2. For above 1GHz, the EUT peak value was under average limit, therefore the Average value compliance with the average limit

Test Mode	IEEE 802.11n HT40 Low CH	Temp/Hum	27(°C)/ 53%RH
Test Item	Harmonic	Test Date	Jan 18, 2017
Polarize	Vertical	Test Engineer	Kevin Kuo
Detector	Peak and Average	Test Voltage	120Vac / 60Hz

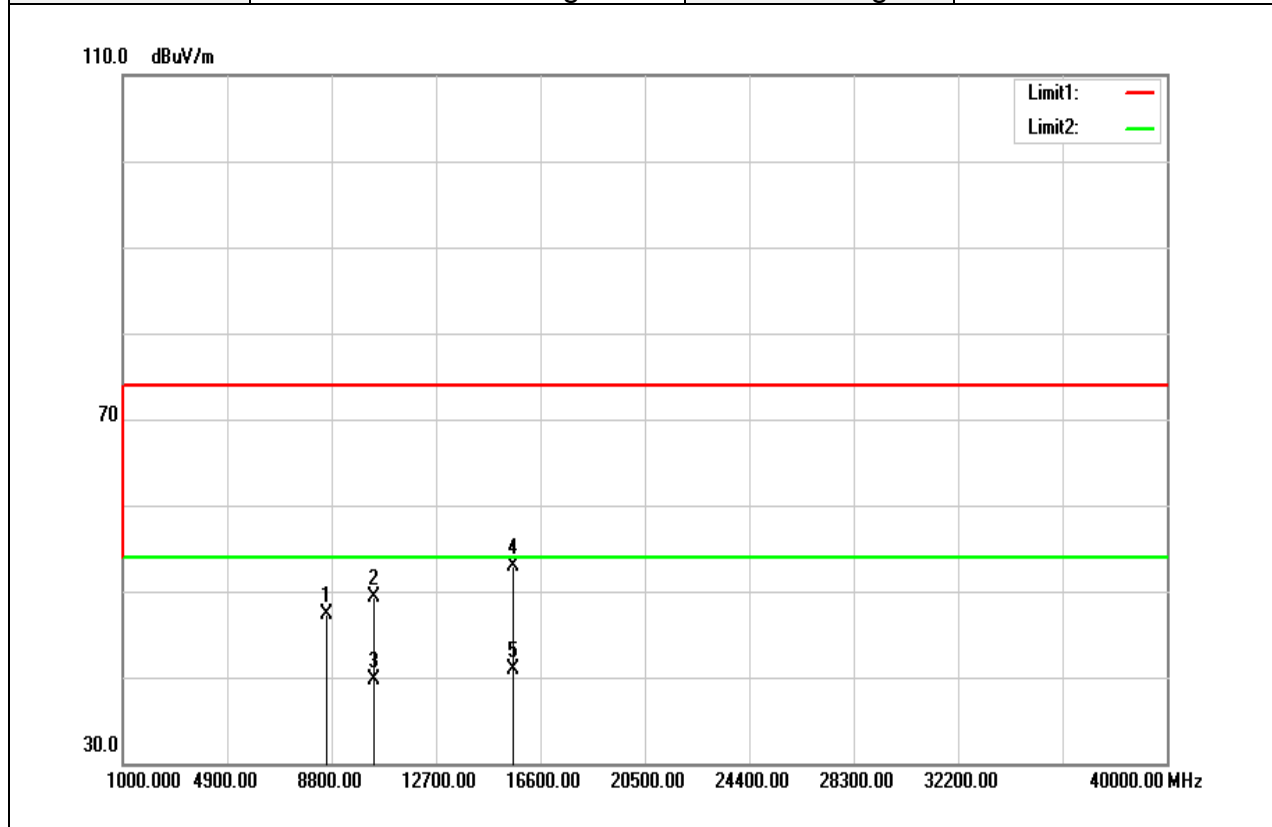

Frequency (MHz)	Reading (dBuV)	Correct Factor (dB/m)	Result (dBuV/m)	Limit (dBuV/m)	Margin (dB)	Remark
8630.000	32.07	15.32	47.39	74.00	-26.61	Peak
10380.000	31.78	17.58	49.36	74.00	-24.64	Peak
10380.000	22.03	17.58	39.61	54.00	-14.39	AVG
15570.000	32.13	20.71	52.84	74.00	-21.16	Peak
15570.000	20.16	20.71	40.87	54.00	-13.13	AVG

Remark:

1. Measuring frequencies from 1 GHz to the 10th harmonic of highest fundamental frequency.
2. For above 1GHz, the EUT peak value was under average limit, therefore the Average value compliance with the average limit

Test Mode	IEEE 802.11n HT40 Low CH	Temp/Hum	27(°C)/ 53%RH
Test Item	Harmonic	Test Date	Jan 18, 2017
Polarize	Horizontal	Test Engineer	Kevin Kuo
Detector	Peak and Average	Test Voltage	120Vac / 60Hz

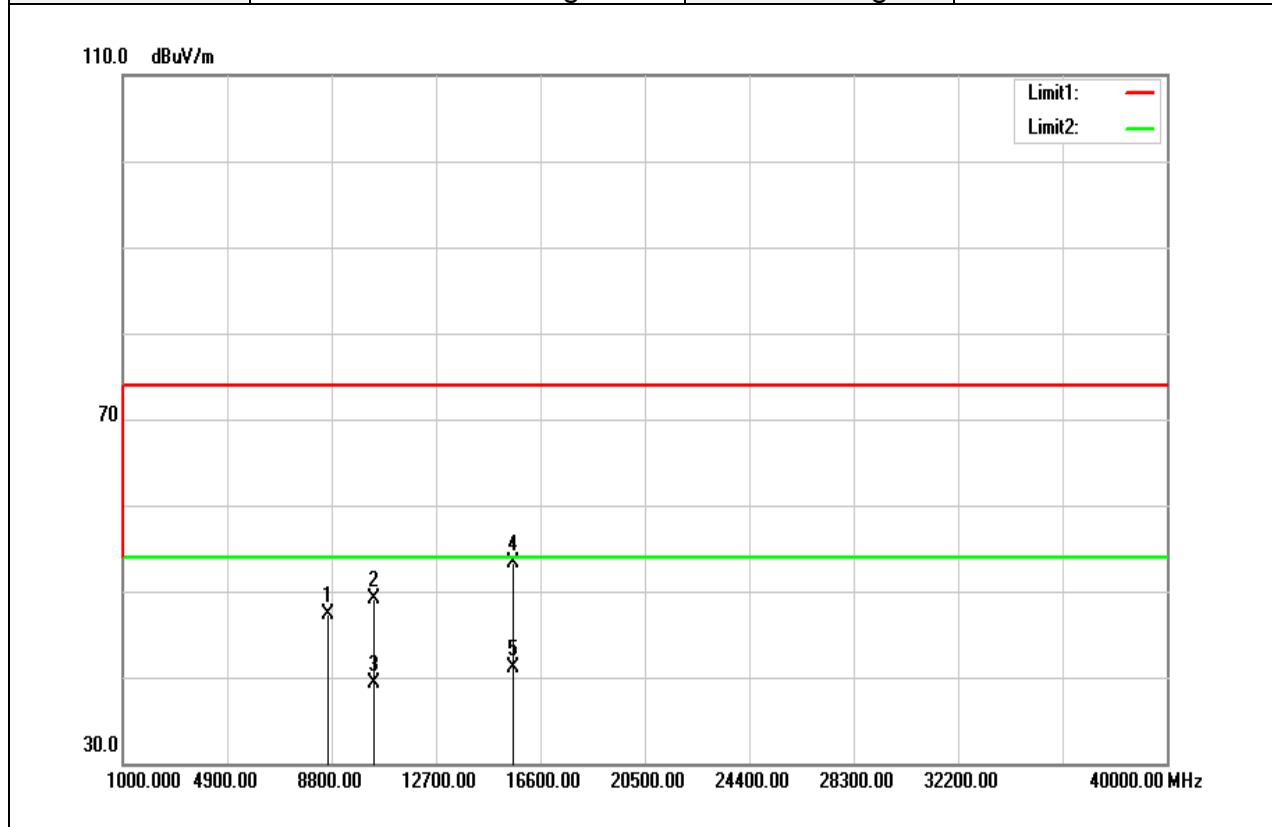

Frequency (MHz)	Reading (dBuV)	Correct Factor (dB/m)	Result (dBuV/m)	Limit (dBuV/m)	Margin (dB)	Remark
8650.000	31.87	15.36	47.23	74.00	-26.77	Peak
10380.000	31.44	17.58	49.02	74.00	-24.98	Peak
10380.000	21.79	17.58	39.37	54.00	-14.63	AVG
15570.000	32.60	20.71	53.31	74.00	-20.69	Peak
15570.000	20.48	20.71	41.19	54.00	-12.81	AVG

Remark:

1. Measuring frequencies from 1 GHz to the 10th harmonic of highest fundamental frequency.
2. For above 1GHz, the EUT peak value was under average limit, therefore the Average value compliance with the average limit

Test Mode	IEEE 802.11n HT40 High CH	Temp/Hum	27(°C)/ 53%RH
Test Item	Harmonic	Test Date	Jan 18, 2017
Polarize	Vertical	Test Engineer	Kevin Kuo
Detector	Peak and Average	Test Voltage	120Vac / 60Hz

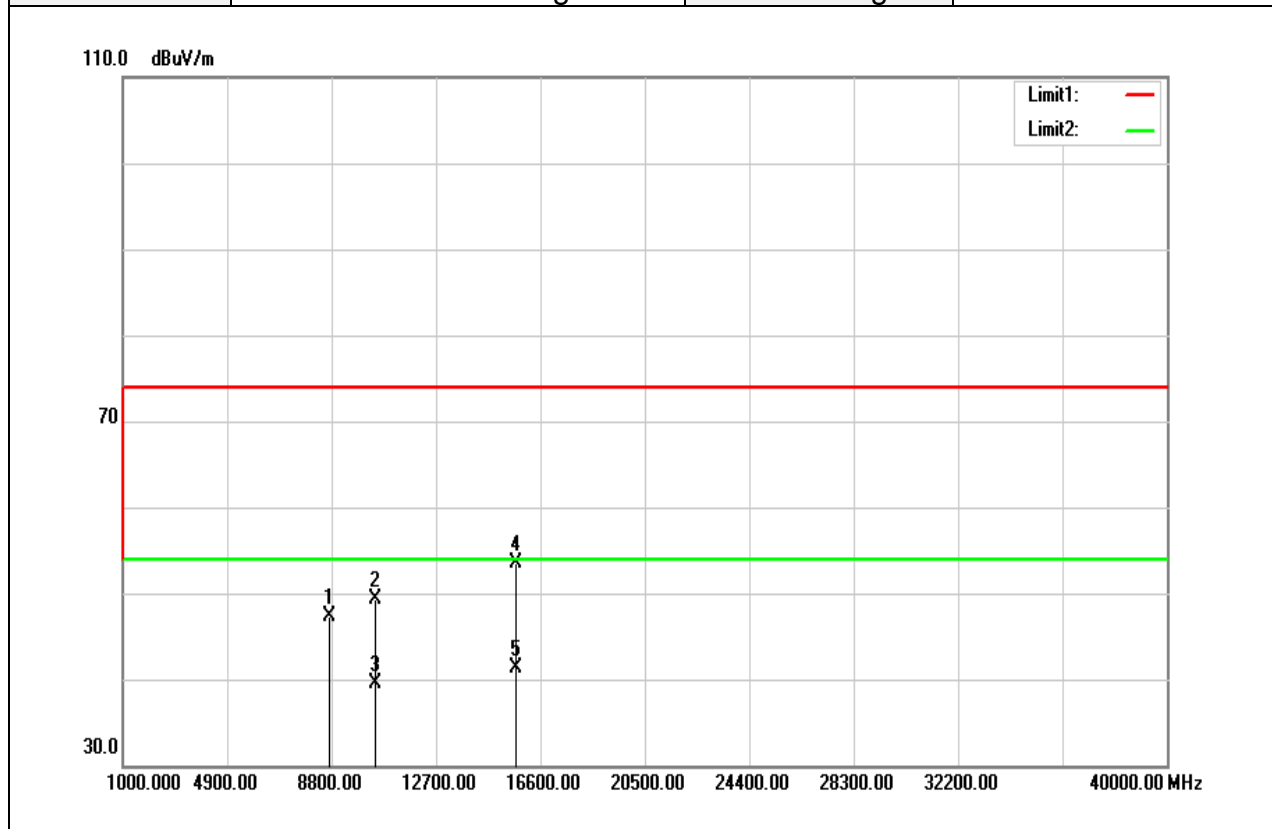

Frequency (MHz)	Reading (dBuV)	Correct Factor (dB/m)	Result (dBuV/m)	Limit (dBuV/m)	Margin (dB)	Remark
8740.000	31.85	15.53	47.38	74.00	-26.62	Peak
10460.000	31.66	17.57	49.23	74.00	-24.77	Peak
10460.000	21.97	17.57	39.54	54.00	-14.46	AVG
15690.000	32.39	21.12	53.51	74.00	-20.49	Peak
15690.000	20.16	21.12	41.28	54.00	-12.72	AVG

Remark:

1. Measuring frequencies from 1 GHz to the 10th harmonic of highest fundamental frequency.
2. For above 1GHz, the EUT peak value was under average limit, therefore the Average value compliance with the average limit

Test Mode	IEEE 802.11n HT40 High CH	Temp/Hum	27(°C)/ 53%RH
Test Item	Harmonic	Test Date	Jan 18, 2017
Polarize	Horizontal	Test Engineer	Kevin Kuo
Detector	Peak and Average	Test Voltage	120Vac / 60Hz

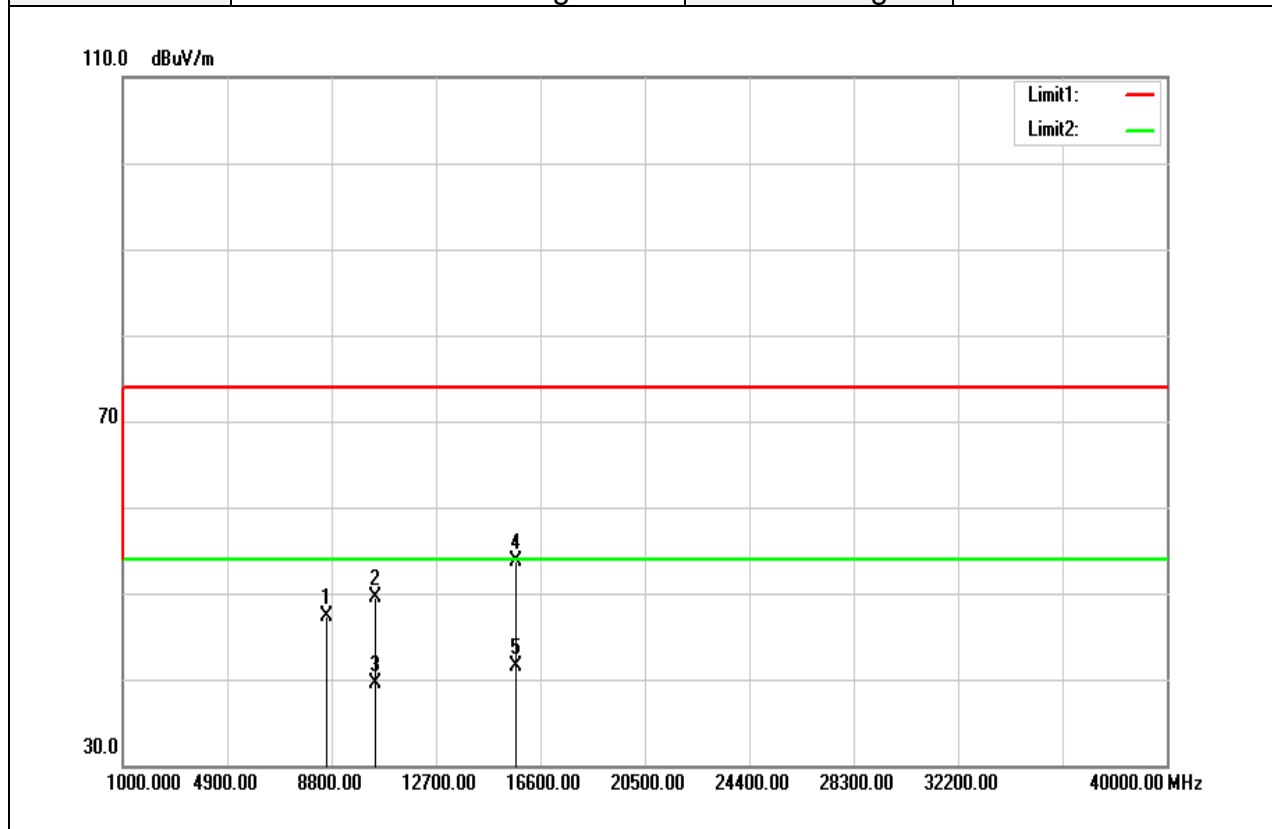

Frequency (MHz)	Reading (dBuV)	Correct Factor (dB/m)	Result (dBuV/m)	Limit (dBuV/m)	Margin (dB)	Remark
8610.000	32.10	15.29	47.39	74.00	-26.61	Peak
10460.000	31.90	17.57	49.47	74.00	-24.53	Peak
10460.000	21.86	17.57	39.43	54.00	-14.57	AVG
15690.000	32.62	21.12	53.74	74.00	-20.26	Peak
15690.000	20.35	21.12	41.47	54.00	-12.53	AVG

Remark:

1. Measuring frequencies from 1 GHz to the 10th harmonic of highest fundamental frequency.
2. For above 1GHz, the EUT peak value was under average limit, therefore the Average value compliance with the average limit

4.6 FREQUENCY STABILITY

4.6.1 Test Limit

According to §15.407(g) manufacturers of U-NII devices are responsible for ensuring frequency stability such that an emission is maintained within the band of operation under all conditions of normal operation as specified in the operational description.

4.6.2 Test Procedure

The equipment under test was connected to an external AC or DC power supply and input rated voltage. RF output was connected to a frequency counter or spectrum analyzer via feed through attenuators. The EUT was placed inside the temperature chamber. Set the spectrum analyzer RBW low enough to obtain the desired frequency resolution and measure EUT 20°C operating frequency as reference frequency. Turn EUT off and set the chamber temperature to -20°C. After the temperature stabilized for approximately 30 minutes recorded the frequency. Repeat step measure with 10°C increased per stage until the highest temperature of +50°C reached.

4.6.3 Test Setup

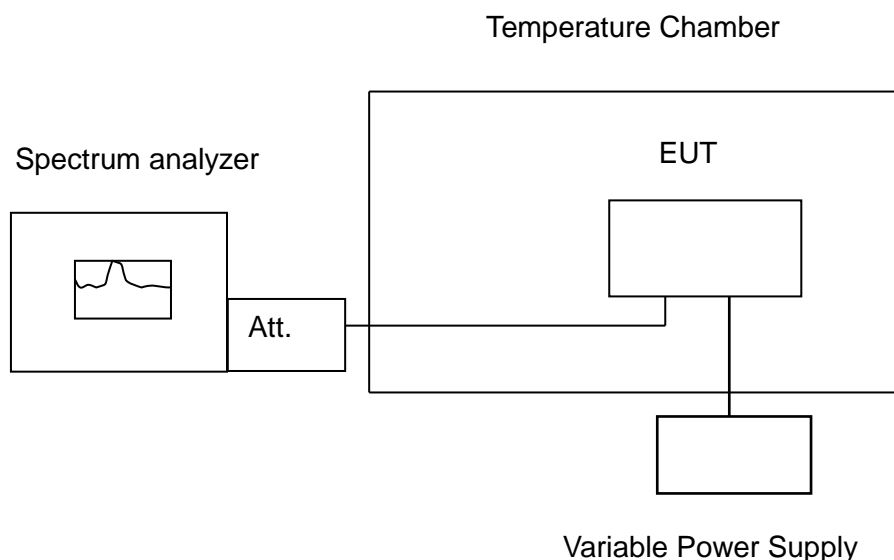

4.6.4 Test Result

Temperature Variations for UNII-1

Temp. (°C)	Voltage (V)	Measured Frequency	5180				Limit				Result
			Time (min)				20ppm				
Operating Frequency:		0 min	2 min	5 min	10 min	0 min	2 min	5 min	10 min		
50	3.7	5220.0473	5220.0482	5220.0517	5220.0508	9.0651	9.7318	9.8966	9.2318	Pass	
40	3.7	5220.0104	5220.0096	5220.0096	5220.0078	1.9962	1.4962	1.8295	1.8295	Pass	
30	3.7	5220.0488	5220.0471	5220.0395	5220.0390	9.3391	9.0307	7.5632	7.4617	Pass	
20	3.7	5219.9919	5219.9922	5219.9937	5219.9943	-1.5536	-1.5000	-1.2088	-1.0977	Pass	
10	3.7	5219.9955	5219.9968	5219.9975	5219.9981	-0.8659	-0.6092	-0.4713	-0.3602	Pass	
0	3.7	5220.0456	5220.0468	5220.0474	5220.0487	8.7356	8.9732	9.0709	9.3372	Pass	
-10	3.7	5220.0492	5220.0489	5220.0474	5220.0465	9.4157	9.3697	9.0843	8.9138	Pass	
-20	3.7	5220.0463	5220.0477	5220.0486	5220.0499	8.8697	9.1284	9.3161	9.5498	Pass	

Temp. (°C)	Voltage (V)	Measured Frequency	5180				Limit				Result
			Time (min)				20ppm				
Operating Frequency:		0 min	2 min	5 min	10 min	0 min	2 min	5 min	10 min		
20	3.33	5219.9908	5219.9916	5219.9926	5219.9939	-1.7663	-1.6130	-1.4253	-1.1762	Pass	
20	3.7	5219.9919	5219.9922	5219.9937	5219.9943	-1.5536	-1.5000	-1.2088	-1.0977	Pass	
20	4.07	5219.9925	5219.9935	5219.9945	5219.9958	-1.4291	-1.2433	-1.0575	-0.8084	Pass	