

---

# RADIO TEST REPORT

## FCC 47 CFR PART 15 SUBPART C

### INDUSTRY CANADA RSS-247

<b>Test Standard</b>	<b>FCC Part 15.247 and RSS-247 Issue 2</b>
<b>FCC ID</b>	<b>A4C-1000DA</b>
<b>ISED No.</b>	<b>10199A-1000DA</b>
<b>Trade name</b>	<b>Rand McNally</b>
<b>Product name</b>	<b>OverDryve™ 8Pro</b>
<b>Model No.</b>	<b>OD8</b>
<b>Test Result</b>	<b>Pass</b>

The test Result was tested by Compliance Certification Services Inc. The test data, data evaluation, test procedures, and equipment configurations shown in this report were given in ANSI C63.10: 2013 and compliance standards.

The test results of this report relate only to the tested sample (EUT) identified in this report.

The test Report of full or partial shall not copy. Without written approval of Compliance Certification Services Inc. (Hsinchu Lab)

The sample selected for test was production product and was provided by manufacturer.



Approved by:

Reviewed by:

Handwritten signature of Davis Tseng in blue ink.

Handwritten signature of Zeus Chen in black ink.

---

Davis Tseng  
Sr. Engineer

---

Zeus Chen  
Supervisor

## Revision History

Rev.	Issue Date	Revisions	Revised By
00	January 25, 2017	Initial Issue	Angel Cheng
01	March 27, 2017	1. Add Test Setup Photos in page 42, 43.	Doris Chu
02	March 28, 2017	1. Modify Antenna Category & Antenna Type in page 5.	Angel Cheng
03	March 30, 2017	1. Remove remark in page 4. 2. Revise section 4.2.2 in page 16.	Angel Cheng
04	April 13, 2017	1. Update the test result sections in page 16, 18, 20.	Angel Cheng

## Table of contents

<b>1. GENERAL INFORMATION .....</b>	<b>4</b>
<b>1.1 EUT INFORMATION .....</b>	<b>4</b>
<b>1.2 EUT CHANNEL INFORMATION .....</b>	<b>5</b>
<b>1.3 ANTENNA INFORMATION .....</b>	<b>5</b>
<b>1.4 MEASUREMENT UNCERTAINTY.....</b>	<b>6</b>
<b>1.5 FACILITIES AND TEST LOCATION .....</b>	<b>7</b>
<b>1.6 INSTRUMENT CALIBRATION .....</b>	<b>7</b>
<b>1.7 SUPPORT AND EUT ACCESSORIES EQUIPMENT .....</b>	<b>8</b>
<b>2. TEST SUMMERY .....</b>	<b>9</b>
<b>3. DESCRIPTION OF TEST MODES .....</b>	<b>10</b>
<b>3.1 THE WORST MODE OF OPERATING CONDITION .....</b>	<b>10</b>
<b>3.2 THE WORST MODE OF MEASUREMENT .....</b>	<b>11</b>
<b>3.3 EUT DUTY CYCLE.....</b>	<b>12</b>
<b>4. TEST RESULT .....</b>	<b>13</b>
<b>4.1 AC POWER LINE CONDUCTED EMISSION .....</b>	<b>13</b>
<b>4.2 6DB BANDWIDTH AND OCCUPIED BANDWIDTH(99%) .....</b>	<b>16</b>
<b>4.3 OUTPUT POWER MEASUREMENT .....</b>	<b>18</b>
<b>4.4 POWER SPECTRAL DENSITY.....</b>	<b>20</b>
<b>4.5 CONDUCTED BAND EDGE AND SPURIOUS EMISSION .....</b>	<b>22</b>
<b>4.6 RADIATION BANDEDGE AND SPURIOUS EMISSION .....</b>	<b>26</b>
<b>APPENDIX 1 - PHOTOGRAPHS OF EUT</b>	

# 1. GENERAL INFORMATION

## 1.1 EUT INFORMATION

Applicant	RM Acquisition, LLC 9855 Woods Drive Skokie, IL 60077 USA.
Equipment	OverDryve™ 8Pro
Model Name	OD8
Model Discrepancy	N/A
EUT Functions	IEEE 802.11 abgn+BT+GPS+FM
Received Date	Dec 22, 2016
Date of Test	Jan 03, 2017 ~ Jan 19, 2017
Output Power (W)	BLE : 0.0039 (EIRP : 0.0045)
Power Operation	<input checked="" type="checkbox"/> Adapter Model: W12-010N3A I/P: 100-240V, 50/60Hz, 0.3A O/P: 5V, 2A <input checked="" type="checkbox"/> Host system <input checked="" type="checkbox"/> DC Type : <input checked="" type="checkbox"/> Battery <input checked="" type="checkbox"/> Car Charger <input type="checkbox"/> DC Power Supply

## 1.2 EUT CHANNEL INFORMATION

Frequency Range	2402MHz-2480MHz
Modulation Type	GFSK for BLE-1Mbps
Number of channel	40 Channels

**Remark:**

Refer as ANSI 63.10:2013 clause 5.6.1 Table 4 and RSS-GEN Table A1 for test channels

Number of frequencies to be tested		
Frequency range in which device operates	Number of frequencies	Location in frequency range of operation
<input type="checkbox"/> 1 MHz or less	1	Middle
<input type="checkbox"/> 1 MHz to 10 MHz	2	1 near top and 1 near bottom
<input checked="" type="checkbox"/> More than 10 MHz	3	1 near top, 1 near middle, and 1 near bottom

## 1.3 ANTENNA INFORMATION

<b>Antenna Category</b>	<input type="checkbox"/> Integral: antenna permanently attached <input type="checkbox"/> External dedicated antennas <input checked="" type="checkbox"/> External Unique antenna connector
<b>Antenna Type</b>	<input type="checkbox"/> PIFA <input checked="" type="checkbox"/> PCB <input type="checkbox"/> Dipole <input type="checkbox"/> Coils
<b>Antenna Gain</b>	0.63 dBi

## 1.4 MEASUREMENT UNCERTAINTY

PARAMETER	UNCERTAINTY
AC Powerline Conducted Emission	+/- 1.2575
Emission bandwidth, 20dB bandwidth	+/- 1.4003
RF output power, conducted	+/- 1.1372
Power density, conducted	+/- 1.4003
3M Semi Anechoic Chamber / 30M~200M	+/- 4.0138
3M Semi Anechoic Chamber / 200M~1000M	+/- 3.9483
3M Semi Anechoic Chamber / 1G~8G	+/- 2.5975
3M Semi Anechoic Chamber / 8G~18G	+/- 2.6112
3M Semi Anechoic Chamber / 18G~26G	+/- 2.7389
3M Semi Anechoic Chamber / 26G~40G	+/- 2.9683
3M Semi Anechoic Chamber / 40G~60G	+/- 1.8509
3M Semi Anechoic Chamber / 60G~75G	+/- 1.9869
3M Semi Anechoic Chamber / 75G~110G	+/- 2.9651
3M Semi Anechoic Chamber / 110G~170G	+/- 2.7807
3M Semi Anechoic Chamber / 170G~220G	+/- 3.6437
3M Semi Anechoic Chamber / 220G~325G	+/- 4.2982

**Remark:**

1. This uncertainty represents an expanded uncertainty expressed at approximately the 95% confidence level using a coverage factor of  $k=2$
2. ISO/IEC 17025 requires that an estimate of the measurement uncertainties associated with the emissions test results be included in the report.

## 1.5 FACILITIES AND TEST LOCATION

All measurement facilities used to collect the measurement data are located at  
 No.11, Wugong 6th Rd., Wugu Dist., New Taipei City 24891, Taiwan. (R.O.C.)

Test site	Test Engineer	Remark
AC Conduction Room	Jim Lian	
Radiation	Ed Chiang	
RF Conducted	Eric Lee	

**Remark:** The sites are constructed in conformance with the requirements of ANSI C63.7, ANSI C63.4 and CISPR Publication 22.

## 1.6 INSTRUMENT CALIBRATION

RF Conducted Test Site					
Equipment	Manufacturer	Model	S/N	Cal Date	Cal Due
Spectrum Analyzer	R&S	FSV 40	101073	08/01/2017	07/31/2017

3M 966 Chamber Test Site					
Equipment	Manufacturer	Model	S/N	Cal Due	Cal Due
Bi-log Antenna	TESEQ	CBL 6112D	35403	07/03/2016	07/02/2017
Double Ridged BroadBand Horn Antenna	SCHWARZBECK	BBHA 9120 D	9120D-778	07/15/2016	07/14/2017
Double Ridged Guide Horn Antenna	ETS · LINDGREN	3117	00078733	11/17/2016	11/16/2017
EMI Test Receiver	ROHDE & SCHWARZ	ESCI	100221	04/27/2016	04/26/2017
Horn Antenna	COM-POWER	AH-840	03077	12/02/2016	12/01/2017
Loop Antenna	COM-POWER	AL-130	121060	05/24/2016	05/23/2017
Preamplifier	Agilent	8447D	2944A10052	07/13/2016	07/12/2017
Preamplifier	Agilent	8449B	3008A01916	07/13/2016	07/12/2017
PSA Series Spectrum Analyzer	Agilent	E4446A	MY46180323	04/13/2016	04/12/2017
Software	E3.815206a				

AC Conducted Emissions Test Site					
Equipment	Manufacturer	Model	S/N	Cal Date	Cal Due
EMI Test Receiver	R&S	ESCI	101201	08/20/2016	08/19/2017
LISN	Schwarzbeck	NNLK 8129	8129-286	08/19/2016	08/18/2017
LISN(EUT)	Schwarzbeck	NSLK 8127	8127-527	08/19/2016	08/18/2017
Pulse Limiter	R&S	ESH3Z2	C3010026-2	08/21/2016	08/22/2017
Software	EZ-EMC				

**Remark:** Each piece of equipment is scheduled for calibration once a year.

## 1.7 SUPPORT AND EUT ACCESSORIES EQUIPMENT



EUT Accessories Equipment					
No.	Equipment	Brand	Model	Series No.	FCC ID
1					

Support Equipment					
No.	Equipment	Brand	Model	Series No.	FCC ID
1	Earphone	INTOPIC	JASS-288	N/A	N/A
2	Monitor	ASUS	PA248Q	G5LMQS071275	N/A

## 1.8 Test methodology and applied standards

The test methodology, setups and results comply with all requirements in accordance with ANSI C63.10:2013, FCC Part 2, FCC Part 15.247, KDB 558074 D01 v03r05, RSS-247 Issue 2 and RSS-GEN Issue 4

## 1.9 Table of accreditations and listings

Country	Agency	Scope of Accreditation	Logo
USA	FCC	3M Semi Anechoic Chamber (FCC MRA: TW10279) to perform FCC Part 15 measurements	 FCC MRA: TW1027
Canada	Industry Canada	3M Semi Anechoic Chamber (IC 2324G-1 / IC 2324G-2) to perform	 IC 2324G-1 IC 2324G-2



## 2. TEST SUMMERY

FCC Standard Section	IC Standard Section	Report Section	Test Item	Result
15.203	-	1.2	Antenna Requirement	Pass
15.207(a)	RSS-GEN 8.8	4.1	AC Conducted Emission	Pass
15.247(a)(2)	RSS-247(5.2)(a)	4.2	6 dB Bandwidth	Pass
-	RSS-GEN 6.6	4.2	Occupied Bandwidth (99%)	Pass
15.247(b)	RSS-247(5.4)(d)	4.3	Output Power Measurement	Pass
15.247(e)	RSS-247(5.2)(b)	4.4	Power Spectral Density	Pass
15.247(d)	RSS-247(5.5)	4.5	Conducted Band Edge	Pass
15.247(d)	RSS-247(5.5)	4.5	Conducted Emission	Pass
15.247(d)	RSS-GEN 8.9, 8.10	4.6	Radiation Band Edge	Pass
15.247(d)	RSS-GEN 8.9, 8.10	4.6	Radiation Spurious Emission	Pass

### 3. DESCRIPTION OF TEST MODES

#### 3.1 THE WORST MODE OF OPERATING CONDITION

Operation mode	BT4.0 Mode (1Mbps)
Test Channel Frequencies	1.Lowest Channel : 2402MHz 2.Middle Channel : 2440MHz 3.Highest Channel : 2480MHz

*Remark:*

1. EUT pre-scanned data rate of output power for each mode, the worst data rate were recorded in this report.

.

### 3.2 THE WORST MODE OF MEASUREMENT

AC Power Line Conducted Emission	
Test Condition	AC Power line conducted emission for line and neutral
Voltage/Hz	120V/60Hz
Test Mode	Mode 1:EUT power by host system via USB Cable
Worst Mode	<input checked="" type="checkbox"/> Mode 1 <input type="checkbox"/> Mode 2 <input type="checkbox"/> Mode 3 <input type="checkbox"/> Mode 4

Radiated Emission Measurement Above 1G	
Test Condition	Band edge, Emission for Unwanted and Fundamental
Voltage/Hz	120V/60Hz
Test Mode	Mode 1:EUT power by Battery
Worst Mode	<input checked="" type="checkbox"/> Mode 1 <input type="checkbox"/> Mode 2 <input type="checkbox"/> Mode 3 <input type="checkbox"/> Mode 4
Worst Position	<input type="checkbox"/> Placed in fixed position. <input checked="" type="checkbox"/> Placed in fixed position at X-Plane (E2-Plane) <input type="checkbox"/> Placed in fixed position at Y-Plane (E1-Plane) <input type="checkbox"/> Placed in fixed position at Z-Plane (H-Plane)
Worst Polarity	<input checked="" type="checkbox"/> Horizontal <input type="checkbox"/> Vertical

Radiated Emission Measurement Below 1G	
Test Condition	Radiated Emission Below 1G
Voltage/Hz	120V/60Hz
Test Mode	Mode 1:EUT power by Battery
Worst Mode	<input checked="" type="checkbox"/> Mode 1 <input type="checkbox"/> Mode 2 <input type="checkbox"/> Mode 3 <input type="checkbox"/> Mode 4

*Remark:*

1. The worst mode was record in this test report.
2. EUT pre-scanned in three axis ,X ,Y, Z and two polarity, Horizontal and Vertical for radiated measurement. The worst case(X-Plane and Horizontal) were recorded in this report.
3. For below 1G AC power line conducted emission and radiation emission were performed the EUT transmit at the Maximum bandwidth and Middle channel as worse case.
4. EUT Transmit only can by Battery to set. Therefore EUT used Battery mode for Radiated measurement above 1G and Conduction below 1G in test report.

### 3.3 EUT DUTY CYCLE

Duty Cycle				
Configuration	TX ON (ms)	TX ALL (ms)	Duty Cycle (%)	Duty Factor(dB)
BLE	0.4493	0.6232	72.10	1.42

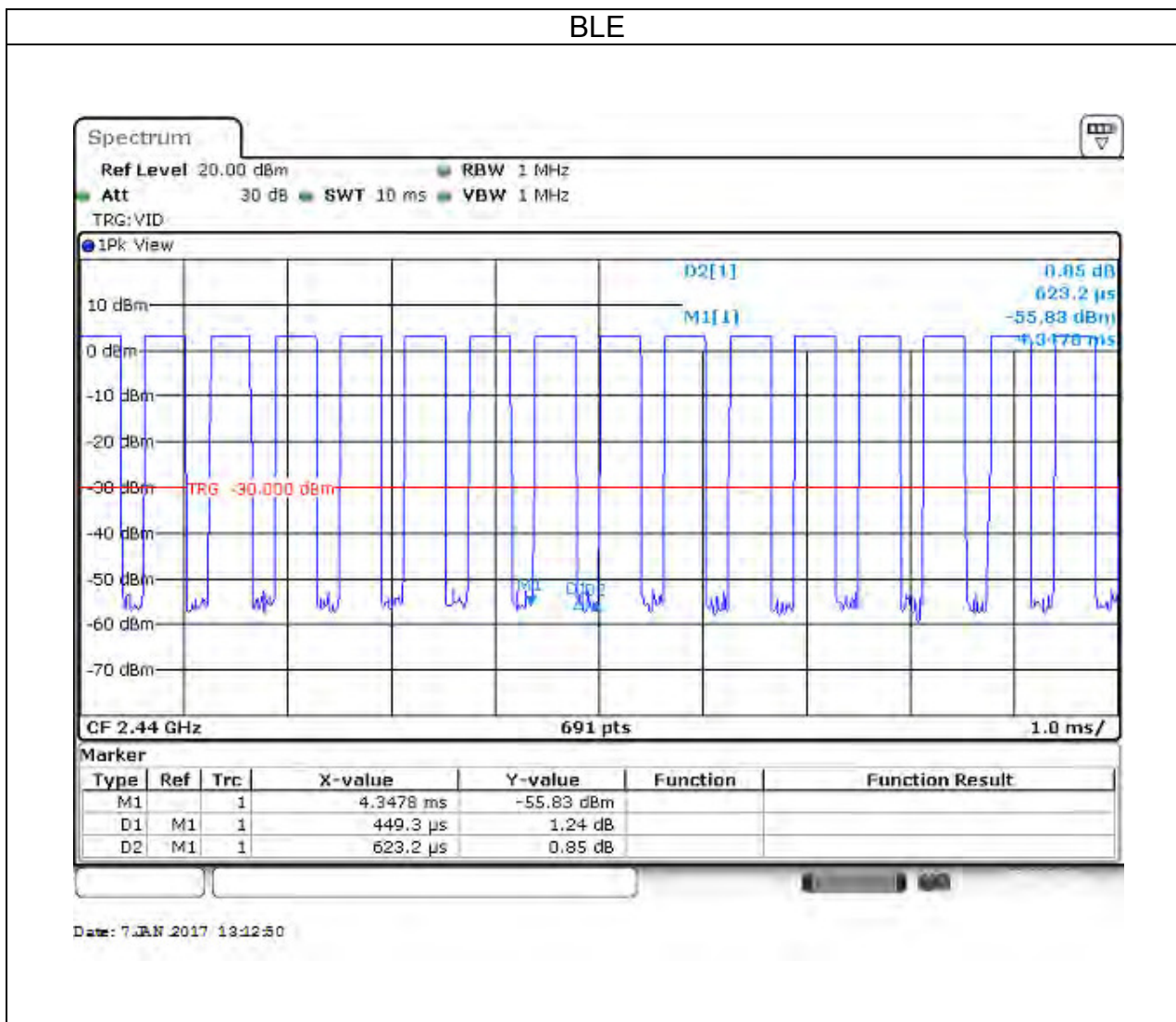

## 4. TEST RESULT

### 4.1 AC POWER LINE CONDUCTED EMISSION

#### 4.1.1 Test Limit

According to §15.207(a) and RSS-GEN section 8.8,

Frequency Range (MHz)	Limits(dBµV)	
	Quasi-peak	Average
0.15 to 0.50	66 to 56*	56 to 46*
0.50 to 5	56	46
5 to 30	60	50

\* Decreases with the logarithm of the frequency.

#### 4.1.2 Test Procedure

Test method Refer as ANSI 63.10:2013 clause 6.2,

1. The EUT was placed on a non-conducted table, which is 0.8m above horizontal ground plane and 0.4m above vertical ground plane.
2. EUT connected to the line impedance stabilization network (LISN)
3. Receiver set RBW of 9kHz and Detector Peak, and note as quasi-peak and average.
4. Maximum procedure was performed on the six highest emissions to ensure EUT compliance.
5. Recorded Line for Neutral and Line.

#### 4.1.3 Test Setup

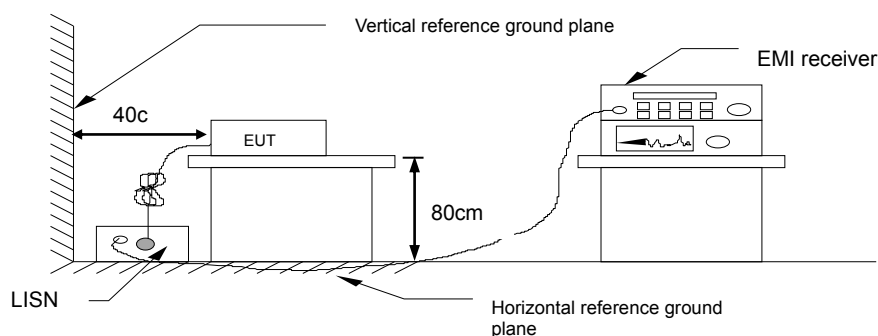

#### 4.1.4 Test Result

**Pass**

**Test Data**

Test Mode:	Mode 1	Temp/Hum	27(°C)/ 53%RH
Test Voltage:	120Vac / 60Hz	Test Date	Jan 03, 2017
Phase:	Line	Test Engineer	Jim Lian

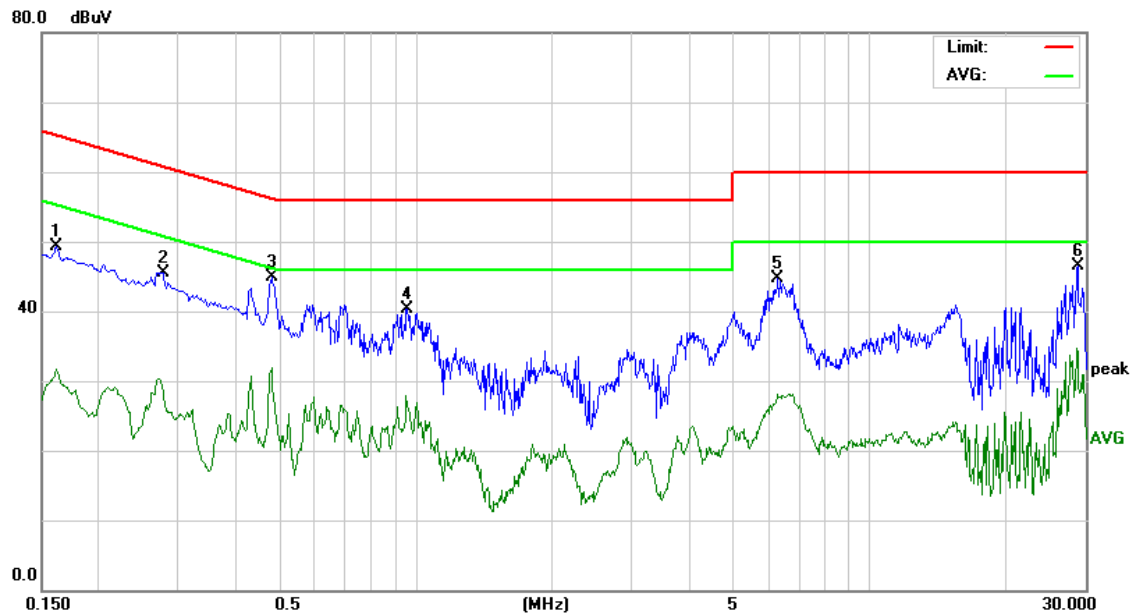

Frequency (MHz)	Reading (dBuV)	Factor (dB)	Result (dB)	Limit (dBuV)	Margin (dBuV)	Detector (dBuV)
0.16	39.26	9.97	49.23	65.36	-16.13	Peak
0.28	35.49	10.02	45.51	60.88	-15.37	Peak
0.48	34.90	10.03	44.93	56.30	-11.37	Peak
0.96	30.20	10.06	40.26	56.00	-15.74	Peak
6.29	34.40	10.32	44.72	60.00	-15.28	Peak
28.76	35.67	10.87	46.54	60.00	-13.46	Peak

Test Mode:	Mode 1	Temp/Hum	27(°C)/ 53%RH
Test Voltage:	120Vac / 60Hz	Test Date	Jan 03, 2017
Phase:	Neutral	Test Engineer	Jim Lian

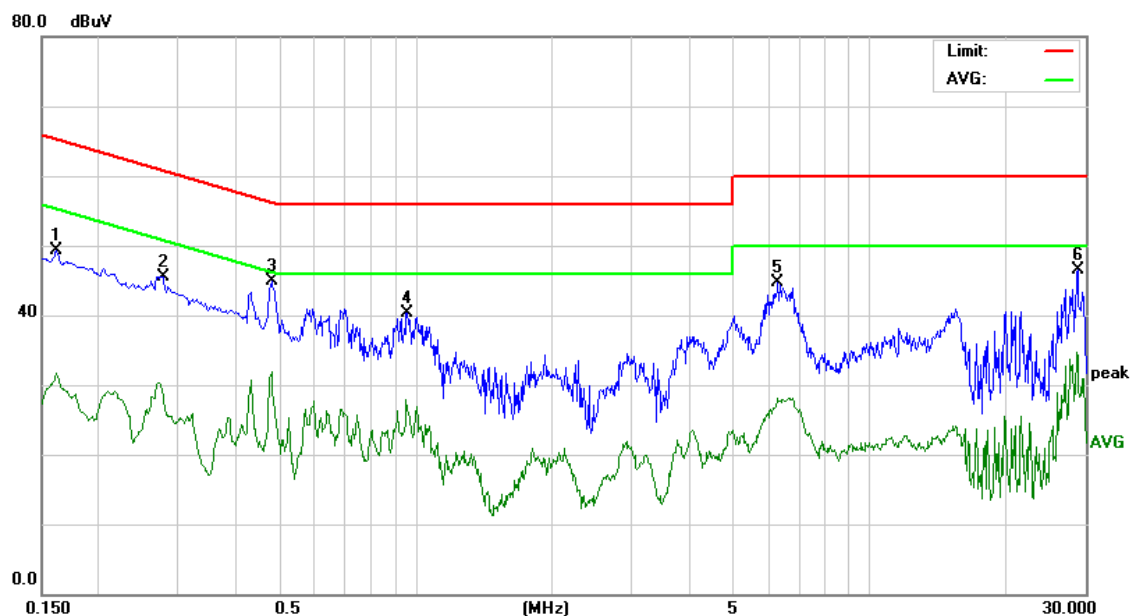

Frequency (MHz)	Reading (dBuV)	Factor (dB)	Result (dB)	Limit (dBuV)	Margin (dBuV)	Detector (dBuV)
0.16	44.85	9.92	54.77	65.36	-10.59	Peak
0.21	41.87	9.99	51.86	63.04	-11.18	Peak
0.27	40.76	9.99	50.75	61.24	-10.49	Peak
0.43	37.89	9.98	47.87	57.18	-9.31	Peak
0.43	30.18	9.98	40.16	47.18	-7.02	AVG
0.48	41.20	10.00	51.20	56.30	-5.10	Peak
0.48	33.00	10.00	43.00	46.30	-3.30	AVG
0.59	37.56	10.01	47.57	56.00	-8.43	Peak
0.60	26.96	10.01	36.97	46.00	-9.03	AVG

## 4.2 6DB BANDWIDTH AND OCCUPIED BANDWIDTH(99%)

### 4.2.1 Test Limit

According to §15.247(a)(2) and RSS-247 section 5.2(a)

#### 6 dB Bandwidth :

Limit	Shall be at least 500kHz
-------	--------------------------

Occupied Bandwidth(99%) : For reporting purposes only.

### 4.2.2 Test Procedure

Test method Refer as KDB 558074 D01 v03r05, Section 8.1 and ANSI 63.10:2013 clause 11.8.1.

1. The EUT RF output connected to the spectrum analyzer by RF cable.
2. Setting maximum power transmit of EUT
3. SA set RBW = 100kHz, VBW = 300kHz and Detector = Peak, to measurement 6 dB Bandwidth and 99% Bandwidth.
4. Measure and record the result of 6 dB Bandwidth and 99% Bandwidth. in the test report.

### 4.2.3 Test Setup

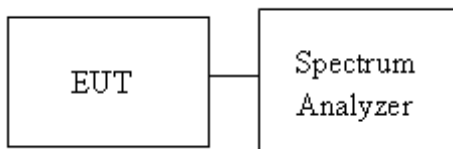

### 4.2.4 Test Result

Test mode: BLE mode / 2402-2480 MHz				
Channel	Frequency (MHz)	OBW(99%) (MHz)	6dB BW (MHz)	6dB limit (kHz)
Low	2402	1.0723	0.7087	>500
Mid	2440	1.0723	0.7130	
High	2480	1.0767	0.7043	



**Test Data**

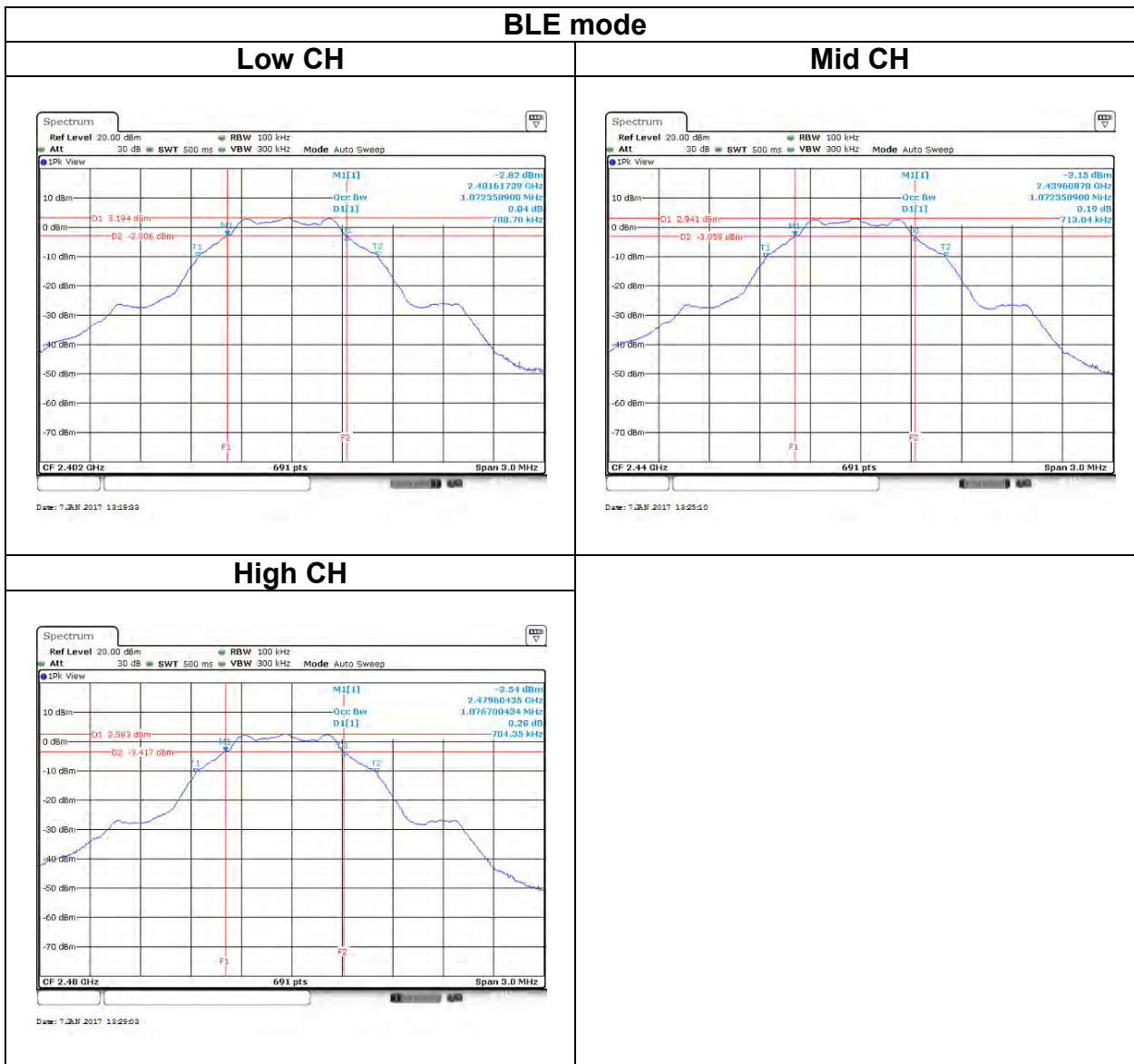

### 4.3 OUTPUT POWER MEASUREMENT

#### 4.3.1 Test Limit

According to §15.247(b) and RSS-247 section 5.4(d)

**Peak output power :**

For systems using digital modulation in the 2400-2483.5 MHz, and 5725-5850 MHz bands: 1 Watt(30 dBm), base on the use of antennas with directional gain not exceed 6 dBi If transmitting antennas of directional gain greater than 6dBi are used the peak output power the conducted output power from the intentional radiator shall be reduced by the amount in dB that the directional gain of the antenna exceeds 6 dBi. In case of point-to-point operation, the limit has to be reduced by 1dB for every 3 dB that the directional gain of the antenna exceeds 6 dBi.

Limit	<input checked="" type="checkbox"/> Antenna not exceed 6 dBi : 30dBm <input type="checkbox"/> Antenna with DG greater than 6 dBi [ Limit = 30 – (DG – 6) ] <input type="checkbox"/> Point-to-point operation
-------	---

**Average output power** : For reporting purposes only.

#### 4.3.2 Test Procedure

Test method Refer as KDB 558074 D01 v03r05, section 9.1.2.

1. The EUT RF output connected to the power meter by RF cable.
2. Setting maximum power transmit of EUT.
3. The path loss was compensated to the results for each measurement.
4. Measure and record the result of Peak output power and Average output power. in the test report.

#### 4.3.3 Test Setup

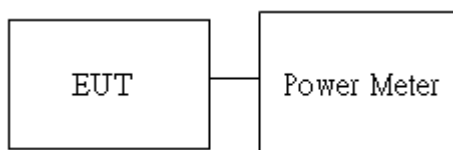

### 4.3.4 Test Result

**Peak output power :**

BLE Mode							
Config.	CH	Freq. (MHz)	PK Power (dBm)	EIRP PK Power (dBm)	PK Power (W)	EIRP PK Power (W)	FCC/IC Limit (dBm)
BLE Data rate: 1Mbps	0	2402	5.95	6.58	0.0039	0.0045	30
	19	2440	5.18	5.81	0.0033	0.0038	
	39	2480	4.80	5.43	0.0030	0.0035	

**Average output power :**

BLE Mode			
Config.	CH	Freq. (MHz)	AV Power (dBm)
BLE Data rate: 1Mbps	0	2402	5.22
	19	2440	4.46
	39	2480	4.05

## 4.4 POWER SPECTRAL DENSITY

### 4.4.1 Test Limit

According to §15.247(e) and RSS-247 section 5.2(b)

For digitally modulated systems, the power spectral density conducted from the intentional radiator to the antenna shall not be greater than 8 dBm in any 3 kHz band during any time interval of continuous transmission.

Limit	<input checked="" type="checkbox"/> Antenna not exceed 6 dBi : 8dBm <input type="checkbox"/> Antenna with DG greater than 6 dBi : 8dBm [ Limit = 8 – (DG – 6) ] <input type="checkbox"/> Point-to-point operation :
-------	--

### 4.4.2 Test Procedure

Test method Refer as KDB 558074 D01 v03r05, Section 10.2

1. The EUT RF output connected to the spectrum analyzer by RF cable.
2. Setting maximum power transmit of EUT
3. SA set RBW = 3kHz, VBW = 30kHz, Span = 1.5 times DTS Bandwidth (6 dB BW), Detector = Peak, Sweep Time = Auto and Trace = Max hold.
4. The path loss and Duty Factor were compensated to the results for each measurement by SA.
5. Mark the maximum level.
6. Measure and record the result of power spectral density. in the test report.

### 4.4.3 Test Setup

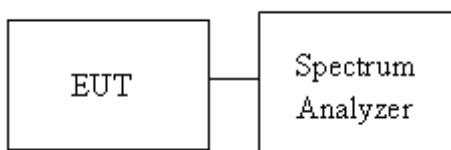

### 4.4.4 Test Result

Test mode: BLE mode / 2402-2480 MHz			
Channel	Frequency (MHz)	PSD (dBm)	IC/FCC limit (dBm)
Low	2402	-8.06	8
Mid	2440	-8.43	
High	2480	-8.81	

## Test Data

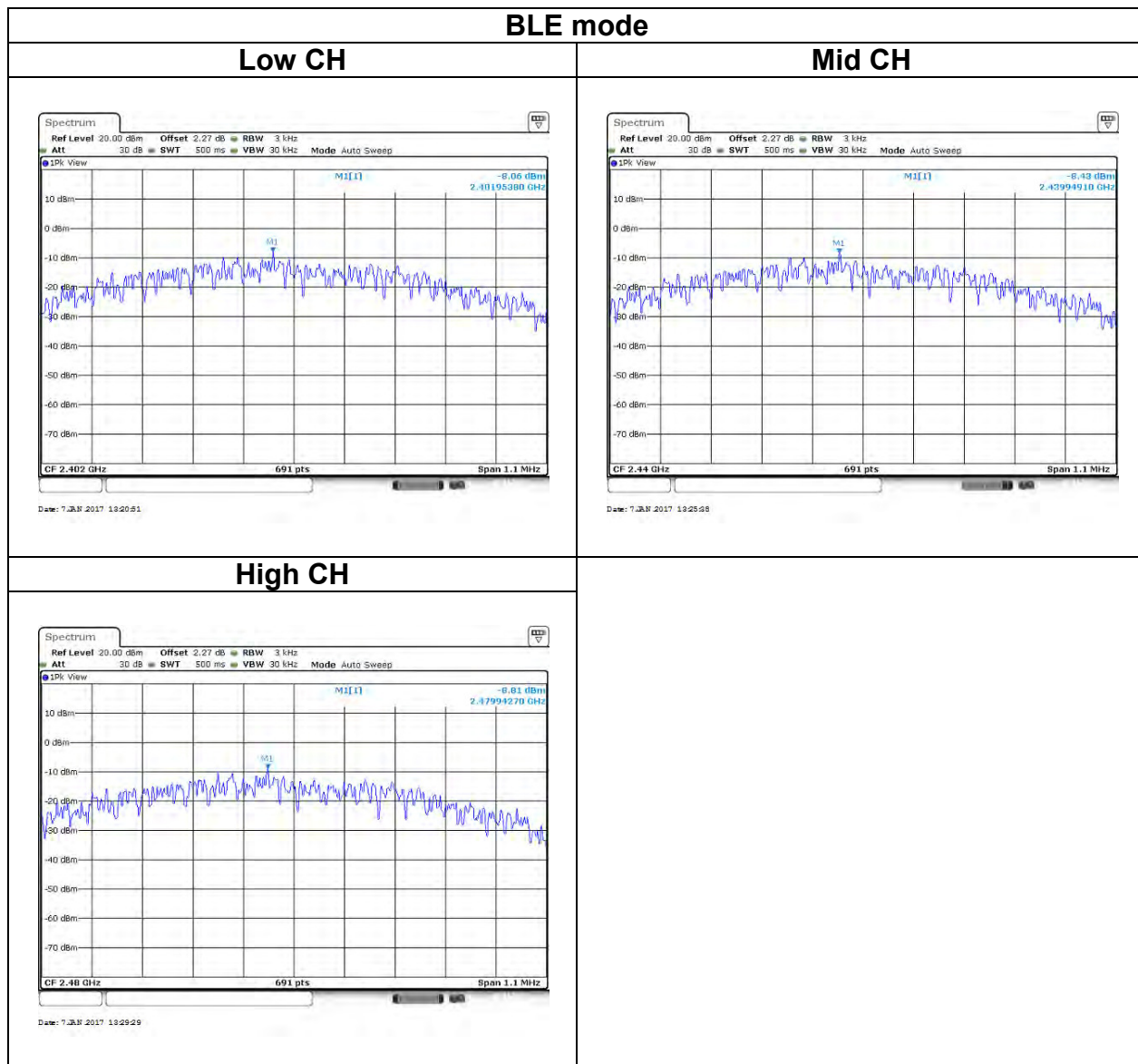

## 4.5 CONDUCTED BAND EDGE AND SPURIOUS EMISSION

### 4.5.1 Test Limit

According to §15.247(d) and RSS-247 section 5.5

In any 100 kHz bandwidth outside the authorized frequency band,

Non-restricted bands shall be attenuated at least 20 dB/30 dB relative to the maximum PSD level in 100 kHz by RF conducted or a radiated measurement which fall in the restricted bands, as defined in §15.205(a), must also comply with the radiated emission limits specified in §15.209(a).

### 4.5.2 Test Procedure

Test method Refer as KDB 558074 D01 v03r05, Section 11.

1. EUT RF output port connected to the SA by RF cable, and the path loss was compensated to result.
2. SA setting, RBW=100kHz, VBW=300kHz, Detector=Peak, Trace mode = max hold, SWT = Auto.
3. In any 100 kHz bandwidth outside the authorized frequency band, shall be attenuated at least 20 dB relative to the maximum in-band peak PSD level in 100 kHz when conducted power procedure is used. If the transmitter complies with the conducted power limits based on the use of RMS averaging over a time interval, the attenuation required under this paragraph shall be 30 dB instead of 20 dB.

### 4.5.3 Test Setup



### 4.5.4 Test Result

#### Test Data

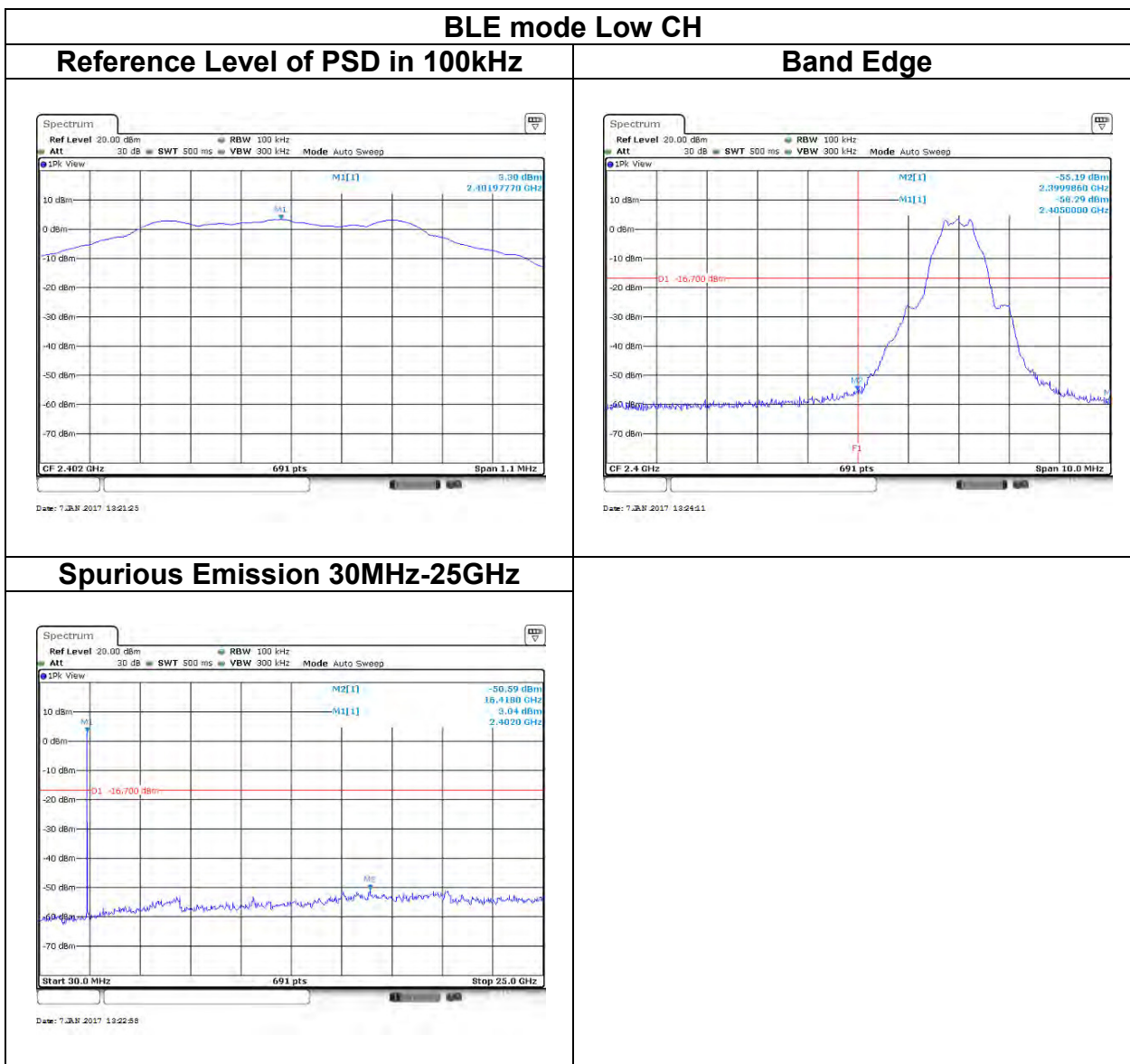

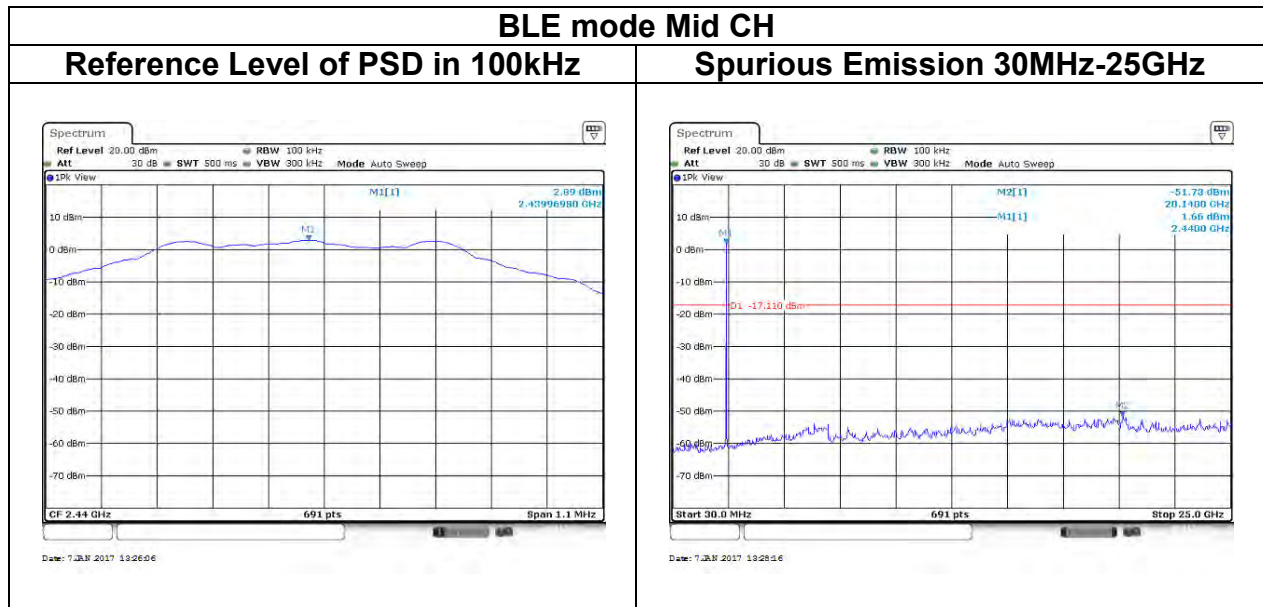



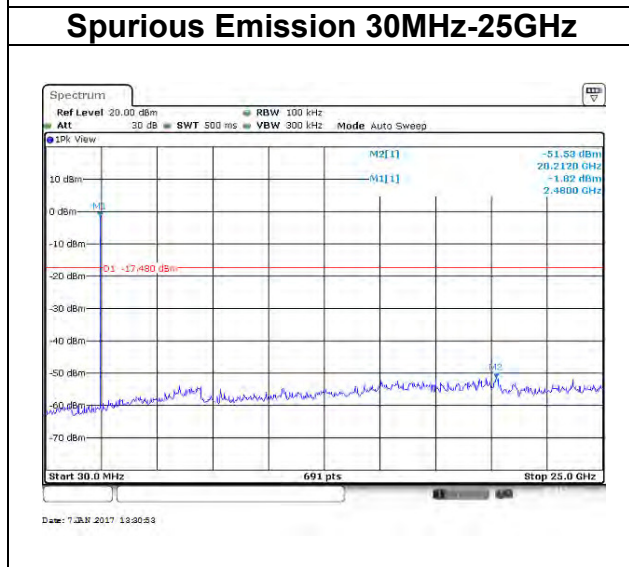
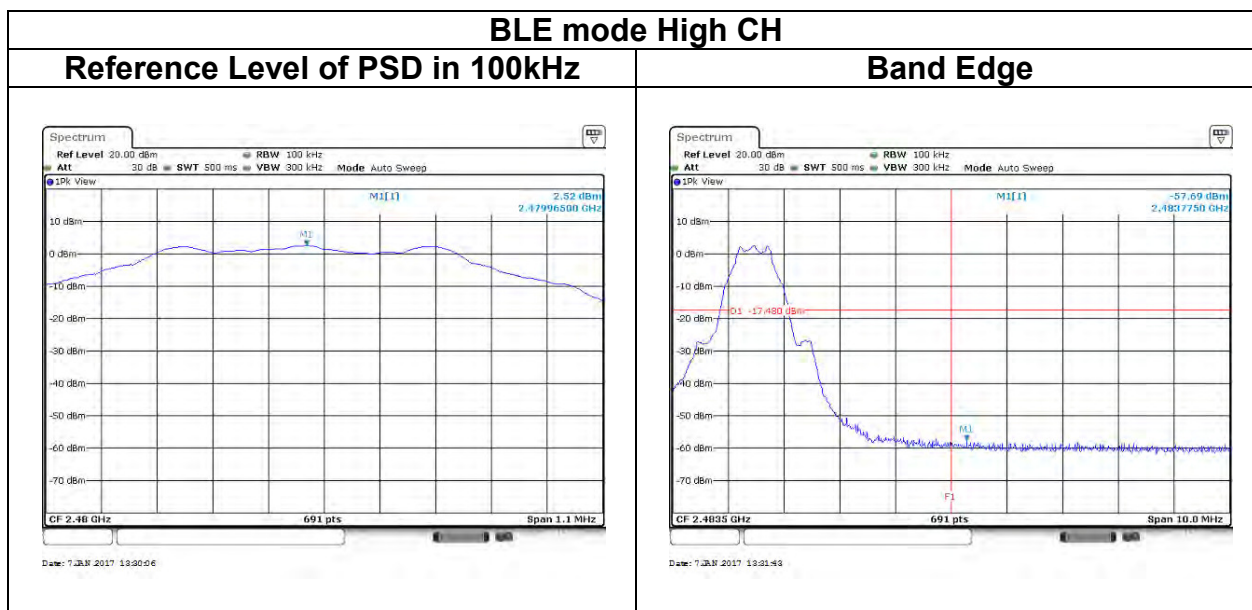

## 4.6 RADIATION BANDEGE AND SPURIOUS EMISSION

### 4.6.1 Test Limit

FCC according to §15.247(d), §15.209 and §15.205,

IC according to RSS-247 section 5.5, RSS-Gen, Section 8.9 and 8.10

In any 100 kHz bandwidth outside the authorized frequency band, all harmonic and spurious must be least 20 dB below the highest emission level with the authorized frequency band. Radiation emission which fall in the restricted bands must also follow the FCC section 15.209 as below limit in table.

#### Below 30 MHz

Frequency	Field Strength (microvolts/m)	Magnetic H-Field (microamperes/m)	Measurement Distance (metres)
9-490 kHz	2,400/F (F in kHz)	2,400/F (F in kHz)	300
490-1,705 kHz	24,000/F (F in kHz)	24,000/F (F in kHz)	30
1.705-30 MHz	30	N/A	30

#### Above 30 MHz

Frequency (MHz)	Field Strength microvolts/m at 3 metres (watts, e.i.r.p.)	
	Transmitters	Receivers
30-88	100 (3 nW)	100 (3 nW)
88-216	150 (6.8 nW)	150 (6.8 nW)
216-960	200 (12 nW)	200 (12 nW)
Above 960	500 (75 nW)	500 (75 nW)

### 4.6.2 Test Procedure

Test method Refer as KDB 558074 D01 v03r05, Section 12.1.

1. The EUT is placed on a turntable, Above 1 GHz is 1.5m and below 1 GHz is 0.8m above ground plane. The EUT Configured un accordance with ANSI C63.10, and the EUT set in a continuous mode.
2. The turntable shall be rotated for 360 degrees to determine the position of maximum emission level. And EUT is set 3m away from the receiving antenna, which is scanned from 1m to 4m above the ground plane to find out the highest emissions. Measurement are made polarized in both the vertical and the horizontal positions with antenna.
3. Span shall wide enough to full capture the emission measured. The SA from 30MHz to 26.5GHz set to the low, Mid and High channels with the EUT transmit.
4. The SA setting following :
  - (1) Below 1G : RBW = 100kHz, VBW  $\geq$  3 RBW, Sweep = Auto, Detector = Peak, Trace = Max hold.
  - (2) Above 1G :
    - (2.1) For Peak measurement : RBW = 1MHz, VBW  $\geq$  3 RBW, Sweep = Auto, Detector = Peak, Trace = Max hold.
    - (2.2) For Average measurement : RBW = 1MHz, VBW
      - If Duty Cycle  $\geq$  98%, VBW=10Hz.
      - If Duty Cycle < 98%, VBW=1/T.

Configuration	Duty Cycle (%)	VBW
BLE	72	2.4kHz

### 4.6.3 Test Setup

#### 9kHz ~ 30MHz

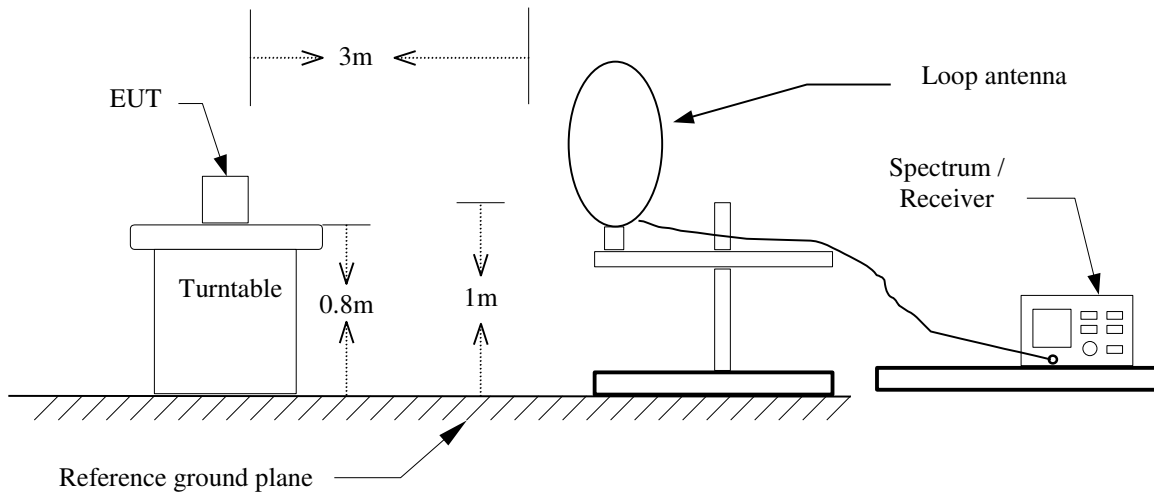

#### 30MHz ~ 1GHz

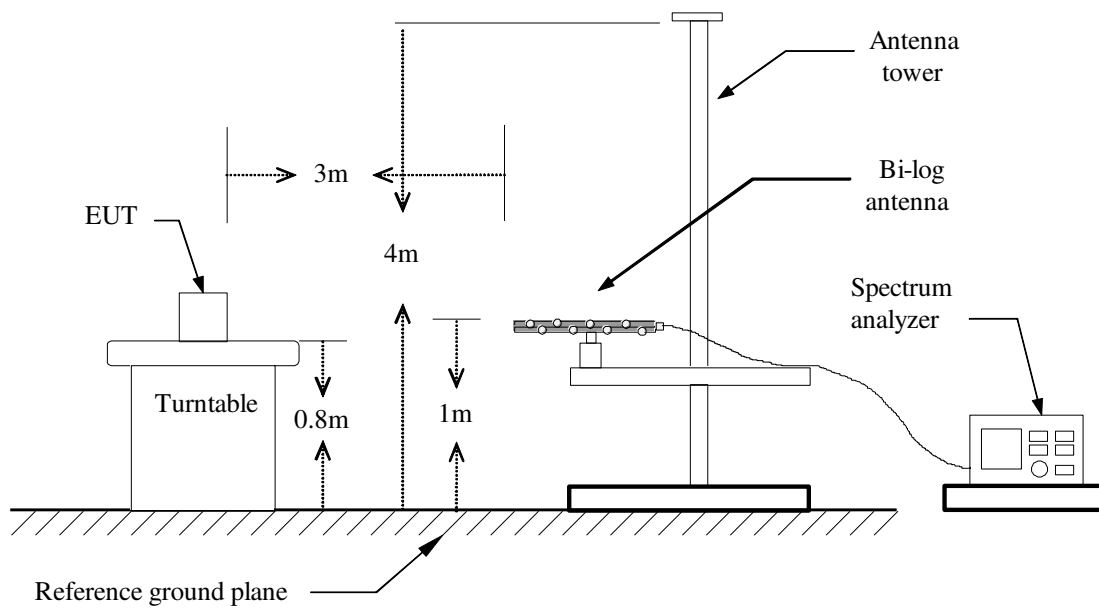

**Above 1 GHz**

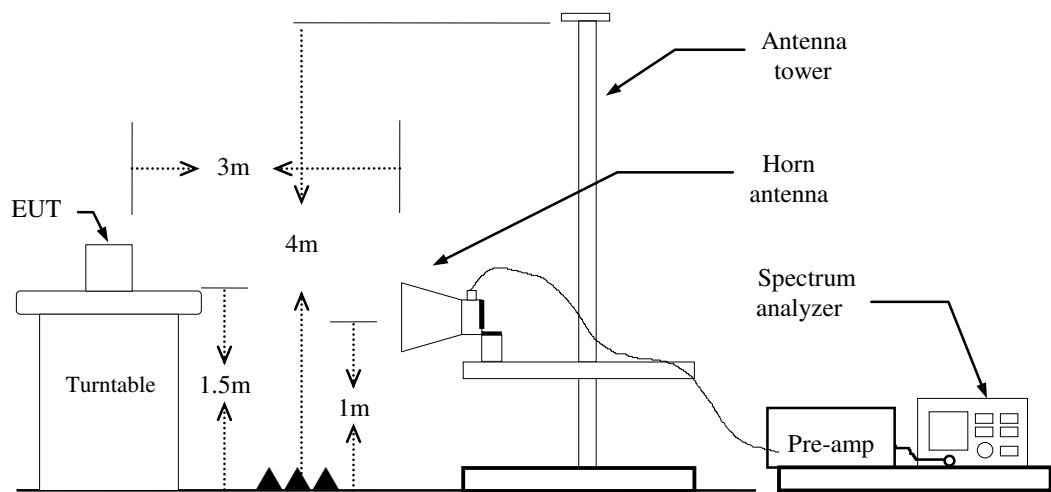

### 4.6.4 Test Result

#### Band Edge Test Data

Test Mode:	BLE Low CH	Temp/Hum	27(°C) / 53%RH
Test Item	Band Edge	Test Date	Jan 18, 2017
Polarize	Horizontal	Test Engineer	Ed Chiang
Detector	Peak	Test Voltage:	120Vac / 60Hz

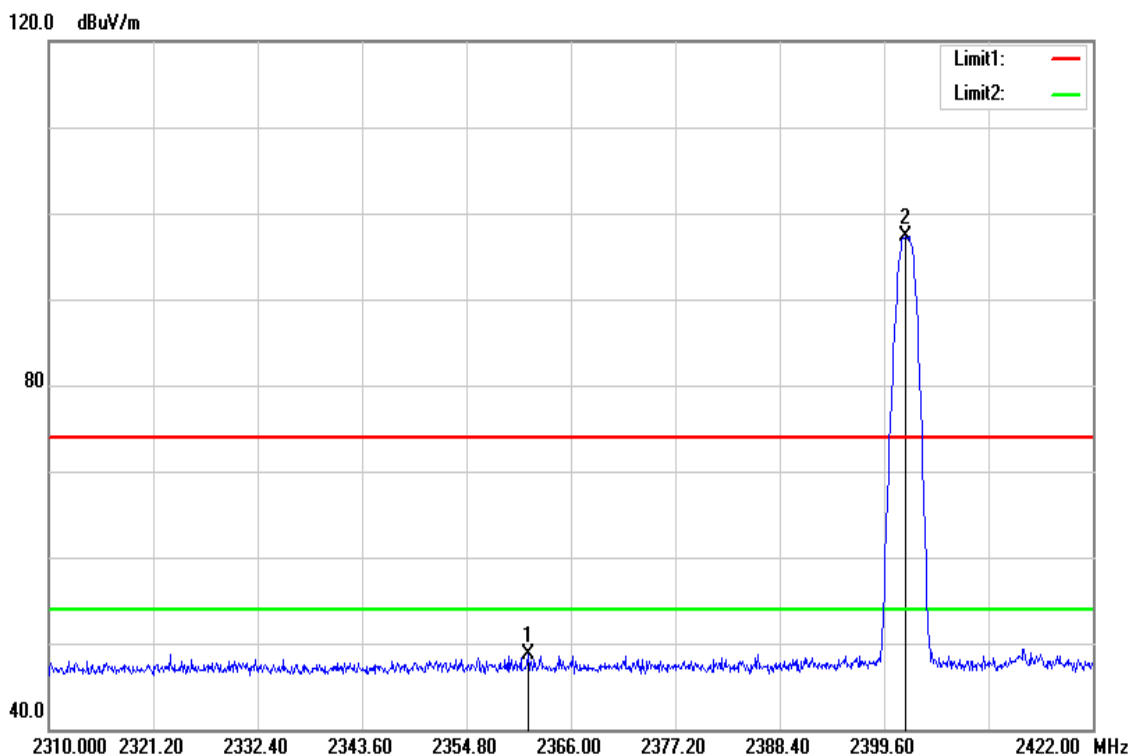

Frequency (MHz)	Reading (dBuV)	Correct Factor (dB/m)	Result (dBuV/m)	Limit (dBuV/m)	Margin (dB)	Remark
2361.408	52.09	-3.42	48.67	74.00	-25.33	Peak
2401.840	100.47	-3.25	97.22	-	-	Peak

Test Mode:	BLE Low CH	Temp/Hum	27(°C) / 53%RH
Test Item	Band Edge	Test Date	Jan 18, 2017
Polarize	Horizontal	Test Engineer	Ed Chiang
Detector	Average	Test Voltage:	120Vac / 60Hz

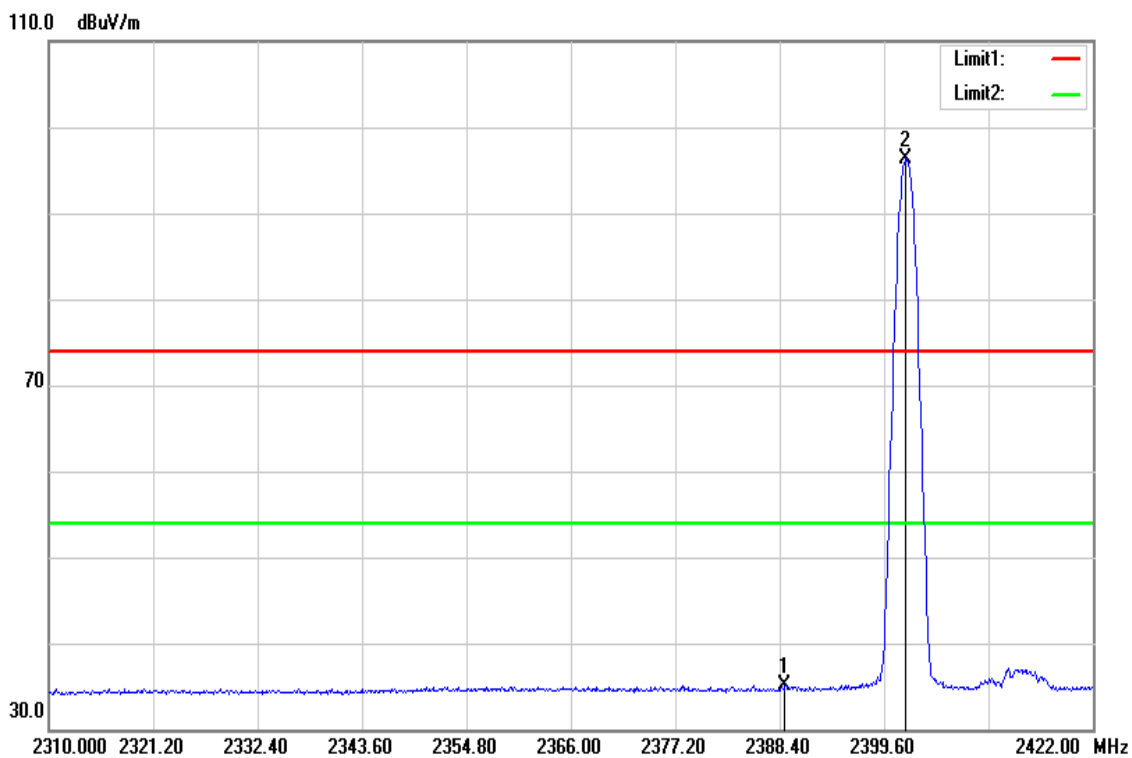

Frequency (MHz)	Reading (dBuV)	Correct Factor (dB/m)	Result (dBuV/m)	Limit (dBuV/m)	Margin (dB)	Remark
2388.960	38.42	-3.29	35.13	54.00	-18.87	AVG
2401.952	99.65	-3.25	96.40	-	-	AVG

Test Mode:	BLE High CH	Temp/Hum	27(°C)/ 53%RH
Test Item	Band Edge	Test Date	Jan 18, 2017
Polarize	Horizontal	Test Engineer	Ed Chiang
Detector	Peak	Test Voltage:	120Vac / 60Hz

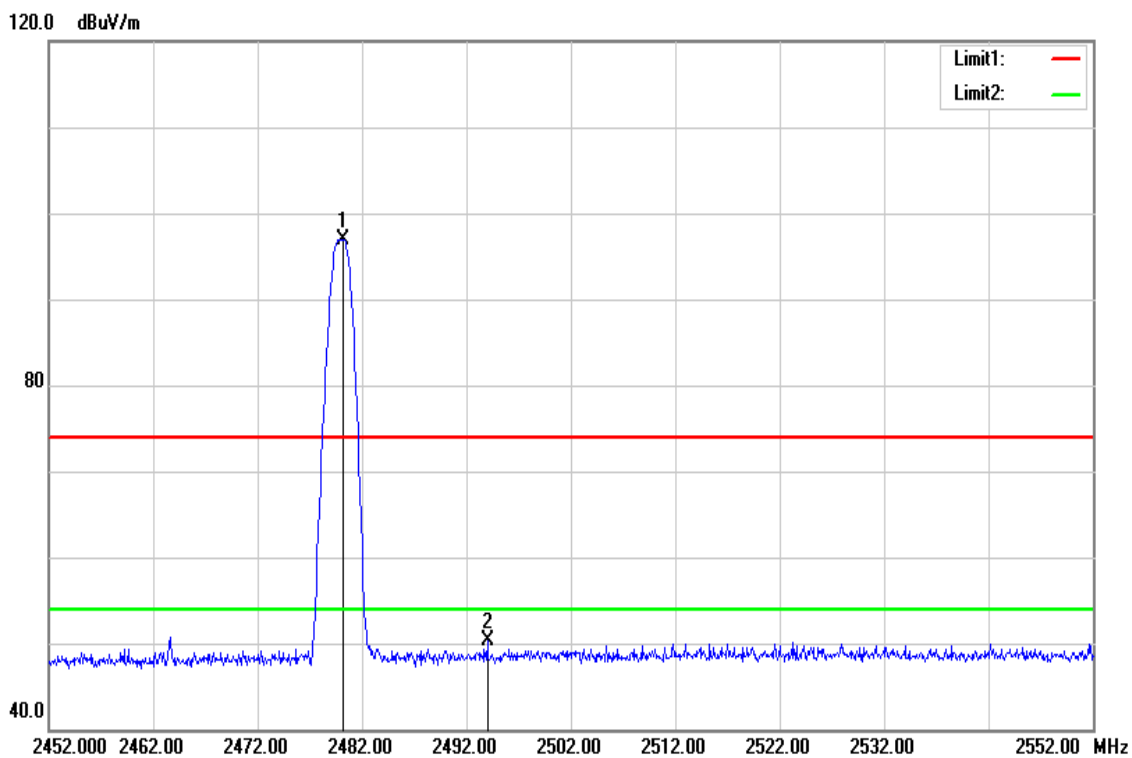

Frequency (MHz)	Reading (dBuV)	Correct Factor (dB/m)	Result (dBuV/m)	Limit (dBuV/m)	Margin (dB)	Remark
2480.200	98.94	-2.03	96.91	-	-	Peak
2494.000	52.14	-1.90	50.24	74.00	-23.76	Peak



Test Mode:	BLE High CH	Temp/Hum	27(°C) / 53%RH
Test Item	Band Edge	Test Date	Jan 18, 2017
Polarize	Horizontal	Test Engineer	Ed Chiang
Detector	Average	Test Voltage:	120Vac / 60Hz

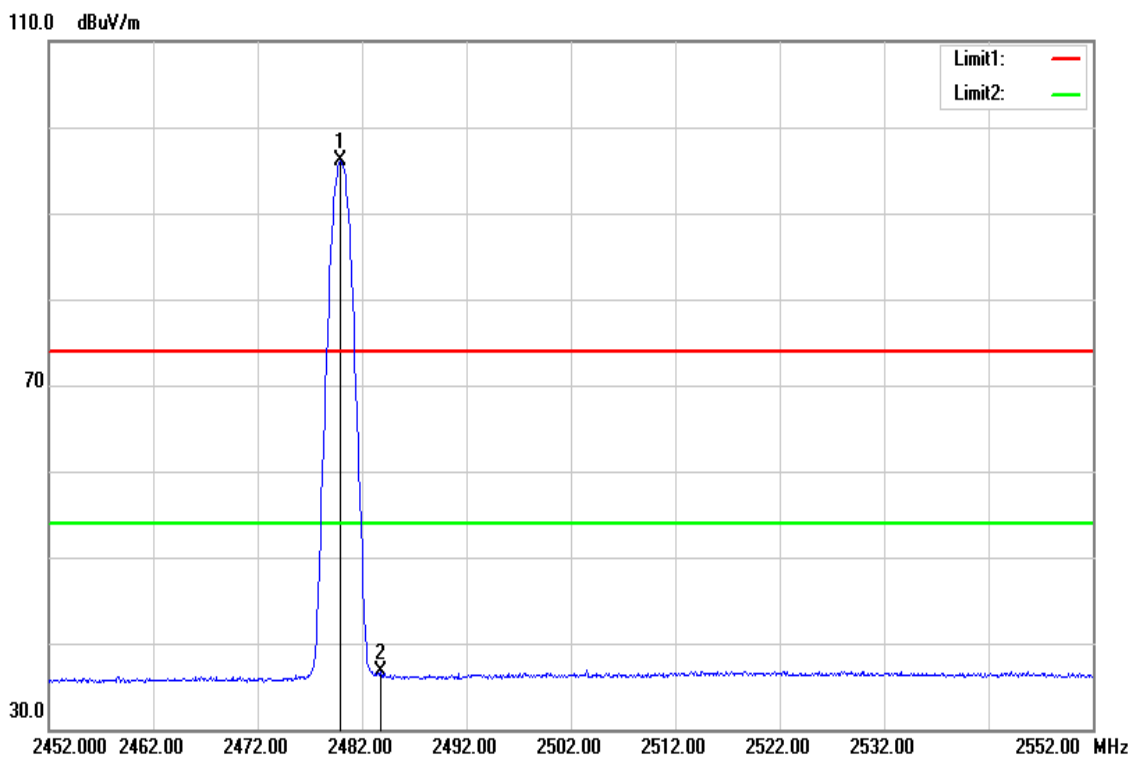

Frequency (MHz)	Reading (dBuV)	Correct Factor (dB/m)	Result (dBuV/m)	Limit (dBuV/m)	Margin (dB)	Remark
2479.900	98.06	-2.03	96.03	-	-	AVG
2483.800	38.66	-1.99	36.67	54.00	-17.33	AVG

**Below 1G Test Data**

Test Mode:	BT Mode	Temp/Hum	27(°C)/ 53%RH
Test Item	30MHz-1GHz	Test Date	Jan 18, 2017
Polarize	Vertical	Test Engineer	Ed Chiang
Detector	Peak and Qusi-peak	Test Voltage:	120Vac / 60Hz

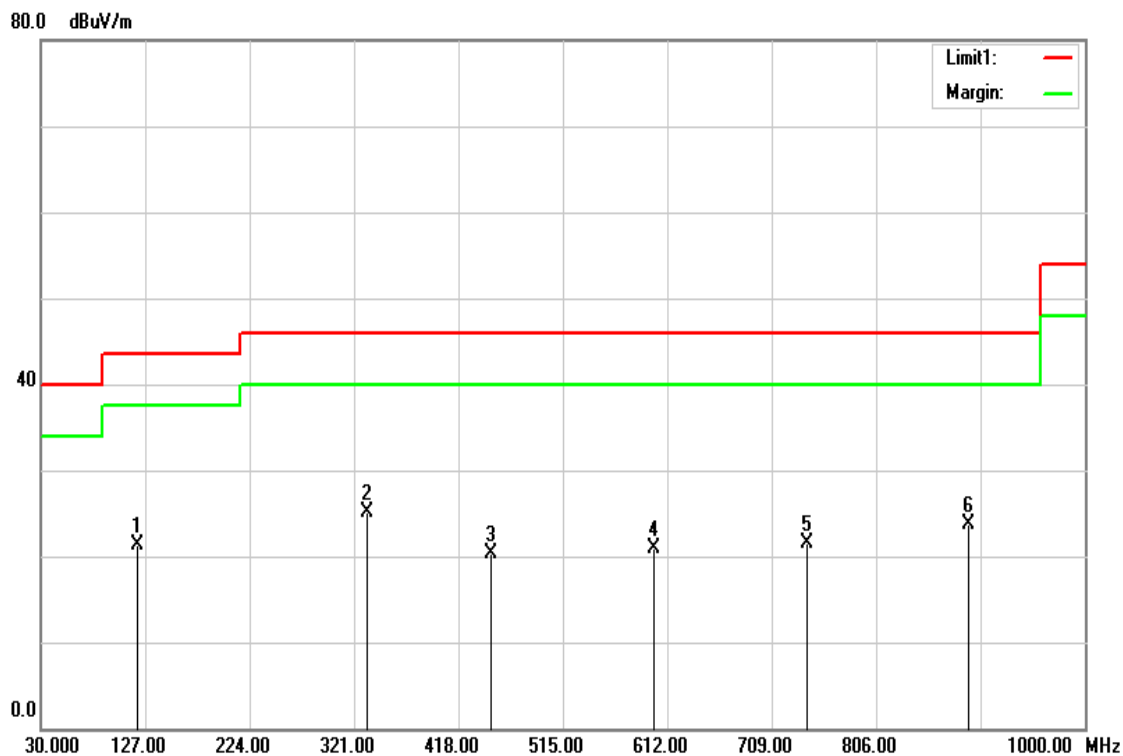

Frequency (MHz)	Reading (dBuV)	Correct Factor (dB/m)	Result (dBuV/m)	Limit (dBuV/m)	Margin (dB)	Remark
120.2100	36.78	-15.50	21.28	43.50	-22.22	Peak
333.6100	38.40	-13.33	25.07	46.00	-20.93	Peak
448.0700	30.61	-10.25	20.36	46.00	-25.64	Peak
599.3900	28.61	-7.77	20.84	46.00	-25.16	Peak
741.9800	26.55	-5.10	21.45	46.00	-24.55	Peak
892.3300	26.93	-3.28	23.65	46.00	-22.35	Peak

Test Mode:	BT Mode	Temp/Hum	27(°C)/ 53%RH
Test Item	30MHz-1GHz	Test Date	Jan 18, 2017
Polarize	Horizontal	Test Engineer	Ed Chiang
Detector	Peak and Qusi-peak	Test Voltage:	120Vac / 60Hz

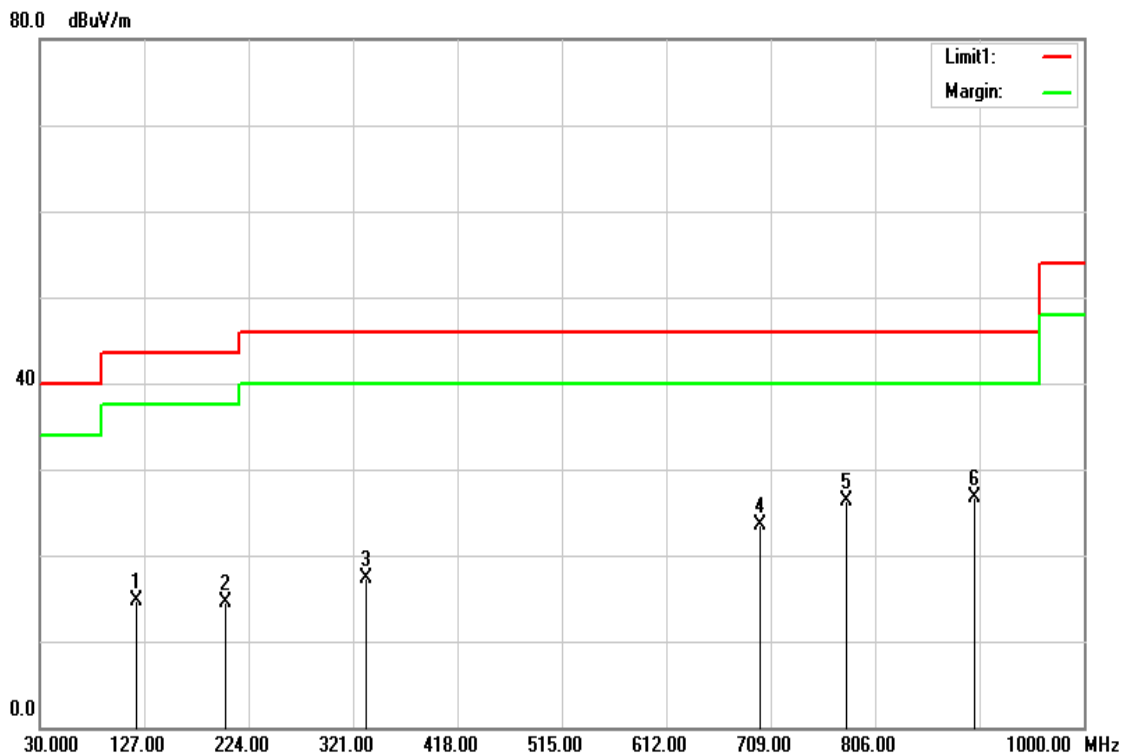

Frequency (MHz)	Reading (dBuV)	Correct Factor (dB/m)	Result (dBuV/m)	Limit (dBuV/m)	Margin (dB)	Remark
120.2100	30.23	-15.50	14.73	43.50	-28.77	Peak
202.6600	30.34	-15.74	14.60	43.50	-28.90	Peak
333.6100	30.58	-13.33	17.25	46.00	-28.75	Peak
699.3000	29.52	-6.08	23.44	46.00	-22.56	Peak
779.8100	31.01	-4.67	26.34	46.00	-19.66	Peak
898.1500	29.87	-3.21	26.66	46.00	-19.34	Peak

**Above 1G Test Data**

Test Mode:	BLE Low CH	Temp/Hum	27(°C)/ 53%RH
Test Item	Harmonic	Test Date	Jan 19, 2017
Polarize	Vertical	Test Engineer	Ed Chiang
Detector	Peak and Average	Test Voltage:	120Vac / 60Hz

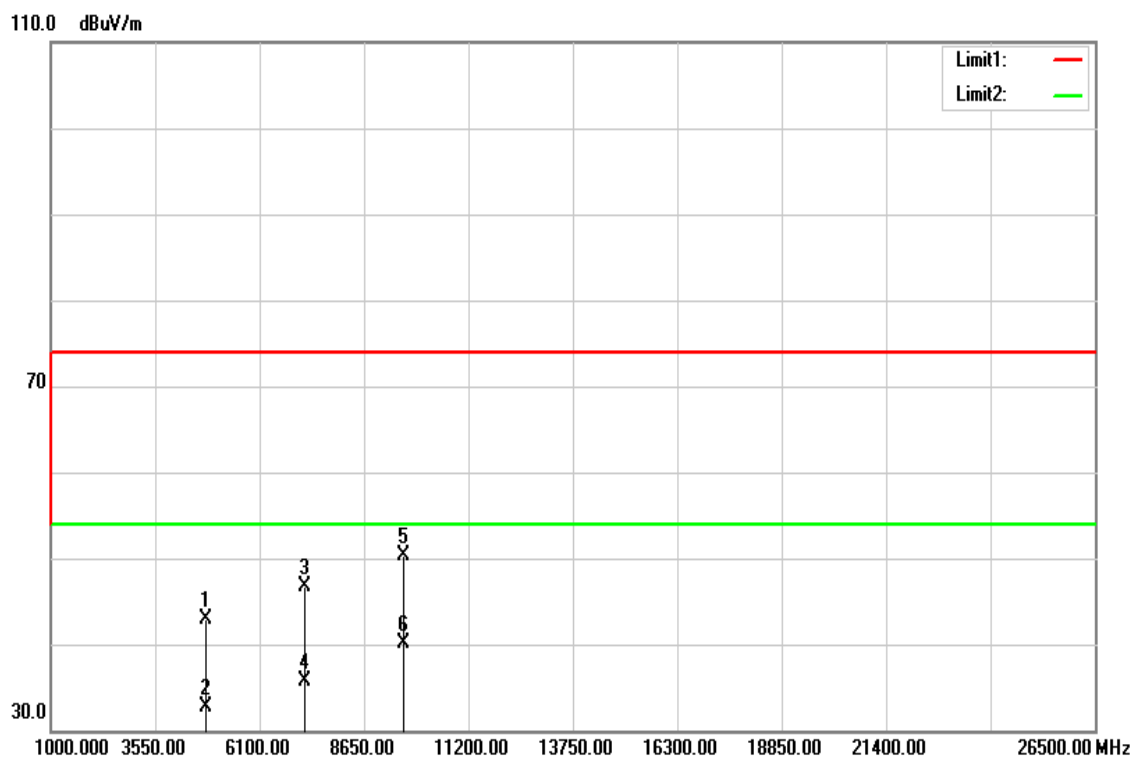

Frequency (MHz)	Reading (dBuV)	Correct Factor (dB/m)	Result (dBuV/m)	Limit (dBuV/m)	Margin (dB)	Remark
4804.000	37.86	5.04	42.90	74.00	-31.10	Peak
4804.000	27.65	5.04	32.69	54.00	-21.31	AVG
7206.000	34.17	12.62	46.79	74.00	-27.21	Peak
7206.000	23.15	12.62	35.77	54.00	-18.23	AVG
9608.000	32.69	17.60	50.29	74.00	-23.71	Peak
9608.000	22.58	17.60	40.18	54.00	-13.82	AVG

**Remark:**

1. Measuring frequency from 1 GHz to the 10th harmonic of highest fundamental frequency.
2. For above 1GHz, the EUT peak value was under average limit, therefore the Average value compliance with the average limit

Test Mode:	BLE Low CH	Temp/Hum	27(°C) / 53%RH
Test Item	Harmonic	Test Date	Jan 19, 2017
Polarize	Horizontal	Test Engineer	Ed Chiang
Detector	Peak and Average	Test Voltage:	120Vac / 60Hz

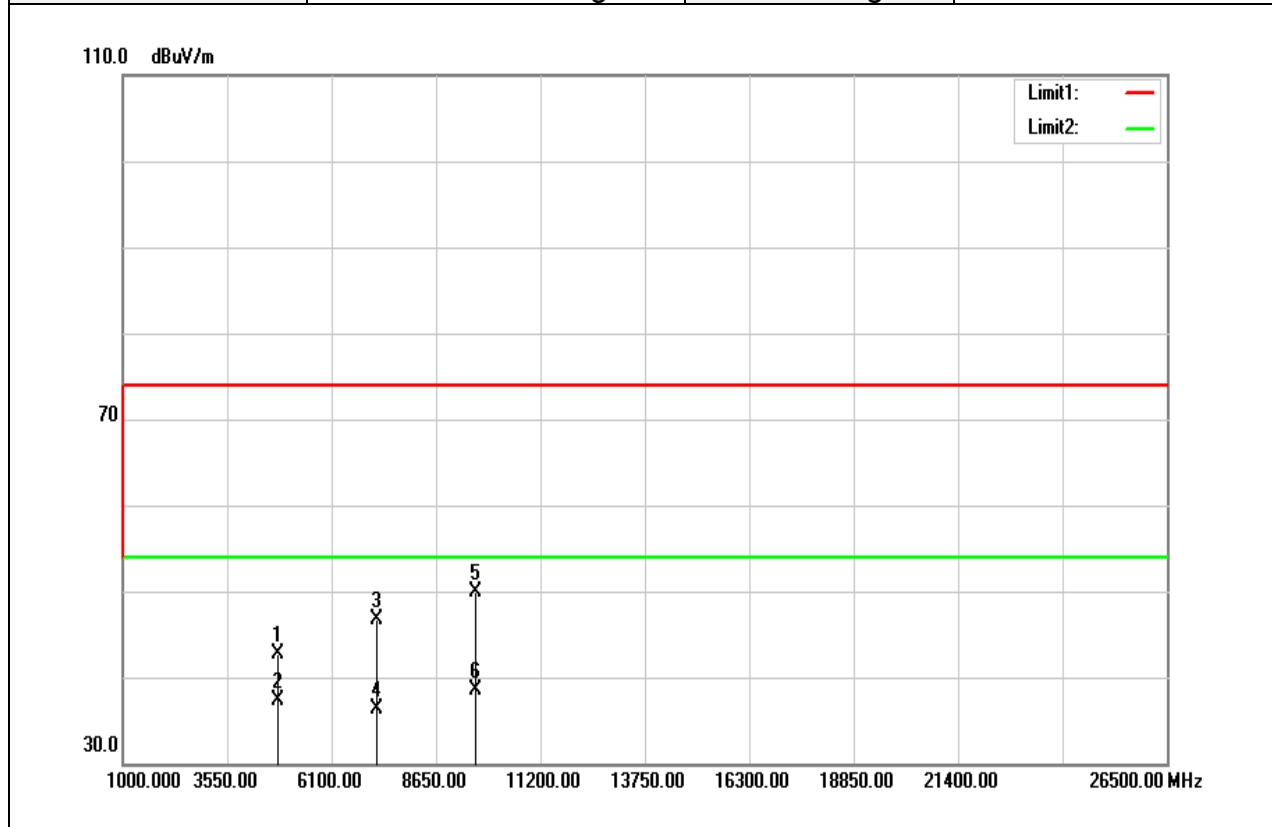

Frequency (MHz)	Reading (dBuV)	Correct Factor (dB/m)	Result (dBuV/m)	Limit (dBuV/m)	Margin (dB)	Remark
4804.000	37.75	5.04	42.79	74.00	-31.21	Peak
4804.000	32.26	5.04	37.30	54.00	-16.70	AVG
7206.000	34.14	12.62	46.76	74.00	-27.24	Peak
7206.000	23.77	12.62	36.39	54.00	-17.61	AVG
9608.000	32.38	17.60	49.98	74.00	-24.02	Peak
9608.000	20.98	17.60	38.58	54.00	-15.42	AVG

**Remark:**

1. Measuring frequencies from 1 GHz to the 10th harmonic of highest fundamental frequency.
2. For above 1GHz, the EUT peak value was under average limit, therefore the Average value compliance with the average limit

Test Mode:	BLE Mid CH	Temp/Hum	27(°C)/ 53%RH
Test Item	Harmonic	Test Date	Jan 19, 2017
Polarize	Vertical	Test Engineer	Ed Chiang
Detector	Peak and Average	Test Voltage:	120Vac / 60Hz

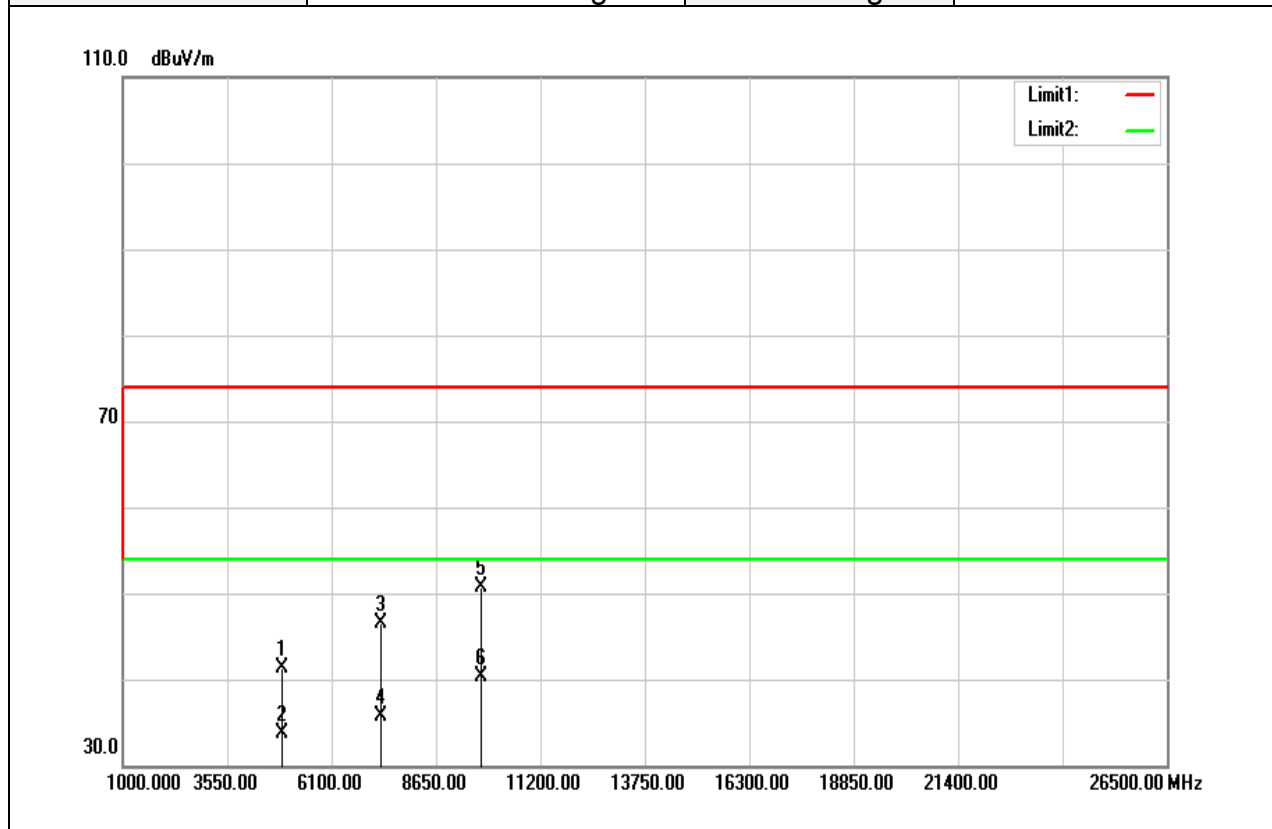

Frequency (MHz)	Reading (dBuV)	Correct Factor (dB/m)	Result (dBuV/m)	Limit (dBuV/m)	Margin (dB)	Remark
4880.000	36.00	5.25	41.25	74.00	-32.75	Peak
4880.000	28.37	5.25	33.62	54.00	-20.38	AVG
7320.000	33.51	12.97	46.48	74.00	-27.52	Peak
7320.000	22.71	12.97	35.68	54.00	-18.32	AVG
9760.000	33.16	17.60	50.76	74.00	-23.24	Peak
9760.000	22.67	17.60	40.27	54.00	-13.73	AVG

**Remark:**

1. Measuring frequencies from 1 GHz to the 10th harmonic of highest fundamental frequency.
2. For above 1GHz, the EUT peak value was under average limit, therefore the Average value compliance with the average limit

Test Mode:	BLE Mid CH	Temp/Hum	27(°C) / 53%RH
Test Item	Harmonic	Test Date	Jan 19, 2017
Polarize	Horizontal	Test Engineer	Ed Chiang
Detector	Peak and Average	Test Voltage:	120Vac / 60Hz

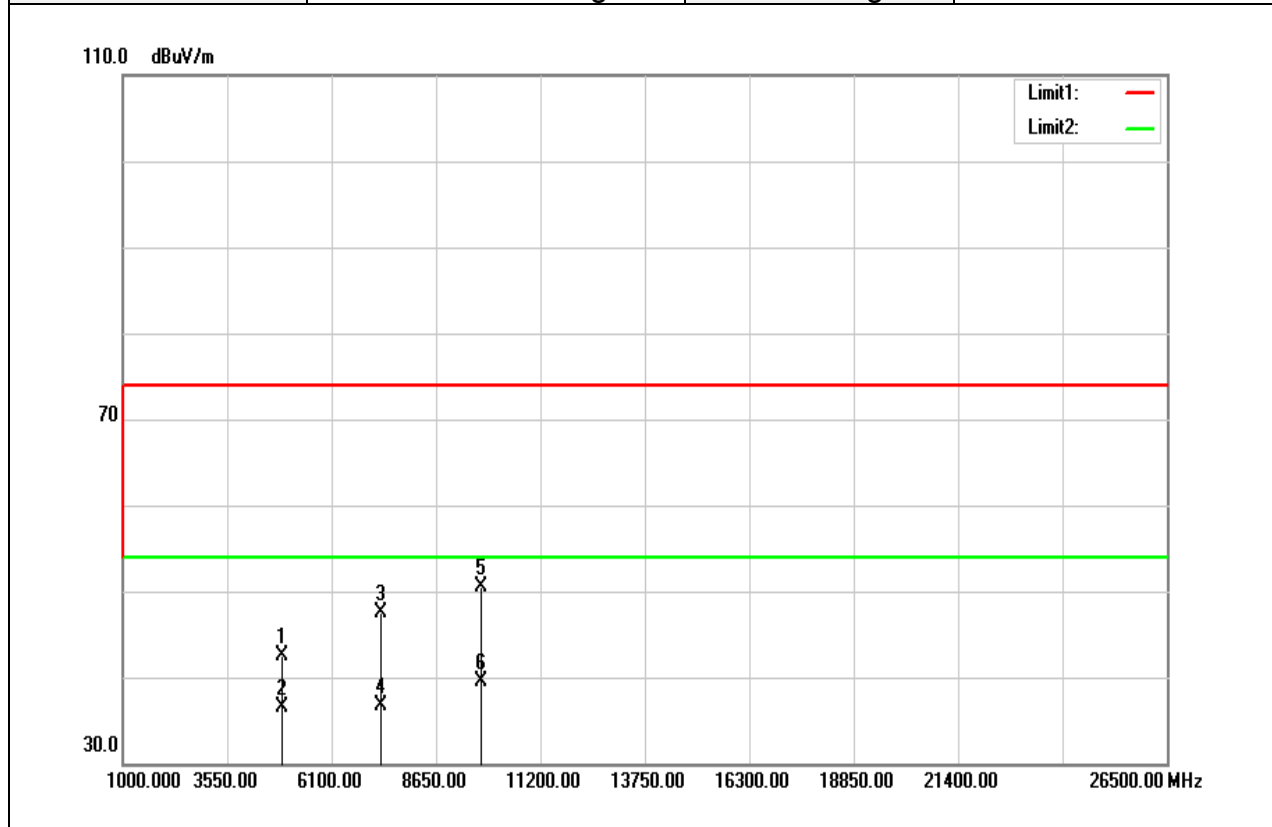

Frequency (MHz)	Reading (dBuV)	Correct Factor (dB/m)	Result (dBuV/m)	Limit (dBuV/m)	Margin (dB)	Remark
4880.000	37.29	5.25	42.54	74.00	-31.46	Peak
4880.000	31.24	5.25	36.49	54.00	-17.51	AVG
7320.000	34.57	12.97	47.54	74.00	-26.46	Peak
7320.000	23.74	12.97	36.71	54.00	-17.29	AVG
9760.000	32.88	17.60	50.48	74.00	-23.52	Peak
9760.000	21.97	17.60	39.57	54.00	-14.43	AVG

**Remark:**

1. Measuring frequencies from 1 GHz to the 10th harmonic of highest fundamental frequency.
2. For above 1GHz, the EUT peak value was under average limit, therefore the Average value compliance with the average limit

Test Mode:	BLE High CH	Temp/Hum	27(°C) / 53%RH
Test Item	Harmonic	Test Date	Jan 19, 2017
Polarize	Vertical	Test Engineer	Ed Chiang
Detector	Peak and Average	Test Voltage:	120Vac / 60Hz

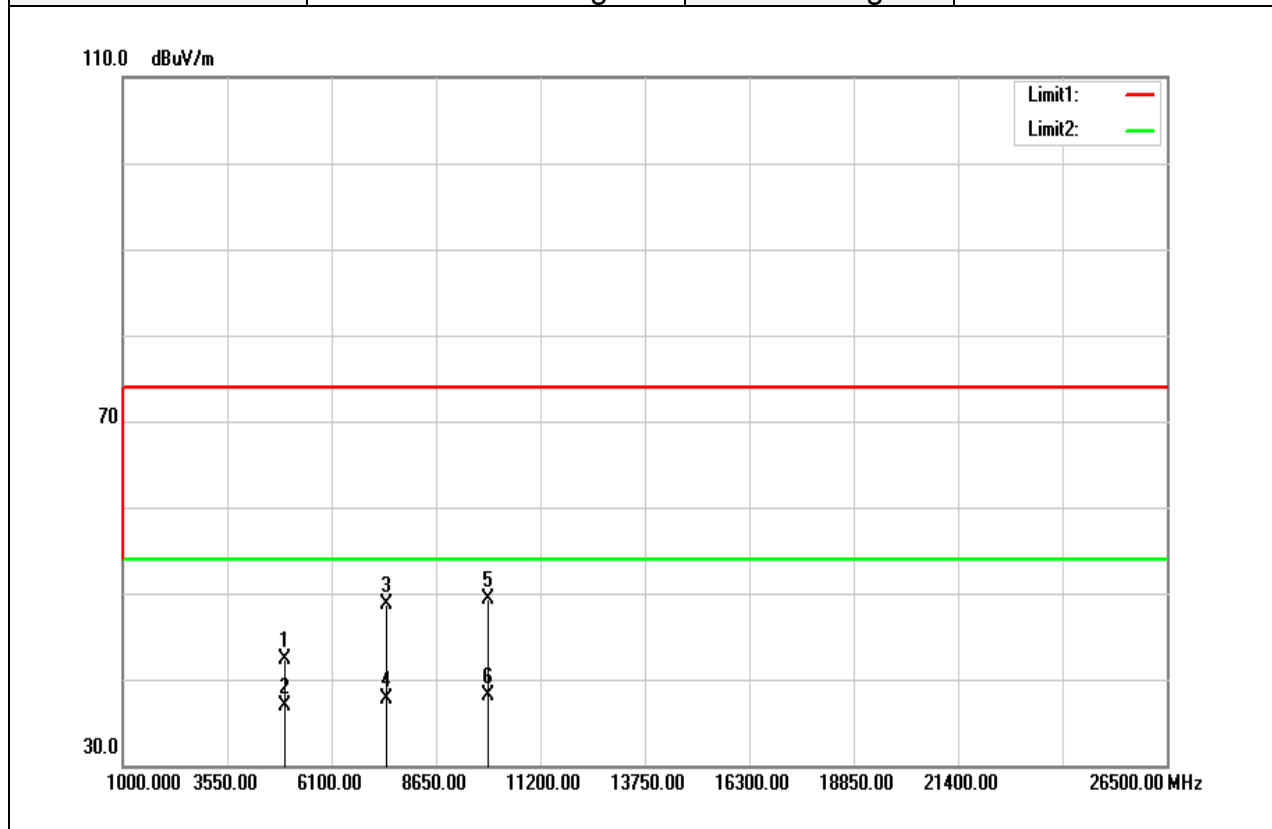

Frequency (MHz)	Reading (dBuV)	Correct Factor (dB/m)	Result (dBuV/m)	Limit (dBuV/m)	Margin (dB)	Remark
4960.000	36.74	5.46	42.20	74.00	-31.80	Peak
4960.000	31.48	5.46	36.94	54.00	-17.06	AVG
7440.000	35.38	13.33	48.71	74.00	-25.29	Peak
7440.000	24.30	13.33	37.63	54.00	-16.37	AVG
9920.000	31.66	17.60	49.26	74.00	-24.74	Peak
9920.000	20.59	17.60	38.19	54.00	-15.81	AVG

**Remark:**

1. Measuring frequencies from 1 GHz to the 10th harmonic of highest fundamental frequency.
2. For above 1GHz, the EUT peak value was under average limit, therefore the Average value compliance with the average limit



Test Mode:	BLE High CH	Temp/Hum	27(°C) / 53%RH
Test Item	Harmonic	Test Date	Jan 19, 2017
Polarize	Horizontal	Test Engineer	Ed Chiang
Detector	Peak and Average	Test Voltage:	120Vac / 60Hz

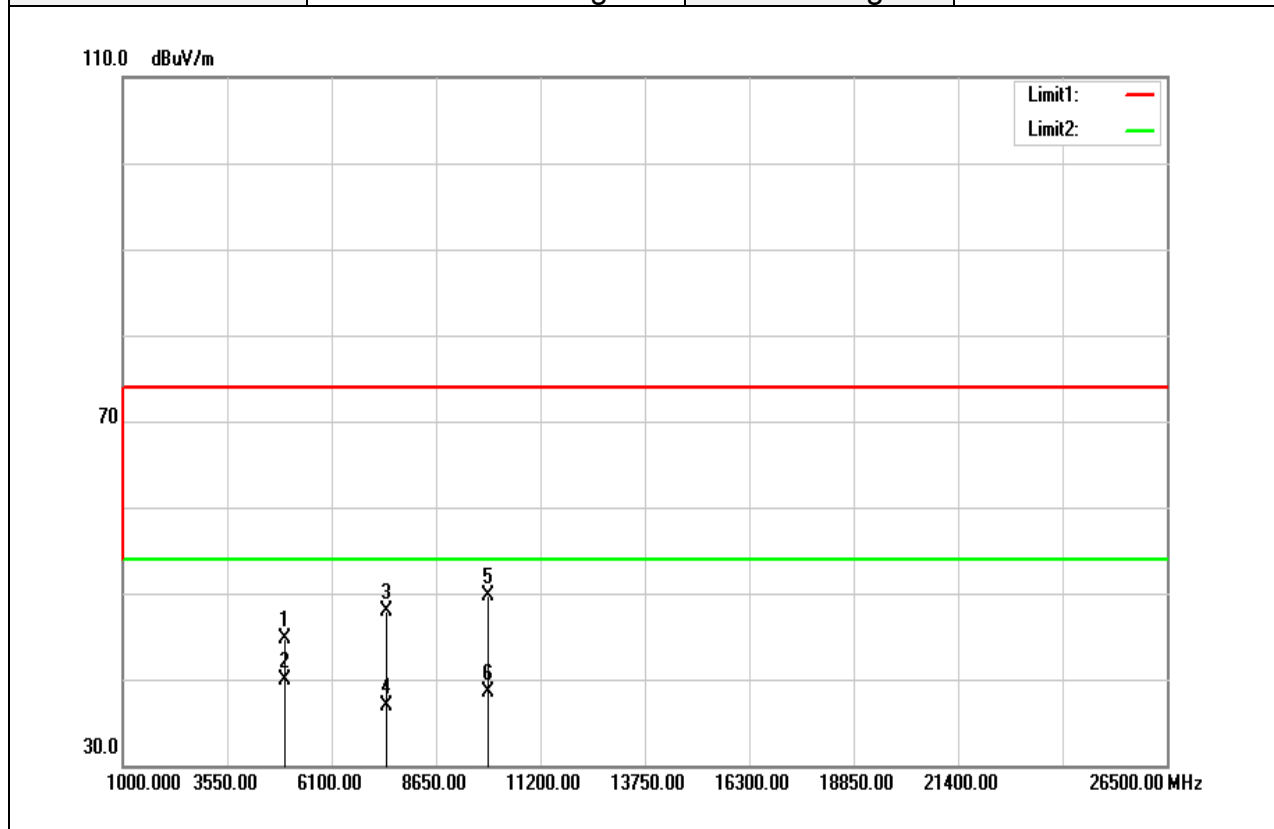

Frequency (MHz)	Reading (dBuV)	Correct Factor (dB/m)	Result (dBuV/m)	Limit (dBuV/m)	Margin (dB)	Remark
4960.000	39.24	5.46	44.70	74.00	-29.30	Peak
4960.000	34.38	5.46	39.84	54.00	-14.16	AVG
7440.000	34.59	13.33	47.92	74.00	-26.08	Peak
7440.000	23.62	13.33	36.95	54.00	-17.05	AVG
9920.000	32.04	17.60	49.64	74.00	-24.36	Peak
9920.000	20.85	17.60	38.45	54.00	-15.55	AVG

**Remark:**

1. Measuring frequencies from 1 GHz to the 10th harmonic of highest fundamental frequency.
2. For above 1GHz, the EUT peak value was under average limit, therefore the Average value compliance with the average limit