

### 3. 6 dB Bandwidth

#### 3.1. Test Setup

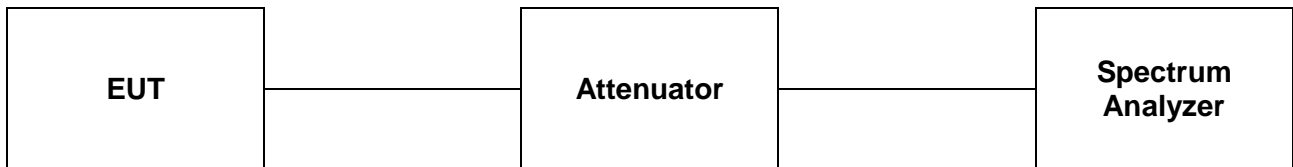

#### 3.2. Limit

According to §15.247(a)(2), systems using digital modulation techniques may operate in the 902-928 MHz, 2 400-2 483.5 MHz, and 5 725-5 850 MHz bands. The minimum of 6 dB Bandwidth shall be at least 500 kHz.

#### 3.3. Test Procedure

##### 6 dB Bandwidth

All data rates and modes were investigated for this test. The full data for the worst case data rate are reported in this section.

The test follows section 8.0 DTS bandwidth of FCC KDB Publication 558074 D01 v03r05.

Tests performed using section 8.1 Option 1

- Option 1:

1. Set RBW = 100 kHz.
2. Set the video bandwidth (VBW)  $\geq 3 \times$  RBW.
3. Detector = Peak.
4. Trace mode = max hold.
5. Sweep = auto couple.
6. Allow the trace to stabilize.
7. Measure the maximum width of the emission that is constrained by the frequencies associated with the two outermost amplitude points (upper and lower) that are attenuated by 6 dB relative to the maximum level measured in the fundamental emission.

*The results shown in this test report refer only to the sample(s) tested unless otherwise stated. This test report cannot be reproduced, except in full, without prior written permission of the Company.*

**SGS Korea Co., Ltd. (Gunpo Laboratory)** 4, LS-ro 182beon-gil, Gunpo-si, Gyeonggi-do, Korea, 15807 <http://www.sgsgroup.kr>

### 3.4. Test Results

Ambient temperature : (23 ± 1) °C

Relative humidity : 47 % R.H.

Operation Mode	Data Rate (Mbps)	Channel	Frequency (MHz)	6 dB Bandwidth (MHz)	Minimum Bandwidth (kHz)
DSSS (802.11b)	1	Low	2 412	10.165	500
		Middle	2 437	10.125	500
		High	2 462	10.110	500
OFDM (802.11g)	6	Low	2 412	16.424	500
		Middle	2 437	16.439	500
		High	2 462	16.424	500
OFDM (802.11n_HT20)	MCS8	Low	2 412	17.662	500
		Middle	2 437	17.637	500
		High	2 462	17.622	500
OFDM (802.11n_HT40)	MCS8	Low	2 422	35.804	500
		Middle	2 437	35.804	500
		High	2 452	35.564	500

The results shown in this test report refer only to the sample(s) tested unless otherwise stated. This test report cannot be reproduced, except in full, without prior written permission of the Company.

SGS Korea Co., Ltd. (Gunpo Laboratory) 4, LS-ro 182beon-gil, Gunpo-si, Gyeonggi-do, Korea, 15807 <http://www.sgsgroup.kr>

## DSSS: 802.11b

### Low Channel

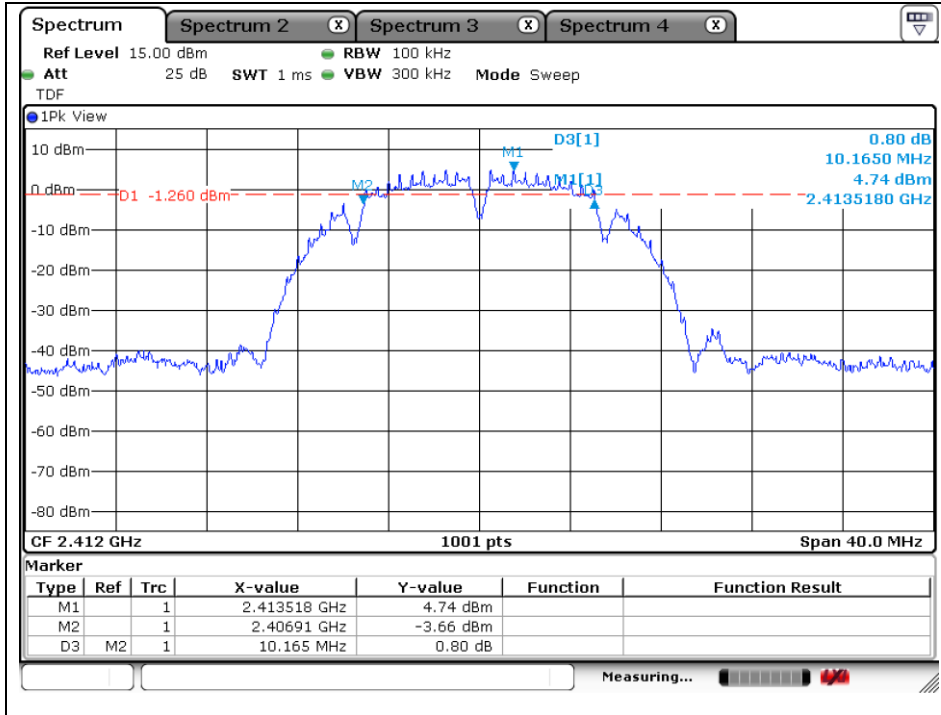

### Middle Channel

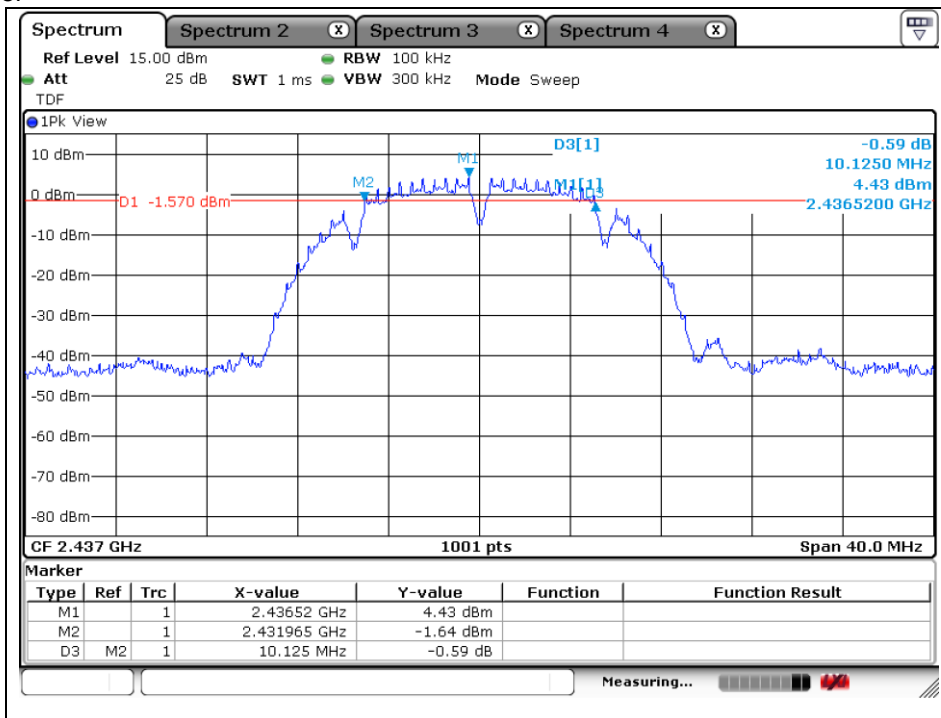

The results shown in this test report refer only to the sample(s) tested unless otherwise stated. This test report cannot be reproduced, except in full, without prior written permission of the Company.

High Channel

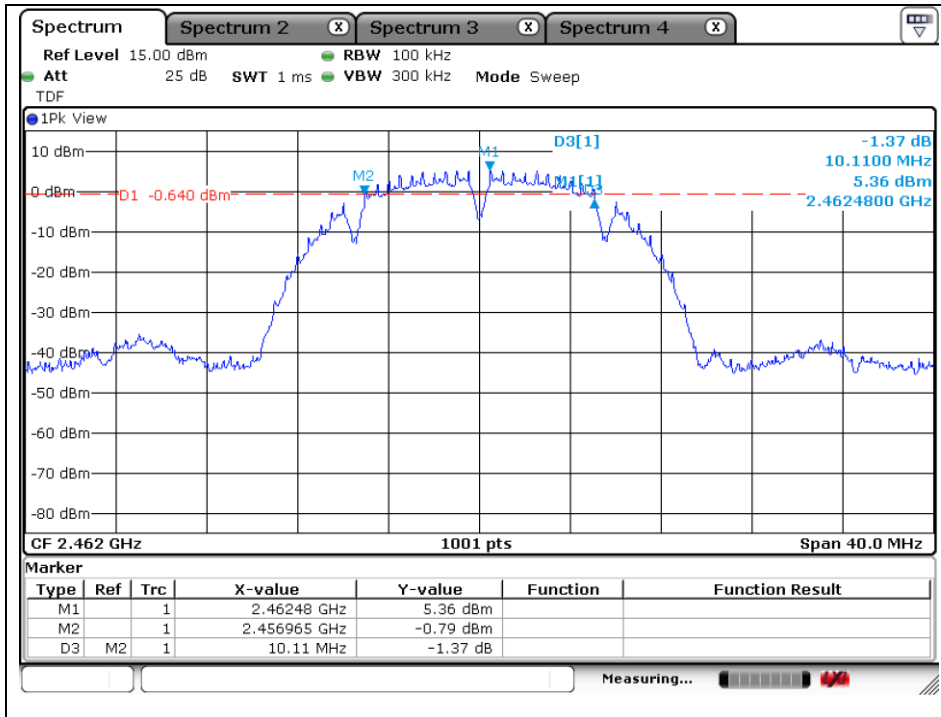

OFDM: 802.11g

Low Channel

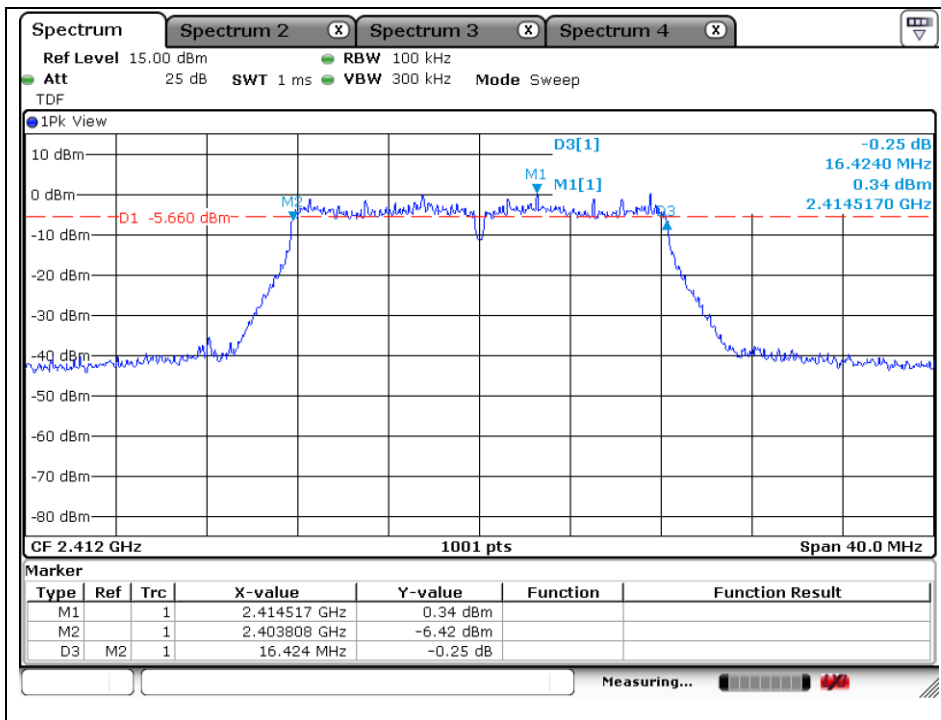

The results shown in this test report refer only to the sample(s) tested unless otherwise stated. This test report cannot be reproduced, except in full, without prior written permission of the Company.

Middle Channel

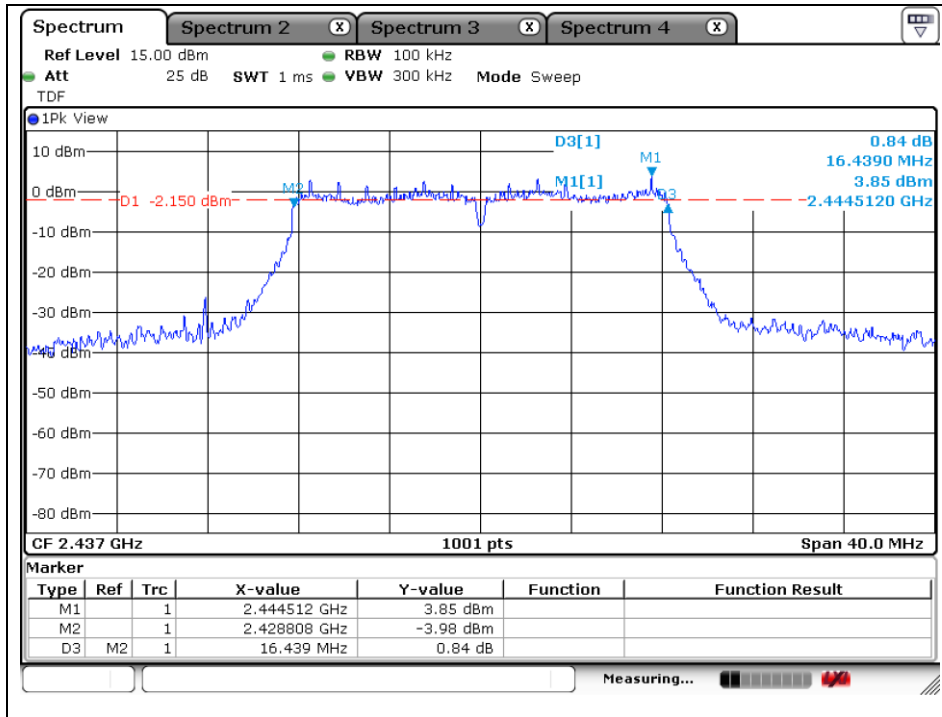

High Channel

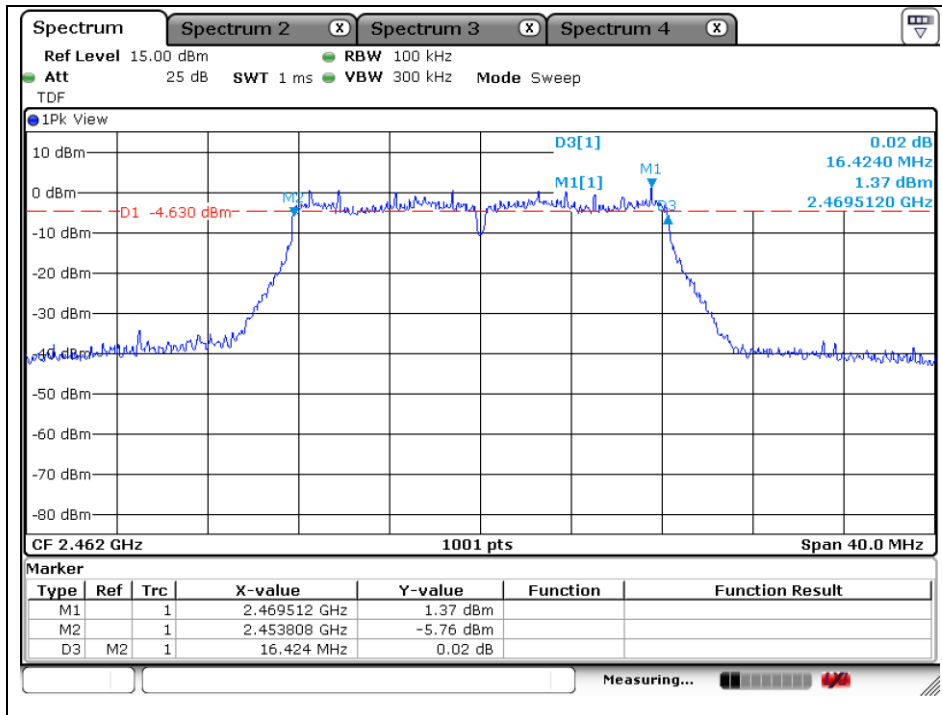

The results shown in this test report refer only to the sample(s) tested unless otherwise stated. This test report cannot be reproduced, except in full, without prior written permission of the Company.

## OFDM: 802.11n\_HT20

### Low Channel

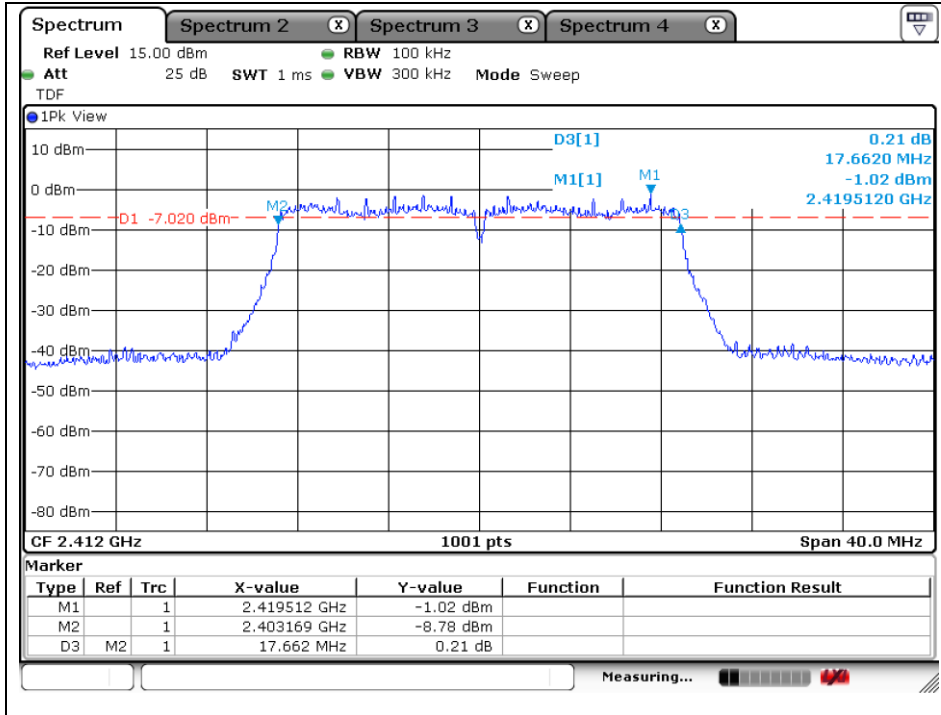

### Middle Channel

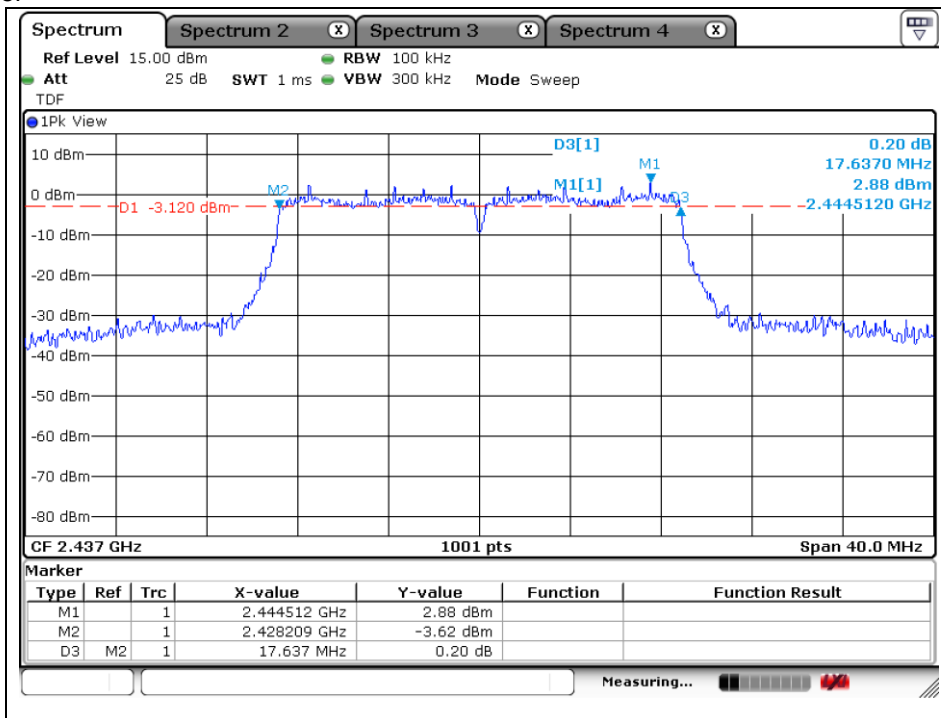

The results shown in this test report refer only to the sample(s) tested unless otherwise stated. This test report cannot be reproduced, except in full, without prior written permission of the Company.

High Channel

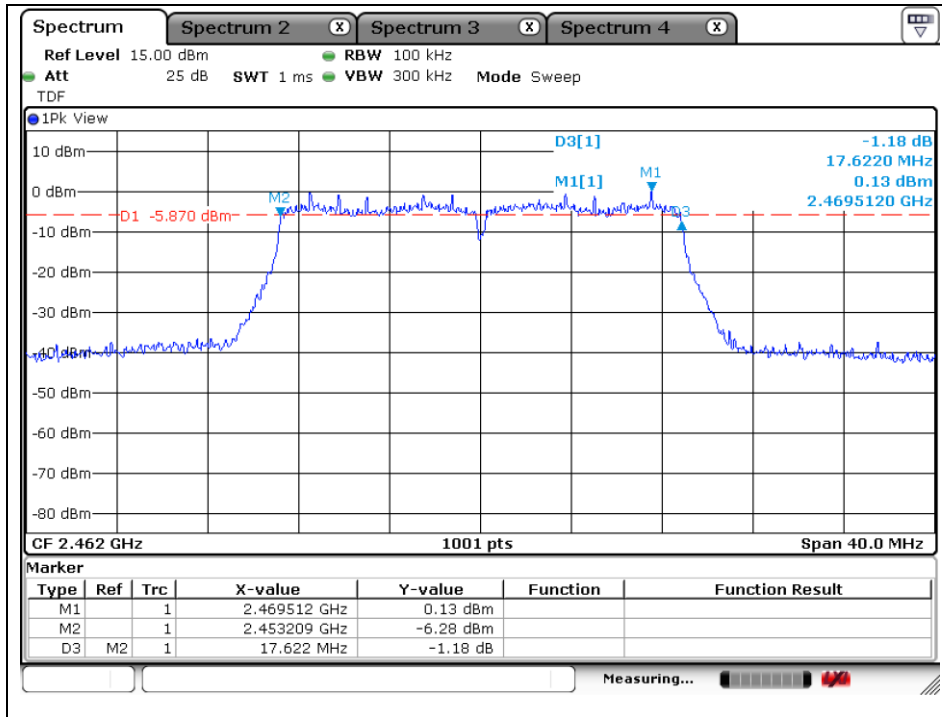

OFDM: 802.11n\_HT40

Low Channel

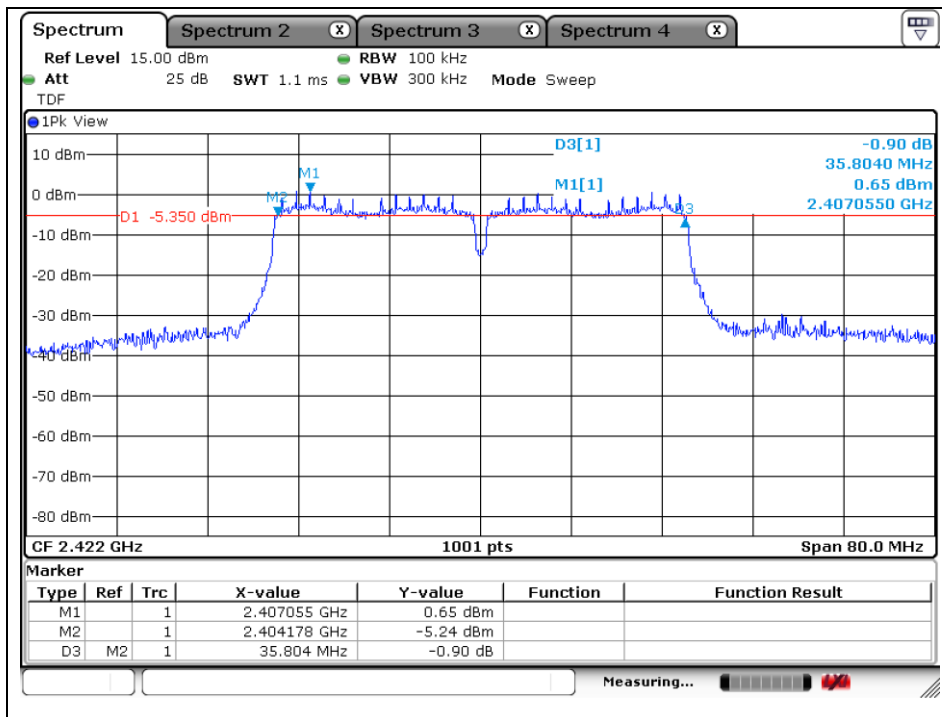

The results shown in this test report refer only to the sample(s) tested unless otherwise stated. This test report cannot be reproduced, except in full, without prior written permission of the Company.

Middle Channel

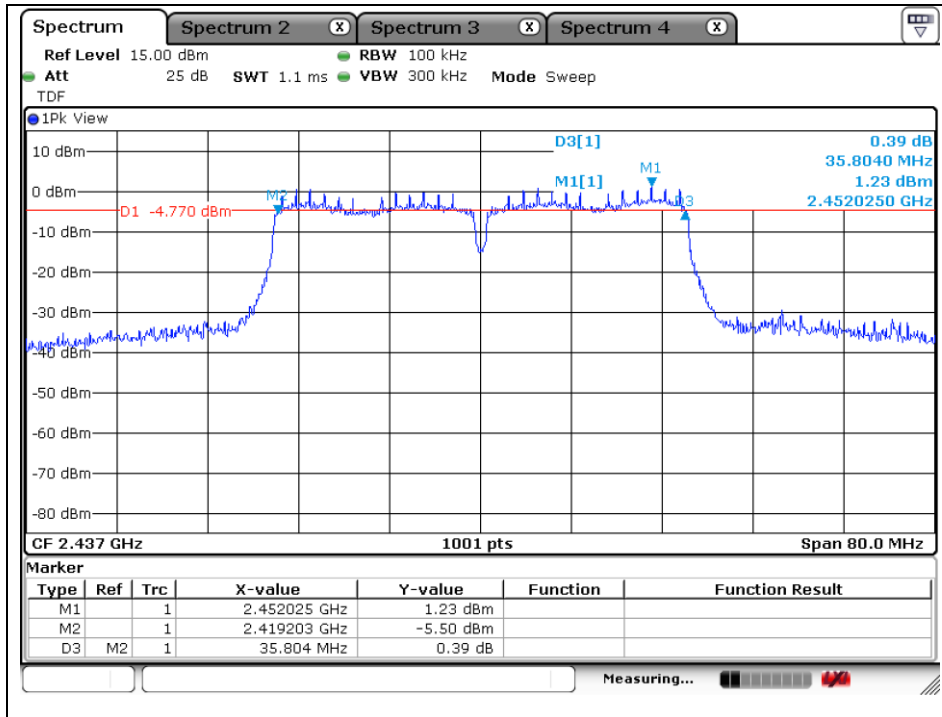

High Channel

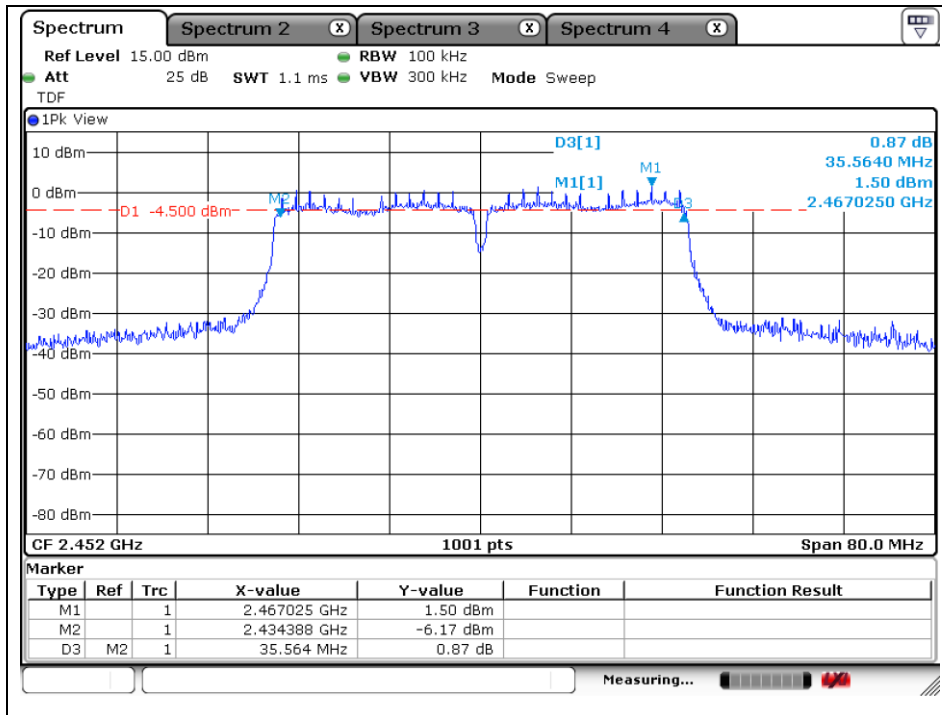

The results shown in this test report refer only to the sample(s) tested unless otherwise stated. This test report cannot be reproduced, except in full, without prior written permission of the Company.



## 4. Maximum Peak Conducted Output Power

### 4.1. Test Setup

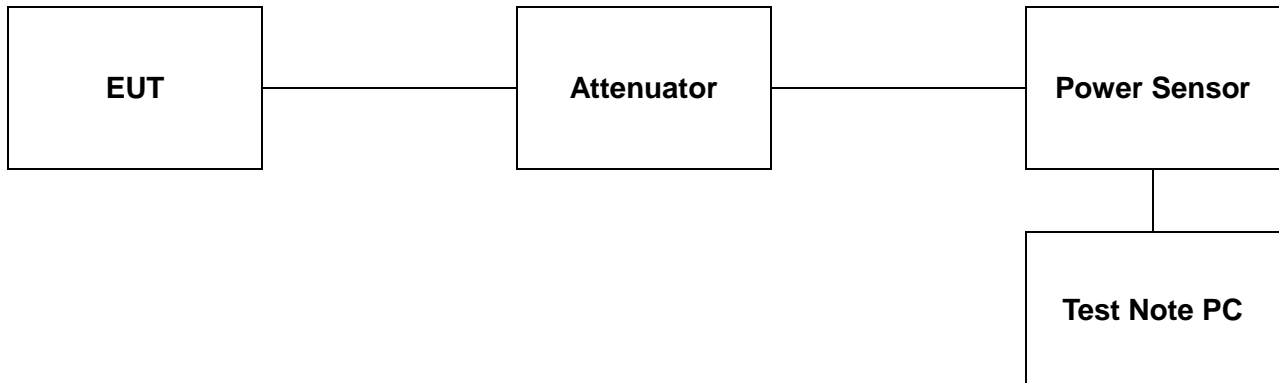

### 4.2. Limit

According to §15.247(b)(3), for systems using digital modulation in the 902-928 MHz, 2 400-2 483.5 MHz, and 5 725-5 850 MHz band : 1 Watt. As an alternative to a peak power measurement, compliance with the one watt limit can be based on a measurement of the maximum conducted output power. Maximum Conducted output Power is defined as the total transmit power delivered to all antennas and antenna elements averaged across all symbols in the signaling alphabet when the transmitter is operating at its maximum power control level. Power must be summed across all antenna elements. The average must not include any intervals during which the transmitter is off or is transmitting at a reduced power level. If multiple modes of operation are possible (e.g., alternative modulation methods), the maximum conducted output power is the highest total transmit power occurring in any mode.

According to §15.247(b)(4), the conducted output power limit specified in paragraph(b) of this section is based on the use of antenna with directional gains that do not exceed 6 dBi. Except as shown in paragraph(c) of this section, if transmitting antenna of directional gain greater than 6 dBi are used, the conducted output power from the intentional radiator shall be reduced below the stated values in paragraph (b)(1), (b)(2), and (b)(3) of this section, as appropriate, by the amount in dB that the directional gain of the antenna exceeds 6 dBi.

### 4.3. Test Procedure

The test follows section 9.1.2 of FCC KDB 558074 D01 v03r05.

#### - Peak power meter method

-The maximum peak conducted output power can be measured using a broad band peak RF power meter. The power meter shall have a video bandwidth that is greater than or equal to the DTS bandwidth and shall utilize a fast-responding diode detector.

#### Test program: (SW name : R&S Power Viewer, Version : 3.2.0)

1. Initially overall offset for attenuator and cable loss is measured per frequency.
2. Measured offset is inserted in test program in advance of measurement for output power.
3. Power for each frequency (channel) and data rate of device is investigated as final result.
4. Final result reported on this section from R&S power viewer program includes with several factors and test program shows only final result.

*The results shown in this test report refer only to the sample(s) tested unless otherwise stated. This test report cannot be reproduced, except in full, without prior written permission of the Company.*

**SGS Korea Co., Ltd. (Gunpo Laboratory)** 4, LS-ro 182beon-gil, Gunpo-si, Gyeonggi-do, Korea, 15807 <http://www.sgsgroup.kr>

#### 4.4. Test Results

Ambient temperature : (23 ± 1) °C

Relative humidity : 47 % R.H.

Mode	Channel	Frequency (MHz)	Data rate (Mbps)	Attenuator + Cable offset (dB)	Ant1	Ant2	Ant1+2	Peak Power Limit (dB m)
					Peak Power Result (dB m)	Peak Power Result (dB m)	Peak Power Result (dB m)	
DSSS (802.11b)	Low	2 412	1	21.47	19.04	19.14	<b>22.10</b>	30
	Middle	2 437	1	21.65	19.05	19.05	22.06	
	High	2 462	1	21.50	19.03	18.73	21.89	
OFDM (802.11g)	Low	2 412	6	21.47	22.03	21.59	24.83	
	Middle	2 437	6	21.65	24.57	24.62	<b>27.61</b>	
	High	2 462	6	21.50	21.59	21.80	24.71	
OFDM (802.11n_HT20)	Low	2 412	MCS8	21.47	20.22	20.19	23.22	
	Middle	2 437	MCS8	21.65	24.57	24.65	<b>27.62</b>	
	High	2 462	MCS8	21.50	20.44	20.34	23.40	
OFDM (802.11n_HT40)	Low	2 422	MCS8	21.47	20.84	20.41	23.64	
	Middle	2 437	MCS8	21.65	24.52	23.91	<b>27.24</b>	
	High	2 452	MCS8	21.50	20.97	20.62	23.81	

#### Remark:

Attenuator and cable offset was compensated in test program (R&S Power Viewer) before measuring.

According to KDB 662911 D01 v02r01, peak power of each port (Ant1 + Ant2) was combined by using below calculation.

Power:  $10\log\{10^{(Ant1\ power/10)}+10^{(Ant2\ power/10)}\}$

*The results shown in this test report refer only to the sample(s) tested unless otherwise stated. This test report cannot be reproduced, except in full, without prior written permission of the Company.*

SGS Korea Co., Ltd. (Gunpo Laboratory) 4, LS-ro 182beon-gil, Gunpo-si, Gyeonggi-do, Korea, 15807 <http://www.sgsgroup.kr>

## 5. Power Spectral Density

### 5.1. Test Setup

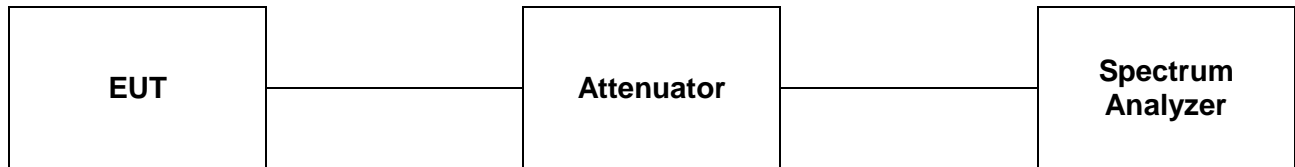

### 5.2. Limit

§15.247(e) For digitally modulated system, the power spectral density conducted from the intentional radiator to the antenna shall not be greater than 8 dB m in any 3 kHz band any time interval of continuous transmission. This power spectral density shall be determined in accordance with the provisions of paragraph (b) of this section. The same method of determining the conducted output power shall be used to determine the power spectral density.

### 5.3. Test Procedure

All data rates and modes were investigated for this test. The full data for the worst case data rate are reported in this section.

The measurements are recorded using the PKPSD measurement procedure in section 10.2 of KDB 558074 D01 v03r05.

- This procedure shall be used if maximum peak conducted output power was used to demonstrate compliance, and is optional if the maximum conducted (average) output power was used to demonstrate compliance.

1. Set analyzer center frequency to DTS channel center frequency.
2. Set the span to at least 1.5 times the DTS channel bandwidth.
3. Set the RBW to :  $3 \text{ kHz} \leq \text{RBW} \leq 100 \text{ kHz}$ .
4. Set the VBW  $\geq 3 \times \text{RBW}$ .
5. Detector = Peak.
6. Sweep time = auto couple.
7. Trace mode = max hold.
8. Allow trace to fully stabilize.
9. Use the peak marker function to determine the maximum amplitude level within the RBW.
10. If measured value exceeds limit, reduce RBW (no less than 3 kHz) and repeat.

*The results shown in this test report refer only to the sample(s) tested unless otherwise stated. This test report cannot be reproduced, except in full, without prior written permission of the Company.*

**SGS Korea Co., Ltd. (Gunpo Laboratory)** 4, LS-ro 182beon-gil, Gunpo-si, Gyeonggi-do, Korea, 15807 <http://www.sgsgroup.kr>

## 5.4. Test Results

Ambient temperature : (23 ± 1) °C

Relative humidity : 47 % R.H.

Operation Mode	Data Rate (Mbps)	Channel	Frequency (MHz)	Ant1	Ant2	Ant1+2	Maximum Limit (dB m)
				Measured PSD (dB m)	Measured PSD (dB m)	PSD Result (dB m)	
DSSS (802.11b)	1	Low	2 412	-4.26	-4.78	-1.50	8
		Middle	2 437	-4.67	-4.82	-1.73	8
		High	2 462	-3.67	-4.47	-1.04	8
OFDM (802.11g)	6	Low	2 412	-16.98	-15.98	-13.44	8
		Middle	2 437	-11.82	-11.85	-8.82	8
		High	2 462	-15.99	-16.43	-13.19	8
OFDM (802.11n_HT20)	MCS8	Low	2 412	-16.73	-17.69	-14.17	8
		Middle	2 437	-9.97	-11.34	-7.59	8
		High	2 462	-16.50	-15.73	-13.09	8
OFDM (802.11n_HT40)	MCS8	Low	2 422	-19.35	-20.23	-16.76	8
		Middle	2 437	-14.17	-14.28	-11.21	8
		High	2 452	-18.45	-19.29	-15.84	8

Note;

According to KDB 662911 D01 v02r01, power spectral density of each port (Ant1 + Ant2) was combined by using below calculation.

PSD:  $10\log\{10^{Ant1\ psd/10}+10^{Ant2\ psd/10}\}$

The results shown in this test report refer only to the sample(s) tested unless otherwise stated. This test report cannot be reproduced, except in full, without prior written permission of the Company.

SGS Korea Co., Ltd. (Gunpo Laboratory) 4, LS-ro 182beon-gil, Gunpo-si, Gyeonggi-do, Korea, 15807 <http://www.sgsgroup.kr>

## DSSS: 802.11b - ANT1

### Low Channel

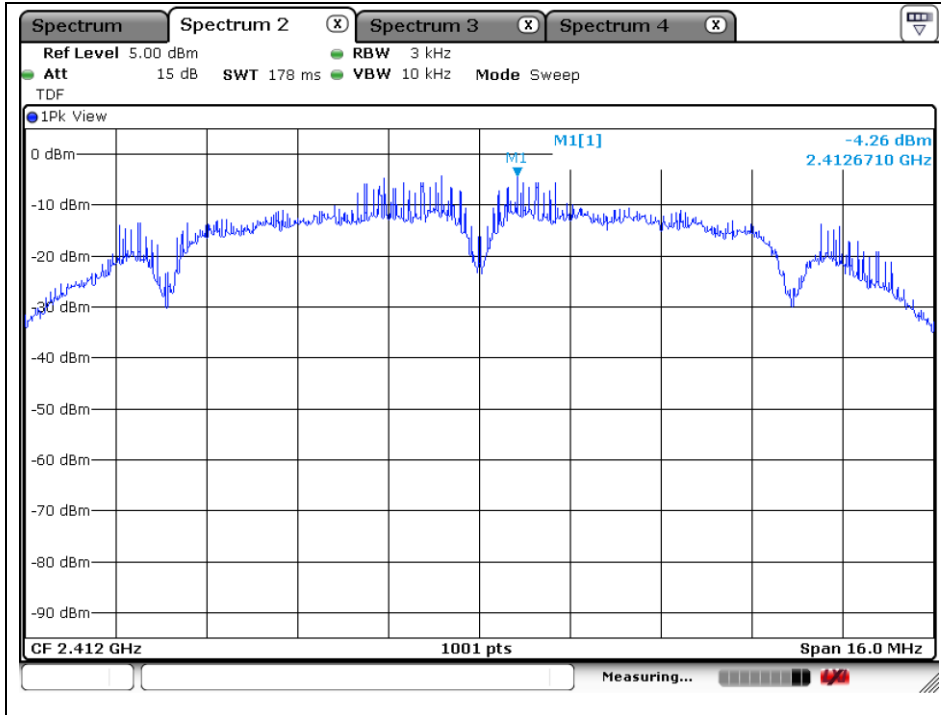

### Middle Channel

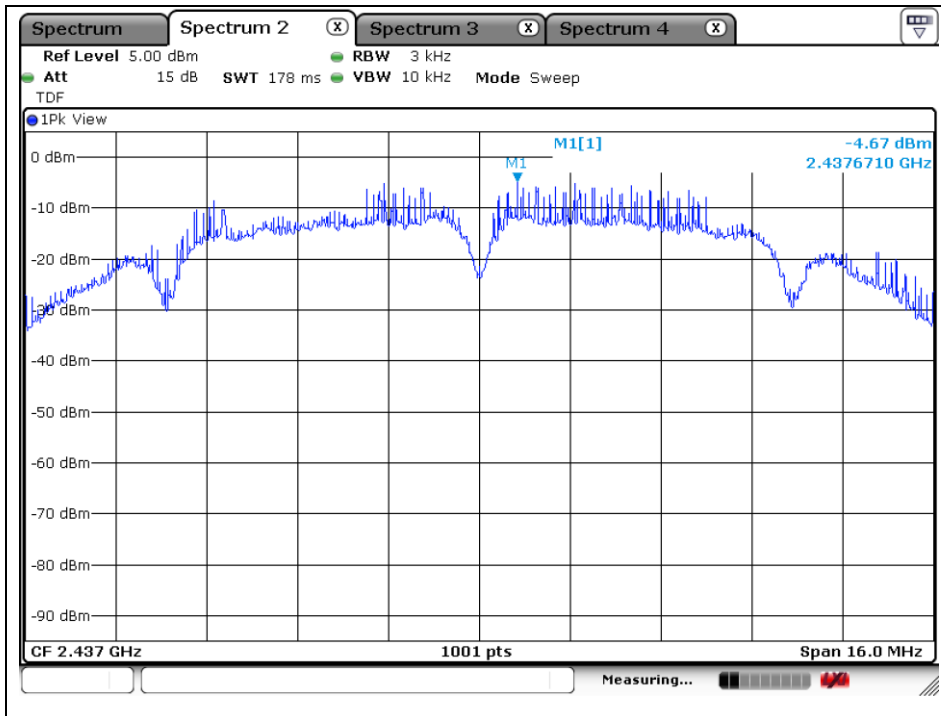

The results shown in this test report refer only to the sample(s) tested unless otherwise stated. This test report cannot be reproduced, except in full, without prior written permission of the Company.

High Channel

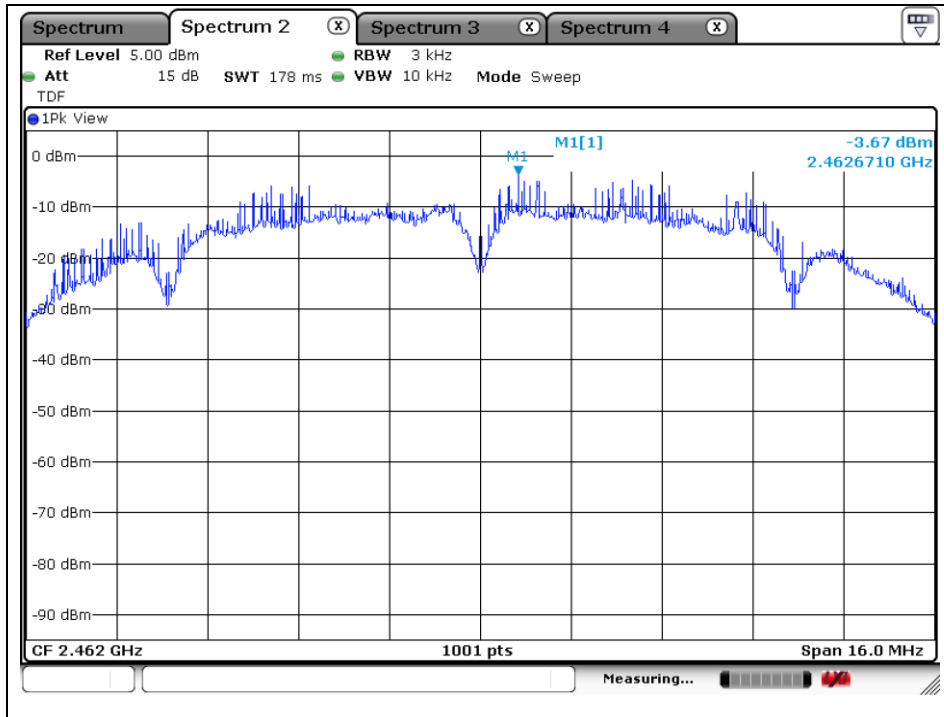

DSSS: 802.11b - ANT2

Low Channel

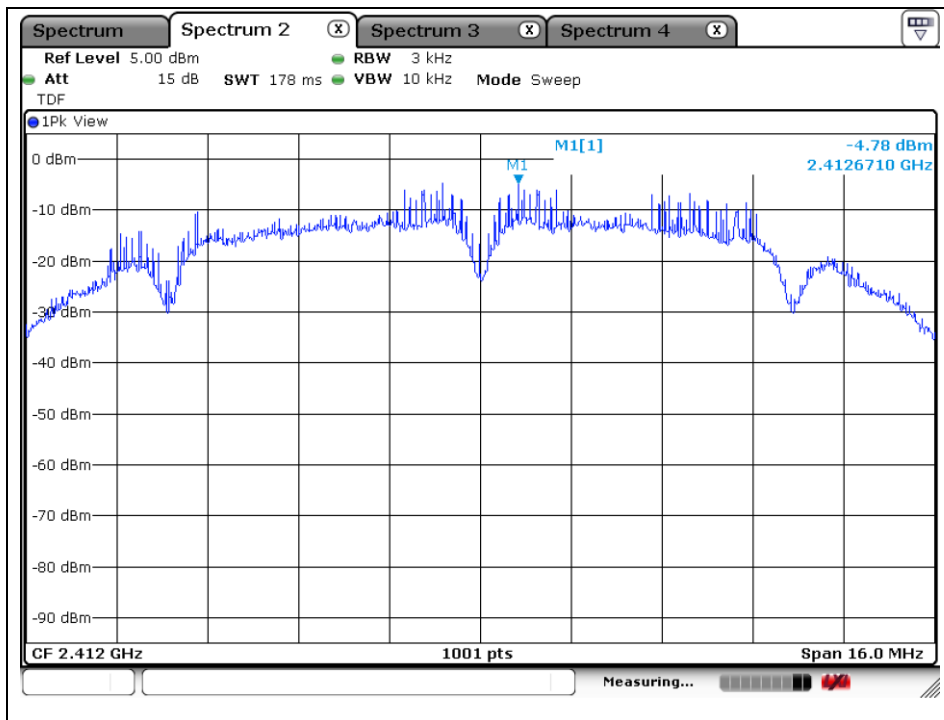

The results shown in this test report refer only to the sample(s) tested unless otherwise stated. This test report cannot be reproduced, except in full, without prior written permission of the Company.

Middle Channel

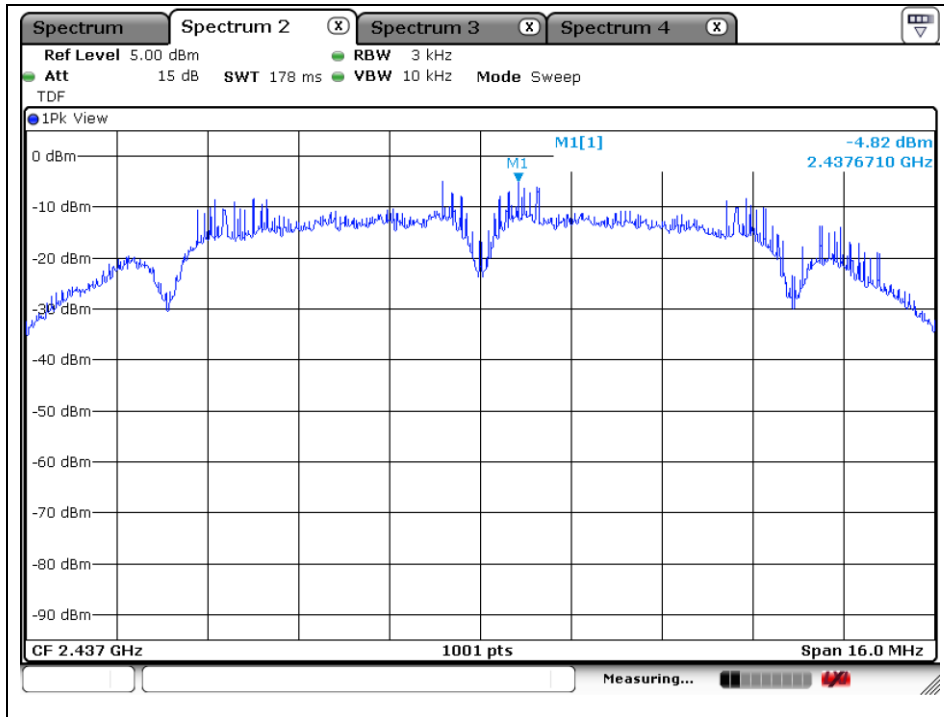

High Channel

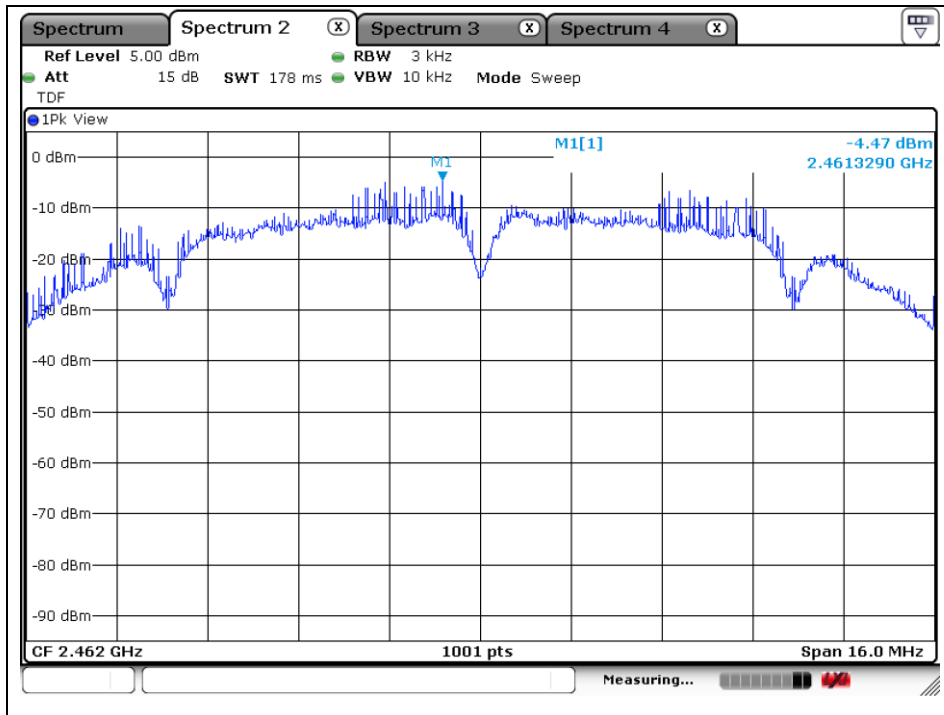

The results shown in this test report refer only to the sample(s) tested unless otherwise stated. This test report cannot be reproduced, except in full, without prior written permission of the Company.

## OFDM: 802.11g - ANT1

### Low Channel

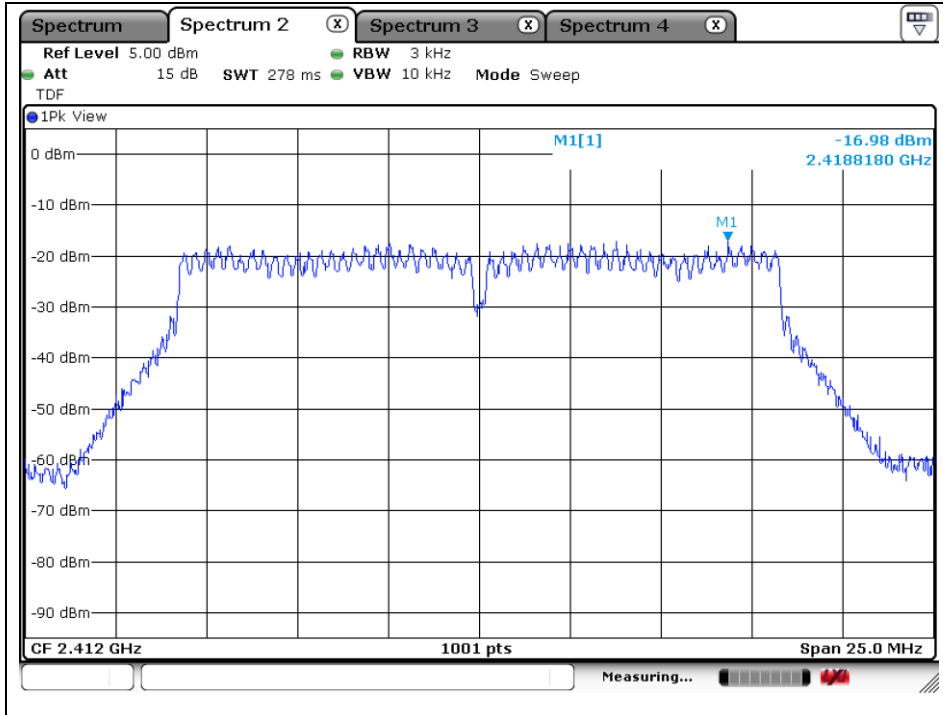

### Middle Channel

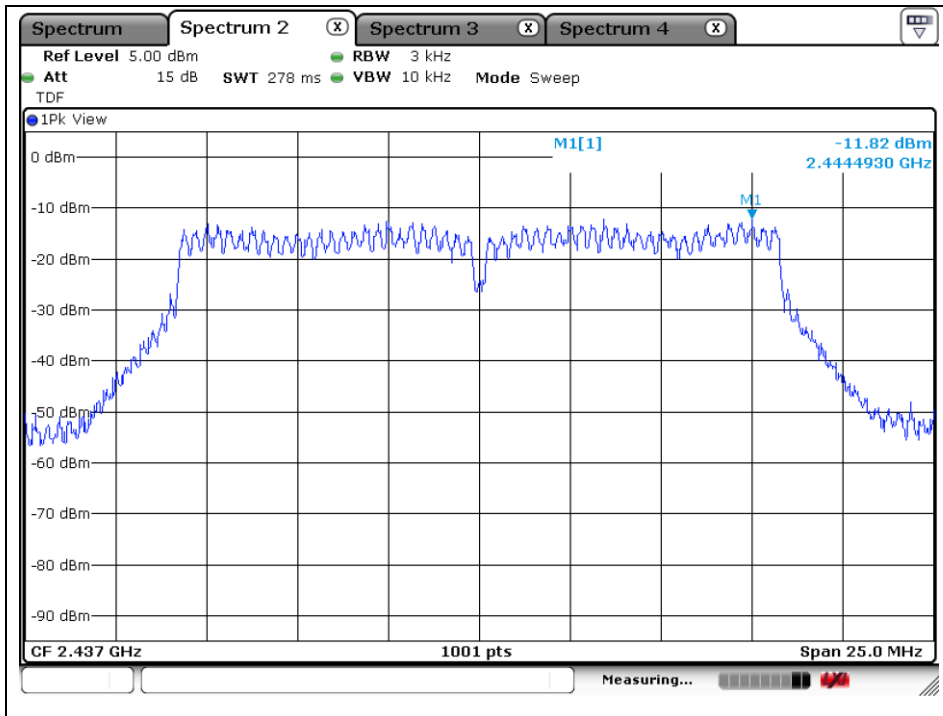

The results shown in this test report refer only to the sample(s) tested unless otherwise stated. This test report cannot be reproduced, except in full, without prior written permission of the Company.



High Channel

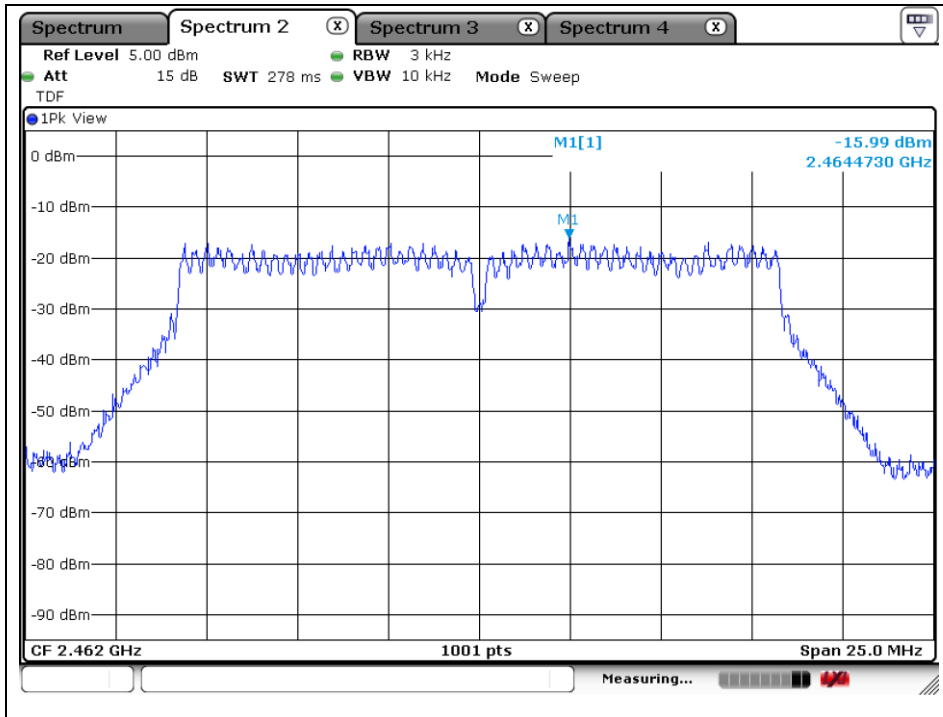

OFDM: 802.11g - ANT2

Low Channel

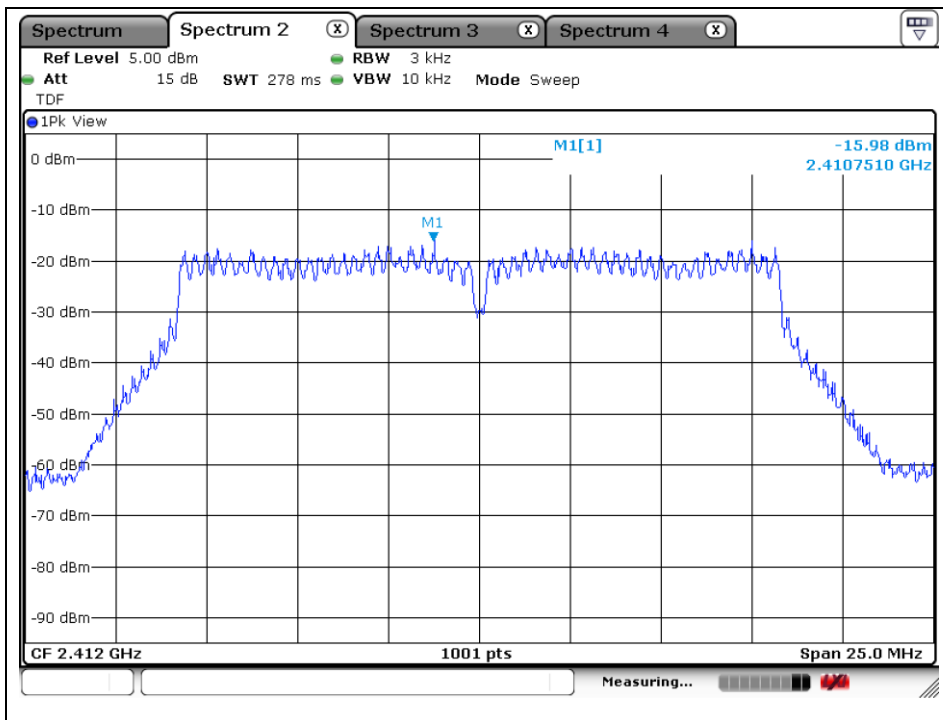

The results shown in this test report refer only to the sample(s) tested unless otherwise stated. This test report cannot be reproduced, except in full, without prior written permission of the Company.

Middle Channel

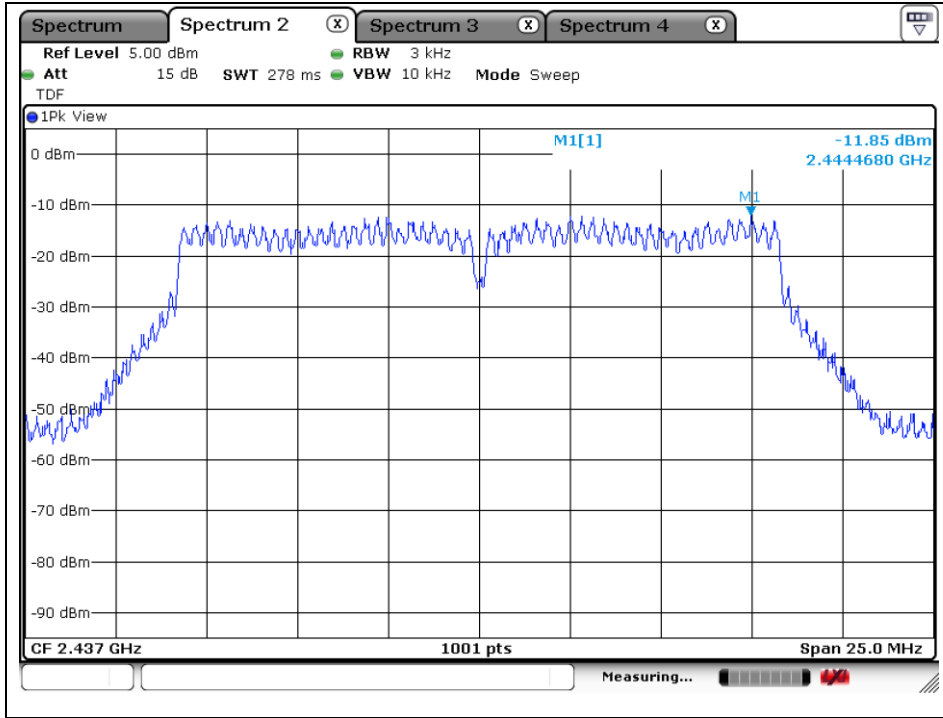

High Channel

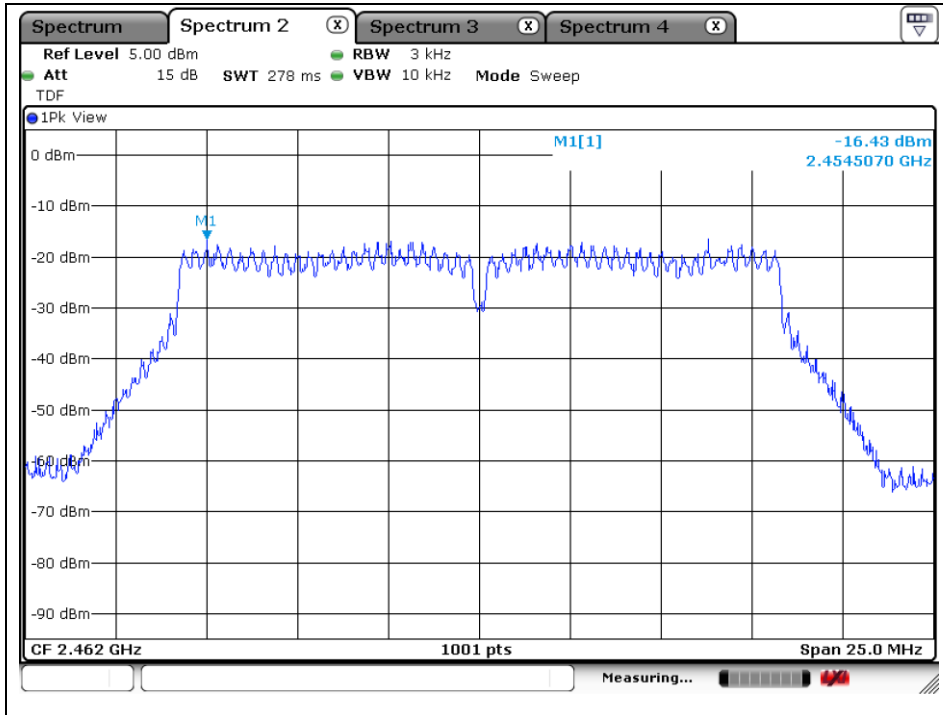

The results shown in this test report refer only to the sample(s) tested unless otherwise stated. This test report cannot be reproduced, except in full, without prior written permission of the Company.

## OFDM: 802.11n\_HT20 - Ant1

### Low Channel

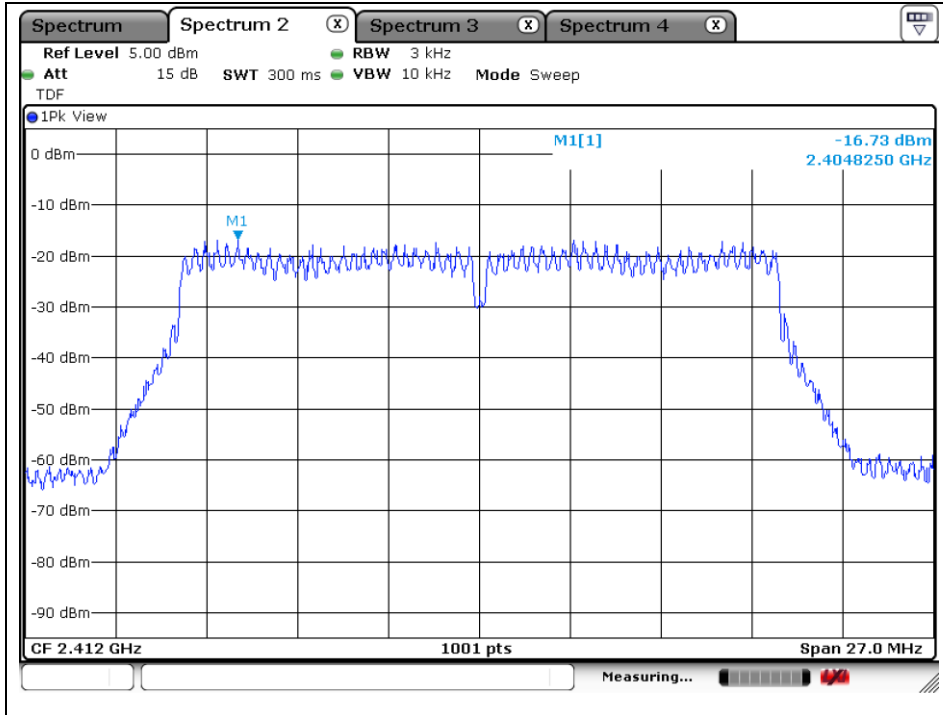

### Middle Channel

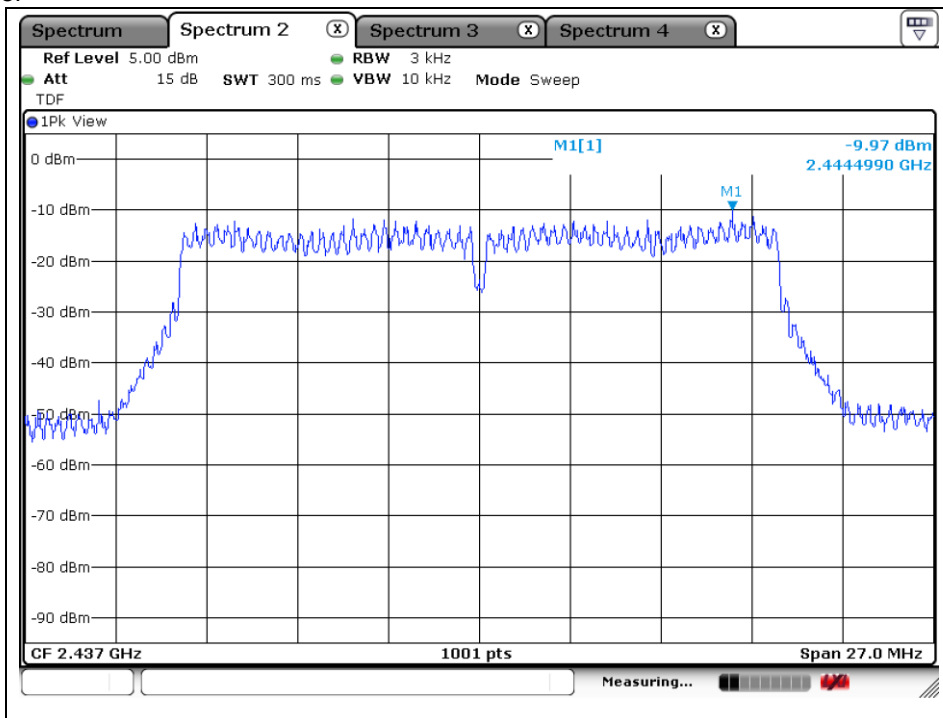

The results shown in this test report refer only to the sample(s) tested unless otherwise stated. This test report cannot be reproduced, except in full, without prior written permission of the Company.

SGS Korea Co., Ltd. (Gunpo Laboratory) 4, LS-ro 182beon-gil, Gunpo-si, Gyeonggi-do, Korea, 15807 <http://www.sgsgroup.kr>

High Channel

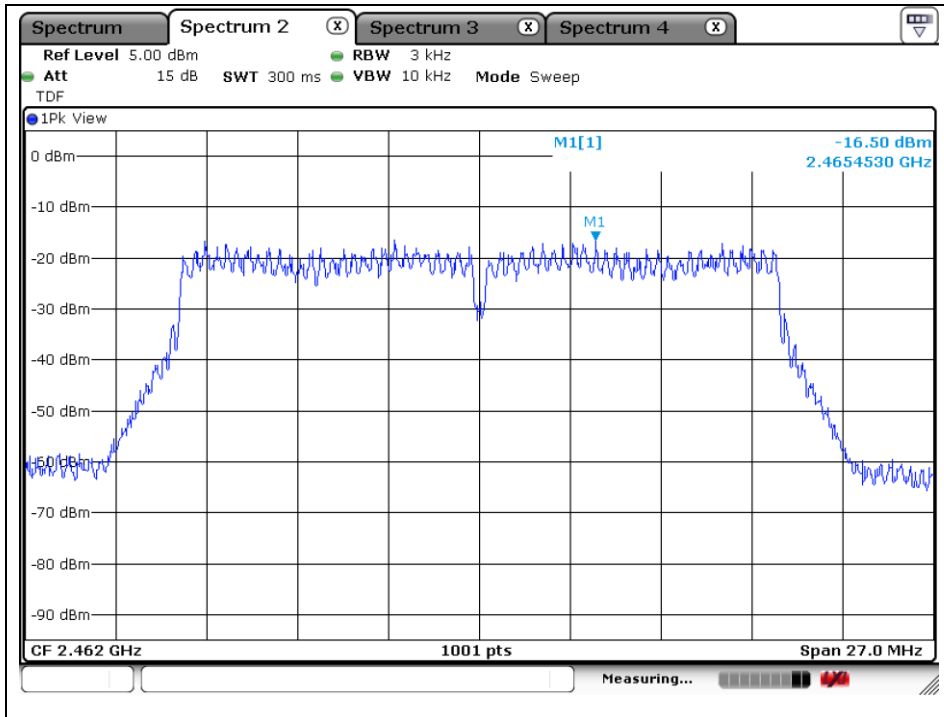

OFDM: 802.11n\_HT20 - Ant2

Low Channel

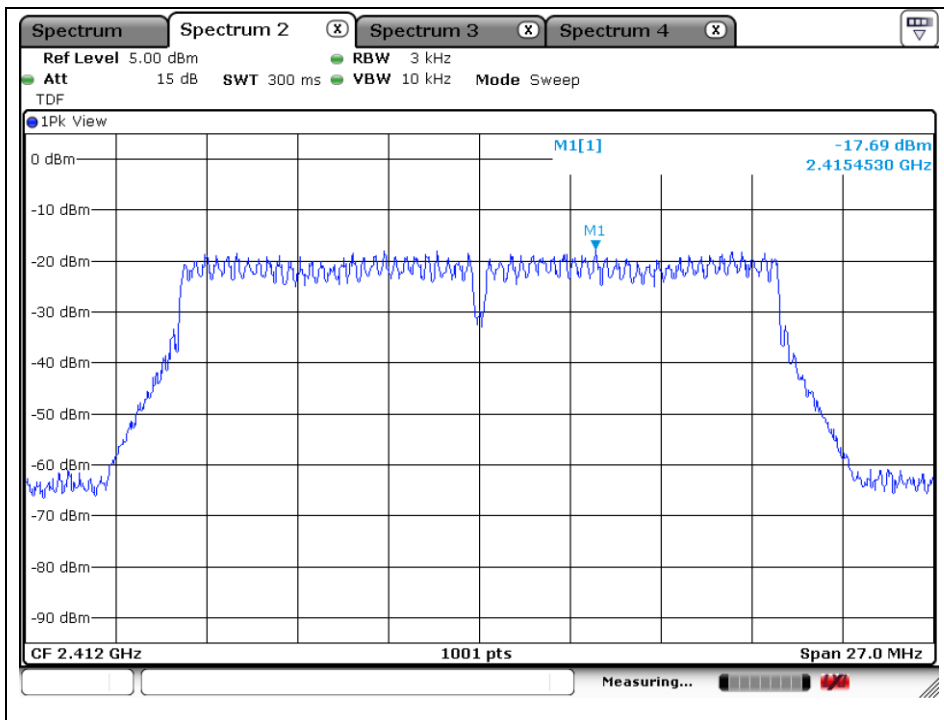

The results shown in this test report refer only to the sample(s) tested unless otherwise stated. This test report cannot be reproduced, except in full, without prior written permission of the Company.

Middle Channel

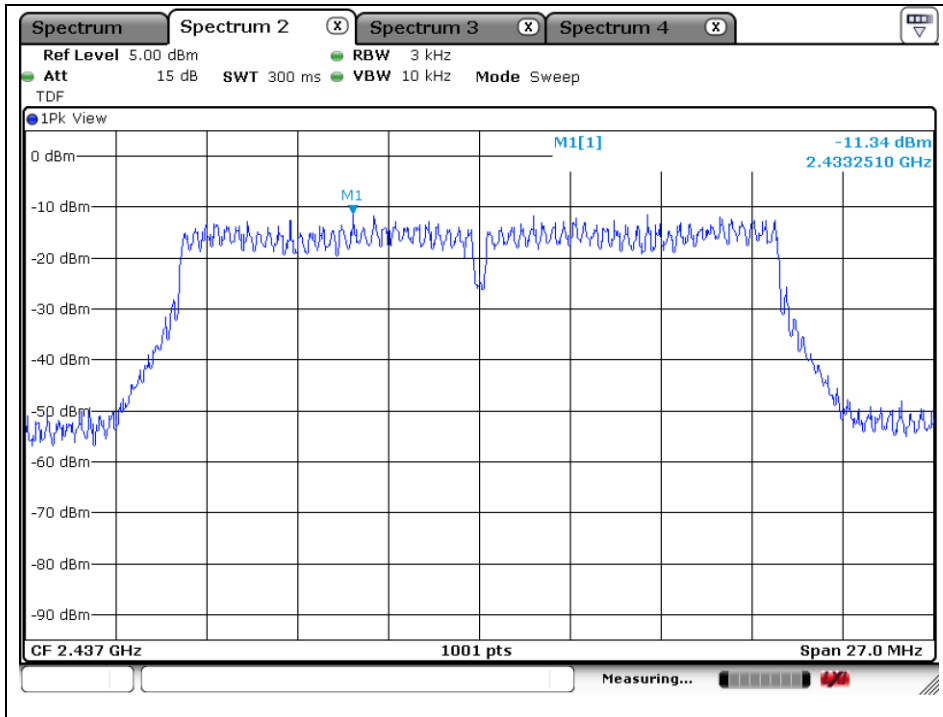

High Channel

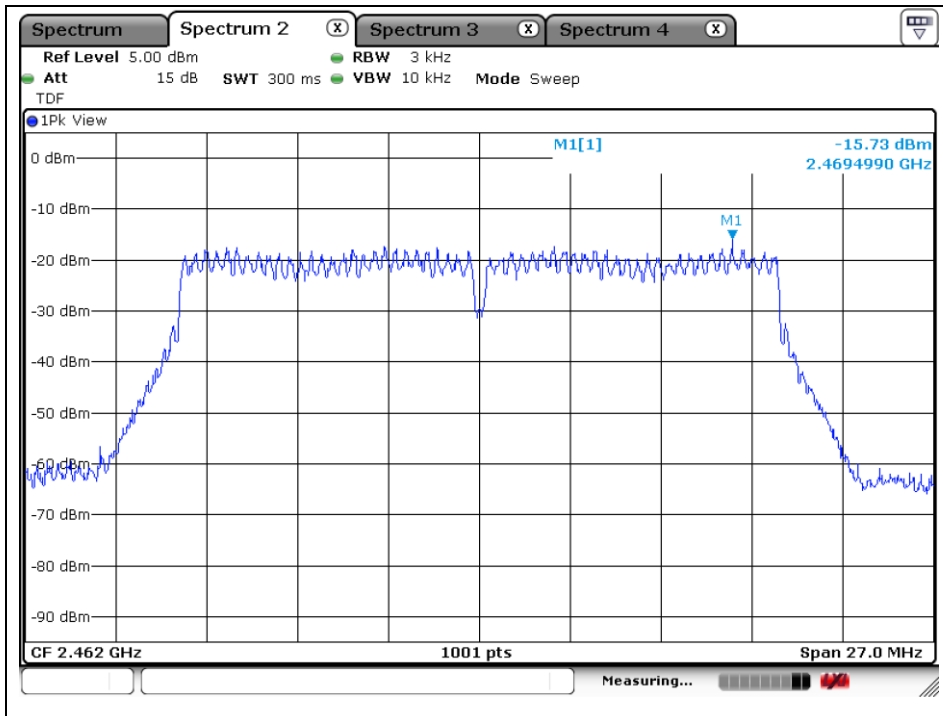

The results shown in this test report refer only to the sample(s) tested unless otherwise stated. This test report cannot be reproduced, except in full, without prior written permission of the Company.

## OFDM: 802.11n\_HT40 - Ant1

### Low Channel

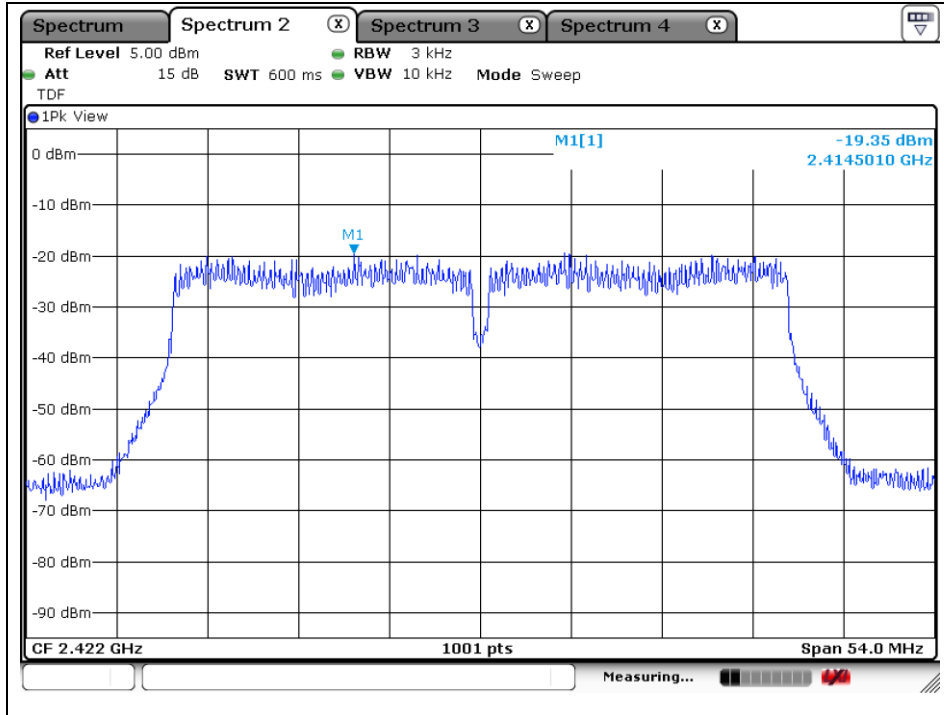

### Middle Channel

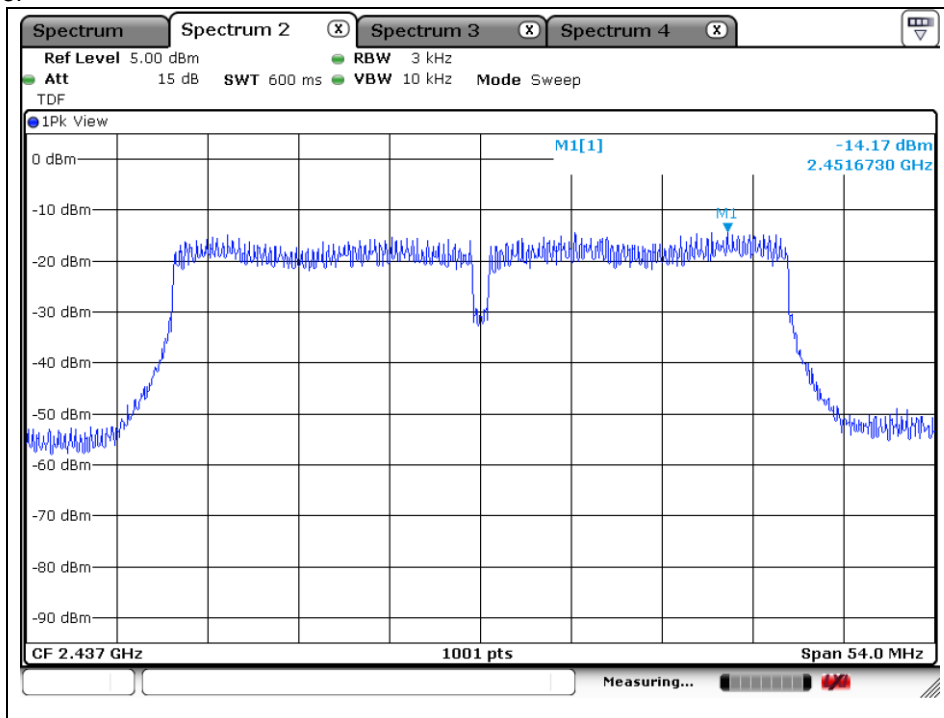

The results shown in this test report refer only to the sample(s) tested unless otherwise stated. This test report cannot be reproduced, except in full, without prior written permission of the Company.

High Channel

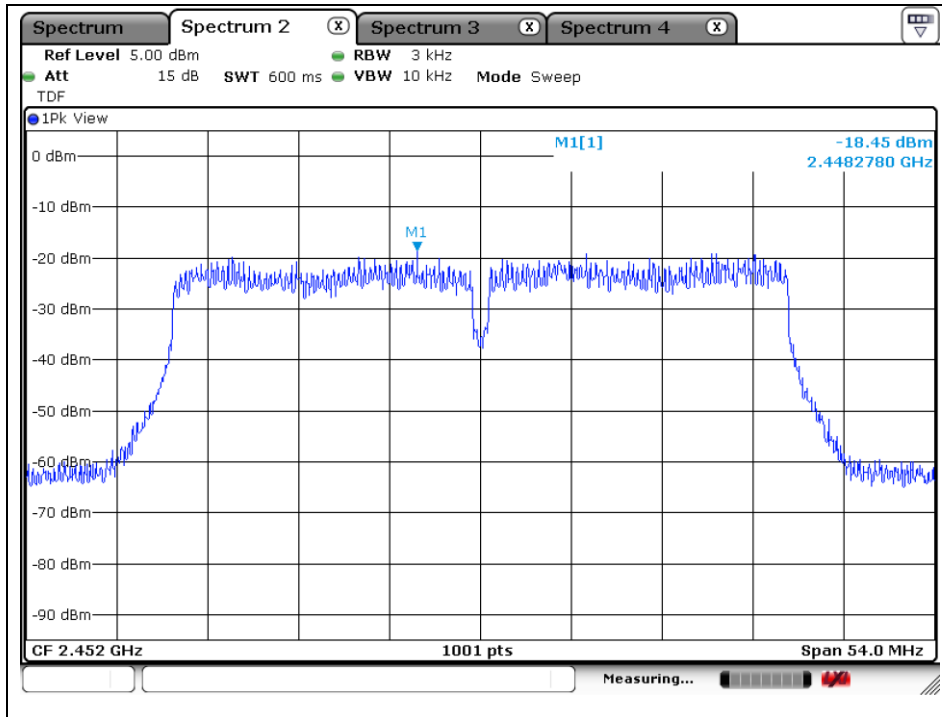

OFDM: 802.11n\_HT40 - Ant2

Low Channel

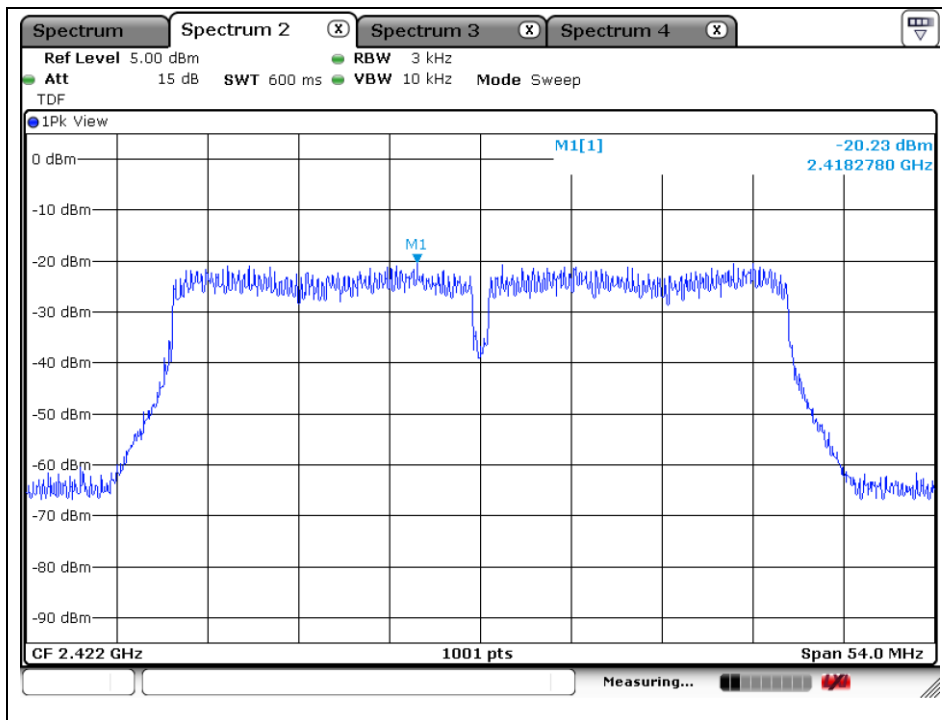

The results shown in this test report refer only to the sample(s) tested unless otherwise stated. This test report cannot be reproduced, except in full, without prior written permission of the Company.

Middle Channel

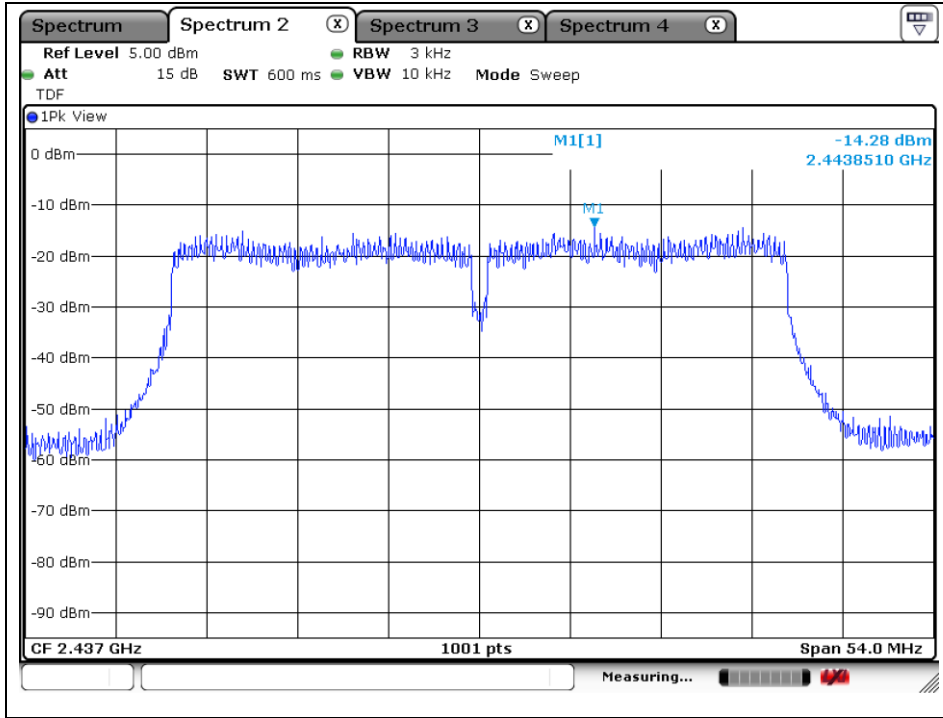

High Channel

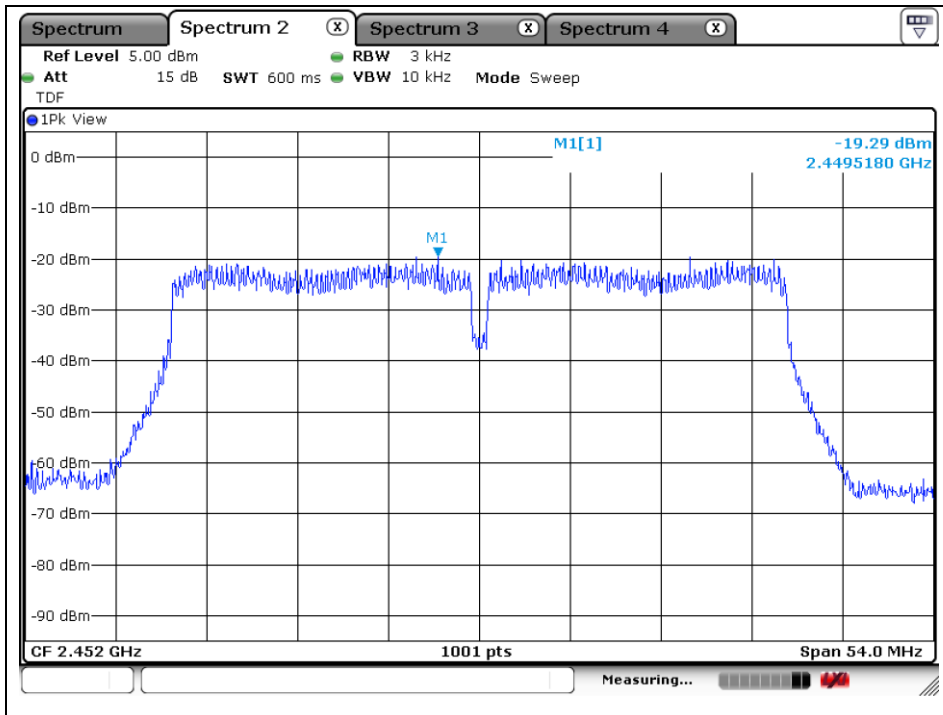

The results shown in this test report refer only to the sample(s) tested unless otherwise stated. This test report cannot be reproduced, except in full, without prior written permission of the Company.



## 6. AC Power Line Conducted Emission

### 6.1. Test Setup

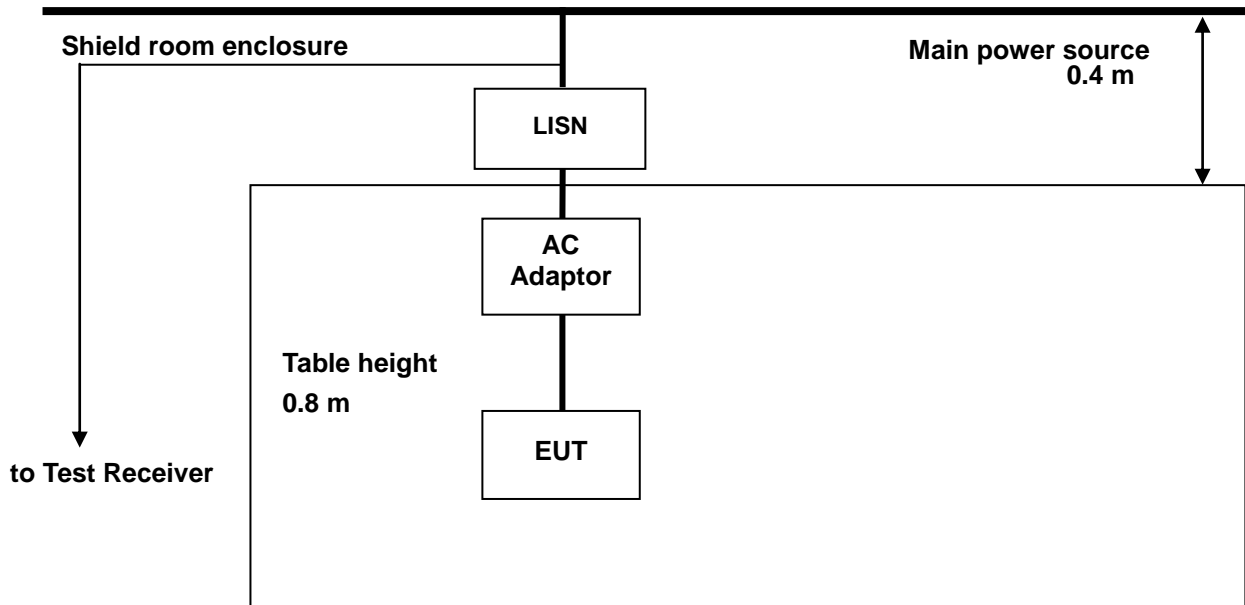

### 6.2. Limit

According to §15.207(a) for an intentional radiator that is designed to be connected to the public utility (AC) power line, the radio frequency voltage that is conducted back onto the AC power line on any frequency or frequencies, within the band 150 kHz to 30 MHz, shall not exceed the limits in the following table, as measured using a 50  $\mu$ H / 50 ohm line impedance stabilization network (LISN).

Compliance with the provision of this paragraph shall be on the measurement of the radio frequency voltage between each power line and ground at the power terminal. The lower applies at the boundary between the frequency ranges.

Frequency of Emission (MHz)	Conducted limit (dB $\mu$ V)	
	Quasi-peak	Average
0.15 – 0.50	66 - 56*	56 - 46*
0.50 – 5.00	56	46
5.00 – 30.0	60	50

\* Decreases with the logarithm of the frequency.

The results shown in this test report refer only to the sample(s) tested unless otherwise stated. This test report cannot be reproduced, except in full, without prior written permission of the Company.

SGS Korea Co., Ltd. (Gunpo Laboratory) 4, LS-ro 182beon-gil, Gunpo-si, Gyeonggi-do, Korea, 15807 <http://www.sgsgroup.kr>

---

### 6.3. Test Procedures

All data rates and modes were investigated for this test. The full data for the worst case data rate are reported in this section.

AC line conducted emissions from the EUT were measured according to the dictates of ANSI C63.10-2013

1. The test procedure is performed in a 6.5 m × 3.6 m × 3.6 m (L × W × H) shielded room. The EUT along with its peripherals were placed on a 1.0 m (W) × 1.5 m (L) and 0.8 m in height wooden table and the EUT was adjusted to maintain a 0.4 meter space from a vertical reference plane.
2. The EUT was connected to power mains through a line impedance stabilization network (LISN) which provides 50 ohm coupling impedance for measuring instrument and the chassis ground was bounded to the horizontal ground plane of shielded room.
3. The excess power cable between the EUT and the LISN was bundled. All connecting cables of EUT were moved to find the maximum emission.

---

*The results shown in this test report refer only to the sample(s) tested unless otherwise stated. This test report cannot be reproduced, except in full, without prior written permission of the Company.*

**SGS Korea Co., Ltd. (Gunpo Laboratory)** 4, LS-ro 182beon-gil, Gunpo-si, Gyeonggi-do, Korea, 15807 <http://www.sgsgroup.kr>

## 6.4. Test Results

The following table shows the highest levels of conducted emissions on both phase of Hot and Neutral line

Ambient temperature : (23 ± 1) °C  
 Relative humidity : 47 % R.H.  
  
 Frequency range : 0.15 MHz – 30 MHz  
 Measured Bandwidth : 9 kHz

FREQ. (MHz)	LEVEL(dB $\mu$ V)		LINE	LIMIT(dB $\mu$ V)		MARGIN(dB)	
	Q-Peak	Average		Q-Peak	Average	Q-Peak	Average
0.17	54.64	35.69	N	64.96	54.96	10.32	19.27
0.20	50.05	34.81	N	63.61	53.61	13.56	18.80
0.56	27.61	23.03	N	56.00	46.00	28.39	22.97
2.45	25.61	21.37	N	56.00	46.00	30.39	24.63
5.28	23.66	19.18	N	60.00	50.00	36.34	30.82
11.81	31.67	27.45	N	60.00	50.00	28.33	22.55
0.17	54.11	36.78	H	64.96	54.96	10.85	18.18
0.20	53.39	34.90	H	63.61	53.61	10.22	18.71
0.55	23.25	16.40	H	56.00	46.00	32.75	29.60
2.19	24.99	20.86	H	56.00	46.00	31.01	25.14
3.91	24.31	15.94	H	56.00	46.00	31.69	30.06
11.86	24.12	19.93	H	60.00	50.00	35.88	30.07

Remark;

- Line ( H ): Hot, Line ( N ): Neutral.
- All modes of operation were investigated and the worst-case emissions were reported using **11n HT20 Mode, MCS8, Middle channel.**
- Traces shown in plot mad using a peak detector and average detector.
- The limit for Class B device(s) from 150 kHz to 30 MHz are specified in Section of the Title 47 CFR.
- Deviations to the Specifications: None.

*The results shown in this test report refer only to the sample(s) tested unless otherwise stated. This test report cannot be reproduced, except in full, without prior written permission of the Company.*

## Plots of Conducted Power line

Test mode: (Neutral)

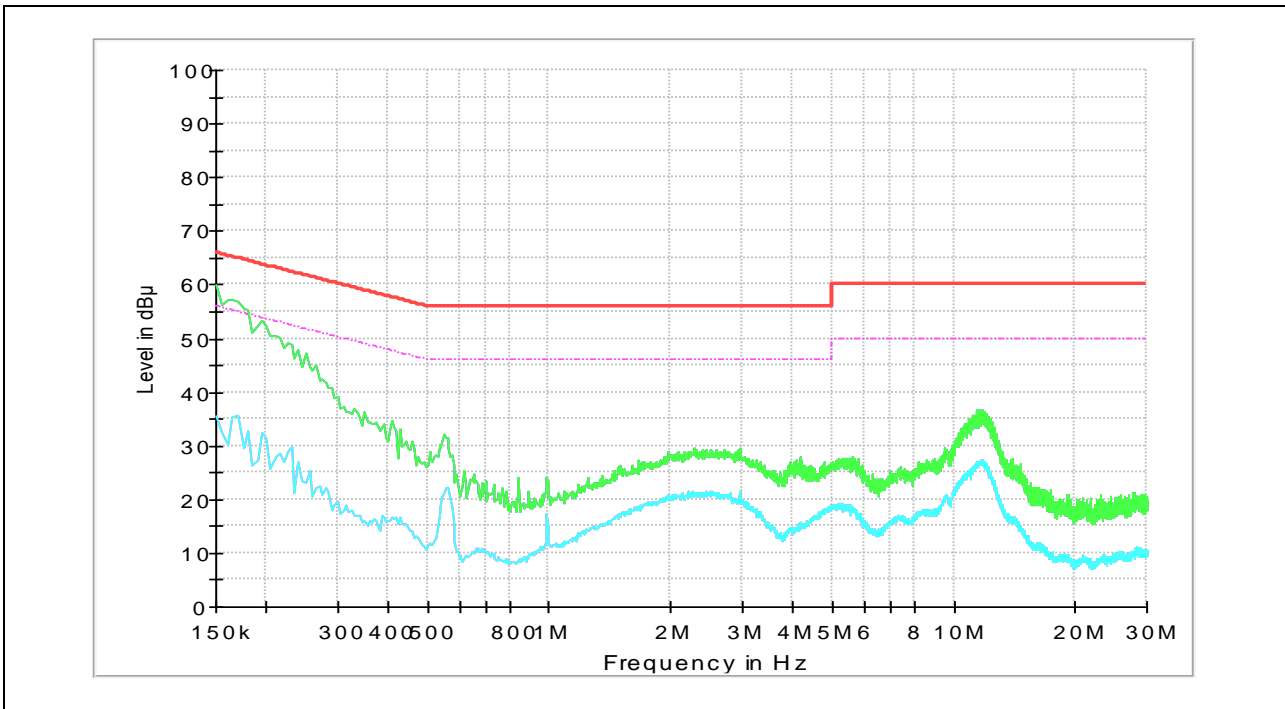

Test mode: (Hot)

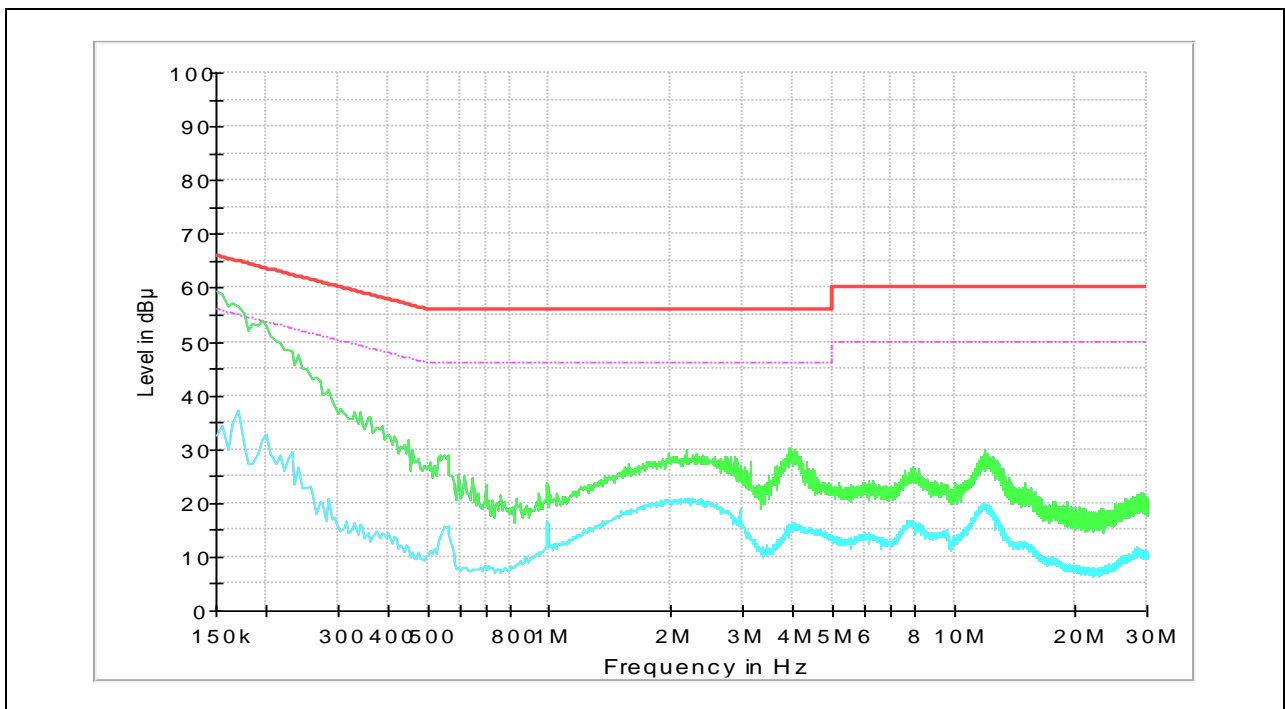

The results shown in this test report refer only to the sample(s) tested unless otherwise stated. This test report cannot be reproduced, except in full, without prior written permission of the Company.

SGS Korea Co., Ltd. (Gunpo Laboratory) 4, LS-ro 182beon-gil, Gunpo-si, Gyeonggi-do, Korea, 15807 <http://www.sgsgroup.kr>

## 7. Antenna Requirement

### 7.1. Standard Applicable

For intentional device, according to FCC 47 CFR Section §15.203, an intentional radiator shall be designed to ensure that no antenna other than that furnished by the responsible party shall be used with the device. And according to FCC 47 CFR Section §15.247 (b) if transmitting antennas of directional gain greater than 6 dB i are used, the power shall be reduced by the amount in dB that the gain of the antenna exceeds 6 dB i.

### 7.2. Antenna Connected Construction

Antenna used in this product is Planer inverted F Antenna and peak max gain of antenna as below.

<b>Band</b>	<b>2 402 MHz – 2 483.5 MHz</b>
<b>Mode</b>	<b>11b/g/n_HT20, HT40</b>
<b>Ant1 Gain</b>	1.20 dB i
<b>Ant2 Gain</b>	1.94 dB i

Unequal antenna gains, with equal transmit powers. For antenna gains given by  $G_1, G_2, \dots, G_N$  dB i

(i) If transmit signals are correlated, then

Directional gain =  $10 \log[(10^{G_1/20} + 10^{G_2/20} + \dots + 10^{G_N/20})^2 / N_{ANT}]$  dB i [Note the “20”s in the denominator of each exponent and the square of the sum of terms; the object is to combine the signal levels coherently.]

Directional Gain = 4.59 dB i

**- End of the Test Report -**

*The results shown in this test report refer only to the sample(s) tested unless otherwise stated. This test report cannot be reproduced, except in full, without prior written permission of the Company.*

**SGS Korea Co., Ltd. (Gunpo Laboratory)** 4, LS-ro 182beon-gil, Gunpo-si, Gyeonggi-do, Korea, 15807 <http://www.sgsgroup.kr>