

- 11a

5 180 MHz(6 Mbps)

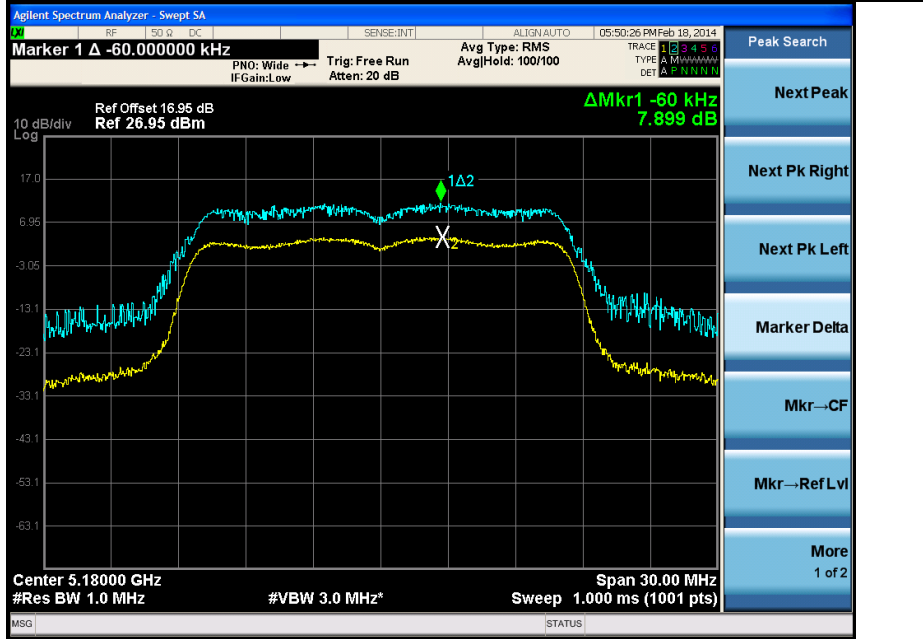

5 180 MHz(9 Mbps)

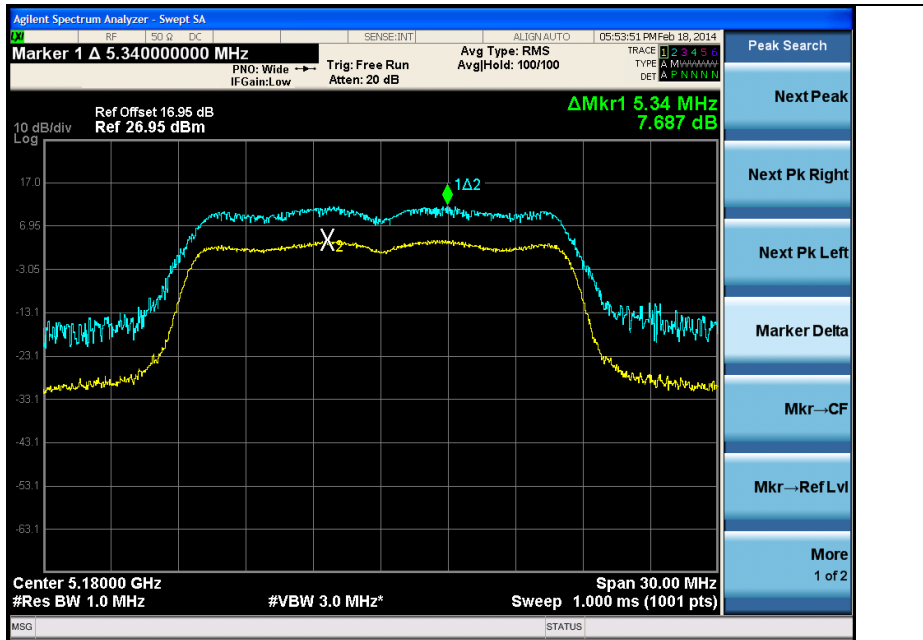

The results shown in this test report refer only to the sample(s) tested unless otherwise stated. This test report cannot be reproduced, except in full, without prior written permission of the Company.

5 180 MHz(12 Mbps)

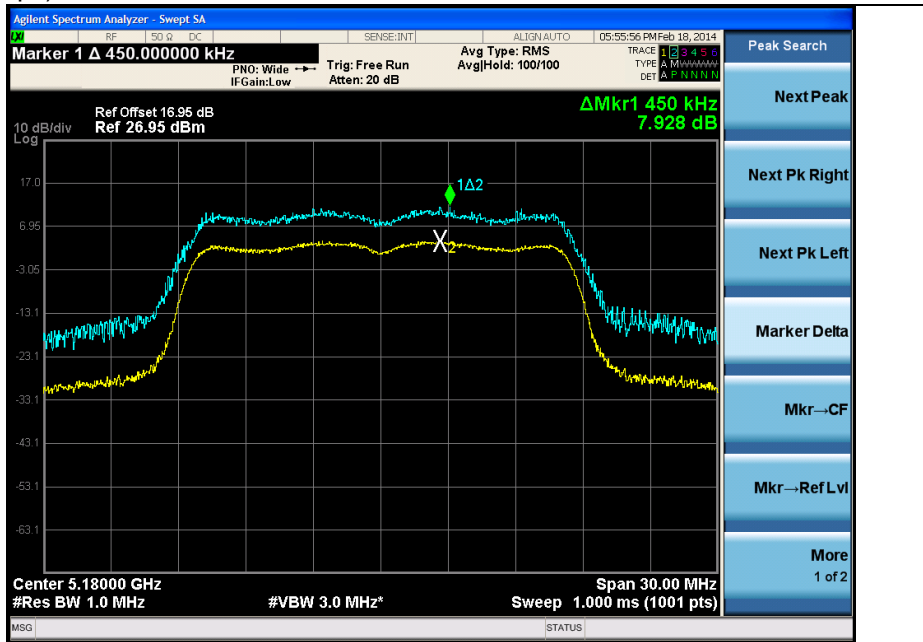

5 180 MHz(18 Mbps)



The results shown in this test report refer only to the sample(s) tested unless otherwise stated. This test report cannot be reproduced, except in full, without prior written permission of the Company.

5 180 MHz(24 Mbps)

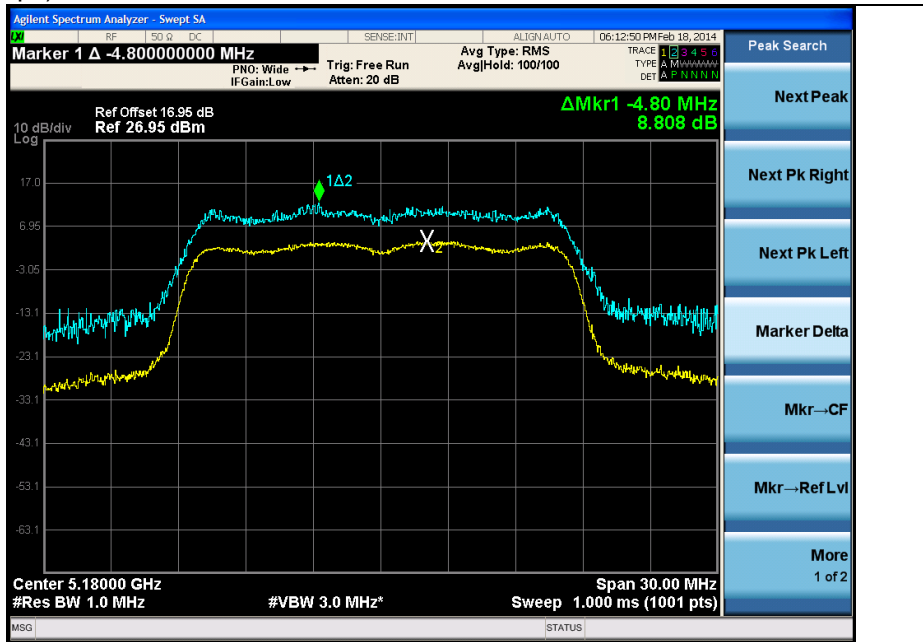

5 180 MHz(36 Mbps)

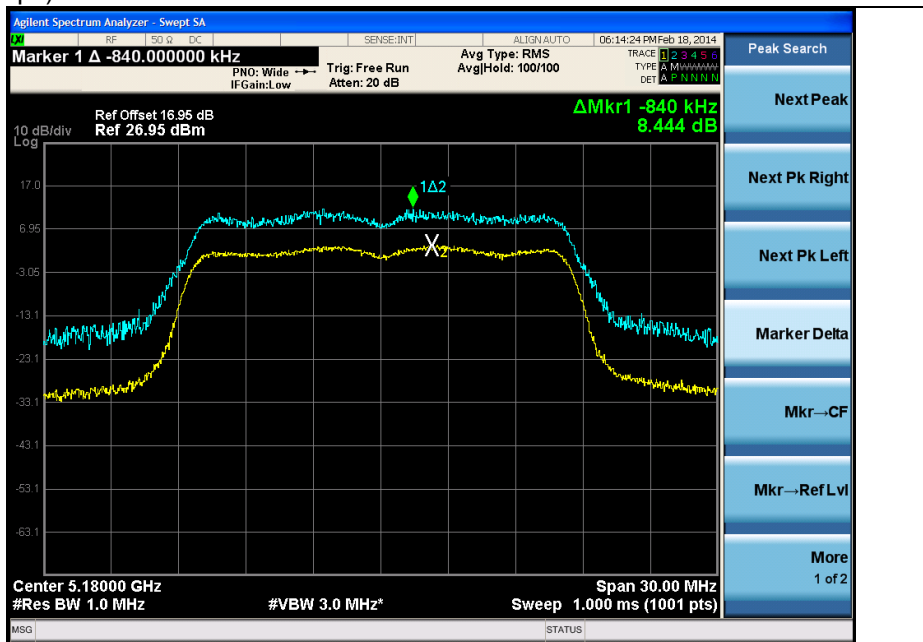

The results shown in this test report refer only to the sample(s) tested unless otherwise stated. This test report cannot be reproduced, except in full, without prior written permission of the Company.

5 180 MHz(48 Mbps)

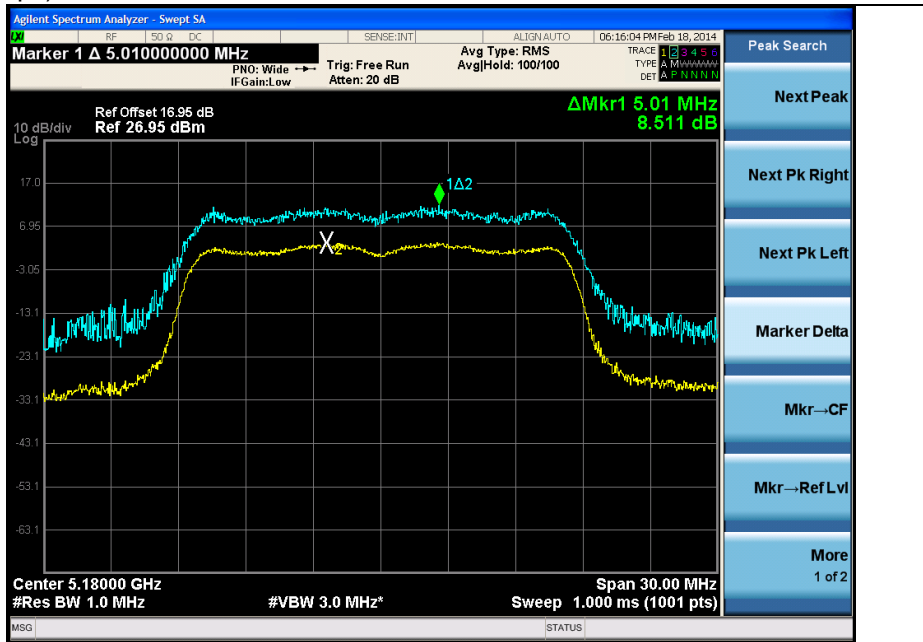

5 180 MHz(54 Mbps)

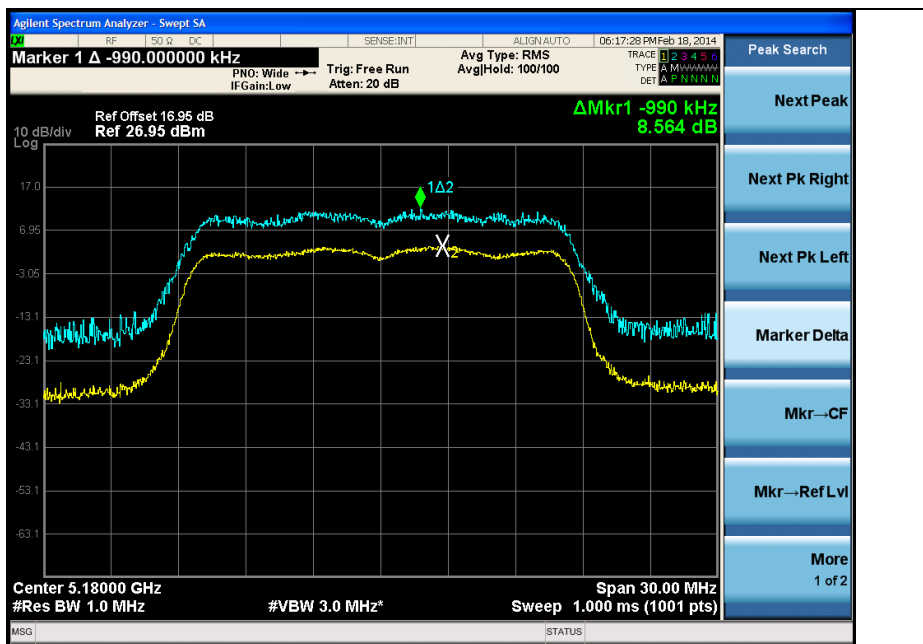

The results shown in this test report refer only to the sample(s) tested unless otherwise stated. This test report cannot be reproduced, except in full, without prior written permission of the Company.

- 11n\_HT20

5 180 MHz(MCS0)

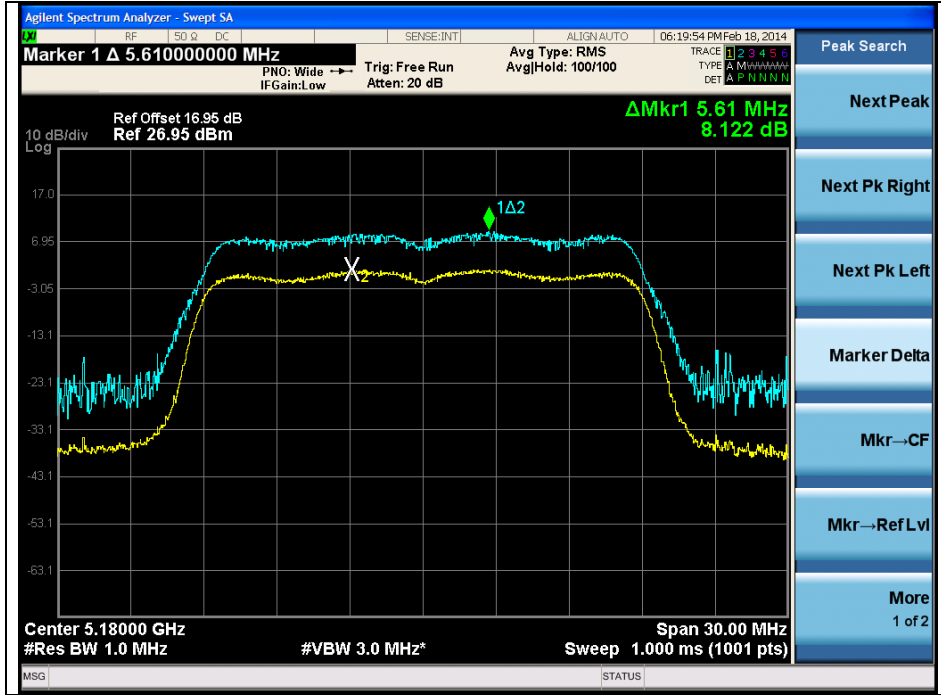

5 180 MHz(MCS1)

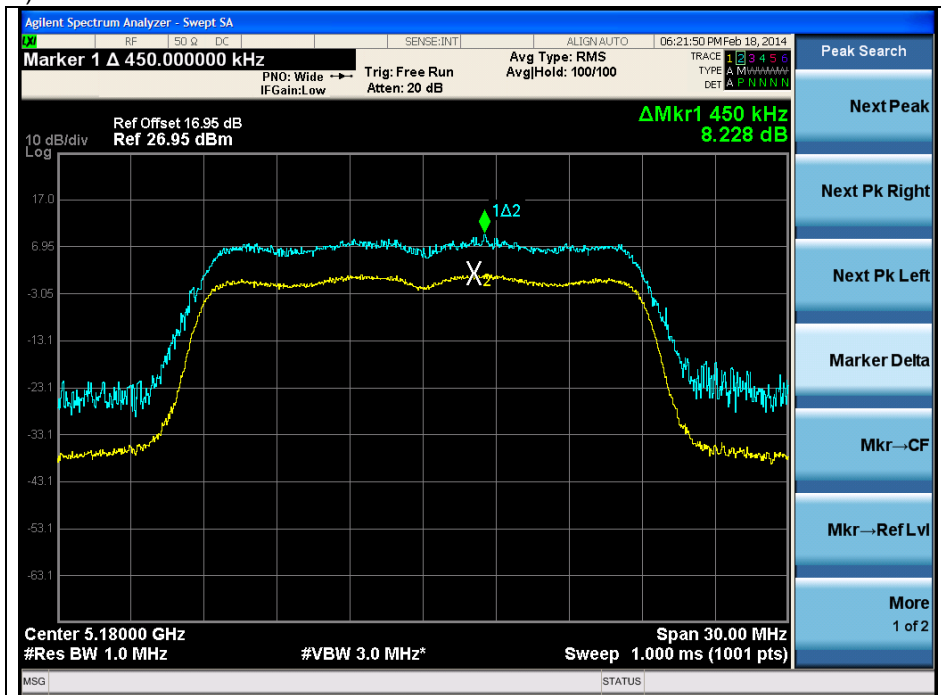

The results shown in this test report refer only to the sample(s) tested unless otherwise stated. This test report cannot be reproduced, except in full, without prior written permission of the Company.

5 180 MHz(MCS2)

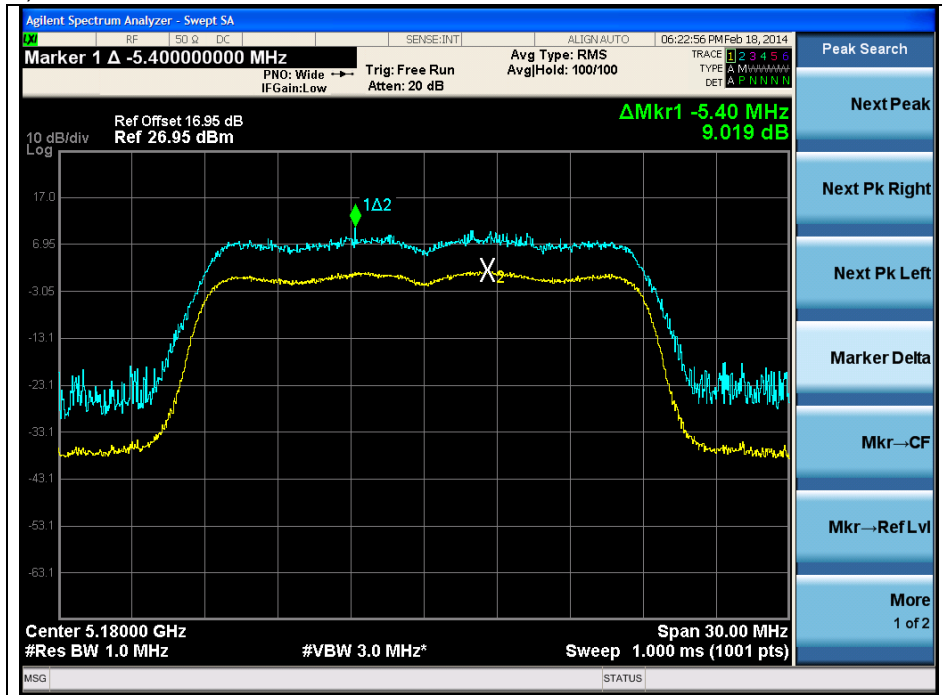

5 180 MHz(MCS3)

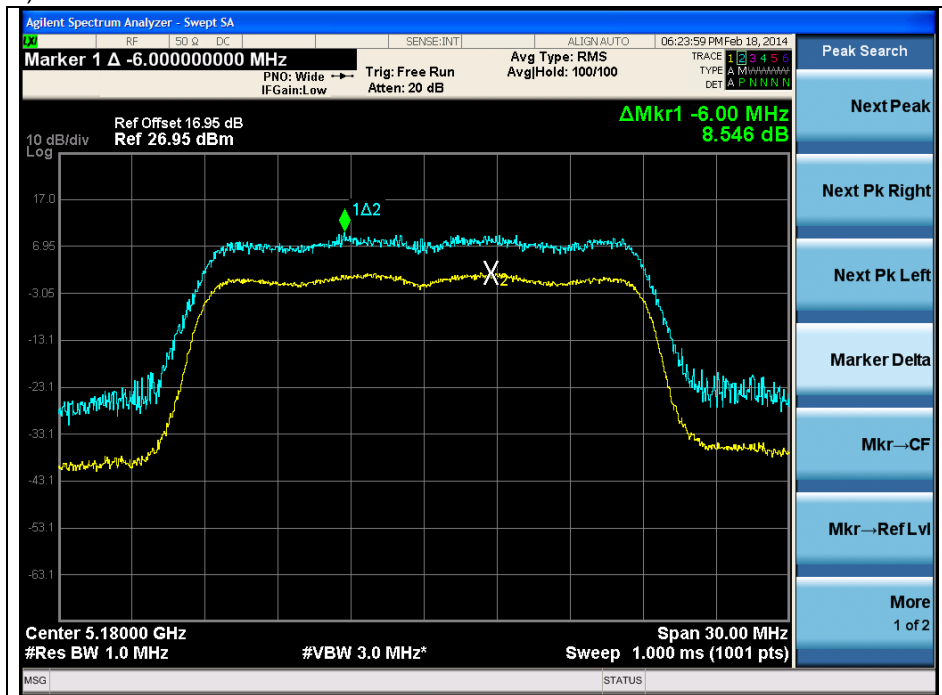

The results shown in this test report refer only to the sample(s) tested unless otherwise stated. This test report cannot be reproduced, except in full, without prior written permission of the Company.

5 180 MHz(MCS4)

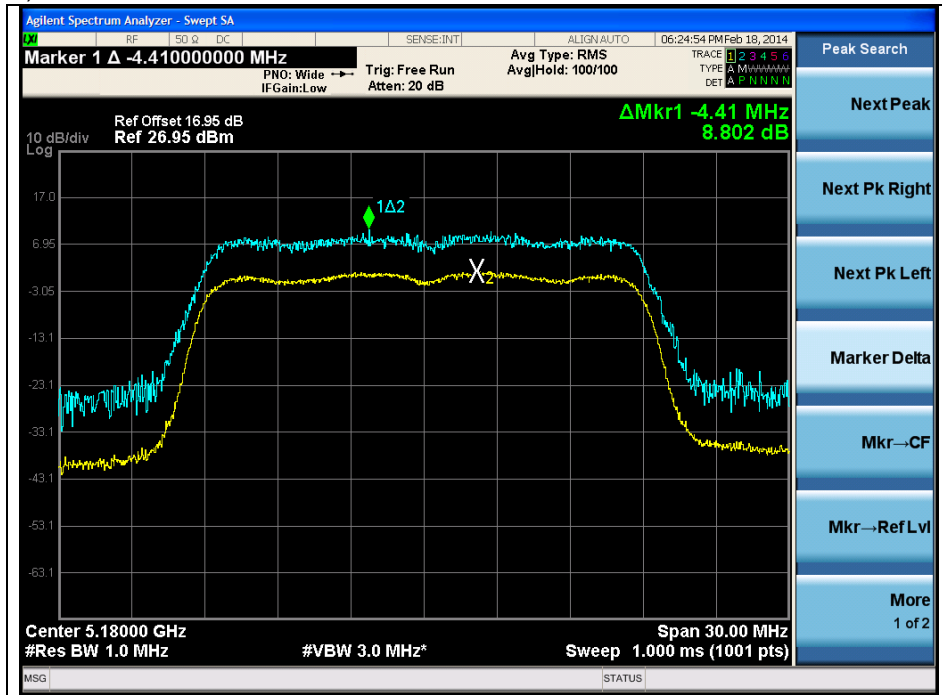

5 180 MHz(MCS5)

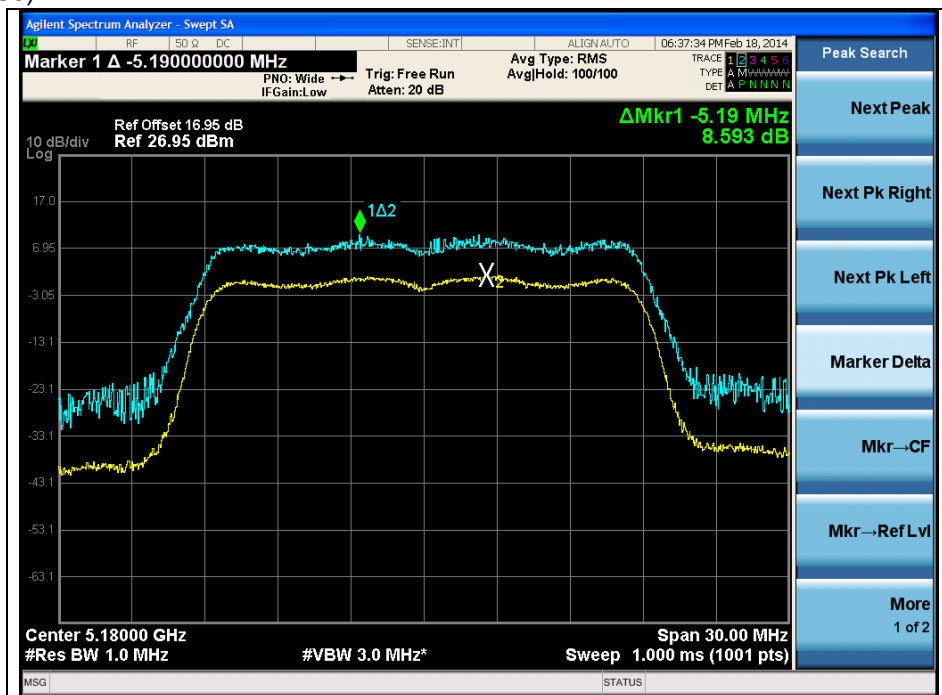

The results shown in this test report refer only to the sample(s) tested unless otherwise stated. This test report cannot be reproduced, except in full, without prior written permission of the Company.

5 180 MHz(MCS6)

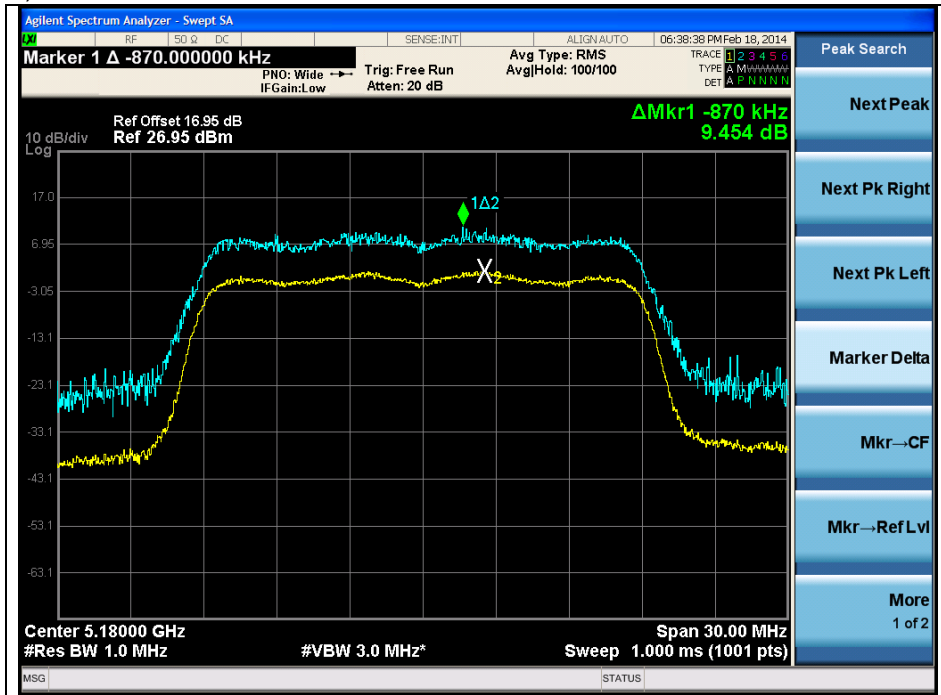

5 180 MHz(MCS7)

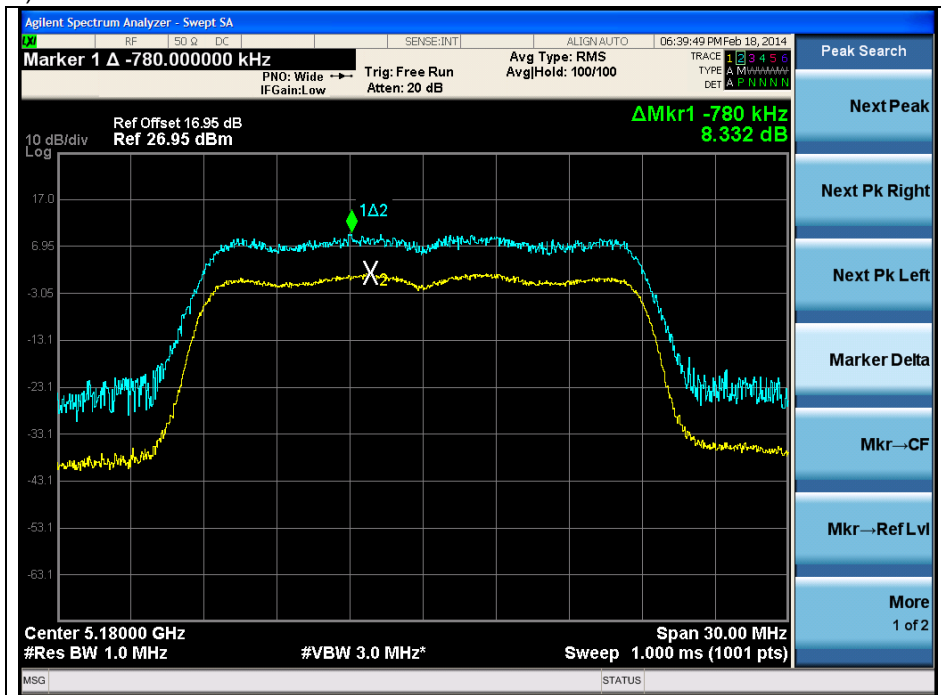

The results shown in this test report refer only to the sample(s) tested unless otherwise stated. This test report cannot be reproduced, except in full, without prior written permission of the Company.

5 180 MHz(MCS8)

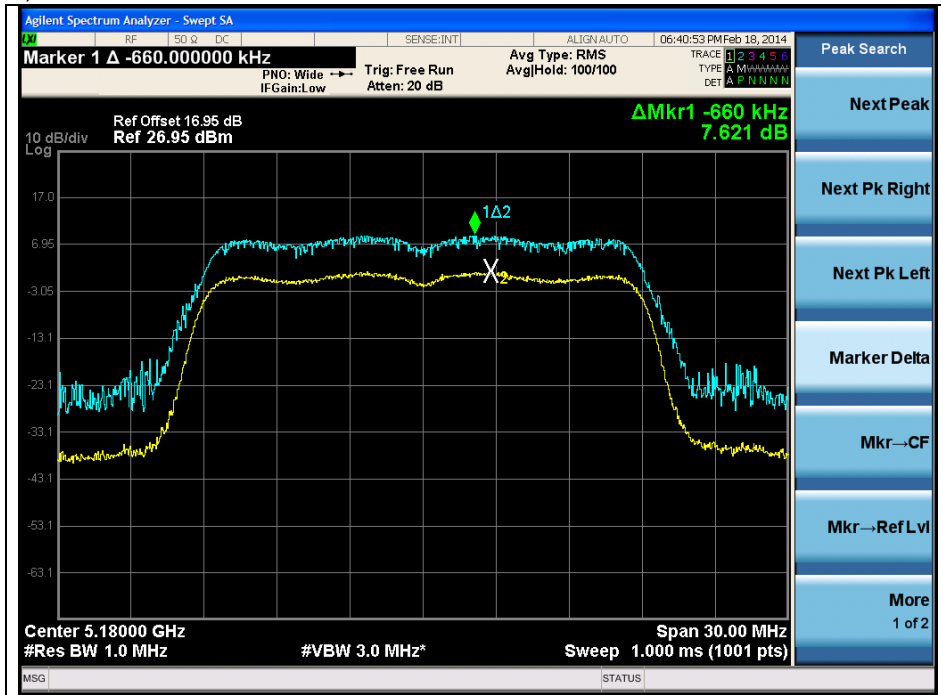

5 180 MHz(MCS9)

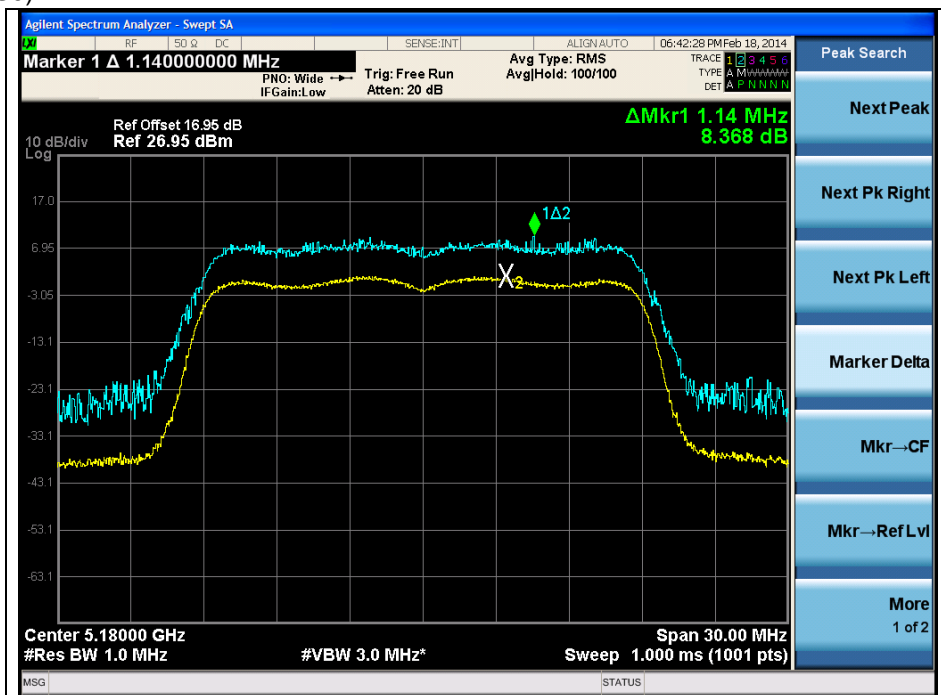

The results shown in this test report refer only to the sample(s) tested unless otherwise stated. This test report cannot be reproduced, except in full, without prior written permission of the Company.

5 180 MHz(MCS10)

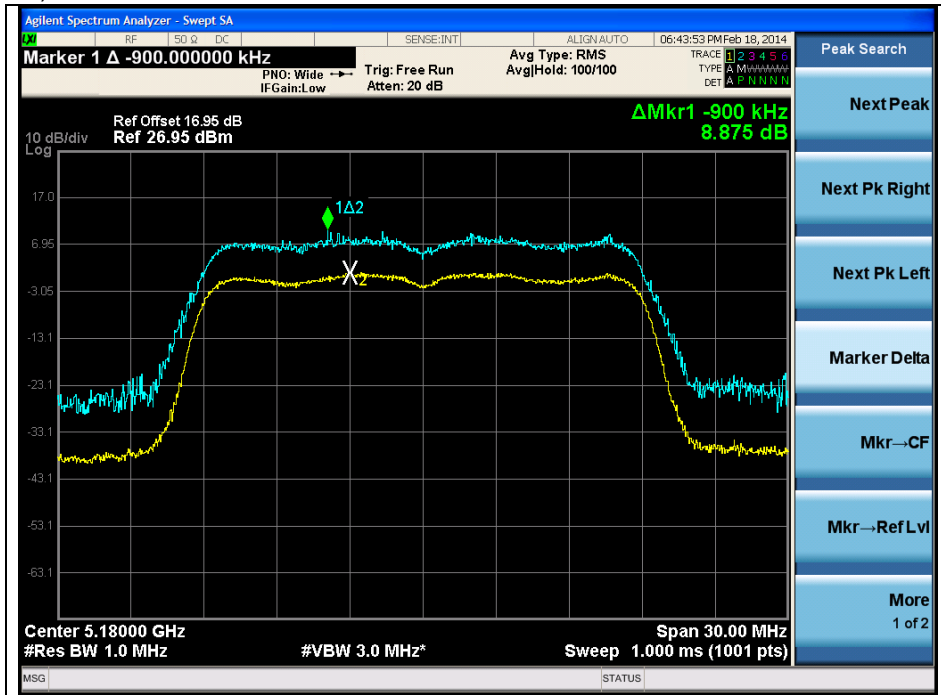

5 180 MHz(MCS11)

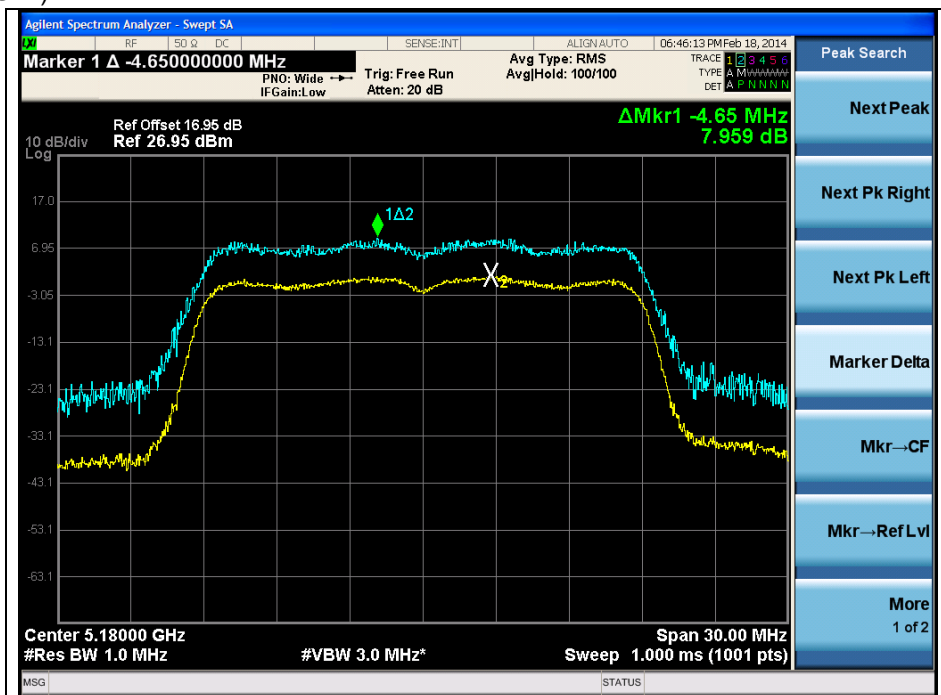

The results shown in this test report refer only to the sample(s) tested unless otherwise stated. This test report cannot be reproduced, except in full, without prior written permission of the Company.

5 180 MHz(MCS12)

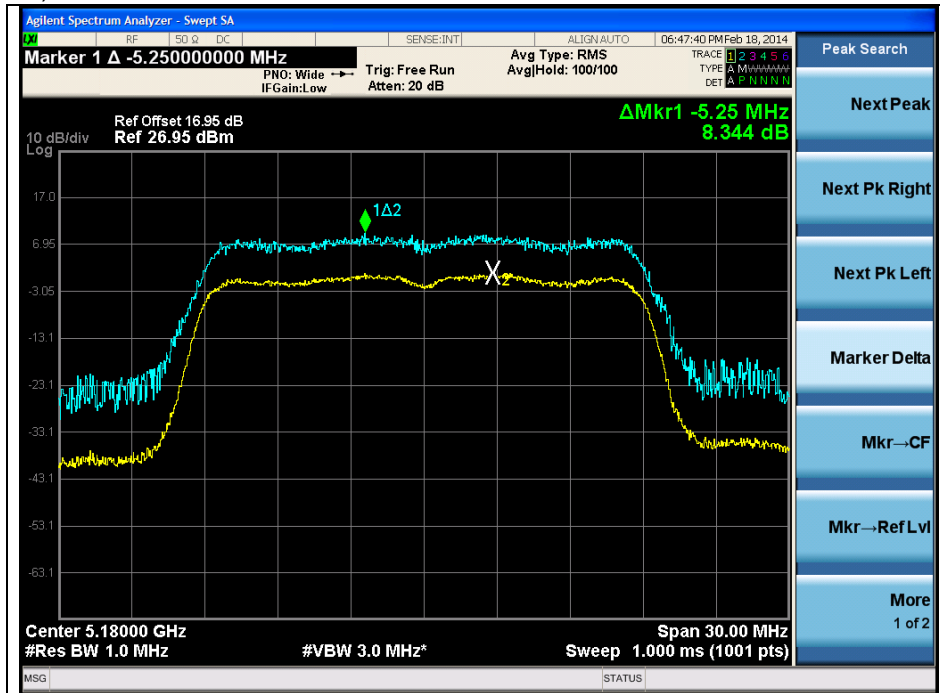

5 180 MHz(MCS13)

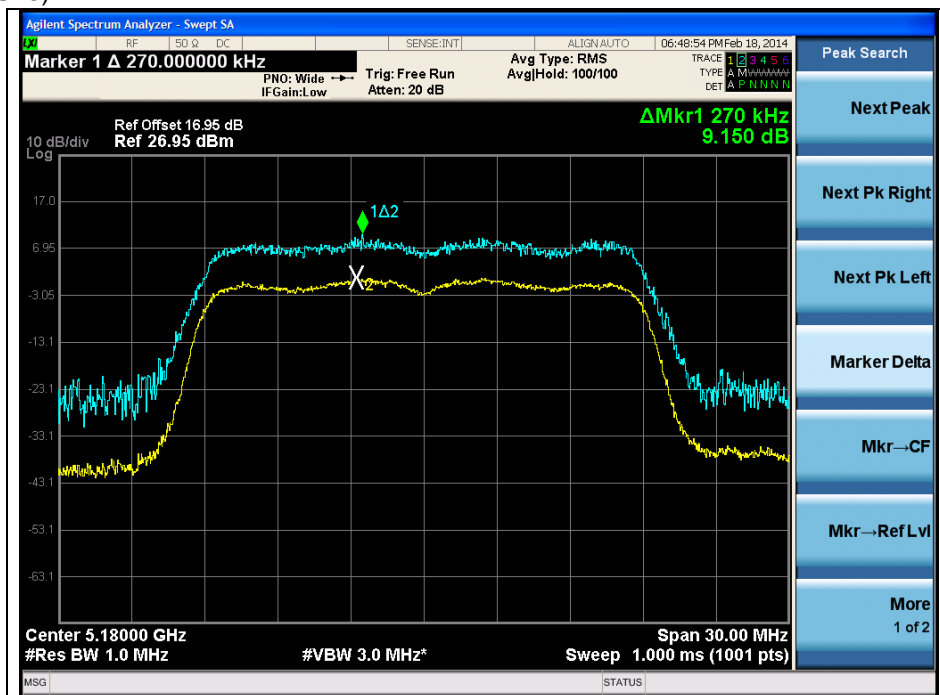

The results shown in this test report refer only to the sample(s) tested unless otherwise stated. This test report cannot be reproduced, except in full, without prior written permission of the Company.

5 180 MHz(MCS14)

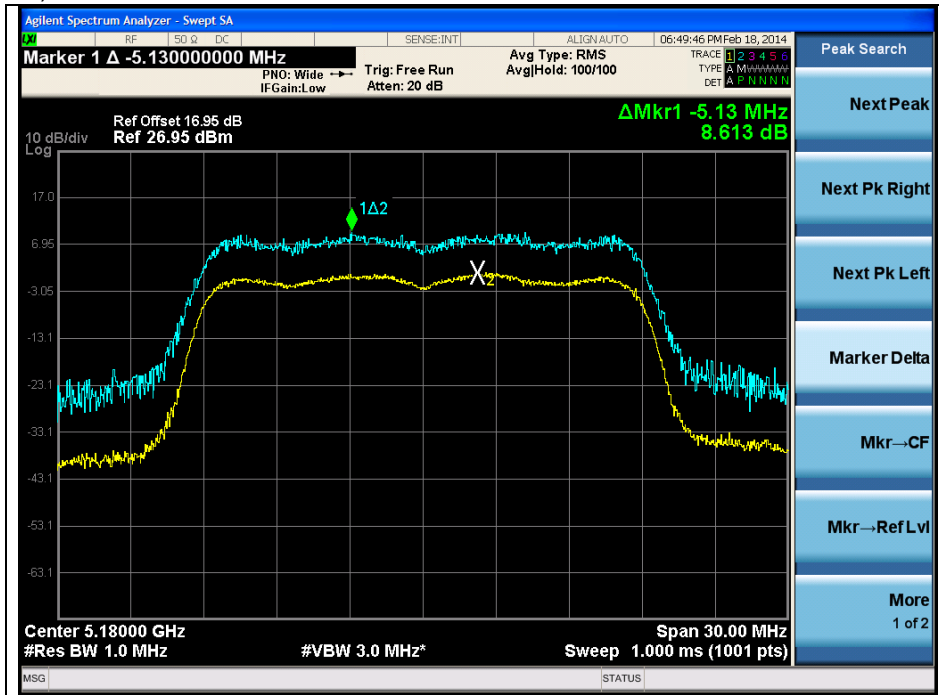

5 180 MHz(MCS15)

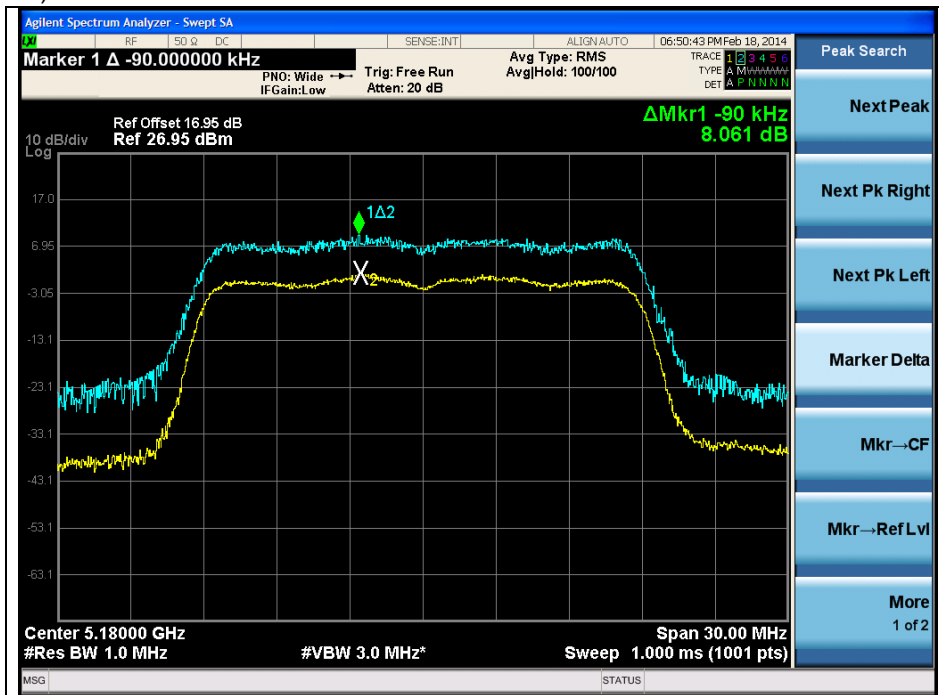

The results shown in this test report refer only to the sample(s) tested unless otherwise stated. This test report cannot be reproduced, except in full, without prior written permission of the Company.

- 11n\_HT40

5 190 MHz(MCS0)



5 190 MHz(MCS1)

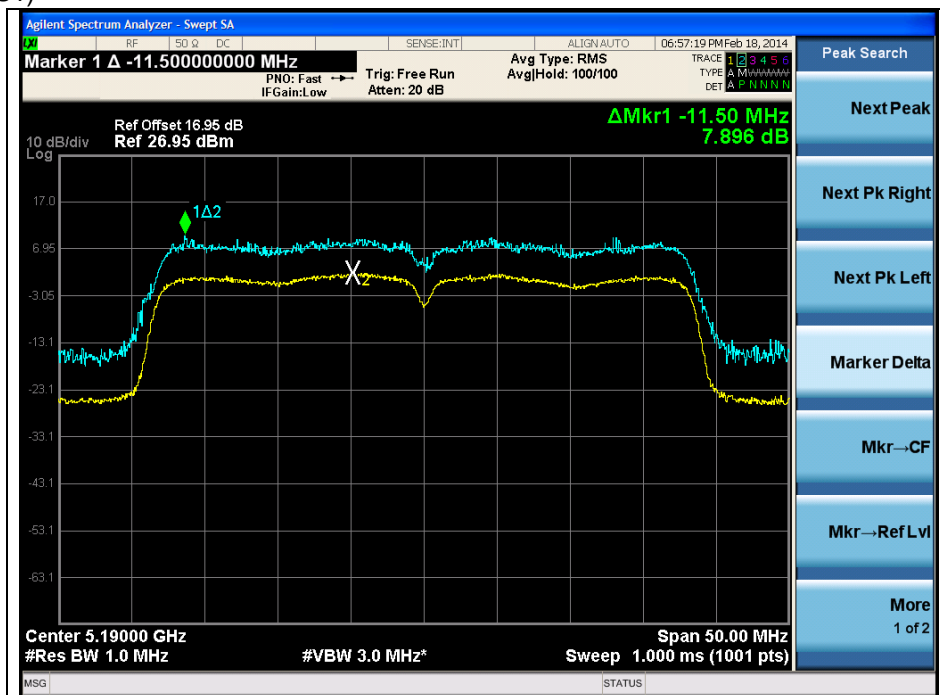

The results shown in this test report refer only to the sample(s) tested unless otherwise stated. This test report cannot be reproduced, except in full, without prior written permission of the Company.

5 190 MHz(MCS2)

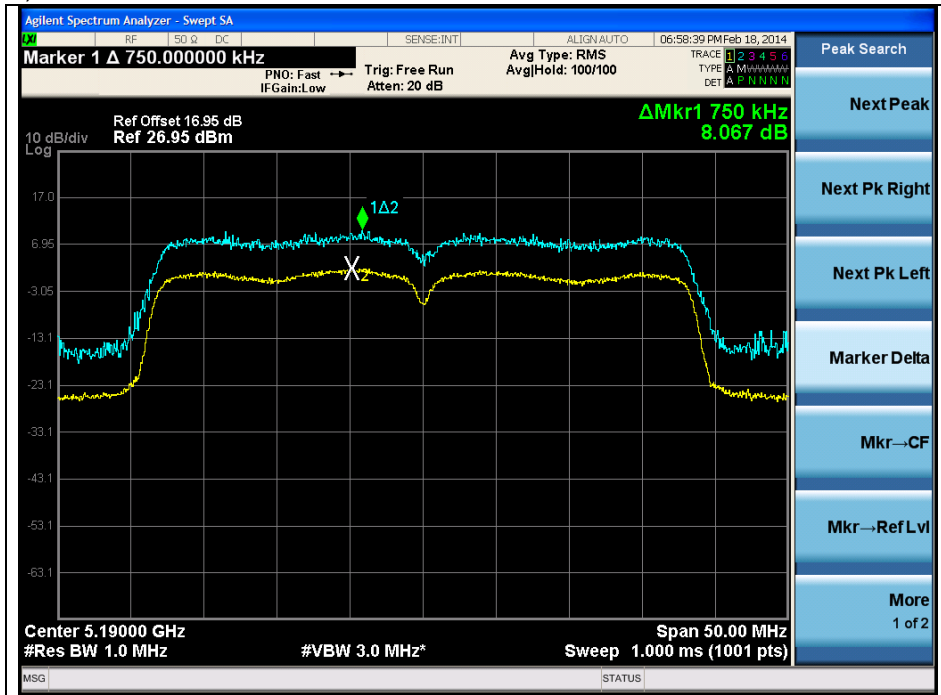

5 190 MHz(MCS3)

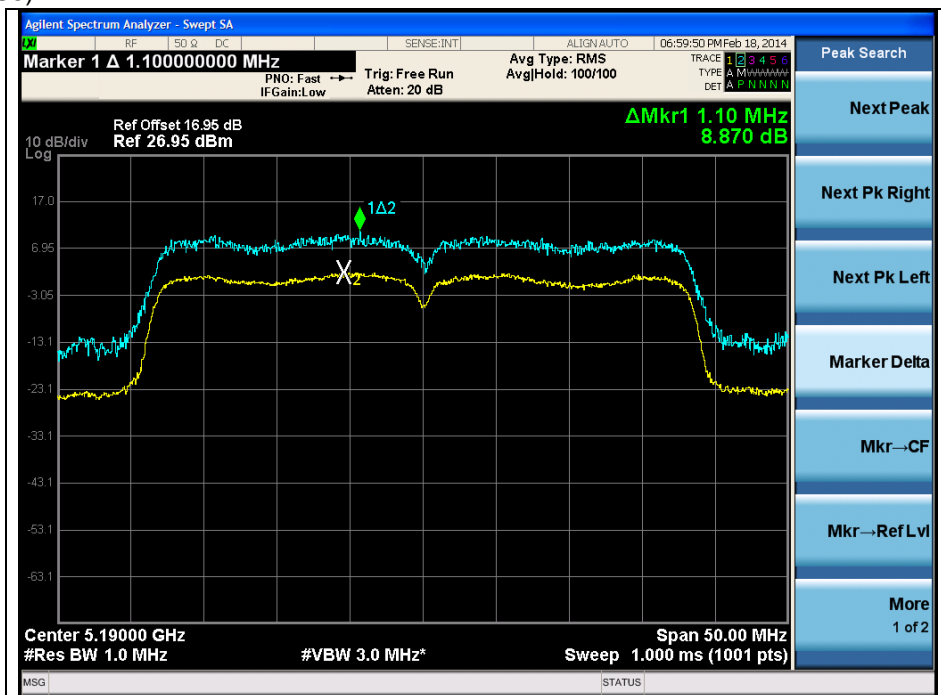

The results shown in this test report refer only to the sample(s) tested unless otherwise stated. This test report cannot be reproduced, except in full, without prior written permission of the Company.

5 190 MHz(MCS4)

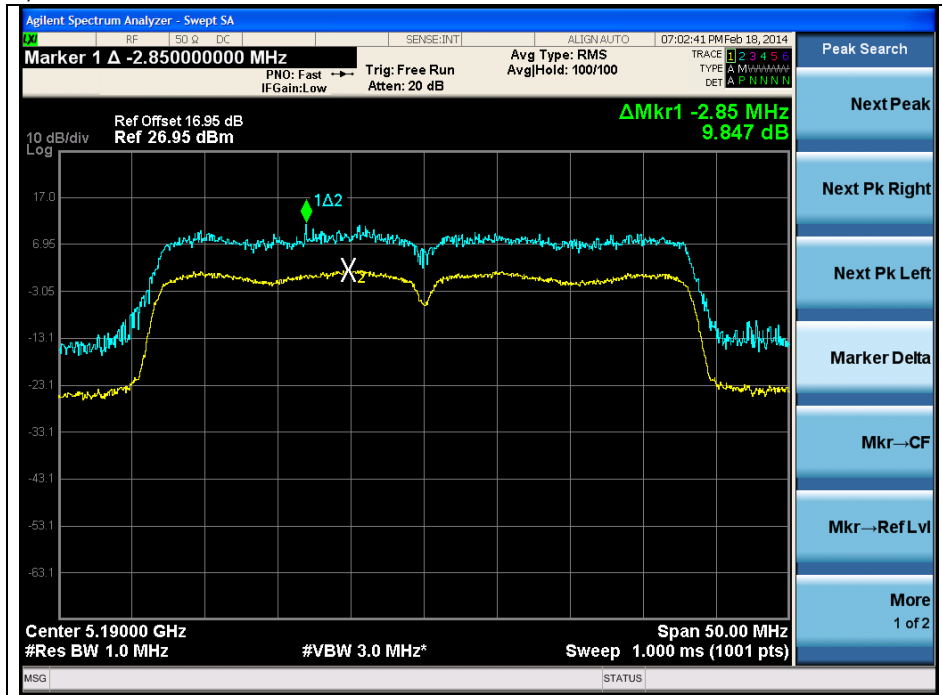

5 190 MHz(MCS5)

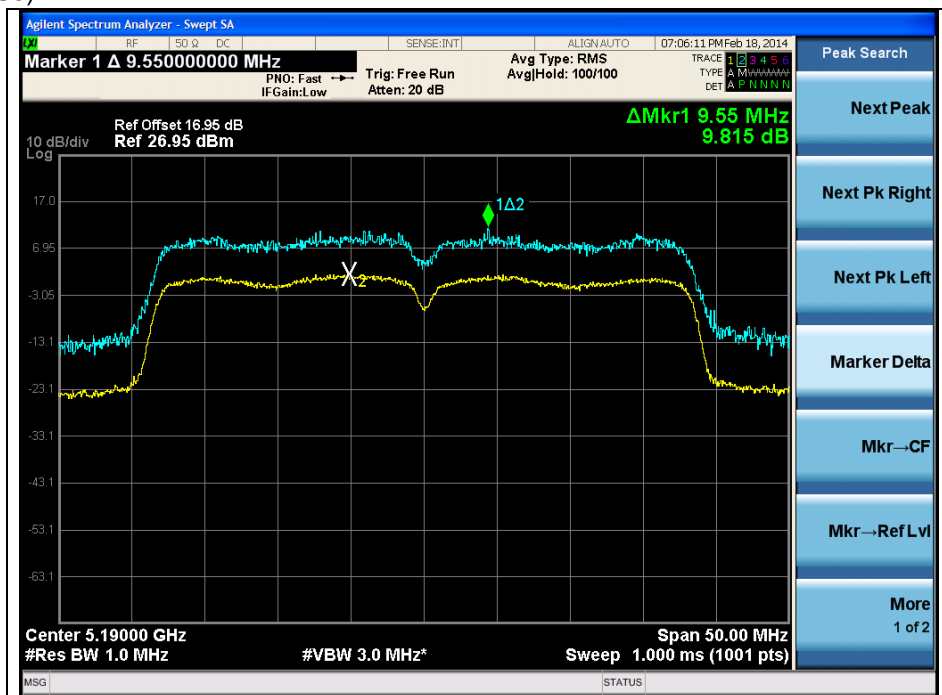

The results shown in this test report refer only to the sample(s) tested unless otherwise stated. This test report cannot be reproduced, except in full, without prior written permission of the Company.

5 190 MHz(MCS6)

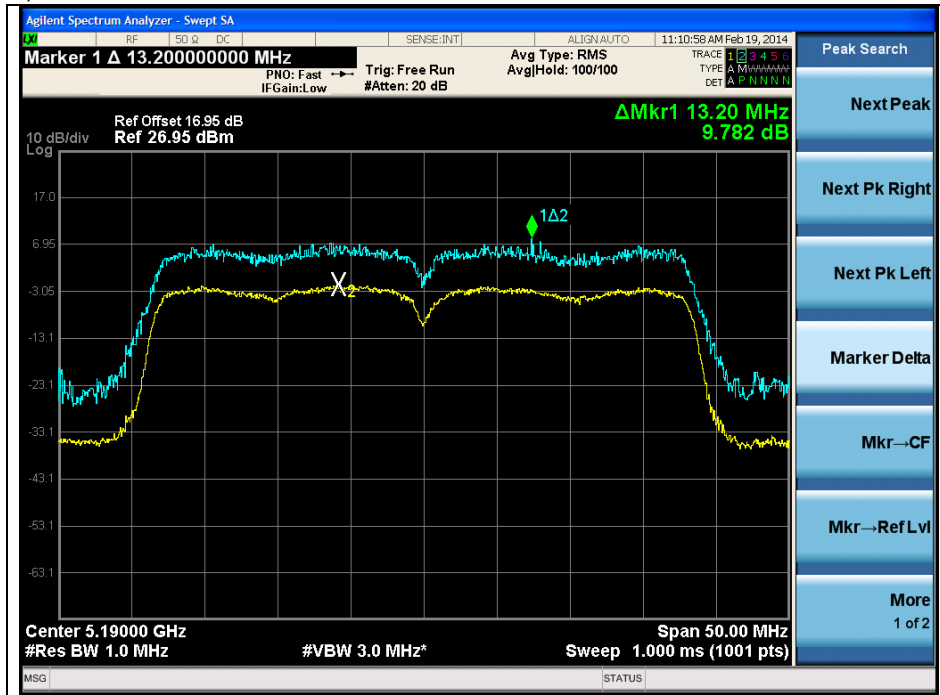

5 190 MHz(MCS7)

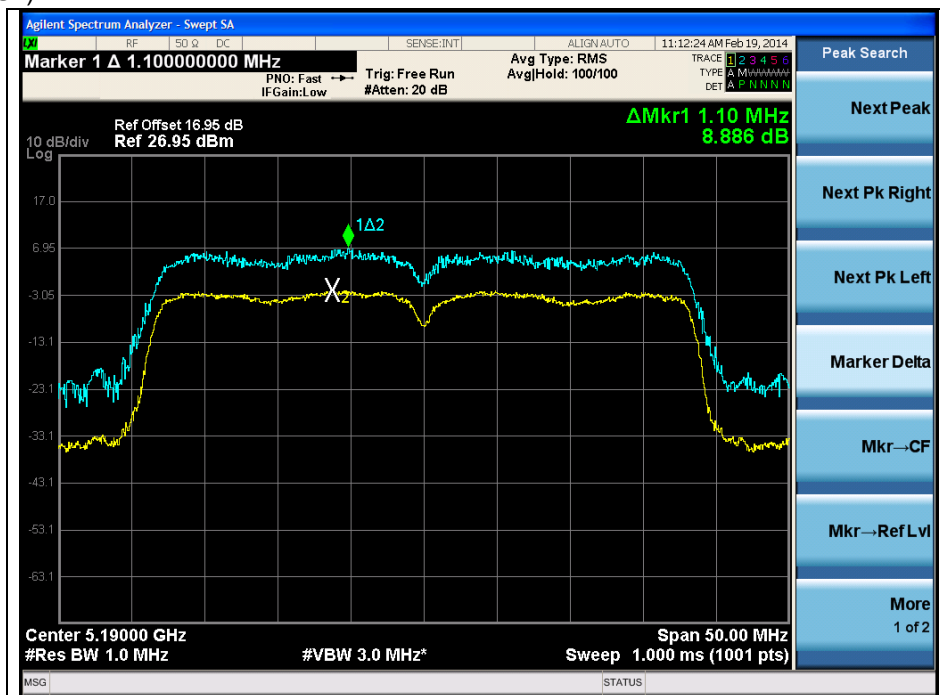

The results shown in this test report refer only to the sample(s) tested unless otherwise stated. This test report cannot be reproduced, except in full, without prior written permission of the Company.

5 190 MHz(MCS8)

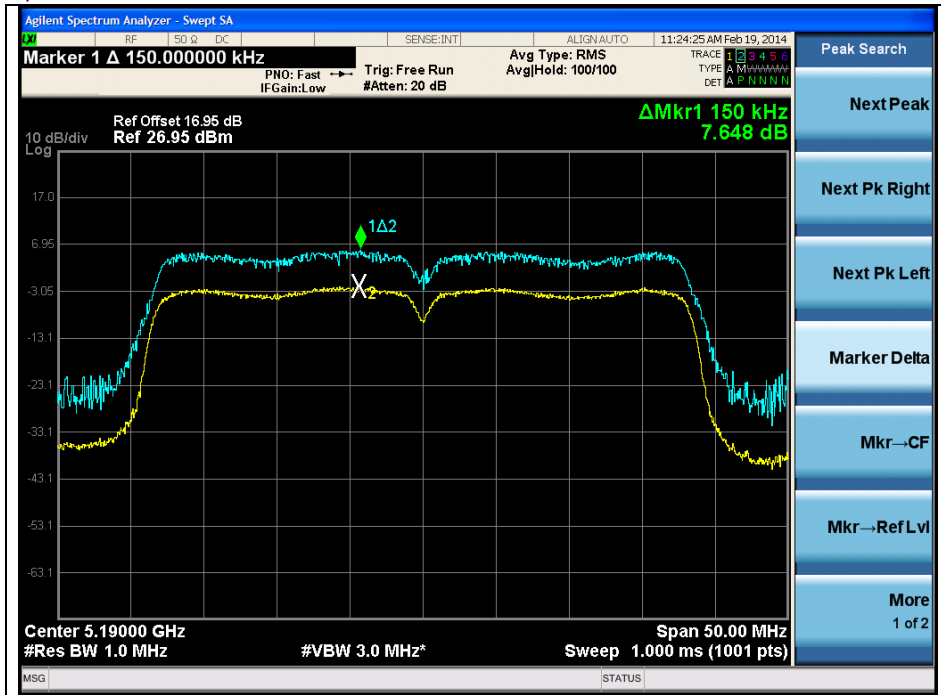

5 190 MHz(MCS9)

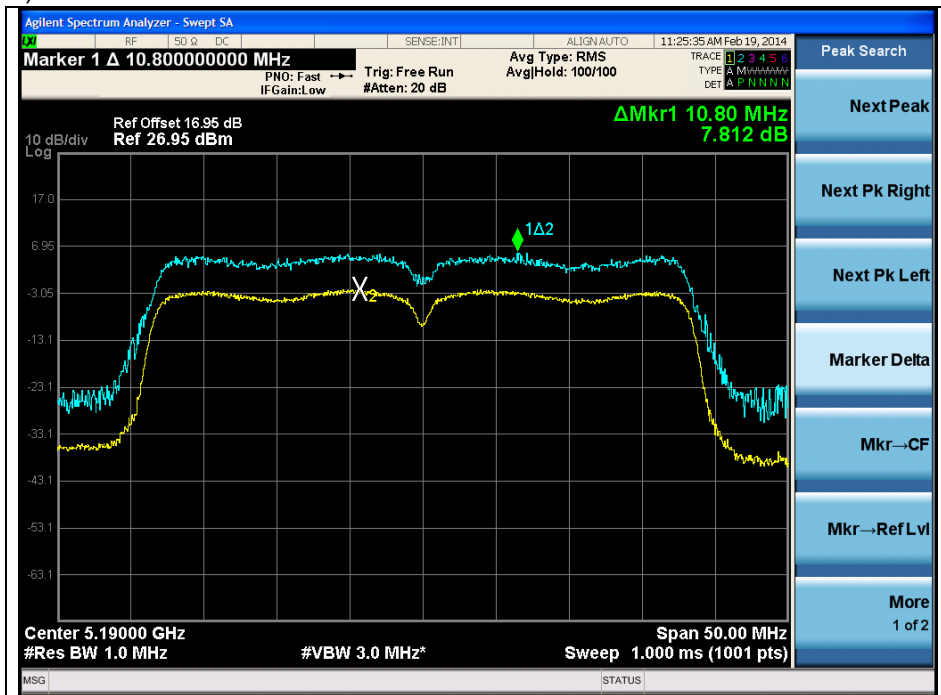

The results shown in this test report refer only to the sample(s) tested unless otherwise stated. This test report cannot be reproduced, except in full, without prior written permission of the Company.

5 190 MHz(MCS10)

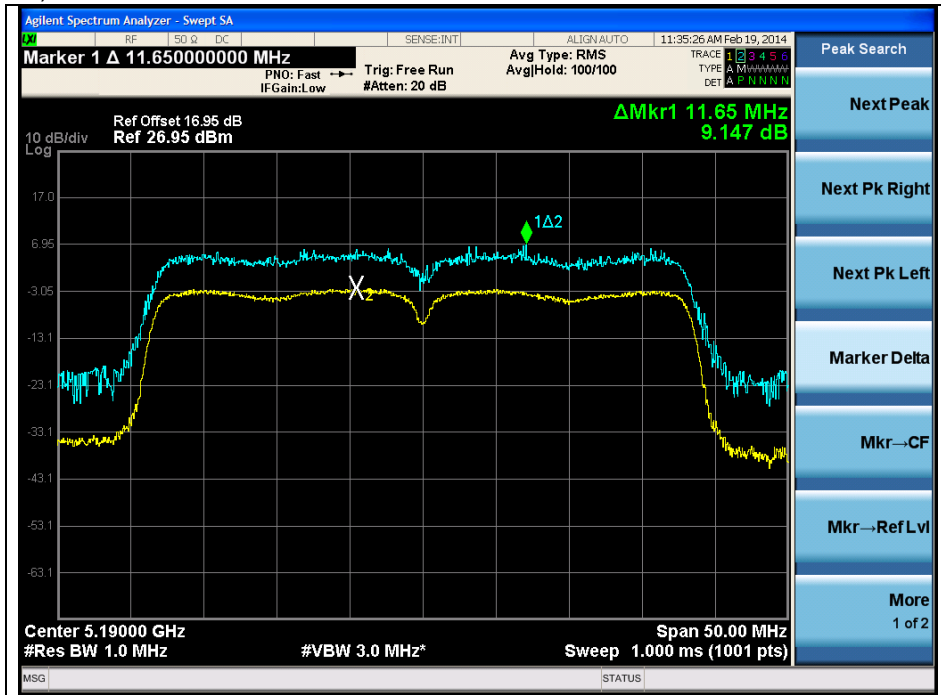

5 190 MHz(MCS11)

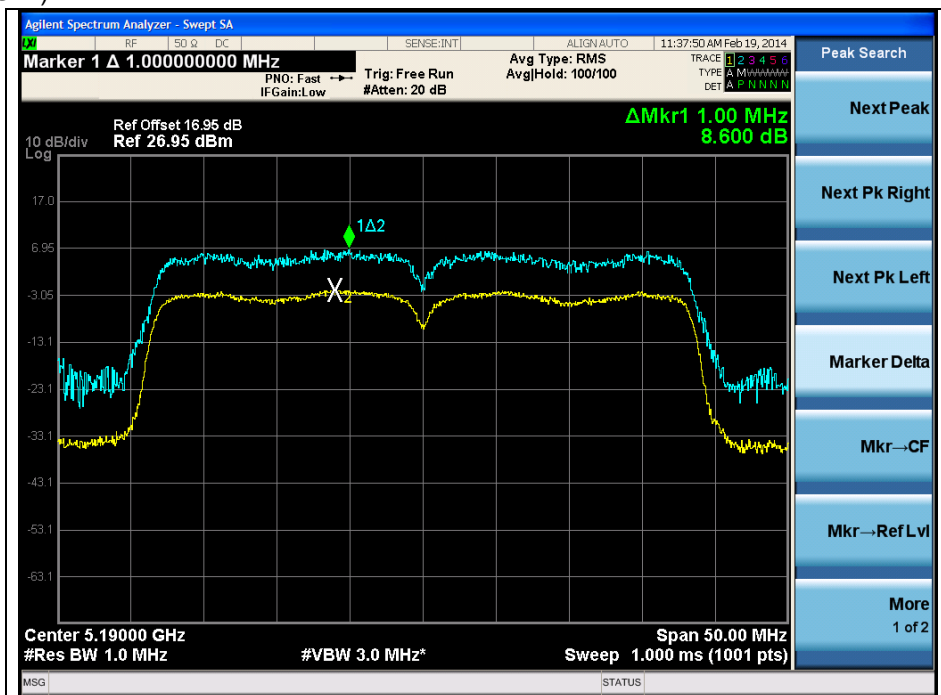

The results shown in this test report refer only to the sample(s) tested unless otherwise stated. This test report cannot be reproduced, except in full, without prior written permission of the Company.

5 190 MHz(MCS12)

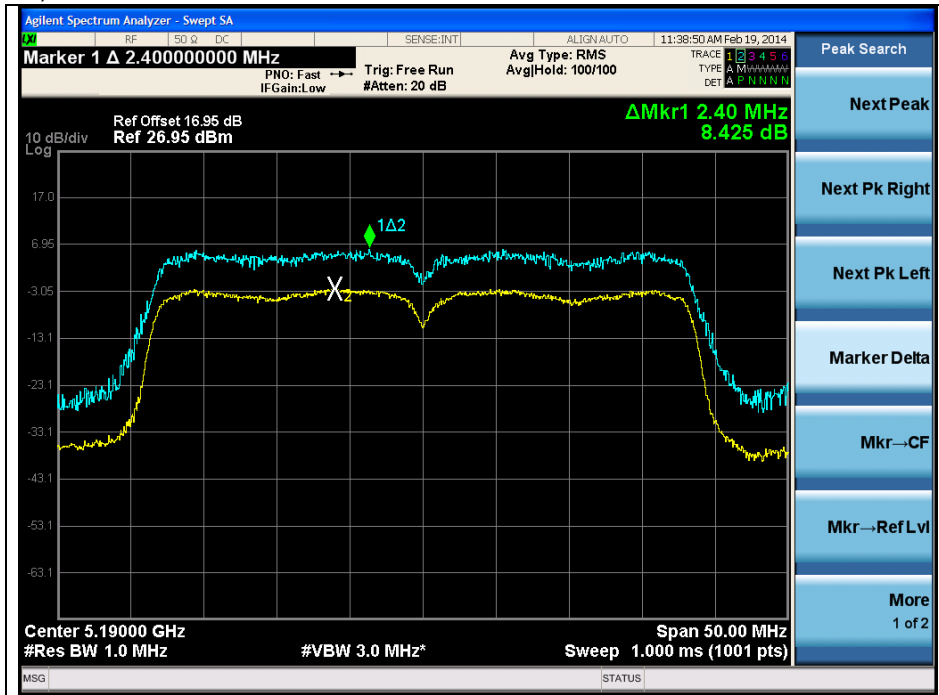

5 190 MHz(MCS13)

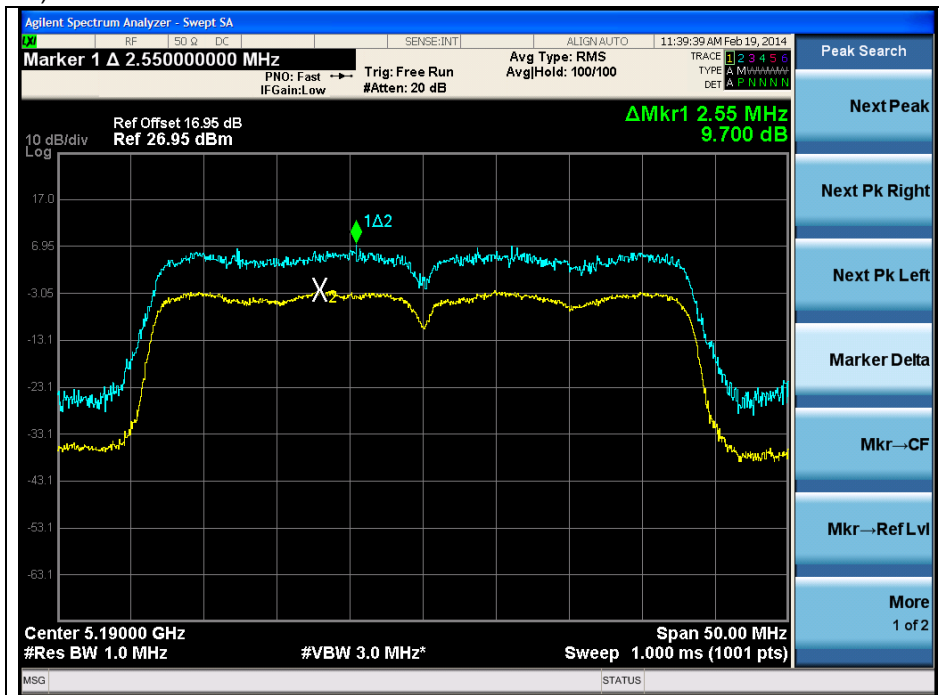

The results shown in this test report refer only to the sample(s) tested unless otherwise stated. This test report cannot be reproduced, except in full, without prior written permission of the Company.

5 190 MHz(MCS14)

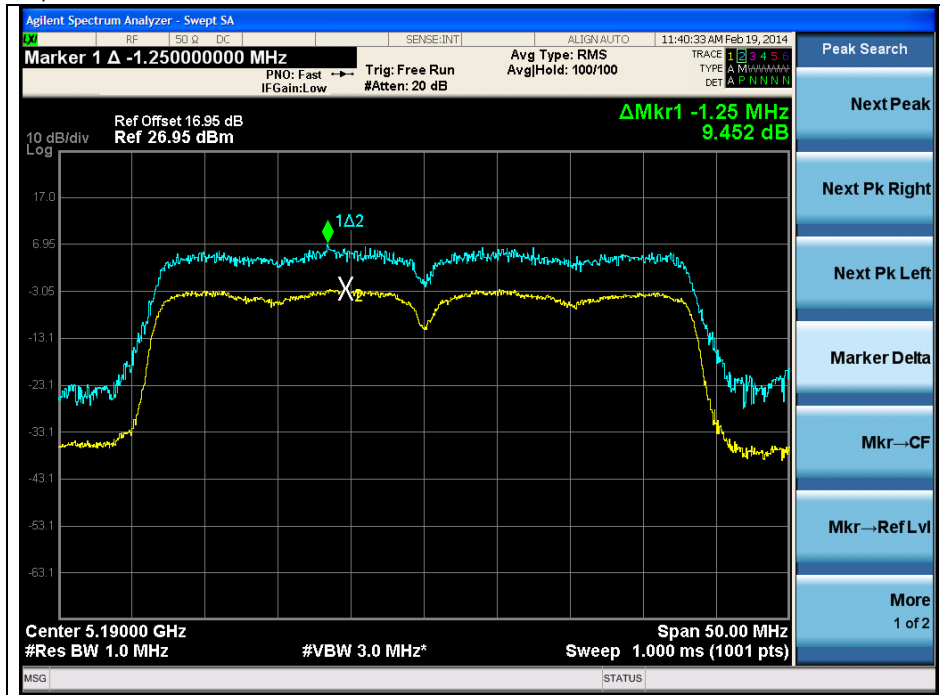

5 190 MHz(MCS15)

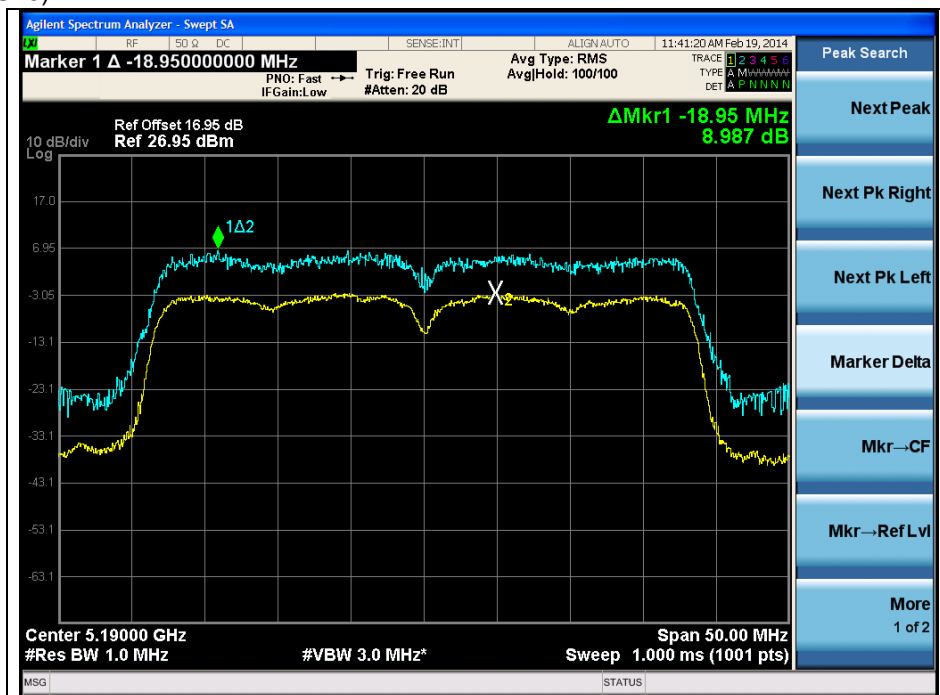

The results shown in this test report refer only to the sample(s) tested unless otherwise stated. This test report cannot be reproduced, except in full, without prior written permission of the Company.

- 11ac\_VHT20

5 180 MHz(MCS0)

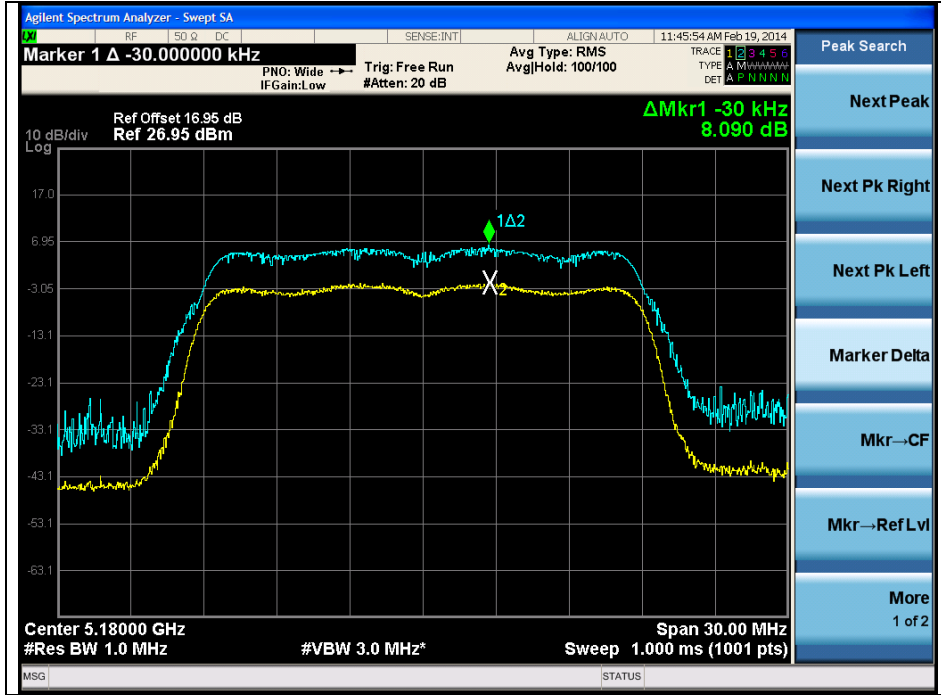

5 180 MHz(MCS1)

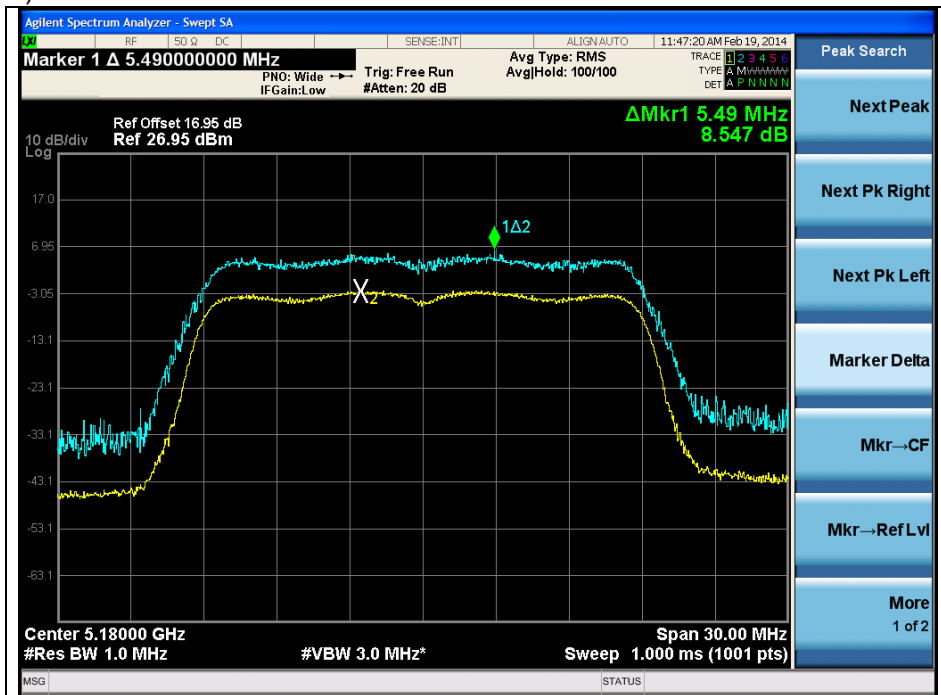

The results shown in this test report refer only to the sample(s) tested unless otherwise stated. This test report cannot be reproduced, except in full, without prior written permission of the Company.

5 180 MHz(MCS2)

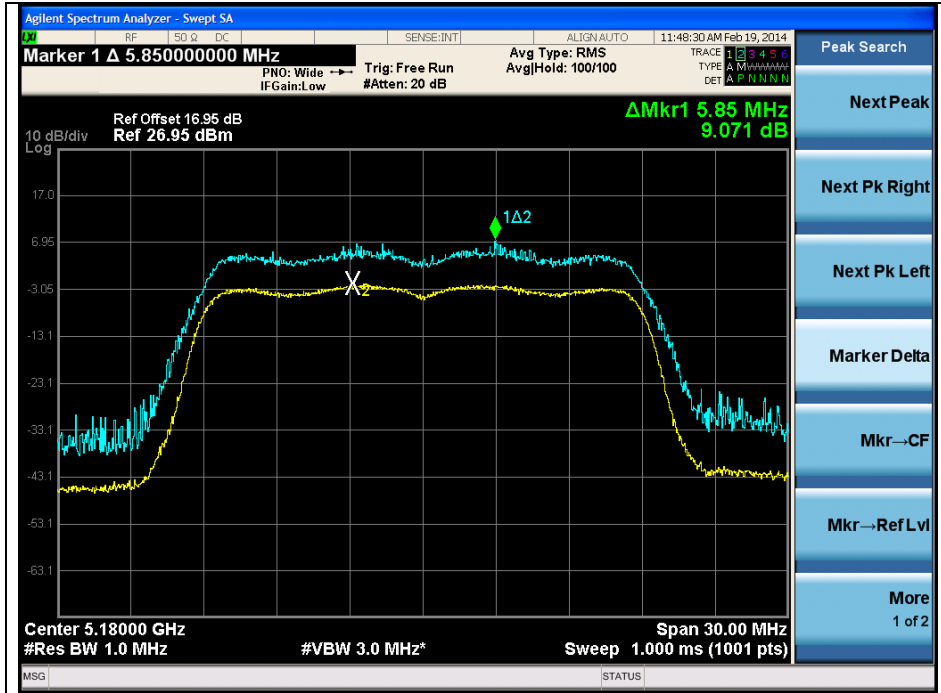

5 180 MHz(MCS3)

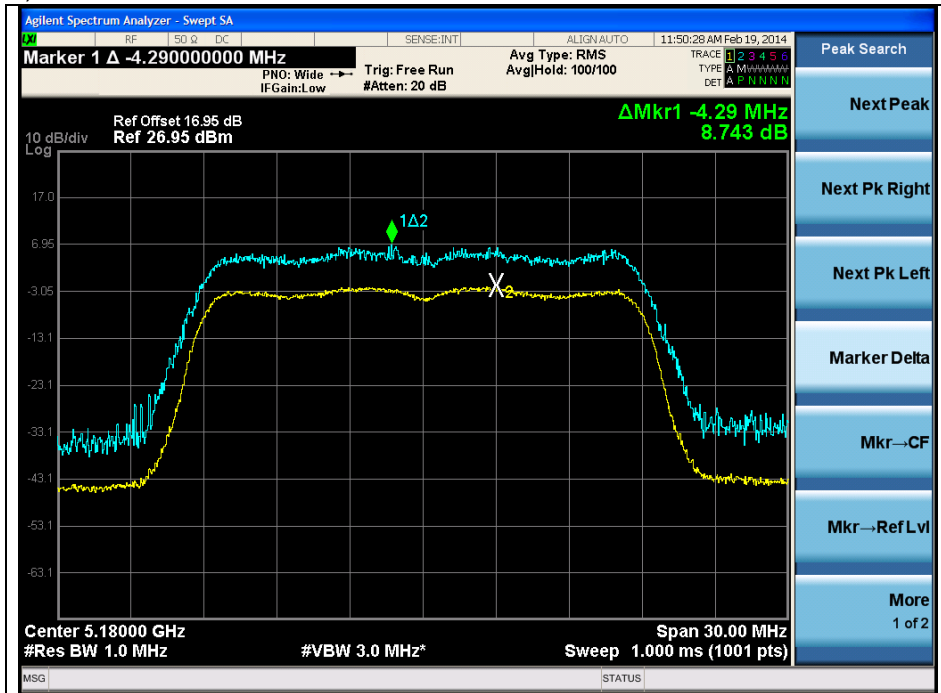

The results shown in this test report refer only to the sample(s) tested unless otherwise stated. This test report cannot be reproduced, except in full, without prior written permission of the Company.

5 180 MHz(MCS4)

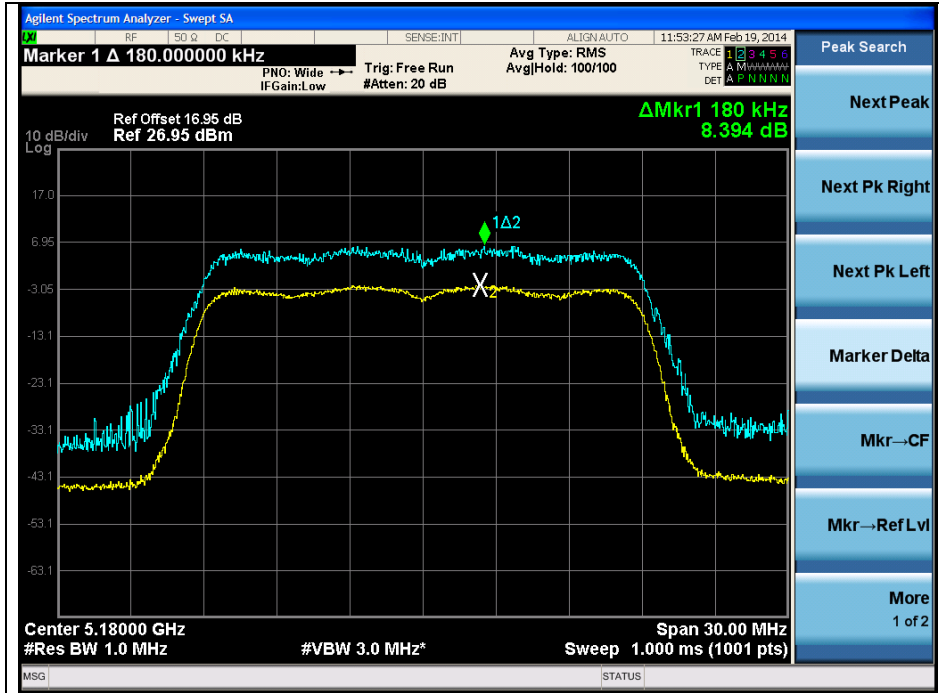

5 180 MHz(MCS5)

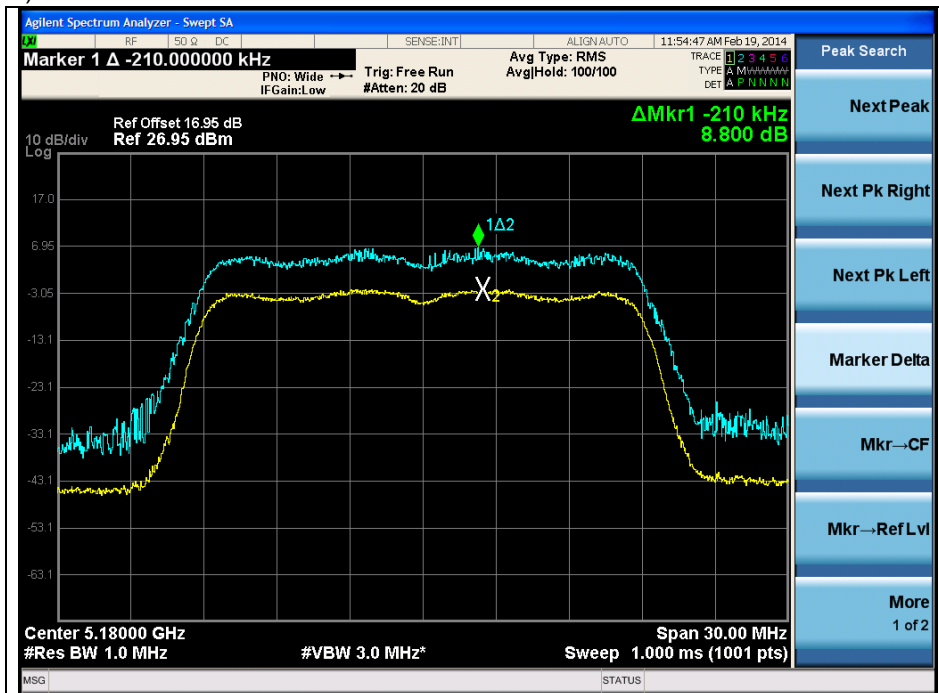

The results shown in this test report refer only to the sample(s) tested unless otherwise stated. This test report cannot be reproduced, except in full, without prior written permission of the Company.

5 180 MHz(MCS6)

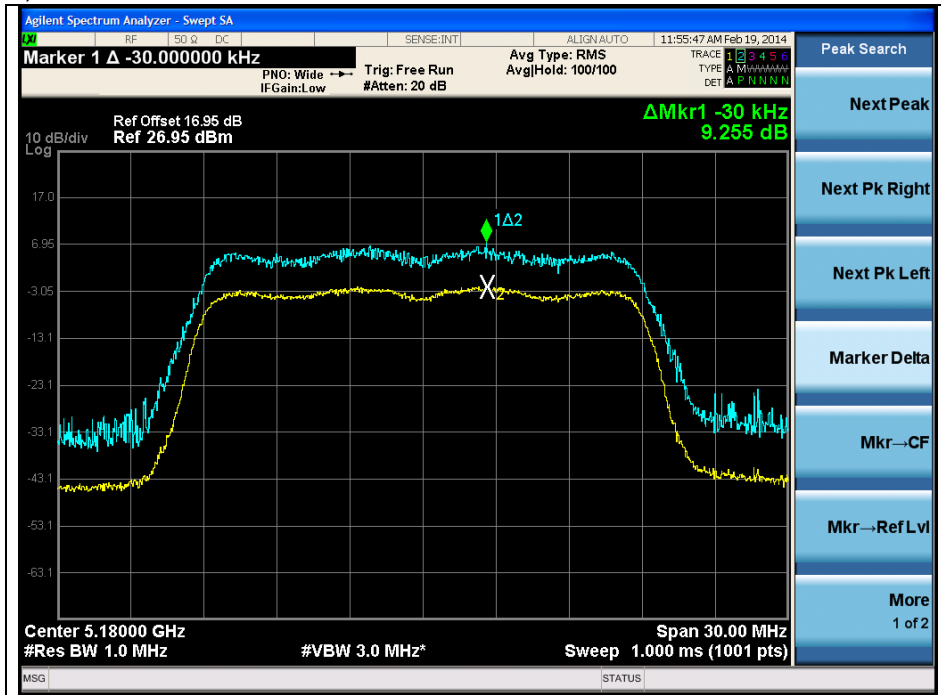

5 180 MHz(MCS7)

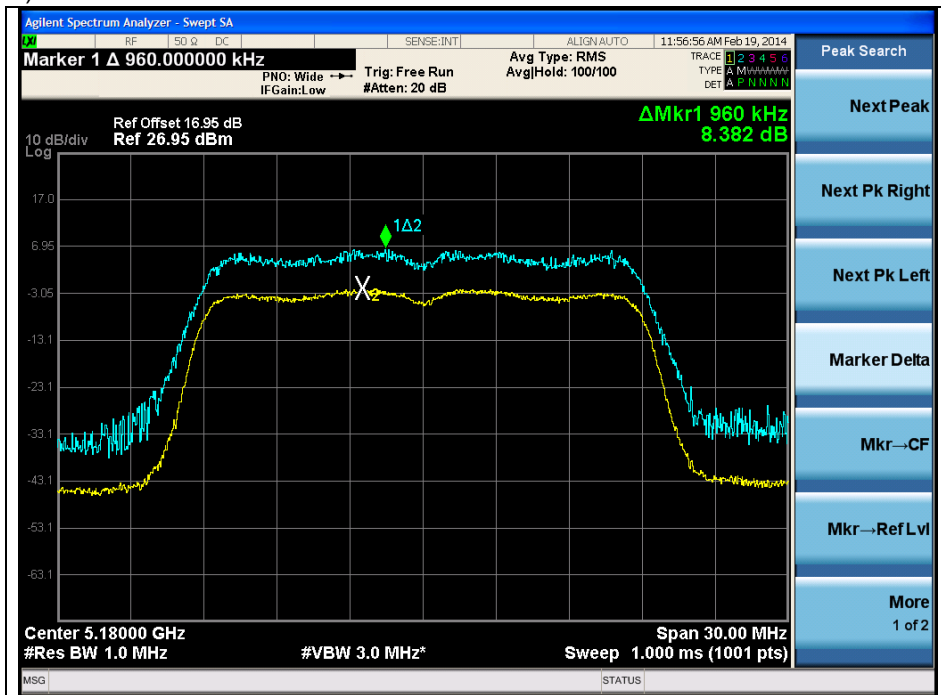

The results shown in this test report refer only to the sample(s) tested unless otherwise stated. This test report cannot be reproduced, except in full, without prior written permission of the Company.

5 180 MHz(MCS8)

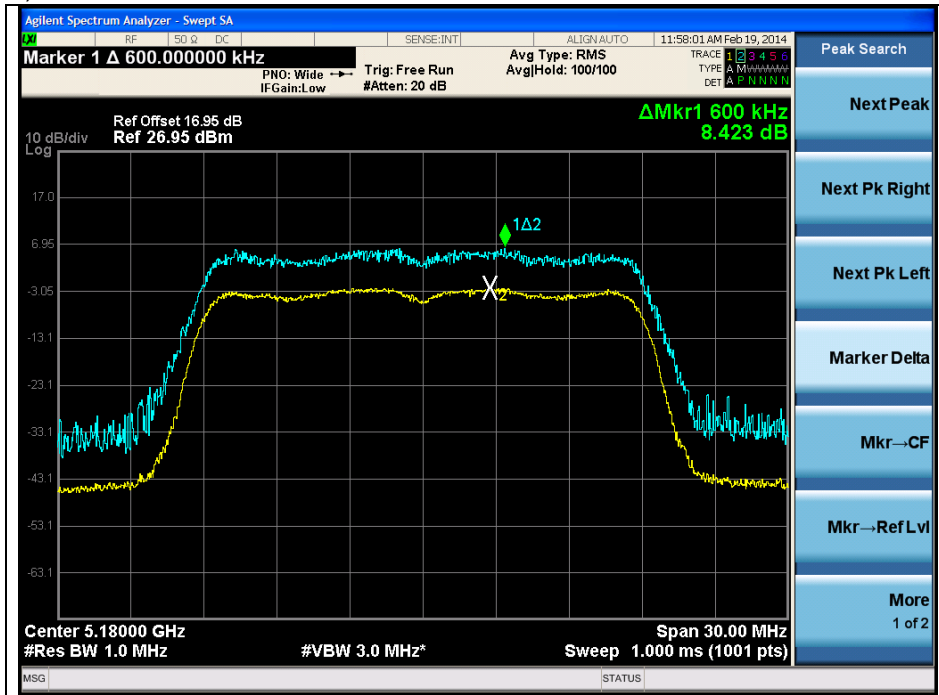

5 180 MHz(MCS9)

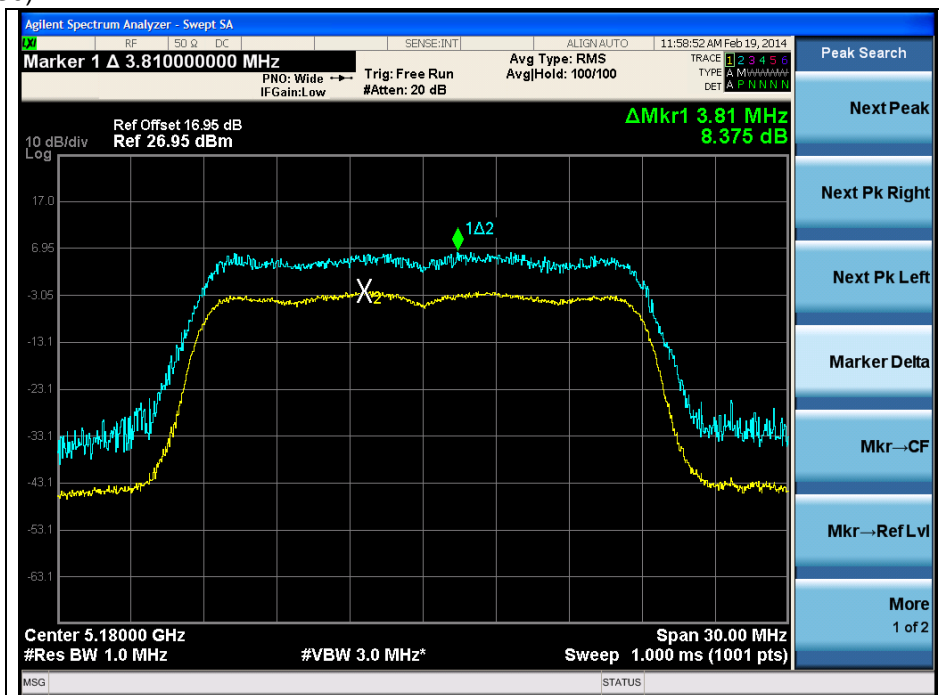

The results shown in this test report refer only to the sample(s) tested unless otherwise stated. This test report cannot be reproduced, except in full, without prior written permission of the Company.

- 11ac\_VHT40

5 190 MHz(MCS0)

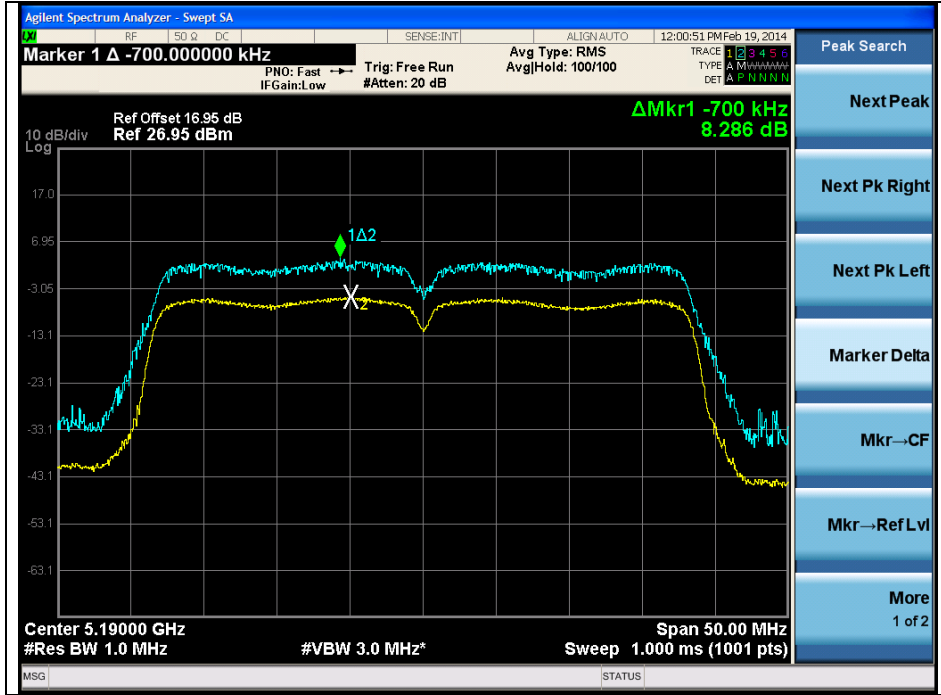

5 190 MHz(MCS1)



The results shown in this test report refer only to the sample(s) tested unless otherwise stated. This test report cannot be reproduced, except in full, without prior written permission of the Company.

5 190 MHz(MCS2)

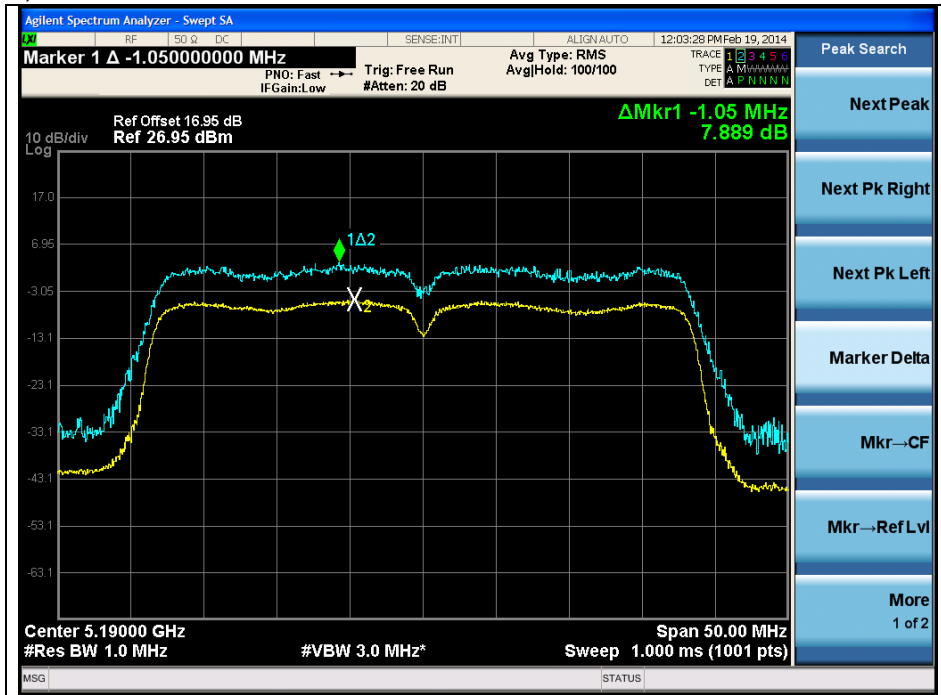

5 190 MHz(MCS3)

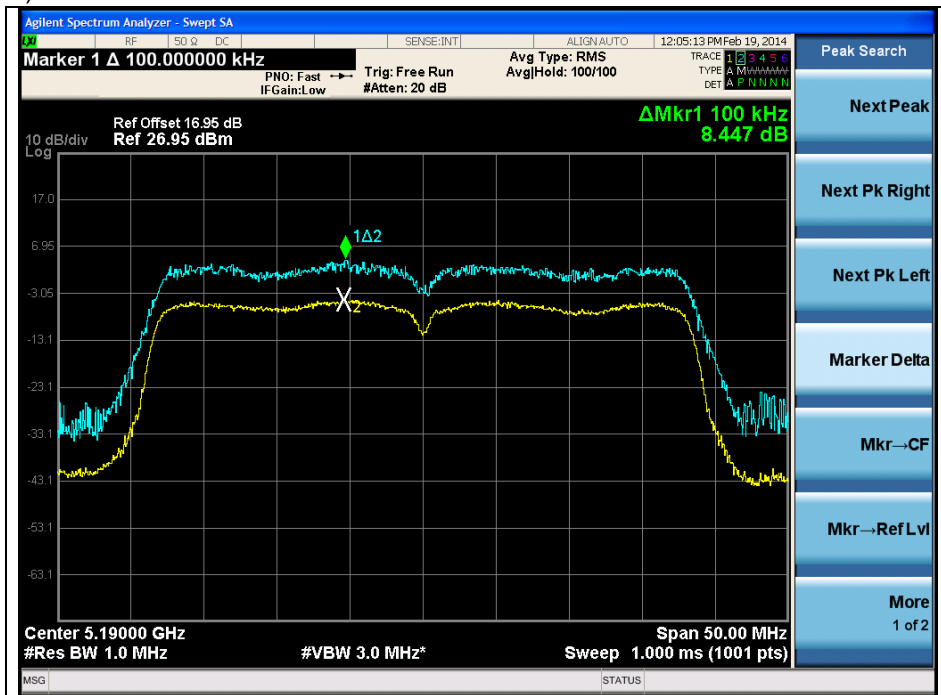

The results shown in this test report refer only to the sample(s) tested unless otherwise stated. This test report cannot be reproduced, except in full, without prior written permission of the Company.

5 190 MHz(MCS4)

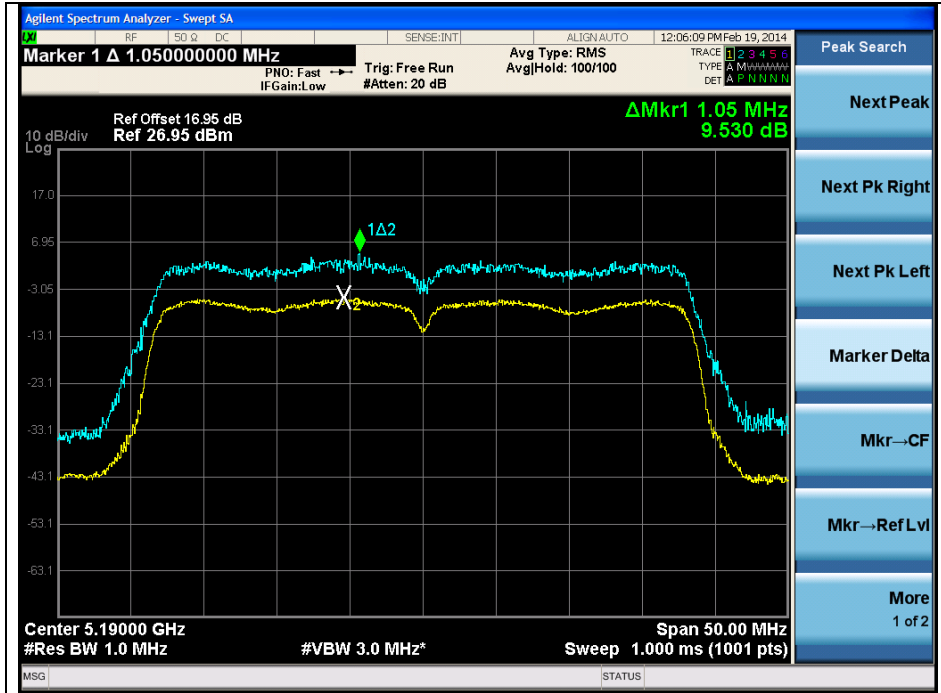

5 190 MHz(MCS5)

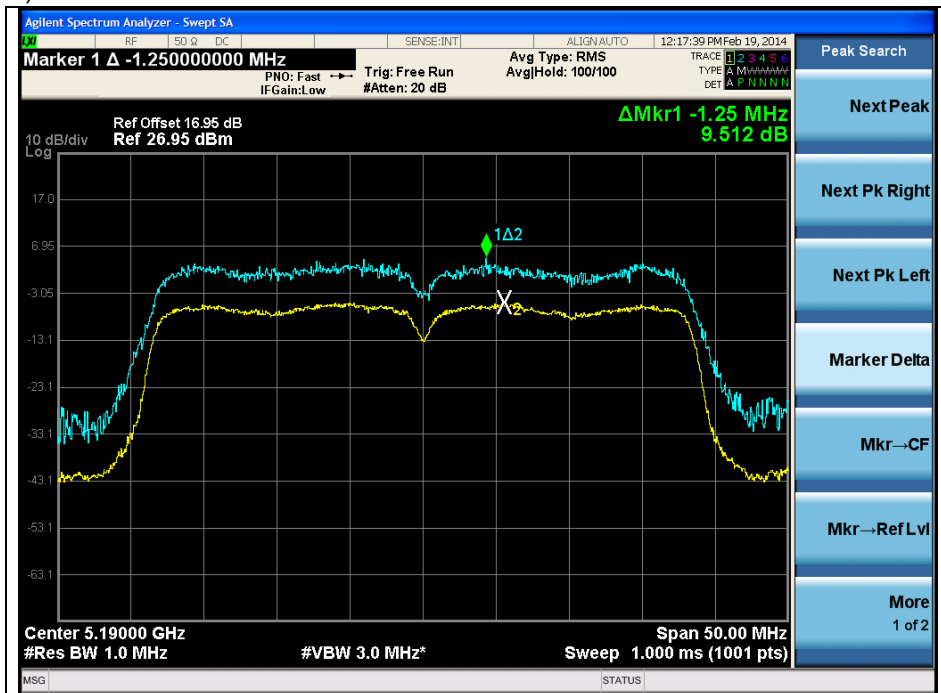

The results shown in this test report refer only to the sample(s) tested unless otherwise stated. This test report cannot be reproduced, except in full, without prior written permission of the Company.

5 190 MHz(MCS6)



5 190 MHz(MCS7)

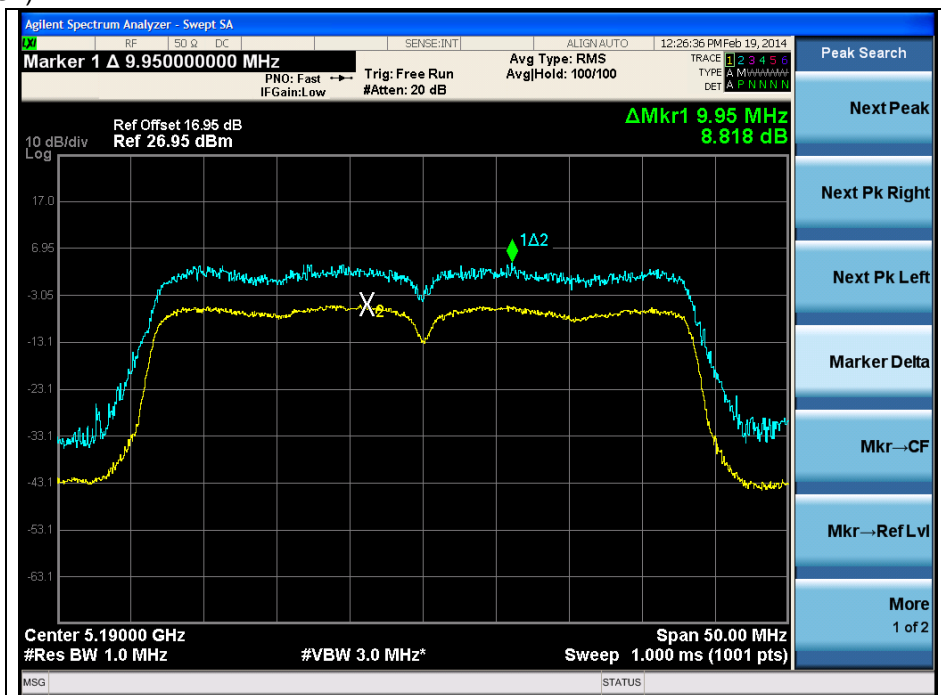

The results shown in this test report refer only to the sample(s) tested unless otherwise stated. This test report cannot be reproduced, except in full, without prior written permission of the Company.

5 190 MHz(MCS8)

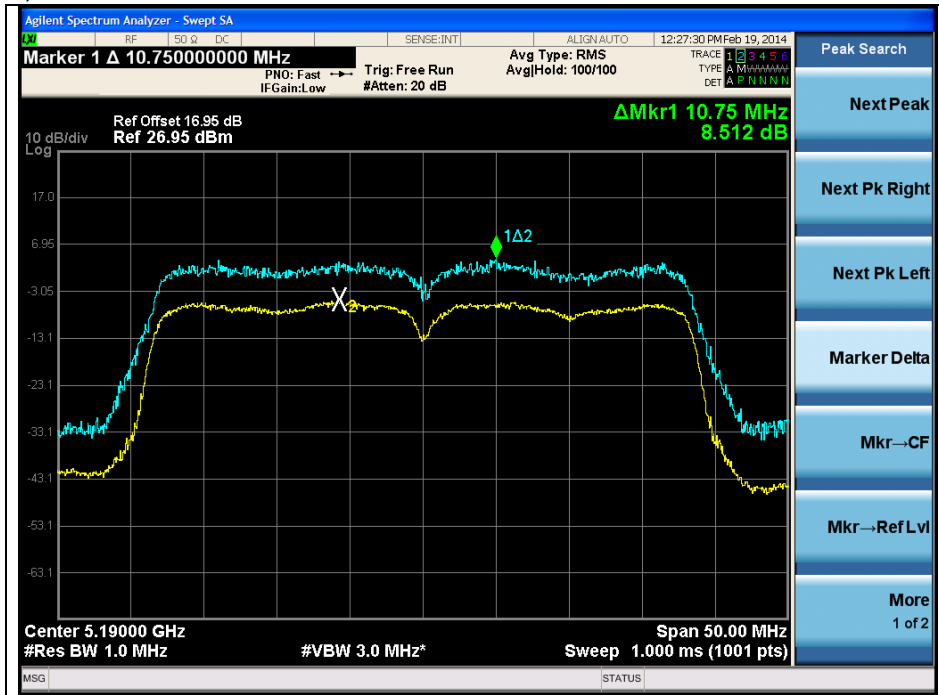

5 190 MHz(MCS9)

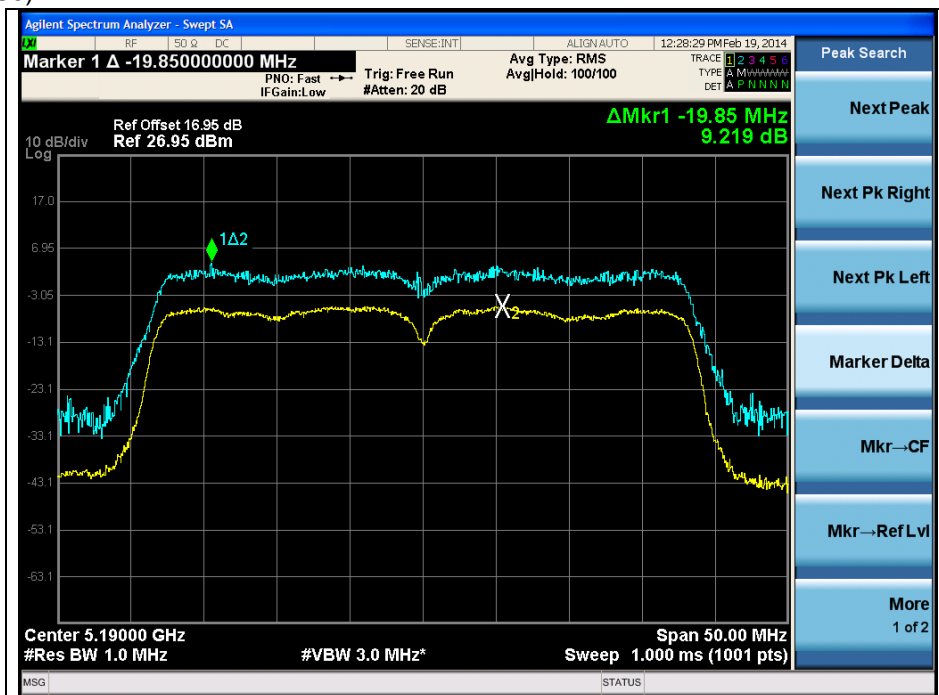

The results shown in this test report refer only to the sample(s) tested unless otherwise stated. This test report cannot be reproduced, except in full, without prior written permission of the Company.

- 11ac\_VHT80

5 210 MHz(MCS0)

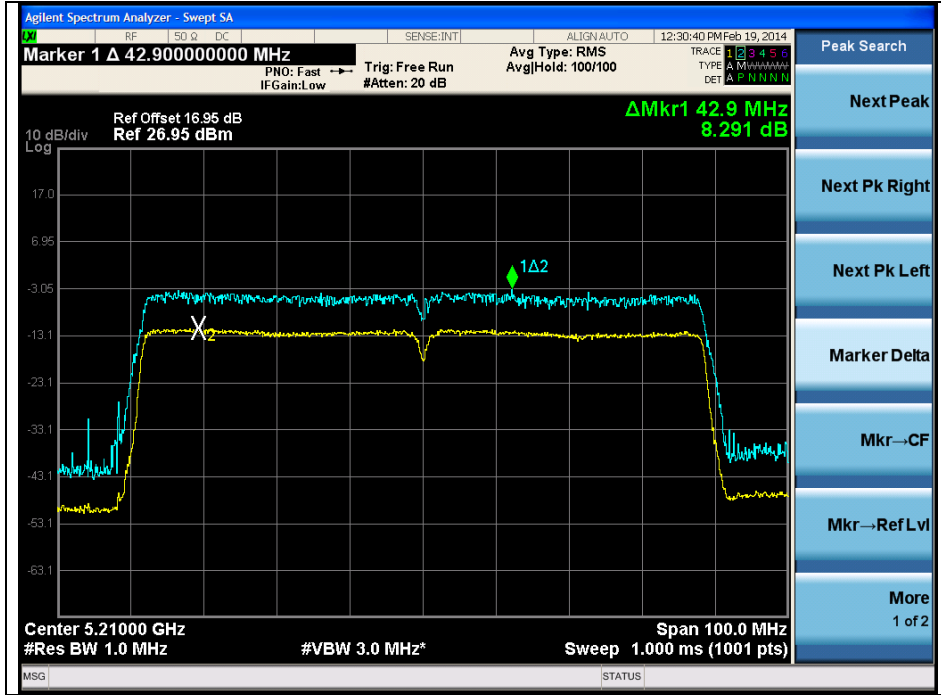

5 210 MHz(MCS1)

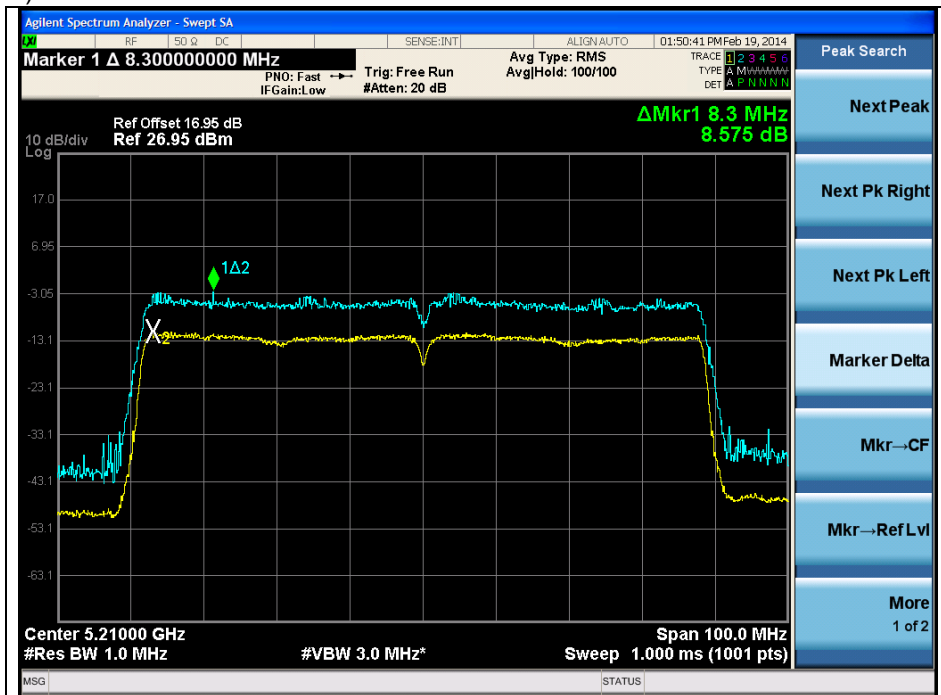

The results shown in this test report refer only to the sample(s) tested unless otherwise stated. This test report cannot be reproduced, except in full, without prior written permission of the Company.

5 210 MHz(MCS2)

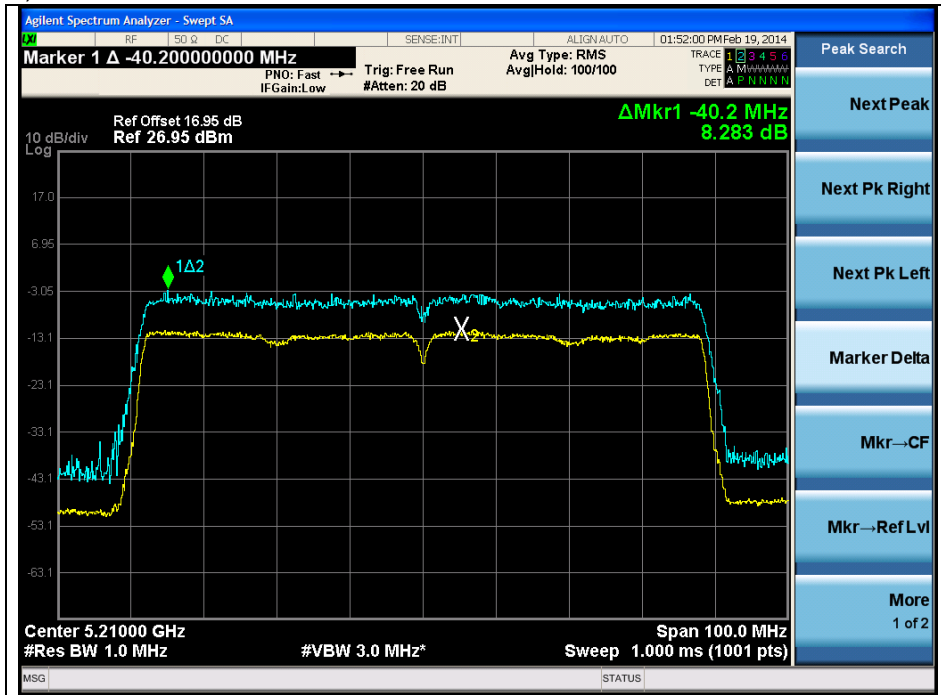

5 210 MHz(MCS3)

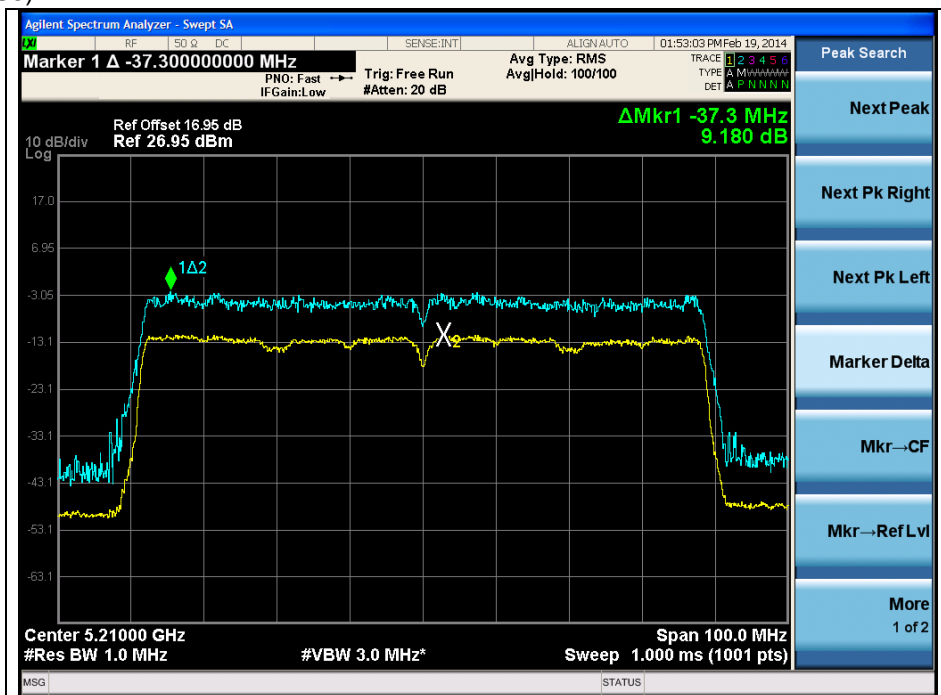

The results shown in this test report refer only to the sample(s) tested unless otherwise stated. This test report cannot be reproduced, except in full, without prior written permission of the Company.

5 210 MHz(MCS4)

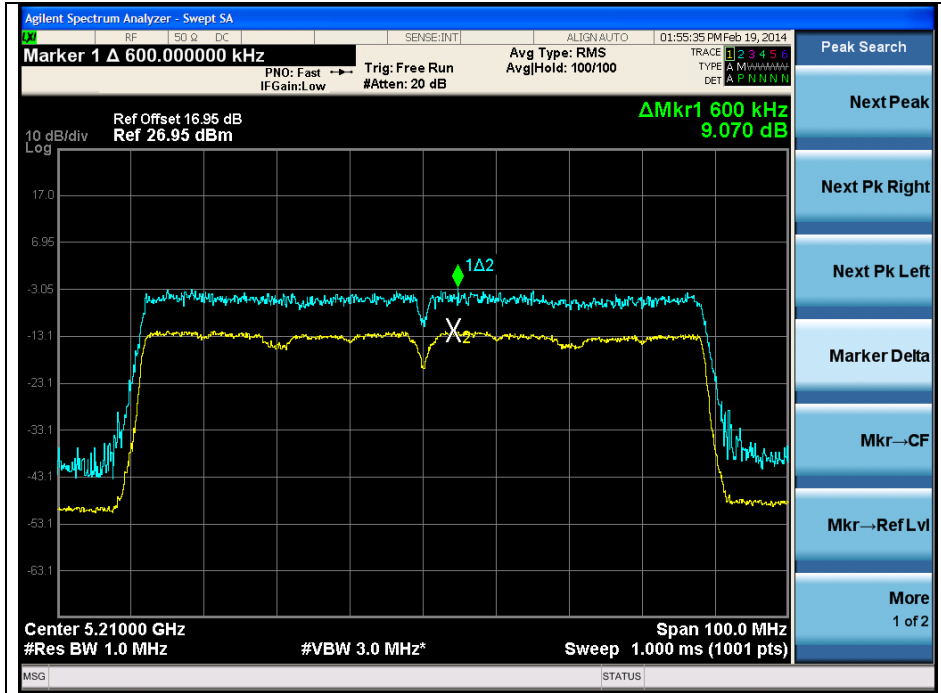

5 210 MHz(MCS5)

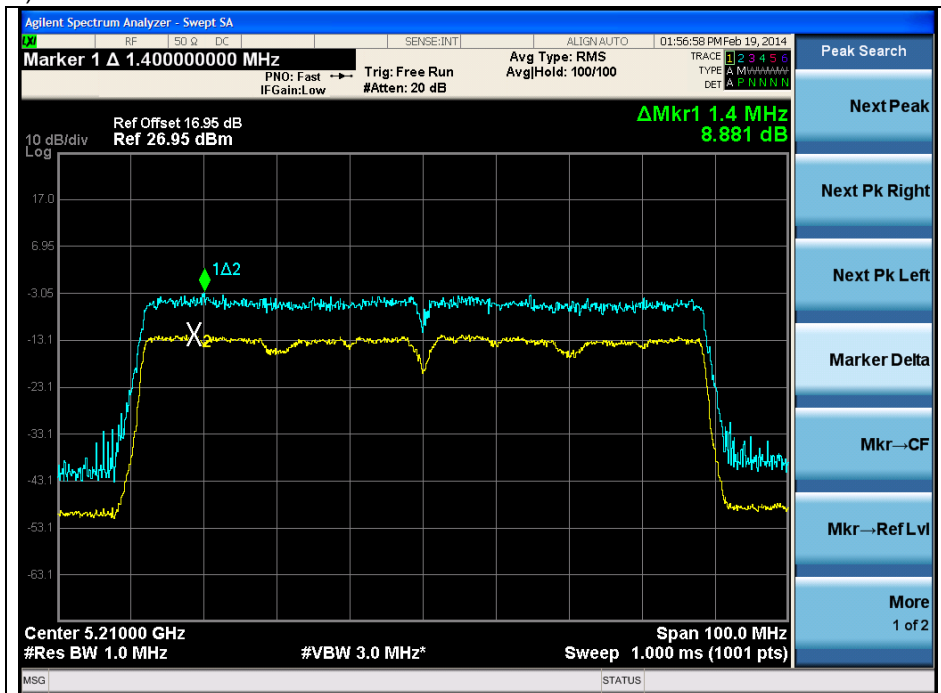

The results shown in this test report refer only to the sample(s) tested unless otherwise stated. This test report cannot be reproduced, except in full, without prior written permission of the Company.

5 210 MHz(MCS6)

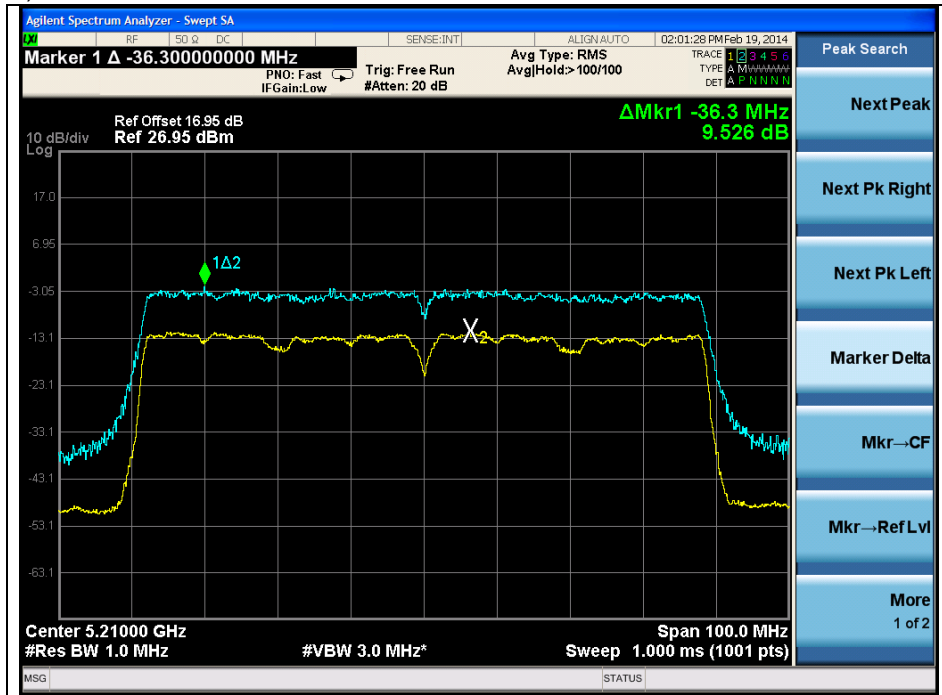

5 210 MHz(MCS7)

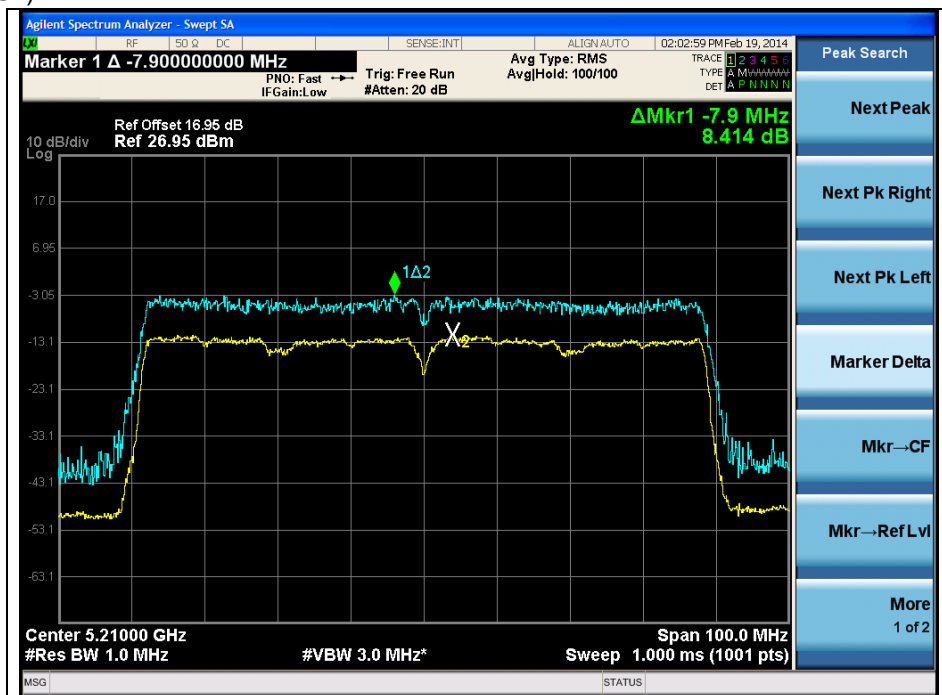

The results shown in this test report refer only to the sample(s) tested unless otherwise stated. This test report cannot be reproduced, except in full, without prior written permission of the Company.

5 210 MHz(MCS8)

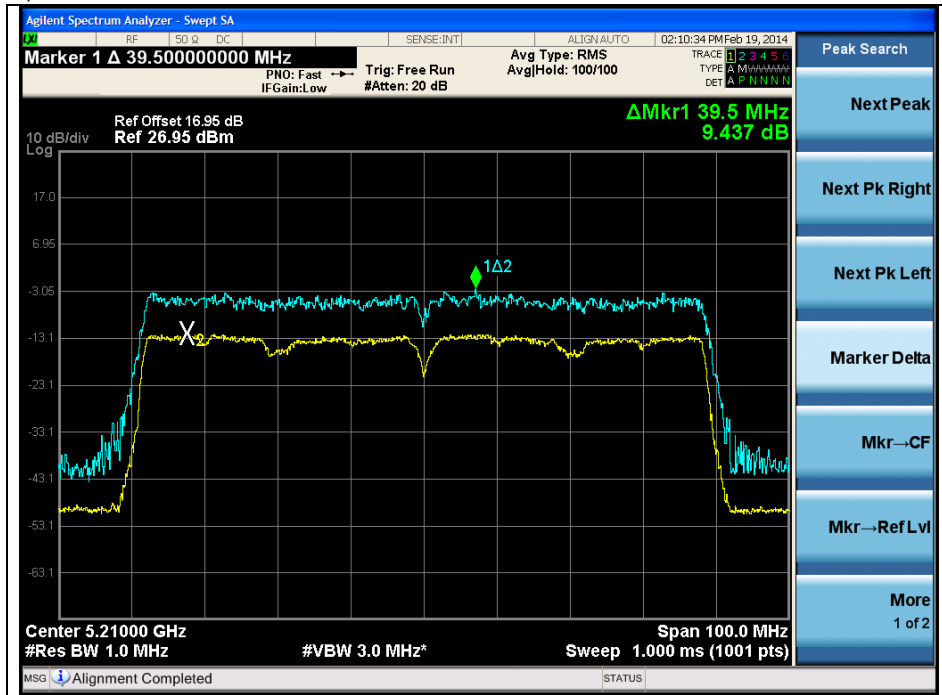

5 210 MHz(MCS9)

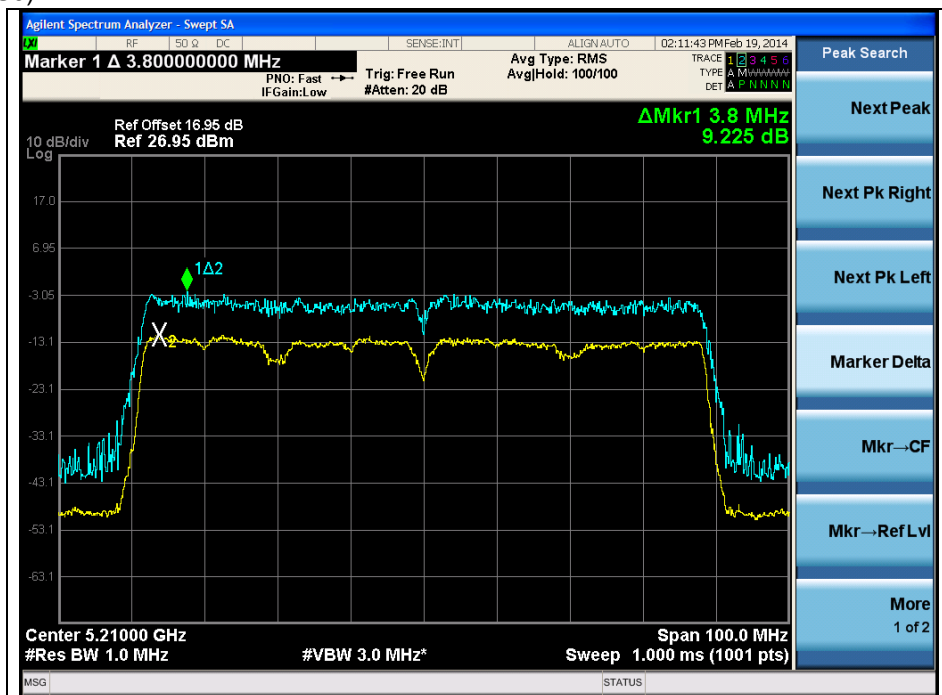

The results shown in this test report refer only to the sample(s) tested unless otherwise stated. This test report cannot be reproduced, except in full, without prior written permission of the Company.

## 7. Transmitter AC Power Line Conducted Emission

### 7.1. Test Setup

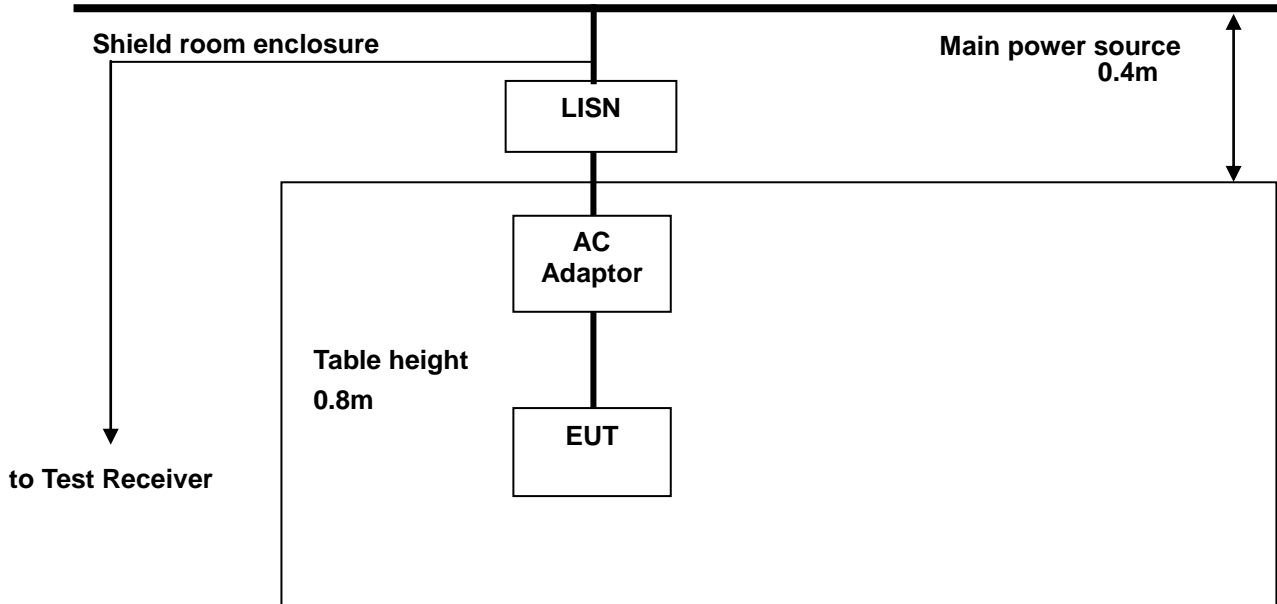

### 7.2. Limit

According to §15.207(a) for an intentional radiator that is designed to be connected to the public utility (AC) power line, the radio frequency voltage that is conducted back onto the AC power line on any frequency or frequencies, within the band 150 kHz to 30 MHz, shall not exceed the limits in the following table, as measured using a 50 uH/50 ohm line impedance stabilization network(LISN).

Compliance with the provision of this paragraph shall on the measurement of the radio frequency voltage between each power line and ground at the power terminal. The lower applies at the boundary between the frequency ranges.

Frequency of Emission (MHz)	Conducted limit (dB $\mu$ V)	
	Quasi-peak	Average
0.15 – 0.50	66 - 56*	56 - 46*
0.50 – 5.00	56	46
5.00 – 30.0	60	50

\* Decreases with the logarithm of the frequency.

The results shown in this test report refer only to the sample(s) tested unless otherwise stated. This test report cannot be reproduced, except in full, without prior written permission of the Company.

---

### 7.3. Test Procedures

All data rates and modes were investigated for this test. The full data for the worst case data rate are reported in this section.

AC line conducted emissions from the EUT were measured according to the dictates of ANSI C63.4-2003

1. The test procedure is performed in a 6.5m × 3.6m × 3.6m (L × W × H) shielded room. The EUT along with its peripherals were placed on a 1.0 m(W) × 1.5 m(L) and 0.8 m in height wooden table and the EUT was adjusted to maintain a 0.4 meter space from a vertical reference plane.
2. The EUT was connected to power mains through a line impedance stabilization network (LISN) which provides 50 ohm coupling impedance for measuring instrument and the chassis ground was bounded to the horizontal ground plane of shielded room.
3. The excess power cable between the EUT and the LISN was bundled. All connecting cables of EUT were moved to find the maximum emission.

---

*The results shown in this test report refer only to the sample(s) tested unless otherwise stated. This test report cannot be reproduced, except in full, without prior written permission of the Company.*

#### 7.4. Test Results (Worst case configuration\_ 11a mode\_6Mbps)

The following table shows the highest levels of conducted emissions on both phase of Hot and Neutral line.

Ambient temperature : (24 ± 2) °C  
 Relative humidity : 47 % R.H.

Frequency range : 0.15 MHz – 30 MHz

Measured Bandwidth : 9 kHz

FREQ. (MHz)	LEVEL(dB $\mu$ V)		LINE	LIMIT(dB $\mu$ V)		MARGIN(dB)	
	Q-Peak	Average		Q-Peak	Average	Q-Peak	Average
0.15	55.4	33.5	H	66.0	56.0	10.6	22.5
0.42	37.6	29.3	H	57.5	47.5	19.9	18.2
2.22	33.1	24.7	H	56.0	46.0	22.9	21.3
15.56	34.0	24.7	H	60.0	50.0	26.0	25.3
21.36	35.8	24.0	H	60.0	50.0	24.2	26.0
0.16	55.2	33.2	N	65.5	55.5	10.3	22.3
0.42	38.4	29.1	N	57.5	47.5	19.1	18.4
2.21	32.8	23.4	N	56.0	46.0	23.2	22.6
15.14	34.2	23.9	N	60.0	50.0	25.8	26.1
21.51	36.7	24.1	N	60.0	50.0	23.3	25.9

Note ;

1. Line ( H ): Hot, Line ( N ): Neutral
2. All modes of operation were investigated and the worst-case emissions are reported using 11a\_6Mbps
3. The limit for Class B device(s) from 150 kHz to 30 MHz are specified in Section of the Title 47 CFR.
4. Traces shown in plot mad using a peak detector and average detector
5. Deviations to the Specifications: None.

*The results shown in this test report refer only to the sample(s) tested unless otherwise stated. This test report cannot be reproduced, except in full, without prior written permission of the Company.*

## Plot of Conducted Power line

Test mode : (Hot)

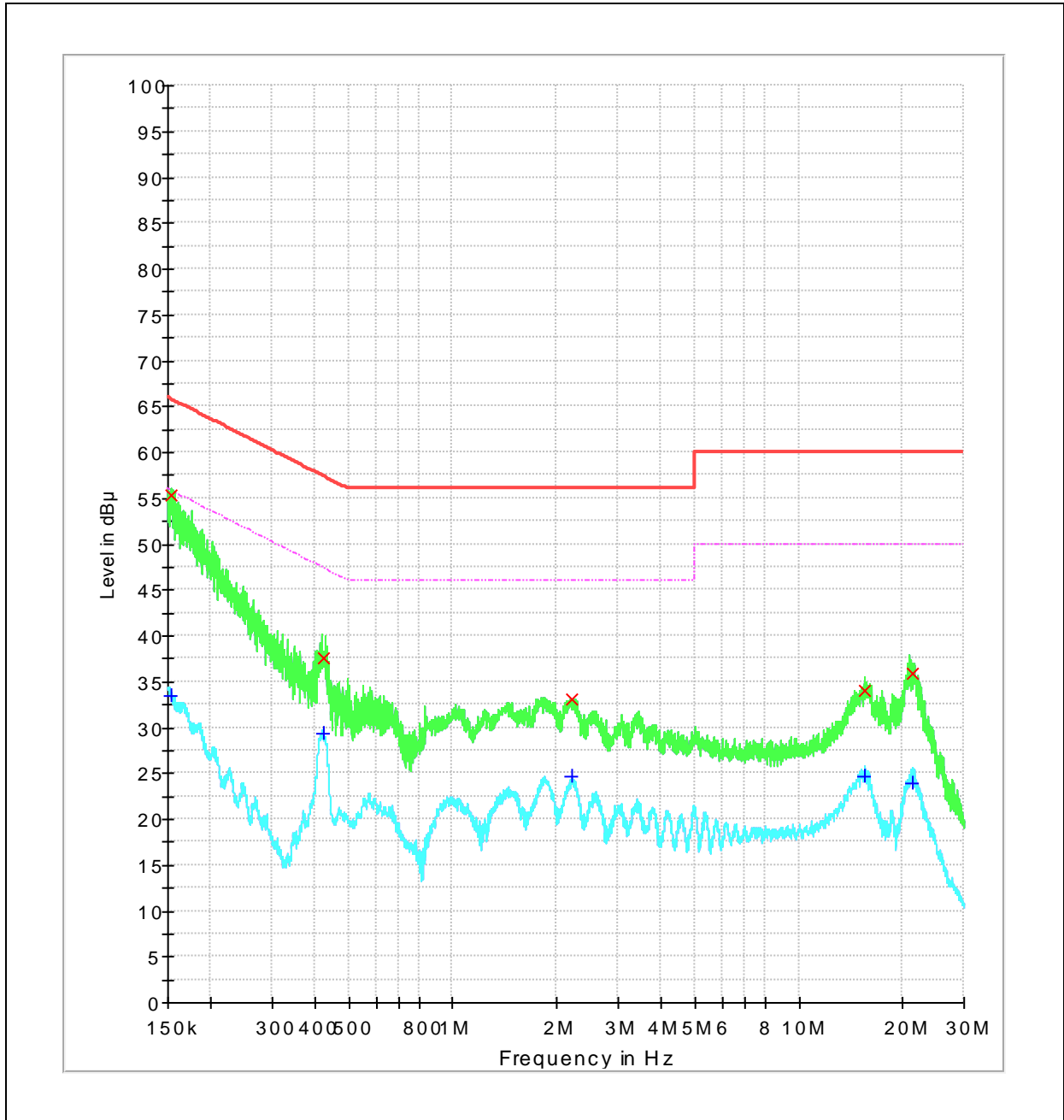

The results shown in this test report refer only to the sample(s) tested unless otherwise stated. This test report cannot be reproduced, except in full, without prior written permission of the Company.

Test mode : (Neutral)

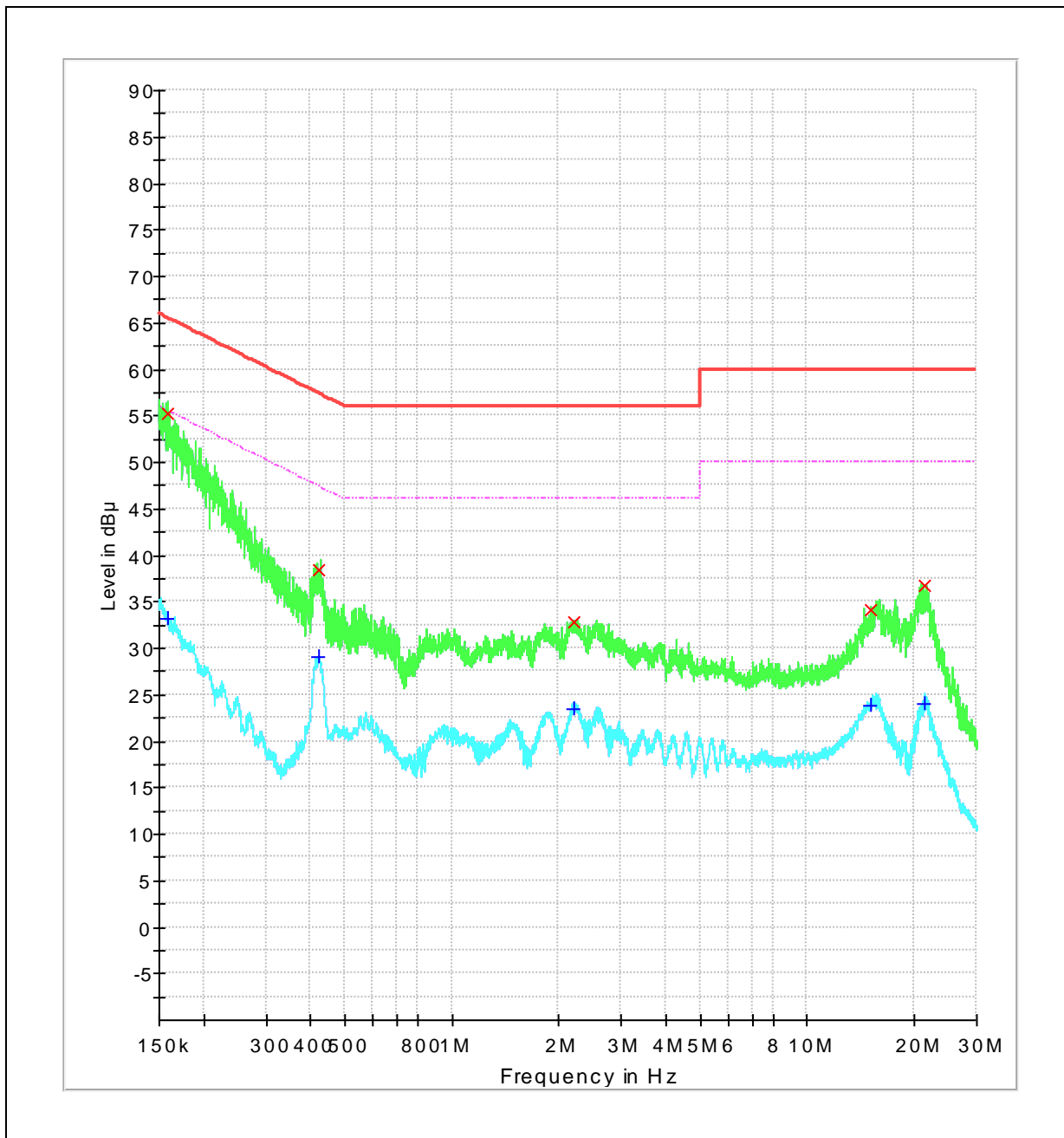

The results shown in this test report refer only to the sample(s) tested unless otherwise stated. This test report cannot be reproduced, except in full, without prior written permission of the Company.