

Nemko Korea Co., Ltd.

159 Osan-ro, Mohyeon-myeon, Cheoin-gu, Yongin-si, Gyeonggi-do, 16885, Republic of Korea

TEL:+82 31 330 1700 FAX:+82 31 322 2332

FCC and IC EVALUATION REPORT FOR CERTIFICATION

Applicant :

Samsung Electronics Co., Ltd.
129, Samsung-ro, Yeongtong-gu,
Suwon-si, Gyeonggi-do, 16677
Republic of Korea.
Attn. : Minhyung Cho

Dates of Issue : November 11, 2016
Test Report No. : NK-16-R-146
Test Site : Nemko Korea Co., Ltd.

FCC ID
IC**A3LWSM520V**
649E-WSM520V**Brand Name****SAMSUNG****Contact Person**

Samsung Electronics Co., Ltd.
129, Samsung-ro, Yeongtong-gu, Suwon-si
Gyeonggi-do, 16677, Republic of Korea.
Minhyung Cho
Telephone No. : +82-31-277-2688

Applied Standard: FCC 47 CFR Part 15.407 and IC RSS-247 Issue 1
Classification: Unlicensed National Information Infrastructure (UNII)
EUT Type: Audio Transceiver

The device bearing the brand name and model specified above has been shown to comply with the applicable technical standards as indicated in the measurement report and was tested in accordance with the measurement procedures specified in ANSI C63.10-2013. The client should not use it to claim product endorsement by TAF or any government agencies. The test results in the report only apply to the tested sample.

I attest to the accuracy of data and all measurements reported herein were performed by me or were made under my supervision and are correct to the best of my knowledge and belief. I assume full responsibility for the completeness of these measurements and vouch for the qualifications of all persons taking them.

Nov. 11. 2016

Tested By : Seungyong Shin
Engineer

Nov 11. 2016

Reviewed By : Deokha Ryu
Technical Manager

Revision History

Rev.	Issue Date	Revisions	Revised By
00	Nov.11, 2016	Initial issue	

TABLE OF CONTENTS

1. Scope	5
2. Introduction (Site Description)	6
2.1 Test facility	6
2.2 Accreditation and listing	7
3. Test Conditions & EUT Information	8
3.1 Operation During Test	8
3.1.1 Table of test channels	8
3.1.2 Table of test modes	8
3.1.3 Table of actual operating channels	9
3.1.4 Additional Information Related to Testing	10
3.2 Support Equipment	11
3.3 Setup Drawing	11
3.4 EUT Information	12
4. Summary of Test Results	13
5. Recommendation / Conclusion	14
6. Antenna Requirements	14
7. Description of Test	15
7.1 Conducted Emissions	15
7.2 Radiated Emissions	16
7.3 26 dB Bandwidth and 99% Occupied Bandwidth	17
7.4 6 dB Bandwidth	18
7.5 Maximum Conducted Output Power	19
7.6 Maximum Power Spectral Density	20
7.7 Duty cycle	21
8. Test Data	22
8.1 Conducted Emissions	22
8.2 Radiated Emissions	25
8.3 26 dB Modulated Bandwidth and 99% Occupied Bandwidth – UNII-3 band	27

8.4	6dB Emission Bandwidth – UNII-3 band	31
8.5	Maximum Conducted Output Power – UNII-3 band	35
8.6	Maximum Power Spectral Density – UNII-3 band	39
8.7	Radiated Spurious Emissions – UNII-3 band	43
8.8	Radiated Band Edge – UNII-3 band	47
9	Test Equipment	50
10	Accuracy of Measurement	51

2. INTRODUCTION

2.1 Test facility

The measurement procedure described in American National Standard for Methods of Measurement of Radio-Noise Emissions from Low-Voltage Electrical and Electronic Equipment in the Range of 9 kHz to 40 GHz (ANSI C63.4-2014), the American National Standard for Testing Unlicensed Wireless Devices (ANSI C63.10-2013) was used in determining radiated and conducted emissions emanating from **Samsung Electronics Co., Ltd. FCC ID : A3LWSM520V** and **IC : 649E-WSM520V**.

These measurement tests were conducted at **Nemko Korea Co., Ltd. EMC Laboratory**.

The site address 159, Osan-ro, Mohyeon-myeon, Cheoin-gu, Yongin-si, Gyeonggi-do, 16885, Republic of Korea.

The area of Nemko Korea Corporation Ltd. EMC Test Site is located in a mountain area at 80 km (48 miles) southeast and Incheon International Airport (Incheon Airport), 30 km (18miles) south-southeast from central Seoul.

It is located in the valley surrounded by mountains in all directions where ambient radio signal conditions are quiet and a favorable area to measure the radio frequency interference on open field test site for the computing and ISM devices manufactures.







The detailed description of the measurement facility was found to be in compliance with the requirements of ANSI C63.4-2014 according to §2.948.



Nemko Korea Co., Ltd.
EMC Lab.
159, Osan-ro, Mohyeon-myeon,
Cheoin-gu, Yongin-si, Gyeonggi-do,
16885, Republic of Korea.
Tel)+82-31-330-1700
Fax)+82-31-322-2332

Fig. 1. The map above shows the Seoul in Korea vicinity area.
The map also shows Nemko Korea Corporation Ltd. EMC Lab. and Incheon Airport.

2.2 Accreditation and listing

Accreditation type		Accreditation number
	CAB Accreditation for DOC	Designation No. KR0026
	KOLAS Accredited Lab. (Korea Laboratory Accreditation Scheme)	Registration No. 155
	Canada IC Registered site	Site No. 2040E
	VCCI registration site(RE/CE/Telecom CE)	Member No. 2118
	EMC CBTL	-
	KCC(RRL)Designated Lab.	Registration No. KR0026

3. TEST CONDITIONS & EUT INFORMATION

3.1 Operation During Test

During the test, the EUT was connected to laptop PC and then a test program supported by manufacture was executed to operate EUT continuously (duty cycle 100%). The operating voltage of EUT was 5 Vdc supplied from JIG board with AC adaptor.

The EUT was tested at the lowest channel, middle channel and the highest channel with the maximum output power in accordance with the manufacturer’s specifications. The worst data were recorded in the report.

The EUT has two antennas which has diversity function(1TX/2RX) and are not working simultaneously.

The EUT was programmed with the following power setting that used during the testing:

Frequency	5725 MHz ~ 5825 MHz
Power setting Level	Default

3.1.1 Table of test channels

Frequency band	Mode	Test Channel (CH)	Frequency (MHz)
5730.35~5820.35MHz	Pi/4DQPSK	2	5730.35
		25	5776.35
		47	5820.35

3.1.2 Table of test modes

Test Items	Modulation	Test Channel (CH)
26 dB Bandwidth	Pi/4DQPSK	2 / 25 / 47
6 dB Bandwidth	Pi/4DQPSK	2 / 25 / 47
Maximum Conducted Output Power	Pi/4DQPSK	2 / 25 / 47
Power Spectral Density	Pi/4DQPSK	2 / 25 / 47
Radiated Spurious Emission	Pi/4DQPSK	2 / 25 / 47
Radiated Band edge Emission	Pi/4DQPSK	2 / 47

3.1.3 Table of actual operating channels

Frequency band	channel	Frequency (MHz)	Remark
UNII-3	0	5726.35	NOT USED
	1	5728.35	
	2	5730.35	
	3	5732.35	USED
	4	5734.35	
	5	5736.35	
	6	5738.35	
	7	5740.35	
	8	5742.35	
	9	5744.35	
	10	5746.35	
	11	5748.35	
	12	5750.35	
	13	5752.35	
	14	5754.35	
	15	5756.35	
	16	5758.35	
	17	5760.35	
	18	5762.35	
	19	5764.35	
	20	5766.35	
	21	5768.35	
	22	5770.35	
	23	5772.35	
	24	5774.35	
	25	5776.35	
	26	5778.35	
	27	5780.35	
	28	5782.35	
	29	5784.35	
	30	5786.35	
	31	5788.35	
32	5790.35		

UNII-3 band	33	5792.35	USED	
	34	5794.35		
	35	5796.35		
	36	5798.35		
	37	5800.35		
	38	5802.35		
	39	5804.35		
	40	5806.35		
	41	5808.35		
	42	5810.35		
	43	5812.35		
	44	5814.35		
	45	5816.35		
	46	5818.35		
	47	5820.35		
	48	5822.35		NOT USED
	49	5824.35		

3.1.4 Additional Information Related to Testing

The cable and attenuator loss from 30MHz to 25GHz was reflected in spectrum analyzer with correction factor for all conducted testing.

99% occupied bandwidth of all channels in UNII-3 band is not extended into DFS band.

The Worst Test Mode

The EUT was tested at the lowest channel, middle channel and the highest channel with the maximum output power in accordance with the manufacturer’s specifications. The worst data were recorded in the report following below.

1. Antenna Port

The EUT has two antennas which are not transmitting simultaneously.

For conducted testing, all of measurements were repeated on each antennas(ANT port 0 and port 1) and results on ANT port 1 are higher output power in UNII-3 band. Therefore, the radiated emissions testing was performed on ANT port 1.

2. Position for Radiated emissions testing

Radiated emissions testing was performed at worst position as a result of pre-scanning.

Pre-scanning was performed by rotating EUT through three orthogonal axes and rotating the receive antenna with horizontal, Vertical polarization. The worst position was determined by worst data.

3.2 Support Equipment

EUT	Samsung Electronics Co., Ltd. Model : WSM520V	S/N: N/A
Laptop Computer	HP. Model : G62-355TU 1.5 m USB shielded cable	FCC DOC S/N : CNF0452FN3
AC/DC Adapter	LITE-ON TECHNOLOGY(CHANGZHOU) CO., LTD. Model : Series PPP009L-E 1.2 m unshielded power cable	FCC DOC S/N : WBGST0A3UZOFQ6

3.3 Setup Drawing

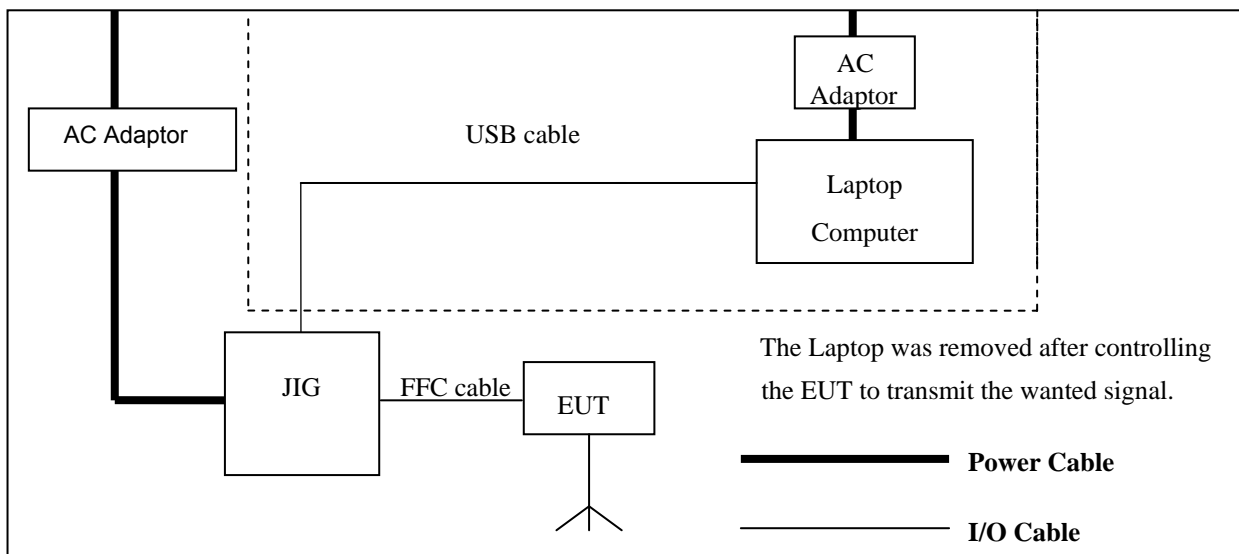

3.4 EUT Information

The EUT is the **Samsung Audio Module FCC ID: A3LWSM520V , IC: 649E- WSM520V.**

Specifications:

EUT Type	Audio Transceiver
Model Name	WSM520V
Brand Name	SAMSUNG
RF Frequency	5730.35 MHz ~ 5820.35 MHz
Maximum Output Power (Conducted)	14.85 dBm
Channels	46 ch
Modulation	Pi/4DQPSK
Antenna Gain (peak)	2.2 dBi
Antenna Setup	1TX / 2RX
EUT Rated Voltage:	5 Vdc
EUT Test Voltage:	5 Vdc
Temperature Range	5 °C ~ +35 °C
Size (W x L x H)	40 mm x 26 mm x 3 mm
Weight	5 g
H/W Status	-
S/W Status	-
Remarks	-

4. SUMMARY OF TEST RESULTS

The EUT has been tested according to the following specification:

Name of Test	FCC Paragraph No.	IC Paragraph No.	Result	Remark
Conducted Emission	15.207	RSS-GEN Issue 4 8.8	Complies	
Radiated Emission	15.209	RSS-GEN Issue 4 8.9	Complies	
26 dB Spectrum Bandwidth and 99% Occupied bandwidth	15.407(a)	RSS-247 Issue 1 6.2	Complies	
6 dB Bandwidth	15.407(e)	RSS-247 Issue 1 6.2	Complies	
Maximum Conducted Output Power	15.407(a)	RSS-247 Issue 1 6.2	Complies	
Power Spectral Density	15.407(a)	RSS-247 Issue 1 6.2	Complies	
Radiated Spurious Emission	15.407(b)	RSS-247 Issue 1 6.2	Complies	
Maximum Permissible Exposure	1.1307(b)	RSS-102	Complies	

5. RECOMMENDATION/CONCLUSION

The data collected shows that the **Samsung Audio Transceiver FCC ID: A3LWSM520V, IC: 649E- WSM520V** is in compliance with Part 15.407 of the FCC Rule and RSS-247 Issue 1 of the IC specification.

6. ANTENNA REQUIREMENTS

§15.203 of the FCC Rules part 15 Subpart C

: An intentional radiator shall be designed to ensure that no antenna other than that furnished by the responsible party shall be used with the device. The use of a permanently attached antenna or of an antenna that uses a unique coupling to the intentional radiator shall be considered sufficient to comply with the provisions of this section.

The antenna of the **Samsung Audio Transceiver FCC ID: A3LWSM520V, IC: 649E- WSM520V** is permanently attached and there are no provisions for connection to an external antenna. It complies with the requirement of §15.203.

7. DESCRIPTION OF TESTS

7.1 Conducted Emissions

The Line conducted emission test facility is located inside a 4 x 7 x 2.5 meter shielded enclosure. It is manufactured by EM engineering. The shielding effectiveness of the shielded room is in accordance with MIL-STD-285 or NSA 65-6. A 1 m x 1.5 m wooden table 0.8 m height is placed 0.4 m away from the vertical wall and 1.5 m away from the side of wall of the shielded room Rohde & Schwarz (ESH3-Z5) and (ESH2-Z5) of the 50 ohm/50 μ H Line Impedance Stabilization Network (LISN) are bonded to the shielded room. The EUT is powered from the Rohde & Schwarz LISN (ESH3-Z5) and the support equipment is powered from the Rohde & Schwarz LISN (ESH2-Z5). Power to the LISNs are filtered by high-current high insertion loss Power line filters. The purpose of filter is to attenuate ambient signal interference and this filter is also bonded to shielded enclosure. All electrical cables are shielded by tinned copper zipper tubing with inner diameter of 1 / 2 ”.

If DC power device, power will be derived from the source power supply it normally will be powered from and this supply lines will be connected to the LISNs, All interconnecting cables more than 1 meter were shortened by non inductive bundling (serpentine fashion) to a 1 meter length.

Sufficient time for EUT, support equipment, and test equipment was allowed in order for them to warm up to their normal operating condition. The RF output of the LISN was connected to the spectrum analyzer to determine the frequency producing the maximum EME from the EUT.

The spectrum was scanned from 150 kHz to 30 MHz with 200 msec sweep time.

The frequency producing the maximum level was re-examined using the EMI test receiver. (Rohde & Schwarz ESCS30). The detector functions were set to CISPR quasi-peak mode & average mode. The bandwidth of receiver was set to 9 kHz. The EUT, support equipment, and interconnecting cables were arranged and manipulated to maximize each EME emission.

Each emission was maximized by; switching power lines; varying the mode of operation or resolution; clock or data exchange speed; scrolling H pattern to the EUT and of support equipment, and powering the monitor from the floor mounted outlet box and computer aux AC outlet, if applicable; whichever determined the worst case emission.

Each EME reported was calibrated using the R&S signal generator.

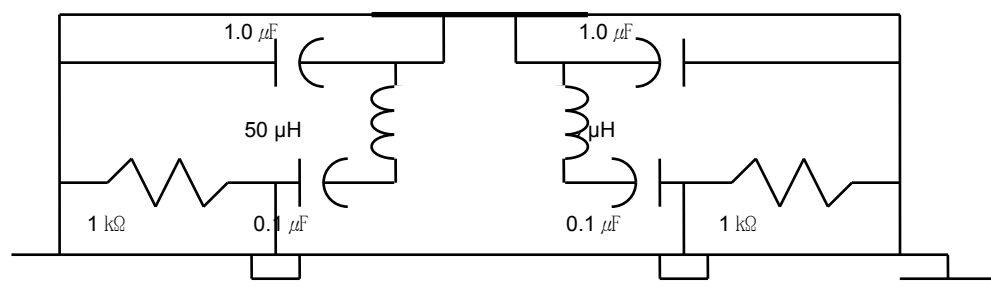

Fig. 2. LISN Schematic Diagram

7.2 Radiated Emissions

The measurement was performed at the test site that is specified in accordance with ANSI C63.10-2013.

The spurious emission was scanned from 9 kHz to 30 MHz using Loop Antenna(Rohde&Schwarz, HFH2-Z2) and 30 to 1000 MHz using Trilog broadband test antenna(Schwarzbeck, VULB 9163). Above 1 GHz, Horn antenna (Schwarzbeck BBHA 9120D: up to 18 GHz, Q-par Angus QSH20S20 : 18 to 26.5 GHz, QSH22K20: up to 40 GHz) was used.

For emissions testing at below 1GHz, The test equipment was placed on turntable with 0.8 m above ground. For emission measurements above 1 GHz, The test equipment was placed on turntable with 1.5 m above ground. Sufficient time for the EUT, support equipment, and test equipment was allowed in order for them to warm up to their normal operating condition. The EUT, cable, wire arrangement and mode of operation that has the highest amplitude relative to the limit was selected. Then, the turn table was rotated from 0° to 360° and an antenna mast was moved from 1 m to 4 m height to maximize the suspected highest amplitude signal. The final maximized level was recorded.

Unwanted emissions in the restricted bands

At frequencies below 1000 MHz, measurements performed using the CISPR quasi-peak detection.

At frequencies above 1000 MHz, measurements performed using the peak and average measurement procedures described in KDB “789033 D02 General UNII Test Procedures New Rules v01r03” in section G)5) and G)6). Peak emission levels was measured by setting the analyzer RBW = 1 MHz, VBW = 3 MHz, Detector = Peak, Trace mode = max hold. Average emission levels was measured using the “Method VB” by setting the analyzer RBW = 1 MHz, VBW = 1 kHz (VBW ≤ RBW/100), Detector = Peak , if the EUT is configured to transmit with duty cycle ≥ 98 percent. When the duty cycle ≤ 98 percent, VBW ≥ 1/T(T = minimum transmission duration over which the transmitter is on) was used.

Unwanted emissions outside of the restricted bands

At frequencies below 1000 MHz, measurements performed using the CISPR quasi-peak detection.

At frequencies above 1000 MHz, measurements performed using the peak measurement procedures described in KDB “789033 D02 General UNII Test Procedures New Rules v01r03” in section G)5). Peak emission levels was measured by setting the analyzer RBW = 1 MHz, VBW = 3 MHz, Detector = Peak, Trace mode = max hold. If the transmission is not continuous, the time required for the trace to stabilize will increase by a factor of approximately 1/x, where x is the duty cycle.

7.3 26 dB Bandwidth and 99% Occupied bandwidth

Test Setup

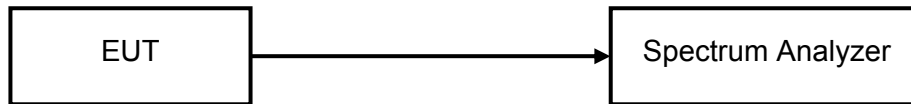

Test Procedure

EUTs 26 dB bandwidth is measured at low, middle, high channels with a spectrum analyzer connected to the antenna terminal while the EUTs operating at its maximum power control level.

The spectrum analyzer setting is as follows.

RBW = approximately 1 % of the emission bandwidth

VBW \geq 3 x RBW

Detector = Peak

Trace mode = max hold

Sweep = auto couple.

The bandwidth measurement function on the spectrum analyzer is used to measure the 26 dB bandwidth and 99% occupied bandwidth.

7.4 6 dB Bandwidth

Test Setup

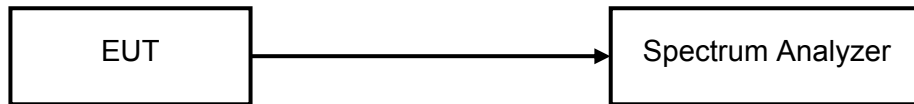

Test Procedure

EUTs 6 dB bandwidth is measured at low, middle, high channels with a spectrum analyzer connected to the antenna terminal while the EUTs operating at its maximum power control level.

The spectrum analyzer setting is as follows.

RBW = 100 kHz

VBW > 3 x RBW

Detector = Peak

Trace mode = max hold

Sweep = auto couple

The bandwidth measurement function on the spectrum analyzer is used to measure the 6 dB bandwidth.

7.5 Maximum Conducted Output Power (average)

Test Setup

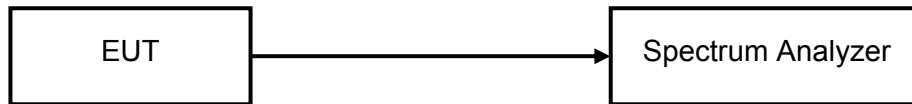

Test Procedure

EUTs Maximum Conducted Output Power is measured at low, middle, high channels with a spectrum analyzer connected to the antenna terminal while the EUTs operating at its maximum power control level.

The spectrum analyzer setting is as follows.

Measure the duty cycle

Span = encompass the EBW of the signal.

RBW = 1 MHz

VBW \geq 3 MHz

Number of points in sweep \geq 2 Span / RBW

Sweep time = auto

Detector = RMS

Trace average at least 100 traces in power averaging mode

The band power measurement function on the spectrum analyzer is used to measure the Maximum conducted output power.

Add $10 \log(1/x)$, where x is the duty cycle.

7.6 Maximum Power Spectral Density (average)

Test Setup

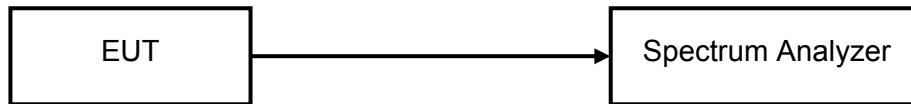

Test Procedure

EUTs Maximum Power Spectral Density is measured at low, middle, high channels with a spectrum analyzer connected to the antenna terminal while the EUTs operating at its maximum power control level.

Measure the duty cycle.

The spectrum analyzer setting is as follows.

Span = encompass the EBW of the signal.

RBW = 500 kHz

VBW \geq 2 MHz

Number of points in sweep \geq 2 Span / RBW

Sweep time = auto

Detector = RMS

Trace average at least 100 traces in power averaging mode

The peak search function on the spectrum analyzer is used to find the peak of the spectrum.

Add $10 \log(1/x)$, where x is the duty cycle.

7.7 Duty Cycle

Test Setup

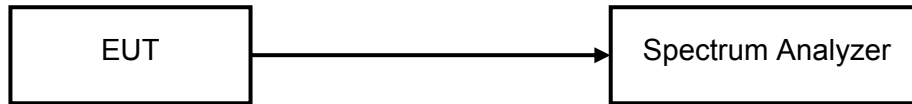

Test Procedure

EUTs duty cycle are measured at middle channel with a spectrum analyzer connected to the antenna terminal while the EUTs operating at its maximum power control level. The spectrum analyzer setting is as follows.

Center frequency = Center frequency of the transmission

Span = zero

RBW = 8 MHz

VBW = 8 MHz

Detector = peak

Sweep time = at least 30ms

Trace mode = view

The marker function on the spectrum analyzer is used to determine the duty cycle.

Following is the worst result of the duty cycle measurements according to the above test procedure

UNII-3 band

	On time (ms)	On + Off time (ms)	Duty Cycle (%)	Duty Factor (dB)
5730.35~5820.35MHz	-	-	100	N.A

8. TEST DATA

8.1 Conducted Emissions

FCC §15.207, RSS-Gen Issue 4 8.8

Result

Frequency (MHz)	Level (dB μ V)		*) Factor (dB)	**) Line	Limit (dB μ V)		Margin (dB)	
	Q-Peak	Average			Q-Peak	Average	Q-Peak	Average
0.15	46.1	21.6	10.79	N	66.0	56.0	19.9	34.4
0.17	46.0	20.4	10.77	L	65.0	55.0	19.0	34.6
9.00	27.3	26.8	10.69	N	60.0	50.0	32.7	23.2
12.00	38.0	37.8	10.80	N	60.0	50.0	22.0	12.2
21.00	30.5	30.4	11.09	N	60.0	50.0	29.5	19.6
27.00	41.0	41.0	11.34	N	60.0	50.0	19.0	9.0

Line Conducted Emissions Tabulated Data

Notes:

1. Measurements using CISPR quasi-peak mode & average mode.
2. All modes of operation were investigated and the worst -case emission are reported.
See attached Plots.
3. *) Factor = LISN + Cable Loss
4. **) LINE : L = Line , N = Neutral
5. The limit is on the FCC §15.207 and IC RSS-Gen Issue 4 8.8

PLOTS OF EMISSIONS

- Conducted Emission (Line)**

Nemko Korea

31 Oct 2016 08:30

Conducted Emissions

EUT: EUT
 Manuf: Samsung Electronics Co.,Ltd.
 Op Cond: a.c. 120 V 60 Hz (Host Voltage)
 Operator: Seungyoung Shin
 Test Spec: FCC Part 15.407
 Comment: MODEL : WSM520V
 LINE :Line - PE
 Result File: L.dat : FCC Part 15.407

Scan Settings			Receiver Settings					
Start	Stop	Step	IF BW	Detector	M-Time	Atten	Preamp	OpRge
150kHz	30MHz	3.9063kHz	9kHz	PK+AV	20msec	20 dB	OFF	60dB

Transducer	No.	Start	Stop	Name
	1	150kHz	30MHz	ESH3_Z5_Line

Final Measurement: Detectors: X QP / + AV
 Meas Time: 1sec
 Subranges: 8
 Acc Margin: 60 dB

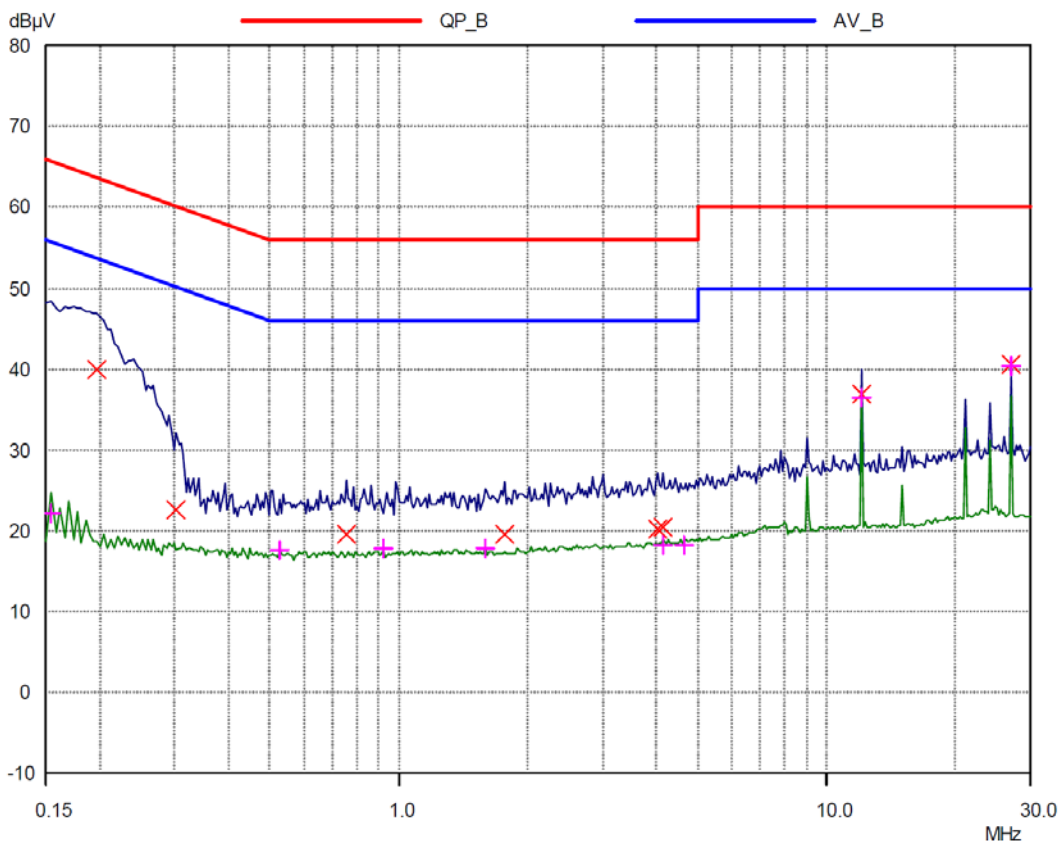

PLOTS OF EMISSIONS

- Conducted Emission (Neutral)**

Nemko Korea

31 Oct 2016 08:51

Conducted Emissions

EUT: EUT
 Manuf: Samsung Electronics Co.,Ltd.
 Op Cond: a.c. 120 V 60 Hz (Host Voltage)
 Operator: Seungyoung Shin
 Test Spec: FCC Part 15.407
 Comment: MODEL : WSM520V
 LINE :Neutral - PE
 Result File: N.dat : FCC Part 15.407

Scan Settings (1 Range)

Frequencies			Receiver Settings						
Start	Stop	Step	IF BW	Detector	M-Time	Atten	Preamp	OpRge	
150kHz	30MHz	3.9063kHz	9kHz	PK+AV	20msec	20 dB	OFF	60dB	

Transducer	No.	Start	Stop	Name
	1	150kHz	30MHz	ESH3_Z5_Neutral

Prescan Measurement: Detectors: X PK / + AV
 Meas Time: see scan settings
 Subranges: 8
 Acc Margin: 60 dB

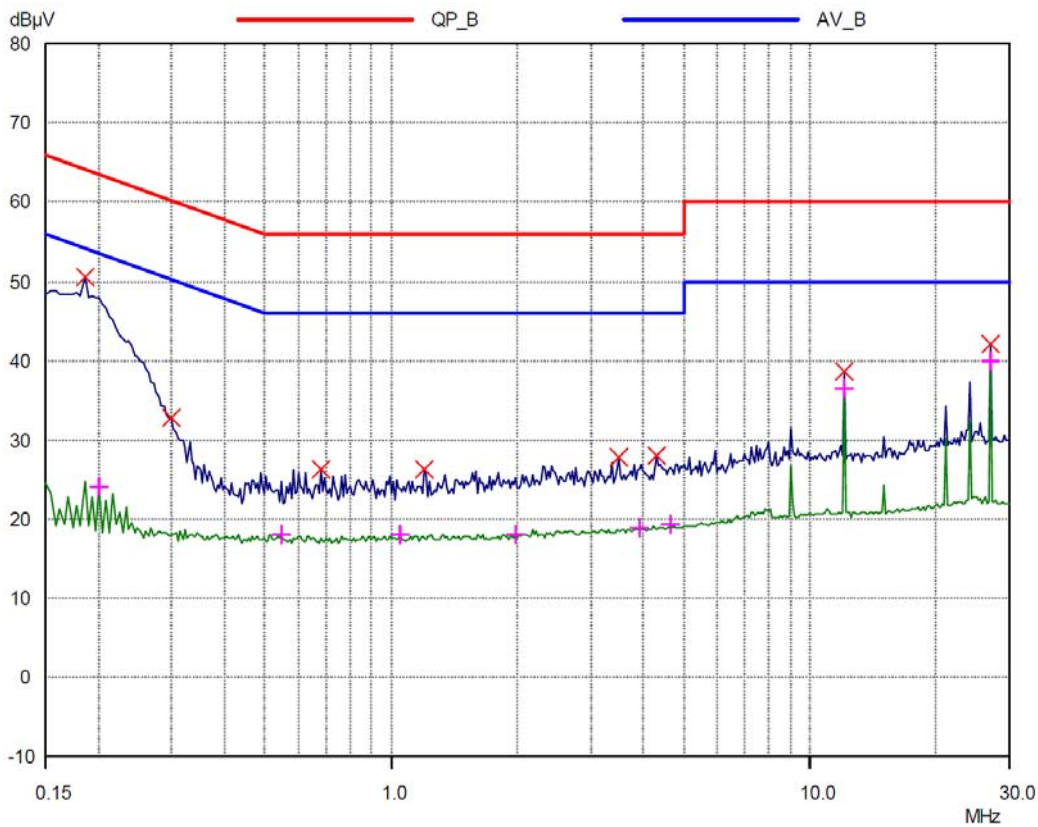

TEST DATA

8.2 Radiated Emissions

FCC §15.209, RSS-Gen Issue 4 8.9

Result

Frequency (MHz)	Reading (dB μ V/m)	Pol* (H/V)	Antenna Heights (cm)	Turntable Angles (°)	AF+CL+Amp (dB)**	Result (dB μ V/m)	Limit (dB μ V/m)	Margin (dB)
35.97	43.50	V	100	330	-22.5	21.0	40.0	19.0
59.97	43.60	V	100	228	-22.3	21.3	40.0	18.7
83.98	50.60	V	120	241	-26.3	24.3	40.0	15.7
356.36	45.60	H	100	12	-16.4	29.2	46.0	16.8
552.01	38.50	H	212	354	-10.6	27.9	46.0	18.1
948.06	35.20	H	100	140	-4.2	31.0	46.0	15.0

Radiated Measurements at 3meters

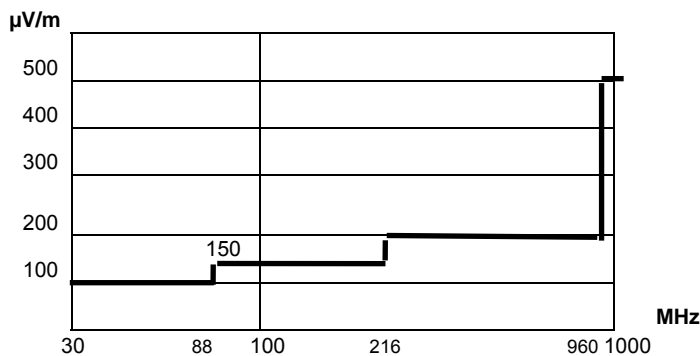

Fig. 3. Limits at 3 meters

Notes:

1. All modes were measured and the worst-case emission was reported.
2. The radiated limits are shown on Figure 3. Above 1GHz the limit is 500 μ V /m.
3. *Pol. H = Horizontal, V = Vertical
4. **AF + CL + Amp. = Antenna Factor + Cable Loss + Amplifier.
5. Measurements using CISPR quasi-peak mode below 1 GHz.
6. The radiated emissions testing were made by rotating the receive antenna with horizontal, Vertical polarization. The worst date was recorded.
7. The highest channel (5820.35MHz) is the worst case channel.
8. No emission found between lowest internal used/generated frequency to 30MHz (9kHz~30MHz).
9. The limit is on the FCC §15.209 and RSS-Gen Issue4 8.9

PLOTS OF EMISSIONS

Worst Case : 5820.35 MHz(below 1GHz)

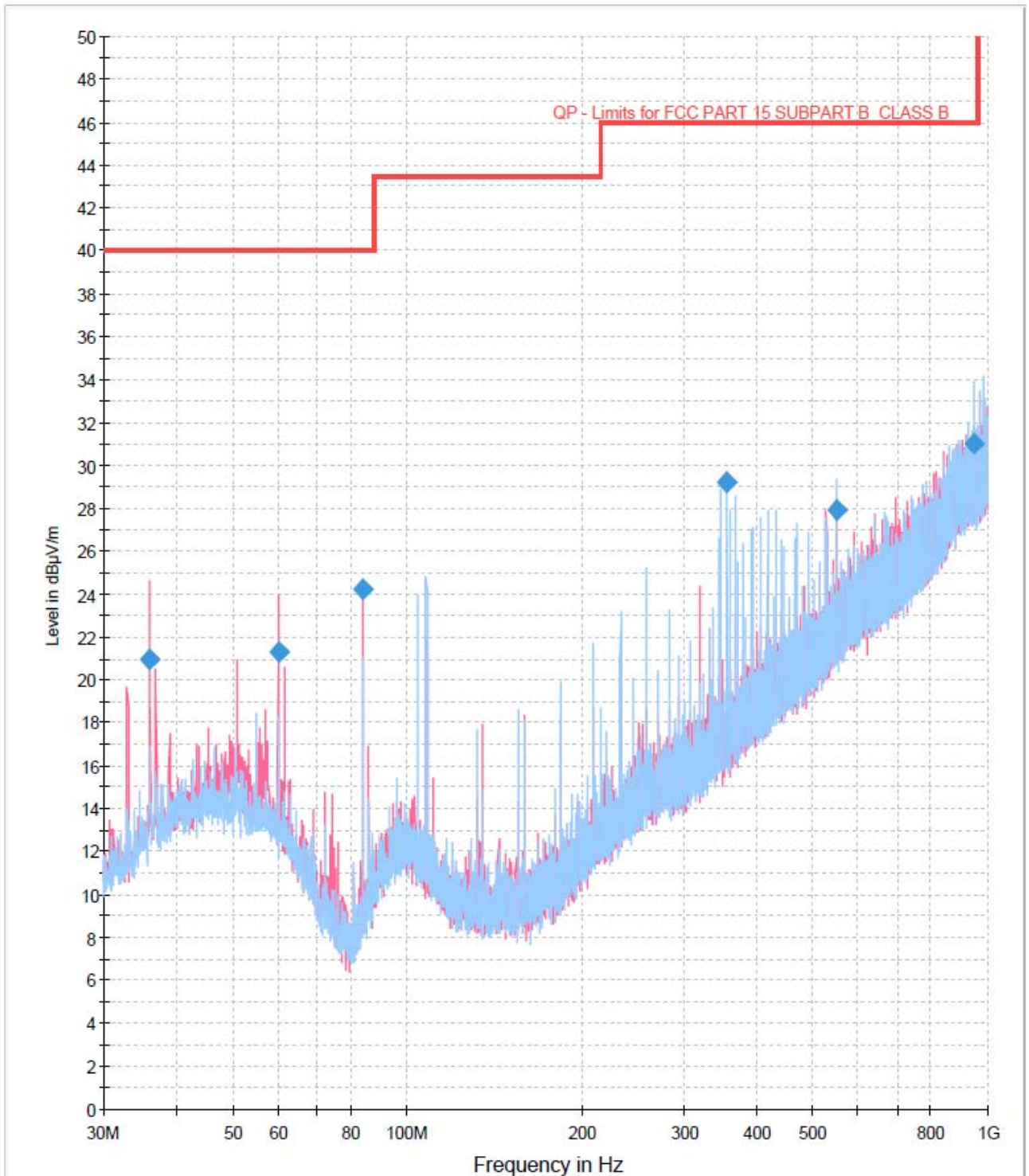

TEST DATA

8.3 26 dB Bandwidth and 99 % Occupied bandwidth – UNII-3 band

FCC §15.407(a), RSS-247 Issue 1 6.2

Test Mode : Set to Lowest channel, Middle channel and Highest channel

Result

Channel	Frequency (MHz)	26 dB Bandwidth (MHz)		99% Occupied Bandwidth (MHz)	
		Ant 0	Ant 1	Ant 0	Ant 1
Low	5730.35	2.48	2.49	1.93	1.93
Middle	5776.35	2.48	2.48	1.94	1.93
High	5820.35	2.48	2.49	1.93	1.93

PLOTS OF EMISSIONS

Ant 0

26 dB Bandwidth, Lowest Channel (5730.35 MHz)

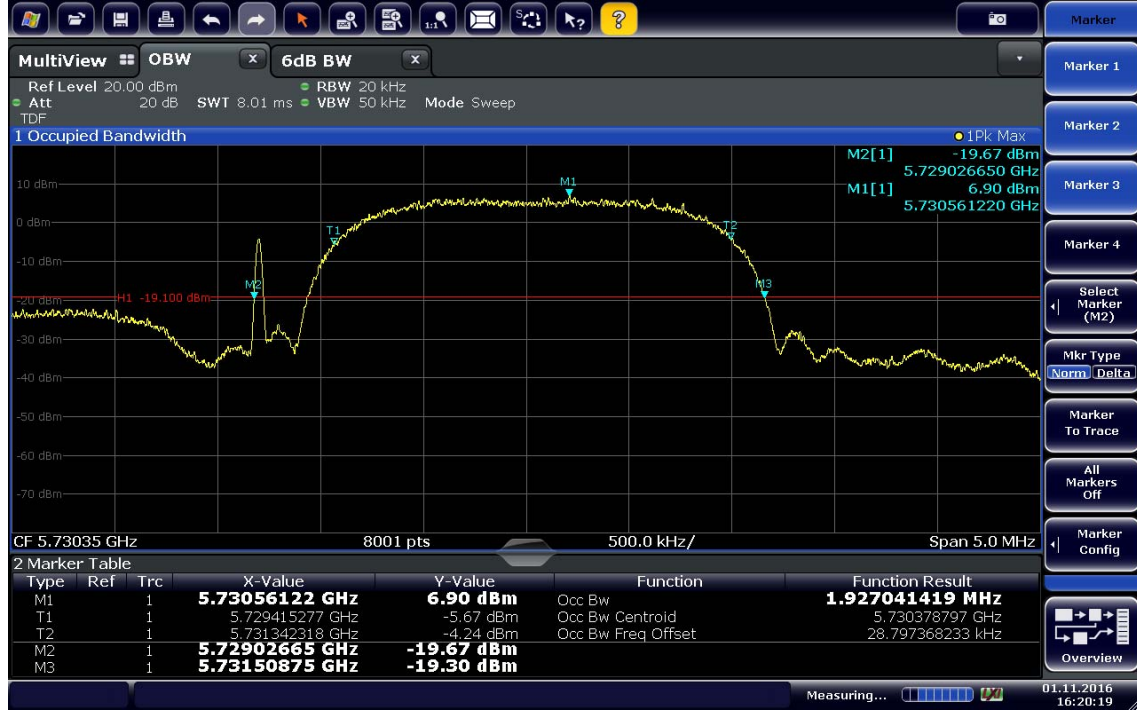

26 dB Bandwidth, Middle Channel (5776.35 MHz)



PLOTS OF EMISSIONS

26 dB Bandwidth, Highest Channel (5820.35 MHz)



Ant 1

26 dB Bandwidth, Lowest Channel (5730.35 MHz)

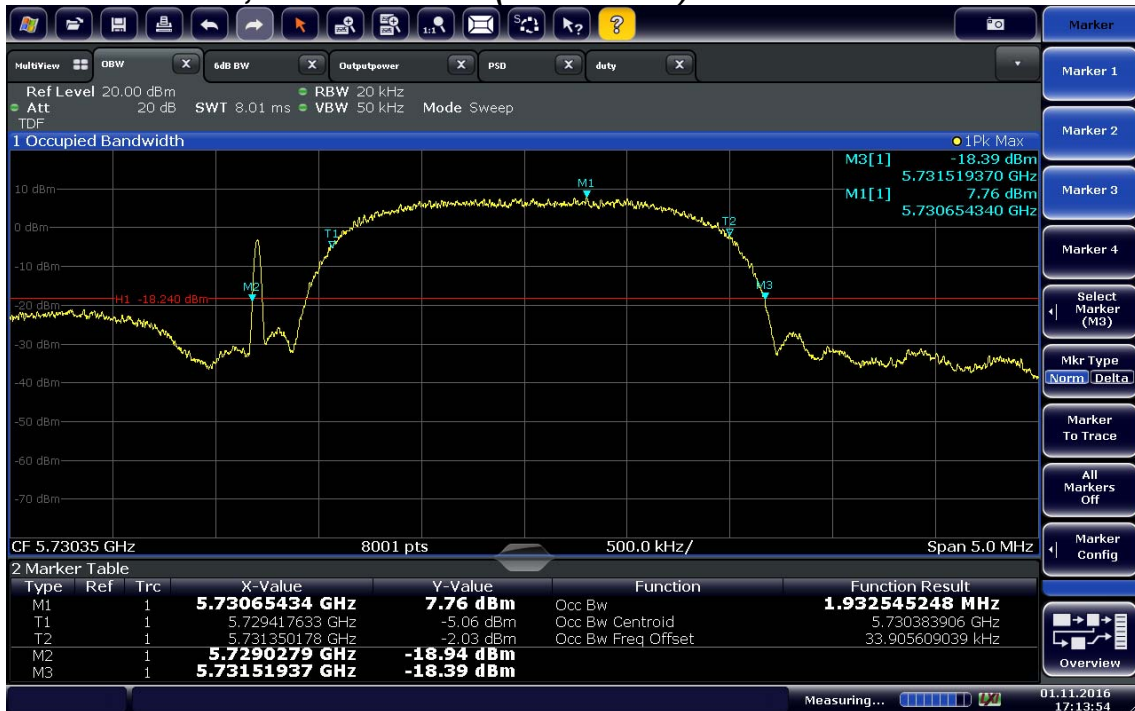

PLOTS OF EMISSIONS

26 dB Bandwidth, Middle Channel (5776.35 MHz)



26 dB Bandwidth, Highest Channel (5820.35 MHz)

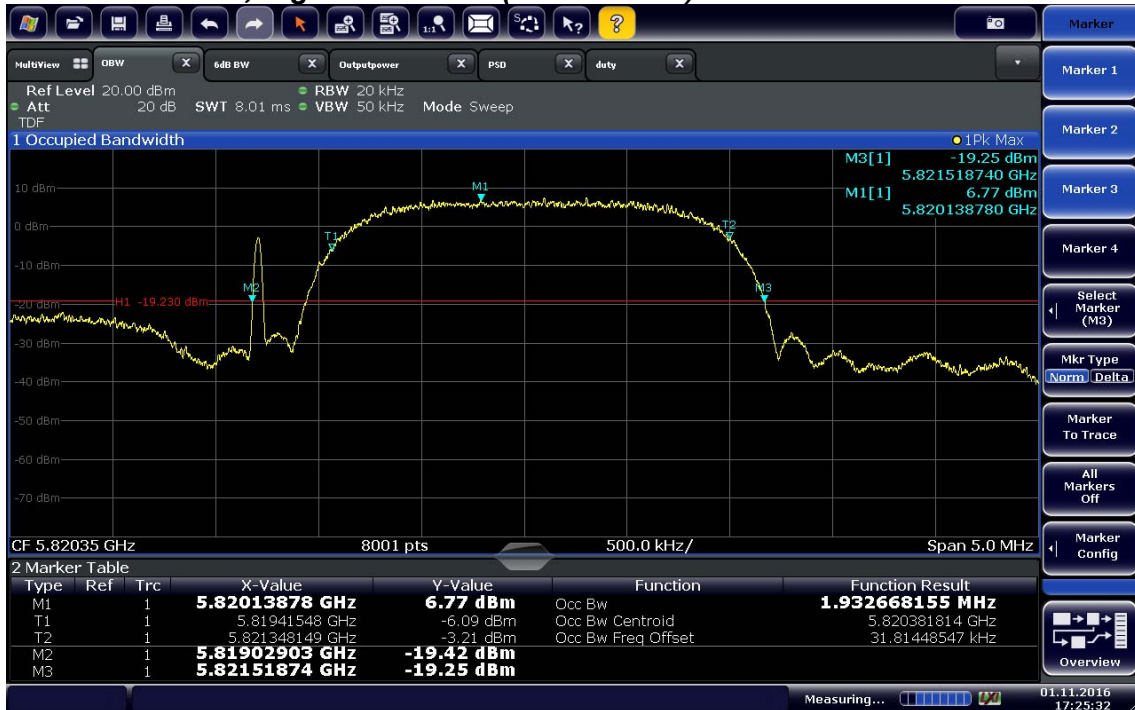

TEST DATA

8.4 6 dB Bandwidth – UNII-3 band

FCC §15.407(e), RSS-247 Issue 1 6.2

Test Mode : Set to Lowest channel, Middle channel and Highest channel

Result

Channel	Frequency(MHz)	6dB Emission Bandwidth(MHz)		Limit (kHz)
		Ant 0	Ant 1	
Low	5730.35	1.60	1.57	>500
Middle	5776.35	1.56	1.59	
High	5820.35	1.58	1.61	

PLOTS OF EMISSIONS

Ant 0

6 dB Bandwidth, Lowest Channel (5730.35 MHz)

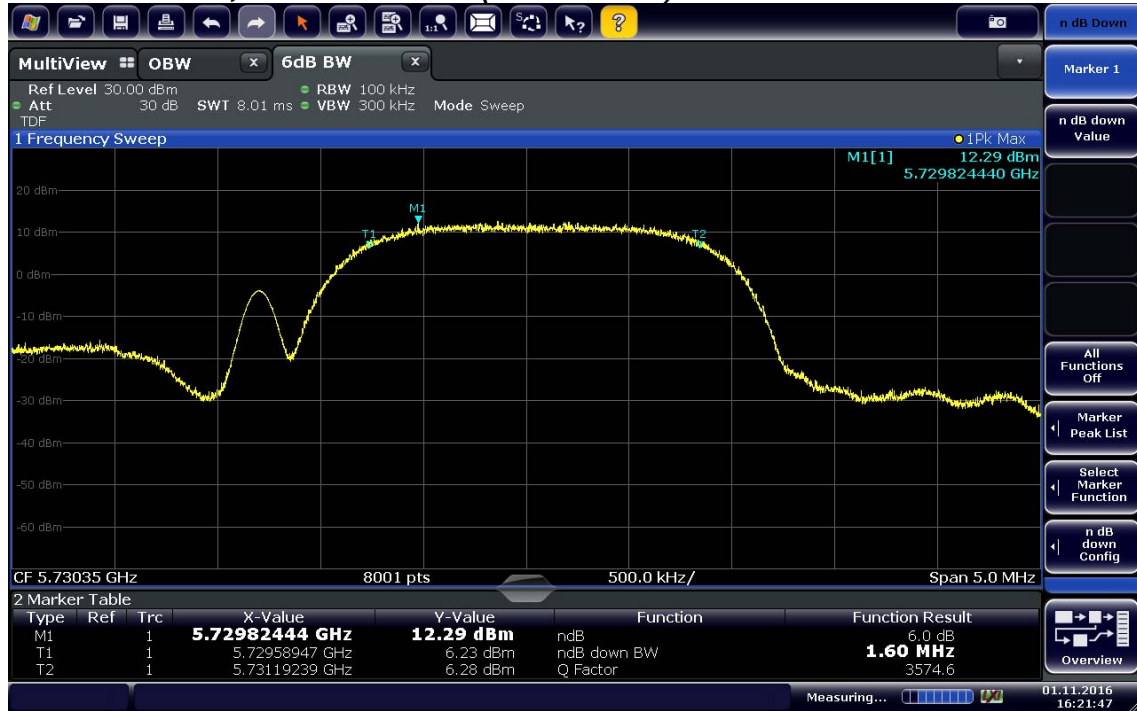

6 dB Bandwidth, Middle Channel (5776.35 MHz)



PLOTS OF EMISSIONS

6 dB Bandwidth, Highest Channel (5820.35 MHz)

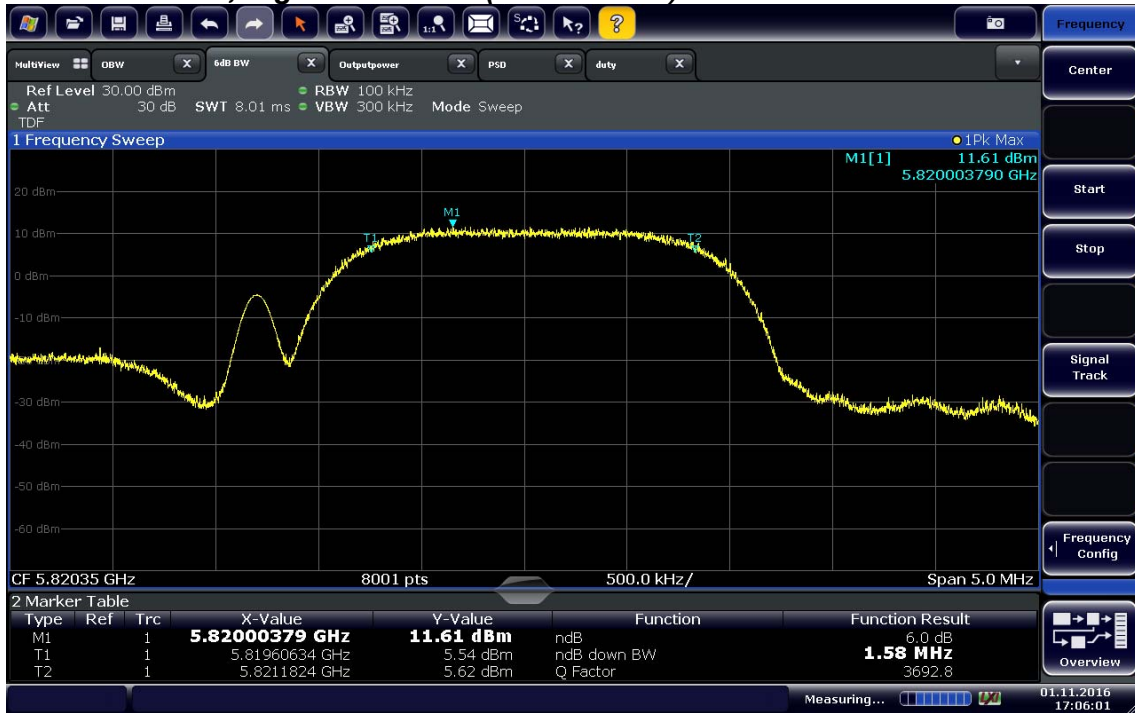

Ant 1

6 dB Bandwidth, Lowest Channel (5730.35 MHz)

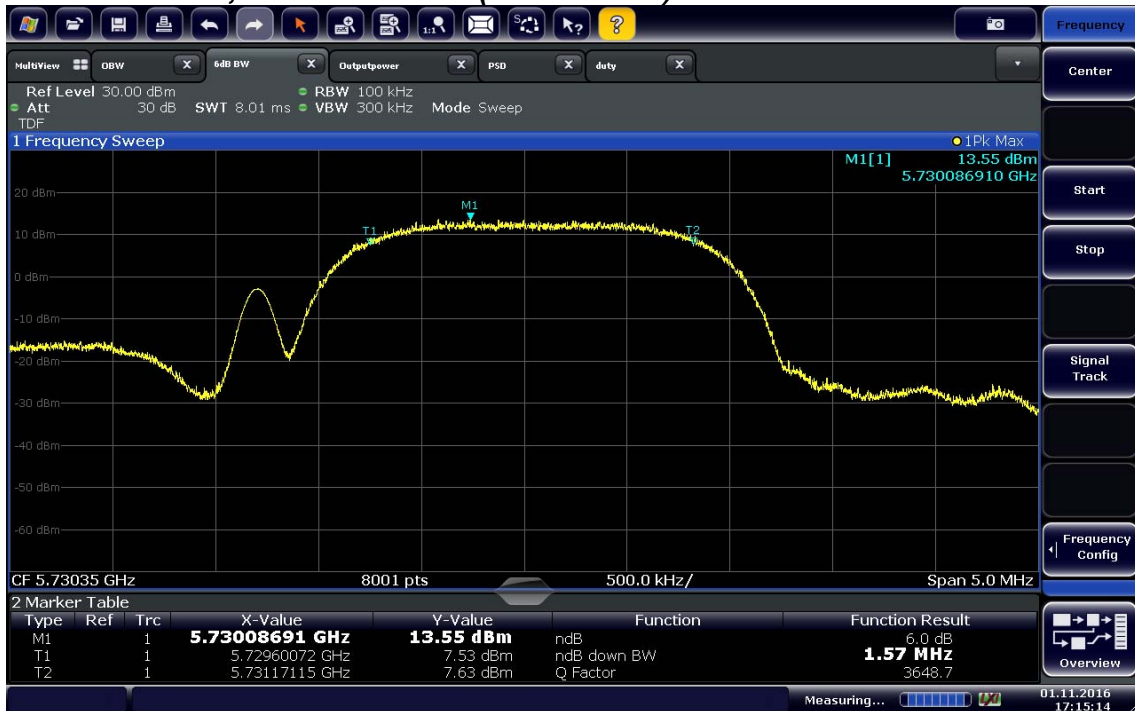

PLOTS OF EMISSIONS

6 dB Bandwidth, Middle Channel (5776.35 MHz)

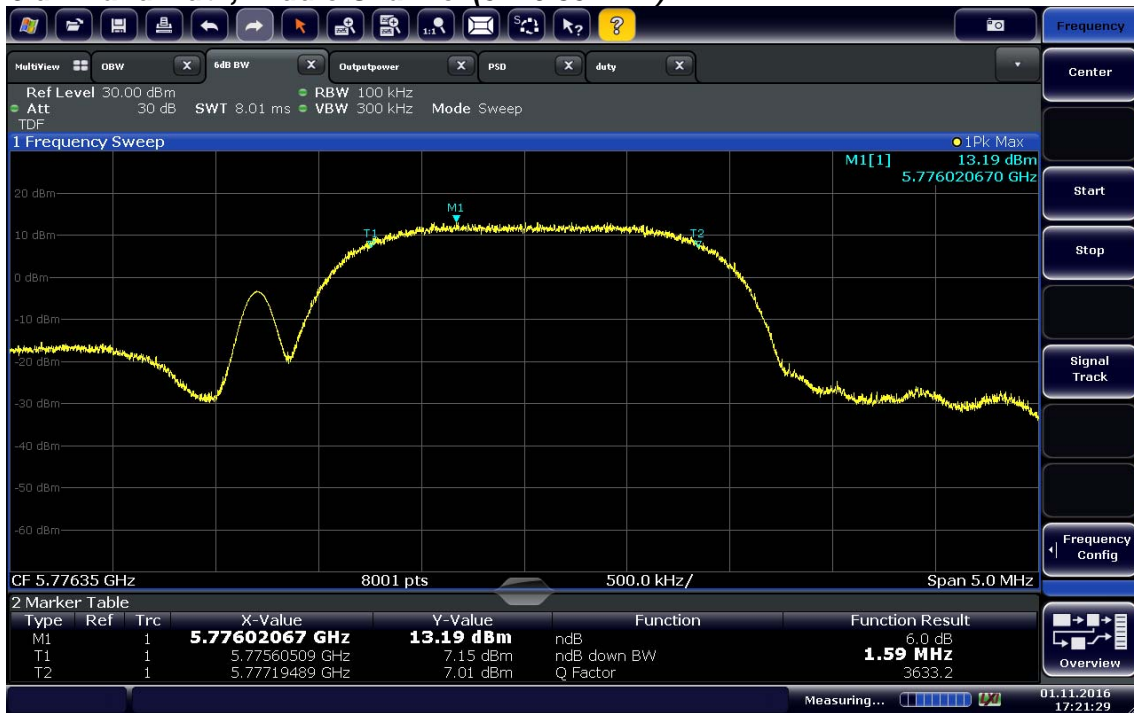

6 dB Bandwidth, Highest Channel (5820.35 MHz)

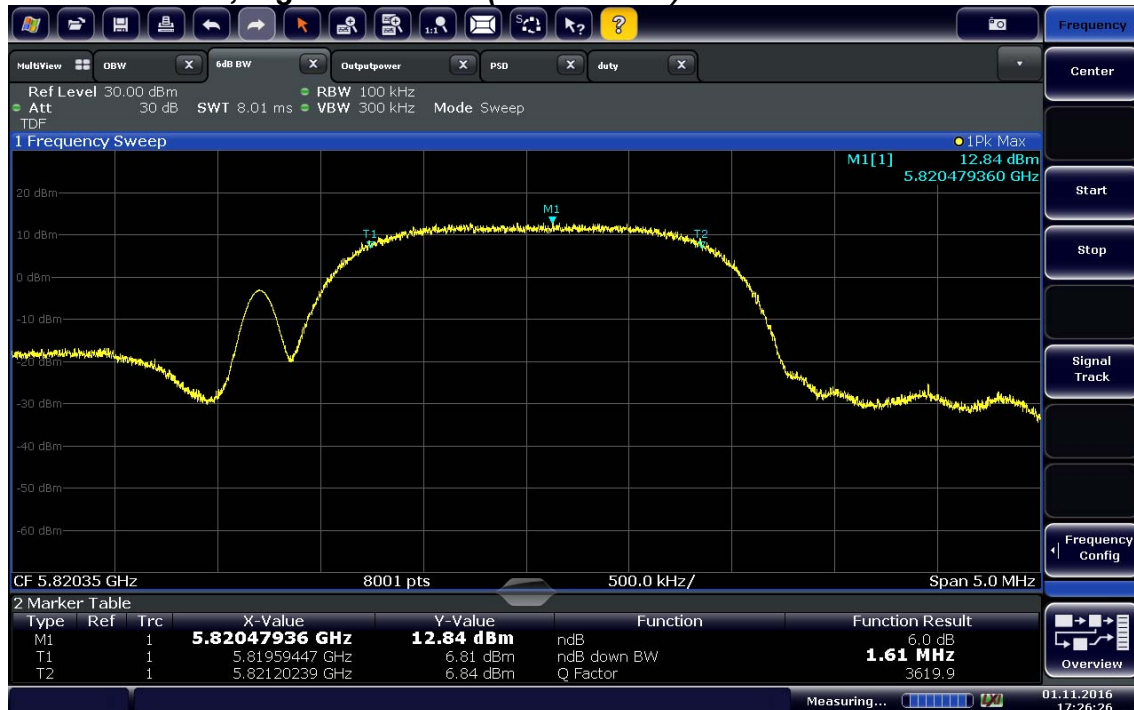

TEST DATA

8.5 Maximum Conducted Output Power (average) – UNII-3 band

FCC §15.407(a), RSS-247 Issue 1, 6.2

Test Mode : Set to Lowest channel, Middle channel and Highest channel

Result

Tx mode

Channel	Frequency (MHz)	Maximum Conducted Output Power (dBm)		FCC/IC Limit (dBm)
		Ant 0	Ant 1	
Lowest	5730.35	13.74	14.85	30.00
Middle	5776.35	13.53	14.51	30.00
Highest	5820.35	13.34	14.41	30.00

Note:

1. Maximum Conducted (average) Power was measured according to II.E.2.b) Method SA-1 in **KDB 789033**

D02 General UNII Test Procedures New Rules v01r03

2. The following equation was used for spectrum offset:

$$\text{Spectrum offset (dB)} = \text{Attenuator (dB)} + \text{Cable Loss (dB)} + \text{SMA Type Connector Loss (dB)}$$

PLOT OF TEST DATA

Ant 0

Maximum Conducted Output Power, Lowest Channel (5730.35 MHz)

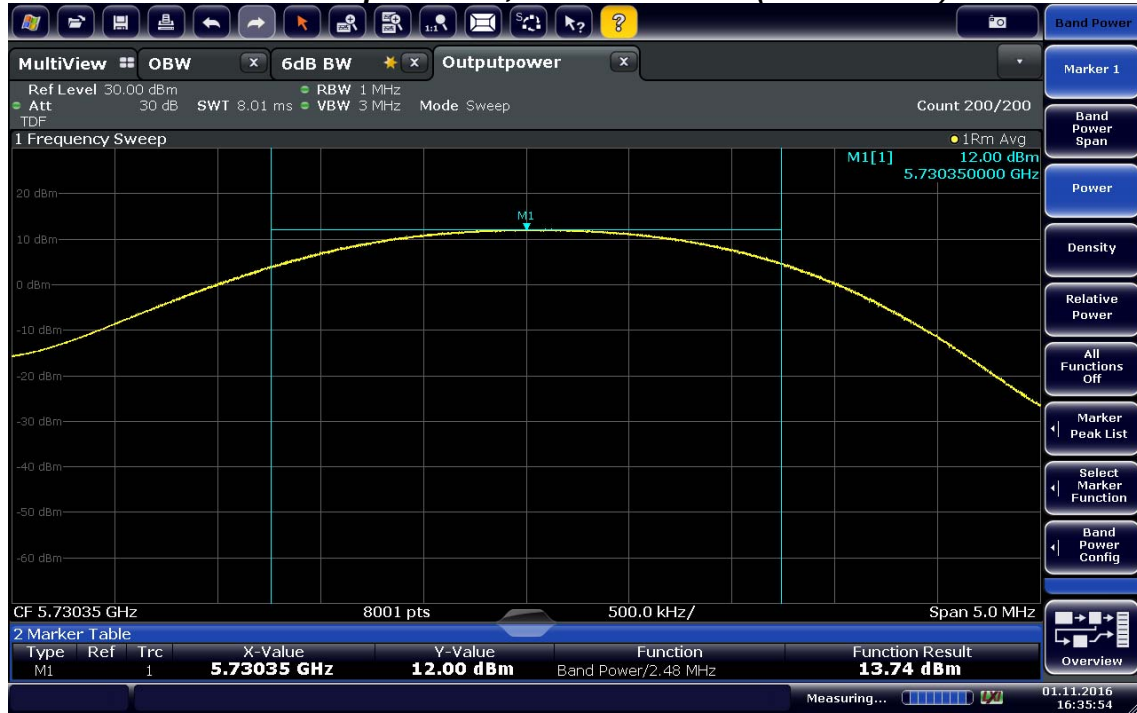

Maximum Conducted Output Power, Middle Channel (5776.35 MHz)



PLOT OF TEST DATA

Maximum Conducted Output Power, Highest Channel (5820.35 MHz)

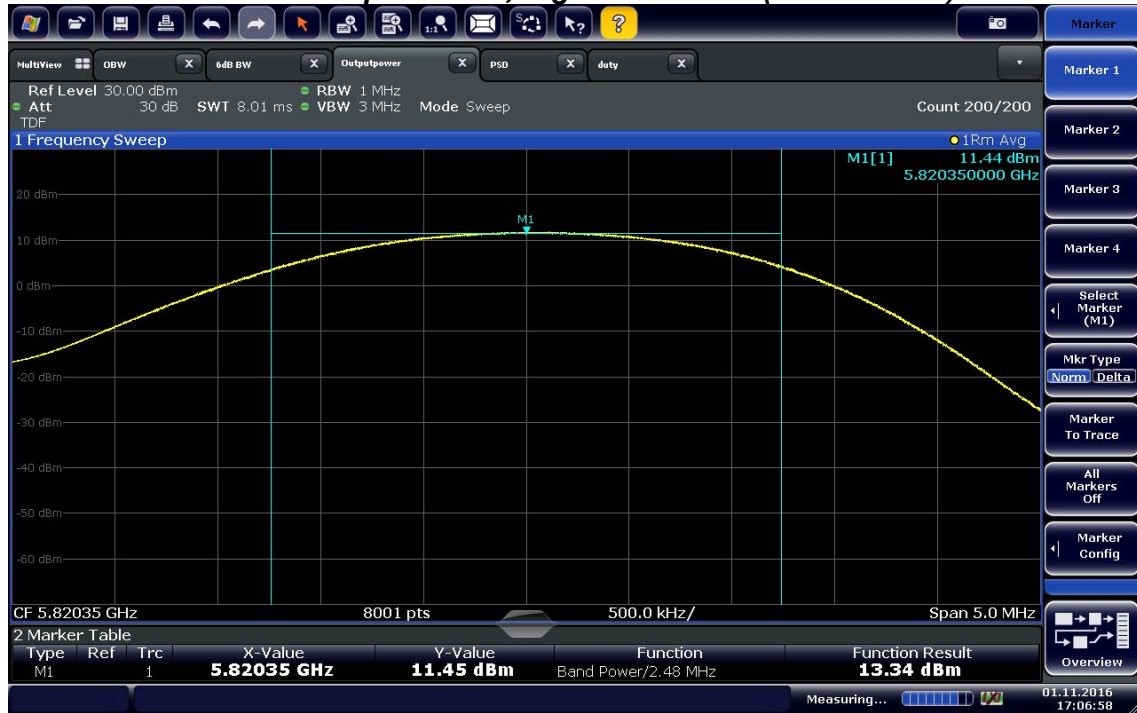

Ant 1

Maximum Conducted Output Power, Lowest Channel (5730.35 MHz)

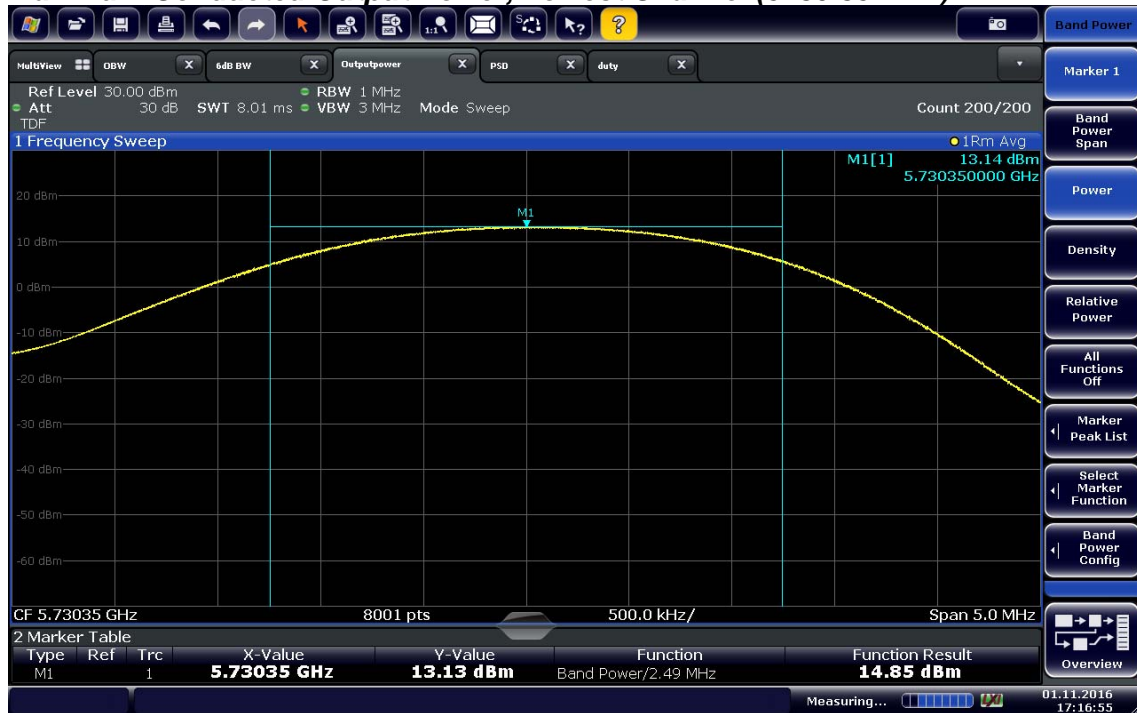

PLOT OF TEST DATA

Maximum Conducted Output Power, Middle Channel (5776.35 MHz)

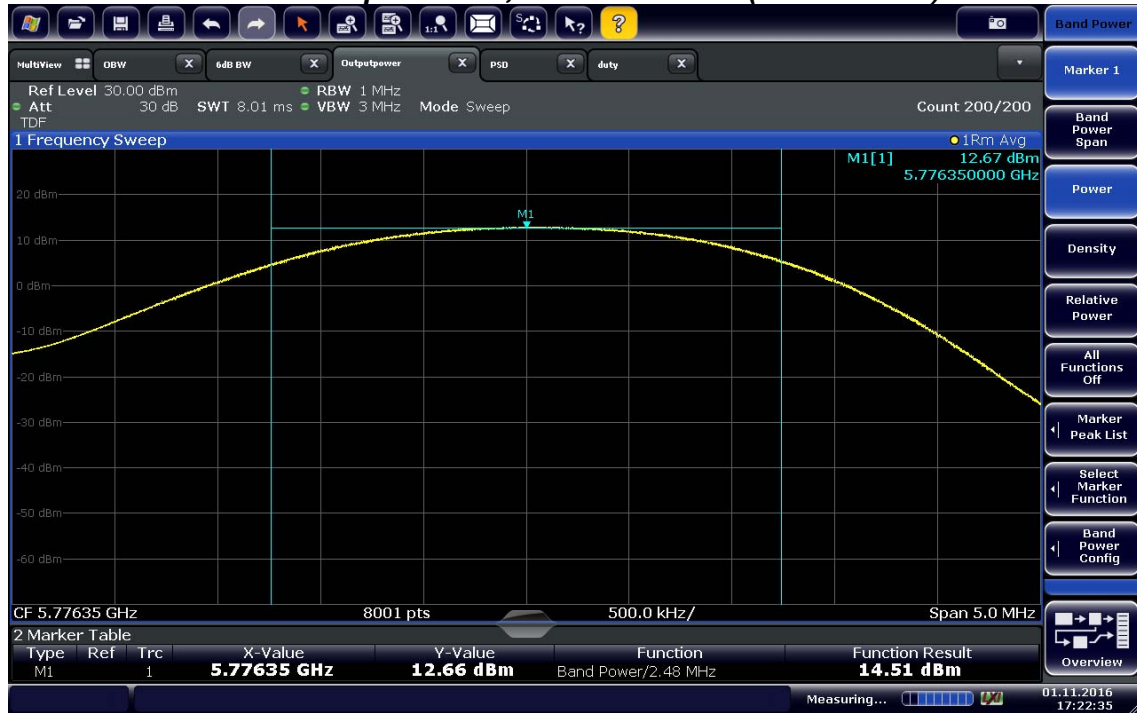

Maximum Conducted Output Power, Highest Channel (5820.35 MHz)



TEST DATA

8.6 Maximum Power Spectral Density – UNII-3 band

FCC §15.407(a), IC RSS-247 Issue 1 6.2

Test Mode : Set to Lowest channel, Middle channel and Highest channel

Result

Tx mode

Channel	Frequency (MHz)	Maximum PSD (dBm/500kHz)		FCC/IC Limit (dBm/500kHz)
		Ant 0	Ant 1	
Lowest	5730.35	9.50	10.50	30.00
Middle	5776.35	9.79	10.26	30.00
Highest	5820.35	9.22	10.44	30.00

Note:

1. Power Spectral Density(PSD) was measured by same method with conducted output power according to II.F.1 in **KDB 789033 D02 General UNII Test Procedures New Rules v01r03**
2. The following equation was used for spectrum offset:

$$\text{Spectrum offset (dB)} = \text{Attenuator (dB)} + \text{Cable Loss (dB)} + \text{SMA Type Connector Loss (dB)}$$

PLOT OF TEST DATA

Ant 0

Maximum Power Spectral Density, Lowest Channel (5730.35 MHz)



Maximum Power Spectral Density, Middle Channel (5776.35 MHz)

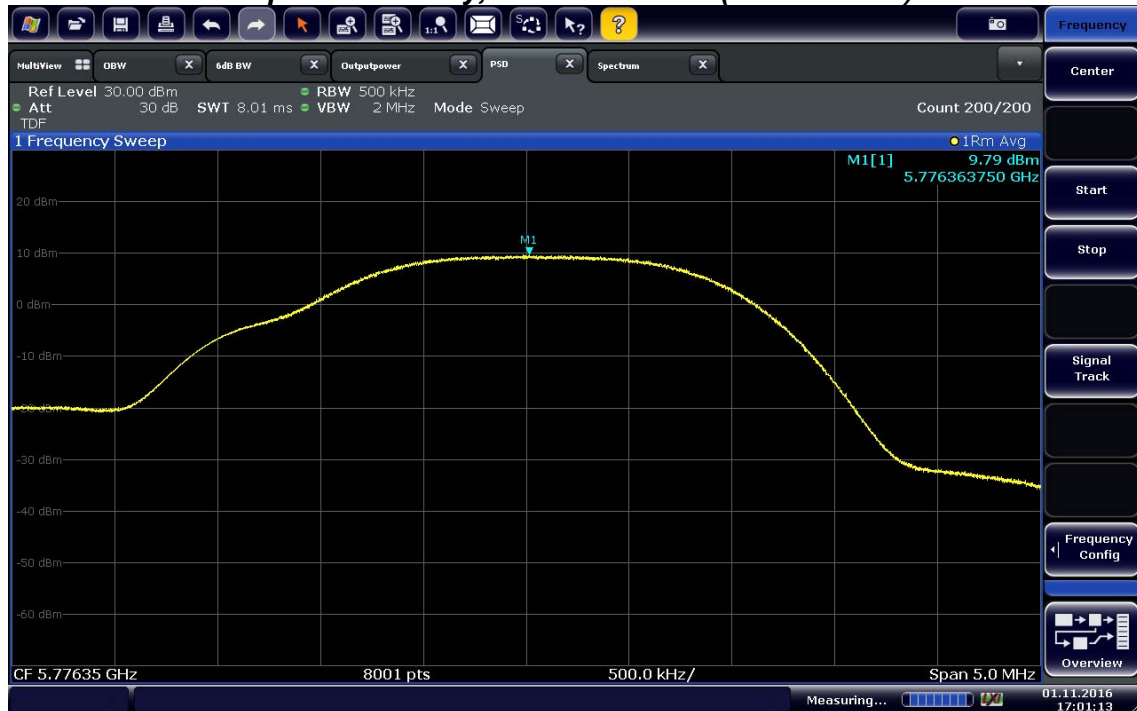

PLOT OF TEST DATA

Maximum Power Spectral Density, Highest Channel (5820.35 MHz)



Ant 1

Maximum Power Spectral Density, Lowest Channel (5730.35 MHz)



PLOT OF TEST DATA

Maximum Power Spectral Density, Middle Channel (5776.35 MHz)



Maximum Power Spectral Density, Highest Channel (5820.35 MHz)



TEST DATA

8.7 Radiated Spurious Emissions – UNII-3 band

FCC §15.407(b), RSS-247 Issue 1, 6.2

Test Mode : Set to Lowest channel, Middle channel and Highest channel

Result

Ant 1

Lowest Channel (5730.35 MHz)

Frequency (MHz)	Reading (dBμV)	Pol* (H/V)	mode	AF+CL+Amp (dB)**	Result (dBμV/m)	Limit*** (dBμV/m)	Margin (dB)
11458.22	47.3	V	peak	6.2	53.5	68.2	14.7
11458.19	40.1	V	average	6.2	46.3	54.0	7.7

Middle Channel (5776.35 MHz)

Frequency (MHz)	Reading (dBμV)	Pol* (H/V)	mode	AF+CL+Amp (dB)**	Result (dBμV/m)	Limit*** (dBμV/m)	Margin (dB)
11550.02	47.1	V	peak	6.4	53.5	68.2	14.7
11550.15	39.0	H	average	6.4	45.4	54.0	8.6

Highest Channel (5820.35 MHz)

Frequency (MHz)	Reading (dBμV)	Pol* (H/V)	mode	AF+CL+Amp (dB)**	Result (dBμV/m)	Limit*** (dBμV/m)	Margin (dB)
11638.15	48.2	V	peak	6.0	54.2	68.2	14.0
11638.18	42.5	V	average	6.0	48.5	54.0	5.5

Note:

1. *Pol. H = Horizontal V = Vertical
2. **AF + CL + Amp. = Antenna Factor + Cable Loss + Amplifier.
3. At frequencies above 1 GHz, peak emissions were measured using RBW = 1 MHz, VBW = 3 MHz, Detector = Peak.
4. EUT has 100% duty cycle. As the EUT was configured to transmit with duty cycles ≥ 98 percent, at frequencies above 1 GHz, average emission levels were measured using the "Method VB" by setting the analyzer RBW = 1 MHz, VBW = 1 kHz ($VBW \leq RBW/100$), Detector = Peak.
5. The spectrum is measured from 9 kHz to 10th harmonic and the worst-case emissions are reported.
No significant emissions were found beyond the Second harmonic for this device.
6. ***For outside of the restricted band, the peak limit is applied according to Part 15.407(b)(4)(i), RSS-247 6.2.4 (2).
For FCC limit, EIPR[dBm] is specified in 15.407(b)(4)(i) as -27dBm/MHz at 75MHz or more above or below the bandedge.
Peak limit is 68.2 dB μ V/m. ($E[\text{dB}\mu\text{V}/\text{m}] = \text{EIPR}[\text{dBm}/\text{MHz}] + 95.2 = 68.2 \text{ dB}\mu\text{V}/\text{m}$, for $\text{EIPR}[\text{dBm}/\text{MHz}] = -27\text{dBm}$.)
The limit of bandedge to 75MHz above or below bandedge is specified in clause 8.8 note 8 in this report.
For IC limit, All emissions within the frequency range from the band edge to 10 MHz above or below the band edge shall not exceed an e.i.r.p. of -17 dBm/MHz; for frequencies 10 MHz or greater above or below the band edge, emissions shall not exceed an e.i.r.p. of -27 dBm/MHz.
Peak limit is 78.2 dB μ V/m. ($E[\text{dB}\mu\text{V}/\text{m}] = \text{EIPR}[\text{dBm}/\text{MHz}] + 95.2 = 78.2 \text{ dB}\mu\text{V}/\text{m}$, for $\text{EIPR}[\text{dBm}/\text{MHz}] = -17\text{dBm}/\text{MHz}$.)
Peak limit is 68.2 dB μ V/m. ($E[\text{dB}\mu\text{V}/\text{m}] = \text{EIPR}[\text{dBm}/\text{MHz}] + 95.2 = 68.2 \text{ dB}\mu\text{V}/\text{m}$, for $\text{EIPR}[\text{dBm}/\text{MHz}] = -27\text{dBm}$.)
7. For restricted band, the peak limit is 68.2 dB μ V/m, the average limit is 54 dB μ V/m per FCC §15.209 and RSS-GEN Issue4 8.9
8. Highest channel(5820.35MHz) was the worst channel with respect to 2nd harmonic.
9. The radiated emissions testing were made by rotating EUT through three orthogonal axes and rotating the receive antenna with horizontal, Vertical polarization. The worst data was recorded.
10. At frequencies above 1 GHz, EUT was placed at a height of 1.5m above the floor on a support according to ANSI 63.10-2013.

PLOTS OF EMISSIONS

Worst Case

Ant 1

Highest channel (5820.35 MHz) : 1 GHz to 8 GHz

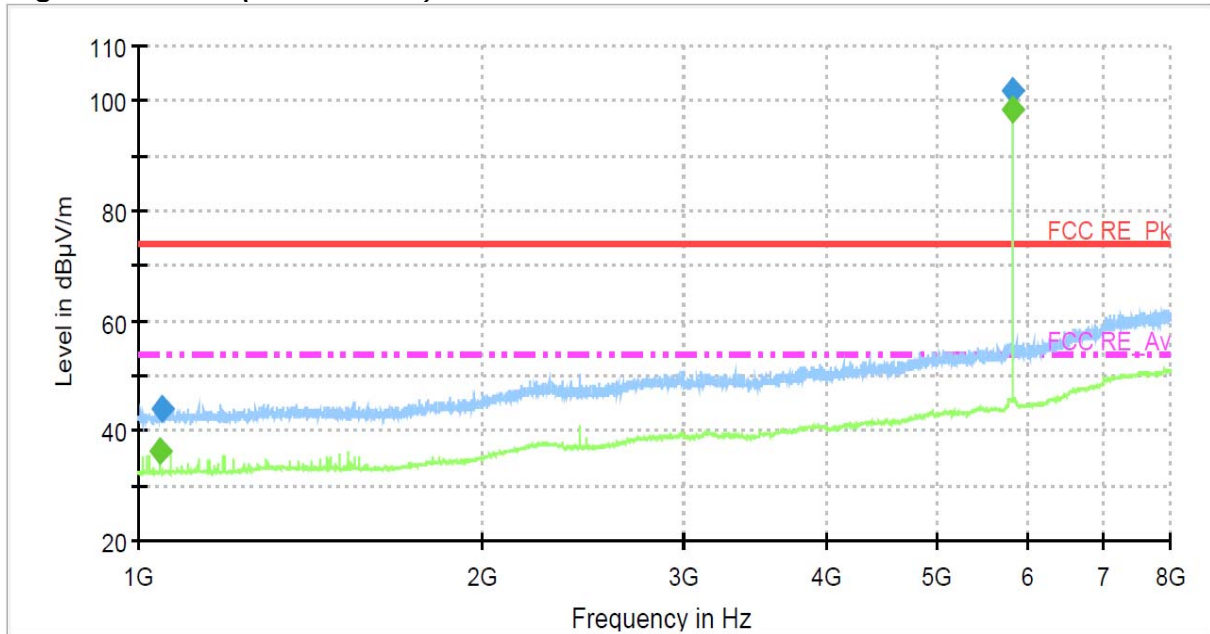

Highest channel (5820.35 MHz) : 8 GHz to 18 GHz

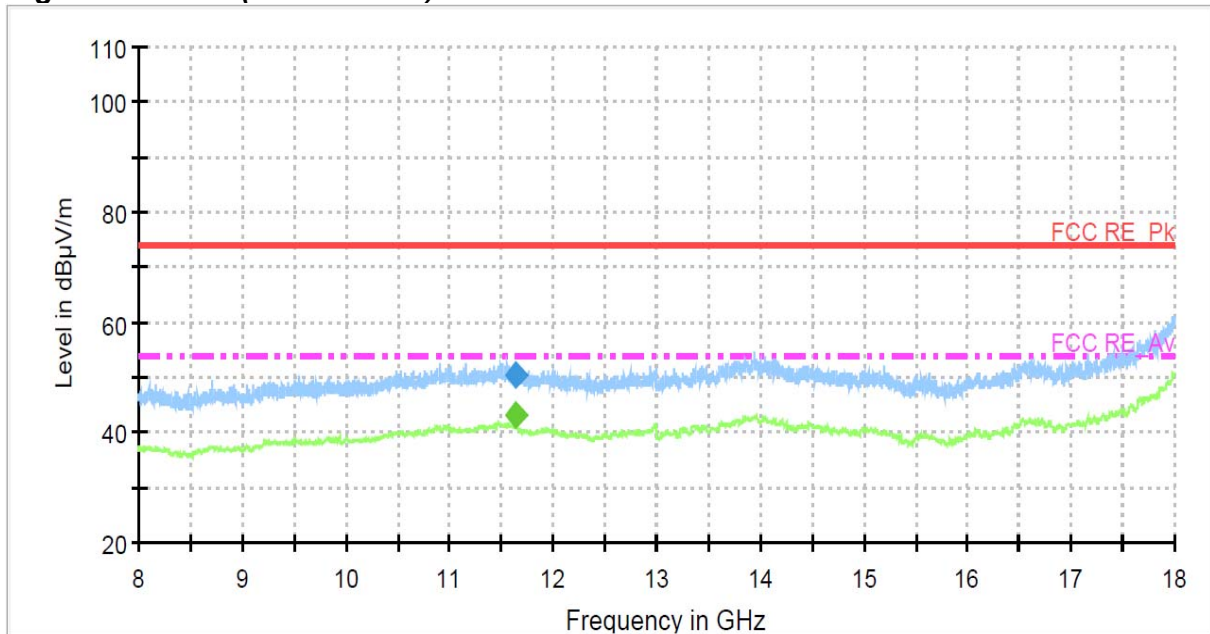

PLOTS OF EMISSIONS

Highest channel (5820.35 MHz) : 18 GHz to 26.5 GHz

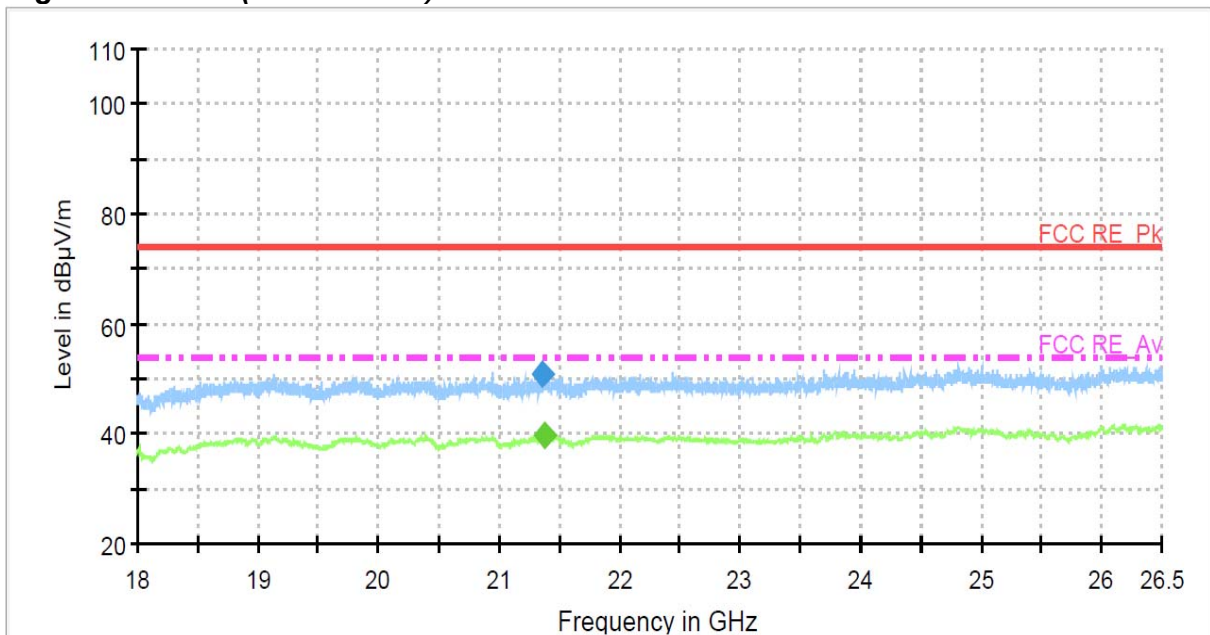

Highest channel (5820.35 MHz) : 26.5 GHz to 40 GHz

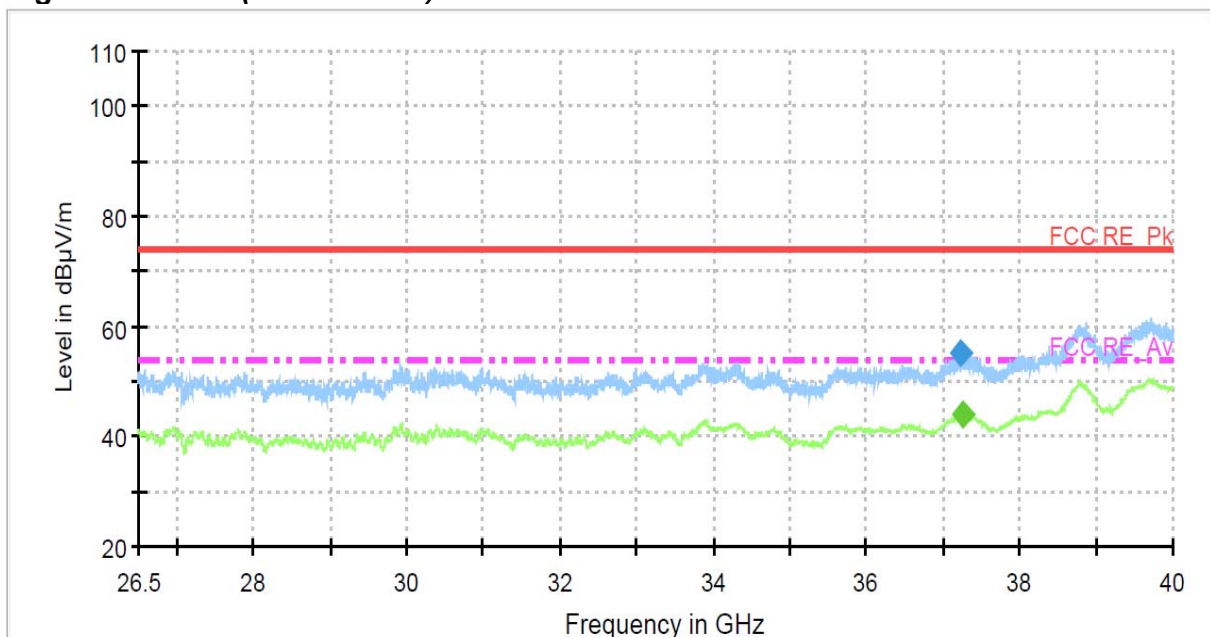

TEST DATA

8.8 Radiated Band Edge – UNII-3 band

FCC §15.407(b), RSS-247 Issue 1, 6.2

Test Mode : Set to Lowest channel and Highest channel

Result

Ant 1

Lowest and Highest Channels

Frequency (MHz)	Reading (dBμV)	Pol* (H/V)	mode	AF+CL+ Amp (dB)**	Result (dBμV/m)	Limit***		Margin	
						FCC (dBμV/m)	IC (dBμV/m)	FCC (dB)	IC (dB)
5725.00	48.30	H	peak	11.90	60.20	122.2	78.2	62.00	18.00
5850.00	41.10	V	peak	12.50	53.60	122.2	78.2	68.60	24.60

Note:

- *Pol. H = Horizontal V = Vertical
- **AF + CL + Amp. = Antenna Factor + Cable Loss + Amplifier.
- At frequencies above 1 GHz, peak emissions were measured using RBW = 1 MHz, VBW = 3 MHz, Detector = Peak.
- EUT has 100% duty cycle. As the EUT was configured to transmit with duty cycles ≥ 98 percent, at frequencies above 1 GHz, average emission levels were measured using the “Method VB” by setting the analyzer RBW = 1 MHz, VBW = 1 kHz (VBW ≤ RBW/100), Detector = Peak.
- The radiated emissions testing were made by rotating EUT through three orthogonal axes and rotating the receive antenna with horizontal, Vertical polarization. The worst data was recorded.
- At frequencies above 1 GHz, EUT was placed at a height of 1.5m above the floor on a support according to ANSI 63.10-2013.

7. For restricted band, the peak limit is 68 dB μ V/m, the average limit is 54 dB μ V/m per FCC §15.209 and RSS-GEN Issue4 8.9
8. ***For outside of the restricted band, the peak limit is applied according to Part 15.407(b)(4)(i), RSS-247 6.2.4 (2).

For FCC limit, the limit of bandedge to 75MHz above or below bandedge is specified in 15.407(b)(4)(i) as below.

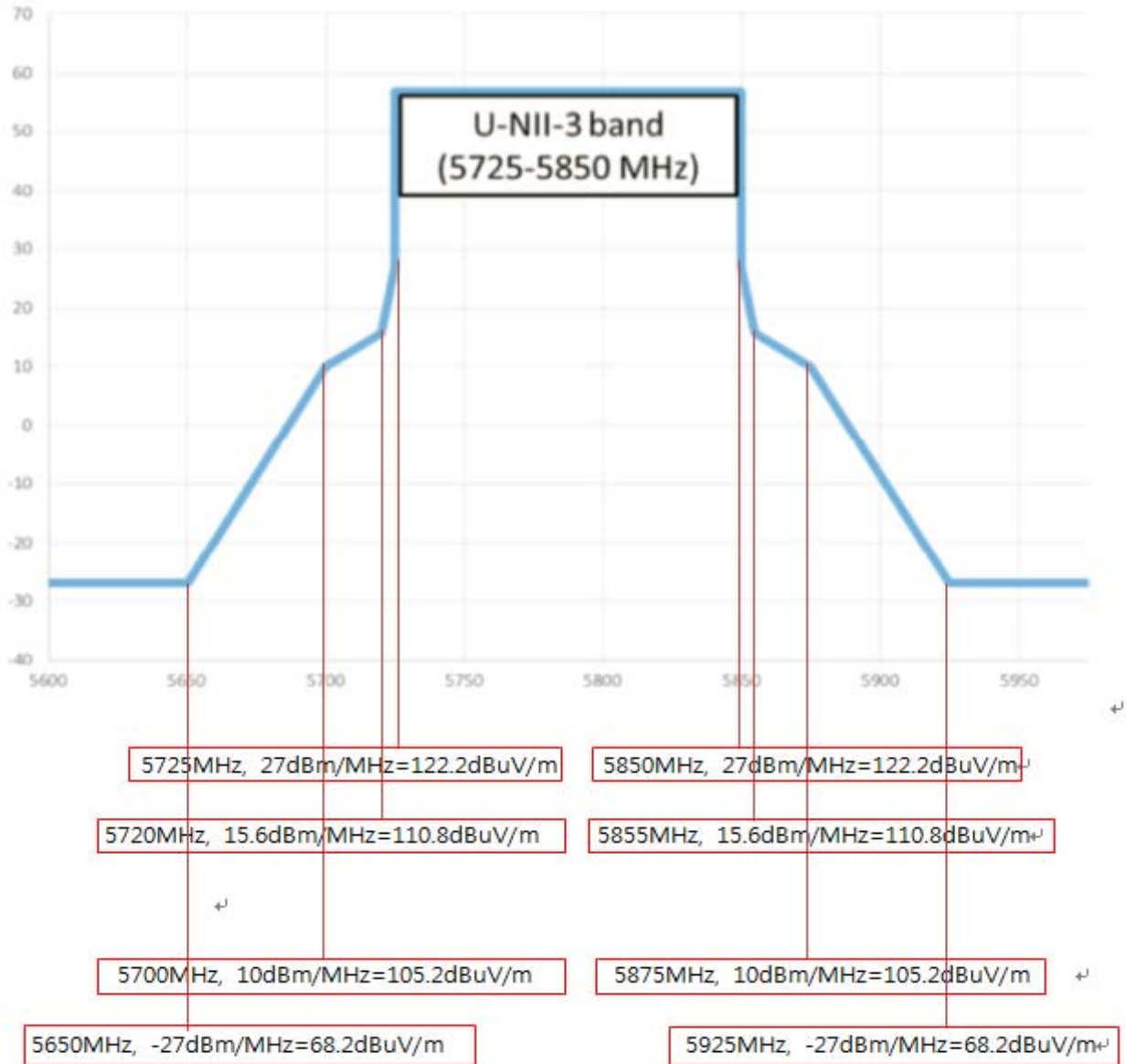

For IC limit, All emissions within the frequency range from the band edge to 10 MHz above or below the band edge shall not exceed an e.i.r.p. of -17 dBm/MHz; for frequencies 10 MHz or greater above or below the band edge, emissions shall not exceed an e.i.r.p. of -27 dBm/MHz.

Peak limit is 78.2 dB μ V/m. ($E[\text{dB}\mu\text{V}/\text{m}] = \text{EIRP}[\text{dBm}/\text{MHz}] + 95.2 = 78.2 \text{ dB}\mu\text{V}/\text{m}$, for $\text{EIRP}[\text{dBm}/\text{MHz}] = -17\text{dBm}/\text{MHz}$)

Peak limit is 68.2 dB μ V/m. ($E[\text{dB}\mu\text{V}/\text{m}] = \text{EIRP}[\text{dBm}/\text{MHz}] + 95.2 = 68.2 \text{ dB}\mu\text{V}/\text{m}$, for $\text{EIRP}[\text{dBm}/\text{MHz}] = -27\text{dBm}/\text{MHz}$)

PLOT OF TEST DATA

Worst Case

Ant 1

Lowest Channel (5730.35 MHz)_PK

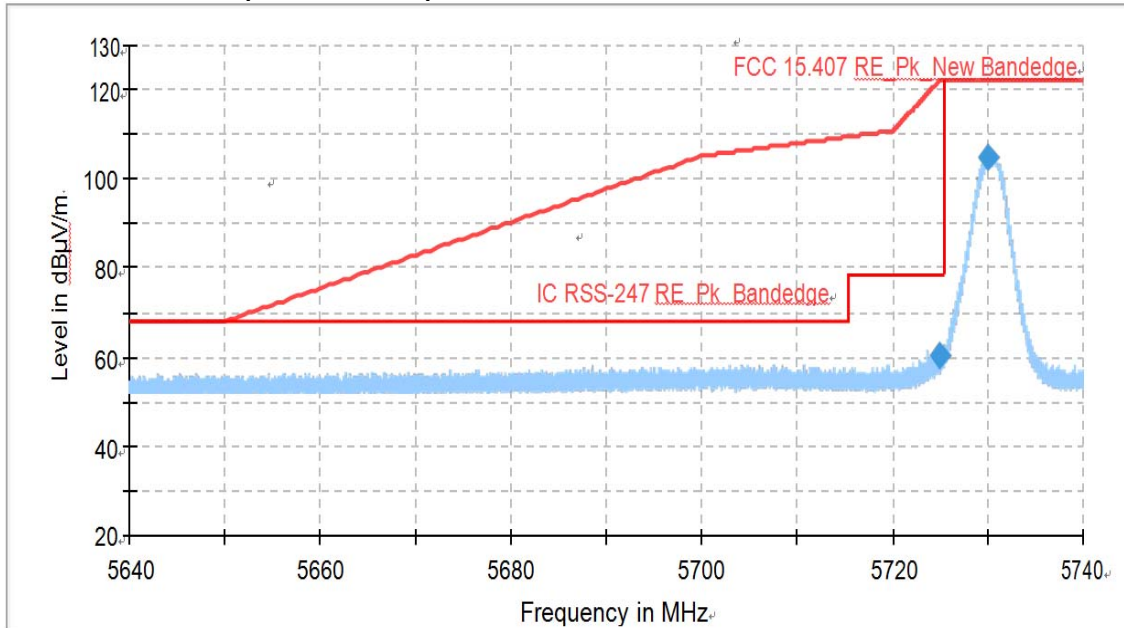

Highest Channel (5820.35 MHz)_PK

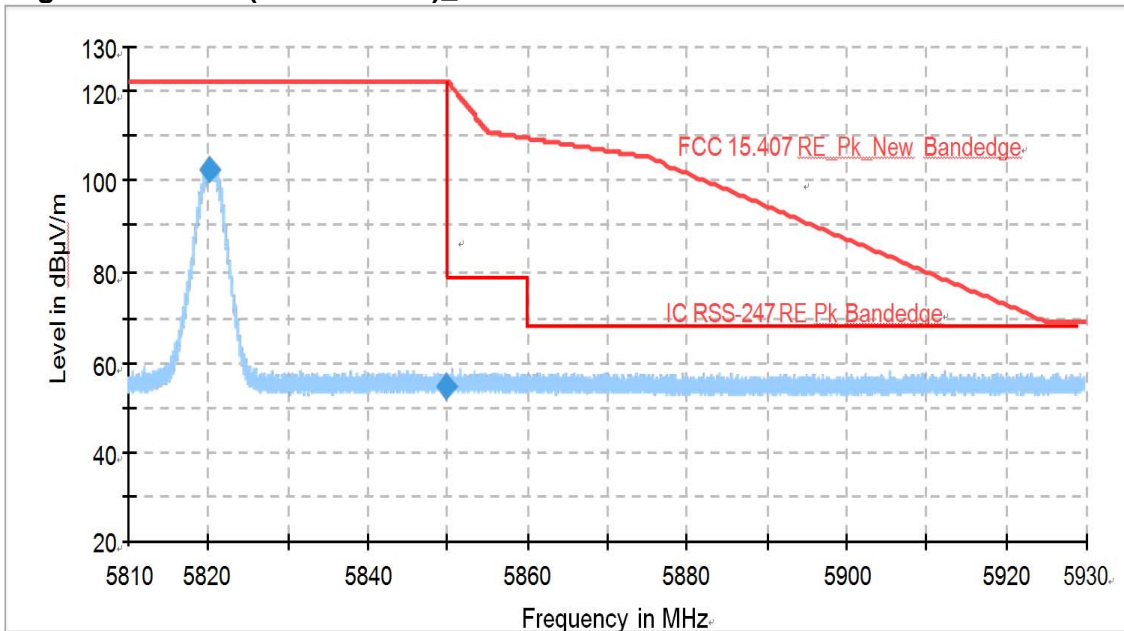

9. TEST EQUIPMENT

No.	Instrument	Manufacturer	Model	Serial No.	Calibration Date	Calibration Interval
1	*Test Receiver	R & S	ESU 40	100202	Apr. 04 2016	1 year
2	*Test Receiver	R & S	ESCS30	100302	Oct. 07 2016	1 year
3	*Attenuator	PASTERNAK	PE7395-10	1441	Jan. 19 2016	1 year
4	*Attenuator	FAIRVIEW	SA3N5W-06	N/A	Apr. 04 2016	1 year
5	*Attenuator	FAIRVIEW	SA3N5W-10	N/A	July. 14 2016	1 year
6	Attenuator	WEINSCHL	56-10	58765	Oct. 09 2016	1 year
7	*Amplifier	R & S	SCU 01	10030	Apr. 04 2016	1 year
8	*Amplifier	R & S	SCU18	10065	Apr. 04 2016	1 year
9	*Amplifier	R & S	SCU26	10011	Jul. 15 2016	1 year
10	*Amplifier	R & S	SCU40	10008	Jul. 15 2016	1 year
11	*Pre Amplifier	HP	8449B	3008A00107	Jan. 07 2016	1 year
12	*Spectrum Analyzer	R & S	FSW43	100732	Apr. 05 2016	1 year
13	Spectrum Analyzer	Agilent	N9020A	MY51110087	Oct. 07 2016	1 year
14	*Spectrum Analyzer	R&S	FSP40	100361	Jul. 15 2016	1 year
15	*Loop Antenna	R & S	HFH2-Z2	100279	Feb. 22 2016	2 year
16	*Horn Antenna	SCHWARZBECK	BBHA9120D	9120D-474	Sep. 30 2016	2 year
17	*Horn Antenna	Q-par Angus	QSH20S20	8179	Apr. 30 2015	2 year
18	*Horn Antenna	Q-par Angus	QSH22K20	8180	Apr. 30 2015	2 year
19	*Trilog-Broadband Antenna	SCHWARZBECK	VULB 9168	9163-257	Apr. 15 2016	2 year
20	*LISN	R & S	ESH3-Z5	833874/006	Oct. 06 2016	1 year
21	*Controller	INNCO	CO2000-G	CO2000/562/23890210/L	N/A	N/A
22	*Turn Table	INNCO	DT3000-3T	N/A	N/A	N/A
23	*Antenna Mast	INNCO	MA4000-EP	N/A	N/A	N/A
24	*Open Switch And Control Unit	R & S	OSP-120	100015	N/A	N/A
25	*Anechoic Chamber	Seo-Young EMC	N/A	N/A	N/A	N/A
26	*Position Controller	INNCO	CO2000	12480406/L	N/A	N/A
27	*Turn Table	INNCO	DS1200S	N/A	N/A	N/A
28	*Antenna Mast	INNCO	MA4000	N/A	N/A	N/A
29	*Anechoic Chamber	Seo-Young EMC	N/A	N/A	N/A	N/A
30	Shielded Room	Seo-Young EMC	N/A	N/A	N/A	N/A
31	*Open Switch And Control Unit	R & S	OSP-120	100081	N/A	N/A

*) Test equipment used during the test

10. ACCURACY OF MEASUREMENT

The Measurement Uncertainties stated were calculated in accordance with the requirements of measurement uncertainty contained in CISPR 16-4-2 with the confidence level of 95%

1. Conducted Uncertainty Calculation

Source of Uncertainty	X_i	Uncertainty of X_i		Coverage factor k	$u(X_i)$ (dB)	C_i	$C_i u(X_i)$ (dB)
		Value (dB)	Probability Distribution				
Receiver reading	RI	± 0.1	normal 1	1.000	0.1	1	0.1
Attenuation AMN-Receiver	LC	± 0.08	normal 2	2.000	0.04	1	0.04
AMN Voltage division factor	LAMN	± 0.8	normal 2	2.000	0.4	1	0.4
Sine wave voltage	dVSW	± 2.00	normal 2	2.000	1.00	1	1.00
Pulse amplitude response	dVPA	± 1.50	rectangular	1.732	0.87	1	0.87
Pulse repetition rate response	dVPR	± 1.50	rectangular	1.732	0.87	1	0.87
Noise floor proximity	dVNF	± 0.00	-	-	0.00	1	0.00
AMN Impedance	dZ	± 1.80	triangular	2.449	0.73	1	0.73
Ⓐ Mismatch	M	+ 0.70	U-Shaped	1.414	0.49	1	0.49
Ⓑ Mismatch	M	- 0.80	U-Shaped	1.414	- 0.56	1	- 0.56
Measurement System Repeatability	RS	0.05	normal 1	1.000	0.05	1	0.05
Remark	Ⓐ: AMN-Receiver Mismatch : + Ⓑ: AMN-Receiver Mismatch : -						
Combined Standard Uncertainty	Normal			± 1.88			
Expanded Uncertainty U	Normal ($k = 2$)			± 3.76			

2. Radiation Uncertainty Calculation

Source of Uncertainty	X_i	Uncertainty of X_i		Coverage factor k	$u(X_i)$ (dB)	C_i	$C_i u(X_i)$ (dB)
		Value (dB)	Probability Distribution				
Measurement System Repeatability	RI	0.34	normal 1	1.00	0.34	1	0.34
Receiver reading	dVsw	± 0.02	normal 2	2.00	0.01	1	0.01
Sine wave voltage	dVpa	± 0.17	normal 2	2.00	0.09	1	0.09
Pulse amplitude response	dVpr	± 0.92	normal 2	2.00	0.46	1	0.46
Pulse repetition rate response	dVnf	± 0.35	normal 2	2.00	0.18	1	0.18
Noise floor proximity	AF	± 0.50	normal 2	2.00	0.25	1	0.25
Antenna Factor Calibration	CL	± 2.00	rectangular	$\sqrt{3}$	1.15	1	1.15
Cable Loss	AD	± 1.00	normal 2	2.00	0.50	1	0.50
Antenna Directivity	AH	± 0.00	rectangular	$\sqrt{3}$	0.00	1	0.00
Antenna Factor Height Dependence	AP	± 2.00	rectangular	$\sqrt{3}$	1.15	1	1.15
Antenna Phase Centre Variation	AI	± 0.20	rectangular	$\sqrt{3}$	0.12	1	0.12
Antenna Factor Frequency Interpolation	SI	± 0.25	rectangular	$\sqrt{3}$	0.14	1	0.14
Site Imperfections	DV	± 4.00	triangular	$\sqrt{6}$	1.63	1	1.63
Measurement Distance Variation	Dbal	± 0.60	rectangular	$\sqrt{3}$	0.35	1	0.35
Antenna Balance	DCross	± 0.90	rectangular	$\sqrt{3}$	0.52	1	0.52
Cross Polarisation	M	± 0.00	rectangular	$\sqrt{3}$	0.00	1	0.18
Mismatch	M	+ 0.98 - 1.11	U-Shaped	$\sqrt{2}$	0.74	1	0.74
EUT Volume Diameter	M	0.33	normal 1	1.00	0.33	1	0.11
Remark							
Combined Standard Uncertainty	Normal						
Expanded Uncertainty U	Normal ($k = 2$)						