

User Manual

1. General Specification

The WSA520S is optimized for 5GHz wireless audio transceiver module that optimized for building point to multi-point digital wireless audio solutions (such as wireless subwoofers and wireless rear speakers and in-home theater system). This wireless audio module provides a highly-integrated and flexible wireless audio solution based on the SKY76303 SoC.

The module contains all the necessary radio transceiver and digital baseband circuitry to form a complete digital wireless node without the need for external processing. The module can operate in both the lower and upper bands of the 5 GHz spectrum, enabling worldwide coverage.

The module contains all the necessary power management and analog circuitry needed to operate the chip. The chip is powered from a +5 V supply input (powering the internal +3.3 V output LDO)

The RF section and wireless protocol of this module has been certified globally, including North America, Europe, China, Japan and Korea.

Features:

- Device Type : Wireless Audio module
- Wireless : SRD (Short-Range-Device) using 5GHz ISM band
- Product Size
 - Module Size (mm): 30.0 (W) X 40.4 (L) X 3.2 (H)
 - PCB size (mm): 30.3 (W) X 40.4 (L) x 1.2 (H)
 - Shield can (mm): 20.5 (W) X 22.5 (L) X 2.0(H)
 - Antenna Type : PCB Printed Antenna
- Complete I2S to I2S audio communication system
 - 24bit I2S Audio interface and 120dB SNR Over-The-Air Link
- Frequency range : 5725-5.875 GHz
- Low, fixed latency (typically less than 20ms)
- 3Mbps or 6Mbps OTA data rate
- Multiple OTA audio configurations
- Forward error correction coding, error detection, and audio-specific error concealment
- Auto-search/sync and dynamic channel selection
- Capability to detect and avoid wideband interferences such as 5GHz band WLAN
- Sample rate converter: Support for 32 - 96kHz input sample rates
- Dual printed PCB diversity antennas for multipath and fading mitigations
- Control interfaces: I2C
- Multiple GPIOs
- Dual printed PCB diversity antennas for multipath and fading mitigation

Applications:

- Soundbar with Wireless Subwoofer or/and Wireless Surround Speakers
- Home theater Wireless speaker

2. Module Identification



The hardware for the audio input (transmit) and audio output (receive) versions of the module is identical and only the firmware loaded onto the module determines its function. The distinction according to the module's function is to be identified by the module's label color and code name.

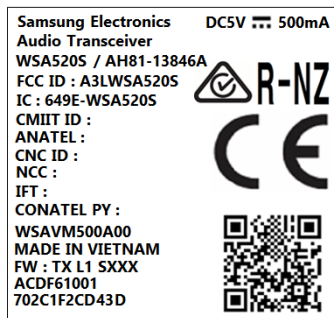

TX

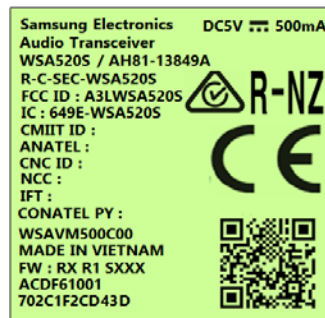

RX-Woofer

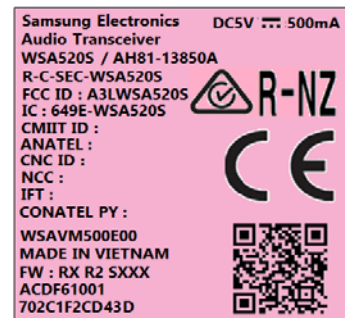

RX-Rear

The module's label displays the following information:

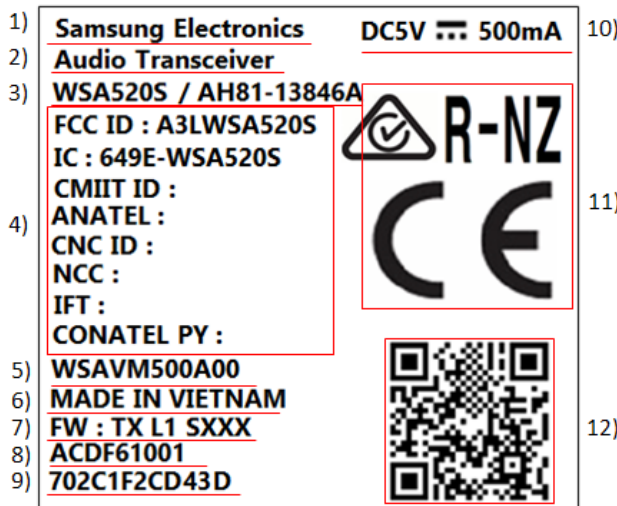

No.	Information Description
1	Product Property
2	Product Application
3	Model / Code Name
4	Certification ID
5	Manufacturer Part Name
6	Manufacturing Country
7	Firmware Version
8	Product Lot Number
9	Product Serial Number
10	Input Rating Voltage/Current
11	Certification Mark : CE, RCM
12	QR (S/N, Product Code)

3. Module Connection

The WSA520S has a 24pin FFC connector, and the connection with the external device should use FFC cable.

- Pin assignment (24pin I/O connector)

No	Pin Name	I/O	WSA520S-TX	WSA520S-RX
1	VDD_5V	PWR	+5V Supply Input	+5V Supply Input
2	VDD_5V	PWR	+5V Supply Input	+5V Supply Input
3	GPIO5/I2CS_SCL	I/O	I2C slave serial data	PWM_RST
4	GPIO4/I2CS_SDA	I/O	I2C slave serial clock	E_MUTE
5	GPIO19	I/O		P_ON
6	RESET	I/O	RESET	MICOM_RST
7	GPIO20	I/O		MUX_Control
8	GPIO21	I/O	INT	INT
9	GPIO17/I2CM_SCL	I/O		I2C master serial data
10	GPIO16/I2CM_SDA	I/O		I2C master serial clock
11	MCLK	I/O	Master clock	Master clock
12	GND	GND	GND	GND
13	BCK	I/O	bit clock	bit clock
14	LRCK	I/O	L/R clock	L/R clock
15	GPIO25	I/O		
16	I2S_DAT0	I/O	I2S port0 audio data	I2S port0 audio data
17	GPIO26	I/O	SPK_SEL	SPK_SEL
18	I2S_DAT1	I/O	I2S port1 audio data	I2S port1 audio data
19	GPIO15	I/O		DSP_RST
20	GPIO18	I/O		ID_SET
21	GPIO2	I/O		RED_LED
22	GPIO3	I/O		Blue LED
23	GPIO24	I/O		AMP_Shutdown
24	GND	GND	Ground	Ground

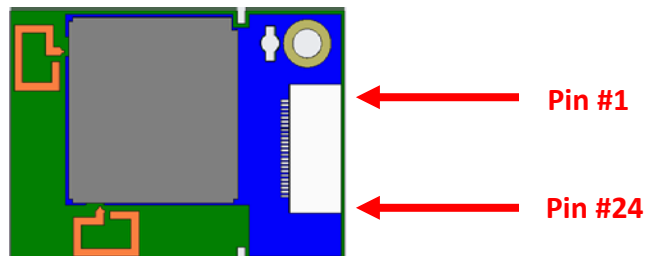

4. Applications

The WSA520S module is available in two variations; digital input transmitter or digital output receiver.

There are two available I2S digital audio data inputs/outputs, each of these can be configured to operate as either a master or a slave – depending on the application, the I2S ports can operate simultaneously as either inputs or outputs. When configured as slaves, the I2S inputs/outputs can be independently clocked by up to two external masters. In addition, MCLK can be output from the module to provide a reference clock source to an external ADC or DAC. MCLK can also be input to the module to provide a reference clock from an external source.

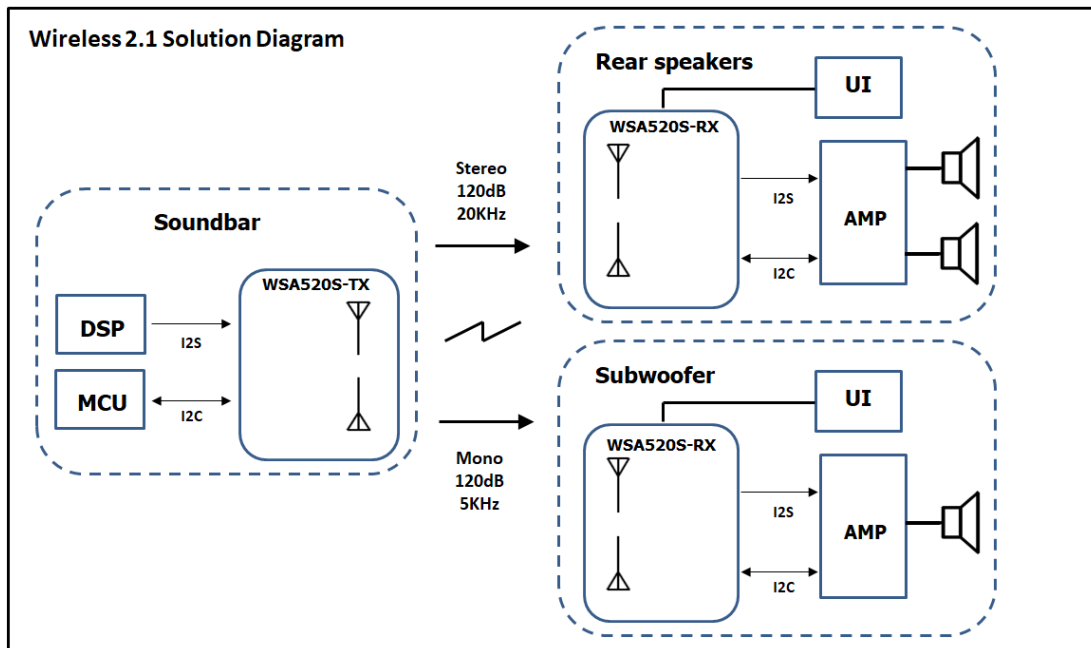
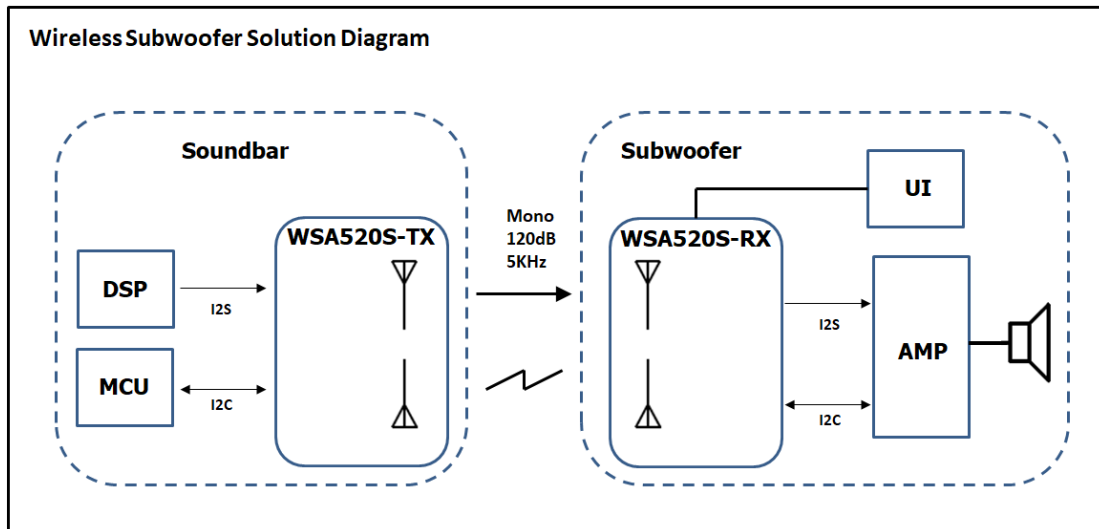

5. Electrical Specifications

5-1. Absolute Maximum Ratings

Absolute Maximum Ratings (AMR) are stress ratings only. AMR corresponds to the maximum value that can be applied without leading to instantaneous or very short-term unrecoverable hard failure (destructive breakdown). Stresses beyond those listed under AMR may cause permanent damage to the device.

Functional operation of the device at these or any other conditions beyond those indicated under "Recommended Operating Range" is not implied. Exposure to absolute-maximum-rated conditions for extended periods may adversely affect device reliability.

Device functional operating limits and guaranteed performance specifications are given under Electrical Characteristics at the test conditions specified.

CONDITION	MIN	MAX
+5 Supply Voltage Input	-0.3V	6.0V
Input Voltage Range – Digital Inputs	-0.3V	3.6V
Input Voltage Range – Analog Inputs	-0.3V	3.6V
Operating Temperature	-5°C	+40°C
Storage Temperature	-40°C	+85°C
Static Discharge Voltage*		+/-30KV

Notes;

* System level ESD : IEC 61000-4-2; C = 150pF, R = 330Ω

5-2. Recommended operating Range

PARAMETER	MIN	TYP	MAX	UNIT
VDD, +5V Supply Input voltage	4.5	5	5.5	V
Operating Temperature	-5°C		+40°C	°C

5-3. Electrical Characteristics – DC

Typical specifications at TA = 25°C, VDD = 5V

PARAMETER	CONDITION	MIN	TYP	MAX	UNIT
Current	Continuous TX (TX Module)		400		mA
	Linked status for TX		57		
	Searching for TX		86		
	Continuous RX		26		
	Linked status for RX		26		

	Searching for RX		75		
CMOS I/O Logic Levels – VDDIO 3.3V	Input Voltage Logic Low, VIL			0.6	V
	Input Voltage Logic High, VIH	VDDIO - 0.6V			
	Output Voltage Logic Low, VOL			0.3	
	Output Voltage Logic High, VOH	VDDIO - 0.3V			

5-4. Electrical Characteristics – RF TX

Operating Conditions: TA = -5°C to +40 °C, RF Freq = 5150~5250/5725-5875MHz, measured to the RF conducted ports.
 Typical specifications at TA = 25°C, VDD = 5V

PARAMETER	CONDITION		MIN	TYP	MAX	UNIT
RF Channel Frequency Range	Low band		5150		5250	MHz
	High band		5725		5875	
RF bandwidth				4		dBm
RF Modulation scheme	Phi/4-DQPSK					
RF carrier scheme	DSC (Dual side carrier)					
TX Output power (Aging)	Power setting	High-band, 0x13		8		dBm
		Low-band, 0x0b		8		
TX Spurious (harmonic)	2nd				-55	dBm
	3rd				-55	dBm
RF I/O Impedance	ANT1, ANT2			50		ohm
LO leakage				-20		dBc

5-5. Electrical Characteristics – RF RX

Operating Conditions: TA = -5°C to +40 °C, RF Freq = 5150~5250/5725-5875MHz, measured to the RF conducted ports.
 Typical specifications at TA = 25°C, VDD =5V

PARAMETER	CONDITION		MIN	TYP	MAX	UNIT
RF Channel Frequency Range	Low band		5150		5250	MHz
	High band		5725		5825	
RX Sensitivity	DSC (Dual Sub-Carrier)			-86		dBm
Max input signal	LNA = low gain mode, min IF gain			-5		

Out-of-band blocker level	<5150 MHz, >5850 MHz		-45		
	2400-2483.5 MHz		-20		
Spurious RF outputs	5150-5875 MHz			-65	
	<5150 MHz, >5875 MHz			-65	dBm
RF I/O Impedance	ANT1, ANT2		50		ohm

* The sensitivity been defined with BER <= 0.002.

5-6. Electrical Characteristics – RF PLL

Operating Conditions: TA = -5°C to +40 °C, RF Freq = 5150~5250/5725-5875MHz, measured to the RF conducted ports.

Typical specifications at TA = 25°C, VDD = 5V

PARAMETER	CONDITION	MIN	TYP	MAX	UNIT
RF Channel Frequency Range	Low band	5150		5250	MHz
	High band	5725		5875	
RF Channel frequency resolution (raster)			1		MHz
Local Frequency error			5	10	ppm
Crystal Oscillator Frequency	External crystal		16		MHz
RF I/O Impedance	ANT1, ANT2		50		ohm

5-7. Electrical Characteristics – Audio C/CS

PARAMETER	CONDITION	MIN	TYP	MAX	UNIT
Audio Frequency Range	+/- 1dB	20		20,000	Hz
Audio Interface Resolution				24	bit
OTA Dynamic Range			120		dB
OTA Signal to Noise Ratio			120		dB

5-8. I²S Communication Interface Timing

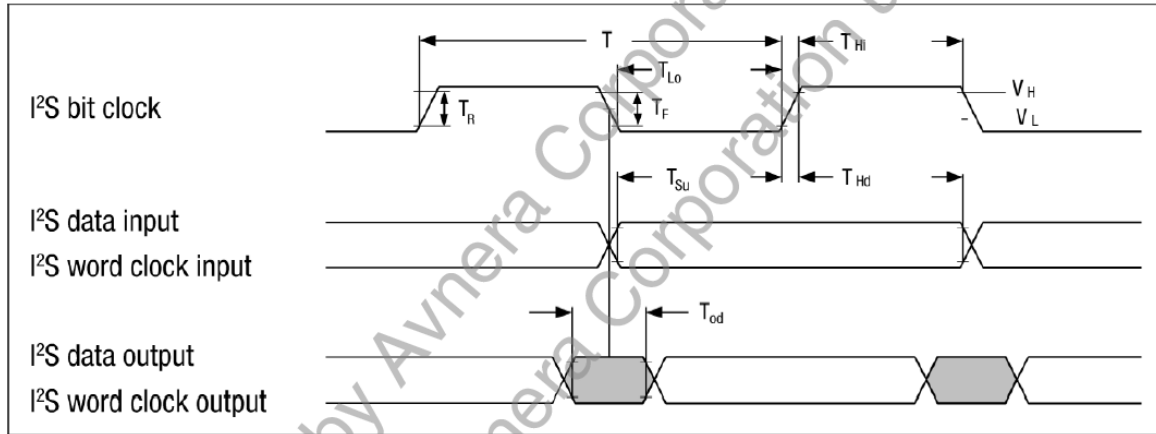

I²S Interface Timing

	PARAMETER	MIN	TYP	MAX	UNIT	Notes
V _L	Low voltage level	-0.3	0	0.4	V	
V _H	High voltage level	2.7	3.3	3.6	V	
T	Clock period		325.5		ns	1/3.072MHz
T _{Lo}	Clock low period	0.4T		0.6T		
T _{Hi}	Clock high period	0.4T		0.6T		
T _R	Rise time			50	ns	
T _F	Fall time			50	ns	
T _{Su}	Setup time	25			ns	
T _{Hd}	Hold time	25			ns	
T _{Od}	Output delay	-25		25	ns	
	Bit clocks/Word clock		64			

5-9. I²C Slave Communication Interface Timing

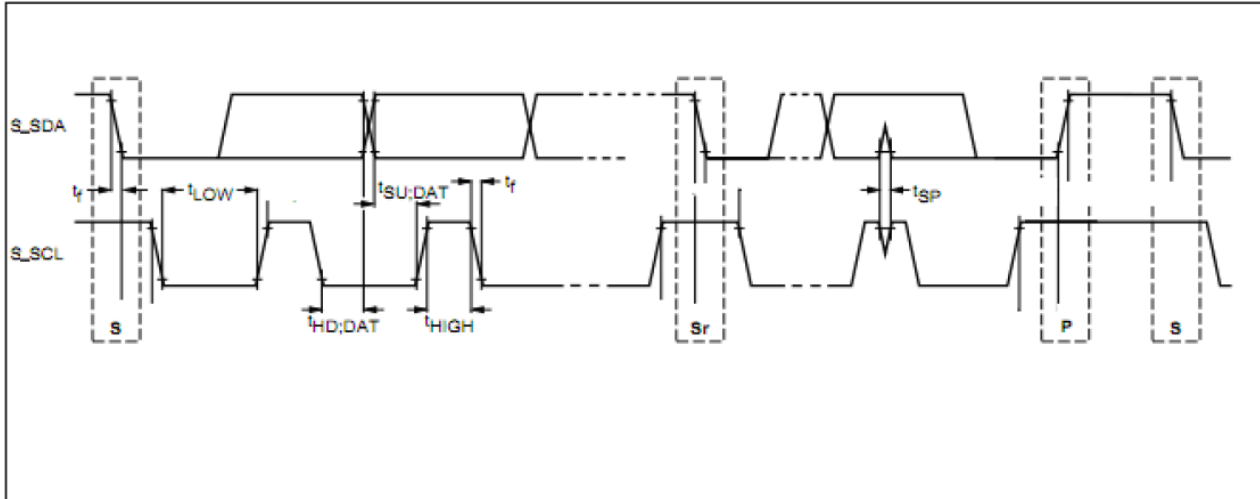

I²C Slave Interface Timing (Fast-Mode)

	Parameter	MIN	MAX	UNIT
V _{IL}	Low level input voltage	0.3	0.6	V
V _{IH}	High level input voltage	2.7	3.6	V
V _{OH}	Low level output voltage At 1mA sink current	0	0.3	V
t _{of}	Output fall time from V _{IHmin} to V _{ILmax} with a bus capacitance from 10pF to 400pF	0	250	ns
t _{SP}	Pulse width of spike which must be suppressed by the input filter	0	50	ns
f _{SCL}	S_SCL clock frequency	0	400	KHz
t _{LOW}	Low period of the S_SCL clock	1.3		us
T _{HIGH}	High period of the S-SCL clock	0.6		us
t _{HD;DAT}	Data hold time	100		ns
T _{SU;DAT}	Data set-up time	100		ns

6. Certificate Statement

FCC MODULAR APPROVAL INFORMATION EXAMPLES for Manual

This device complies with Part 15 of the FCC Rules. Operation is subject to the following two conditions:

- (1) This device may not cause harmful interference.
- (2) This device must accept any interference received, including interference that may cause undesired operation.

CAUTION: Changes or modifications not expressly approved by the party responsible for compliance could void the user's authority to operate the equipment.

NOTE: This equipment has been tested and found to comply with the limits for a Class B digital device, pursuant to Part 15 of the FCC Rules. These limits are designed to provide reasonable protection against harmful interference in a residential installation. This equipment generates uses and can radiate radio frequency energy and, if not installed and used in accordance with the instructions, may cause harmful interference to radio communications. However, there is no guarantee that interference will not occur in a particular installation. If this equipment does cause harmful interference to radio or television reception, which can be determined by turning the equipment off and on, the user is encouraged to try to correct the interference by one or more of the following measures:

- Reorient or relocate the receiving antenna.
- Increase the separation between the equipment and receiver.
- Connect the equipment into an outlet on a circuit different from that to which the receiver is connected.
- Consult the dealer or an experienced radio/TV technician for help.

FCC Radiation Exposure Statement:

This equipment complies with FCC radiation exposure limits set forth for an uncontrolled environment. This equipment should be installed and operated with minimum distance 20cm between the radiator & your body.

OEM INTEGRATION INSTRUCTIONS:

This device is intended only for OEM integrators under the following conditions:

The module must be installed in the host equipment such that 20 cm is maintained between the antenna and users, and the transmitter module may not be co-located with any other transmitter or antenna. The module shall be only used with the internal on-board antenna that has been originally tested and certified with this module. External antennas are not supported. As long as these 3 conditions above are met, further transmitter test will not be required.

However, the OEM integrator is still responsible for testing their end-product for any additional compliance requirements required with this module installed (for example, digital device emissions, PC peripheral requirements, etc.). The end-product may need Verification testing, Declaration of Conformity testing, a Permissive Class II Change or new Certification. Please involve a FCC certification specialist in order to determine what will be exactly applicable for the end-product.

Validity of using the module certification:

In the event that these conditions cannot be met (for example certain laptop configurations or co-location with another transmitter), then the FCC authorization for this module in combination with the host equipment is no longer considered valid and the FCC ID of the module cannot be used on the final product. In these circumstances, the OEM integrator will be responsible for re-evaluating the end product (including the transmitter) and obtaining a separate FCC authorization. In such cases, please involve a FCC certification specialist in order to determine if a Permissive Class II Change or new Certification is required.

Upgrade Firmware:

The software provided for firmware upgrade will not be capable to affect any RF parameters as certified for the FCC for this module, in order to prevent compliance issues.

End product labeling:

This transmitter module is authorized only for use in device where the antenna may be installed such that 20 cm may be maintained between the antenna and users. The final end product must be labeled in a visible area with the following: "Contains FCC ID: A3LWSA520S".

Information that must be placed in the end user manual:

The OEM integrator has to be aware not to provide information to the end user regarding how to install or remove this RF module in the user's manual of the end product which integrates this module. The end user manual shall include all required regulatory information/warning as show in this manual.

FCC MODULAR APPROVAL INFORMATION EXAMPLES for Manual

This device complies with Part 15 of the FCC Rules. Operation is subject to the following two conditions:

- (1) This device may not cause harmful interference.
- (2) This device must accept any interference received, including interference that may cause undesired operation.

CAUTION: Changes or modifications not expressly approved by the party responsible for compliance could void the user's authority to operate the equipment.

NOTE: This equipment has been tested and found to comply with the limits for a Class B digital device, pursuant to Part 15 of the FCC Rules. These limits are designed to provide reasonable protection against harmful interference in a residential installation. This equipment generates uses and can radiate radio frequency energy and, if not installed and used in accordance with the instructions, may cause harmful interference to radio communications. However, there is no guarantee that interference will not occur in a particular installation. If this equipment does cause harmful interference to radio or television reception, which can be determined by turning the equipment off and on, the user is encouraged to try to correct the interference by one or more of the following measures:

- Reorient or relocate the receiving antenna.
- Increase the separation between the equipment and receiver.
- Connect the equipment into an outlet on a circuit different from that to which the receiver is connected.
- Consult the dealer or an experienced radio/TV technician for help.

WARNING

Changes or modifications not expressly approved by the manufacturer could void the user's authority to operate the equipment.

“CAUTION : Exposure to Radio Frequency Radiation.

Antenna shall be mounted in such a manner to minimize the potential for human contact during normal operation. The antenna should not be contacted during operation to avoid the possibility of exceeding the FCC radio frequency exposure limit.

IC Information

This device complies with Industry Canada license-exempt RSS standard(s). Operation is subject to the following two conditions:

- (1) this device may not cause interference, and
- (2) this device must accept any interference, including interference that may cause undesired operation of the device.

Cet appareil est conforme avec Industrie Canada exempts de licence standard RSS (s). L'opération est soumise aux deux conditions suivantes:

- (1) cet appareil ne peut causer d'interférences, et*
- (2) cet appareil doit accepter toute interférence, y compris les interférences qui peuvent causer un mauvais fonctionnement de l'appareil.*

The end product must be labeled to display the Industry Canada certification number of the module.

Contains transmitter module IC: 649E-WSA520S

*Le dispositif d'accueil doivent être étiquetés pour afficher le numéro de certification d'Industrie Canada du module.
Contient module émetteur IC: 649E-WSA520S*

*** This device is going to be operated in 5 150 MHz ~ 5 250 MHz frequency range, it is restricted in indoor environment only.**

Information for OEM Integrator

This device is intended only for OEM integrators under the following conditions:

- 1) The antenna must be installed such that 20 cm is maintained between the antenna and users, and
- 2) The transmitter module may not be co-located with any other transmitter or antenna.

End product labelling

The label for end product must include

“Contains FCC ID: A3LWSA520S, Contains IC: 649E-WSA520S”.

“CAUTION: Exposure to Radio Frequency Radiation.

This equipment complies with FCC radiation exposure limits set forth for an uncontrolled environment. This equipment should be installed and operated with minimum distance of 20cm between the radiator and your body. This transmitter module is authorized only for use in device where the antenna may be installed such that 20 cm may be maintained between the antenna and users.”

Requirement per KDB996369 D03

2.2 List of applicable FCC rules

List the FCC rules that are applicable to the modular transmitter. These are the rules that specifically establish the bands of operation, the power, spurious emissions, and operating fundamental frequencies. DO NOT list compliance to unintentional-radiator rules (Part 15 Subpart B) since that is not a condition of a module grant that is extended to a host manufacturer. See also Section 2.10 below concerning the need to notify host manufacturers that further testing is required.³

Explanation: This module meets the requirements of FCC part 15C(15.247). part 15E(15.407)

2.3 Summarize the specific operational use conditions

Describe use conditions that are applicable to the modular transmitter, including for example any limits on antennas, etc. For example, if point-to-point antennas are used that require reduction in power or compensation for cable loss, then this information must be in the instructions. If the use condition limitations extend to professional users, then instructions must state that this information also extends to the host manufacturer's instruction manual. In addition, certain information may also be needed, such as peak gain per frequency band and minimum gain, specifically for master devices in

5 GHz DFS bands.

Explanation: The EUT has a Chip Antenna, and the antenna use a permanently attached antenna which is not replaceable.

2.4 Limited module procedures

If a modular transmitter is approved as a "limited module," then the module manufacturer is responsible for approving the host environment that the limited module is used with. The manufacturer of a limited module must describe, both in the filing and in the installation instructions, the alternative means that the limited module manufacturer uses to verify that the host meets the necessary requirements to satisfy the module limiting conditions.

A limited module manufacturer has the flexibility to define its alternative method to address the conditions that limit the initial approval, such as: shielding, minimum signaling amplitude, buffered modulation/data inputs, or power supply regulation. The alternative method could include that the limited module manufacturer reviews detailed test data or host designs prior to giving the host manufacturer approval.

This limited module procedure is also applicable for RF exposure evaluation when it is necessary to demonstrate compliance in a specific host. The module manufacturer must state how control of the product into which the modular transmitter will be installed will be maintained such that full compliance of the product is always ensured. For additional hosts other than the specific host originally granted with a limited module, a Class II permissive change is required on the module grant to register the additional host as a specific host also approved with the module.

Explanation: The module is not a limited module.

2.5 Trace antenna designs

For a modular transmitter with trace antenna designs, see the guidance in Question 11 of KDB Publication 996369 D02 FAQ – Modules for Micro-Strip Antennas and traces. The integration information shall include for the TCB review the integration instructions for the following aspects:

layout of trace design, parts list (BOM), antenna, connectors, and isolation requirements.

- a) Information that includes permitted variances (e.g., trace boundary limits, thickness, length, width, shape(s), dielectric constant, and impedance as applicable for each type of antenna);
- b) Each design shall be considered a different type (e.g., antenna length in multiple(s) of frequency, the wavelength, and antenna shape (traces in phase) can affect antenna gain and must be considered);
- c) The parameters shall be provided in a manner permitting host manufacturers to design the printed circuit (PC) board layout;
- d) Appropriate parts by manufacturer and specifications;
- e) Test procedures for design verification; and
- f) Production test procedures for ensuring compliance.

The module grantee shall provide a notice that any deviation(s) from the defined parameters of the antenna trace, as described by the instructions, require that the host product manufacturer must notify the module grantee that they wish to change the antenna trace design. In this case, a Class II permissive change application is required to be filed by the grantee, or the host manufacturer can take responsibility through the change in FCC ID (new application) procedure followed by a Class II permissive change application.

Explanation: Yes, The module with trace antenna designs, and This manual has been shown the layout of trace design, antenna, connectors, and isolation requirements.

2.6 RF exposure considerations

It is essential for module grantees to clearly and explicitly state the RF exposure conditions that permit a host product manufacturer to use the module. Two types of instructions are required for RF exposure information: (1) to the host product manufacturer, to define the application conditions (mobile, portable – xx cm from a person's body); and (2) additional text needed for the host product manufacturer to provide to end users in their end-product manuals. If RF exposure statements and use conditions are not provided, then the host product manufacturer is required to take responsibility of the module through a change in FCC ID (new application).

Explanation: This module complies with FCC RF radiation exposure limits set forth for an uncontrolled environment, This equipment should be installed and operated with a minimum distance of 20 centimeters between the radiator and your body." This module is designed to comply with the FCC statement, FCC ID is: A3LWSA520S.

2.7 Antennas

A list of antennas included in the application for certification must be provided in the instructions. For modular transmitters approved as limited modules, all applicable professional installer instructions must be included as part of the information to the host product manufacturer. The antenna list shall also identify the antenna types (monopole, PIFA, dipole, etc. (note that for example an “omni-directional antenna” is not considered to be a specific “antenna type”)).

For situations where the host product manufacturer is responsible for an external connector, for example with an RF pin and antenna trace design, the integration instructions shall inform the installer that unique antenna connector must be used on the Part 15 authorized transmitters used in the host product. The module manufacturers shall provide a list of acceptable unique connectors.

Explanation: The EUT has a Chip Antenna, and the antenna use a permanently attached antenna which is unique.

2.8 Label and compliance information

Grantees are responsible for the continued compliance of their modules to the FCC rules. This includes advising host product manufacturers that they need to provide a physical or e-label stating “Contains FCC ID” with their finished product. See Guidelines for Labeling and User Information for RF Devices – KDB Publication 784748.

Explanation: The host system using this module, should have label in a visible area indicated the following texts: “Contains FCC ID: A3LWSA520S, Contains IC: 649E-WSA520S”

2.9 Information on test modes and additional testing requirements

Additional guidance for testing host products is given in KDB Publication 996369 D04 Module Integration Guide. Test modes should take into consideration different operational conditions for a stand-alone modular transmitter in a host, as well as for multiple simultaneously transmitting modules or other transmitters in a host product. The grantee should provide information on how to configure test modes for host product evaluation for different operational conditions for a stand-alone modular transmitter in a host, versus with multiple, simultaneously transmitting modules or other transmitters in a host.

Grantees can increase the utility of their modular transmitters by providing special means, modes, or instructions that simulates or characterizes a connection by enabling a transmitter. This can greatly simplify a host manufacturer’s determination that a module as installed in a host complies with FCC requirements.

Explanation: Top band can increase the utility of our modular transmitters by providing instructions that simulates or characterizes a connection by enabling a transmitter.

2.10 Additional testing, Part 15 Subpart B disclaimer

The grantee should include a statement that the modular transmitter is only FCC authorized for the specific rule parts (i.e., FCC transmitter rules) listed on the grant, and that the host product manufacturer is responsible for compliance to any other FCC rules that apply to the host not covered by the modular transmitter grant of certification. If the grantee markets their product as being Part 15 Subpart B compliant (when it also contains unintentional-radiator digital circuitry), then the grantee shall provide a notice stating that the final host product still requires Part 15 Subpart B compliance testing with the modular transmitter installed.

Explanation: The module without unintentional-radiator digital circuitry, so the module does not require an evaluation by FCC Part 15 Subpart B. The host should be evaluated by the FCC Subpart B.