

TEST REPORT

of

FCC Part 15 Subpart E §15.407 / RSS-210 Issue 8, RSS-Gen Issue 3

FCC ID/IC Certification : A3LWIDT30Q / 649E-WIDT30Q

Equipment Under Test : WiFi Module
Model Name : WIDT30Q
Applicant : SAMSUNG ELECTRONICS CO., LTD.
Manufacturer : SAMSUNG ELECTRONICS CO., LTD.
Date of Test(s) : 2013. 12. 05 ~ 2013. 12. 30
Date of Issue : 2013. 12. 31

In the configuration tested, the EUT complied with the standards specified above.

Tested By:



Wonjun Sim

Date

2013. 12. 31

Approved By:



Feel Jeong

Date

2013. 12. 31

The results shown in this test report refer only to the sample(s) tested unless otherwise stated. This test report cannot be reproduced, except in full, without prior written permission of the Company.

Table of contents

1. General information -----	3
2. Transmitter radiated spurious emissions and conducted spurious emission -----	7
3. 26 dB Bandwidth and 99 % Occupied bandwidth -----	27
4. Output power -----	86
5. Peak power spectral density -----	104
6. Peak excursion -----	136
7. Transmitter AC Power Line Conducted Emission-----	159

The results shown in this test report refer only to the sample(s) tested unless otherwise stated. This test report cannot be reproduced, except in full, without prior written permission of the Company.

1. General information

1.1 Testing laboratory

SGS Korea Co., Ltd. (Gunpo Laboratory).

- Wireless Div. 3FL, 18-34, Sanbon-dong, Gunpo-si, Gyeonggi-do, Korea 435-040 (Lab)
- Wireless Div. 1FL, 18-34, Sanbon-dong, Gunpo-si, Gyeonggi-do, Korea 435-040 (Chamber)

All SGS services are rendered in accordance with the applicable SGS conditions of service available on request and accessible at <http://www.sgs.com/en/Terms-and-Conditions.aspx>.

Phone No. : +82 31 428 5700

Fax No. : +82 31 427 2371

1.2 Details of applicant

Applicant : SAMSUNG ELECTRONICS CO., LTD.

Address : 129, Samsung-ro, Maetan-Dong, Yeongtong-gu, Suwon-si, Gyeonggi-do, 443-742
Rep. of Korea

Contact Person : Lee, Jaywoo

Phone No. : +82 31 277 2659

1.3. Description of EUT

Kind of Product	WiFi Module	
Model Name	WIDT30Q	
Power Supply	DC 5.0 V	
Frequency Range	2 412 MHz ~ 2 462 MHz (11b/g/n_HT20), 2 422 MHz ~ 2 452 MHz (11n_HT40), 5 745 MHz ~ 5 825 MHz (11a/n_HT20), 5 755 MHz ~ 5 795 MHz (11n_HT40), 5 180 MHz ~ 5 240 MHz (11a/n_HT20 – Non DFS), 5 190 MHz ~ 5 230 MHz (11n_HT40 – Non DFS), 5 260 MHz ~ 5 320 MHz (11a/n_HT20 – DFS), 5 270 MHz ~ 5 310 MHz (11n_HT40 – DFS), 5 500 MHz ~ 5 700 MHz (11a/n_HT20 – DFS), 5 510 MHz ~ 5 670 MHz (11n_HT40 – DFS)	
Modulation Technique	DSSS, OFDM, GFSK, $\pi/4$ DQPSK, 8DPSK	
Number of Channels	11 channel (11b/g/n_HT20), 7 channel (11n_HT40), 5 channel (11a/n_HT20), 2 channel (11n_HT40), 4 channel (11a/n_HT20–Non DFS), 2 channel (11n_HT40 – Non DFS), 15 channel (11a/n_HT20 – DFS), 7 channel (11n_HT40 – DFS)	
Antenna Type	Internal type (MIMO - 2 Tx / 2 Rx)	
Antenna Gain	Ant0: 2 402 MHz ~ 2 480 MHz: 2.05 dB i, 5 180 MHz ~ 5 320 MHz: 2.69 dB i, 5 500 MHz ~ 5 700 MHz: -0.26 dB i, 5 745 MHz ~ 5 805 MHz: 1.35 dB i	Ant1: 2 402 MHz ~ 2 480 MHz: 0.94 dB i, 5 180 MHz ~ 5 320 MHz: 2.50 dB i, 5 500 MHz ~ 5 700 MHz: -1.66 dB i, 5 745 MHz ~ 5 805 MHz: -0.90 dB i

1.4. Declaration by the manufacturer

- EUT is SLAVE without DFS and TPC.

- Duty Cycle \geq 98 percent

The results shown in this test report refer only to the sample(s) tested unless otherwise stated. This test report cannot be reproduced, except in full, without prior written permission of the Company.

1.5. Test equipment list

Equipment	Manufacturer	Model	S/N	Cal Date	Cal Interval	Cal Due.
Signal Generator	R&S	SMR40	100272	Aug. 23, 2013	Annual	Aug. 23, 2014
Spectrum Analyzer	Agilent	N9030A	US51350132	Oct. 08, 2013	Annual	Oct. 08, 2014
Spectrum Analyzer	R&S	FSW43	100637	Jul. 26, 2013	Annual	Jul. 26, 2014
Spectrum Analyzer	R&S	FSL6	100639	Jun. 26, 2013	Annual	Jun. 26, 2014
Attenuator	AEROFLEX / INMET	26A-10dB	3	Apr. 05, 2013	Annual	Apr. 05, 2014
Attenuator	AEROFLEX / INMET	18N-20dB	3	Apr. 01, 2013	Annual	Apr. 01, 2014
Power Divider	KRYTAR	6005265	144967	May 29, 2013	Annual	May 29, 2014
High Pass Filter	Wainwright	WHK7.5/26.5G-6SS	11	Jun. 08, 2013	Annual	Jun. 08, 2014
Low Pass Filter	Mini circuits	NLP-1200+	V8979400903-2	Mar. 30, 2013	Annual	Mar. 30, 2014
Power Sensor	R&S	NRP-Z81	100669	Apr. 05, 2013	Annual	Apr. 05, 2014
DC Power Supply	Agilent	U8002A	MY50060028	Mar. 28, 2013	Annual	Mar. 28, 2014
Preamplifier	H.P.	8447F	2944A03909	Jun. 28, 2013	Annual	Jun. 28, 2014
Preamplifier	R&S	SCU 18	10117	Jan. 14, 2013	Annual	Jan. 14, 2014
Preamplifier	MITEQ Inc.	JS44-18004000-35-8P	1546891	Jun. 13, 2013	Annual	Jun. 13, 2014
Test Receiver	R&S	ESU26	100109	Feb. 28, 2013	Annual	Feb. 28, 2014
Bilog Antenna	SCHWARZBECK MESSELEKTRONIK	VULB9163	390	Apr. 19, 2012	Biennial	Apr. 19, 2014
Horn Antenna	R&S	HF906	100326	Dec. 10, 2013	Biennial	Dec. 10, 2015
Horn Antenna	SCHWARZBECK MESSELEKTRONIK	BBHA9170	BBHA9170431	Aug. 24, 2012	Biennial	Aug. 24, 2014
Band Reject Filter	Wainwright Instrument GmbH	WRCJV5150/5350-5130/ 5370-50/16SS	1	Sep. 28, 2013	Annual	Sep. 28, 2014
Band Reject Filter	Wainwright Instrument GmbH	WRCJV5470/5725-5450/ 5745-50/20SS	1	Sep. 28, 2013	Annual	Sep. 28, 2014
Antenna Master	INNCO	MM4000	N/A	N.C.R.	N/A	N.C.R.
Turn Table	INNCO	DS 1200S	N/A	N.C.R.	N/A	N.C.R.
Anechoic Chamber	SY Corporation	L × W × H (6.5 m × 3.5 m × 3.5 m)	N/A	N.C.R.	N/A	N.C.R.
EMI Test Receiver	R&S	ESHS10	863365/018	Jun. 27, 2013	Annual	Jun. 27, 2014
Two-Line V-Network	R&S	ENV216	100190	Jan. 04, 2013	Annual	Jan. 04, 2014
Anechoic Chamber	SY Corporation	L × W × H (9.6 m × 6.4 m × 6.4 m)	N/A	N.C.R.	N/A	N.C.R.

The results shown in this test report refer only to the sample(s) tested unless otherwise stated. This test report cannot be reproduced, except in full, without prior written permission of the Company.

► Support equipment

Description	Manufacturer	Model	Serial Number / FCC ID
N/A	-	-	-

1.6. Summary of test result

The EUT has been tested according to the following specifications:

APPLIED STANDARD:FCC Part15, RSS-210,RSS-Gen			
Section in FCC 15	Section in RSS-210 RSS-Gen	Test Item	Result
15.205(a) 15.209(a) 15.407(b)(1) 15.407(b)(2) 15.407(b)(3)	RSS-Gen 7 A9.2(1) A9.2(2) A9.2(3)	Transmitter radiated spurious emissions and Conducted spurious emission	Complied
15.407(a)(1) 15.407(a)(2)	A9.2(1) A9.2(2) A9.2(3)	Output power	Complied
15.407(a)(1) 15.407(a)(2)	A9.2(1) A9.2(2) A9.2(3)	Peak power spectral density	Complied
15.407(a)(6)	-	Peak excursion	Complied
15.207	RSS-Gen 7.2.4	Transmitter AC Power Line Conducted Emission	Complied

1.7. Test Procedure(s)

The measurement procedures described in the American National Standard for Methods of Measurement of Radio-Noise Emission from Low-Voltage Electrical and Electronic Equipment in the Range of 9 kHz to 40 GHz (ANSI C63.4-2003) and the guidance provided in KDB 789033_v01r03 were used in the measurement of the DUT.

The results shown in this test report refer only to the sample(s) tested unless otherwise stated. This test report cannot be reproduced, except in full, without prior written permission of the Company.

1.8. Sample calculation

Where relevant, the following sample calculation is provided:

1.8.1. Conducted test

offset value (dB) = Attenuator (dB) + Cable loss (dB)

1.8.2. Radiation test

Field strength level (dB μ V/m) = Measured level (dB μ V) + Antenna factor (dB) + Cable loss (dB) - amplifier (dB)

1.9. Test report revision

Revision	Report number	Description
0	F690501/RF-RTL007279	Initial

The results shown in this test report refer only to the sample(s) tested unless otherwise stated. This test report cannot be reproduced, except in full, without prior written permission of the Company.

2. Transmitter radiated spurious emissions and conducted spurious emission

2.1. Test setup

2.1.1. Transmitter radiated spurious emissions

The diagram below shows the test setup that is utilized to make the measurements for emission from 30 MHz to 1 GHz Emissions.

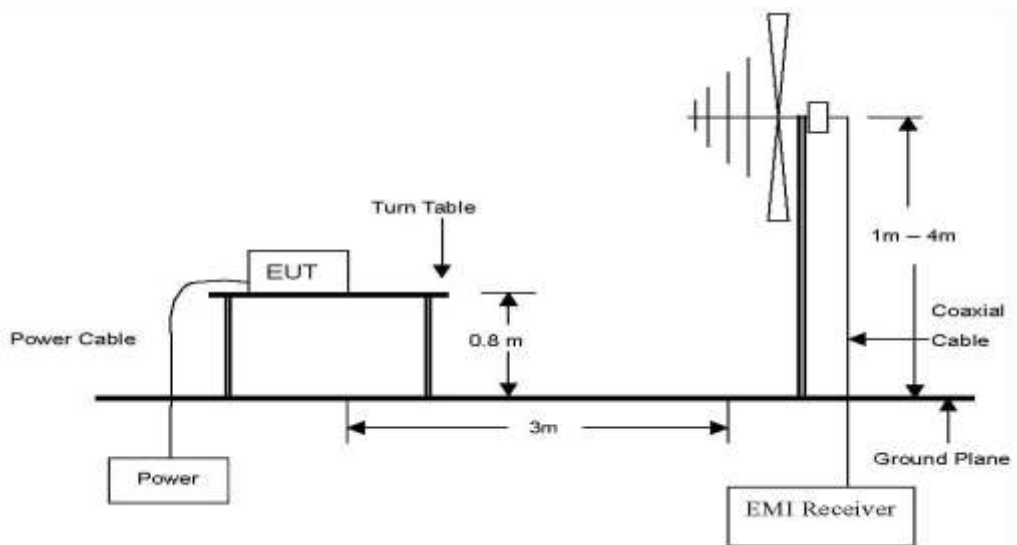

The diagram below shows the test setup that is utilized to make the measurements for emission. The spurious emissions were investigated from 1 GHz to the 10th harmonic of the highest fundamental frequency or 40 GHz, whichever is lower.

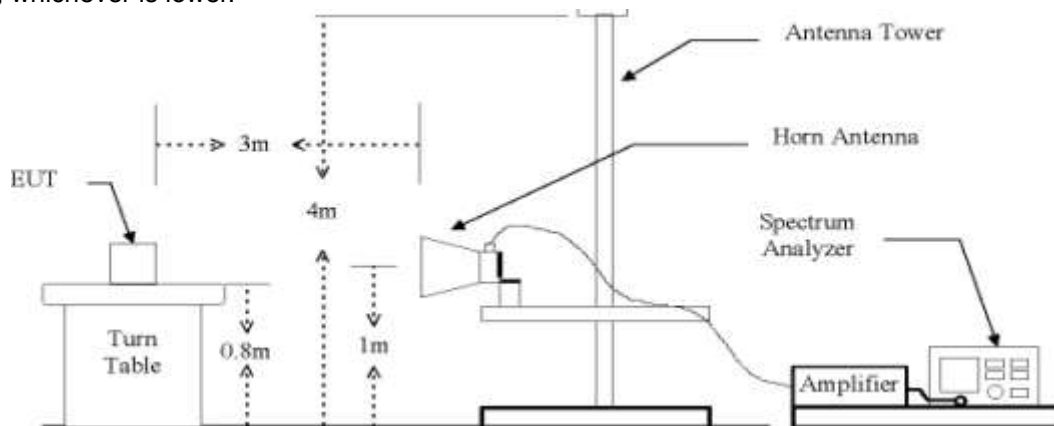

The results shown in this test report refer only to the sample(s) tested unless otherwise stated. This test report cannot be reproduced, except in full, without prior written permission of the Company.

2.2. Limit

15.407(b)(1) For transmitters operating in the 5.15 ~ 5.25 GHz band: all emissions outside of the 5.15 ~ 5.35 GHz band shall not exceed an EIRP of -27 dB m/MHz.

15.407(b)(2) For transmitters operating in the 5.25 ~ 5.35 GHz band: all emissions outside of the 5.15 ~ 5.35 GHz band shall not exceed an EIRP of -27 dB m/MHz. Devices operating in the 5.25 ~ 5.35 GHz band that generate emissions in the 5.15 ~ 5.25 GHz band must meet all applicable technical requirements for operation in the 5.15 ~ 5.25 GHz band (including indoor use) or alternatively meet an out-of-band emission EIRP limit of -27 dB m/MHz in the 5.15 ~ 5.25 GHz band.

15.407(b)(3) For transmitters operating in the 5.47 ~ 5.725 GHz band: all emissions outside of the 5.47 ~ 5.725 GHz band shall not exceed an EIRP of -27 dB m/MHz.

According to § 15.209(a), Except as provided elsewhere in this Subpart, the emissions from an intentional radiator shall not exceed the field strength levels specified in the following table :

Frequency (MHz)	Distance (Meters)	Field Strength (dB μ V/m)	Field Strength (μ V/m)
30 - 88	3	40.0	100
88 - 216	3	43.5	150
216 - 960	3	46.0	200
Above 960	3	54.0	500

2.3. Test procedures

Conducted and Radiated emissions from the EUT were measured according to the dictates in section H of KDB 789033_v01r03.

All data rates and modes were investigated for conducted spurious emissions. The emissions of the configuration that produced the worst case emissions are reported in this section.

The results shown in this test report refer only to the sample(s) tested unless otherwise stated. This test report cannot be reproduced, except in full, without prior written permission of the Company.

2.3.1. Test procedures for radiated spurious emissions

1. The EUT was placed on the top of a rotating table 0.8 meters above the ground at a 3 meter anechoic chamber test site. The table was rotated 360 degrees to determine the position of the highest radiation.
2. During performing radiated emission below 1 GHz, the EUT was set 3 meters away from the interference receiving antenna, which was mounted on the top of a variable-height antenna tower. During performing radiated emission above 1 GHz, the EUT was set 3 meter away from the interference-receiving antenna.
3. The antenna is a broadband antenna, and its height is varied from one meter to four meters above the ground to determine the maximum value of the field strength. Both horizontal and vertical polarizations of the antenna are set to make the measurement.
4. For each suspected emission, the EUT was arranged to its worst case and then the antenna was tuned to heights from 1 meter to 4 meters and the table was turned from 0 degrees to 360 degrees to find the maximum reading.
5. The test-receiver system was set to Peak Detect Function and Specified Bandwidth with Maximum Hold Mode.
6. If the emission level of the EUT in peak mode was 10 dB lower than the limit specified, then testing could be stopped and the peak values of the EUT would be reported. Otherwise the emissions that did not have 10 dB margin would be re-tested one by one using peak, quasi-peak or average method as specified and then reported in a data sheet.

NOTE;

- The measurements for below 1 GHz

Compliance shall be demonstrated using CISPR quasi-peak detection; however, peak detection is permitted as an alternative to quasi-peak detection.

- The measurements for above 1 GHz

Peak emission levels are measured by setting the analyzer as follows:

Set to RBW = 1 MHz, VBW ≥ 3 MHz, Detector = Peak, Sweep time = auto, Trace mode= Max hold.

Average emission levels are measured by setting the analyzer as follows:

Set to RBW = 1 MHz, VBW ≥ 3 MHz, Detector = RMS, Averaging type = power(i.e., RMS), Sweep time = auto, Trace mode= trace average of at least 100 traces. If the transmission is not continuous, the number of traces shall be increased by a factor of 1/x, where x is the duty cycle.

If duty cycle < 98 percent, a correction factor shall be added to the measurement results.

- Power averaging(RMS) mode was used above, the correction factor is $10 \log(1/x)$, where x is the duty cycle.

To get a maximum emission level from the EUT, the EUT is manipulated through three orthogonal planes.

The results shown in this test report refer only to the sample(s) tested unless otherwise stated. This test report cannot be reproduced, except in full, without prior written permission of the Company.

2.4. Test result

Ambient temperature : (24 ± 2) °C
 Relative humidity : 49 % R.H.

2.4.1. Spurious radiated emission (Worst case configuration_11a mode_6Mbps_Middle channel)

The frequency spectrum from 30 MHz to 1 000 MHz was investigated. Emission levels are not reported much lower than the limits by over 30 dB. All reading values are peak values.

Radiated emissions			Ant	Correction factors		Total	Limit	
Frequency (MHz)	Reading (dB μ V)	Detect Mode	Pol.	AF (dB/m)	Amp gain+CL (dB)	Actual (dB uV/m)	Limit (dB uV/m)	Margin (dB)
42.53	34.69	Peak	H	14.44	-26.83	22.30	40.00	17.70
96.32	34.78	Peak	H	12.10	-26.28	20.60	43.50	22.90
230.83	34.54	Peak	V	12.69	-25.13	22.10	46.00	23.90
356.57	34.74	Peak	V	15.66	-24.90	25.50	46.00	20.50
767.69	34.53	Peak	V	21.59	-24.62	31.50	46.00	14.50
Above 800.00	Not detected	-	-	-	-	-	-	-

Remark:

1. All spurious emission at channels are almost the same below 1 GHz, So that the Middle channel was chose at representative in final test.
2. Actual = Reading + AF + AMP + CL

The results shown in this test report refer only to the sample(s) tested unless otherwise stated. This test report cannot be reproduced, except in full, without prior written permission of the Company.

2.4.2. Spurious radiated emission for above 1 GHz

ANT0

802.11a (Non-DFS) _6 Mbps

A. Low Channel (5 180 MHz)

Radiated Emissions			Ant	Correction Factors		Total	Limit	
Frequency (MHz)	Reading (dB uV)	Detect Mode	Pol.	AF (dB/m)	CL (dB)	Actual (dB uV/m)	Limit (dB uV/m)	Margin (dB)
*5 150.00	12.41	Peak	V	33.43	10.14	55.98	74.00	18.02
*5 150.00	4.20	Average	V	33.43	10.14	47.77	54.00	6.23
Frequency (MHz)	Reading (dB uV)	Detect Mode	Pol.	AF (dB/m)	Amp Gain+CL (dB)	Actual (dB uV/m)	Limit (dB uV/m)	Margin (dB)
10 360.05	47.27	Peak	V	37.58	-30.75	54.10	68.23	14.13
Above 10 400.00	Not Detected	-	-	-	-	-	-	-

B. Middle Channel (5 220 MHz)

Radiated Emissions			Ant	Correction Factors		Total	Limit	
Frequency (MHz)	Reading (dB uV)	Detect Mode	Pol.	AF (dB/m)	Amp Gain+CL (dB)	Actual (dB uV/m)	Limit (dB uV/m)	Margin (dB)
10 440.97	50.17	Peak	V	37.67	-31.04	56.80	68.23	11.43
Above 10 500.00	Not Detected	-	-	-	-	-	-	-

The results shown in this test report refer only to the sample(s) tested unless otherwise stated. This test report cannot be reproduced, except in full, without prior written permission of the Company.

C. High Channel (5 240 MHz)

Radiated Emissions			Ant	Correction Factors		Total	Limit	
Frequency (MHz)	Reading (dB uV)	Detect Mode	Pol.	AF (dB/m)	Amp Gain+CL (dB)	Actual (dB uV/m)	Limit (dB uV/m)	Margin (dB)
10 480.24	50.43	Peak	V	37.61	-31.10	56.94	68.23	11.30
Above 10 500.00	Not Detected	-	-	-	-	-	-	-

802.11a (DFS) _6 Mbps

A. Low Channel (5 260 MHz)

Radiated Emissions			Ant	Correction Factors		Total	Limit	
Frequency (MHz)	Reading (dB uV)	Detect Mode	Pol.	AF (dB/m)	Amp Gain+CL (dB)	Actual (dB uV/m)	Limit (dB uV/m)	Margin (dB)
10 519.93	49.90	Peak	V	37.52	-30.89	56.53	68.23	11.70
Above 10 600.00	Not Detected	-	-	-	-	-	-	-

B. Middle Channel (5 300 MHz)

Radiated Emissions			Ant	Correction Factors		Total	Limit	
Frequency (MHz)	Reading (dB uV)	Detect Mode	Pol.	AF (dB/m)	Amp Gain+CL (dB)	Actual (dB uV/m)	Limit (dB uV/m)	Margin (dB)
*10 600.61	43.99	Peak	V	37.63	-29.90	51.72	74.00	22.28
*10 600.61	30.15	Average	V	37.63	-29.90	37.88	54.00	16.12
Above 10 700.00	Not Detected	-	-	-	-	-	-	-

The results shown in this test report refer only to the sample(s) tested unless otherwise stated. This test report cannot be reproduced, except in full, without prior written permission of the Company.

C. High Channel (5 320 MHz)

Radiated Emissions			Ant	Correction Factors		Total	Limit	
Frequency (MHz)	Reading (dB uV)	Detect Mode	Pol.	AF (dB/m)	CL (dB)	Actual (dB uV/m)	Limit (dB uV/m)	Margin (dB)
*5 350.00	10.73	Peak	V	33.75	10.09	54.57	74.00	19.43
*5 350.00	4.04	Average	V	33.75	10.09	47.88	54.00	6.12
Frequency (MHz)	Reading (dB uV)	Detect Mode	Pol.	AF (dB/m)	Amp Gain+CL (dB)	Actual (dB uV/m)	Limit (dB uV/m)	Margin (dB)
*10 639.05	39.79	Peak	V	37.67	-29.95	47.51	74.00	26.49
*10 639.05	27.38	Average	V	37.67	-29.95	35.10	54.00	18.90
Above 10 700.00	Not Detected	-	-	-	-	-	-	-

802.11a (DFS) _6 Mbps

A. Low Channel (5 500 MHz)

Radiated Emissions			Ant	Correction Factors		Total	Limit	
Frequency (MHz)	Reading (dB uV)	Detect Mode	Pol.	AF (dB/m)	CL (dB)	Actual (dB uV/m)	Limit (dB uV/m)	Margin (dB)
*5 460.00	10.85	Peak	V	34.29	10.25	55.39	74.00	18.61
*5 460.00	3.41	Average	V	34.29	10.25	47.95	54.00	6.05
Frequency (MHz)	Reading (dB uV)	Detect Mode	Pol.	AF (dB/m)	Amp Gain+CL (dB)	Actual (dB uV/m)	Limit (dB uV/m)	Margin (dB)
*11 000.23	42.10	Peak	V	38.09	-27.68	52.51	74.00	21.49
*11 000.23	27.53	Average	V	38.09	-27.68	37.94	54.00	16.06
Above 11 100.00	Not Detected	-	-	-	-	-	-	-

The results shown in this test report refer only to the sample(s) tested unless otherwise stated. This test report cannot be reproduced, except in full, without prior written permission of the Company.

B. Middle Channel (5 580 MHz)

Radiated Emissions			Ant	Correction Factors		Total	Limit	
Frequency (MHz)	Reading (dB uV)	Detect Mode	Pol.	AF (dB/m)	Amp Gain+CL (dB)	Actual (dB uV/m)	Limit (dB uV/m)	Margin (dB)
*11 160.18	52.37	Peak	V	37.94	-27.78	62.53	74.00	11.47
*11 160.18	38.55	Average	V	37.94	-27.78	48.71	54.00	5.29
Above 11 200.00	Not Detected	-	-	-	-	-	-	-

C. High Channel (5 700 MHz)

Radiated Emissions			Ant	Correction Factors		Total	Limit	
Frequency (MHz)	Reading (dB uV)	Detect Mode	Pol.	AF (dB/m)	Amp Gain+CL (dB)	Actual (dB uV/m)	Limit (dB uV/m)	Margin (dB)
*11 400.12	47.97	Peak	V	37.92	-26.70	59.19	74.00	14.81
*11 400.12	34.07	Average	V	37.92	-26.70	45.29	54.00	8.71
Above 11 500.00	Not Detected	-	-	-	-	-	-	-

The results shown in this test report refer only to the sample(s) tested unless otherwise stated. This test report cannot be reproduced, except in full, without prior written permission of the Company.

ANT1
802.11a (Non-DFS) _6 Mbps
A. Low Channel (5 180 MHz)

Radiated Emissions			Ant	Correction Factors		Total	Limit	
Frequency (MHz)	Reading (dB uV)	Detect Mode	Pol.	AF (dB/m)	CL (dB)	Actual (dB uV/m)	Limit (dB uV/m)	Margin (dB)
*5 150.00	13.00	Peak	H	33.43	10.14	56.57	74.00	17.43
*5 150.00	4.05	Average	H	33.43	10.14	47.62	54.00	6.38
Frequency (MHz)	Reading (dB uV)	Detect Mode	Pol.	AF (dB/m)	Amp Gain+CL (dB)	Actual (dB uV/m)	Limit (dB uV/m)	Margin (dB)
10 360.06	47.94	Peak	V	37.58	-30.75	54.77	68.23	13.46
Above 10 400.00	Not Detected	-	-	-	-	-	-	-

B. Middle Channel (5 220 MHz)

Radiated Emissions			Ant	Correction Factors		Total	Limit	
Frequency (MHz)	Reading (dB uV)	Detect Mode	Pol.	AF (dB/m)	Amp Gain+CL (dB)	Actual (dB uV/m)	Limit (dB uV/m)	Margin (dB)
10 440.06	51.37	Peak	V	37.67	-31.04	58.00	68.23	10.23
Above 10 500.00	Not Detected	-	-	-	-	-	-	-

The results shown in this test report refer only to the sample(s) tested unless otherwise stated. This test report cannot be reproduced, except in full, without prior written permission of the Company.

C. High Channel (5 240 MHz)

Radiated Emissions			Ant	Correction Factors		Total	Limit	
Frequency (MHz)	Reading (dB uV)	Detect Mode	Pol.	AF (dB/m)	Amp Gain+CL (dB)	Actual (dB uV/m)	Limit (dB uV/m)	Margin (dB)
10 480.13	51.64	Peak	V	37.61	-31.10	58.15	68.23	10.08
Above 10 500.00	Not Detected	-	-	-	-	-	-	-

802.11a (DFS) _6 Mbps
A. Low Channel (5 260 MHz)

Radiated Emissions			Ant	Correction Factors		Total	Limit	
Frequency (MHz)	Reading (dB uV)	Detect Mode	Pol.	AF (dB/m)	Amp Gain+CL (dB)	Actual (dB uV/m)	Limit (dB uV/m)	Margin (dB)
10 520.16	50.32	Peak	V	37.52	-30.89	56.95	68.23	11.28
Above 10 600.00	Not Detected	-	-	-	-	-	-	-

B. Middle Channel (5 300 MHz)

Radiated Emissions			Ant	Correction Factors		Total	Limit	
Frequency (MHz)	Reading (dB uV)	Detect Mode	Pol.	AF (dB/m)	Amp Gain+CL (dB)	Actual (dB uV/m)	Limit (dB uV/m)	Margin (dB)
*10 600.41	44.56	Peak	V	37.63	-29.90	52.29	74.00	21.71
*10 600.41	31.27	Average	V	37.63	-29.90	39.00	54.00	15.00
Above 10 700.00	Not Detected	-	-	-	-	-	-	-

The results shown in this test report refer only to the sample(s) tested unless otherwise stated. This test report cannot be reproduced, except in full, without prior written permission of the Company.

C. High Channel (5 320 MHz)

Radiated Emissions			Ant	Correction Factors		Total	Limit	
Frequency (MHz)	Reading (dB uV)	Detect Mode	Pol.	AF (dB/m)	CL (dB)	Actual (dB uV/m)	Limit (dB uV/m)	Margin (dB)
*5 350.00	12.62	Peak	H	33.75	10.09	56.46	74.00	17.54
*5 350.00	4.01	Average	H	33.75	10.09	47.85	54.00	6.15
Frequency (MHz)	Reading (dB uV)	Detect Mode	Pol.	AF (dB/m)	Amp Gain+CL (dB)	Actual (dB uV/m)	Limit (dB uV/m)	Margin (dB)
*10 640.35	33.84	Peak	V	37.67	-29.95	41.56	68.23	26.67
*10 640.35	28.01	Average	V	37.67	-29.95	35.73	54.00	18.27
Above 10 700.00	Not Detected	-	-	-	-	-	-	-

802.11a (DFS) _6 Mbps

A. Low Channel (5 500 MHz)

Radiated Emissions			Ant	Correction Factors		Total	Limit	
Frequency (MHz)	Reading (dB uV)	Detect Mode	Pol.	AF (dB/m)	CL (dB)	Actual (dB uV/m)	Limit (dB uV/m)	Margin (dB)
*5 460.00	12.47	Peak	H	34.29	10.25	57.01	74.00	16.99
*5 460.00	4.03	Average	H	34.29	10.25	48.57	54.00	5.43
Frequency (MHz)	Reading (dB uV)	Detect Mode	Pol.	AF (dB/m)	Amp Gain+CL (dB)	Actual (dB uV/m)	Limit (dB uV/m)	Margin (dB)
*11 000.13	43.26	Peak	V	38.09	-27.68	53.67	74.00	20.33
*11 000.13	28.14	Average	V	38.09	-27.68	38.55	54.00	15.45
Above 11 100.00	Not Detected	-	-	-	-	-	-	-

The results shown in this test report refer only to the sample(s) tested unless otherwise stated. This test report cannot be reproduced, except in full, without prior written permission of the Company.

B. Middle Channel (5 580 MHz)

Radiated Emissions			Ant	Correction Factors		Total	Limit	
Frequency (MHz)	Reading (dB uV)	Detect Mode	Pol.	AF (dB/m)	Amp Gain+CL (dB)	Actual (dB uV/m)	Limit (dB uV/m)	Margin (dB)
*11 160.23	53.62	Peak	V	37.94	-27.78	63.78	74.00	10.22
*11 160.23	39.06	Average	V	37.94	-27.78	49.22	54.00	4.78
Above 11 200.00	Not Detected	-	-	-	-	-	-	-

C. High Channel (5 700 MHz)

Radiated Emissions			Ant	Correction Factors		Total	Limit	
Frequency (MHz)	Reading (dB uV)	Detect Mode	Pol.	AF (dB/m)	Amp Gain+CL (dB)	Actual (dB uV/m)	Limit (dB uV/m)	Margin (dB)
*11 400.18	48.23	Peak	V	37.92	-26.70	59.45	74.00	14.55
*11 400.18	34.85	Average	V	37.92	-26.70	59.45	74.00	14.55
Above 11 500.00	Not Detected	-	-	-	-	-	-	-

The results shown in this test report refer only to the sample(s) tested unless otherwise stated. This test report cannot be reproduced, except in full, without prior written permission of the Company.

ANT0+ANT1
802.11n_HT20 (Non-DFS)_MCS8

A. Low Channel (5 180 MHz)

Radiated Emissions			Ant	Correction Factors		Total	Limit	
Frequency (MHz)	Reading (dB uV)	Detect Mode	Pol.	AF (dB/m)	CL (dB)	Actual (dB uV/m)	Limit (dB uV/m)	Margin (dB)
*5 150.00	11.60	Peak	H	33.43	10.14	55.17	74.00	18.83
*5 150.00	4.38	Average	H	33.43	10.14	47.95	54.00	6.05
Frequency (MHz)	Reading (dB uV)	Detect Mode	Pol.	AF (dB/m)	Amp Gain+CL (dB)	Actual (dB uV/m)	Limit (dB uV/m)	Margin (dB)
10 360.47	45.84	Peak	V	37.58	-30.75	52.67	68.23	15.56
Above 10 400.00	Not Detected	-	-	-	-	-	-	-

B. Middle Channel (5 220 MHz)

Radiated Emissions			Ant	Correction Factors		Total	Limit	
Frequency (MHz)	Reading (dB uV)	Detect Mode	Pol.	AF (dB/m)	Amp Gain+CL (dB)	Actual (dB uV/m)	Limit (dB uV/m)	Margin (dB)
10 440.65	47.89	Peak	V	37.67	-31.04	54.52	68.23	13.71
Above 10 500.00	Not Detected	-	-	-	-	-	-	-

C. High Channel (5 240 MHz)

Radiated Emissions			Ant	Correction Factors		Total	Limit	
Frequency (MHz)	Reading (dB uV)	Detect Mode	Pol.	AF (dB/m)	Amp Gain+CL (dB)	Actual (dB uV/m)	Limit (dB uV/m)	Margin (dB)
10 480.25	48.12	Peak	V	37.61	-31.10	54.63	68.23	13.60
Above 10 600.00	Not Detected	-	-	-	-	-	-	-

The results shown in this test report refer only to the sample(s) tested unless otherwise stated. This test report cannot be reproduced, except in full, without prior written permission of the Company.

802.11n_HT20 (DFS)_MCS8

A. Low Channel (5 260 MHz)

Radiated Emissions			Ant	Correction Factors		Total	Limit	
Frequency (MHz)	Reading (dB uV)	Detect Mode	Pol.	AF (dB/m)	Amp Gain+CL (dB)	Actual (dB uV/m)	Limit (dB uV/m)	Margin (dB)
10 520.17	47.66	Peak	V	37.52	-30.89	54.29	68.23	13.94
Above 10 600.00	Not Detected	-	-	-	-	-	-	-

B. Middle Channel (5 300 MHz)

Radiated Emissions			Ant	Correction Factors		Total	Limit	
Frequency (MHz)	Reading (dB uV)	Detect Mode	Pol.	AF (dB/m)	Amp Gain+CL (dB)	Actual (dB uV/m)	Limit (dB uV/m)	Margin (dB)
*10 600.21	41.79	Peak	V	37.63	-29.90	49.52	74.00	24.48
*10 600.21	29.47	Average	V	37.63	-29.90	37.20	54.00	16.80
Above 10 700.00	Not Detected	-	-	-	-	-	-	-

The results shown in this test report refer only to the sample(s) tested unless otherwise stated. This test report cannot be reproduced, except in full, without prior written permission of the Company.

C. High Channel (5 320 MHz)

Radiated Emissions			Ant	Correction Factors		Total	Limit	
Frequency (MHz)	Reading (dB uV)	Detect Mode	Pol.	AF (dB/m)	CL (dB)	Actual (dB uV/m)	Limit (dB uV/m)	Margin (dB)
*5 350.00	10.25	Peak	H	33.75	10.09	54.09	74.00	19.91
*5 350.00	4.18	Average	H	33.75	10.09	48.02	54.00	5.98
Frequency (MHz)	Reading (dB uV)	Detect Mode	Pol.	AF (dB/m)	Amp Gain+CL (dB)	Actual (dB uV/m)	Limit (dB uV/m)	Margin (dB)
*10 640.35	37.68	Peak	V	37.67	-29.95	45.40	68.23	22.83
*10 640.35	26.25	Average	V	37.67	-29.95	33.97	54.00	20.03
Above 10 700.00	Not Detected	-	-	-	-	-	-	-

802.11n_HT20 (DFS)_MCS8

A. Low Channel (5 500 MHz)

Radiated Emissions			Ant	Correction Factors		Total	Limit	
Frequency (MHz)	Reading (dB uV)	Detect Mode	Pol.	AF (dB/m)	CL (dB)	Actual (dB uV/m)	Limit (dB uV/m)	Margin (dB)
*5 460.00	13.18	Peak	H	34.29	10.25	57.72	74.00	16.28
*5 460.00	3.62	Average	H	34.29	10.25	48.16	54.00	5.84
Frequency (MHz)	Reading (dB uV)	Detect Mode	Pol.	AF (dB/m)	Amp Gain+CL (dB)	Actual (dB uV/m)	Limit (dB uV/m)	Margin (dB)
*11 000.11	41.56	Peak	V	38.09	-27.68	51.97	74.00	22.03
*11 000.11	26.76	Average	V	38.09	-27.68	37.17	54.00	16.83
Above 11 100.00	Not Detected	-	-	-	-	-	-	-

The results shown in this test report refer only to the sample(s) tested unless otherwise stated. This test report cannot be reproduced, except in full, without prior written permission of the Company.

B. Middle Channel (5 580 MHz)

Radiated Emissions			Ant	Correction Factors		Total	Limit	
Frequency (MHz)	Reading (dB uV)	Detect Mode	Pol.	AF (dB/m)	Amp Gain+CL (dB)	Actual (dB uV/m)	Limit (dB uV/m)	Margin (dB)
*11 159.81	51.10	Peak	V	37.94	-27.78	61.26	74.00	12.74
*11 159.81	38.47	Average	V	37.94	-27.78	48.63	54.00	5.37
Above 11 200.00	Not Detected	-	-	-	-	-	-	-

C. High Channel (5 700 MHz)

Radiated Emissions			Ant	Correction Factors		Total	Limit	
Frequency (MHz)	Reading (dB uV)	Detect Mode	Pol.	AF (dB/m)	Amp Gain+CL (dB)	Actual (dB uV/m)	Limit (dB uV/m)	Margin (dB)
*11 400.91	46.11	Peak	V	37.93	-26.70	57.34	74.00	16.66
*11 400.91	32.83	Average	V	37.93	-26.70	44.06	54.00	9.94
Above 11 500.00	Not Detected	-	-	-	-	-	-	-

The results shown in this test report refer only to the sample(s) tested unless otherwise stated. This test report cannot be reproduced, except in full, without prior written permission of the Company.

802.11n_HT40 (Non-DFS) _MCS8
A. Low Channel (5 190 MHz)

Radiated Emissions			Ant	Correction Factors		Total	Limit	
Frequency (MHz)	Reading (dB uV)	Detect Mode	Pol.	AF (dB/m)	CL (dB)	Actual (dB uV/m)	Limit (dB uV/m)	Margin (dB)
*5 150.00	11.59	Peak	H	33.43	10.14	55.16	74.00	18.84
*5 150.00	3.96	Average	H	33.43	10.14	47.53	54.00	6.47
Frequency (MHz)	Reading (dB uV)	Detect Mode	Pol.	AF (dB/m)	Amp Gain+CL (dB)	Actual (dB uV/m)	Limit (dB uV/m)	Margin (dB)
10 379.39	43.24	Peak	V	37.54	-30.86	49.92	68.23	18.31
Above 10 400.00	Not Detected	-	-	-	-	-	-	-

B. High Channel (5 230 MHz)

Frequency (MHz)	Reading (dB uV)	Detect Mode	Pol.	AF (dB/m)	Amp Gain+CL (dB)	Actual (dB uV/m)	Limit (dB uV/m)	Margin (dB)
10 459.03	45.03	Peak	V	37.62	-31.07	51.58	68.23	16.65
Above 10 500.00	Not Detected	-	-	-	-	-	-	-

The results shown in this test report refer only to the sample(s) tested unless otherwise stated. This test report cannot be reproduced, except in full, without prior written permission of the Company.

802. 11n_HT40 (DFS)_MCS8
A. Low Channel (5 270 MHz)

Radiated Emissions			Ant	Correction Factors		Total	Limit	
Frequency (MHz)	Reading (dB uV)	Detect Mode	Pol.	AF (dB/m)	Amp Gain+CL (dB)	Actual (dB uV/m)	Limit (dB uV/m)	Margin (dB)
10 540.07	43.99	Peak	V	37.54	-30.64	50.89	68.23	17.34
Above 10 600.00	Not Detected	-	-	-	-	-	-	-

B. High Channel (5 310 MHz)

Radiated Emissions			Ant	Correction Factors		Total	Limit	
Frequency (MHz)	Reading (dB uV)	Detect Mode	Pol.	AF (dB/m)	CL (dB)	Actual (dB uV/m)	Limit (dB uV/m)	Margin (dB)
*5 350.00	11.35	Peak	H	33.75	10.09	55.19	74.00	18.81
*5 350.00	3.99	Average	H	33.75	10.09	47.83	54.00	6.17
Frequency (MHz)	Reading (dB uV)	Detect Mode	Pol.	AF (dB/m)	Amp Gain+CL (dB)	Actual (dB uV/m)	Limit (dB uV/m)	Margin (dB)
*10 620.14	39.47	Peak	V	37.71	-29.93	47.25	74.00	26.75
*10 620.14	28.06	Average	V	37.71	-29.93	35.84	54.00	18.16
Above 10 700.00	Not Detected	-	-	-	-	-	-	-

The results shown in this test report refer only to the sample(s) tested unless otherwise stated. This test report cannot be reproduced, except in full, without prior written permission of the Company.

802. 11n_HT40 (DFS)_MCS8
A. Low Channel (5 510 MHz)

Radiated Emissions			Ant	Correction Factors		Total	Limit	
Frequency (MHz)	Reading (dB uV)	Detect Mode	Pol.	AF (dB/m)	CL (dB)	Actual (dB uV/m)	Limit (dB uV/m)	Margin (dB)
*5 460.00	12.14	Peak	H	34.29	10.25	56.68	74.00	17.32
*5 460.00	3.88	Average	H	34.29	10.25	48.42	54.00	5.58
Frequency (MHz)	Reading (dB uV)	Detect Mode	Pol.	AF (dB/m)	Amp Gain+CL (dB)	Actual (dB uV/m)	Limit (dB uV/m)	Margin (dB)
*11 020.59	41.22	Peak	V	38.15	-27.72	51.65	74.00	22.35
*11 020.59	29.02	Average	V	38.15	-27.72	39.45	54.00	14.55
Above 11 100.00	Not Detected	-	-	-	-	-	-	-

B. Middle Channel (5 550 MHz)

Radiated Emissions			Ant	Correction Factors		Total	Limit	
Frequency (MHz)	Reading (dB uV)	Detect Mode	Pol.	AF (dB/m)	Amp Gain+CL (dB)	Actual (dB uV/m)	Limit (dB uV/m)	Margin (dB)
*11 100.10	46.27	Peak	V	38.01	-27.87	56.41	74.00	17.59
*11 100.10	33.65	Average	V	38.01	-27.87	43.79	54.00	10.21
Above 11 200.00	Not Detected	-	-	-	-	-	-	-

The results shown in this test report refer only to the sample(s) tested unless otherwise stated. This test report cannot be reproduced, except in full, without prior written permission of the Company.

C. High Channel (5 670 MHz)

Radiated Emissions			Ant	Correction Factors		Total	Limit	
Frequency (MHz)	Reading (dB uV)	Detect Mode	Pol.	AF (dB/m)	Amp Gain+CL (dB)	Actual (dB uV/m)	Limit (dB uV/m)	Margin (dB)
*11 340.01	41.64	Peak	V	38.11	-26.99	52.76	74.00	21.24
*11 340.01	29.25	Average	V	38.11	-26.99	40.37	54.00	13.63
Above 11 500.00	Not Detected	-	-	-	-	-	-	-

Remark:

1. "*" means the restricted band.
2. Radiated emissions measured in frequency above 1 000 MHz were made with an instrument using Peak / average detector mode if frequency was in restricted band. Otherwise the frequency was in outside of restricted band, only peak detector should be used.
3. Average test would be performed if the peak result was greater than the average limit and frequency was in the restricted band.
4. If frequency was outside of restricted band, the calculation method for peak limit is same as below:
 $68.23 \text{ dB}\mu\text{V/m} = \text{EIRP} - 20 \log(d) + 104.77 = -27 - 20 \log(3) + 104.77$
 *distance: 3 m, *EIRP: -27 dB m/MHz

The results shown in this test report refer only to the sample(s) tested unless otherwise stated. This test report cannot be reproduced, except in full, without prior written permission of the Company.

3. 26 dB bandwidth and 99 % occupied bandwidth

3.1. Test setup



3.2. Limit

None; for reporting purpose only

3.3. Test procedure

All data rates and modes were investigated for this test. The full data for the worst case data rate are reported in this section.

3.3.1. 26 dB Bandwidth

1. This measurement settings are specified in section D of KDB 789033_v01r03.
2. Set RBW: approximately 1% of the emission bandwidth.
3. Set the VBW > RBW.
4. Detector = Peak
5. Trace mode = max hold.
6. Measure the maximum width of the emission that is 26 dB down from the peak of the emission. Compare this with the RBW setting of the analyzer. Readjust RBW and repeat measurement as needed until the RBW/EBW ratio is approximately 1 %

Note: The automatic bandwidth measurement capability of a spectrum analyzer may be employed if it implements the functionality described above.

3.3.2. 99% bandwidth

1. Set the spectrum analyzer as SPAN = 2 or 3 times necessary bandwidth, RBW = approximately 1 % of the SPAN, VBW is set to 3 times RBW, Detector = Sample, Trace mode = max hold.
2. Measure lowest and highest frequencies are placed in a running sum until 0.5 % and 99.5 % of the total is reached.
3. Record the SPAN between the lowest and the highest frequencies for the 99 % occupied bandwidth.
4. Repeat until all the test channels are investigated.

The results shown in this test report refer only to the sample(s) tested unless otherwise stated. This test report cannot be reproduced, except in full, without prior written permission of the Company.

3.4. Test result

Ambient temperature : (24 ± 2) °C
 Relative humidity : 49 % R.H.

ANT0

802.11a

Operating mode	Frequency(MHz)	26 dB bandwidth(MHz)	99% bandwidth(MHz)
Non - DFS	5 180	27.76	16.63
	5 220	28.45	16.57
	5 240	27.83	16.56
DFS	5 260	29.69	16.58
	5 300	26.23	16.55
	5 320	26.63	16.55
DFS	5 500	24.59	16.49
	5 580	21.95	16.49
	5 700	22.64	16.50

802.11n_HT20

Operating mode	Frequency(MHz)	26 dB bandwidth(MHz)	99% bandwidth(MHz)
Non - DFS	5 180	29.71	17.80
	5 220	29.64	17.78
	5 240	29.35	17.82
DFS	5 260	29.36	17.79
	5 300	29.25	17.73
	5 320	29.13	17.77
DFS	5 500	25.51	17.71
	5 580	22.94	17.71
	5 700	26.58	17.72

802.11n_HT40

Operating mode	Frequency(MHz)	26 dB bandwidth(MHz)	99% bandwidth(MHz)
Non - DFS	5 190	49.86	36.16
	5 230	50.00	36.17
DFS	5 270	48.08	36.13
	5 310	45.30	36.13
	5 510	44.74	36.16
	5 550	43.78	36.16
	5 670	45.17	36.14

The results shown in this test report refer only to the sample(s) tested unless otherwise stated. This test report cannot be reproduced, except in full, without prior written permission of the Company.

ANT1
802.11a

Operating mode	Frequency(MHz)	26 dB bandwidth(MHz)	99% bandwidth(MHz)
Non - DFS	5 180	29.13	16.59
	5 220	27.78	16.57
	5 240	27.98	16.57
DFS	5 260	29.08	16.58
	5 300	26.96	16.55
	5 320	29.98	16.53
DFS	5 500	26.10	16.51
	5 580	23.92	16.49
	5 700	23.74	16.51

802.11n_HT20

Operating mode	Frequency(MHz)	26 dB bandwidth(MHz)	99% bandwidth(MHz)
Non - DFS	5 180	29.96	17.81
	5 220	29.85	17.82
	5 240	29.99	17.78
DFS	5 260	29.70	17.79
	5 300	29.24	17.77
	5 320	29.87	17.77
DFS	5 500	27.47	17.72
	5 580	25.67	17.71
	5 700	25.57	17.72

802.11n_HT40

Operating mode	Frequency(MHz)	26 dB bandwidth(MHz)	99% bandwidth(MHz)
Non - DFS	5 190	50.00	36.16
	5 230	49.60	36.20
DFS	5 270	49.88	36.19
	5 310	49.12	36.16
	5 510	47.90	36.15
	5 550	47.58	36.15
	5 670	46.30	36.12

The results shown in this test report refer only to the sample(s) tested unless otherwise stated. This test report cannot be reproduced, except in full, without prior written permission of the Company.

26 dB Bandwidth

ANT0

802.11a (Non-DFS)

Low Channel (5 180 MHz)



Middle Channel (5 220 MHz)



The results shown in this test report refer only to the sample(s) tested unless otherwise stated. This test report cannot be reproduced, except in full, without prior written permission of the Company.

H7igh Channel (5 240 MHz)

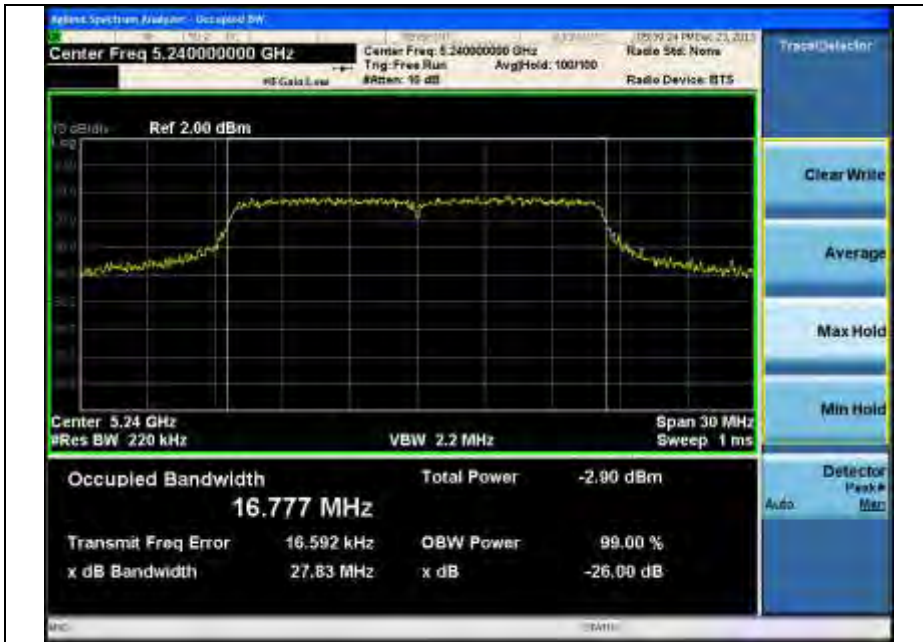

802.11a (DFS)

Low Channel (5 260 MHz)



The results shown in this test report refer only to the sample(s) tested unless otherwise stated. This test report cannot be reproduced, except in full, without prior written permission of the Company.

Middle Channel (5 300 MHz)

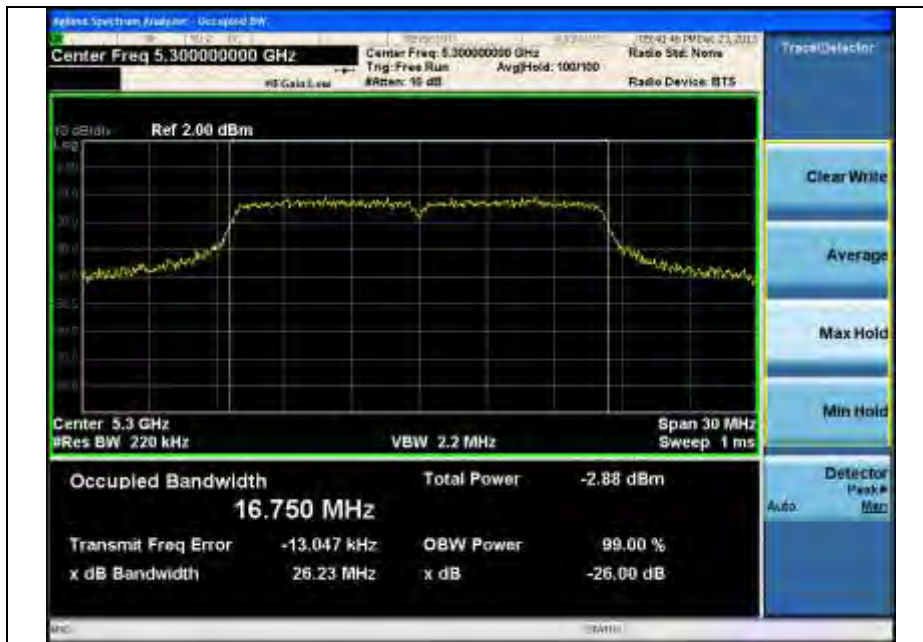

High Channel (5 320 MHz)

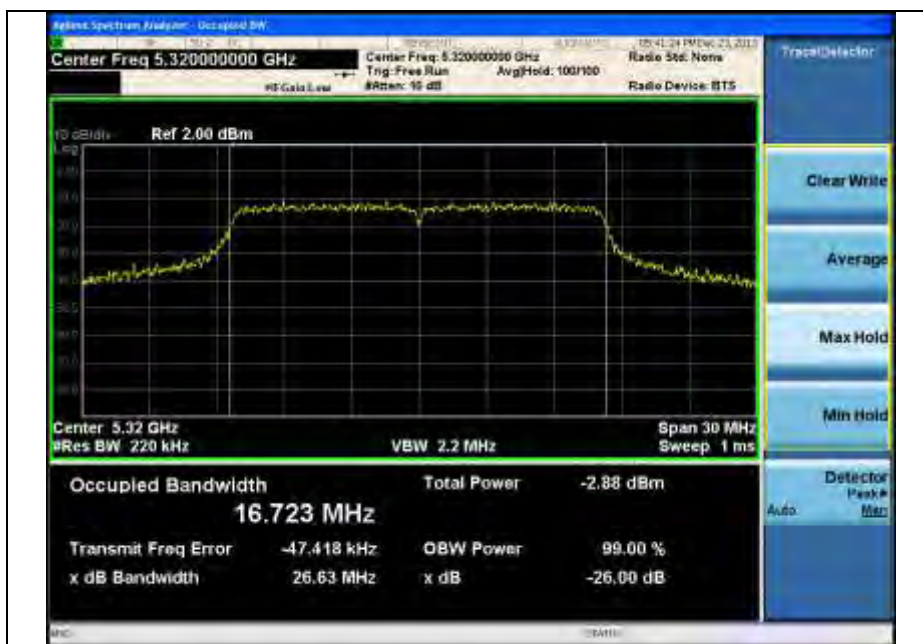

The results shown in this test report refer only to the sample(s) tested unless otherwise stated. This test report cannot be reproduced, except in full, without prior written permission of the Company.

802.11a (DFS)

Low Channel (5 500 MHz)



Middle Channel (5 580 MHz)



The results shown in this test report refer only to the sample(s) tested unless otherwise stated. This test report cannot be reproduced, except in full, without prior written permission of the Company.

High Channel (5 700 MHz)



The results shown in this test report refer only to the sample(s) tested unless otherwise stated. This test report cannot be reproduced, except in full, without prior written permission of the Company.

802.11n_HT20 (Non-DFS)

Low Channel (5 180 MHz)



Middle Channel (5 220 MHz)



The results shown in this test report refer only to the sample(s) tested unless otherwise stated. This test report cannot be reproduced, except in full, without prior written permission of the Company.

High Channel (5 240 MHz)



802.11n_HT20 (DFS)

Low Channel (5 260 MHz)



The results shown in this test report refer only to the sample(s) tested unless otherwise stated. This test report cannot be reproduced, except in full, without prior written permission of the Company.

Middle Channel (5 300 MHz)



High Channel (5 320 MHz)



The results shown in this test report refer only to the sample(s) tested unless otherwise stated. This test report cannot be reproduced, except in full, without prior written permission of the Company.

802.11n_HT20 (DFS)

Low Channel (5 500 MHz)

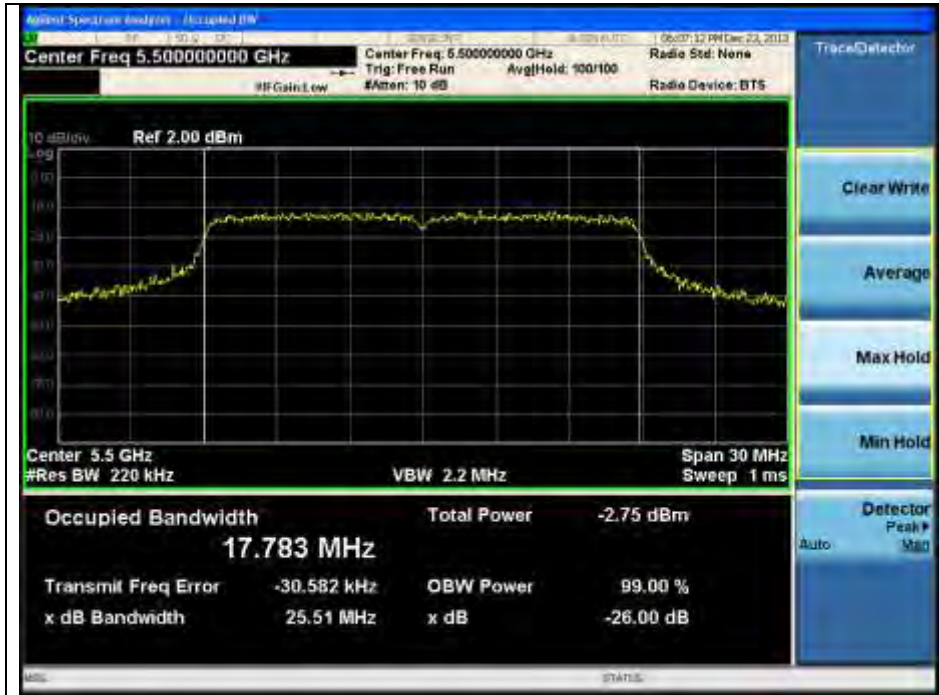

Middle Channel (5 580 MHz)

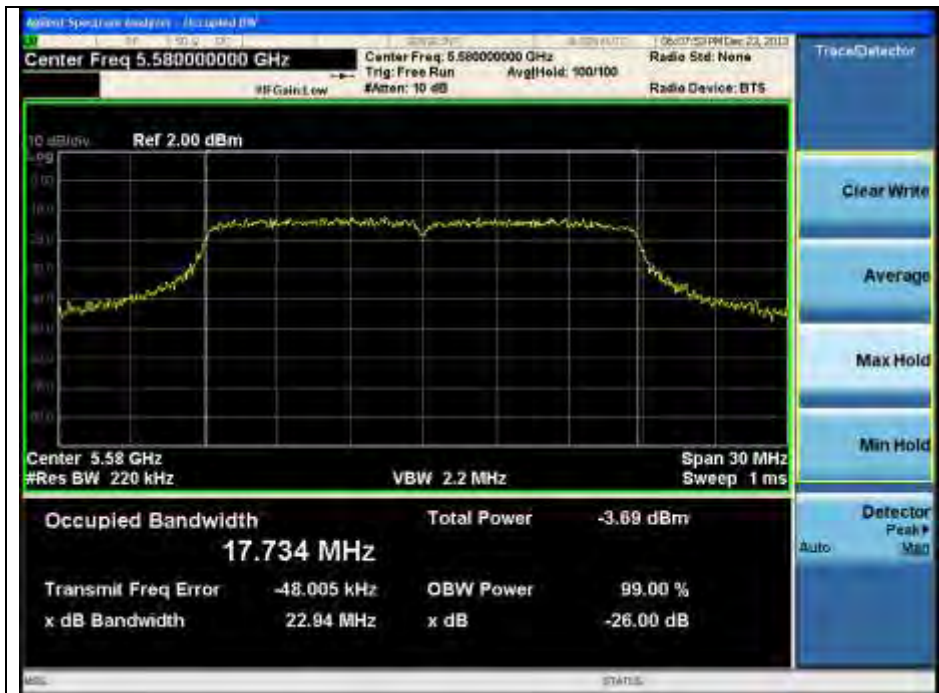

The results shown in this test report refer only to the sample(s) tested unless otherwise stated. This test report cannot be reproduced, except in full, without prior written permission of the Company.

High Channel (5 700 MHz)



The results shown in this test report refer only to the sample(s) tested unless otherwise stated. This test report cannot be reproduced, except in full, without prior written permission of the Company.

802.11n_HT40 (Non-DFS)

Low Channel (5 190 MHz)



High Channel (5 230 MHz)



The results shown in this test report refer only to the sample(s) tested unless otherwise stated. This test report cannot be reproduced, except in full, without prior written permission of the Company.

802.11n_HT40 (DFS)

Low Channel (5 270 MHz)



High Channel (5 310 MHz)



The results shown in this test report refer only to the sample(s) tested unless otherwise stated. This test report cannot be reproduced, except in full, without prior written permission of the Company.

802.11n_HT40 (DFS)

Low Channel (5 510 MHz)



Low Channel (5 550 MHz)



The results shown in this test report refer only to the sample(s) tested unless otherwise stated. This test report cannot be reproduced, except in full, without prior written permission of the Company.

High Channel (5 670 MHz)



The results shown in this test report refer only to the sample(s) tested unless otherwise stated. This test report cannot be reproduced, except in full, without prior written permission of the Company.

ANT1

802.11a (Non-DFS)

Low Channel (5 180 MHz)



Middle Channel (5 220 MHz)

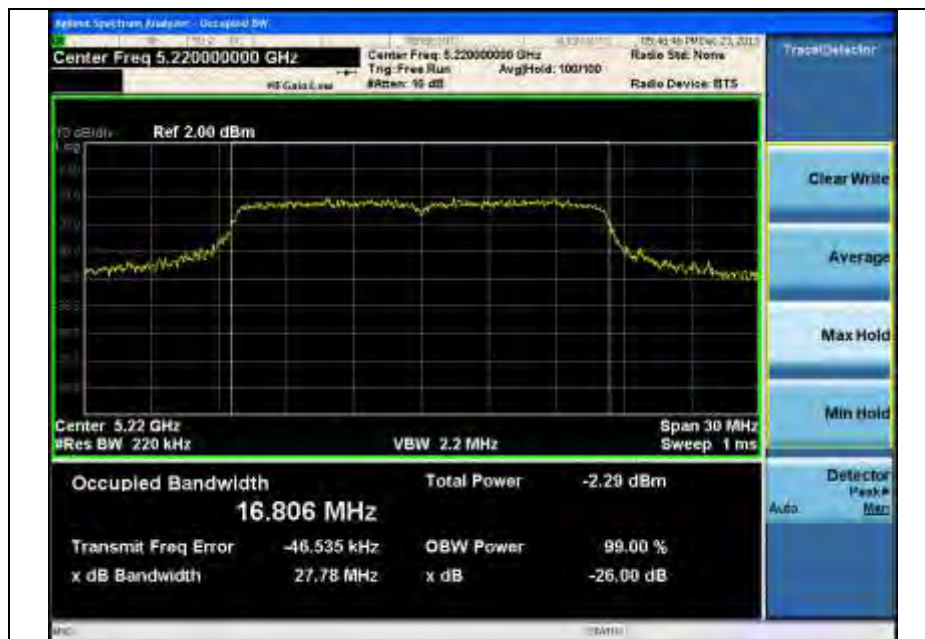

The results shown in this test report refer only to the sample(s) tested unless otherwise stated. This test report cannot be reproduced, except in full, without prior written permission of the Company.

High Channel (5 240 MHz)



802.11a (DFS)

Low Channel (5 260 MHz)



The results shown in this test report refer only to the sample(s) tested unless otherwise stated. This test report cannot be reproduced, except in full, without prior written permission of the Company.

Middle Channel (5 300 MHz)

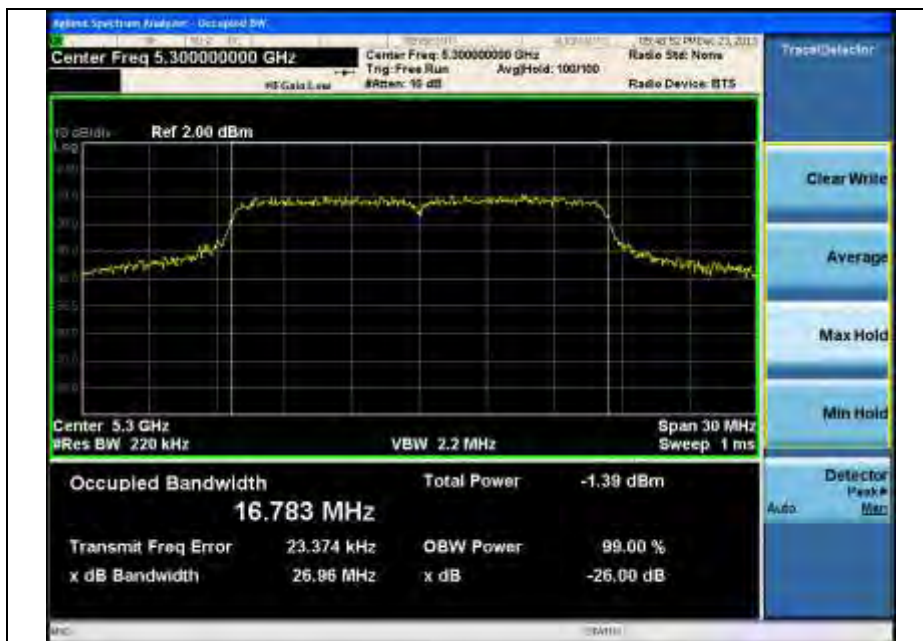

High Channel (5 320 MHz)

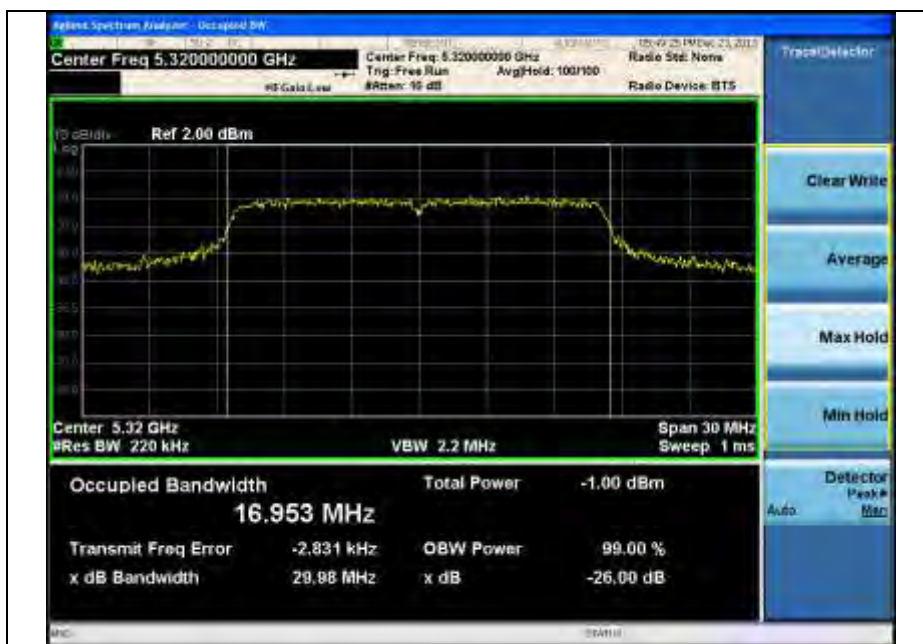

The results shown in this test report refer only to the sample(s) tested unless otherwise stated. This test report cannot be reproduced, except in full, without prior written permission of the Company.

802.11a (DFS)

Low Channel (5 500 MHz)



Middle Channel (5 580 MHz)



The results shown in this test report refer only to the sample(s) tested unless otherwise stated. This test report cannot be reproduced, except in full, without prior written permission of the Company.

High Channel (5 700 MHz)



The results shown in this test report refer only to the sample(s) tested unless otherwise stated. This test report cannot be reproduced, except in full, without prior written permission of the Company.

802.11n_HT20 (Non-DFS)

Low Channel (5 180 MHz)

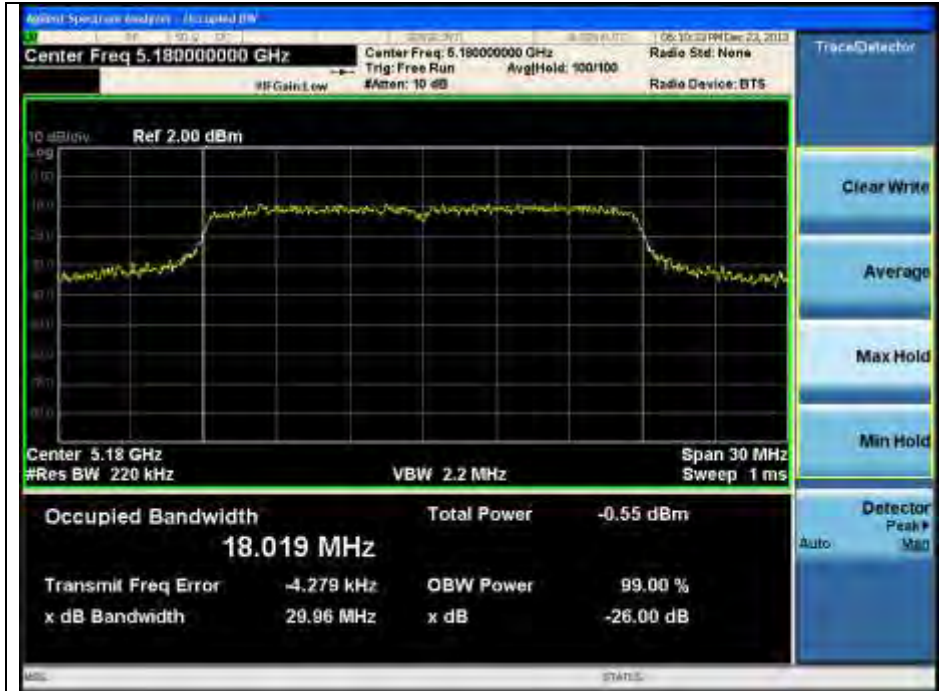

Middle Channel (5 220 MHz)

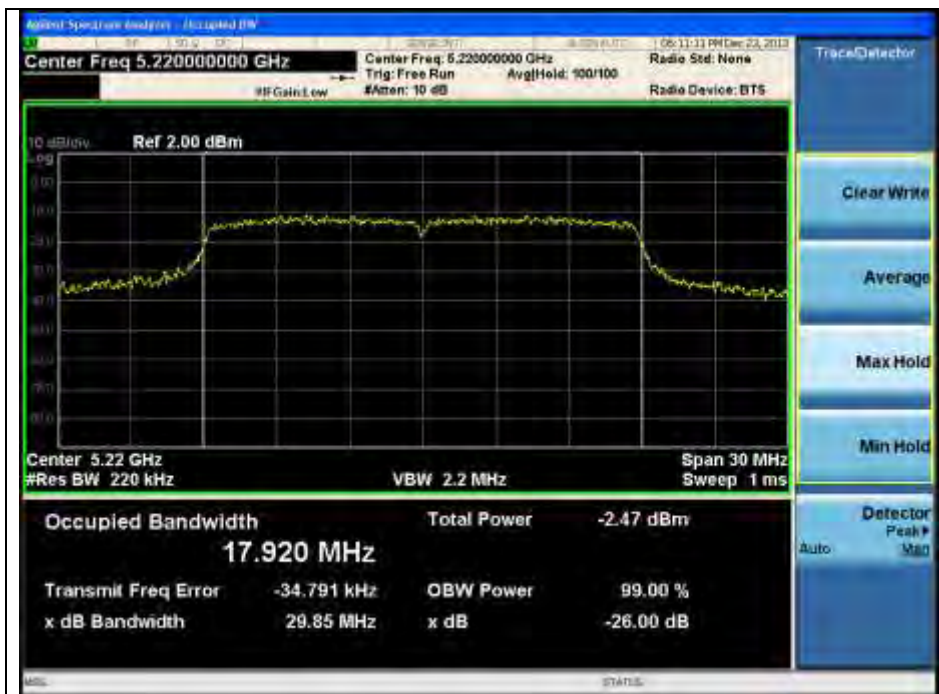

The results shown in this test report refer only to the sample(s) tested unless otherwise stated. This test report cannot be reproduced, except in full, without prior written permission of the Company.

High Channel (5 240 MHz)



802.11n_HT20 (DFS)

Low Channel (5 260 MHz)



The results shown in this test report refer only to the sample(s) tested unless otherwise stated. This test report cannot be reproduced, except in full, without prior written permission of the Company.

Middle Channel (5 300 MHz)



High Channel (5 320 MHz)



The results shown in this test report refer only to the sample(s) tested unless otherwise stated. This test report cannot be reproduced, except in full, without prior written permission of the Company.

802.11n_HT20 (DFS)

Low Channel (5 500 MHz)



Middle Channel (5 580 MHz)



The results shown in this test report refer only to the sample(s) tested unless otherwise stated. This test report cannot be reproduced, except in full, without prior written permission of the Company.

High Channel (5 700 MHz)



The results shown in this test report refer only to the sample(s) tested unless otherwise stated. This test report cannot be reproduced, except in full, without prior written permission of the Company.

802.11n_HT40 (Non-DFS)

Low Channel (5 190 MHz)



High Channel (5 230 MHz)



The results shown in this test report refer only to the sample(s) tested unless otherwise stated. This test report cannot be reproduced, except in full, without prior written permission of the Company.

802.11n_HT40 (DFS)

Low Channel (5 270 MHz)



High Channel (5 310 MHz)



The results shown in this test report refer only to the sample(s) tested unless otherwise stated. This test report cannot be reproduced, except in full, without prior written permission of the Company.

802.11n_HT40 (DFS)

Low Channel (5 510 MHz)



Low Channel (5 550 MHz)



The results shown in this test report refer only to the sample(s) tested unless otherwise stated. This test report cannot be reproduced, except in full, without prior written permission of the Company.

High Channel (5 670 MHz)



The results shown in this test report refer only to the sample(s) tested unless otherwise stated. This test report cannot be reproduced, except in full, without prior written permission of the Company.

99% Bandwidth
ANT0
802.11a (Non-DFS)
 Low Channel (5 180 MHz)



Middle Channel (5 220 MHz)



The results shown in this test report refer only to the sample(s) tested unless otherwise stated. This test report cannot be reproduced, except in full, without prior written permission of the Company.

High Channel (5 240 MHz)



802.11a (DFS)

Low Channel (5 260 MHz)

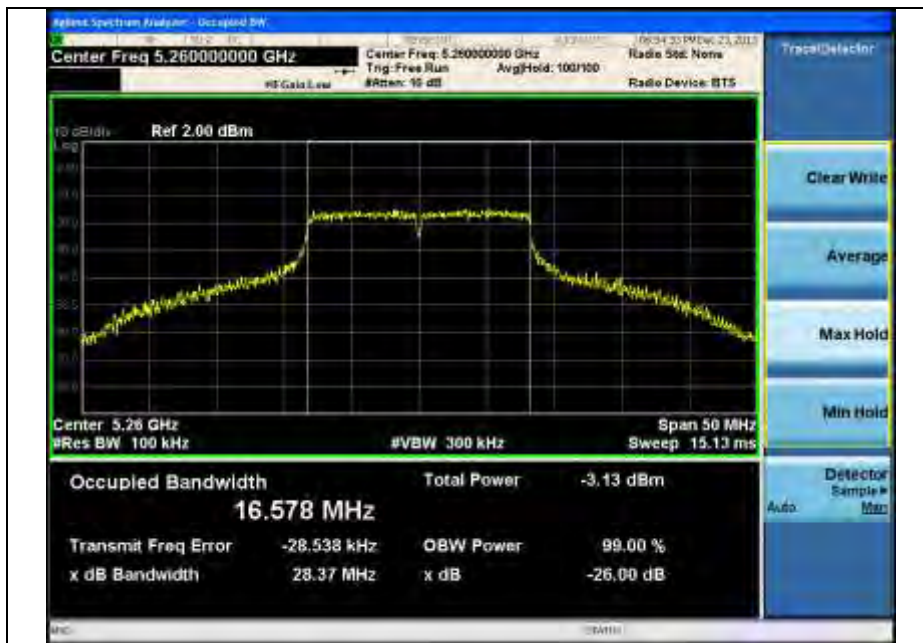

The results shown in this test report refer only to the sample(s) tested unless otherwise stated. This test report cannot be reproduced, except in full, without prior written permission of the Company.

Middle Channel (5 300 MHz)

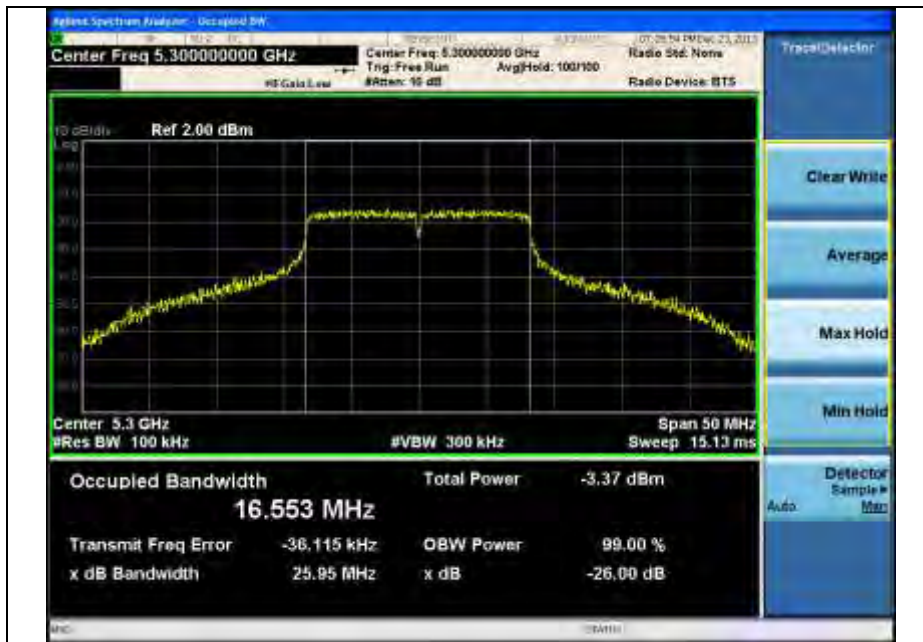

High Channel (5 320 MHz)



The results shown in this test report refer only to the sample(s) tested unless otherwise stated. This test report cannot be reproduced, except in full, without prior written permission of the Company.

802.11a (DFS)

Low Channel (5 500 MHz)

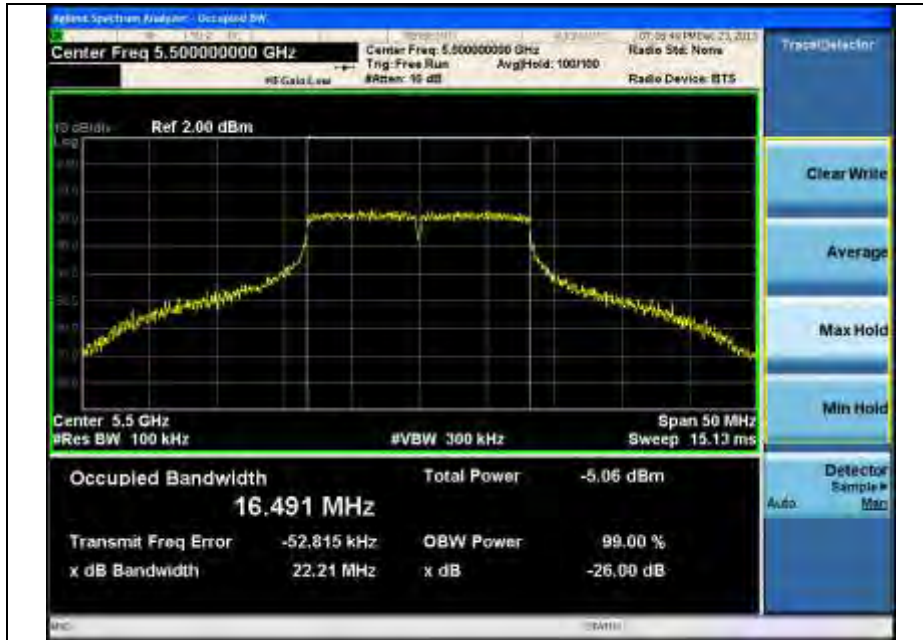

Middle Channel (5 580 MHz)

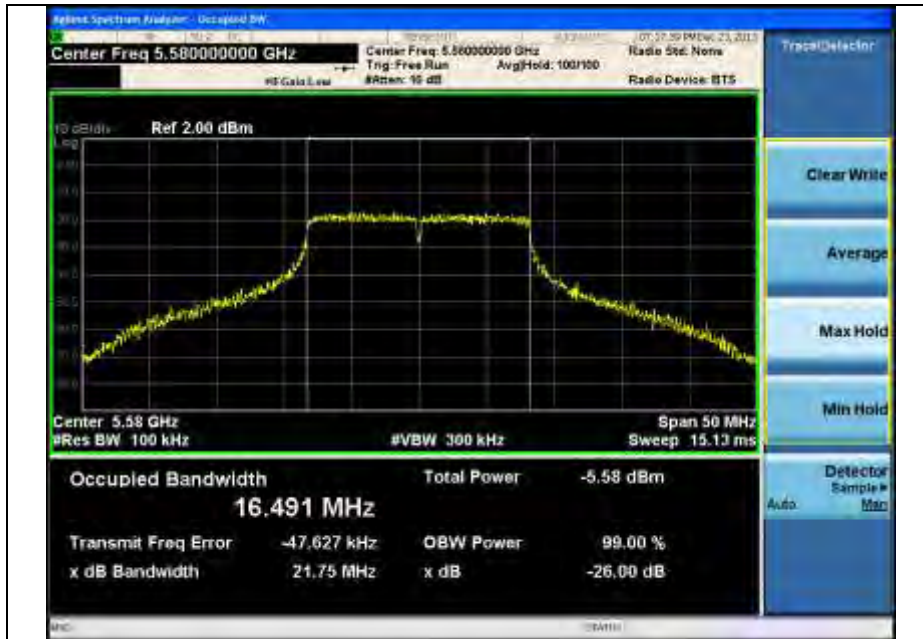

The results shown in this test report refer only to the sample(s) tested unless otherwise stated. This test report cannot be reproduced, except in full, without prior written permission of the Company.

High Channel (5 700 MHz)

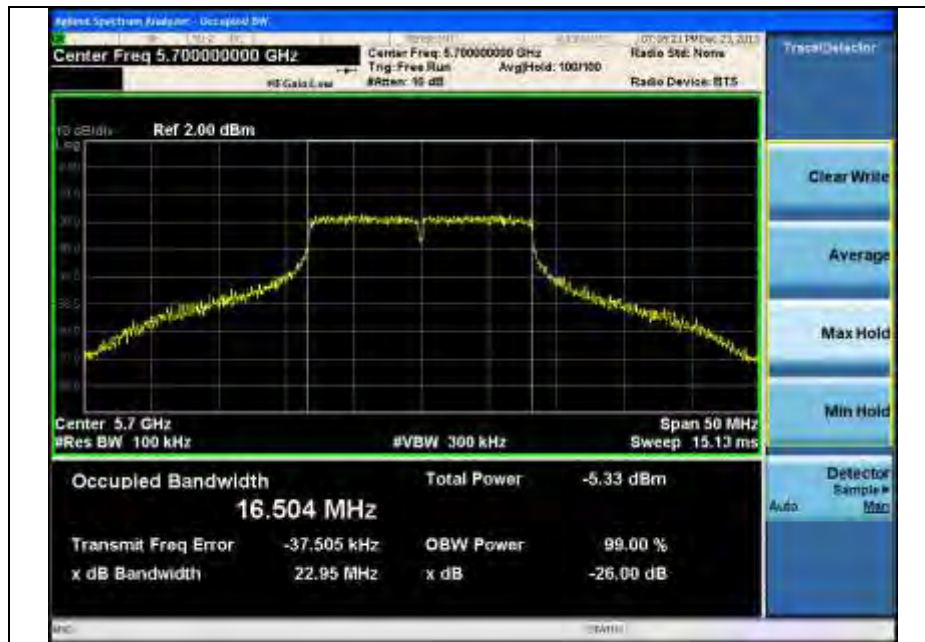

The results shown in this test report refer only to the sample(s) tested unless otherwise stated. This test report cannot be reproduced, except in full, without prior written permission of the Company.

802.11n_HT20 (Non-DFS)

Low Channel (5 180 MHz)

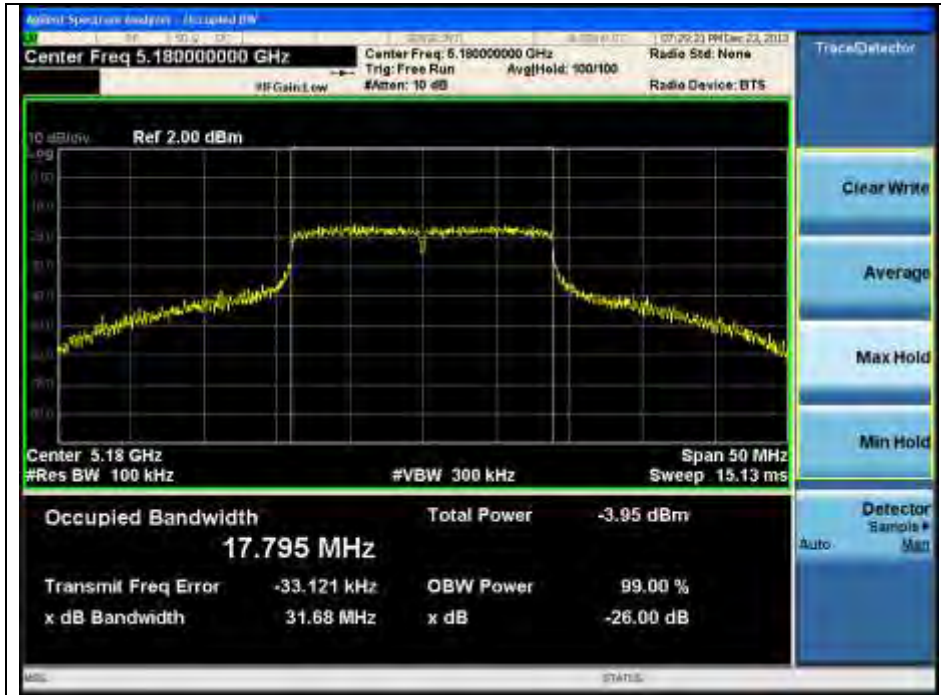

Middle Channel (5 220 MHz)



The results shown in this test report refer only to the sample(s) tested unless otherwise stated. This test report cannot be reproduced, except in full, without prior written permission of the Company.

High Channel (5 240 MHz)

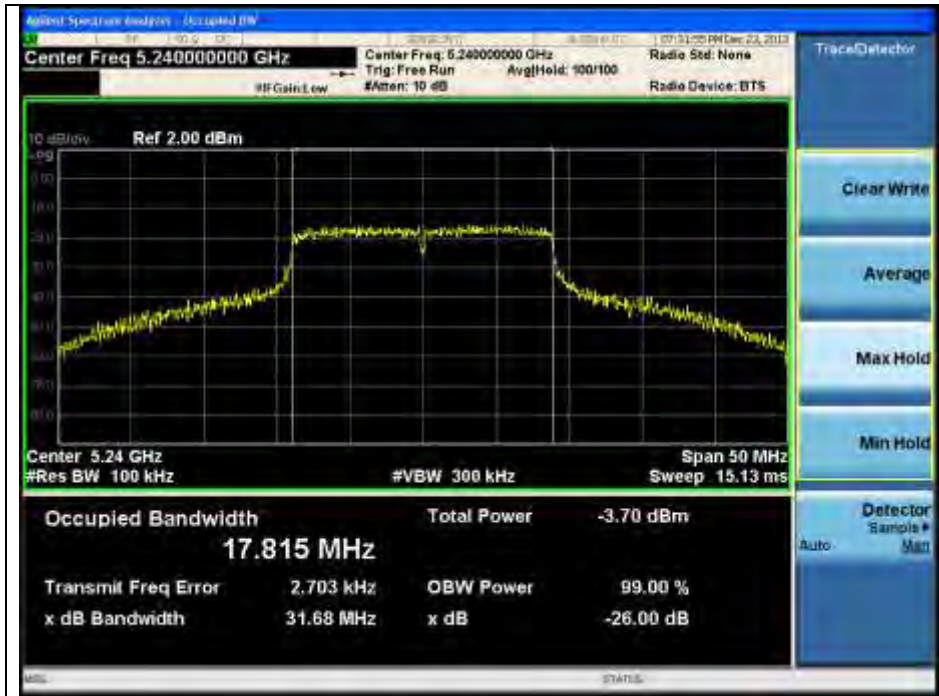

802.11n_HT20 (DFS)

Low Channel (5 260 MHz)



The results shown in this test report refer only to the sample(s) tested unless otherwise stated. This test report cannot be reproduced, except in full, without prior written permission of the Company.

Middle Channel (5 300 MHz)

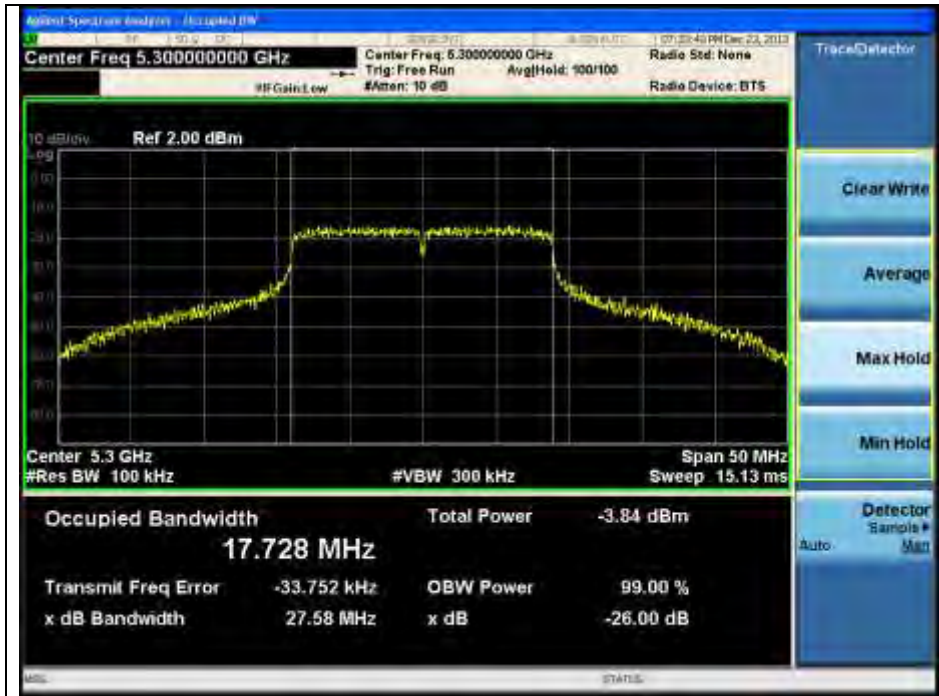

High Channel (5 320 MHz)



The results shown in this test report refer only to the sample(s) tested unless otherwise stated. This test report cannot be reproduced, except in full, without prior written permission of the Company.

802.11n_HT20 (DFS)

Low Channel (5 500 MHz)

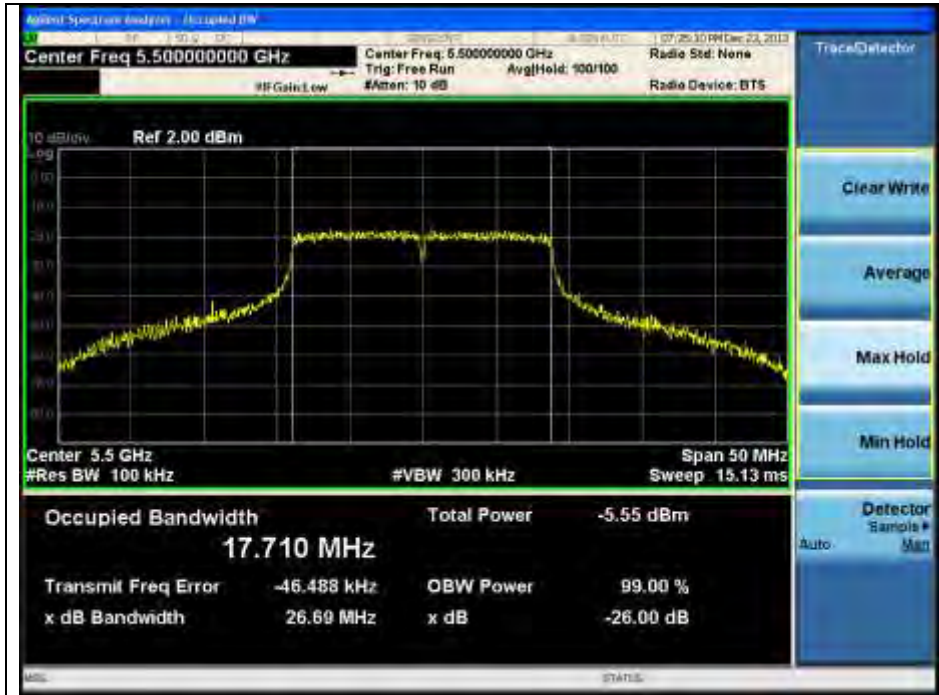

Middle Channel (5 580 MHz)



The results shown in this test report refer only to the sample(s) tested unless otherwise stated. This test report cannot be reproduced, except in full, without prior written permission of the Company.

High Channel (5 700 MHz)



The results shown in this test report refer only to the sample(s) tested unless otherwise stated. This test report cannot be reproduced, except in full, without prior written permission of the Company.

802.11n_HT40 (Non-DFS)

Low Channel (5 190 MHz)



High Channel (5 230 MHz)



The results shown in this test report refer only to the sample(s) tested unless otherwise stated. This test report cannot be reproduced, except in full, without prior written permission of the Company.

802.11n_HT40 (DFS)

Low Channel (5 270 MHz)



High Channel (5 310 MHz)



The results shown in this test report refer only to the sample(s) tested unless otherwise stated. This test report cannot be reproduced, except in full, without prior written permission of the Company.

802.11n_HT40 (DFS)

Low Channel (5 510 MHz)



Low Channel (5 550 MHz)



The results shown in this test report refer only to the sample(s) tested unless otherwise stated. This test report cannot be reproduced, except in full, without prior written permission of the Company.

High Channel (5 670 MHz)



The results shown in this test report refer only to the sample(s) tested unless otherwise stated. This test report cannot be reproduced, except in full, without prior written permission of the Company.

ANT1

802.11a (Non-DFS)

Low Channel (5 180 MHz)

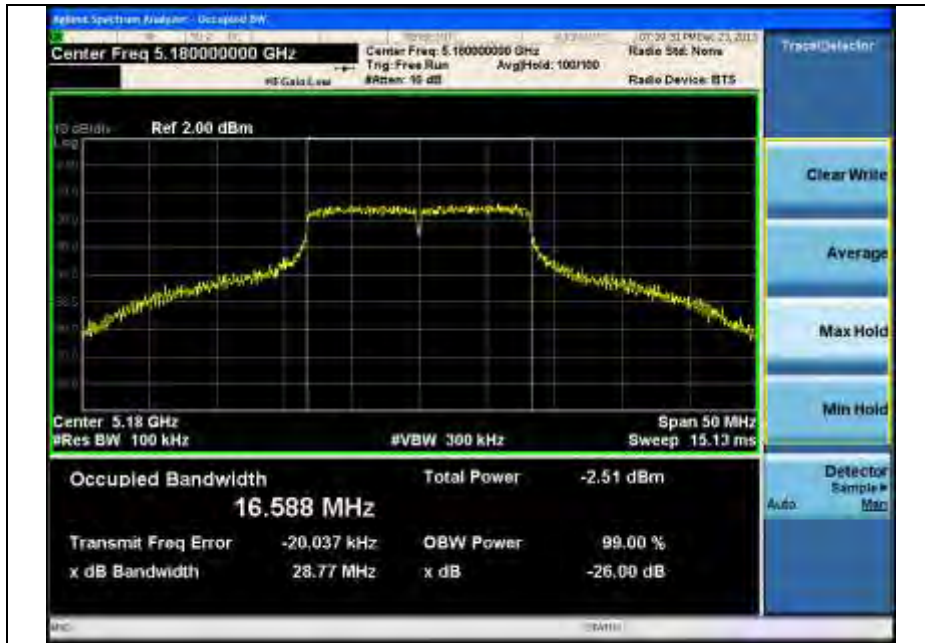

Middle Channel (5 220 MHz)

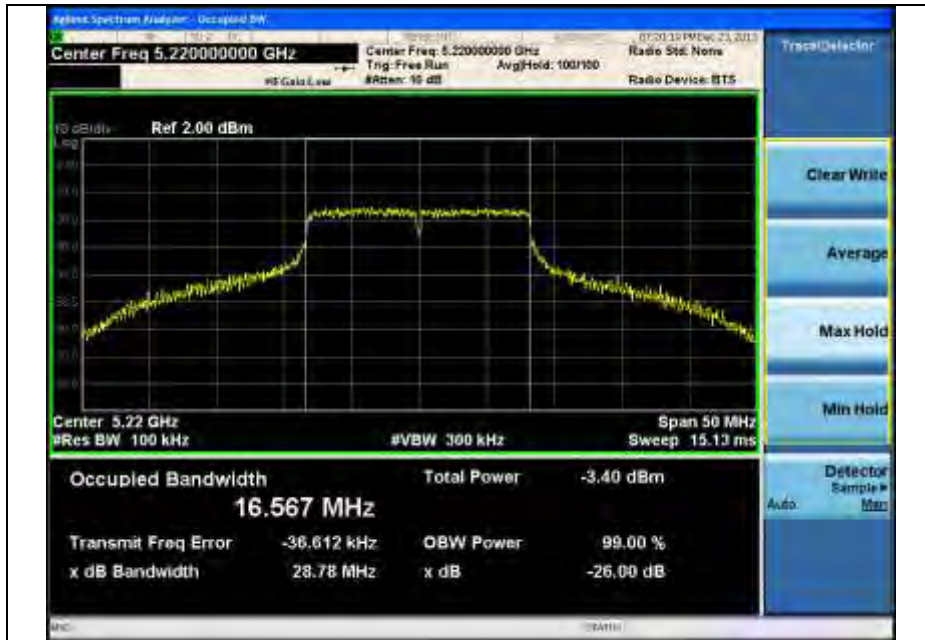

The results shown in this test report refer only to the sample(s) tested unless otherwise stated. This test report cannot be reproduced, except in full, without prior written permission of the Company.

High Channel (5 240 MHz)



802.11a (DFS)

Low Channel (5 260 MHz)



The results shown in this test report refer only to the sample(s) tested unless otherwise stated. This test report cannot be reproduced, except in full, without prior written permission of the Company.

Middle Channel (5 300 MHz)

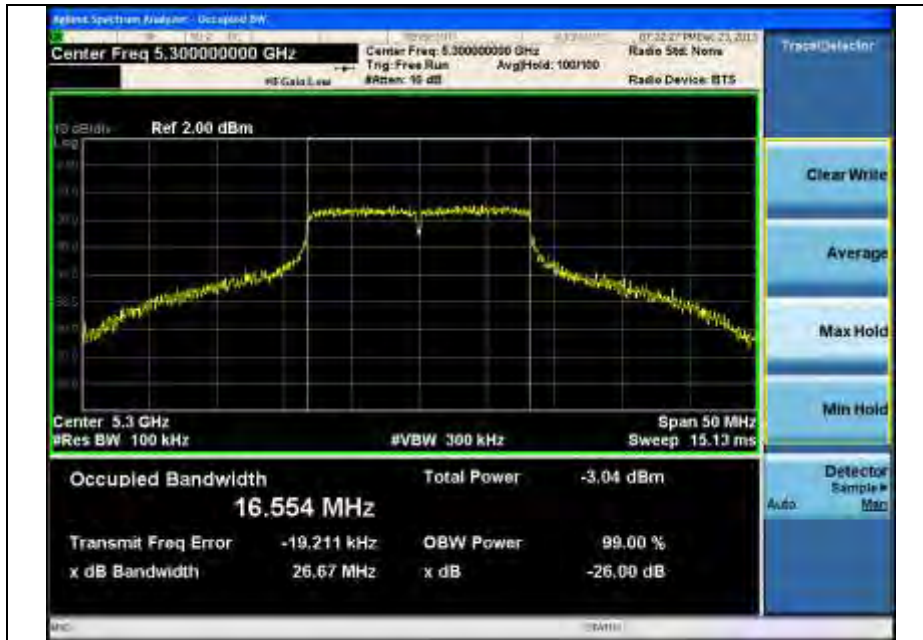

High Channel (5 320 MHz)

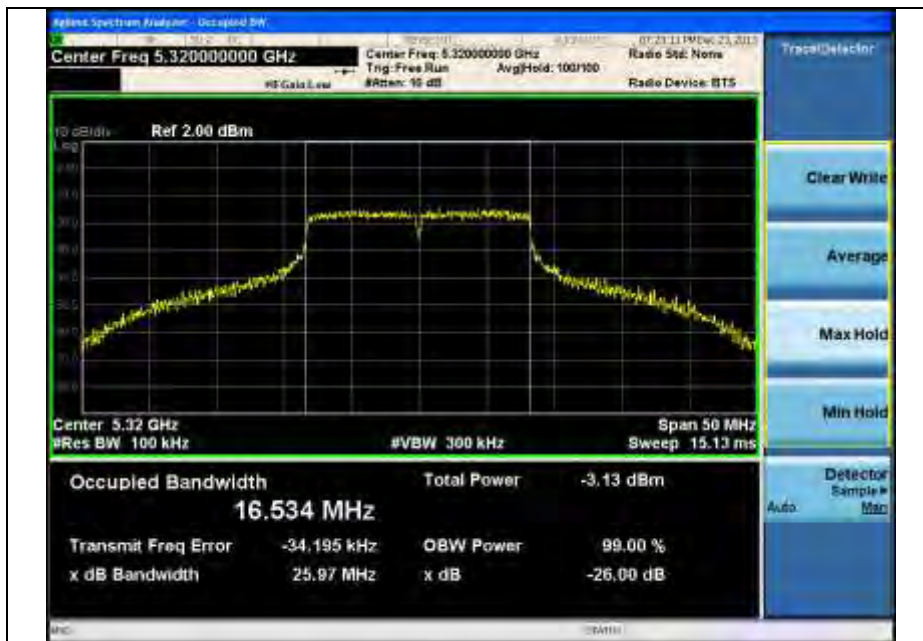

The results shown in this test report refer only to the sample(s) tested unless otherwise stated. This test report cannot be reproduced, except in full, without prior written permission of the Company.

802.11a (DFS)

Low Channel (5 500 MHz)

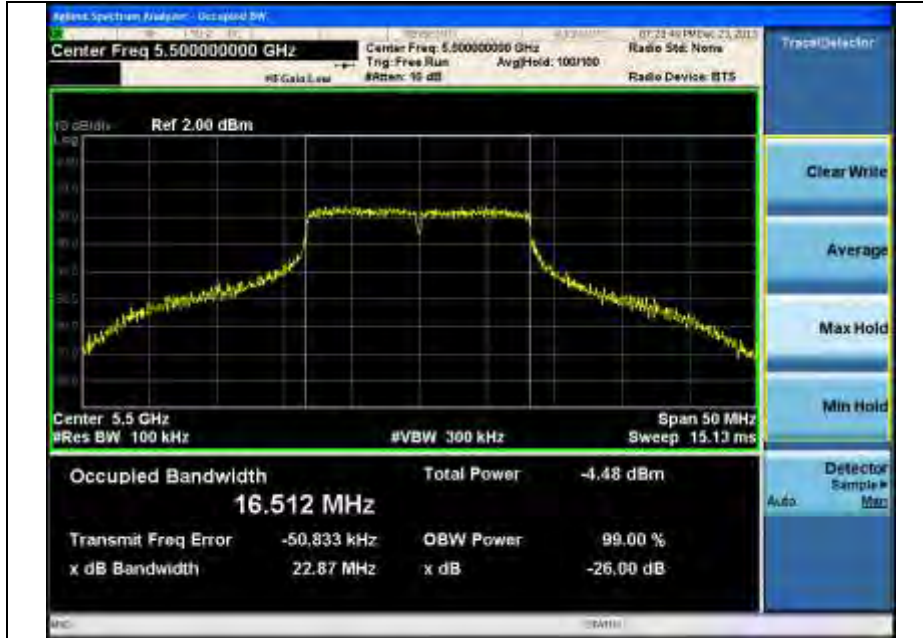

Middle Channel (5 580 MHz)

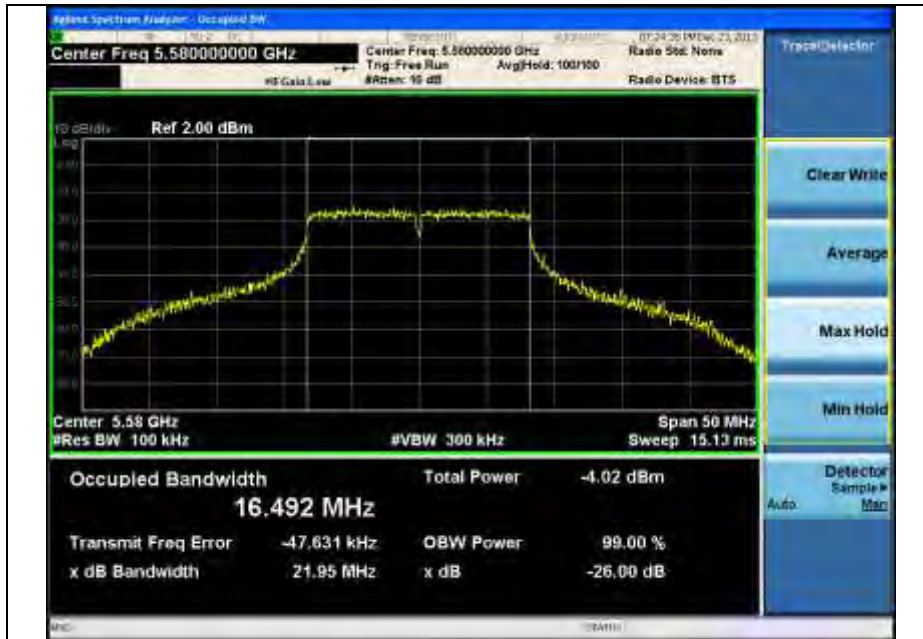

The results shown in this test report refer only to the sample(s) tested unless otherwise stated. This test report cannot be reproduced, except in full, without prior written permission of the Company.

High Channel (5 700 MHz)

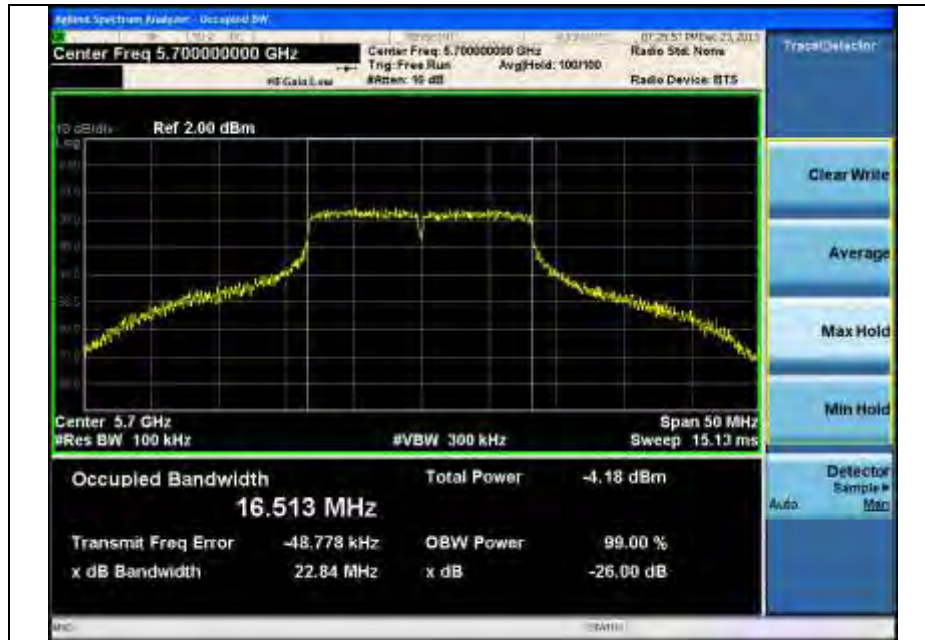

The results shown in this test report refer only to the sample(s) tested unless otherwise stated. This test report cannot be reproduced, except in full, without prior written permission of the Company.

802.11n_HT20 (Non-DFS)

Low Channel (5 180 MHz)



Middle Channel (5 220 MHz)



The results shown in this test report refer only to the sample(s) tested unless otherwise stated. This test report cannot be reproduced, except in full, without prior written permission of the Company.

High Channel (5 240 MHz)

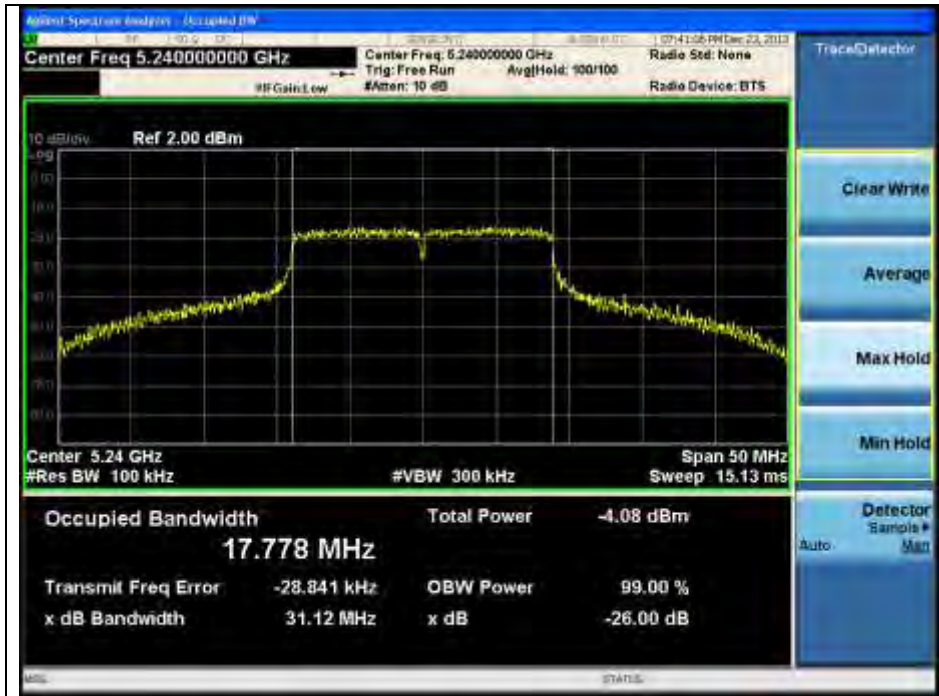

802.11n_HT20 (DFS)

Low Channel (5 260 MHz)



The results shown in this test report refer only to the sample(s) tested unless otherwise stated. This test report cannot be reproduced, except in full, without prior written permission of the Company.

Middle Channel (5 300 MHz)

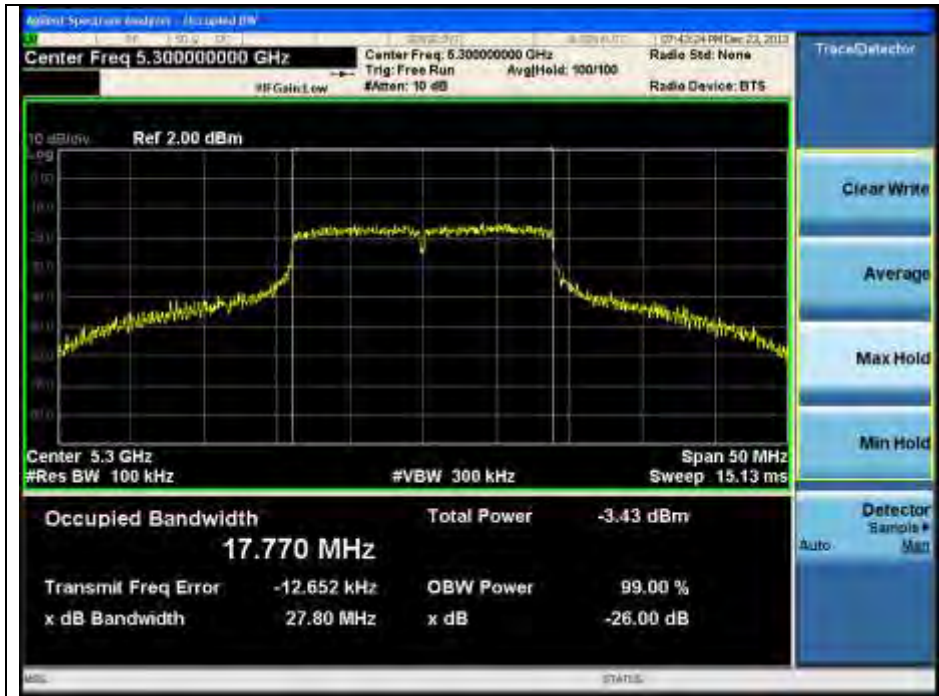

High Channel (5 320 MHz)



The results shown in this test report refer only to the sample(s) tested unless otherwise stated. This test report cannot be reproduced, except in full, without prior written permission of the Company.

802.11n_HT20 (DFS)

Low Channel (5 500 MHz)

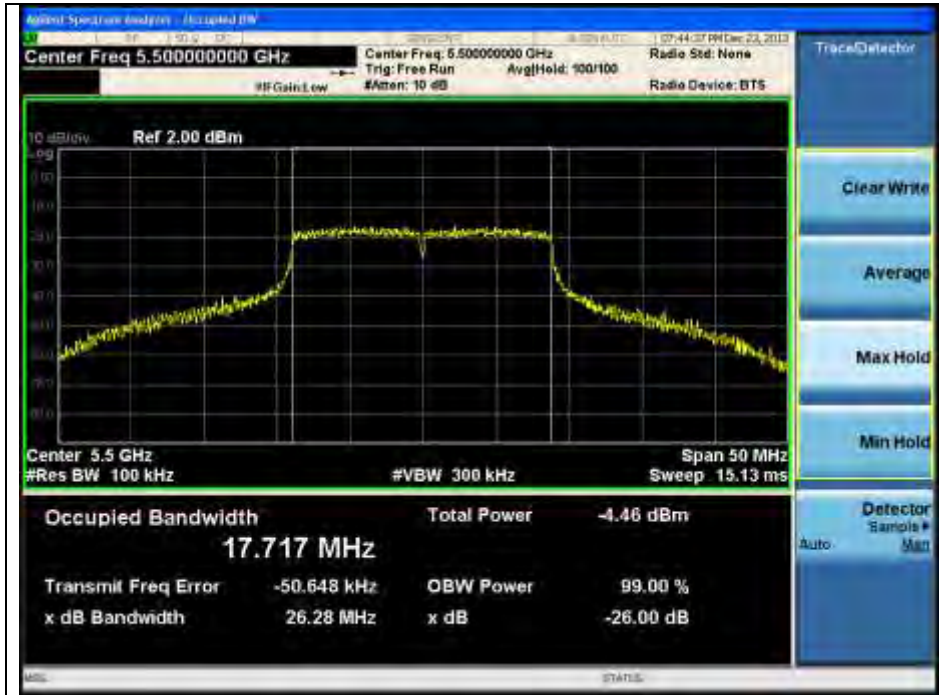

Middle Channel (5 580 MHz)



The results shown in this test report refer only to the sample(s) tested unless otherwise stated. This test report cannot be reproduced, except in full, without prior written permission of the Company.

High Channel (5 700 MHz)

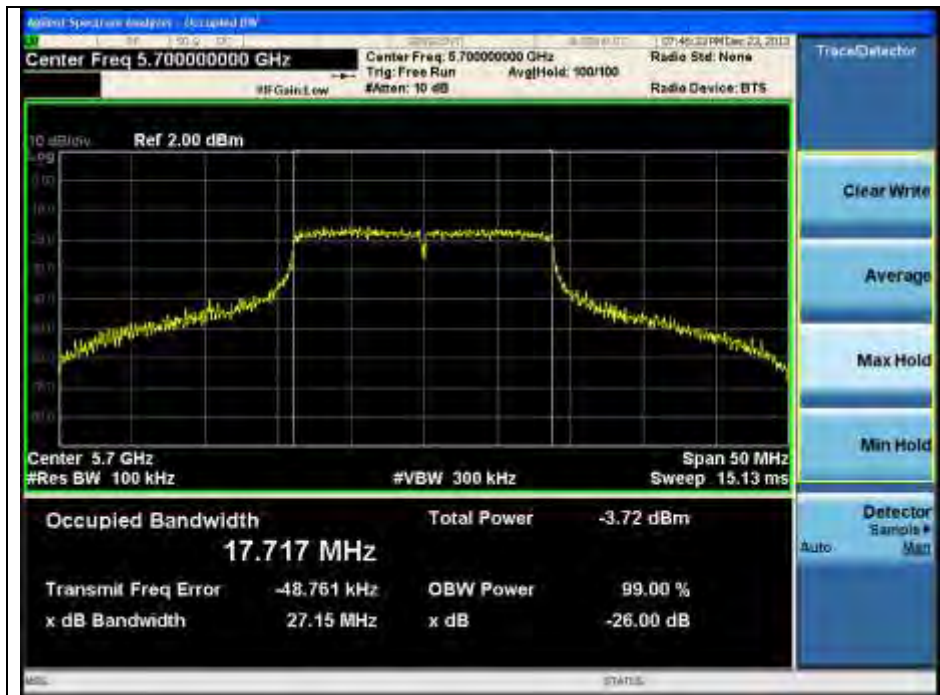

The results shown in this test report refer only to the sample(s) tested unless otherwise stated. This test report cannot be reproduced, except in full, without prior written permission of the Company.

802.11n_HT40 (Non-DFS)

Low Channel (5 190 MHz)



High Channel (5 230 MHz)



The results shown in this test report refer only to the sample(s) tested unless otherwise stated. This test report cannot be reproduced, except in full, without prior written permission of the Company.

802.11n_HT40 (DFS)

Low Channel (5 270 MHz)



High Channel (5 310 MHz)



The results shown in this test report refer only to the sample(s) tested unless otherwise stated. This test report cannot be reproduced, except in full, without prior written permission of the Company.

802.11n_HT40 (DFS)

Low Channel (5 510 MHz)



Low Channel (5 550 MHz)



The results shown in this test report refer only to the sample(s) tested unless otherwise stated. This test report cannot be reproduced, except in full, without prior written permission of the Company.

High Channel (5 670 MHz)



The results shown in this test report refer only to the sample(s) tested unless otherwise stated. This test report cannot be reproduced, except in full, without prior written permission of the Company.

4. Output power

4.1. Test setup

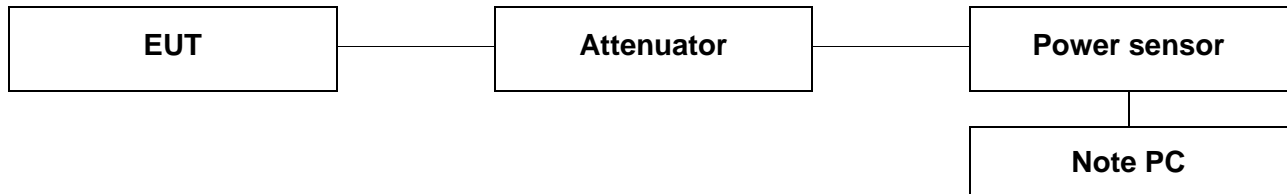

4.2. Limit

4.2.1. FCC 15.407

(a)(1)

For the 5.15-5.25 GHz band, the maximum conducted output power over the frequency band of operation shall not exceed the lesser of 50 mW or $4 \text{ dBm} + 10 \log B$, where B is the 26-dB emission bandwidth in MHz. If transmitting antennas of directional gain greater than 6 dBi are used, both the peak transmit power and the peak power spectral density shall be reduced by the amount in dB that the directional gain of the antenna exceeds 6 dBi.

(a)(2)

For the 5.25–5.35 GHz and 5.47–5.725 GHz bands, the maximum conducted output power over the frequency bands of operation shall not exceed the lesser of 250 mW or $11 \text{ dBm} + 10 \log B$, where B is the 26 dB emission bandwidth in megahertz. In addition, the peak power spectral density shall not exceed 11 dBm in any 1 megahertz band. If transmitting antennas of directional gain greater than 6 dBi are used, both the maximum conducted output power and the peak power spectral density shall be reduced by the amount in dB that the directional gain of the antenna exceeds 6 dBi.

4.2.2. IC RSS-210

A9.2(1) Band 5 150-5 250 MHz

The maximum e.i.r.p.. shall not exceed 200 mW or $10 + 10 \log_{10} B$, dBm, whichever power is less. B is the 99% emission bandwidth in MHz.

A9.2(2) Band 5 250-5 350 MHz

The maximum conducted output power shall not exceed 250 mW or $11 + 10 \log_{10} B$, dBm, whichever power is less. The maximum e.i.r.p.. shall not exceed 1.0 W or $17 + 10 \log_{10} B$, dBm, whichever power is less. B is the 99% emission bandwidth in MHz. Note that devices with a maximum e.i.r.p.. greater than 500 mW shall implement TPC in order to have the capability to operate at least 6 dB below the maximum permitted e.i.r.p. of 1 W.

A9.2(3) Band 5 600-5 650 MHz

The maximum conducted output power shall not exceed 250 mW or $11 + 10 \log_{10} B$, dBm, whichever power is less. The maximum e.i.r.p.. shall not exceed 1.0 W or $17 + 10 \log_{10} B$, dBm, whichever power is less. B is the 99% emission bandwidth in MHz. Note that devices with a maximum e.i.r.p.. greater than 500 mW shall implement TPC in order to have the capability to operate at least 6 dB below the maximum permitted e.i.r.p. of 1 W.

The results shown in this test report refer only to the sample(s) tested unless otherwise stated. This test report cannot be reproduced, except in full, without prior written permission of the Company.

4.3. Test procedure

1. This measurement settings are specified in clause 3) of section E of KDB 789033_v01r03.
2. Measurements may be performed using a wideband RF power meter with a thermocouple detector or equivalent if all of the conditions listed below are satisfied.
 - The EUT is configured to transmit continuously or to transmit with a consistent duty cycle.
 - At all times when the EUT is transmitting, it must be transmitting at its maximum power control level.
 - The integration period of the power meter exceeds the repetition period of the transmitted signal by at least a factor of five.
3. If the transmitter does not transmit continuously, measure the duty cycle, x , of the transmitter output signal as described in section B).
4. Measure the average power of the transmitter. This measurement is an average over both the on and off periods of the transmitter.
5. Adjust the measurement in dB m by adding $10 \log (1/x)$ where x is the duty cycle (e.g., $10 \log(1/0.25)$ if the duty cycle is 25 percent).

The results shown in this test report refer only to the sample(s) tested unless otherwise stated. This test report cannot be reproduced, except in full, without prior written permission of the Company.

4.4. Test result

Ambient temperature : (24 ± 2) °C
 Relative humidity : 49 % R.H.

4.4.1. FCC Limit

ANT0

-11a

Mode	Frequency (MHz)	Data Rate (Mbps)	Fixed Limit (dB m)	26 dB BW (MHz)	4+10LogB (dB m)	Antenna gain (dB i)	Limit (dB m)
11a	5 180	6	17	27.76	18.43	2.69	17
	5 220	6	17	28.45	18.54	2.69	17
	5 240	6	17	27.83	18.45	2.69	17
Mode	Frequency (MHz)	Data Rate (Mbps)	Fixed Limit (dB m)	26 dB BW (MHz)	11+10LogB (dB m)	Antenna gain (dB i)	Limit (dB m)
11a	5 260	6	24	29.69	25.73	2.69	24
	5 300	6	24	26.23	25.19	2.69	24
	5 320	6	24	26.63	25.25	2.69	24
	5 500	6	24	24.59	24.91	-0.26	24
	5 580	6	24	21.95	24.41	-0.26	24
	5 700	6	24	22.64	24.55	-0.26	24

-11n_HT20

Mode	Frequency (MHz)	Data Rate (Mbps)	Fixed Limit (dB m)	26 dB BW (MHz)	4+10LogB (dB m)	Antenna gain (dB i)	Limit (dB m)
11n_HT20	5 180	MCS8	17	29.71	18.73	2.69	17
	5 220	MCS8	17	29.64	18.72	2.69	17
	5 240	MCS8	17	29.35	18.68	2.69	17
Mode	Frequency (MHz)	Data Rate (Mbps)	Fixed Limit (dB m)	26 dB BW (MHz)	11+10LogB (dB m)	Antenna gain (dB i)	Limit (dB m)
11n_HT20	5 260	MCS8	24	29.36	25.68	2.69	24
	5 300	MCS8	24	29.25	25.66	2.69	24
	5 320	MCS8	24	29.13	25.64	2.69	24
	5 500	MCS8	24	25.51	25.07	-0.26	24
	5 580	MCS8	24	22.94	24.61	-0.26	24
	5 700	MCS8	24	26.58	25.25	-0.26	24

The results shown in this test report refer only to the sample(s) tested unless otherwise stated. This test report cannot be reproduced, except in full, without prior written permission of the Company.

-11n_HT40

Mode	Frequency (MHz)	Data Rate (Mbps)	Fixed Limit (dB m)	26 dB BW (MHz)	4+10LogB (dB m)	Antenna gain (dB i)	Limit (dB m)
11n_HT40	5 190	MCS8	17	49.86	20.98	2.69	17
	5 230	MCS8	17	50.00	20.99	2.69	17
Mode	Frequency (MHz)	Data Rate (Mbps)	Fixed Limit (dB m)	26 dB BW (MHz)	11+10LogB (dB m)	Antenna gain (dB i)	Limit (dB m)
11n_HT40	5 270	MCS8	24	48.08	27.82	2.69	24
	5 310	MCS8	24	45.3	27.56	2.69	24
	5 510	MCS8	24	44.74	27.51	-0.26	24
	5 550	MCS8	24	43.78	27.41	-0.26	24
	5 670	MCS8	24	45.17	27.55	-0.26	24

The results shown in this test report refer only to the sample(s) tested unless otherwise stated. This test report cannot be reproduced, except in full, without prior written permission of the Company.

ANT1
-11a

Mode	Frequency (MHz)	Data Rate (Mbps)	Fixed Limit (dB m)	26 dB BW (MHz)	4+10LogB (dB m)	Antenna gain (dB i)	Limit (dB m)
11a	5 180	6	17	29.13	18.64	2.50	17
	5 220	6	17	27.78	18.44	2.50	17
	5 240	6	17	27.98	18.47	2.50	17
Mode	Frequency (MHz)	Data Rate (Mbps)	Fixed Limit (dB m)	26 dB BW (MHz)	11+10LogB (dB m)	Antenna gain (dB i)	Limit (dB m)
11a	5 260	6	24	29.08	25.64	2.50	24
	5 300	6	24	26.96	25.31	2.50	24
	5 320	6	24	29.98	25.77	2.50	24
	5 500	6	24	26.10	25.17	-1.66	24
	5 580	6	24	23.92	24.79	-1.66	24
	5 700	6	24	23.74	24.75	-1.66	24

-11n_HT20

Mode	Frequency (MHz)	Data Rate (Mbps)	Fixed Limit (dB m)	26 dB BW (MHz)	4+10LogB (dB m)	Antenna gain (dB i)	Limit (dB m)
11n_HT20	5 180	MCS8	17	29.96	18.77	2.50	17
	5 220	MCS8	17	29.85	18.75	2.50	17
	5 240	MCS8	17	29.99	18.77	2.50	17
Mode	Frequency (MHz)	Data Rate (Mbps)	Fixed Limit (dB m)	26 dB BW (MHz)	11+10LogB (dB m)	Antenna gain (dB i)	Limit (dB m)
11n_HT20	5 260	MCS8	24	29.70	25.73	2.50	24
	5 300	MCS8	24	29.24	25.66	2.50	24
	5 320	MCS8	24	29.87	25.75	2.50	24
	5 500	MCS8	24	27.47	25.39	-1.66	24
	5 580	MCS8	24	25.67	25.09	-1.66	24
	5 700	MCS8	24	25.57	25.08	-1.66	24

The results shown in this test report refer only to the sample(s) tested unless otherwise stated. This test report cannot be reproduced, except in full, without prior written permission of the Company.

-11n_HT40

Mode	Frequency (MHz)	Data Rate (Mbps)	Fixed Limit (dB m)	26 dB BW (MHz)	4+10LogB (dB m)	Antenna gain (dB i)	Limit (dB m)
11n_HT40	5 190	MCS8	17	50.00	20.99	2.50	17
	5 230	MCS8	17	49.60	20.95	2.50	17
Mode	Frequency (MHz)	Data Rate (Mbps)	Fixed Limit (dB m)	26 dB BW (MHz)	11+10LogB (dB m)	Antenna gain (dB i)	Limit (dB m)
11n_HT40	5 270	MCS8	24	49.88	27.98	2.50	24
	5 310	MCS8	24	49.12	27.91	2.50	24
	5 510	MCS8	24	47.90	27.8	-1.66	24
	5 550	MCS8	24	47.58	27.77	-1.66	24
	5 670	MCS8	24	46.30	27.66	-1.66	24

The results shown in this test report refer only to the sample(s) tested unless otherwise stated. This test report cannot be reproduced, except in full, without prior written permission of the Company.

4.4.2. IC Limit

ANT0

-11a

Mode	Frequency (MHz)	Data Rate (Mbps)	Fixed Limit (dB m)	99% BW (MHz)	10+10LogB (dB m)	Antenna gain (dB i)	Limit (dB m)
11a	5 180	6	23	16.63	22.21	2.69	22.21
	5 220	6	23	16.57	22.19	2.69	22.19
	5 240	6	23	16.56	22.19	2.69	22.19
Mode	Frequency (MHz)	Data Rate (Mbps)	Fixed Limit (dB m)	99% BW (MHz)	11+10LogB (dB m)	Antenna gain (dB i)	Limit (dB m)
11a	5 260	6	24	16.58	23.20	2.69	23.20
	5 300	6	24	16.55	23.19	2.69	23.19
	5 320	6	24	16.55	23.19	2.69	23.19
	5 500	6	24	16.49	23.17	-0.26	23.17
	5 580	6	24	16.49	23.17	-0.26	23.17
	5 700	6	24	16.50	23.17	-0.26	23.17

-11n_HT20

Mode	Frequency (MHz)	Data Rate (Mbps)	Fixed Limit (dB m)	99% BW (MHz)	10+10LogB (dB m)	Antenna gain (dB i)	Limit (dB m)
11n_HT20	5 180	MCS8	23	17.80	22.50	2.69	22.50
	5 220	MCS8	23	17.78	22.50	2.69	22.50
	5 240	MCS8	23	17.82	22.51	2.69	22.51
Mode	Frequency (MHz)	Data Rate (Mbps)	Fixed Limit (dB m)	99% BW (MHz)	11+10LogB (dB m)	Antenna gain (dB i)	Limit (dB m)
11n_HT20	5 260	MCS8	24	17.79	23.50	2.69	23.50
	5 300	MCS8	24	17.73	23.49	2.69	23.49
	5 320	MCS8	24	17.77	23.50	2.69	23.50
	5 500	MCS8	24	17.71	23.48	-0.26	23.48
	5 580	MCS8	24	17.71	23.48	-0.26	23.48
	5 700	MCS8	24	17.72	23.48	-0.26	23.48

The results shown in this test report refer only to the sample(s) tested unless otherwise stated. This test report cannot be reproduced, except in full, without prior written permission of the Company.

-11n_HT40

Mode	Frequency (MHz)	Data Rate (Mbps)	Fixed Limit (dB m)	99% BW (MHz)	10+10LogB (dB m)	Antenna gain (dB i)	Limit (dB m)
11n_HT40	5 190	MCS8	23	36.16	25.58	2.69	23
	5 230	MCS8	23	36.17	25.58	2.69	23
Mode	Frequency (MHz)	Data Rate (Mbps)	Fixed Limit (dB m)	99% BW (MHz)	11+10LogB (dB m)	Antenna gain (dB i)	Limit (dB m)
11n_HT40	5 270	MCS8	24	36.13	26.58	2.69	24
	5 310	MCS8	24	36.13	26.58	2.69	24
	5 510	MCS8	24	36.16	26.58	-0.26	24
	5 550	MCS8	24	36.16	26.58	-0.26	24
	5 670	MCS8	24	36.14	26.58	-0.26	24

The results shown in this test report refer only to the sample(s) tested unless otherwise stated. This test report cannot be reproduced, except in full, without prior written permission of the Company.

ANT1
-11a

Mode	Frequency (MHz)	Data Rate (Mbps)	Fixed Limit (dB m)	99% BW (MHz)	10+10LogB (dB m)	Antenna gain (dB i)	Limit (dB m)
11a	5 180	6	23	16.59	22.20	2.50	22.20
	5 220	6	23	16.57	22.19	2.50	22.19
	5 240	6	23	16.57	22.19	2.50	22.19
Mode	Frequency (MHz)	Data Rate (Mbps)	Fixed Limit (dB m)	99% BW (MHz)	11+10LogB (dB m)	Antenna gain (dB i)	Limit (dB m)
11a	5 260	6	24	16.58	23.20	2.50	23.20
	5 300	6	24	16.55	23.19	2.50	23.19
	5 320	6	24	16.53	23.18	2.50	23.18
	5 500	6	24	16.51	23.18	-1.66	23.18
	5 580	6	24	16.49	23.17	-1.66	23.17
	5 700	6	24	16.51	23.18	-1.66	23.18

-11n_HT20

Mode	Frequency (MHz)	Data Rate (Mbps)	Fixed Limit (dB m)	99% BW (MHz)	10+10LogB (dB m)	Antenna gain (dB i)	Limit (dB m)
11n_HT20	5 180	MCS0	23	17.81	22.51	2.50	22.51
	5 220	MCS0	23	17.82	22.51	2.50	22.51
	5 240	MCS0	23	17.78	22.50	2.50	22.50
Mode	Frequency (MHz)	Data Rate (Mbps)	Fixed Limit (dB m)	99% BW (MHz)	11+10LogB (dB m)	Antenna gain (dB i)	Limit (dB m)
11n_HT20	5 260	MCS0	24	17.79	23.50	2.50	23.50
	5 300	MCS0	24	17.77	23.50	2.50	23.50
	5 320	MCS0	24	17.77	23.50	2.50	23.50
	5 500	MCS0	24	17.72	23.48	-1.66	23.48
	5 580	MCS0	24	17.71	23.48	-1.66	23.48
	5 700	MCS0	24	17.72	23.48	-1.66	23.48

The results shown in this test report refer only to the sample(s) tested unless otherwise stated. This test report cannot be reproduced, except in full, without prior written permission of the Company.

-11n_HT40

Mode	Frequency (MHz)	Data Rate (Mbps)	Fixed Limit (dB m)	99% BW (MHz)	10+10LogB (dB m)	Antenna gain (dB i)	Limit (dB m)
11n_HT40	5 190	MCS0	23	36.16	25.58	2.50	23
	5 230	MCS0	23	36.20	25.59	2.50	23
Mode	Frequency (MHz)	Data Rate (Mbps)	Fixed Limit (dB m)	99% BW (MHz)	11+10LogB (dB m)	Antenna gain (dB i)	Limit (dB m)
11n_HT40	5 270	MCS0	24	36.19	26.59	2.50	24
	5 310	MCS0	24	36.16	26.58	2.50	24
	5 510	MCS0	24	36.15	26.58	-1.66	24
	5 550	MCS0	24	36.15	26.58	-1.66	24
	5 670	MCS0	24	36.12	26.58	-1.66	24

The results shown in this test report refer only to the sample(s) tested unless otherwise stated. This test report cannot be reproduced, except in full, without prior written permission of the Company.

4.4.3. Result

-11a

Frequency [MHz]	Rated [Mbps]	Measured Power (Ant 0) [dBm]	Measured Power (Ant 1) [dBm]	Combined power (Ant 0 + Ant 1) [dBm]	Limit[dBm]	
					FCC	IC
5180	6	11.36	12.72	-	17	22.20
	9	11.32	12.67	-		
	12	11.31	12.62	-		
	18	11.25	12.60	-		
	24	11.22	12.59	-		
	36	11.19	12.54	-		
	48	11.16	12.48	-		
	54	11.15	12.44	-		
5220	6	11.75	12.30	-	17	22.19
	9	11.69	12.26	-		
	12	11.63	12.25	-		
	18	11.60	12.22	-		
	24	11.56	12.16	-		
	36	11.51	12.15	-		
	48	11.48	12.10	-		
	54	11.46	12.07	-		
5240	6	11.69	12.38	-	17	22.19
	9	11.65	12.36	-		
	12	11.61	12.35	-		
	18	11.57	12.32	-		
	24	11.52	12.31	-		
	36	11.49	12.28	-		
	48	11.46	12.26	-		
	54	11.45	12.23	-		

The results shown in this test report refer only to the sample(s) tested unless otherwise stated. This test report cannot be reproduced, except in full, without prior written permission of the Company.

Frequency [MHz]	Rated [Mbps]	Measured Power (Ant 0) [dBm]	Measured Power (Ant 1) [dBm]	Combined power (Ant 0 + Ant 1) [dBm]	Limit[dBm]	
					FCC	IC
5 260	6	14.39	15.03	-	24	23.20
	9	14.34	15.02	-		
	12	14.33	14.98	-		
	18	14.27	14.93	-		
	24	14.22	14.92	-		
	36	14.21	14.86	-		
	48	14.15	14.83	-		
	54	14.09	14.78	-		
5 300	6	13.69	14.46	-	24	23.19
	9	13.64	14.42	-		
	12	13.58	14.36	-		
	18	13.54	14.35	-		
	24	13.49	14.33	-		
	36	13.47	14.27	-		
	48	13.46	14.21	-		
	54	13.42	14.17	-		
5320	6	13.84	13.90	-	24	23.18
	9	13.78	13.87	-		
	12	13.74	13.85	-		
	18	13.72	13.83	-		
	24	13.68	13.77	-		
	36	13.66	13.75	-		
	48	13.61	13.72	-		
	54	13.60	13.69	-		

The results shown in this test report refer only to the sample(s) tested unless otherwise stated. This test report cannot be reproduced, except in full, without prior written permission of the Company.

Frequency [MHz]	Rated [Mbps]	Measured Power (Ant 0) [dBm]	Measured Power (Ant 1) [dBm]	Combined power (Ant 0 + Ant 1) [dBm]	Limit[dBm]	
					FCC	IC
5500	6	13.62	14.21	-	24	23.17
	9	13.61	14.19	-		
	12	13.60	14.18	-		
	18	13.55	14.16	-		
	24	13.54	14.14	-		
	36	13.48	14.13	-		
	48	13.42	14.10	-		
	54	13.38	14.08	-		
5580	6	15.03	<u>15.21</u>	-	24	23.17
	9	14.98	15.20	-		
	12	14.96	15.19	-		
	18	14.91	15.16	-		
	24	14.86	15.15	-		
	36	14.84	15.09	-		
	48	14.78	15.06	-		
	54	14.75	15.00	-		
5700	6	15.24	15.03	-	24	23.17
	9	15.23	14.98	-		
	12	15.18	14.96	-		
	18	15.15	14.93	-		
	24	15.10	14.92	-		
	36	15.07	14.91	-		
	48	15.01	14.90	-		
	54	15.00	14.87	-		

The results shown in this test report refer only to the sample(s) tested unless otherwise stated. This test report cannot be reproduced, except in full, without prior written permission of the Company.

-11n_HT20(Calculated)

Frequency [MHz]	Rated [Mbps]	Measured Power (Ant 0) [dB m]	Measured Power (Ant 1) [dB m]	Combined power (Ant 0 + Ant 1) [dB m]	Limit [dB m]	
					FCC	IC
5 180	MCS8	9.95	10.48	<u>13.23</u>	17	22.50
	MCS9	9.92	10.47	13.21		
	MCS10	9.91	10.45	13.20		
	MCS11	9.88	10.41	13.16		
	MCS12	9.83	10.39	13.13		
	MCS13	9.82	10.36	13.11		
	MCS14	9.78	10.35	13.08		
	MCS15	9.76	10.29	13.04		
5 220	MCS8	10.16	9.78	12.98	17	22.50
	MCS9	10.14	9.72	12.95		
	MCS10	10.11	9.69	12.92		
	MCS11	10.08	9.66	12.89		
	MCS12	10.02	9.64	12.84		
	MCS13	9.98	9.60	12.80		
	MCS14	9.94	9.58	12.77		
	MCS15	9.91	9.52	12.73		
5 240	MCS8	10.18	9.86	13.03	17	22.50
	MCS9	10.12	9.83	12.99		
	MCS10	10.10	9.81	12.97		
	MCS11	10.07	9.76	12.93		
	MCS12	10.05	9.72	12.90		
	MCS13	9.99	9.67	12.84		
	MCS14	9.94	9.65	12.81		
	MCS15	9.93	9.59	12.77		

The results shown in this test report refer only to the sample(s) tested unless otherwise stated. This test report cannot be reproduced, except in full, without prior written permission of the Company.

Frequency [MHz]	Rated [Mbps]	Measured Power (Ant 0) [dB m]	Measured Power (Ant 1) [dB m]	Combined power (Ant 0 + Ant 1) [dB m]	Limit [dB m]	
					FCC	IC
5 260	MCS8	11.94	12.19	<u>15.08</u>	24	23.50
	MCS9	11.93	12.17	15.06		
	MCS10	11.88	12.16	15.03		
	MCS11	11.87	12.15	15.02		
	MCS12	11.86	12.12	15.00		
	MCS13	11.80	12.11	14.97		
	MCS14	11.77	12.05	14.92		
	MCS15	11.71	12.02	14.88		
5 300	MCS8	11.85	11.92	14.90	24	23.49
	MCS9	11.79	11.87	14.84		
	MCS10	11.74	11.85	14.81		
	MCS11	11.73	11.83	14.79		
	MCS12	11.68	11.82	14.76		
	MCS13	11.63	11.76	14.71		
	MCS14	11.58	11.70	14.65		
	MCS15	11.53	11.69	14.62		
5 320	MCS8	11.05	11.26	14.17	24	23.50
	MCS9	10.99	11.23	14.12		
	MCS10	10.96	11.20	14.09		
	MCS11	10.90	11.18	14.05		
	MCS12	10.85	11.15	14.01		
	MCS13	10.83	11.09	13.97		
	MCS14	10.79	11.05	13.93		
	MCS15	10.73	11.02	13.89		

The results shown in this test report refer only to the sample(s) tested unless otherwise stated. This test report cannot be reproduced, except in full, without prior written permission of the Company.

Frequency [MHz]	Rated [Mbps]	Measured Power (Ant 0) [dB m]	Measured Power (Ant 1) [dB m]	Combined power (Ant 0 + Ant 1) [dB m]	Limit [dB m]	
					FCC	IC
5 500	MCS8	12.16	12.31	15.25	24	23.48
	MCS9	12.12	12.27	15.21		
	MCS10	12.11	12.26	15.20		
	MCS11	12.10	12.23	15.18		
	MCS12	12.09	12.22	15.17		
	MCS13	12.05	12.18	15.13		
	MCS14	12.00	12.16	15.09		
	MCS15	11.95	12.10	15.04		
5 580	MCS8	13.51	12.58	16.08	24	23.48
	MCS9	13.46	12.52	16.03		
	MCS10	13.41	12.48	15.98		
	MCS11	13.36	12.43	15.93		
	MCS12	13.33	12.37	15.89		
	MCS13	13.29	12.33	15.85		
	MCS14	13.24	12.27	15.79		
	MCS15	13.22	12.24	15.77		
5 700	MCS8	13.62	12.31	16.02	24	23.48
	MCS9	13.58	12.26	15.98		
	MCS10	13.54	12.22	15.94		
	MCS11	13.51	12.19	15.91		
	MCS12	13.49	12.17	15.89		
	MCS13	13.46	12.13	15.86		
	MCS14	13.44	12.09	15.83		
	MCS15	13.39	12.06	15.79		

The results shown in this test report refer only to the sample(s) tested unless otherwise stated. This test report cannot be reproduced, except in full, without prior written permission of the Company.

-11n_HT40

Frequency [MHz]	Rated [Mbps]	Measured Power (Ant 0) [dB m]	Measured Power (Ant 1) [dB m]	Combined power (Ant 0 + Ant1) [dB m]	Limit [dB m]	
					FCC	IC
5 190	MCS8	9.95	10.24	13.11	17	23
	MCS9	9.93	10.19	13.07		
	MCS10	9.87	10.16	13.03		
	MCS11	9.82	10.15	13.00		
	MCS12	9.79	10.14	12.98		
	MCS13	9.77	10.09	12.94		
	MCS14	9.71	10.06	12.90		
5 230	MCS8	9.84	10.29	13.08	17	23
	MCS9	9.82	10.24	13.05		
	MCS10	9.76	10.18	12.99		
	MCS11	9.74	10.15	12.96		
	MCS12	9.73	10.09	12.92		
	MCS13	9.69	10.07	12.89		
	MCS14	9.64	10.06	12.87		
5 270	MCS8	11.30	11.29	14.31	24	24
	MCS9	11.28	11.27	14.29		
	MCS10	11.25	11.21	14.24		
	MCS11	11.19	11.16	14.19		
	MCS12	11.15	11.10	14.14		
	MCS13	11.13	11.07	14.11		
	MCS14	11.07	11.03	14.06		
5 310	MCS8	10.49	10.68	13.60	24	24
	MCS9	10.47	10.67	13.58		
	MCS10	10.46	10.61	13.55		
	MCS11	10.43	10.59	13.52		
	MCS12	10.42	10.58	13.51		
	MCS13	10.39	10.53	13.47		
	MCS14	10.34	10.49	13.43		
MCS15	10.28	10.47	13.39			

The results shown in this test report refer only to the sample(s) tested unless otherwise stated. This test report cannot be reproduced, except in full, without prior written permission of the Company.

Frequency [MHz]	Rated [Mbps]	Measured Power (Ant 0) [dB m]	Measured Power (Ant 1) [dB m]	Combined power (Ant 0 + Ant1) [dB m]	Limit [dB m]	
					FCC	IC
5 510	MCS8	8.64	8.19	11.43	24	24
	MCS9	8.60	8.14	11.39		
	MCS10	8.57	8.12	11.36		
	MCS11	8.56	8.11	11.35		
	MCS12	8.54	8.06	11.32		
	MCS13	8.53	8.03	11.30		
	MCS14	8.50	8.01	11.27		
	MCS15	8.46	8.00	11.25		
5 550	MCS8	9.64	9.17	12.42	24	24
	MCS9	9.62	9.13	12.39		
	MCS10	9.57	9.10	12.35		
	MCS11	9.54	9.09	12.33		
	MCS12	9.51	9.05	12.30		
	MCS13	9.48	9.00	12.26		
	MCS14	9.42	8.94	12.20		
	MCS15	9.40	8.93	12.18		
5 670	MCS8	9.79	8.94	12.40	24	24
	MCS9	9.73	8.91	12.35		
	MCS10	9.69	8.87	12.31		
	MCS11	9.63	8.83	12.26		
	MCS12	9.58	8.82	12.23		
	MCS13	9.54	8.81	12.20		
	MCS14	9.50	8.75	12.15		
	MCS15	9.48	8.70	12.12		

Remark

According to KDB662911, average power of each port (ANT0 and ANT1) was combined by using below calculation.

Ant 0+Ant 1 (Calculated)

Combined power : $10\log\{10^{(\text{Ant 0_Measured Power}/10)}+10^{(\text{Ant 1_Measured Power}/10)}\}$

The results shown in this test report refer only to the sample(s) tested unless otherwise stated. This test report cannot be reproduced, except in full, without prior written permission of the Company.

5. Peak power spectral density

5.1. Test setup



5.2. Limit

5.2.1. FCC 15.407

(a)(1)

For the band 5.15–5.25 GHz band, the peak power spectral density shall not exceed 4 dBm in any 1 MHz band. If transmitting antennas of directional gain greater than 6 dBi are used, both the peak transmit power and the peak power spectral density shall be reduced by the amount in dB that the directional gain of the antenna exceeds 6 dBi.

(a)(2)

For the band 5.25–5.35 GHz and 5.47–5.725 GHz bands, the peak power spectral density shall not exceed 11 dBm in any 1 megahertz band. If transmitting antennas of directional gain greater than 6 dBi are used, both the maximum conducted output power and the peak power spectral density shall be reduced by the amount in dB that the directional gain of the antenna exceeds 6 dBi.

5.2.2. IC RSS-210

A9.2(1) Band 5 150-5 250 MHz

The e.i.r.p.. spectral density shall not exceed 10 dBm in any 1.0 MHz band.

A9.2(2) Band 5 250-5 350 MHz

The power spectral density shall not exceed 11 dBm in any 1.0 MHz band.

A9.2(3) Band 5 600-5 650 MHz

The power spectral density shall not exceed 11 dBm in any 1.0 MHz band.

The results shown in this test report refer only to the sample(s) tested unless otherwise stated. This test report cannot be reproduced, except in full, without prior written permission of the Company.

5.3. Test procedure

All data rates and modes were investigated for this test. The full data for the worst case data rate are reported in this section.

1. This measurement settings are specified in clause b) Method SA-1 of section E of KDB 789033_v01r03.
2. Set span to encompass the 26 dB EBW (or, alternatively, the entire 99% occupied bandwidth) of the signal.
3. Set RBW = 1 MHz
4. Set VBW \geq 3 MHz
5. Number of points in sweep \geq 2 Span / RBW. (This ensures that bin-to-bin spacing is \leq RBW/2, so that narrowband signals are not lost between frequency bins.)
6. Sweep time = auto.
7. Detector = RMS (i.e., power averaging), if available. Otherwise, use sample detector mode.
8. Do not use sweep triggering. Allow the sweep to "free run".
9. Trace average at least 100 traces in power averaging (i.e., RMS) mode.
10. Use the peak search function on the spectrum analyzer to find the peak of the spectrum.
11. The result is the PPSD.

The results shown in this test report refer only to the sample(s) tested unless otherwise stated. This test report cannot be reproduced, except in full, without prior written permission of the Company.

5.4. Test result

Ambient temperature : (24 ± 2) °C
 Relative humidity : 49 % R.H.

- 802.11a

Frequency (MHz)	Data Rate (Mbps)	Ant 0_Measured PSD (dB m)	Ant 1_Measured PSD (dB m)	Limit (dB m)
5 180	6	1.567	1.848	4
5 220	6	1.833	1.826	4
5 240	6	1.696	0.915	4
5 260	6	2.228	0.917	11
5 300	6	2.740	0.902	11
5 320	6	2.668	1.766	11
5 500	6	0.262	-0.489	11
5 580	6	1.030	0.267	11
5 700	6	0.694	1.339	11

- 802.11n_HT20(Calculated)

Frequency (MHz)	Data Rate (Mbps)	Ant 0_Measured PSD (dB m)	Ant 1_Measured PSD (dB m)	Ant 0 + Ant 1 Result (dB m)	Limit (dB m)
5 180	MCS8	-1.343	-1.606	1.538	4
5 220	MCS8	-2.451	-1.367	1.135	4
5 240	MCS8	-1.690	-1.323	1.508	4
5 260	MCS8	1.259	1.412	4.346	11
5 300	MCS8	0.867	1.265	4.081	11
5 320	MCS8	0.588	2.186	4.470	11
5 500	MCS8	-0.607	-0.853	2.282	11
5 580	MCS8	-0.594	0.098	2.776	11
5 700	MCS8	-0.688	1.610	3.622	11

The results shown in this test report refer only to the sample(s) tested unless otherwise stated. This test report cannot be reproduced, except in full, without prior written permission of the Company.

- 802.11n_HT40(Calculated)

Frequency (MHz)	Data Rate (Mbps)	Ant 0_Measured PSD (dB m)	Ant 1_Measured PSD (dB m)	Ant 0 + Ant 1 Result (dB m)	Limit (dB m)
5 190	MCS8	-2.886	-0.906	1.226	4
5 230	MCS8	-1.956	-2.138	0.964	4
5 270	MCS8	-2.316	-1.618	1.057	4
5 310	MCS8	-5.117	-3.262	-1.081	11
5 510	MCS8	-5.665	-6.731	-3.155	11
5 550	MCS8	-4.867	-5.313	-2.074	11
5 670	MCS8	-5.162	-3.041	-0.963	11

Note;

- Ant0+Ant1 (Calculated)
- Result : $10 \cdot \log\{10^{(\text{Ant0_Measured PSD}/10)} + 10^{(\text{Ant1_Measured PSD}/10)}\}$
- In case of the Data Rate, record the Data Rate of the worst case

The results shown in this test report refer only to the sample(s) tested unless otherwise stated. This test report cannot be reproduced, except in full, without prior written permission of the Company.

Ant 0

802.11a (6 Mbps)

Low Channel (5 180 MHz)



Middle Channel (5 220 MHz)



The results shown in this test report refer only to the sample(s) tested unless otherwise stated. This test report cannot be reproduced, except in full, without prior written permission of the Company.

High Channel (5 240 MHz)



Low Channel (5 260 MHz)



The results shown in this test report refer only to the sample(s) tested unless otherwise stated. This test report cannot be reproduced, except in full, without prior written permission of the Company.

Middle Channel (5 300 MHz)



High Channel (5 320 MHz)



The results shown in this test report refer only to the sample(s) tested unless otherwise stated. This test report cannot be reproduced, except in full, without prior written permission of the Company.

Low Channel (5 500 MHz)



Middle Channel (5 580 MHz)



The results shown in this test report refer only to the sample(s) tested unless otherwise stated. This test report cannot be reproduced, except in full, without prior written permission of the Company.

High Channel (5 700 MHz)



The results shown in this test report refer only to the sample(s) tested unless otherwise stated. This test report cannot be reproduced, except in full, without prior written permission of the Company.

802.11n_HT20 (MCS8)

Low Channel (5 180 MHz)



Middle Channel (5 220 MHz)



The results shown in this test report refer only to the sample(s) tested unless otherwise stated. This test report cannot be reproduced, except in full, without prior written permission of the Company.

High Channel (5 240 MHz)



Low Channel (5 260 MHz)



The results shown in this test report refer only to the sample(s) tested unless otherwise stated. This test report cannot be reproduced, except in full, without prior written permission of the Company.

Middle Channel (5 300 MHz)



High Channel (5 320 MHz)



The results shown in this test report refer only to the sample(s) tested unless otherwise stated. This test report cannot be reproduced, except in full, without prior written permission of the Company.

Low Channel (5 500 MHz)



Middle Channel (5 580 MHz)



The results shown in this test report refer only to the sample(s) tested unless otherwise stated. This test report cannot be reproduced, except in full, without prior written permission of the Company.

High Channel (5 700 MHz)



The results shown in this test report refer only to the sample(s) tested unless otherwise stated. This test report cannot be reproduced, except in full, without prior written permission of the Company.

802.11n_HT40 (MCS8)

Low Channel (5 190 MHz)



High Channel (5 230 MHz)



The results shown in this test report refer only to the sample(s) tested unless otherwise stated. This test report cannot be reproduced, except in full, without prior written permission of the Company.

Low Channel (5 270 MHz)



High Channel (5 310 MHz)



The results shown in this test report refer only to the sample(s) tested unless otherwise stated. This test report cannot be reproduced, except in full, without prior written permission of the Company.

Low Channel (5 510 MHz)



Middle Channel (5 550 MHz)



The results shown in this test report refer only to the sample(s) tested unless otherwise stated. This test report cannot be reproduced, except in full, without prior written permission of the Company.

High Channel (5 670 MHz)



The results shown in this test report refer only to the sample(s) tested unless otherwise stated. This test report cannot be reproduced, except in full, without prior written permission of the Company.

Ant 1

802.11a (6 Mbps)

Low Channel (5 180 MHz)



Middle Channel (5 220 MHz)



The results shown in this test report refer only to the sample(s) tested unless otherwise stated. This test report cannot be reproduced, except in full, without prior written permission of the Company.

High Channel (5 240 MHz)



Low Channel (5 260 MHz)



The results shown in this test report refer only to the sample(s) tested unless otherwise stated. This test report cannot be reproduced, except in full, without prior written permission of the Company.

Middle Channel (5 300 MHz)



High Channel (5 320 MHz)



The results shown in this test report refer only to the sample(s) tested unless otherwise stated. This test report cannot be reproduced, except in full, without prior written permission of the Company.

Low Channel (5 500 MHz)



Middle Channel (5 580 MHz)



The results shown in this test report refer only to the sample(s) tested unless otherwise stated. This test report cannot be reproduced, except in full, without prior written permission of the Company.

High Channel (5 700 MHz)



The results shown in this test report refer only to the sample(s) tested unless otherwise stated. This test report cannot be reproduced, except in full, without prior written permission of the Company.

802.11n_HT20 (MCS8)

Low Channel (5 180 MHz)



Middle Channel (5 220 MHz)



The results shown in this test report refer only to the sample(s) tested unless otherwise stated. This test report cannot be reproduced, except in full, without prior written permission of the Company.

High Channel (5 240 MHz)



Low Channel (5 260 MHz)



The results shown in this test report refer only to the sample(s) tested unless otherwise stated. This test report cannot be reproduced, except in full, without prior written permission of the Company.

Middle Channel (5 300 MHz)



High Channel (5 320 MHz)



The results shown in this test report refer only to the sample(s) tested unless otherwise stated. This test report cannot be reproduced, except in full, without prior written permission of the Company.

Low Channel (5 500 MHz)



Middle Channel (5 580 MHz)



The results shown in this test report refer only to the sample(s) tested unless otherwise stated. This test report cannot be reproduced, except in full, without prior written permission of the Company.

High Channel (5 700 MHz)



The results shown in this test report refer only to the sample(s) tested unless otherwise stated. This test report cannot be reproduced, except in full, without prior written permission of the Company.

802.11n_HT40 (MCS8)

Low Channel (5 190 MHz)



High Channel (5 230 MHz)



The results shown in this test report refer only to the sample(s) tested unless otherwise stated. This test report cannot be reproduced, except in full, without prior written permission of the Company.

Low Channel (5 270 MHz)



High Channel (5 310 MHz)



The results shown in this test report refer only to the sample(s) tested unless otherwise stated. This test report cannot be reproduced, except in full, without prior written permission of the Company.

Low Channel (5 510 MHz)



Middle Channel (5 550 MHz)



The results shown in this test report refer only to the sample(s) tested unless otherwise stated. This test report cannot be reproduced, except in full, without prior written permission of the Company.

High Channel (5 670 MHz)



The results shown in this test report refer only to the sample(s) tested unless otherwise stated. This test report cannot be reproduced, except in full, without prior written permission of the Company.

6. Peak excursion

6.1. Test setup

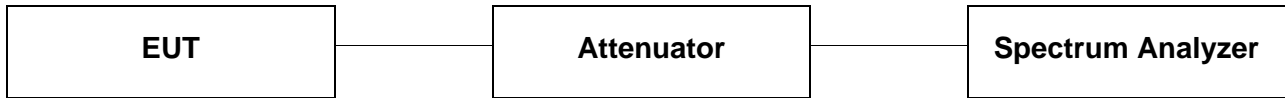

6.2. Limit

The ratio of the peak excursion of the modulation envelope (measured using a peak hold function) to the peak transmit power (measured as specified above) shall not exceed 13 dB across any 1 MHz bandwidth or the emission bandwidth whichever is less.

6.3. Test procedure

All data rates and modes were investigated for this test. The full data for the worst case data rate are reported in this section.

1. This measurement settings are specified in section G of KDB 789033_v01r03.
2. Set the spectrum analyzer or EMI receiver span to view the entire emission bandwidth.
3. Find the maximum of the peak-max-hold spectrum.
4. Set RBW = 1 MHz.
5. Set VBW \geq 3 MHz.
6. Detector = Peak.
7. Trace mode = max-hold.
8. Allow the sweeps to continue until the trace stabilizes.
9. Use the peak search function to find the peak of the spectrum.
10. Compute the ratio of the maximum of the peak-max-hold spectrum to the PPSD.
 - Testing each modulation mode on a single channel in a single operating band is sufficient to demonstrate compliance with the peak excursion requirement.
 - Tests performed all signal types, all modulation types, all bandwidth modes, all variations in signal parameters.

The results shown in this test report refer only to the sample(s) tested unless otherwise stated. This test report cannot be reproduced, except in full, without prior written permission of the Company.

6.4. Test result

Ambient temperature : (24 ± 2) °C
 Relative humidity : 49 % R.H.

- 11a

Channel No.	Frequency (MHz)	Data Rate (Mbps)	Peak excursion (dB)	Limit (dB)
36	5 180	6	8.063	13
		9	8.020	
		12	9.086	
		18	8.956	
		24	8.971	
		36	9.471	
		48	9.494	
		54	9.258	

- 11n_HT20

Channel No.	Frequency (MHz)	Data Rate (Mbps)	Peak excursion (dB)	Limit (dB)
36	5 180	MCS0	8.589	13
		MCS1	8.873	
		MCS2	9.076	
		MCS3	8.971	
		MCS4	8.684	
		MCS5	9.205	
		MCS6	8.919	
		MCS7	9.348	
		MCS8	8.515	
		MCS9	9.489	
		MCS10	9.391	
		MCS11	9.363	
		MCS12	9.463	
		MCS13	7.809	
		MCS14	7.728	
MCS15	7.658			

The results shown in this test report refer only to the sample(s) tested unless otherwise stated. This test report cannot be reproduced, except in full, without prior written permission of the Company.

- 11n_HT40

Channel No.	Frequency (MHz)	Data Rate (Mbps)	Peak excursion (dB)	Limit (dB)
38	5 190	MCS0	8.106	13
		MCS1	8.607	
		MCS2	9.539	
		MCS3	8.684	
		MCS4	8.474	
		MCS5	9.320	
		MCS6	8.909	
		MCS7	9.398	
		MCS8	8.297	
		MCS9	8.009	
		MCS10	9.151	
		MCS11	8.930	
		MCS12	9.185	
		MCS13	8.649	
		MCS14	9.949	
MCS15	8.934			

The results shown in this test report refer only to the sample(s) tested unless otherwise stated. This test report cannot be reproduced, except in full, without prior written permission of the Company.

- 11a

5 180 MHz(6 Mbps)



5 180 MHz(9 Mbps)



The results shown in this test report refer only to the sample(s) tested unless otherwise stated. This test report cannot be reproduced, except in full, without prior written permission of the Company.

5 180 MHz(12 Mbps)



5 180 MHz(18 Mbps)



The results shown in this test report refer only to the sample(s) tested unless otherwise stated. This test report cannot be reproduced, except in full, without prior written permission of the Company.

5 180 MHz(24 Mbps)



5 180 MHz(36 Mbps)



The results shown in this test report refer only to the sample(s) tested unless otherwise stated. This test report cannot be reproduced, except in full, without prior written permission of the Company.

5 180 MHz(48 Mbps)



5 180 MHz(54 Mbps)



The results shown in this test report refer only to the sample(s) tested unless otherwise stated. This test report cannot be reproduced, except in full, without prior written permission of the Company.

- 11n_HT20

5 180 MHz(MCS0)



5 180 MHz(MCS1)



The results shown in this test report refer only to the sample(s) tested unless otherwise stated. This test report cannot be reproduced, except in full, without prior written permission of the Company.

5 180 MHz(MCS2)



5 180 MHz(MCS3)



The results shown in this test report refer only to the sample(s) tested unless otherwise stated. This test report cannot be reproduced, except in full, without prior written permission of the Company.

5 180 MHz(MCS4)



5 180 MHz(MCS5)



The results shown in this test report refer only to the sample(s) tested unless otherwise stated. This test report cannot be reproduced, except in full, without prior written permission of the Company.

5 180 MHz(MCS6)



5 180 MHz(MCS7)

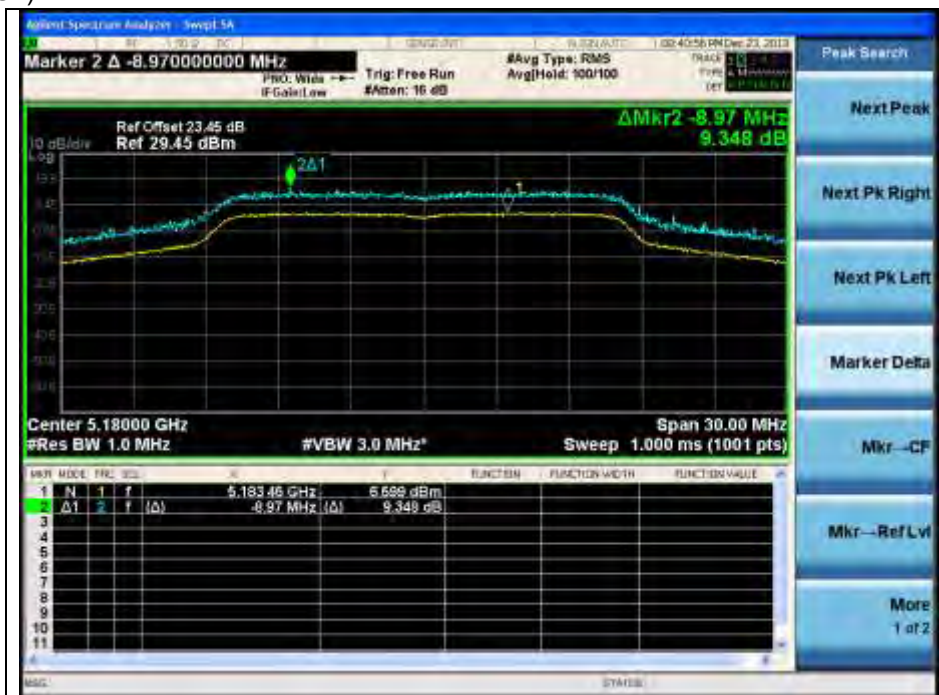

The results shown in this test report refer only to the sample(s) tested unless otherwise stated. This test report cannot be reproduced, except in full, without prior written permission of the Company.

5 180 MHz(MCS8)



5 180 MHz(MCS9)



The results shown in this test report refer only to the sample(s) tested unless otherwise stated. This test report cannot be reproduced, except in full, without prior written permission of the Company.

5 180 MHz(MCS10)



5 180 MHz(MCS11)



The results shown in this test report refer only to the sample(s) tested unless otherwise stated. This test report cannot be reproduced, except in full, without prior written permission of the Company.

5 180 MHz(MCS12)



5 180 MHz(MCS13)



The results shown in this test report refer only to the sample(s) tested unless otherwise stated. This test report cannot be reproduced, except in full, without prior written permission of the Company.

5 180 MHz(MCS14)



5 180 MHz(MCS15)



The results shown in this test report refer only to the sample(s) tested unless otherwise stated. This test report cannot be reproduced, except in full, without prior written permission of the Company.

- 11n_HT40

5 190 MHz(MCS0)



5 190 MHz(MCS1)



The results shown in this test report refer only to the sample(s) tested unless otherwise stated. This test report cannot be reproduced, except in full, without prior written permission of the Company.

5 190 MHz(MCS2)



5 190 MHz(MCS3)



The results shown in this test report refer only to the sample(s) tested unless otherwise stated. This test report cannot be reproduced, except in full, without prior written permission of the Company.

5 190 MHz(MCS4)



5 190 MHz(MCS5)



The results shown in this test report refer only to the sample(s) tested unless otherwise stated. This test report cannot be reproduced, except in full, without prior written permission of the Company.

5 190 MHz(MCS6)



5 190 MHz(MCS7)



The results shown in this test report refer only to the sample(s) tested unless otherwise stated. This test report cannot be reproduced, except in full, without prior written permission of the Company.

5 190 MHz(MCS8)



5 190 MHz(MCS9)



The results shown in this test report refer only to the sample(s) tested unless otherwise stated. This test report cannot be reproduced, except in full, without prior written permission of the Company.

5 190 MHz(MCS10)



5 190 MHz(MCS11)



The results shown in this test report refer only to the sample(s) tested unless otherwise stated. This test report cannot be reproduced, except in full, without prior written permission of the Company.

5 190 MHz(MCS12)



5 190 MHz(MCS13)



The results shown in this test report refer only to the sample(s) tested unless otherwise stated. This test report cannot be reproduced, except in full, without prior written permission of the Company.

5 190 MHz(MCS14)



5 190 MHz(MCS15)



The results shown in this test report refer only to the sample(s) tested unless otherwise stated. This test report cannot be reproduced, except in full, without prior written permission of the Company.

7. Transmitter AC Power Line Conducted Emission

7.1. Test Setup

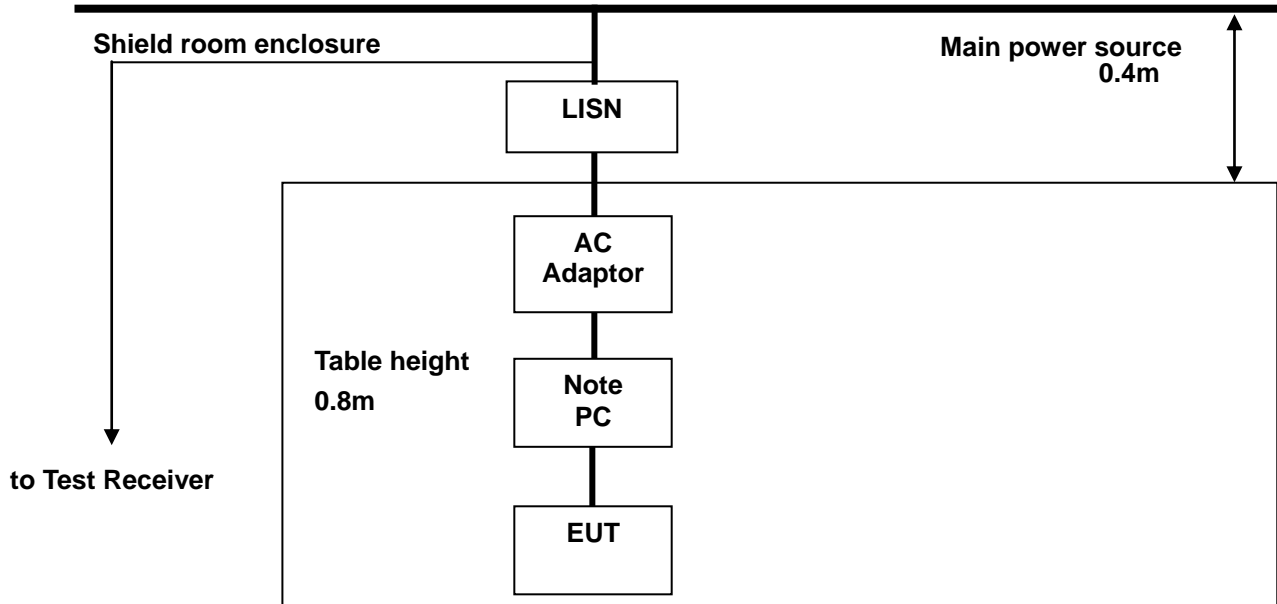

7.2. Limit

According to §15.207(a) for an intentional radiator that is designed to be connected to the public utility (AC) power line, the radio frequency voltage that is conducted back onto the AC power line on any frequency or frequencies, within the band 150 kHz to 30 MHz, shall not exceed the limits in the following table, as measured using a 50 uH/50 ohm line impedance stabilization network(LISN).

Compliance with the provision of this paragraph shall on the measurement of the radio frequency voltage between each power line and ground at the power terminal. The lower applies at the boundary between the frequency ranges.

Frequency of Emission (MHz)	Conducted limit (dB μ V)	
	Quasi-peak	Average
0.15 – 0.50	66 - 56*	56 - 46*
0.50 – 5.00	56	46
5.00 – 30.0	60	50

* Decreases with the logarithm of the frequency.

The results shown in this test report refer only to the sample(s) tested unless otherwise stated. This test report cannot be reproduced, except in full, without prior written permission of the Company.

7.3. Test Procedures

All data rates and modes were investigated for this test. The full data for the worst case data rate are reported in this section.

AC line conducted emissions from the EUT were measured according to the dictates of ANSI C63.4-2003

1. The test procedure is performed in a 6.5m × 3.6m × 3.6m (L × W × H) shielded room. The EUT along with its peripherals were placed on a 1.0 m(W) × 1.5 m(L) and 0.8 m in height wooden table and the EUT was adjusted to maintain a 0.4 meter space from a vertical reference plane.
2. The EUT was connected to power mains through a line impedance stabilization network (LISN) which provides 50 ohm coupling impedance for measuring instrument and the chassis ground was bounded to the horizontal ground plane of shielded room.
3. The excess power cable between the EUT and the LISN was bundled. All connecting cables of EUT were moved to find the maximum emission.

The results shown in this test report refer only to the sample(s) tested unless otherwise stated. This test report cannot be reproduced, except in full, without prior written permission of the Company.

7.4. Test Results (Worst case configuration_ 11a mode_6Mbps)

The following table shows the highest levels of conducted emissions on both phase of Hot and Neutral line.

Ambient temperature : (24 ± 2) °C
 Relative humidity : 47 % R.H.

Frequency range : 0.15 MHz – 30 MHz
 Measured Bandwidth : 9 kHz

FREQ. (MHz)	LEVEL(dB μ V)		LINE	LIMIT(dB μ V)		MARGIN(dB)	
	Q-Peak	Average		Q-Peak	Average	Q-Peak	Average
0.15	43.67	22.17	H	66.00	56.00	22.33	33.83
0.23	34.67	19.57	H	62.45	52.45	27.78	32.88
0.37	26.47	23.17	H	58.50	48.50	32.03	25.33
1.10	23.48	20.78	H	56.00	46.00	32.52	25.22
1.91	27.31	24.31	H	56.00	46.00	28.69	21.69
4.38	12.95	9.85	H	56.00	46.00	43.05	36.15
0.15	43.35	22.75	N	66.00	56.00	22.65	33.25
0.25	32.95	21.65	N	61.76	51.76	28.81	30.11
0.37	26.75	23.95	N	58.50	48.50	31.75	24.55
0.75	23.86	21.76	N	56.00	46.00	32.14	24.24
1.50	26.37	24.57	N	56.00	46.00	29.63	21.43
1.89	27.38	24.68	N	56.00	46.00	28.62	21.32

Note ;

1. Line (H): Hot, Line (N): Neutral
2. All modes of operation were investigated and the worst-case emissions are reported using 11a_6Mbps
3. The limit for Class B device(s) from 150 kHz to 30 MHz are specified in Section of the Title 47 CFR.
4. Traces shown in plot mad using a peak detector and average detector
5. Deviations to the Specifications: None.

The results shown in this test report refer only to the sample(s) tested unless otherwise stated. This test report cannot be reproduced, except in full, without prior written permission of the Company.

Plot of Conducted Power line

Test mode : (Hot)

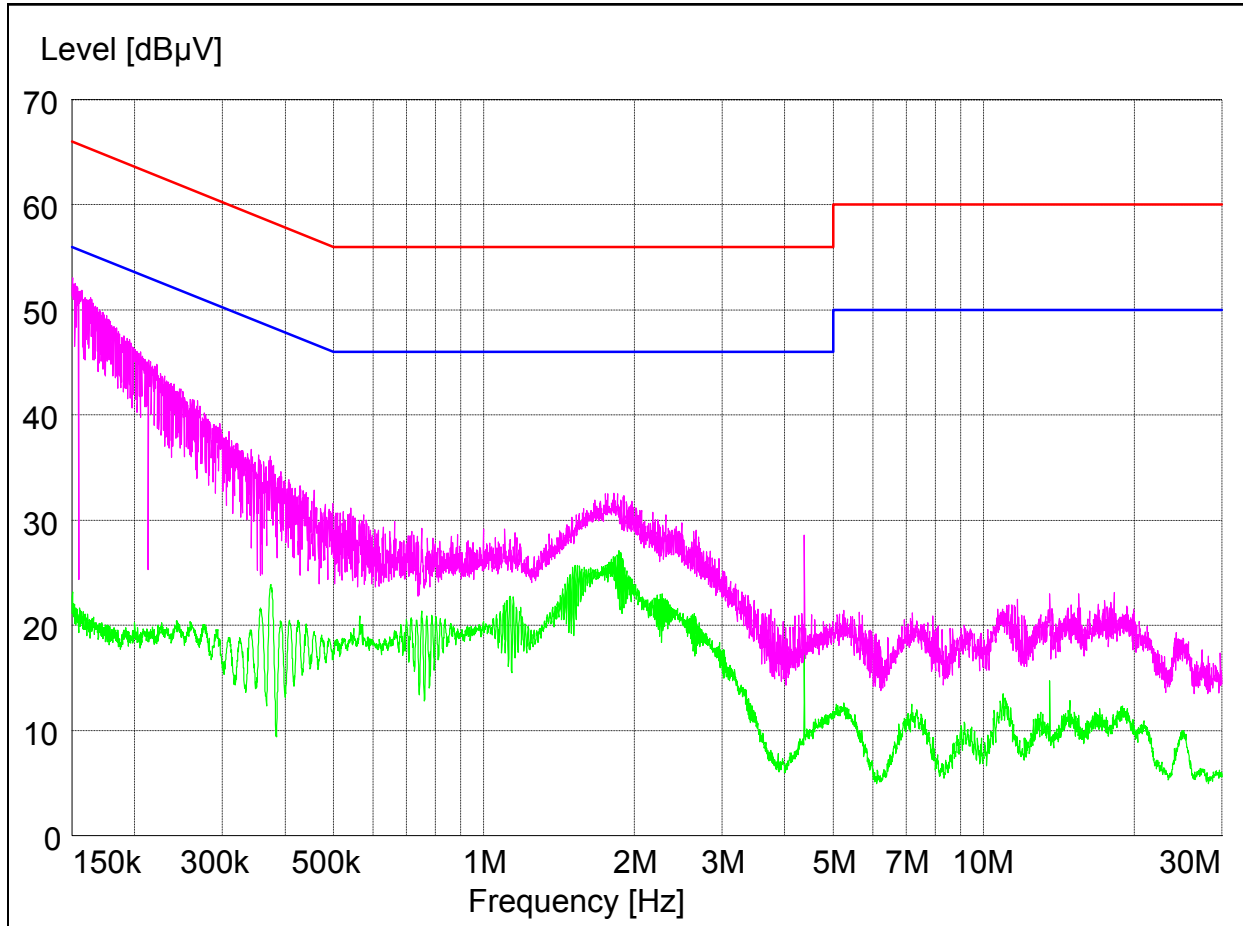

The results shown in this test report refer only to the sample(s) tested unless otherwise stated. This test report cannot be reproduced, except in full, without prior written permission of the Company.

Test mode : (Neutral)

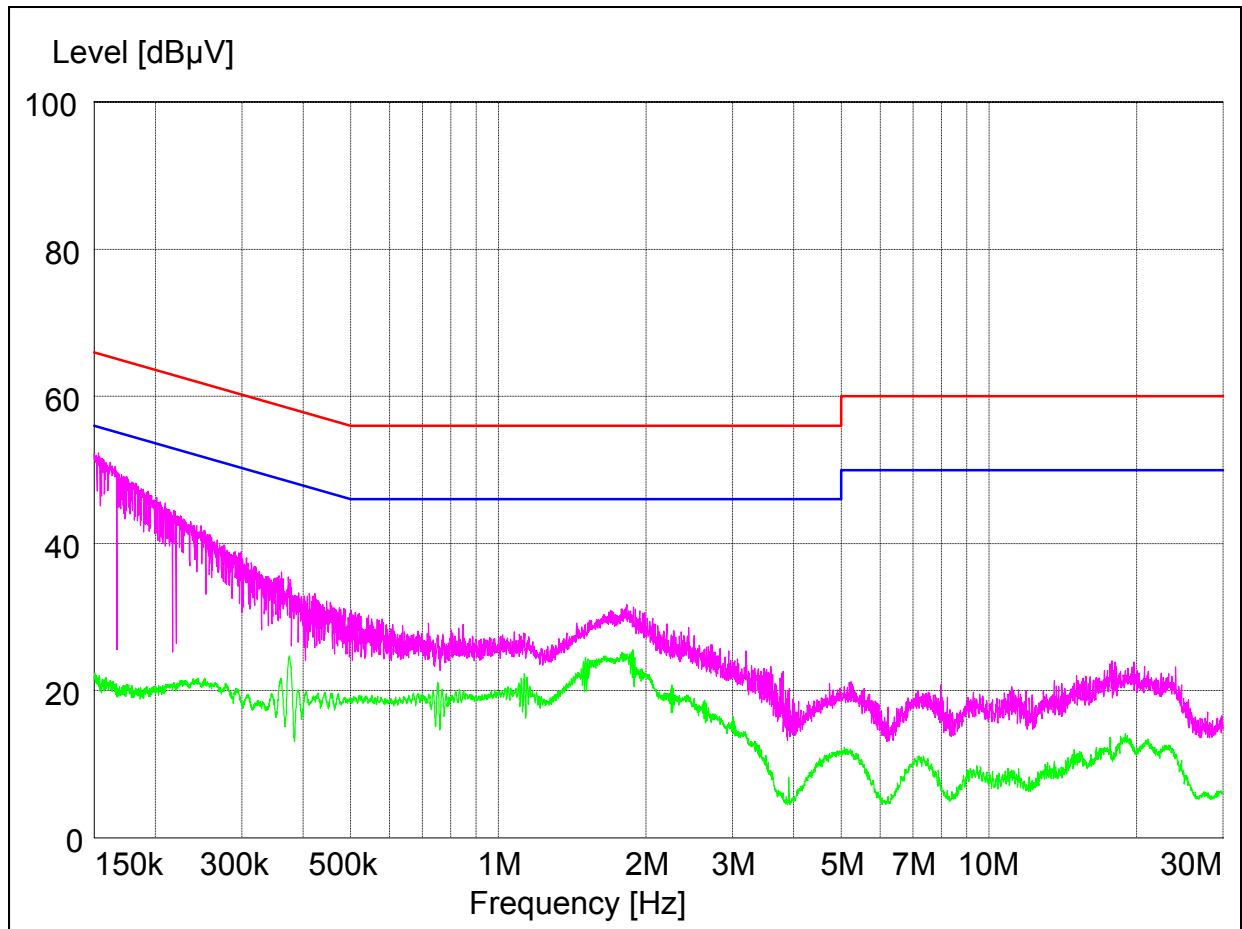

The results shown in this test report refer only to the sample(s) tested unless otherwise stated. This test report cannot be reproduced, except in full, without prior written permission of the Company.