

TEST REPORT

of

FCC Part 15 Subpart B&C §15.247/RSS-210 Issue 7, RSS-Gen Issue 2

FCC ID/IC Certification: A3LWEP301/649E-WEP301

Equipment Under Test : Bluetooth Mono Headset
Model Name : WEP301
Serial No. : N / A
Applicant : SAMSUNG ELECTRONICS CO.,LTD.
Manufacturer : SAMSUNG ELECTRONICS CO.,LTD.
Date of Test(s) : 2009.06.04 ~ 2009.06.11
Date of Issue : 2009.06.11

In the configuration tested, the EUT complied with the standards specified above.

Tested By:



Date

2009.06.11

Duke Ko

Approved By



Date

2009.06.11

Charles Kim

The results shown in this test report refer only to the sample(s) tested unless otherwise stated. This test report cannot be reproduced, except in full, without prior written permission of the Company.

INDEX

<u>Table of Contents</u>	Page
1. General Information -----	3
2. Transmitter AC Power Line Conducted Emission-----	7
3. Receiver AC Power Line Conducted Emission-----	12
4. Transmitter Radiated Spurious Emissions and Conducted Spurious Emission-----	16
5. Receiver Radiated Spurious Emission-----	29
6. 20dB Bandwidth and 99% BW-----	31
7. Maximum Peak Output Power -----	39
8. Hopping Channel Separation -----	44
9. Number of Hopping Frequency -----	47
10. Time of Occupancy(Dwell Time) -----	51
11. Antenna Requirement -----	58
12. RF Exposure Evaluation -----	59

The results shown in this test report refer only to the sample(s) tested unless otherwise stated. This test report cannot be reproduced, except in full, without prior written permission of the Company.

1. General Information

1.1. Testing Laboratory

SGS Testing Korea Co., Ltd.
 - 705, Dongchun-Dong Sooji-Gu, Yongin-Shi, Kyungki-Do, South Korea.
www.electrolab.kr.sgs.com

Telephone : +82 +31 428 5700
 FAX : +82 +31 427 2371

1.2. Details of Applicant

Applicant : SAMSUNG ELECTRONICS CO.,LTD.
 Address : 416, Maetan-dong, Yeongtong-gu, Suwon-si, Gyeonggi-do, Korea
 Contact Person : Kim, Jin Kyeong
 Phone No. : +82 +31 301 4187
 Fax No. : +82 +31 279 7609

1.3. Description of EUT

Kind of Product	Bluetooth Mono Headset
Model Name	WEP301
Serial Number	N / A
Power Supply	DC 3.7 V (Li-poly Battery)
Frequency Range	2402 ~ 2480 MHz
Modulation Technique	GFSK, $\pi/4$ DQPSK, 8DPSK
Number of Channels	79
Operating Conditions	-20 ~ 50 °C
Antenna Type	Integral Type (Chip Antenna)
Antenna Gain	0.63 dBi
H/W Version	REV1.1
S/W Version	WEP301_SW01

The results shown in this test report refer only to the sample(s) tested unless otherwise stated. This test report cannot be reproduced, except in full, without prior written permission of the Company.

1.5. Information about the FHSS characteristics:

1.5.1. Pseudorandom Frequency Hopping Sequence

The channel is represented by a pseudo-random hopping sequence hopping through the 79 RF channels. The hopping sequence is unique for the piconet and is determined by the Bluetooth device address of the master; the phase in the hopping sequence is determined by the Bluetooth clock of the master. The channel is divided into time slots where each slot corresponds to an RF hop frequency. Consecutive hops correspond to different RF hop frequencies. The nominal hop rate is 1600 hops/s.

1.5.2. Equal Hopping Frequency Use

All Bluetooth units participating in the piconet are time and hop-synchronized to the channel.

1.5.3. System Receiver Input Bandwidth

Each channel bandwidth is 1MHz

1.6. Test Equipment List

EQUIPMENT	MANUFACTURER	MODEL	CAL DUE.
Signal Generator	Rohde & Schwarz	SMR40	Jan. 21, 2010
Spectrum Analyzer	Rohde & Schwarz	FPS40	Oct. 01, 2009
Bluetooth Tester	TESOM	TC-3000B	Oct. 10, 2009
Directional Coupler	Narda	4226-20	Jan .06, 2010
Preamplifier	H.P	8447F	Jul. 03, 2009
Preamplifier	Agilent	8449B	Apr. 01, 2010
High Pass Filter	Wainwright	WHK3.0/18G-10SS	Oct. 01, 2009
Test Receiver	R & S	ESVS10	Jan. 17, 2010
Ultra-Broadband Antenna	R & S	HL562	Oct. 02, 2009
Horn Antenna	R & S	HF 906	Nov. 13, 2009
Anechoic Chamber	SY Corporation	L × W × H (9.6 m×6.4 m×6.6 m)	Jan. 31, 2010
Two-Line V-Network	R & S	ENV216	Jan. 07, 2010
Test Receiver	R & S	ESHS10	Jul. 21, 2009
Anechoic Chamber	SY Corporation	L x W x H (6.5 m x 3.5 m x 3.5 m)	N.C.R

The results shown in this test report refer only to the sample(s) tested unless otherwise stated. This test report cannot be reproduced, except in full, without prior written permission of the Company.

1.7. Summary of Test Results

The EUT has been tested according to the following specifications:

APPLIED STANDARD:FCC Part15, RSS-210,RSS-Gen			
Section in FCC 15	Section in RSS-210 RSS-Gen	Test Item	Result
15.207	RSS-Gen 7.2.2	Transmitter AC Power Line Conducted Emission	Complied
15.107	RSS-Gen 7.2.2	Receiver AC Power Line Conducted Emission	Complied
15.205(a) 15.209 15.247(d)	A8.5	Transmitter Radiated Spurious Emissions Conducted Spurious Emission	Complied
15.109(a)	RSS-Gen 6	Receiver Radiated Spurious Emission	Complied
15.247(a)(1)	A8.1(1)	20 dB Bandwidth and 99% BW	Complied
15.247(b)(1)	A8.4(2)	Maximum Peak Output Power	Complied
15.247(a)(1)	A8.1(2)	Frequency Separation	Complied
15.247(a)(1)(iii)	A8.1(4)	Number of Hopping Frequency	Complied
15.247(a)(1)(iii)	A8.1(4)	Time of Occupancy (Dwell Time)	Complied
15.247(f)	A8.3(2)	Power Spectral Density	Complied
15.247(i) 1.1307(b)(1)	RSS-Gen 5.5/ RSS-102	Maximum Permissible Exposure (Exposure of Humans to RF Fields)	Complied

The results shown in this test report refer only to the sample(s) tested unless otherwise stated. This test report cannot be reproduced, except in full, without prior written permission of the Company.

1.8. Conclusion of worst-case and operation mode

The EUT has three type of modulation (GFSK, $\pi/4$ DQPSK and 8DPSK). Each output power as following:

Modulation Type	Ouput power(dBm)	Output power(mW)	Symbol rate
GFSK(2402 MHz)	2.42	1.75	1Mbps
$\pi/4$ DQPSK(2402 MHz)	1.75	1.50	2Mbps
8DPSK(2402 MHz)	2.11	1.63	3Mbps

Therefore all applicable requirements were tested to the two type of higher output power modulation (GFSK and 8DPSK) at low channel (2402 MHz).

The field strength of spurious emission was measured in three orthogonal EUT positions(X-axis, Y-axis and Z-axis). Worst case is Z-axis.

1.9 Test report revision

Revision	Report number	Description
0	F690501/RF-RTL003162	Initial

The results shown in this test report refer only to the sample(s) tested unless otherwise stated. This test report cannot be reproduced, except in full, without prior written permission of the Company.

2. Transmitter AC Power Line Conducted Emission

2.1. Test Setup

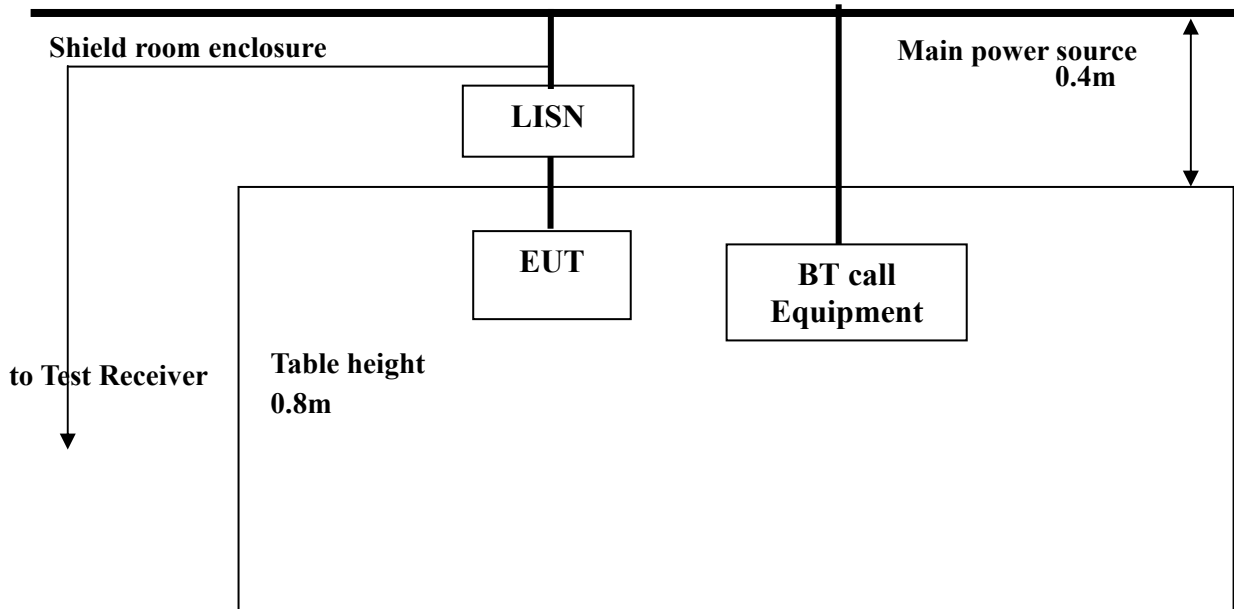

2.2. Limit

According to §15.207(a) for an intentional radiator that is designed to be connected to the public utility (AC) power line, the radio frequency voltage that is conducted back onto the AC power line on any frequency or frequencies, within the band 150 kHz to 30 MHz, shall not exceed the limits in the following table, as measured using a 50 uH/50 ohm line impedance stabilization network(LISN).

Compliance with the provision of this paragraph shall on the measurement of the radio frequency voltage between each power line and ground at the power terminal. The lower applies at the boundary between the frequency ranges.

Frequency of Emission (MHz)	Conducted limit (dB μ V)	
	Quasi-peak	Average
0.15 – 0.50	66-56*	56-46*
0.50 – 5.00	56	46
5.00 – 30.0	60	50

* Decreases with the logarithm of the frequency.

The results shown in this test report refer only to the sample(s) tested unless otherwise stated. This test report cannot be reproduced, except in full, without prior written permission of the Company.

2.3. Test Procedures

Radiated emissions from the EUT were measured according to the dictates of ANSI C63.4:2003

1. The test procedure is performed in a 6.5m × 3.6m × 3.6m (L×W×H) shielded room. The EUT along with its peripherals were placed on a 1.0m(W)× 1.5m(L) and 0.8m in height wooden table and the EUT was adjusted to maintain a 0.4 meter space from a vertical reference plane.
2. The EUT was connected to power mains through a line impedance stabilization network (LISN) which provides 50 ohm coupling impedance for measuring instrument and the chassis ground was bounded to the horizontal ground plane of shielded room.
3. All peripherals were connected to the second LISN and the chassis ground also bounded to the horizontal ground plane of shielded room.
4. The excess power cable between the EUT and the LISN was bundled. The power cables of peripherals were unbundled. All connecting cables of EUT and peripherals were moved to find the maximum emission.

The results shown in this test report refer only to the sample(s) tested unless otherwise stated. This test report cannot be reproduced, except in full, without prior written permission of the Company.

2.4. Test Results(Worst case configuration_GFSK mode)

The following table shows the highest levels of conducted emissions on both phase of Hot and Neutral line.

Ambient temperature : 24 °C
 Relative humidity : 47 % R.H.

Frequency range : 0.15 MHz – 30 MHz
 Measured Bandwidth : 9 kHz

FREQ. (MHz)	LEVEL(dBuV)		LINE	LIMIT(dBuV)		MARGIN(dB)	
	Q-Peak	Average		Q-Peak	Average	Q-Peak	Average
0.21	22.10	9.70	H	63.21	53.21	41.11	43.51
0.38	21.80	7.90	H	58.28	48.28	36.48	40.38
2.40	14.50	4.40	H	56.00	46.00	41.50	41.60
13.56	20.00	16.70	H	60.00	50.00	40.00	33.30
21.92	10.00	4.10	H	60.00	50.00	50.00	45.90
25.06	24.90	20.40	H	60.00	50.00	35.10	29.60
0.23	18.20	5.70	N	62.45	52.45	44.25	46.75
0.46	20.50	6.90	N	56.69	46.69	36.19	39.79
1.91	20.20	13.90	N	56.00	46.00	35.80	32.10
13.56	20.40	16.10	N	60.00	50.00	39.60	33.90
21.93	10.10	4.30	N	60.00	50.00	49.90	45.70
25.06	25.20	19.10	N	60.00	50.00	34.80	30.90

Note ;

Line (H) : Hot

Line (N) : Neutral

The results shown in this test report refer only to the sample(s) tested unless otherwise stated. This test report cannot be reproduced, except in full, without prior written permission of the Company.

Plot of Conducted Power line

Test mode : (Hot)

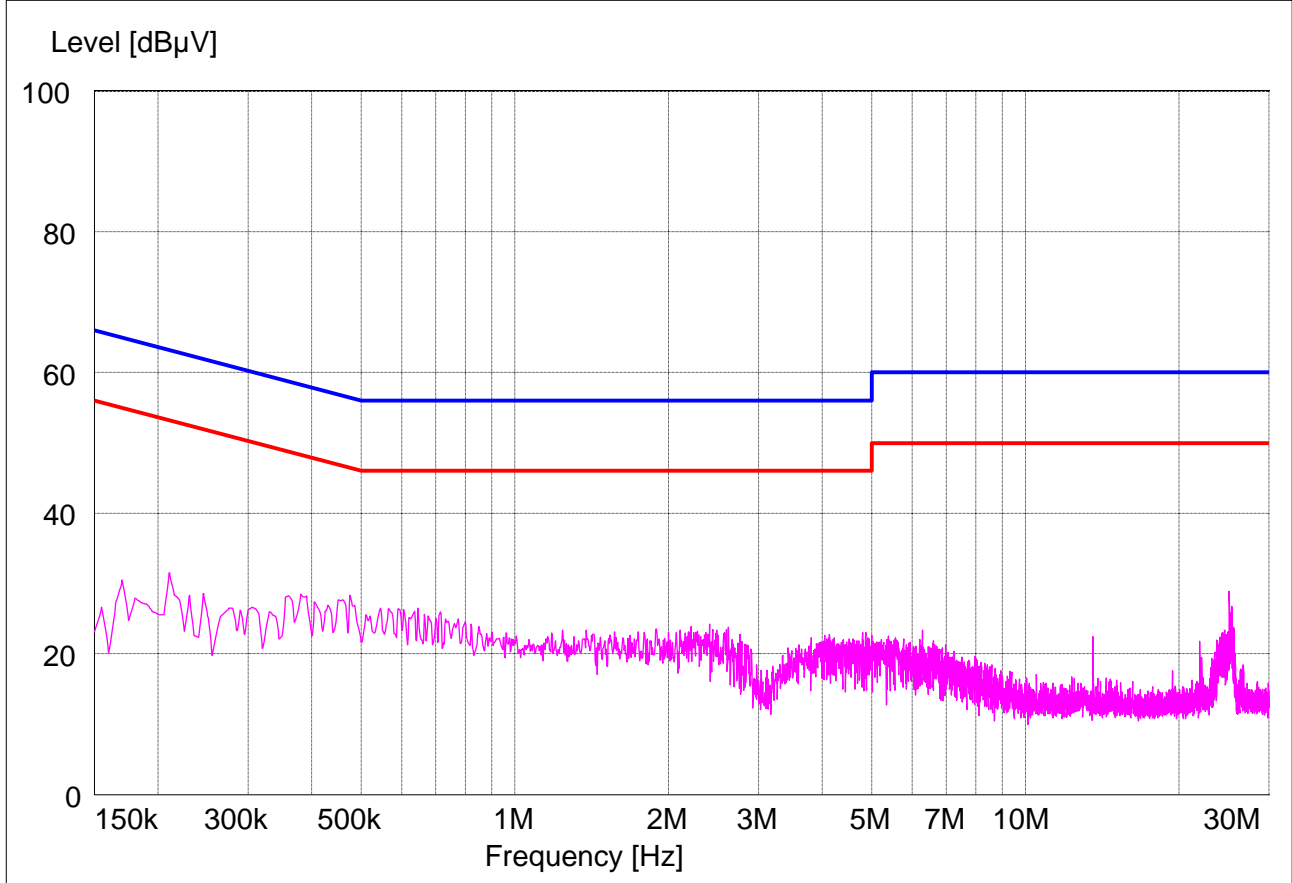

The results shown in this test report refer only to the sample(s) tested unless otherwise stated. This test report cannot be reproduced, except in full, without prior written permission of the Company.

Test mode : (Neutral)

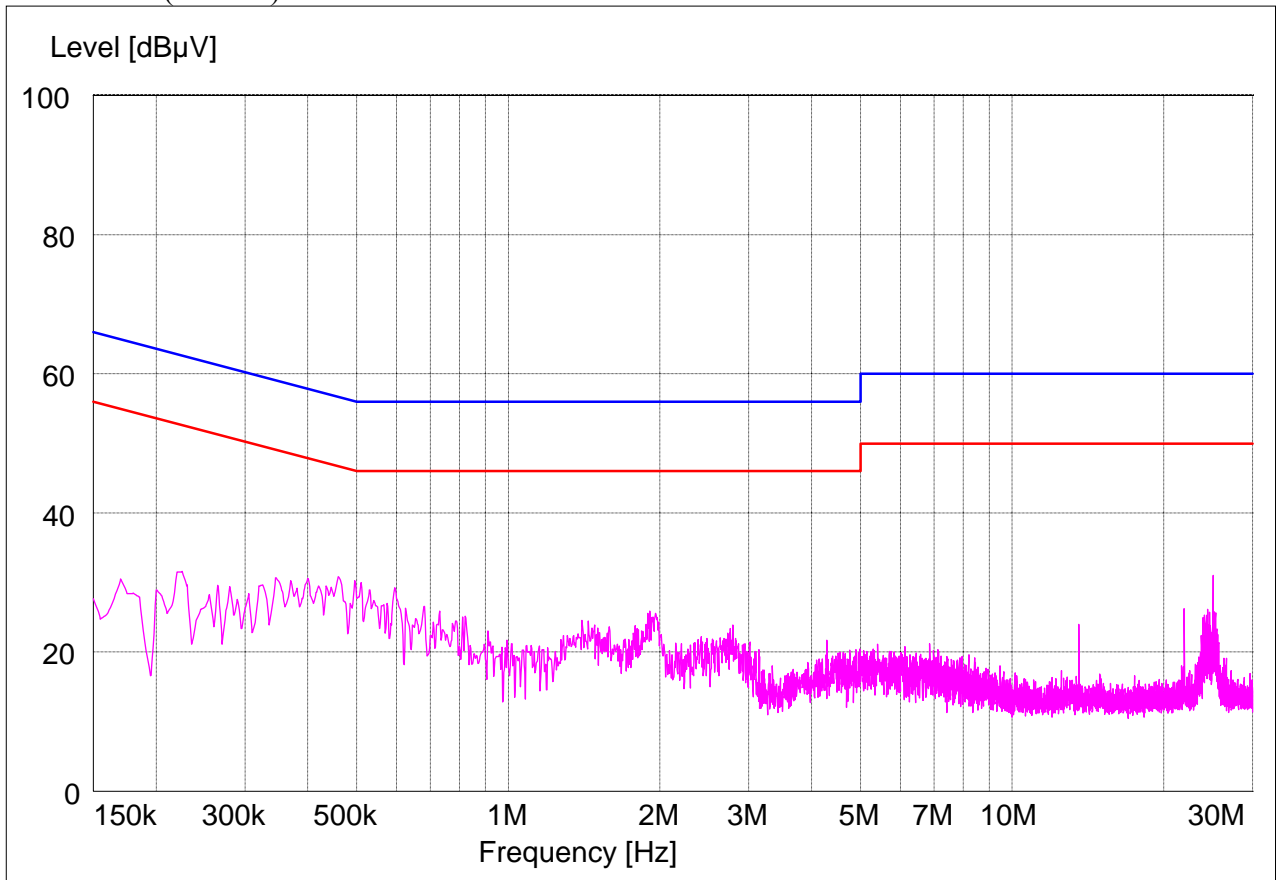

The results shown in this test report refer only to the sample(s) tested unless otherwise stated. This test report cannot be reproduced, except in full, without prior written permission of the Company.

3. Receiver AC Power Line Conducted Emission

3.1. Test Setup- Same as clause 2.1.

3.2. Limit

According to §15.107(a) Except for Class A digital devices, for equipment that is designed to be connected to the public utility (AC) power line, the radio frequency voltage that is conducted back onto the AC power line on any frequency or frequencies within the band 150 kHz to 30 MHz shall not exceed the limits in the following table, as measured using a 50 μ H/50 ohms line impedance stabilization network (LISN). Compliance with the provisions of this paragraph shall be based on the measurement of the radio frequency voltage between each power line and ground at the power terminal. The lower limit applies at the band edges.

Frequency of Emission (MHz)	Conducted limit (dB μ V)	
	Quasi-peak	Average
0.15 – 0.50	66-56*	56-46*
0.50 – 5.00	56	46
5.00 – 30.0	60	50

* Decreases with the logarithm of the frequency.

The results shown in this test report refer only to the sample(s) tested unless otherwise stated. This test report cannot be reproduced, except in full, without prior written permission of the Company.

3.3. Test Procedures- Same as clause 2.3.

3.4. Test Results (Worst case configuration_GFSK mode)

The following table shows the highest levels of conducted emissions on both phase of Hot and Neutral line;
Addition,

Ambient temperature : 24 °C
Relative humidity : 47 % R.H.

Frequency range : 0.15 MHz – 30 MHz
Measured Bandwidth : 9 kHz

FREQ. (MHz)	LEVEL(dBuV)		LINE	LIMIT(dBuV)		MARGIN(dB)	
	Q-Peak	Average		Q-Peak	Average	Q-Peak	Average
0.21	23.20	6.70	H	63.41	53.41	40.21	46.71
0.39	20.00	5.40	H	58.06	48.06	38.06	42.66
1.63	15.60	4.20	H	56.00	46.00	40.40	41.80
2.38	14.80	3.90	H	56.00	46.00	41.20	42.10
24.13	18.20	7.90	H	60.00	50.00	41.80	42.10
25.06	19.90	13.80	H	60.00	50.00	40.10	36.20
0.17	7.60	2.60	N	64.96	54.96	57.36	52.36
1.37	16.30	11.40	N	56.00	46.00	39.70	34.60
1.90	20.10	14.90	N	56.00	46.00	35.90	31.10
13.56	19.50	15.60	N	60.00	50.00	40.50	34.40
24.11	14.90	7.40	N	60.00	50.00	45.10	42.60
25.06	24.30	18.50	N	60.00	50.00	35.70	31.50

Note ;

Line (H) : Hot

Line (N) : Neutral

The results shown in this test report refer only to the sample(s) tested unless otherwise stated. This test report cannot be reproduced, except in full, without prior written permission of the Company.

Plot of Conducted Power line

Test mode : (Hot)

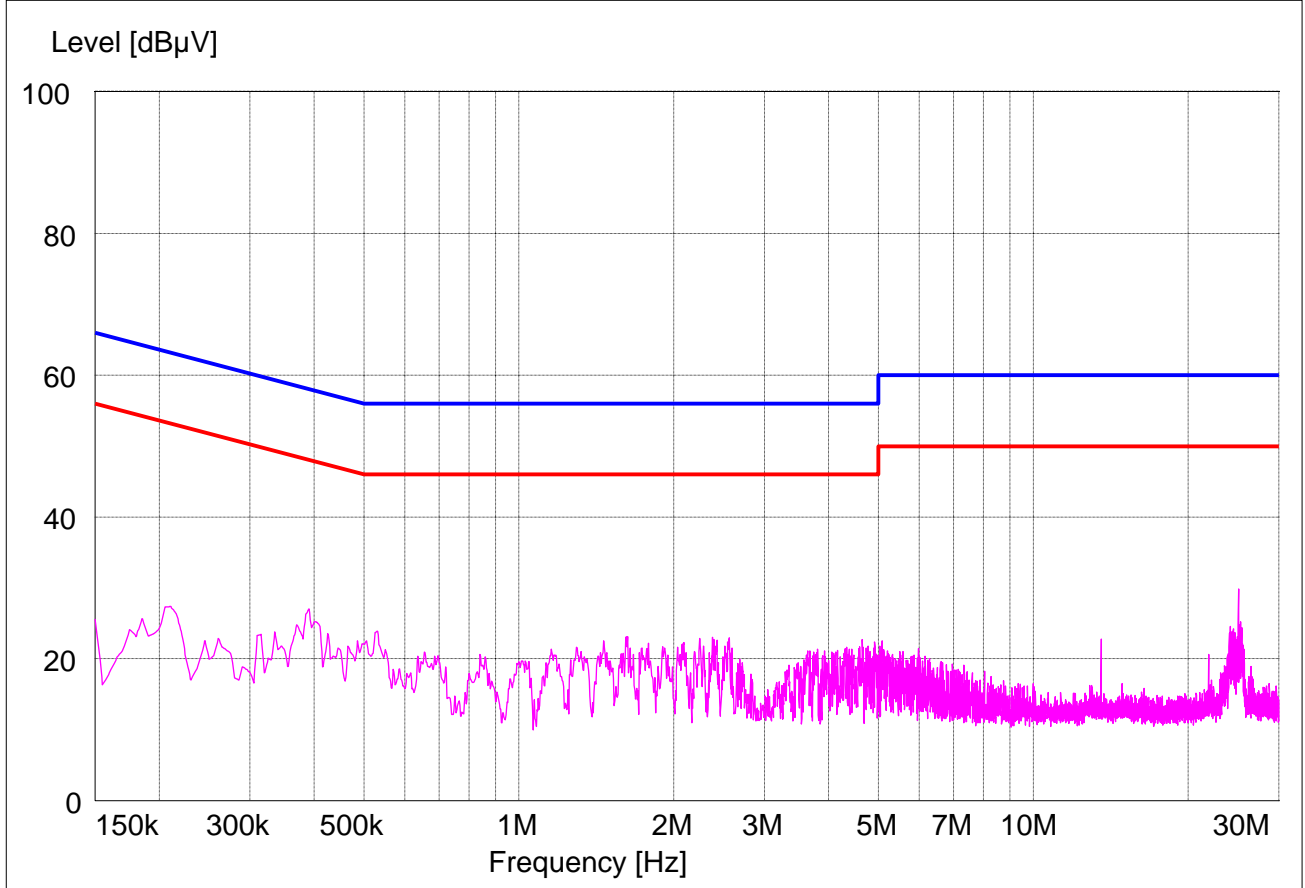

The results shown in this test report refer only to the sample(s) tested unless otherwise stated. This test report cannot be reproduced, except in full, without prior written permission of the Company.

Test mode : (Neutral)

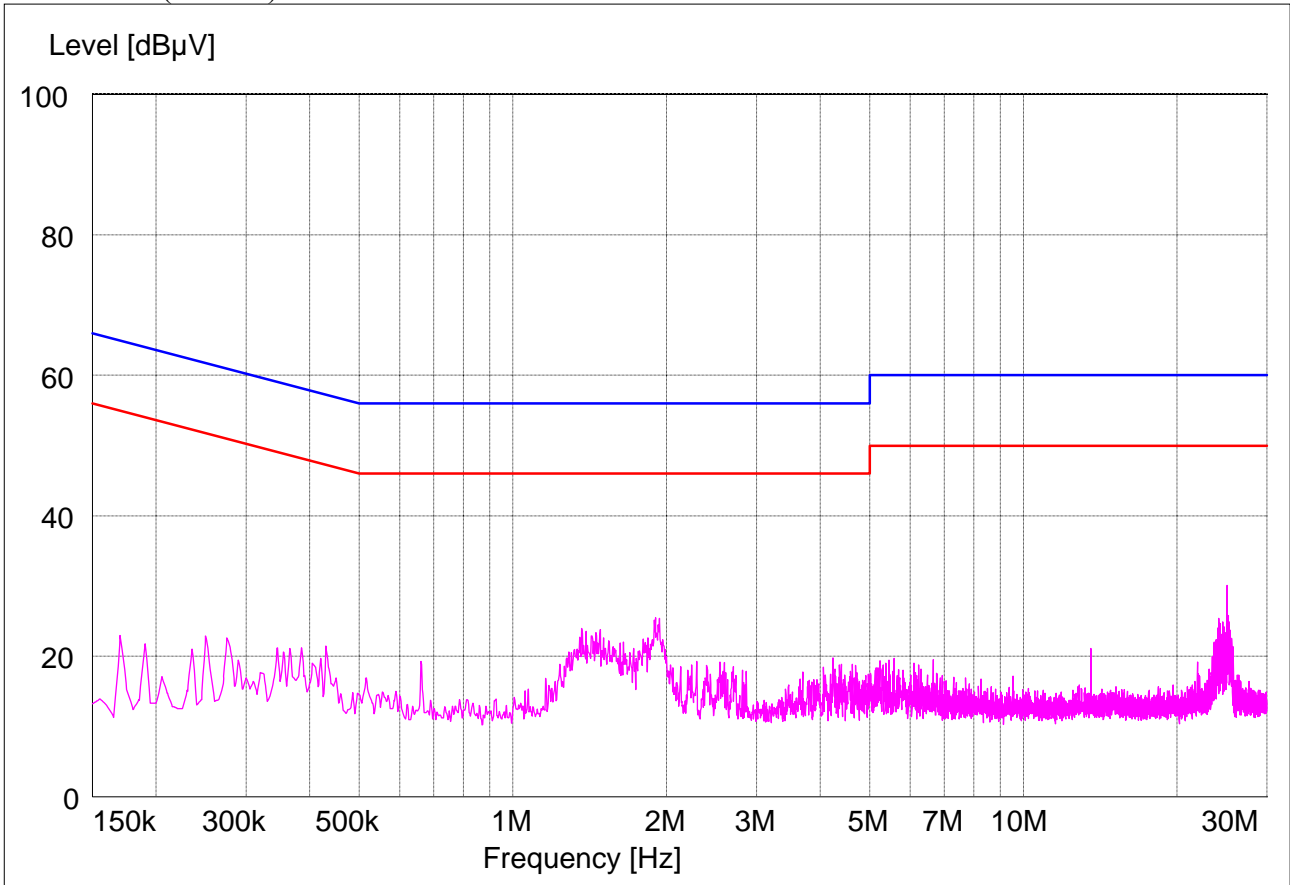

The results shown in this test report refer only to the sample(s) tested unless otherwise stated. This test report cannot be reproduced, except in full, without prior written permission of the Company.

4. Transmitter Radiated Spurious Emissions and Conducted Spurious Emission

4.1. Test Setup

4.1.1. Transmitter Radiated Spurious Emissions

The diagram below shows the test setup that is utilized to make the measurements for emission from 30 MHz to 1 GHz Emissions.

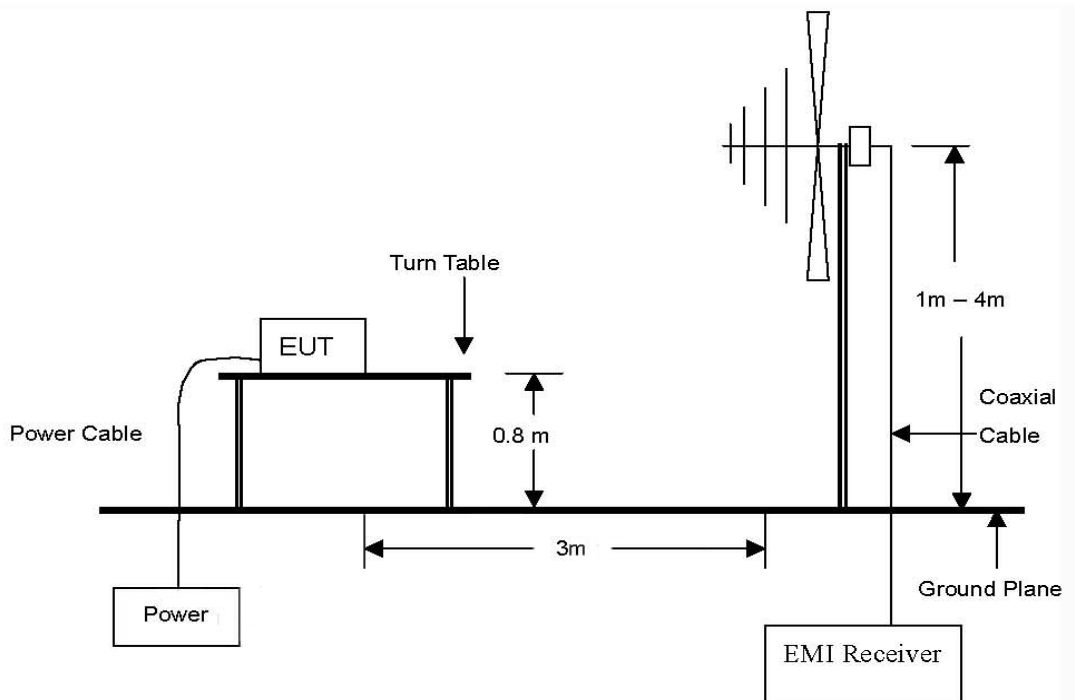

The diagram below shows the test setup that is utilized to make the measurements for emission from 1 GHz to 24 GHz Emissions.

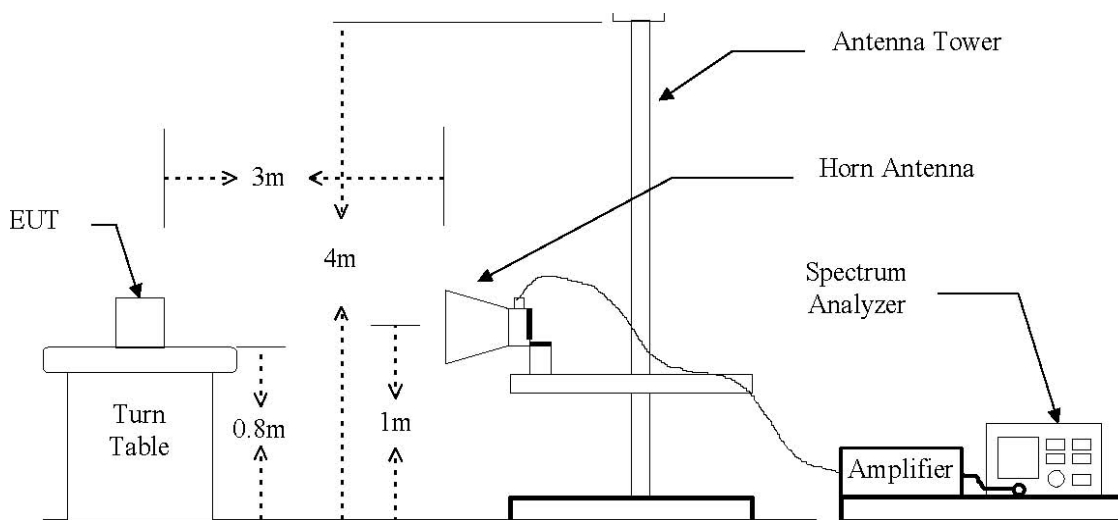

The results shown in this test report refer only to the sample(s) tested unless otherwise stated. This test report cannot be reproduced, except in full, without prior written permission of the Company.

4.1.2. Conducted Spurious Emission

4.1. Test Setup

4.1.1. Conducted Spurious Emissions

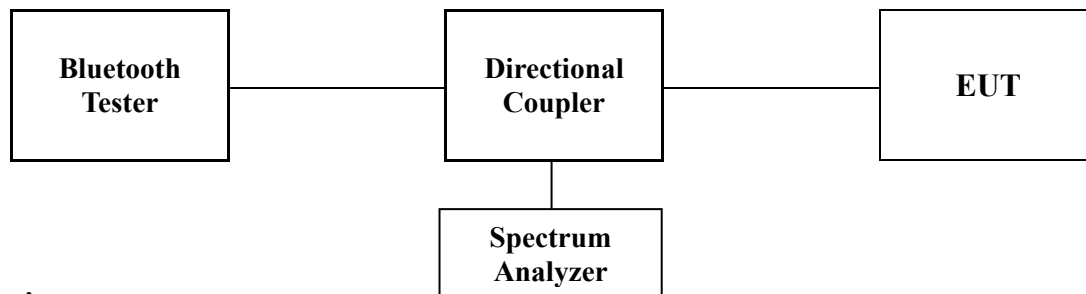

4.2. Limit

According to §15.247(d), in any 100 kHz bandwidth outside the frequency band in which the spread spectrum or digitally modulated intentional radiator is operating, the radio frequency power that is produced by the intentional radiator shall be at least 20 dB below that in the 100 kHz bandwidth within the band that contains the highest level of the desired power, based on either an RF conducted or a radiated measurement, provided the transmitter demonstrates compliance with the peak conducted power limits. If the transmitter complies with the conducted power limits based on the use of RMS averaging over a time interval, as permitted under paragraph(b)(3) of this section, the attenuation required under this paragraph shall be 30 dB instead of 20 dB. Attenuation below the general limits specified in section §15.209(a) is not required. In addition, radiated emission which in the restricted band, as define in section §15.205(a), must also comply the radiated emission limits specified in section §15.209(a) (see section §15.205(c))

According to § 15.209(a), Except as provided elsewhere in this Subpart, the emissions from an intentional radiator shall not exceed the field strength levels specified in the following table :

Frequency (MHz)	Distance (Meters)	Field Strength (dB μ V/m)	Field Strength (μ V/m)
30 - 88	3	40.0	100
88 – 216	3	43.5	150
216 – 960	3	46.0	200
Above 960	3	54.0	500

The results shown in this test report refer only to the sample(s) tested unless otherwise stated. This test report cannot be reproduced, except in full, without prior written permission of the Company.

4.3. Test Procedures

Radiated emissions from the EUT were measured according to the dictates of ANSI C63.4:2003

4.3.1. Test Procedures for Radiated Spurious Emissions

1. The EUT was placed on the top of a rotating table 0.8 meters above the ground at a 3 meter anechoic chamber test site. The table was rotated 360 degrees to determine the position of the highest radiation.
2. During performing radiated emission below 1 GHz, the EUT was set 3 meters away from the interference receiving antenna, which was mounted on the top of a variable-height antenna tower. During performing radiated emission above 1 GHz, the EUT was set 3 meter away from the interference-receiving antenna.
3. The antenna is a broadband antenna, and its height is varied from one meter to four meters above the ground to determine the maximum value of the field strength. Both horizontal and vertical polarizations of the antenna are set to make the measurement.
4. For each suspected emission, the EUT was arranged to its worst case and then the antenna was tuned to heights from 1 meter to 4 meters and the table was turned from 0 degrees to 360 degrees to find the maximum reading.
5. The test-receiver system was set to Peak Detect Function and Specified Bandwidth with Maximum Hold Mode.
6. If the emission level of the EUT in peak mode was 10 dB lower than the limit specified, then testing could be stopped and the peak values of the EUT would be reported. Otherwise the emissions that did not have 10 dB margin would be re-tested one by one using peak, quasi-peak or average method as specified and then reported in a data sheet.

NOTE ;

1. The resolution bandwidth and video bandwidth of test receiver/spectrum analyzer is 120 kHz for Peak detection (PK) and Quasi-peak detection (QP) at frequency below 1 GHz.
2. The resolution bandwidth and video bandwidth of test receiver/spectrum analyzer is 1MHz for Peak detection and frequency above 1 GHz.
3. The resolution bandwidth of test receiver/spectrum analyzer is 1 MHz and the video bandwidth is 10 Hz for Average detection (AV) at frequency above 1 GHz.

4.3.2. Test Procedures for Conducted Spurious Emissions

1. The transmitter output was connected to the spectrum analyzer.
2. The bandwidth of the fundamental frequency was measured with the spectrum analyzer using RBW=100 kHz, VBW=100 kHz.

The results shown in this test report refer only to the sample(s) tested unless otherwise stated. This test report cannot be reproduced, except in full, without prior written permission of the Company.

4.4. Test Results

Ambient temperature : 24 °C
 Relative humidity : 47 % R.H.

4.4.1. Spurious Radiated Emission (Worst case configuration_GFSK mode)

The frequency spectrum from 30 MHz to 1000 MHz was investigated. Emission levels are not reported much lower than the limits by over 30 dB. All reading values are quasi-peak values.

Radiated Emissions			Ant	Correction Factors		Total	FCC Limit	
Frequency (MHz)	Reading (dBuV)	Detect Mode	Pol.	AF (dB/m)	CL (dB)	Actual (dBuV/m)	Limit (dBuV/m)	Margin (dB)
265.225	15.07	Q.P.	H	9.94	1.83	26.84	46.00	19.16
308.875	14.32	Q.P.	H	11.15	1.98	27.44	46.00	18.56
762.350	7.09	Q.P.	H	19.44	3.10	29.63	46.00	16.37
856.925	14.03	Q.P.	H	20.43	3.30	37.76	46.00	8.24
912.700	7.24	Q.P.	H	21.08	3.44	31.76	46.00	14.24
Above 1000.000	Not detected	-	-	-	-	-	-	-

Remark:

1. All spurious emission at channels are almost the same below 1 GHz, so that the channel was chosen at representative in final test.
2. “*” means the restricted band.
3. Actual = Reading + AF + CL
4. The emission levels above 1000 MHz are very lower than the limit by over 30 dB.

The results shown in this test report refer only to the sample(s) tested unless otherwise stated. This test report cannot be reproduced, except in full, without prior written permission of the Company.

4.4.2. Spurious Radiated Emission

The frequency spectrum above 1000 MHz was investigated. Emission levels are not reported much lower than the limits by over 30 dB.

Operating Mode: GFSK

A. Low Channel (2402 MHz)

Radiated Emissions			Ant	Correction Factors		Total	FCC Limit	
Frequency (MHz)	Reading (dBuV)	Detect Mode	Pol.	AF (dB/m)	CL (dB)	Actual (dBuV/m)	Limit (dBuV/m)	Margin (dB)
*2390.000	28.73	Peak	H	28.05	5.32	62.10	74.00	11.90
*2390.000	15.92	Average	H	28.05	5.32	49.29	54.00	4.71

Radiated Emissions			Ant	Correction Factors		Total	FCC Limit	
Frequency (MHz)	Reading (dBuV)	Detect Mode	Pol.	AF (dB/m)	Amp Gain+CL (dB)	Actual (dBuV/m)	Limit (dBuV/m)	Margin (dB)
4804.113	47.67	Peak	H	32.95	-36.70	43.92	74.00	30.08
Above 4900.000	Not detected	-	-	-	-	-	-	-

B. Middle Channel (2441 MHz)

Radiated Emissions			Ant	Correction Factors		Total	FCC Limit	
Frequency (MHz)	Reading (dBuV)	Detect Mode	Pol.	AF (dB/m)	Amp Gain+CL (dB)	Actual (dBuV/m)	Limit (dBuV/m)	Margin (dB)
4881.925	48.68	Peak	H	33.17	-36.69	45.16	74.00	28.84
Above 4900.000	Not detected	-	-	-	-	-	-	-

The results shown in this test report refer only to the sample(s) tested unless otherwise stated. This test report cannot be reproduced, except in full, without prior written permission of the Company.

C. High Channel (2480 MHz)

Radiated Emissions			Ant	Correction Factors		Total	FCC Limit	
Frequency (MHz)	Reading (dBuV)	Detect Mode	Pol.	AF (dB/m)	CL (dB)	Actual (dBuV/m)	Limit (dBuV/m)	Margin (dB)
*2483.500	28.53	Peak	H	28.18	5.34	62.05	74.00	11.95
*2483.500	16.99	Average	H	28.18	5.34	50.51	54.00	3.49

Radiated Emissions			Ant	Correction Factors		Total	FCC Limit	
Frequency (MHz)	Reading (dBuV)	Detect Mode	Pol.	AF (dB/m)	Amp Gain+CL (dB)	Actual (dBuV/m)	Limit (dBuV/m)	Margin (dB)
4959.925	44.05	Peak	H	33.39	-36.68	40.76	74.00	33.24
Above 5000.000	Not detected	-	-	-	-	-	-	-

Operating Mode: 8DPSK

A. Low Channel (2402 MHz)

Radiated Emissions			Ant	Correction Factors		Total	FCC Limit	
Frequency (MHz)	Reading (dBuV)	Detect Mode	Pol.	AF (dB/m)	CL (dB)	Actual (dBuV/m)	Limit (dBuV/m)	Margin (dB)
*2390.000	26.81	Peak	H	28.05	5.32	60.18	74.00	13.82
*2390.000	15.99	Average	H	28.05	5.32	49.36	54.00	4.65

Radiated Emissions			Ant	Correction Factors		Total	FCC Limit	
Frequency (MHz)	Reading (dBuV)	Detect Mode	Pol.	AF (dB/m)	Amp Gain+CL (dB)	Actual (dBuV/m)	Limit (dBuV/m)	Margin (dB)
4803.875	45.31	Peak	H	32.95	-36.70	41.56	74.00	32.44
Above 4900.000	Not detected	-	-	-	-	-	-	-

The results shown in this test report refer only to the sample(s) tested unless otherwise stated. This test report cannot be reproduced, except in full, without prior written permission of the Company.

B. Middle Channel (2441 MHz)

Radiated Emissions			Ant	Correction Factors		Total	FCC Limit	
Frequency (MHz)	Reading (dBuV)	Detect Mode	Pol.	AF (dB/m)	Amp Gain+CL (dB)	Actual (dBuV/m)	Limit (dBuV/m)	Margin (dB)
4881.550	44.67	Peak	H	33.17	-36.69	41.15	74.00	32.85
Above 4900.000	Not detected	-	-	-	-	-	-	-

C. High Channel (2480 MHz)

Radiated Emissions			Ant	Correction Factors		Total	FCC Limit	
Frequency (MHz)	Reading (dBuV)	Detect Mode	Pol.	AF (dB/m)	CL (dB)	Actual (dBuV/m)	Limit (dBuV/m)	Margin (dB)
*2483.500	28.07	Peak	H	28.18	5.34	61.59	74.00	12.41
*2483.500	17.05	Average	H	28.18	5.34	50.57	54.00	3.43

Radiated Emissions			Ant	Correction Factors		Total	FCC Limit	
Frequency (MHz)	Reading (dBuV)	Detect Mode	Pol.	AF (dB/m)	Amp Gain+CL (dB)	Actual (dBuV/m)	Limit (dBuV/m)	Margin (dB)
4959.400	43.84	Peak	H	33.39	-36.68	40.55	74.00	33.45
Above 5000.000	Not detected	-	-	-	-	-	-	-

Remarks ;

1. “*” means the restricted band.
2. Measuring frequencies from 1 GHz to the 10th harmonic of highest fundamental Frequency.
3. Radiated emissions measured in frequency above 1000 MHz were made with an instrument using peak/average detector mode.
4. Average test would be performed if the peak result were greater than the average limit.
5. Actual = Reading + AF + Amp Gain + CL

The results shown in this test report refer only to the sample(s) tested unless otherwise stated. This test report cannot be reproduced, except in full, without prior written permission of the Company.

4.4.3. Spurious RF Conducted Emissions: Plot of Spurious RF Conducted Emission

Operating Mode: GFSK

Low Channel



The results shown in this test report refer only to the sample(s) tested unless otherwise stated. This test report cannot be reproduced, except in full, without prior written permission of the Company.

Middle Channel

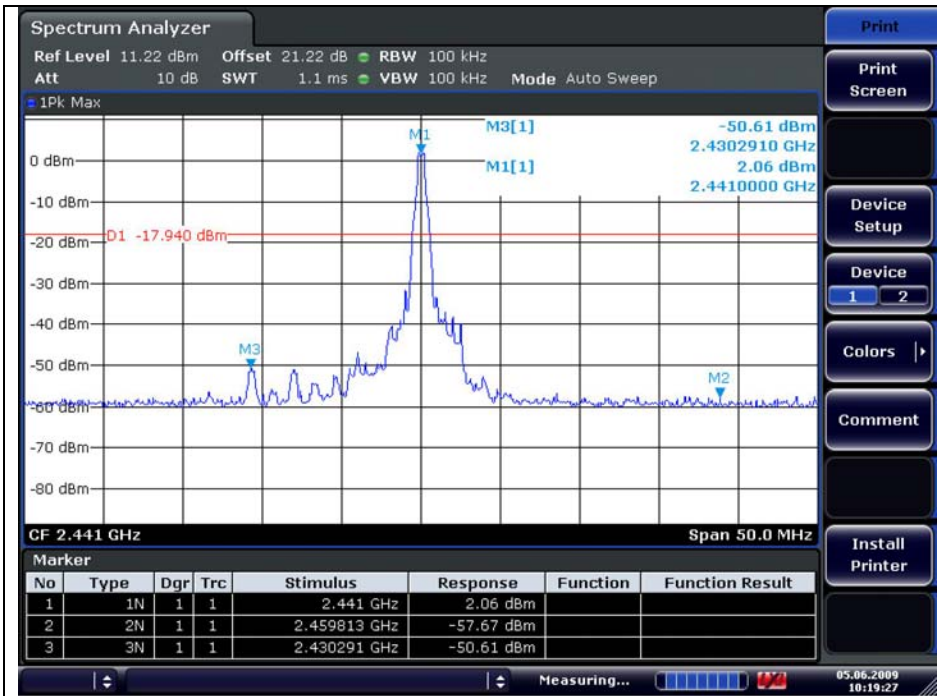

Date: 5.JUN.2009 10:19:27

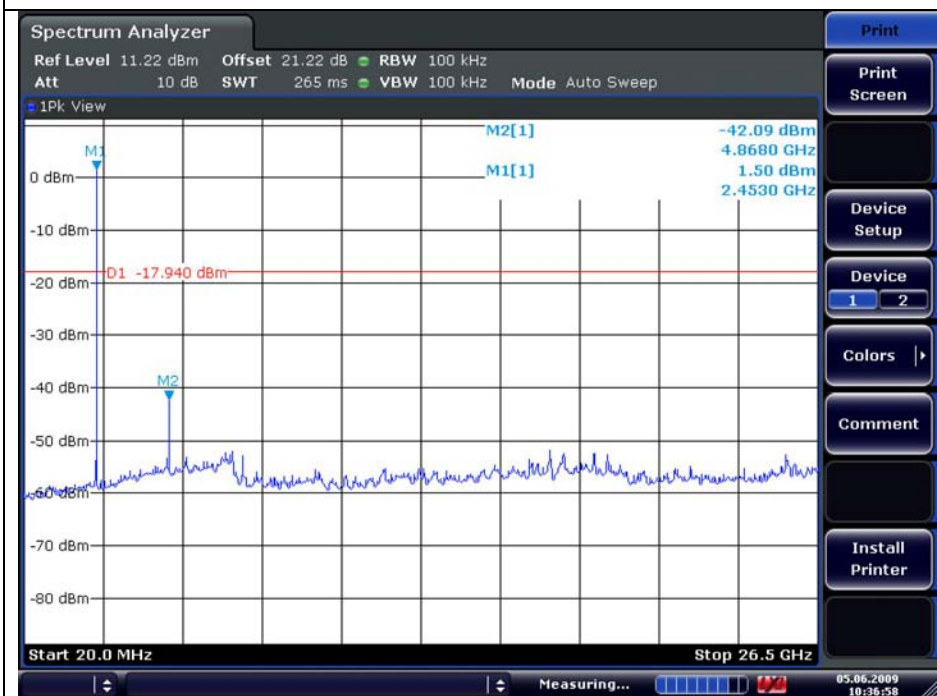

Date: 5.JUN.2009 10:36:59

The results shown in this test report refer only to the sample(s) tested unless otherwise stated. This test report cannot be reproduced, except in full, without prior written permission of the Company.

High Channel

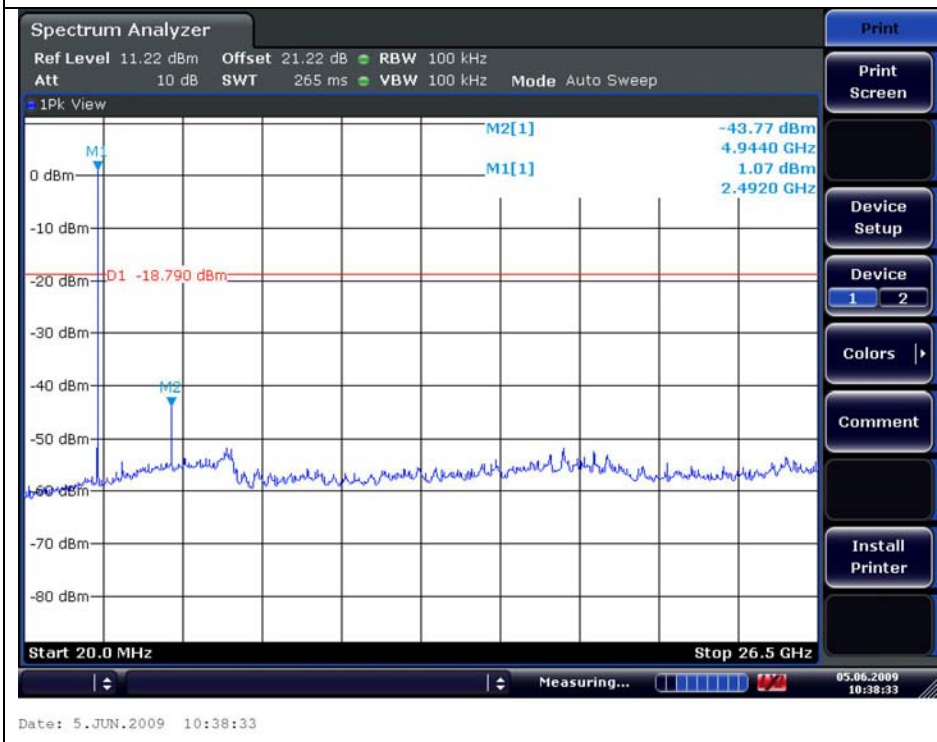
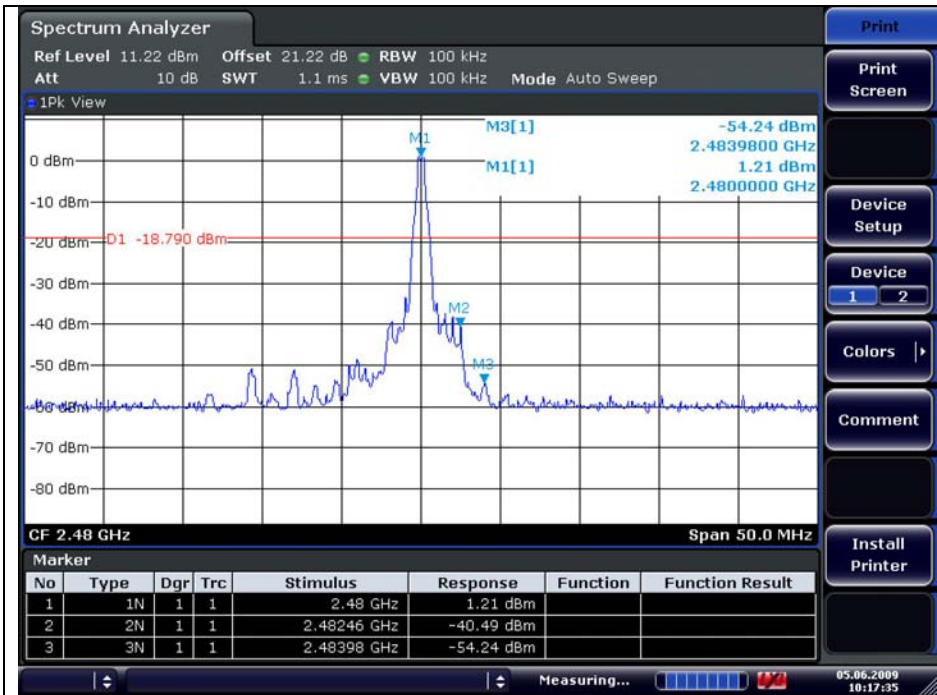

The results shown in this test report refer only to the sample(s) tested unless otherwise stated. This test report cannot be reproduced, except in full, without prior written permission of the Company.

Operating Mode: 8DPSK

Low Channel

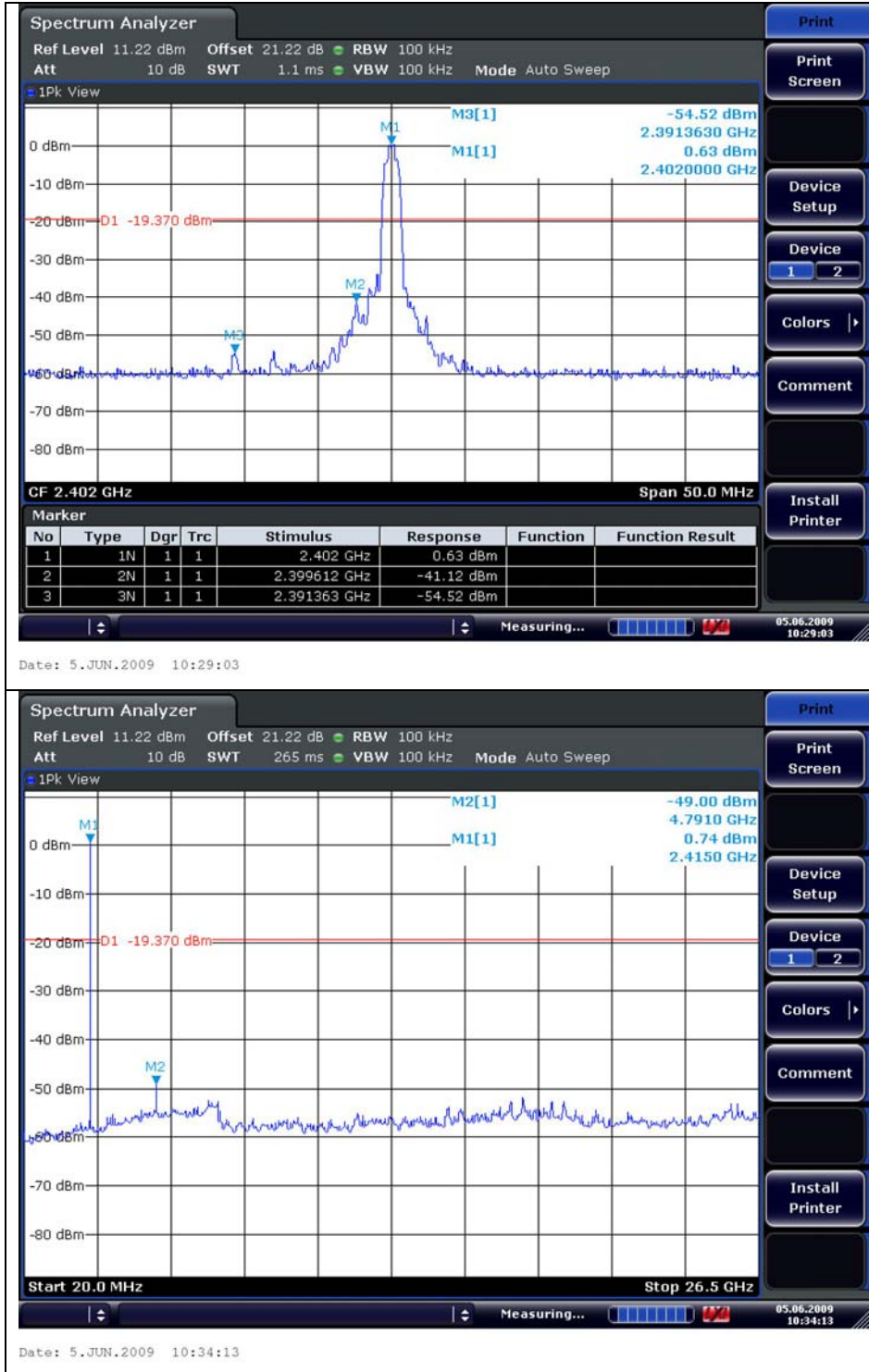

The results shown in this test report refer only to the sample(s) tested unless otherwise stated. This test report cannot be reproduced, except in full, without prior written permission of the Company.

Middle Channel

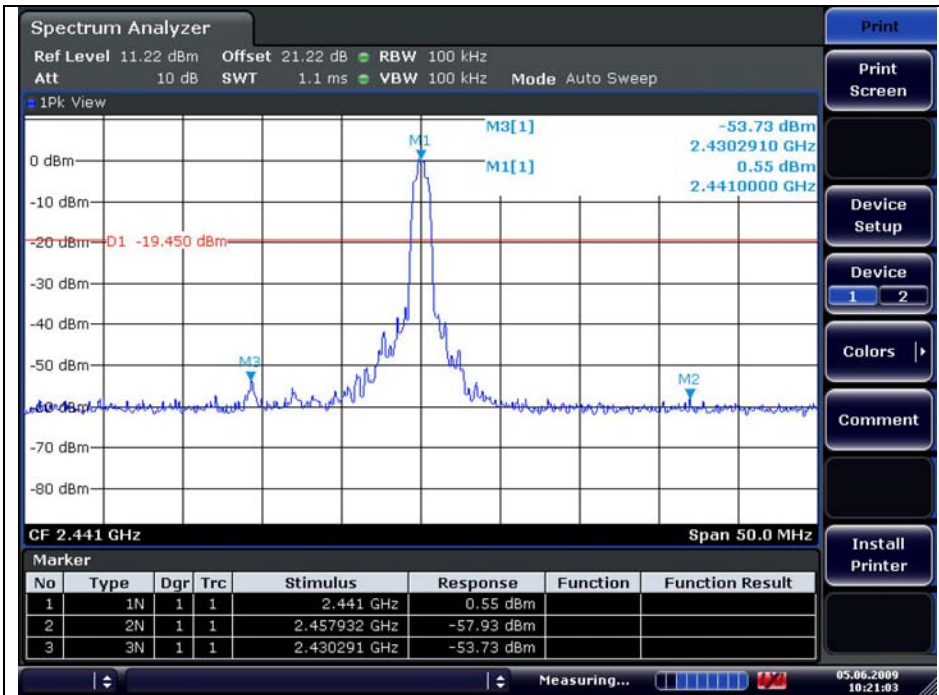

Date: 5.JUN.2009 10:21:03

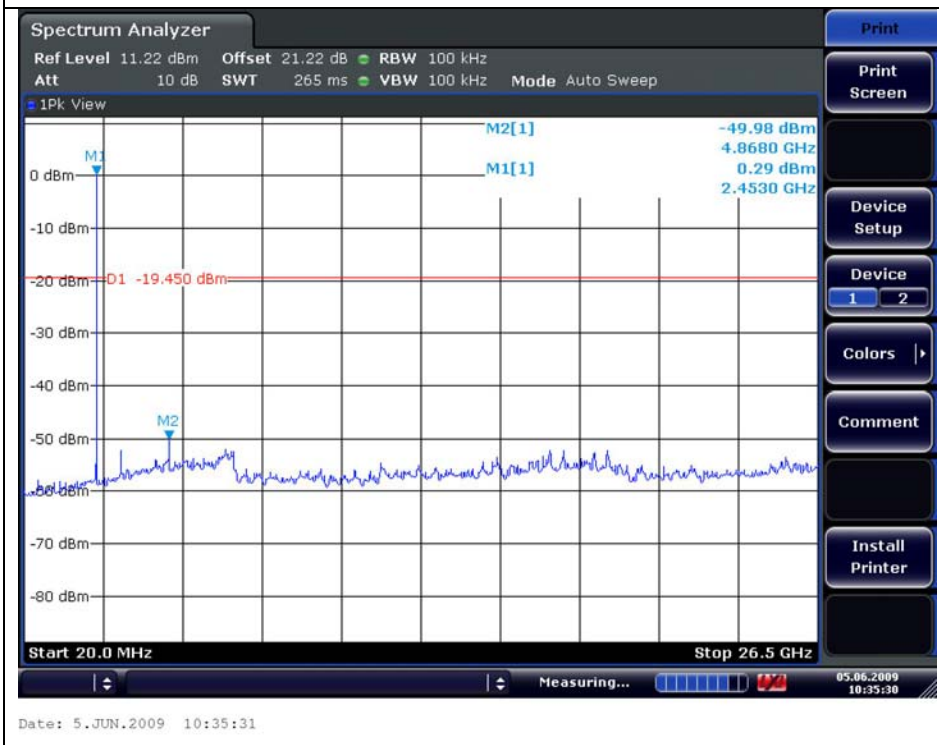

Date: 5.JUN.2009 10:35:31

The results shown in this test report refer only to the sample(s) tested unless otherwise stated. This test report cannot be reproduced, except in full, without prior written permission of the Company.

High Channel

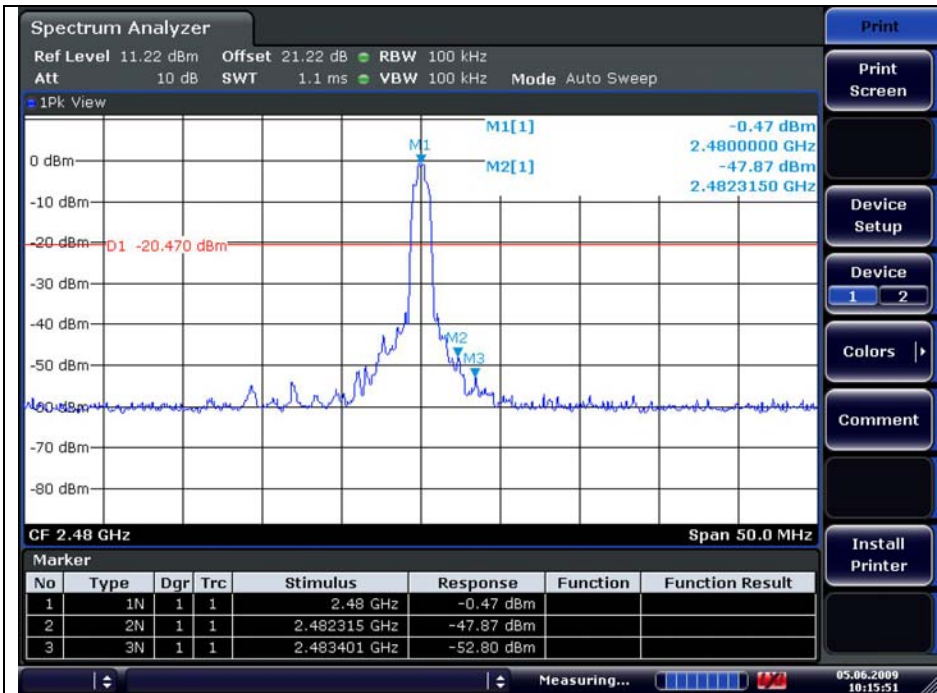

Date: 5.JUN.2009 10:15:52

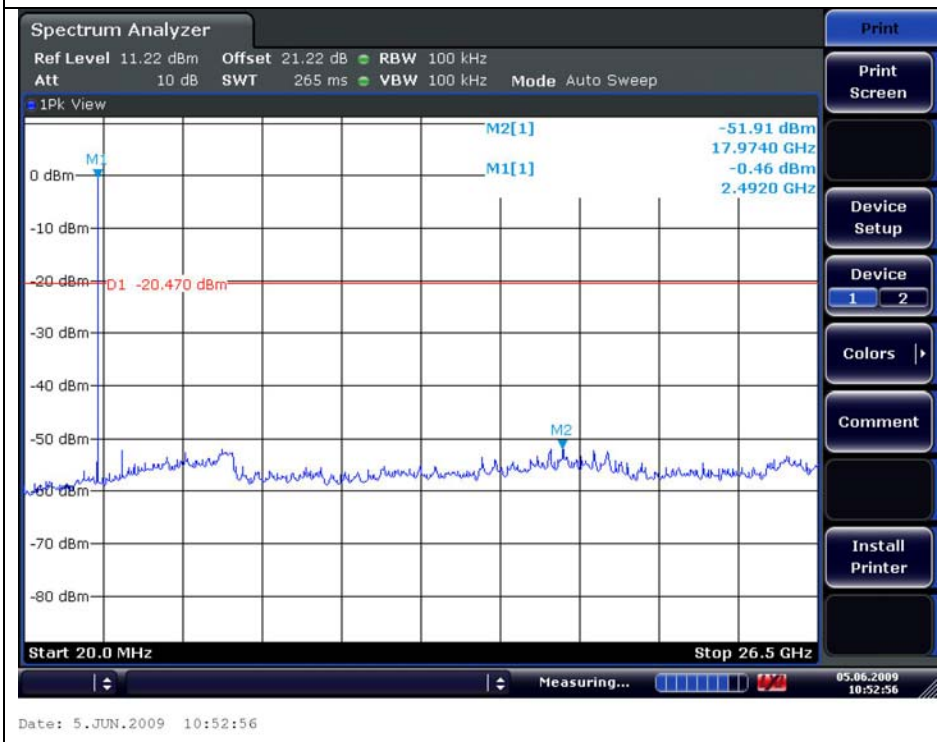

Date: 5.JUN.2009 10:52:56

The results shown in this test report refer only to the sample(s) tested unless otherwise stated. This test report cannot be reproduced, except in full, without prior written permission of the Company.

5. Receiver Radiated spurious emissions

5.1. Test setup - Same as clause 4.1.

5.1.1. Receiver Radiated Spurious Emissions - Same as clause 4.1.1.

5.2. Limit

According to §15.109(a), Except for Class A digital devices, the field strength of radiated emission from unintentional radiator at a distance of 3 m shall not exceed the following values:

Frequency (MHz)	Distance (Meters)	Radiated (dBµV/m)	Radiated (µV/m)
30 - 88	3	40.0	100
88 – 216	3	43.5	150
216 – 960	3	46.0	200
Above 960	3	54.0	500

5.3. Test Procedures - Same as clause 4.3.

Radiated emissions from the EUT were measured according to the dictates of ANSI C63.4:2003

5.3.1. Test Procedures for Radiated Spurious Emissions- Same as clause 4.3.1.

The results shown in this test report refer only to the sample(s) tested unless otherwise stated. This test report cannot be reproduced, except in full, without prior written permission of the Company.

5.4. Test Results

Ambient temperature : 24 °C
 Relative humidity : 47 % R.H.

3.4.1. Spurious Radiated Emission (Worst case configuration_GFSK mode)

The frequency spectrum from 30 MHz to 1000 MHz was investigated. Emission levels are not reported much lower than the limits by over 30 dB. All reading values are quasi-peak values.

Radiated Emissions			Ant	Correction Factors		Total	FCC Limit	
Frequency (MHz)	Reading (dBUV)	Detect Mode	Pol.	AF (dB/m)	CL (dB)	Actual (dBUV/m)	Limit (dBUV/m)	Margin (dB)
260.375	10.71	Q.P.	H	9.81	1.81	22.33	46.00	23.67
316.150	9.35	Q.P.	H	11.36	2.00	22.72	46.00	23.28
784.175	4.07	Q.P.	H	19.53	3.17	26.77	46.00	19.23
820.550	6.38	Q.P.	H	19.90	3.24	29.53	46.00	16.47
847.225	5.93	Q.P.	V	20.30	3.28	29.51	46.00	16.49
866.625	4.54	Q.P.	H	20.56	3.32	28.42	46.00	17.58
Above 900.000	Not detected	-	-	-	-	-	-	-

Remark:

1. All spurious emission at channels are almost the same below 1 GHz, so that the channel was chosen at representative in final test.
2. “*” means the restricted band.
3. Actual = Reading + AF + CL
4. The emission levels above 900 MHz are very lower than the limit by over 30 dB.

The results shown in this test report refer only to the sample(s) tested unless otherwise stated. This test report cannot be reproduced, except in full, without prior written permission of the Company.

6. 20 dB Bandwidth Measurement and 99% BW

6.1. Test Setup

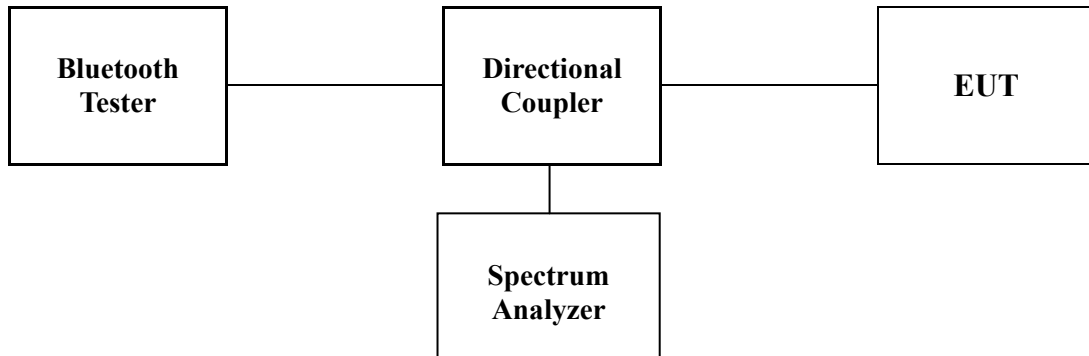

6.2. Limit

Limit: Not Applicable

6.3. Test Procedure

1. The 20dB band width was measured with a spectrum analyzer connected to RF antenna connector(conducted measurement) while EUT was operating in transmit mode at the appropriate center frequency. The analyzer center frequency was set to the EUT carrier frequency, using the analyzer. Display Line and Marker Delta functions, the 20dB band width of the emission was determined.
2. The bandwidth of the fundamental frequency was measured with the spectrum analyzer using RBW=10 kHz, VBW=10 kHz, Span=2 MHz.

The results shown in this test report refer only to the sample(s) tested unless otherwise stated. This test report cannot be reproduced, except in full, without prior written permission of the Company.

6.4. Test Results

Ambient temperature : 24 °C
 Relative humidity : 47 % R.H.

Operation Mode	Channel	Channel Frequency (MHz)	20 dB Bandwidth (MHz)	99% Bandwidth (MHz)
GFSK	Low	2402	0.91	0.85
	Middle	2441	0.91	0.85
	High	2480	0.91	0.85
8DPSK	Low	2402	1.20	1.15
	Middle	2441	1.20	1.15
	High	2480	1.20	1.14

The results shown in this test report refer only to the sample(s) tested unless otherwise stated. This test report cannot be reproduced, except in full, without prior written permission of the Company.

20 dB Bandwidth
Operating Mode: GFSK
 Low Channel



Middle Channel



The results shown in this test report refer only to the sample(s) tested unless otherwise stated. This test report cannot be reproduced, except in full, without prior written permission of the Company.

High Channel

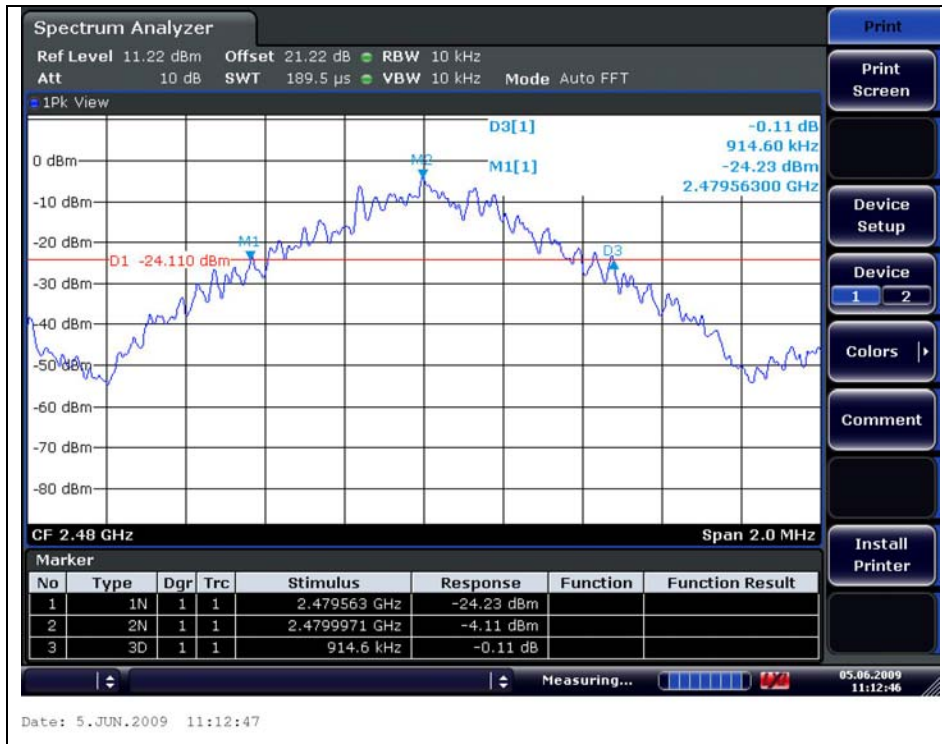

Operating Mode: 8DPSK

Low Channel



The results shown in this test report refer only to the sample(s) tested unless otherwise stated. This test report cannot be reproduced, except in full, without prior written permission of the Company.

Middle Channel

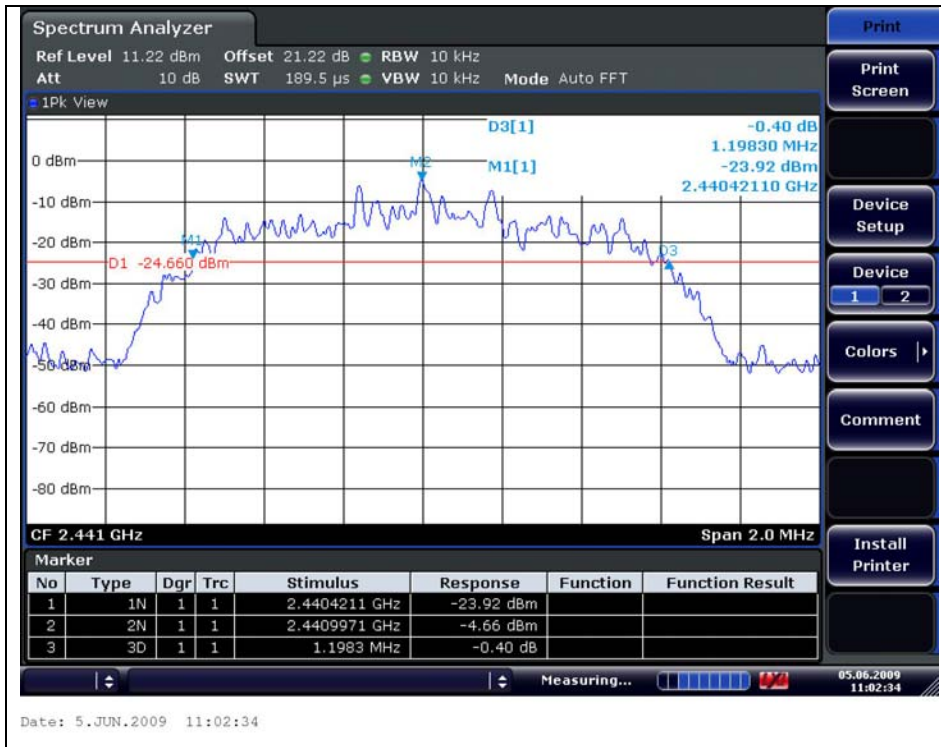

High Channel



The results shown in this test report refer only to the sample(s) tested unless otherwise stated. This test report cannot be reproduced, except in full, without prior written permission of the Company.

99% Bandwidth

Operating Mode: GFSK

Low Channel



Middle Channel

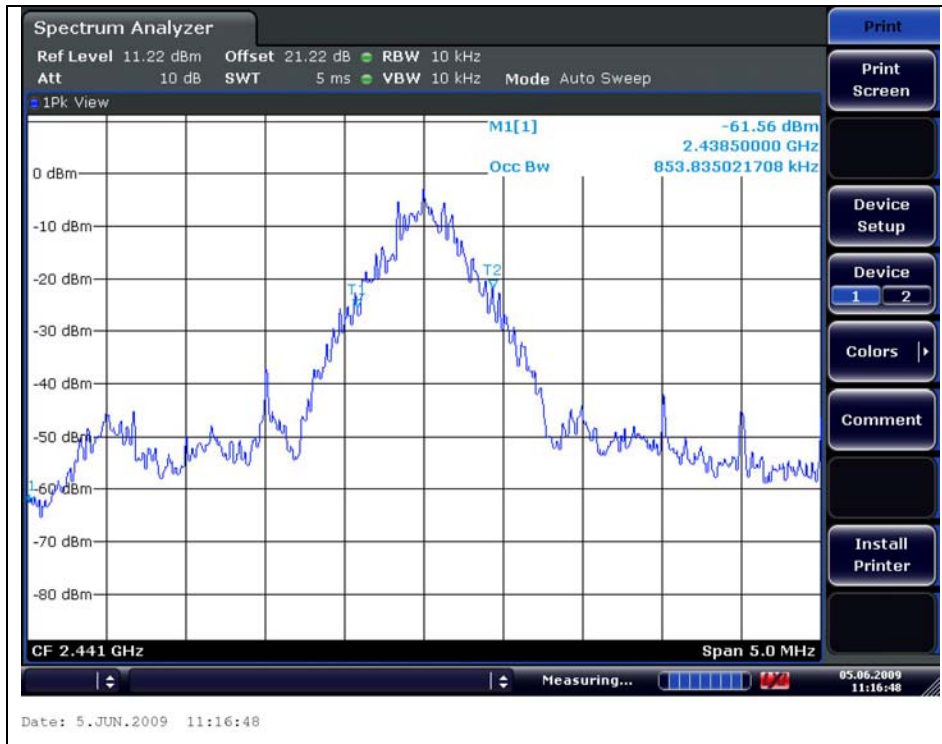

The results shown in this test report refer only to the sample(s) tested unless otherwise stated. This test report cannot be reproduced, except in full, without prior written permission of the Company.

High Channel

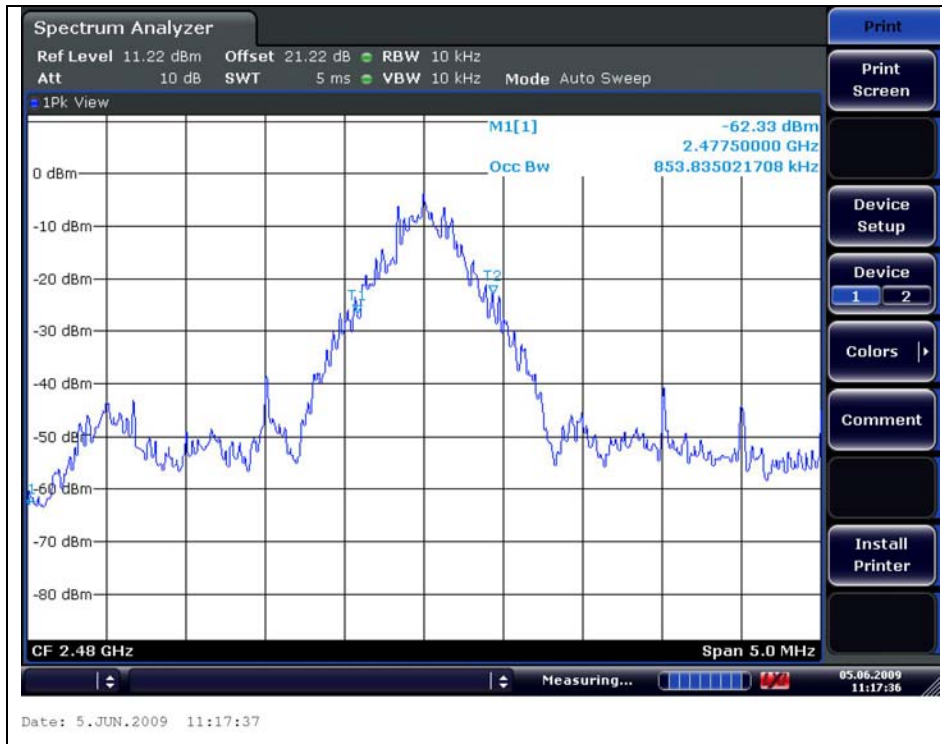

Operating Mode: 8DPSK

Low Channel

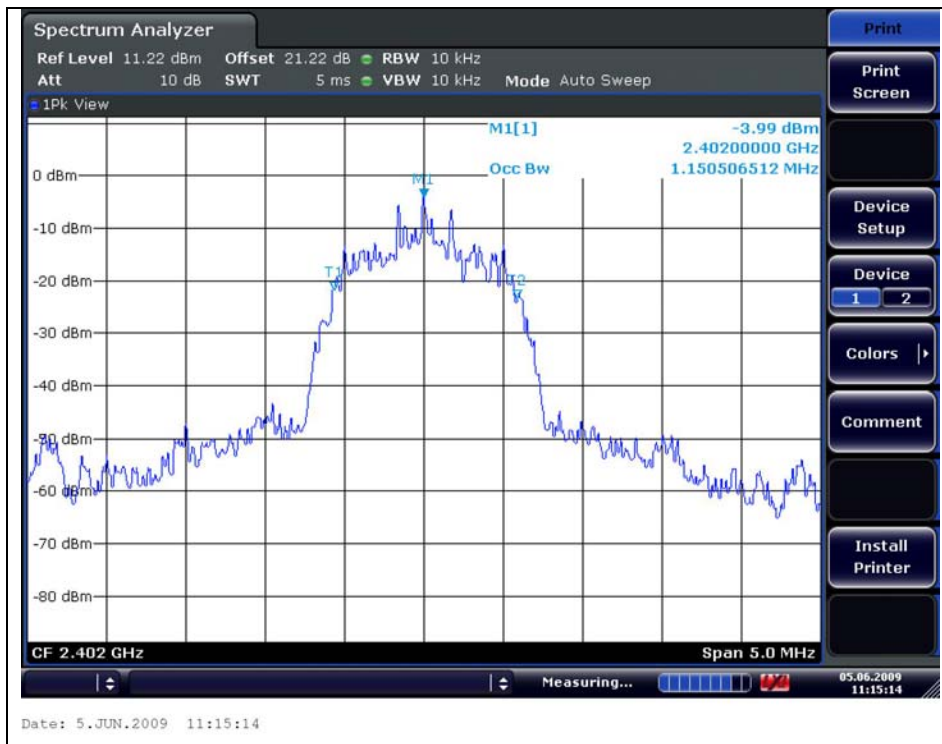

The results shown in this test report refer only to the sample(s) tested unless otherwise stated. This test report cannot be reproduced, except in full, without prior written permission of the Company.

Middle Channel



High Channel

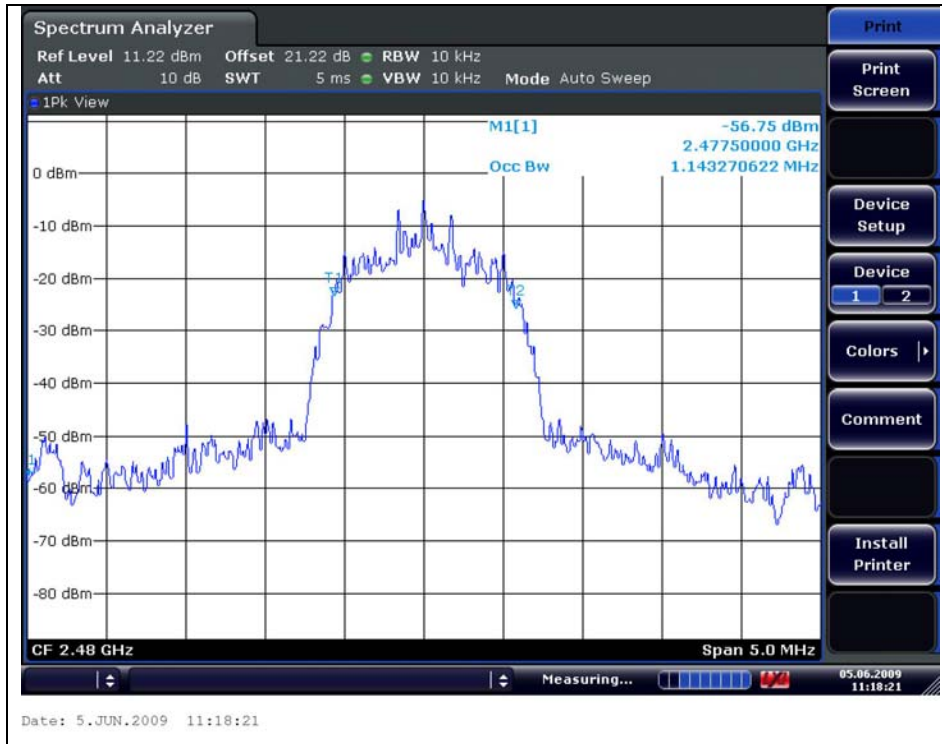

The results shown in this test report refer only to the sample(s) tested unless otherwise stated. This test report cannot be reproduced, except in full, without prior written permission of the Company.

7. Maximum Peak Output Power Measurement

7.1. Test Setup

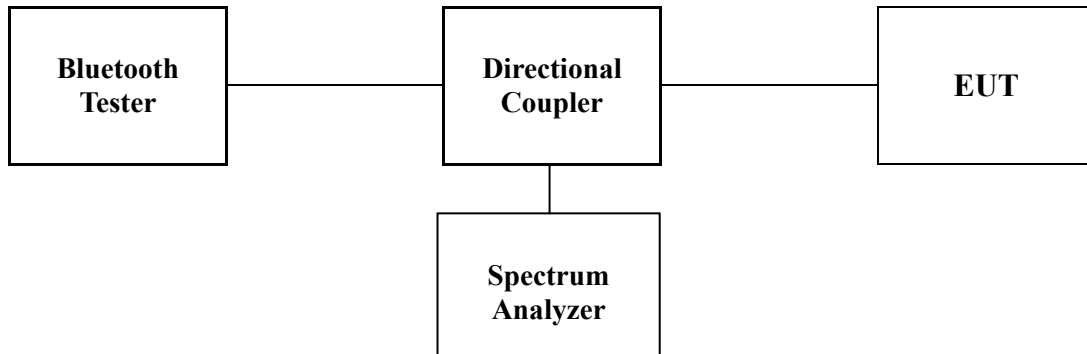

7.2. Limit

The maximum peak output power of the intentional radiator shall not exceed the following :

1. §15.247(a)(1), Frequency hopping systems shall have hopping channel carrier frequencies separated by a minimum of 25 kHz or the 20 dB bandwidth of the hopping channel, whichever is greater, provided the systems operate with an output power no greater than 125 mW.
2. §15.247(b)(1), For frequency hopping systems operating in the 2400-2483.5 MHz employing at least 75 non-overlapping hopping channels, and all frequency hopping systems in the 5725-5805 MHz band: 1 Watt.

7.3. Test Procedure

1. The RF power output was measured with a Spectrum analyzer connected to the RF Antenna connector (conducted measurement) while EUT was operating in transmit mode at the appropriate center frequency, A spectrum analyzer was used to record the shape of the transmit signal.
2. The bandwidth of the fundamental frequency was measured with the spectrum analyzer using ;
 Span = approximately 5 times the 20 dB bandwidth, centered on a hopping channel
 RBW \geq 20dB BW
 VBW \geq RBW
 Sweep = auto
 Detector function = peak
 Trace = max hold

The results shown in this test report refer only to the sample(s) tested unless otherwise stated. This test report cannot be reproduced, except in full, without prior written permission of the Company.

7.4. Test Results

Ambient temperature : 24 °C
 Relative humidity : 47 % R.H.

Operation Mode	Channel	Channel Frequency (MHz)	Peak Power Output (dBm)	Peak Power Limit (dBm)
GFSK	Low	2402	2.42	30.00
	Middle	2441	2.24	30.00
	High	2480	1.38	30.00
8DPSK	Low	2402	2.11	20.97
	Middle	2441	1.76	20.97
	High	2480	0.80	20.97

The results shown in this test report refer only to the sample(s) tested unless otherwise stated. This test report cannot be reproduced, except in full, without prior written permission of the Company.

Operating Mode: GFSK

Low Channel

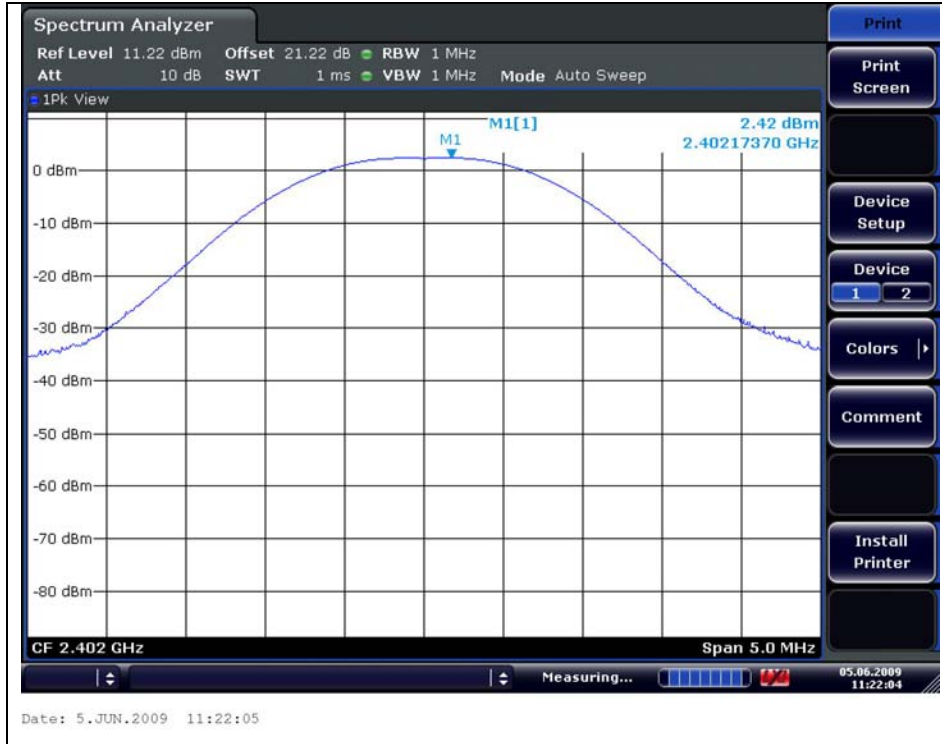

Middle Channel

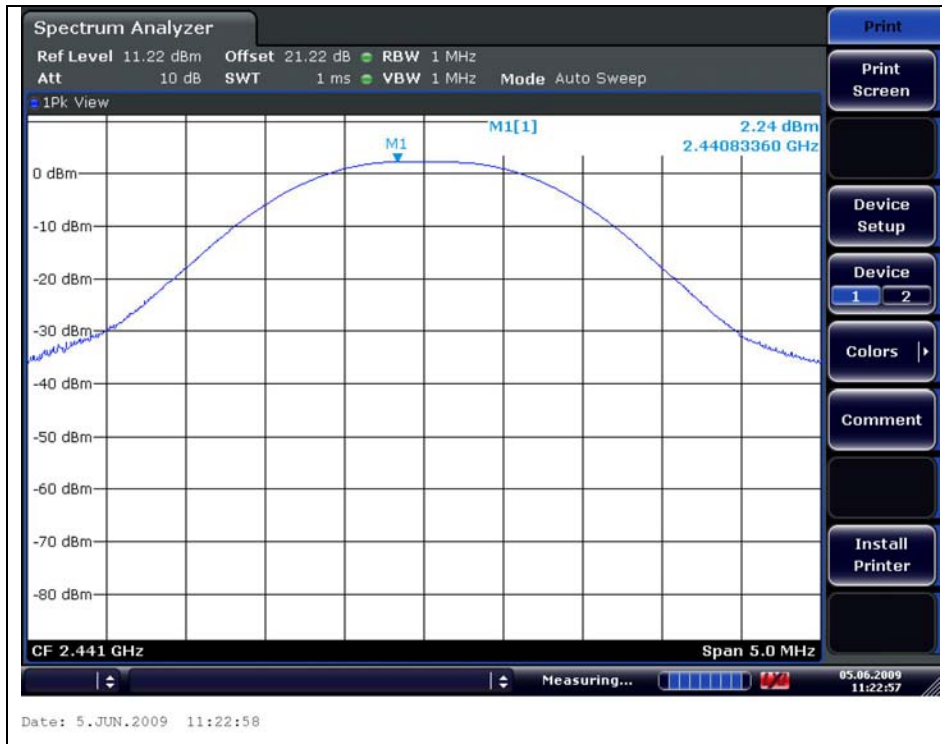

The results shown in this test report refer only to the sample(s) tested unless otherwise stated. This test report cannot be reproduced, except in full, without prior written permission of the Company.

High Channel

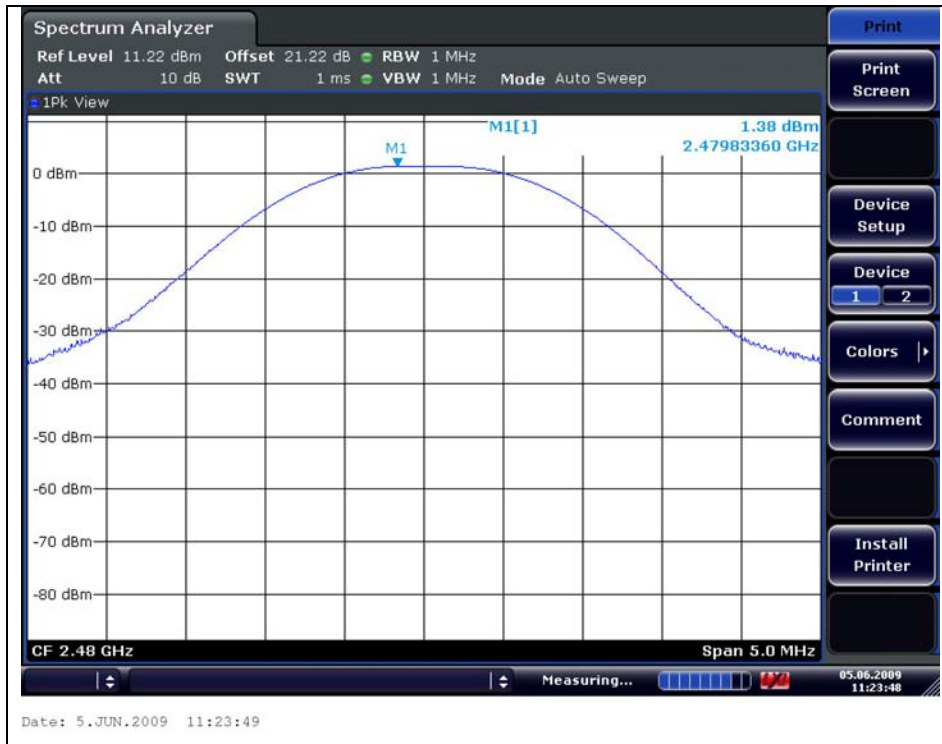

Operating Mode: 8DPSK

Low Channel

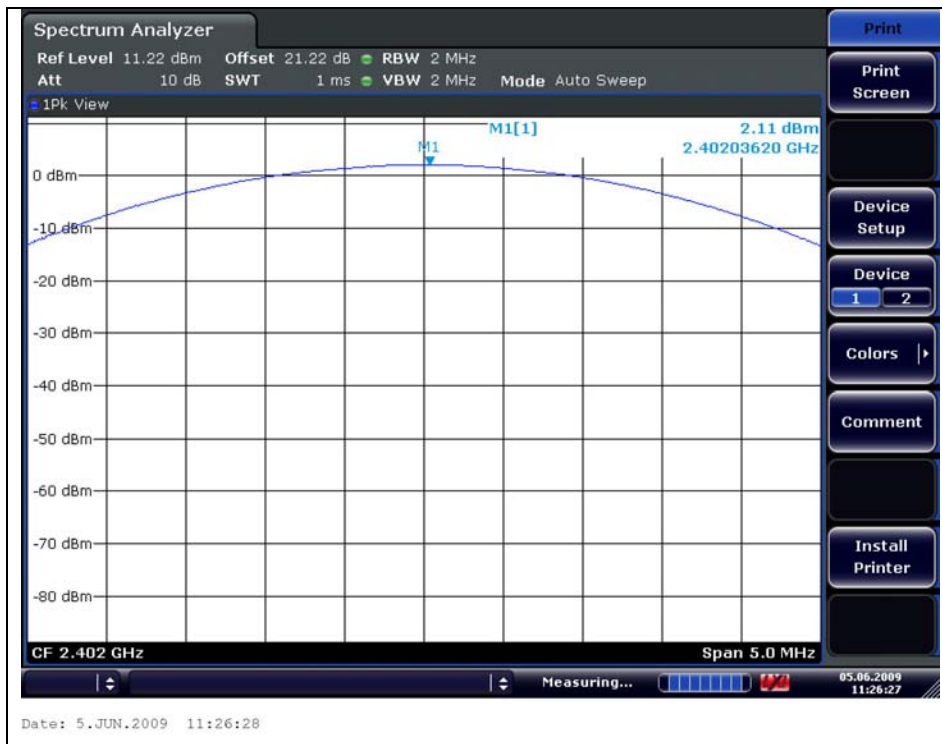

The results shown in this test report refer only to the sample(s) tested unless otherwise stated. This test report cannot be reproduced, except in full, without prior written permission of the Company.

Middle Channel

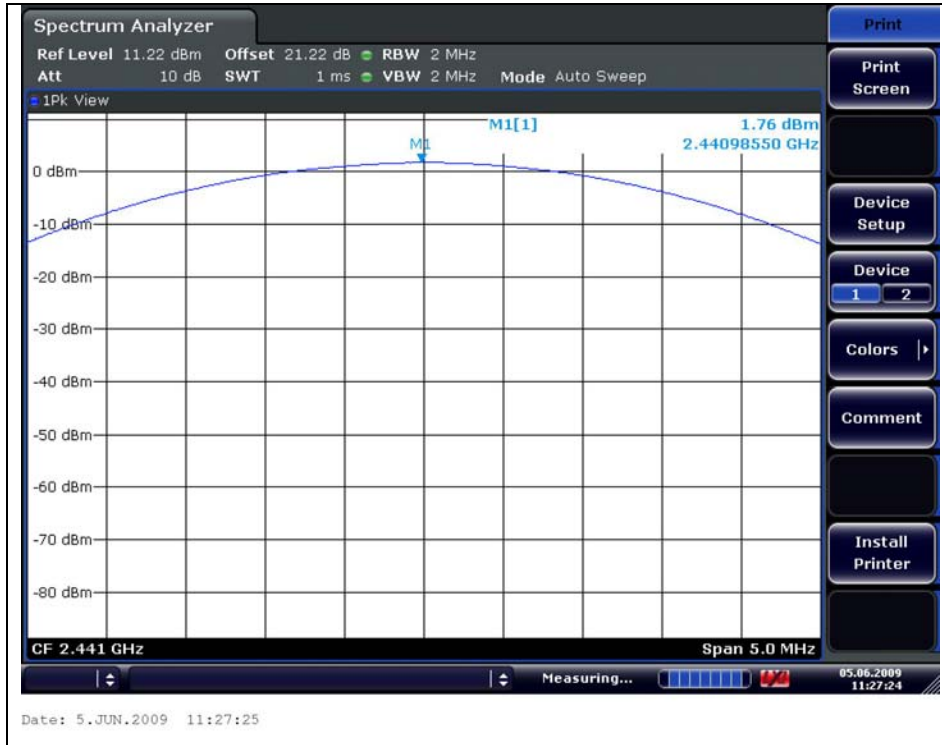

High Channel

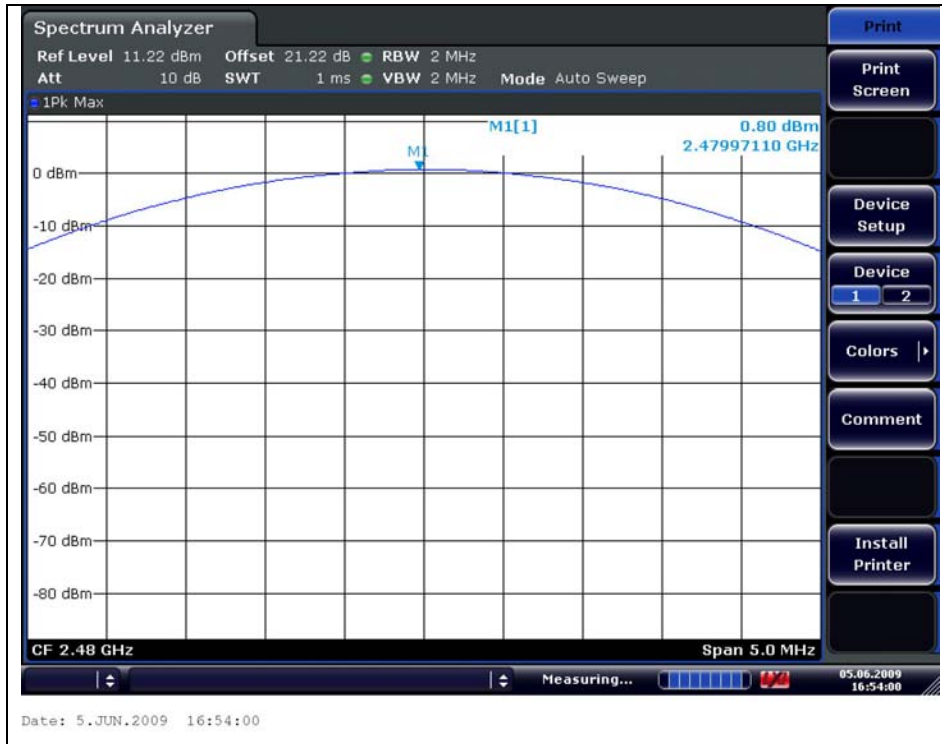

The results shown in this test report refer only to the sample(s) tested unless otherwise stated. This test report cannot be reproduced, except in full, without prior written permission of the Company.

8. Hopping Channel Separation

8.1. Test Setup

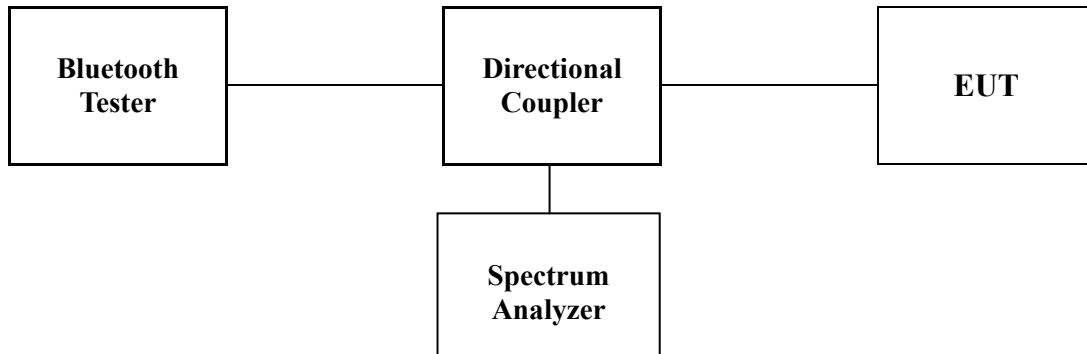

8.2. Limit

§15.247(a)(1) Frequency hopping system operating in 2400-2483.5MHz. Band may have hopping channel carrier frequencies that are separated by 25kHz or two-third of 20dB bandwidth of the hopping channel, whichever is greater, provided the systems operate with an output power no greater than 125mW.

8.3. Test Procedure

1. Check the calibration of the measuring instrument using either an internal calibrator or a known signal from an external generator.
2. Position the EUT as shown in test setup without connection to measurement instrument. Turn on the EUT and connect it to measurement instrument. Then set it to any one convenient frequency within its operating range.
3. By using the MaxHold function record the separation of adjacent channels.
4. Measure the frequency difference of these two adjacent channels by spectrum analyzer MARK function. And then plot the result on spectrum analyzer screen.
5. Repeat above procedures until all frequencies measured were complete.
6. Set center frequency of spectrum analyzer = middle of hopping channel.
7. Set the spectrum analyzer as RBW=100 kHz, VBW=100 kHz, Span=5 MHz and Sweep = auto.

The results shown in this test report refer only to the sample(s) tested unless otherwise stated. This test report cannot be reproduced, except in full, without prior written permission of the Company.

8.4. Test Results

Ambient temperature : 24 °C
 Relative humidity : 47 % R.H.

Operation Mode	Channel (Middle)	Adjacent Hopping Channel Separation (kHz)	Two-third of 20 dB Bandwidth (kHz)	Minimum Bandwidth (kHz)
GFSK	2441 MHz	999	607	25
8DPSK	2441 MHz	999	800	25

Note ;
 20 dB bandwidth measurement, the measured channel separation should be greater than two-third of 20dB bandwidth or Minimum bandwidth.

The results shown in this test report refer only to the sample(s) tested unless otherwise stated. This test report cannot be reproduced, except in full, without prior written permission of the Company.

Operating Mode: GFSK

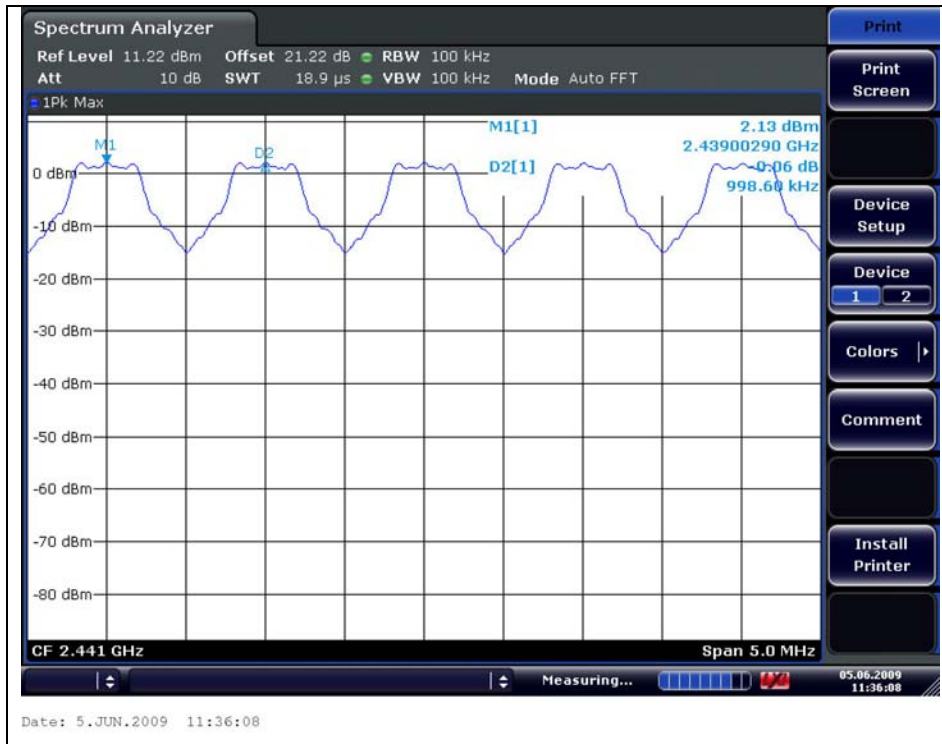

Operating Mode: 8DPSK



The results shown in this test report refer only to the sample(s) tested unless otherwise stated. This test report cannot be reproduced, except in full, without prior written permission of the Company.

9. Number of Hopping Frequency

9.1. Test Setup

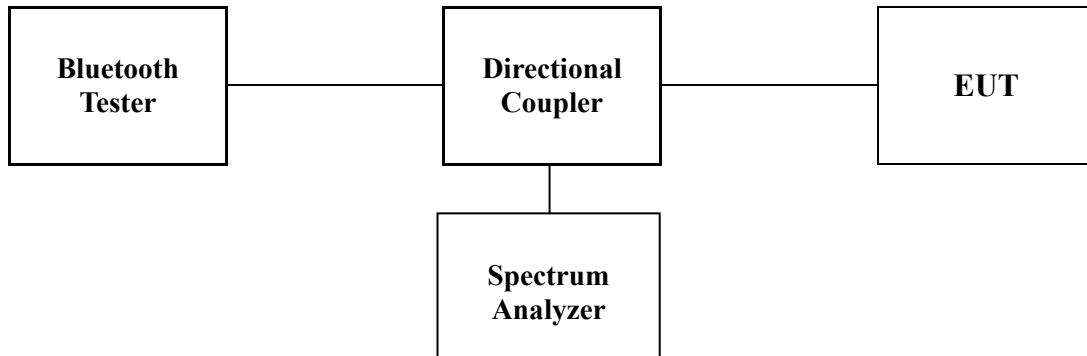

9.2. Limit

§15.247(a)(1)(iii) For frequency hopping system operating in the 2400-2483.5MHz bands shall use at least 15 hopping frequencies.

9.3. Test Procedure

1. Place the EUT on the table and set it in transmitting mode.
2. Remove the antenna from the EUT and then connect a low loss RF cable from the antenna the port to the Spectrum analyzer
3. Set spectrun analyzer Start=2400 MHz, Stop=2441.5 MHz, Sweep=auto and Start=2441.5 MHz, Stop=2483.5 MHz, Sweep=auto.
4. Set the spectrum analyzer as RBW, VBW=300 kHz.
5. Max hold, view and count how many channel in the band.

The results shown in this test report refer only to the sample(s) tested unless otherwise stated. This test report cannot be reproduced, except in full, without prior written permission of the Company.

9.4. Test Results

Ambient temperature : 24 °C
 Relative humidity : 47 % R.H.

Operation Mode	Number of Hopping Frequency	Limit
GFSK	79	≥ 15
8DPSK	79	≥ 15

The results shown in this test report refer only to the sample(s) tested unless otherwise stated. This test report cannot be reproduced, except in full, without prior written permission of the Company.

Operating Mode: GFSK

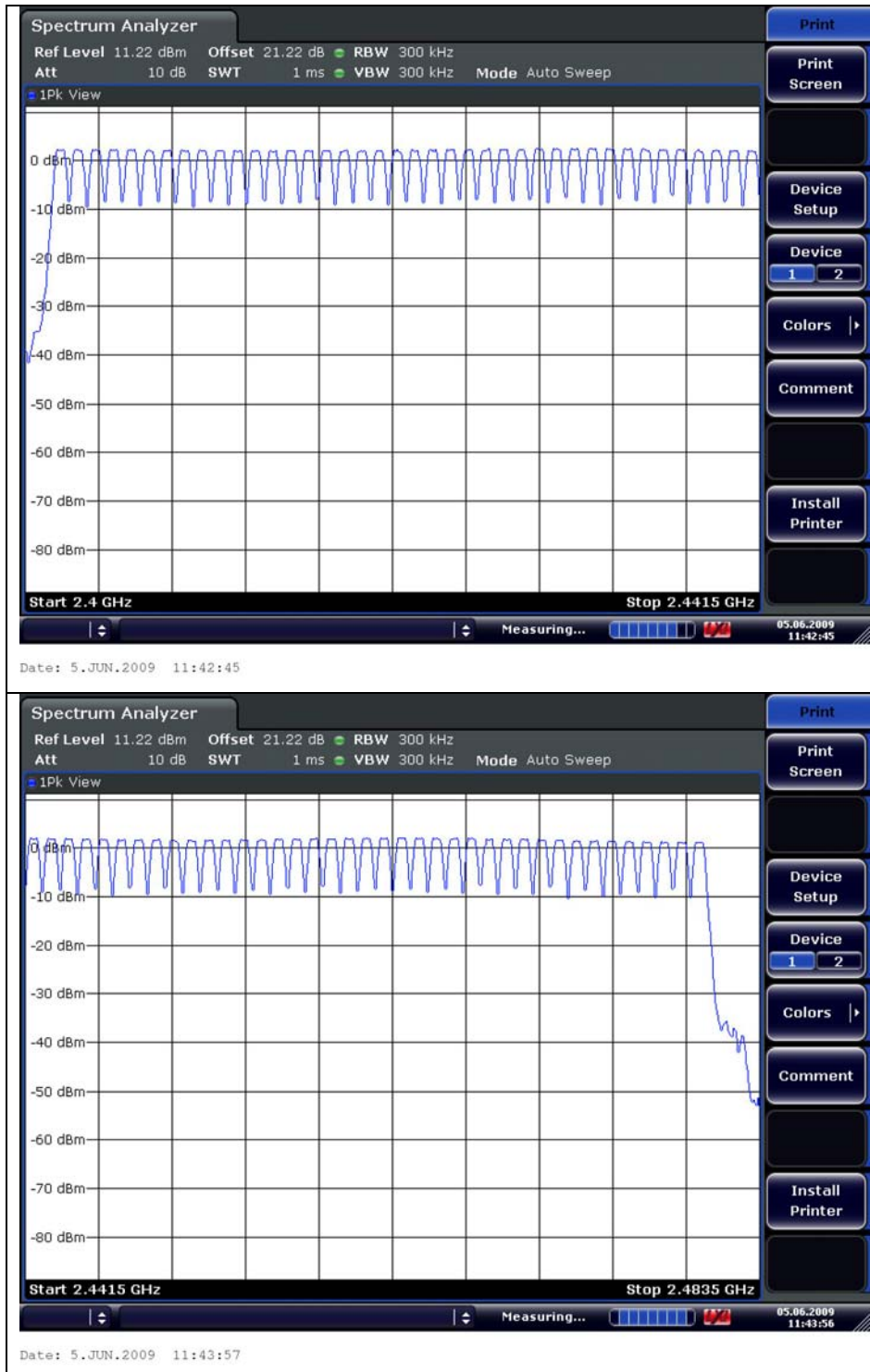

The results shown in this test report refer only to the sample(s) tested unless otherwise stated. This test report cannot be reproduced, except in full, without prior written permission of the Company.

Operating Mode: 8DPSK

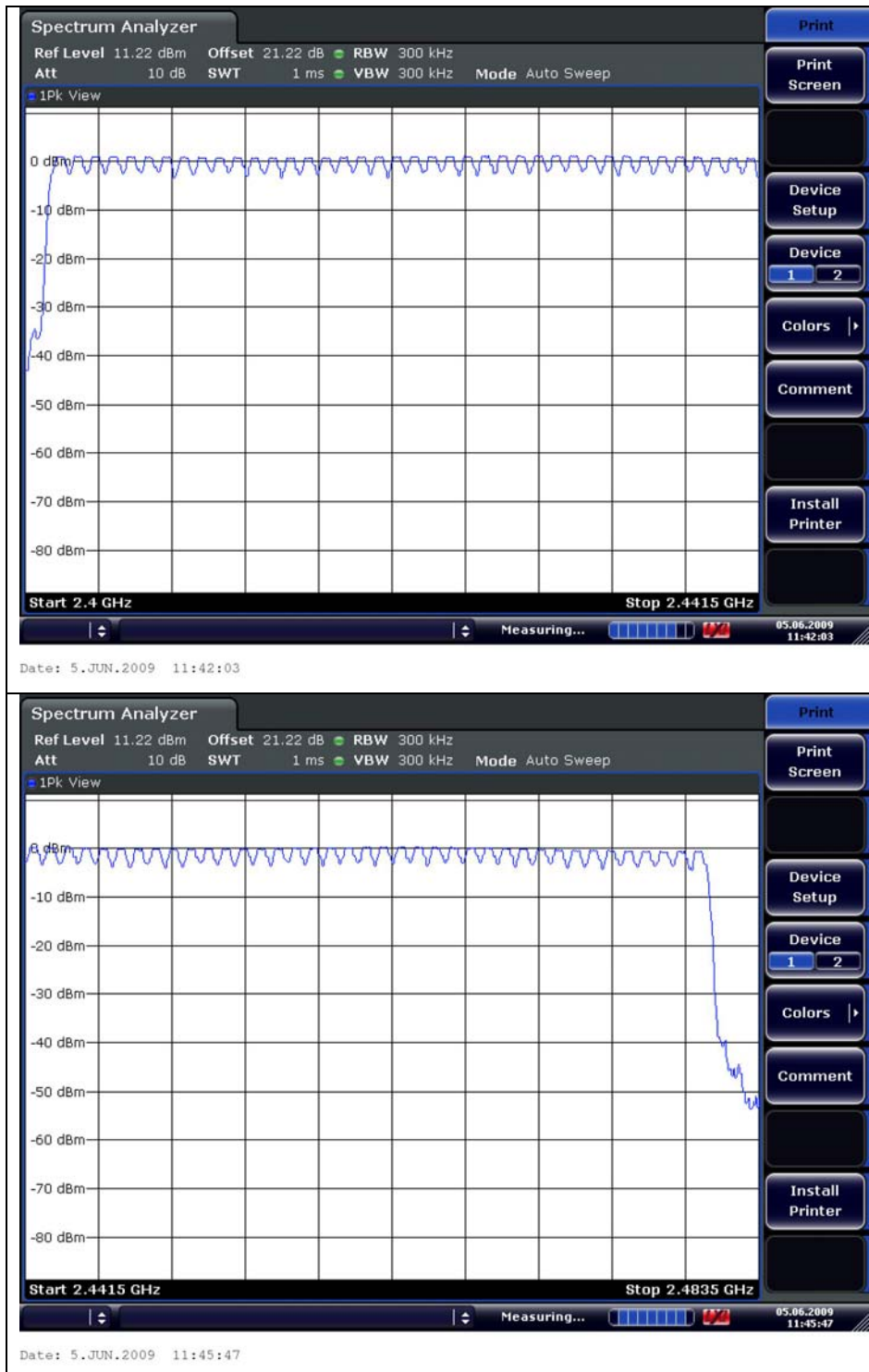

The results shown in this test report refer only to the sample(s) tested unless otherwise stated. This test report cannot be reproduced, except in full, without prior written permission of the Company.

10. Time Of Occupancy (Dwell Time)

10.1. Test Set up

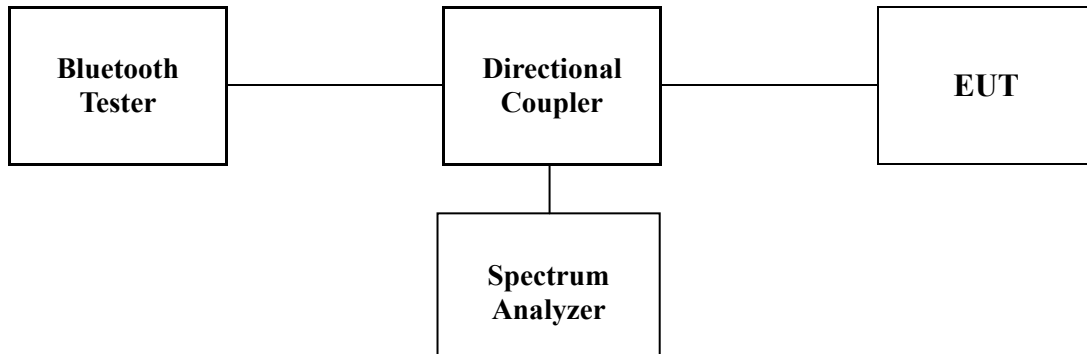

10.2. Limit

§15.247(a)(1)(iii) For frequency hopping system operating in the 2400-2483.5MHz band, the average time of occupancy on any frequency shall not be greater than 0.4 second within a 31.6 second period.

A period time=0.4(s)*79=31.6(s)

10.3. Test Procedure

1. Check the calibration of the measuring instrument using either an internal calibrator or a known signal from an external generator.
2. Position the EUT as shown in test setup without connection to measurement instrument. Turn on the EUT and connect its antenna terminal to measurement instrument via a low loss cable.
3. Adjust the center frequency of spectrum analyzer on any frequency be measured and set spectrum analyzer to zero span mode. And then, set RBW and VBW of spectrum analyzer to proper value.
4. Measure the time duration of one transmission on the measured frequency. And then plot the result with time difference of this time duration.
5. Repeat above procedures until all frequencies measured were complete.
6. The Bluetooth has 3 type of payload, DH1, DH3, DH5 and 3-DH1, 3-DH3, 3-DH5. The hopping rate is 1600 per second.

The results shown in this test report refer only to the sample(s) tested unless otherwise stated. This test report cannot be reproduced, except in full, without prior written permission of the Company.

10.4. Test Results

Ambient temperature : 24 °C
 Relative humidity : 47 % R.H.

Time of occupancy on the TX channel in 31.6sec
 = time domain slot length × (hop rate ÷ number of hop per channel) × 31.6

10.4.1. Packet Type: DH1, 3-DH1

Operation Mode	Frequency	Dwell Time (ms)	Time of occupancy on the Tx Channel in 31.6 sec (ms)	Limit for time of occupancy on the Tx Channel in 31.6 sec (ms)
GFSK	2441 MHz	0.39	124.80	400
8DPSK	2441 MHz	0.41	131.20	400

2441 MHz : 0.39 (ms) × [(1600÷2) ÷79] ×31.6(s) = 124.80 (ms)
 0.41 (ms) × [(1600÷2) ÷79] ×31.6(s) = 131.20 (ms)

The results shown in this test report refer only to the sample(s) tested unless otherwise stated. This test report cannot be reproduced, except in full, without prior written permission of the Company.

Operating Mode: GFSK

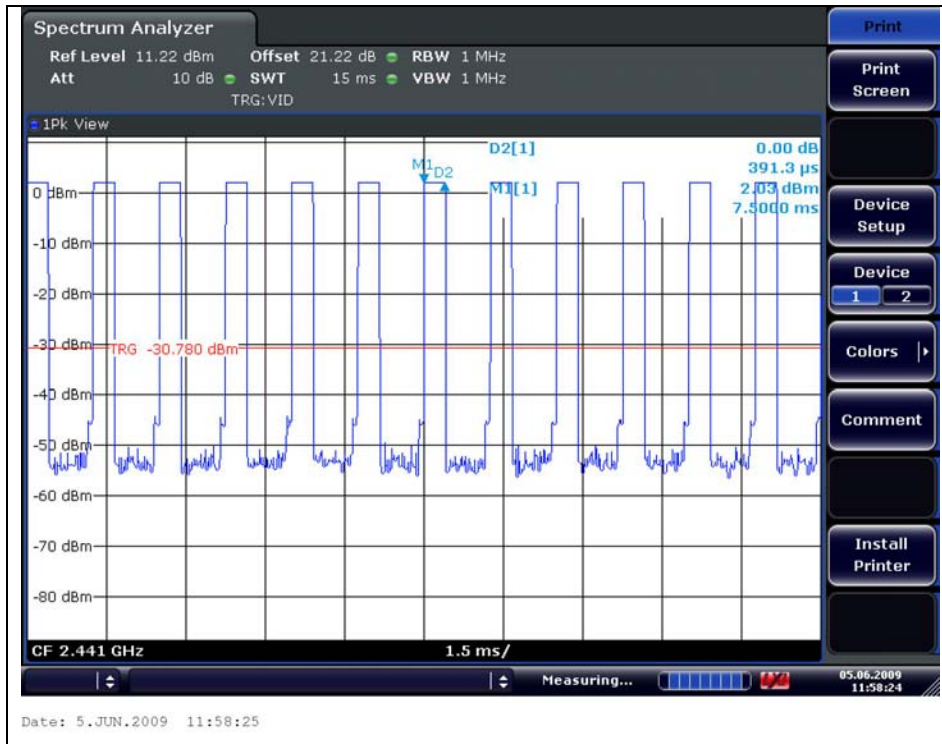

Operating Mode: 8DPSK

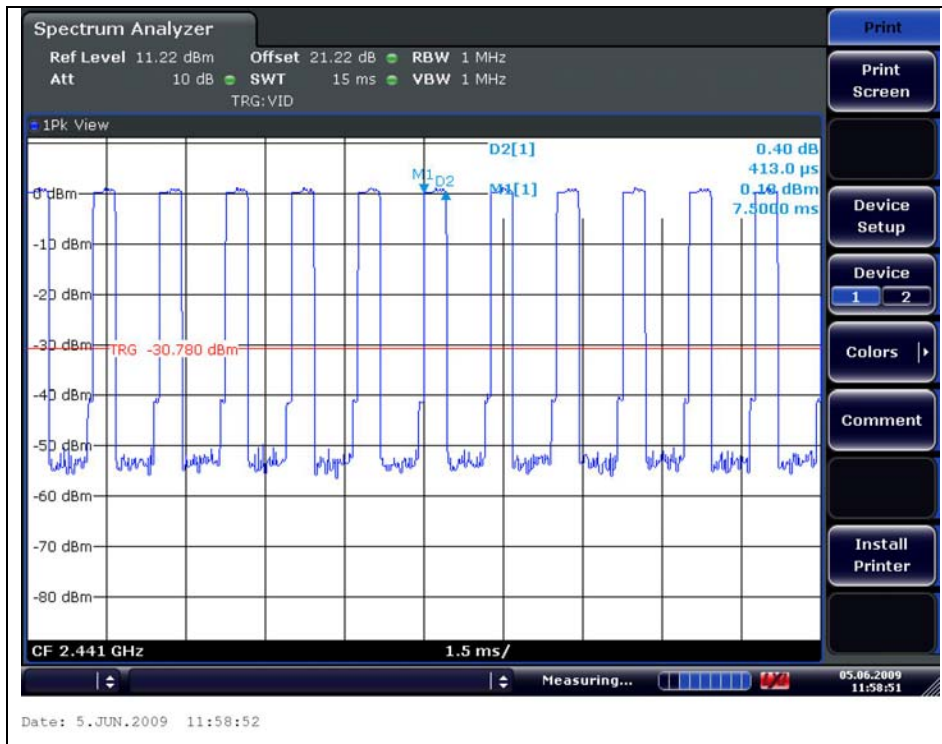

The results shown in this test report refer only to the sample(s) tested unless otherwise stated. This test report cannot be reproduced, except in full, without prior written permission of the Company.

10.4.2. Packet Type: DH3, 3-DH3

Operation Mode	Frequency	Dwell Time (ms)	Time of occupancy on the Tx Channel in 31.6 sec (ms)	Limit for time of occupancy on the Tx Channel in 31.6 sec (ms)
GFSK	2441 MHz	1.65	264.00	400
8DPSK	2441 MHz	1.65	264.00	400

$$2441 \text{ MHz} : 1.65 \text{ (ms)} \times [(1600 \div 4) \div 79] \times 31.6 \text{ (s)} = 264.00 \text{ (ms)}$$

$$1.65 \text{ (ms)} \times [(1600 \div 4) \div 79] \times 31.6 \text{ (s)} = 264.00 \text{ (ms)}$$

The results shown in this test report refer only to the sample(s) tested unless otherwise stated. This test report cannot be reproduced, except in full, without prior written permission of the Company.

Operating Mode: GFSK

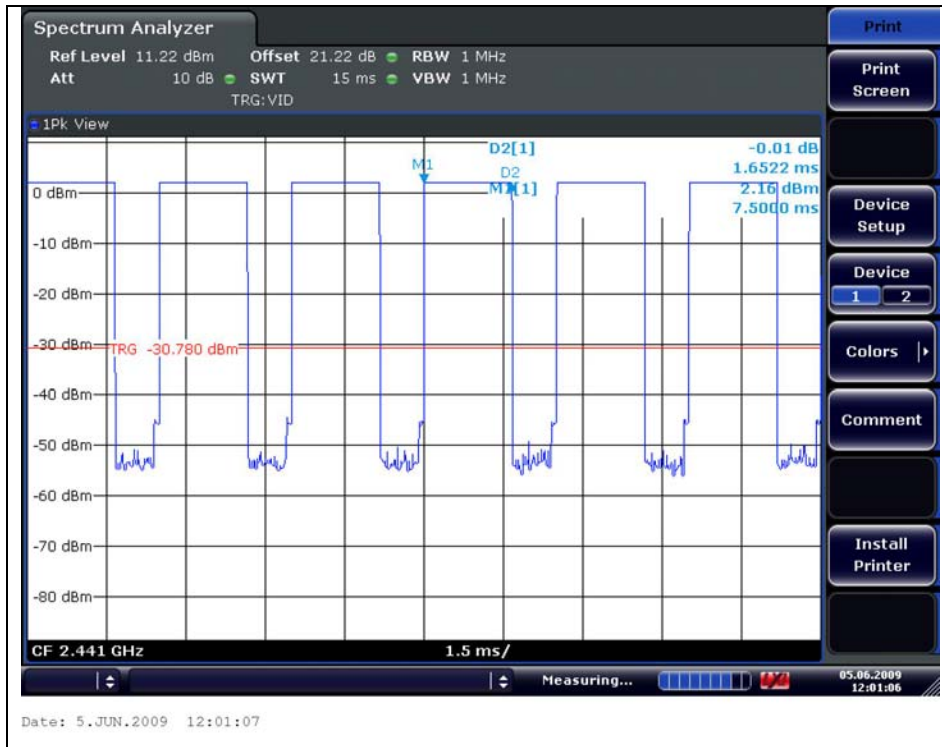

Operating Mode: 8DPSK

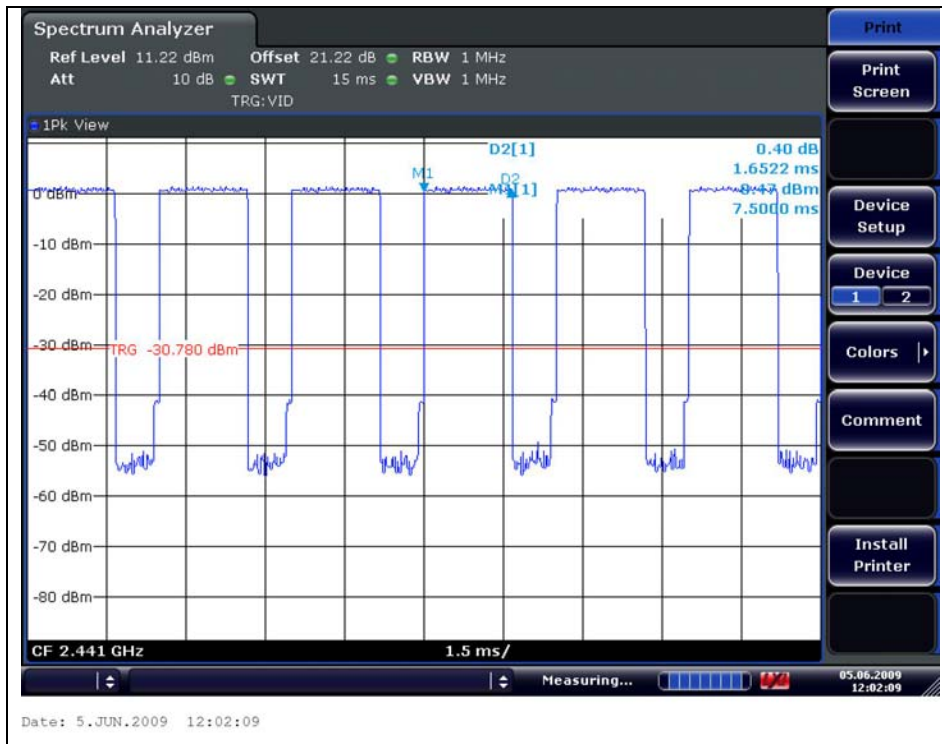

The results shown in this test report refer only to the sample(s) tested unless otherwise stated. This test report cannot be reproduced, except in full, without prior written permission of the Company.

10.4.3. Packet Type: DH5, 3-DH5

Operation Mode	Frequency	Dwell Time (ms)	Time of occupancy on the Tx Channel in 31.6 sec (ms)	Limit for time of occupancy on the Tx Channel in 31.6 sec (ms)
GFSK	2441 MHz	2.89	308.27	400
8DPSK	2441 MHz	2.91	310.40	400

2441 MHz: $2.89 \text{ (ms)} \times [(1600 \div 6) \div 79] \times 31.6 \text{ (s)} = 308.27 \text{ (ms)}$

$2.91 \text{ (ms)} \times [(1600 \div 6) \div 79] \times 31.6 \text{ (s)} = 310.40 \text{ (ms)}$

The results shown in this test report refer only to the sample(s) tested unless otherwise stated. This test report cannot be reproduced, except in full, without prior written permission of the Company.

Operating Mode: GFSK

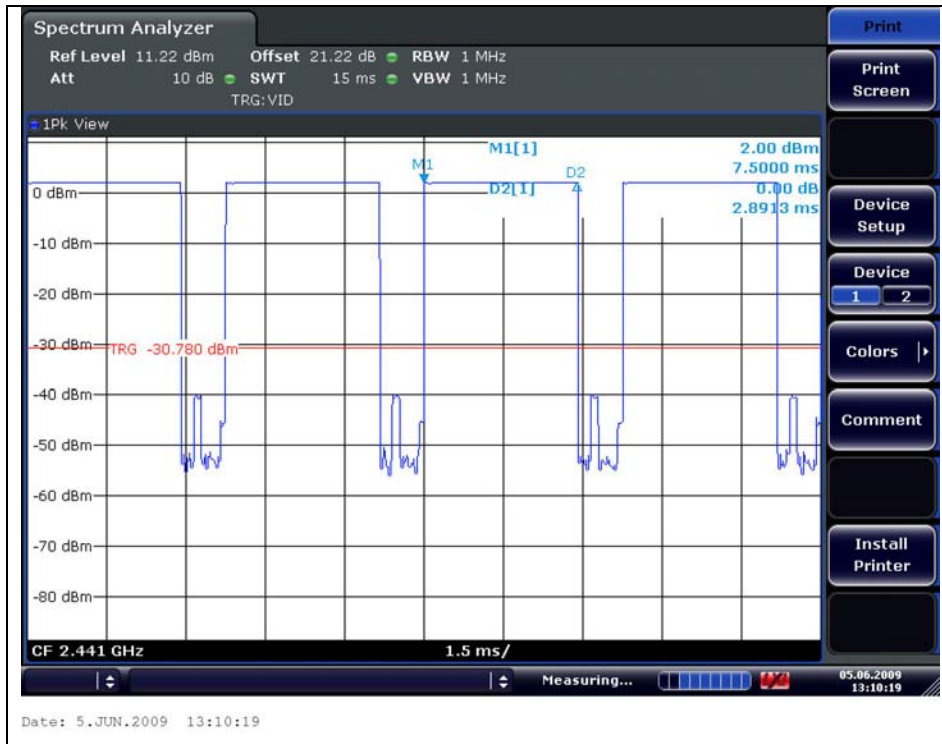

Operating Mode: 8DPSK

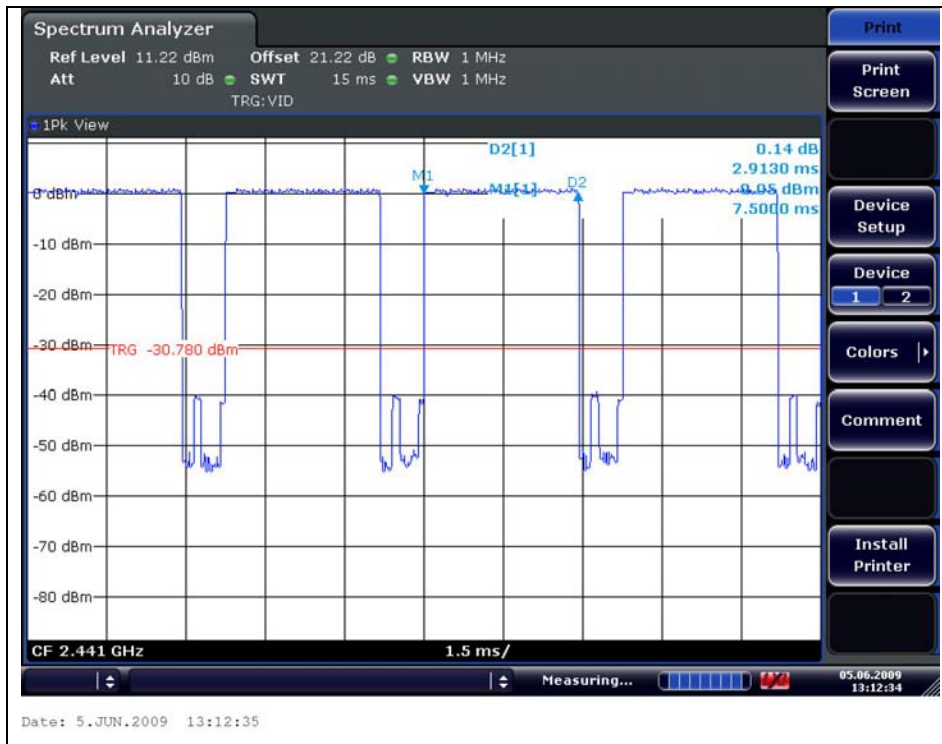

The results shown in this test report refer only to the sample(s) tested unless otherwise stated. This test report cannot be reproduced, except in full, without prior written permission of the Company.

11. Antenna Requirement

11.1. Standard Applicable

For intentional device, according to FCC 47 CFR Section §15.203, an intentional radiator shall be designed to ensure that no antenna other than that furnished by the responsible party shall be used with the device. And according to FCC 47 CFR Section §15.247 (b) if transmitting antennas of directional gain greater than 6dBi are used, the power shall be reduced by the amount in dB that the gain of the antenna exceeds 6 dBi.

11.2. Antenna Connected Construction

Antenna used in this product is Integral type (Chip Antenna) gain of 0.63 dBi.

The results shown in this test report refer only to the sample(s) tested unless otherwise stated. This test report cannot be reproduced, except in full, without prior written permission of the Company.

12. RF Exposure Evaluation

12.1 Environmental evaluation and exposure limit according to FCC CFR 47 part 1, 1.1307(b), 1.1310

According to FCC 1.1310 : The criteria listed in the following table shall be used to evaluate the environment impact of human exposure to radio frequency (RF) radiation as specified in §1.1307(b)

LIMITS FOR MAXIMUM PERMISSIBLE EXPOSURE (MPE)

Frequency Range (MHz)	Electric Field Strength(V/m)	Magnetic Field Strength (A/m)	Power Density (mW/cm ²)	Average Time
(A) Limits for Occupational /Control Exposures				
300 – 1500	--	--	F/300	6
1500 - 100000	--	--	5	6
(B) Limits for General Population/Uncontrol Exposures				
300 – 1500	--	--	F/1500	6
<u>1500 - 100000</u>	--	--	<u>1</u>	<u>30</u>

12.1.1. Friis transmission formula: $P_d = (P_{out} * G) / (4 * \pi * R^2)$

Where P_d = power density in mW/cm²

P_{out} = output power to antenna in mW

G = gain of antenna in linear scale

π = 3.1416

R = distance between observation point and center of the radiator in cm

P_d the limit of MPE, 1 mW/cm². If we know the maximum gain of the antenna and the total power input to the antenna, through the calculation, we will know the distance where the MPE limit is reached.

The results shown in this test report refer only to the sample(s) tested unless otherwise stated. This test report cannot be reproduced, except in full, without prior written permission of the Company.

12.1.2. Test Result of RF Exposure Evaluation

Test Item : RF Exposure Evaluation Data

Test Mode : Normal Operation

12.1.3. Output Power into Antenna & RF Exposure Evaluation Distance

Channel	Channel Frequency (MHz)	Output Peak Power to Antenna (dBm)	Antenna Gain (dBi)	Power Density at 20cm (mW/cm ²)	Limits (mW/cm ²)
Low	2402	2.42	0.63	0.00040	1
Middle	2441	2.24	0.63	0.00039	
High	2480	1.38	0.63	0.00032	

Note :

1. For GFSK mode.
2. The power density Pd (5th column) at a distance of 20cm calculated from the friis transmission formula is far below the limit of 1 mW/cm².

Channel	Channel Frequency (MHz)	Output Peak Power to Antenna (dBm)	Antenna Gain (dBi)	Power Density at 20cm (mW/cm ²)	Limits (mW/cm ²)
Low	2402	2.11	0.63	0.00037	1
Middle	2441	1.76	0.63	0.00034	
High	2480	0.80	0.63	0.00028	

Note :

1. For 8DPSK mode.
2. The power density Pd (5th column) at a distance of 20 cm calculated from the friis transmission formula is far below the limit of 1 mW/cm².

The results shown in this test report refer only to the sample(s) tested unless otherwise stated. This test report cannot be reproduced, except in full, without prior written permission of the Company.