



User Manual

for S4335-AW series

S4343-AW/SZ4343-W

(S4335-AW/AWV, S4343-AW/SZ4343-W)

Digital Flat-Panel X-RAY Detector

Samsung Electronics Co., Ltd.

This manual is provided for the installation and operation of S4335-AW series , S4343-AW/SZ4343-W.

Please read this manual before the detector install and use.

© 2013 Samsung Electronics Co., Ltd. All rights reserved.



Table of Contents

- About this Manual 7
 - Symbols Used in This Manual 7
 - Intended for use 8
 - User Requirements 8
 - Service Center 8
- 1. Safety instructions 9
 - Safety Instructions 9
 - System Symbols 10
 - System Maintenance Checkpoints 12
 - General Safety 13
 - Electrical Safety 14
 - Mechanical Safety 15
 - Fire Safety 15
 - Safety from Explosion 15
 - EMC (Electromagnetic Compatibility) 15
 - Label 16
 - Maintenance, Cleaning and Disposal 16
 - Disclaimer 18
- 2. System Overview 19
 - System Overview 19
 - S4335-AW series 19
 - S4343-AW/SZ4343-W 19
 - System Purposes 19
 - Product components 20
 - Examination Room Components 21
 - Control Room Components 22
- 3. System Components 23
 - System Components 23
 - Detector 23
 - Power Supply Box 29
 - Main Cable 30

■	Battery Recharger	31
■	Battery	33
4.	Operating the System Hardware	36
●	Operating the System Hardware	36
■	Checking Connection	36
■	Operation	37
■	Operating description	38
5.	Specifications	39
6.	Appendices	40

Table 1 Special Symbol	11
Table 2 System Maintenance Checkpoints.....	12
Table 3 COMPONENTS.....	20
Table 4 LED STATUS.....	25
Table 5 POWER SUPPLY BOX DESCRIPTION	29
Table 6 BATTERY RECHARGER INDICATE LED.....	31
Table 7 CHECKING THE POWER STATUS OF COMPONENTS (S4335-AW series , S4343-AW/SZ4343-W).....	37
Table 8 POWER OFF STATUS	37
Table 9 OPERATING TIME TABLE.....	38

Figure 1 Examination Room Components	21
FIGURE 2. Battery Recharger.....	22
FIGURE 3 S4335-AW (CsI) & S4335-AWV (Gadox) Detector	23
FIGURE 4 S4343-AW/ SZ4343-W (CsI) Detector.....	23
FIGURE 5 Configuration of the Wireless Detector	24
FIGURE 6 DO NOT DROP	26
FIGURE 7 Location Considerations	26
FIGURE 8 Even Distribution of Weight.....	27
FIGURE 9 Localized Weight (Center).....	27
FIGURE 10 POWER SUPPLY BOX	29
FIGURE 11 MAIN CABLE.....	30
FIGURE 12 BATTERY RECHARGER	31
FIGURE 13 BATTERY INSERT.....	32
FIGURE 14 BATTERY	33
FIGURE 15 BATTERY INSTALLATION	33
FIGURE 16 BATTERY COVER INSTALLATION.....	34
FIGURE 17 BATTERY COVER REMOVAL.....	34
FIGURE 18 BATTERY REMOVAL.....	34
Figure 19 IP SET UP.....	36
FIGURE 20 POWER APPLIED COMPONENTS (S4335-AW series , S4343-AW/SZ4343-W).....	37
Figure 18: X-ray exposure & image acquisition	38

Hereby, SAMSUNG ELECTRONICS CO., LTD. declares that the radio equipment type S4335-AW series, S4343-AW/SZ4343-W are in compliance with Directive 2014/53/EU.

The full text of the EU declaration of conformity is available at the following internet address: <https://www.samsungmedicalsolution.com>



This product bears a CE marking in accordance with the provisions of the 93/42/EEC MDD.





About this Manual

■ Symbols Used in This Manual

The specifications and details of this manual may be changed in order to improve the product or to enhance its performance

The following symbols are used throughout this manual to alert the user to the relevant safety instructions or to any useful information when using this system

Symbol	Name	Description
	Warning	Indicates content which, if you fail to follow the accompanying instructions, may cause death or serious personal injury.
	Caution	Indicates content which, if you fail to follow the accompanying instructions, may cause personal injury or damage to the product.
	Note	Provides users with additional information on the topic for better understanding.

Please note that our company does not take responsibility for any accidents and is not obligated to do free repair service for any damage of the equipment due to the user's negligence which results from failure to follow the contents in this manual. Make sure you are familiar with the safety precautions and usage procedures. Also note that the product features may slightly differ from the contents of this manual depending on the specifications.

■ Intended for use

S4335-AW series, S434AW/SZ4343-W, Digital Flat Panel X-Ray Detector are indicated for digital imaging solution designed for providing general radiographic diagnosis of human anatomy targeting both adult and children. It is intended to replace film based radiographic diagnostic systems and provide more precise case diagnosis and treatment planning on a real time basis for physicians and radiologists. Not to be used for mammography and direct cardiac application.

■ User Requirements



CAUTION

- This equipment should be only operated by users who have received professional medical education and training, such as physicians, radiologists, and other medical specialists.
- Please read the user manual and the safety information carefully before using this equipment. Operating the equipment without reading the safety information may result in personal injury to the patient or to yourself.

■ Service Center

- Korea : Service Center 080-022-9797

Head Quarters

- 129 Samsung-ro, Yeongtong-gu, Suwon-si, Gyeonggi-do, Korea

■ Contact Information



SAMSUNG ELECTRONICS Co., LTD.

129, Samsung-ro, Yeongtong-gu, Suwon-si, Gyeonggi-do, Korea

EC REP SAMSUNG ELECTRONICS (UK) LTD.

Blackbushe Business Park Saxony Way, Yateley, Hampshire GU46 6GG, UK

1. SAFETY INSTRUCTIONS



Safety Instructions

□ In this chapter, information of safety instructions and regulations are provided. It is provided to protect users of the system from unintended safety hazard and prevent property damage, please read thoroughly and keep instructions. If additional training is required, consult your dealer or the service center of the manufacturer.













WARNING

□ Before using this system, please read safety instructions thoroughly. The manufacturer is not responsible for any damages and accidents caused by violating such safety instructions or regulations.

■ System Symbols

Table 1 shows the symbols related to maintaining the safety of the patient and the user.

	Alternate current
	Direct current
	Protective earth (Ground)
	Off (power : disconnect from the main switch)
	On (power : connect to the main switch)
	Identifies terminals which, when connected together, bring various parts of a piece of equipment or of a system to the same potential.
	Indicates content which, if you fail to follow the accompanying instructions, may cause personal injury or damage to the product.
	Indicates that the dangerous factors can be occurred caused by High Voltage.
	Indicates that the accompanying operating instructions in the manual must be followed to operate the equipment safely.
	TYPE B Applied part
	Marks it contains radio transmitting device.







	Avoid contact with water
	No unauthorized or unlawful modification
	Waste electrical and electronic equipment (WEEE)
	Temperature limitation
	Marks fragile device that requires full attention when handling.
	Manufacturer
	EC Representative

Table 1 SPECIAL SYMBOL

■ System Maintenance Checkpoints

To ensure the system performance and usability along with safety, regular maintenance and checking the condition are required. To secure safety of both patient and operator and to ensure the performance of the system, check the system on a regular interval. For periodic inspection of the system, consult your dealer or the manufacturer's service center.

No.	Item	Category	Checkpoints	Check Interval	Remark
1	Noise / Vibration	In use	Check noise and vibration from each operating parts of the system.	1 year	
2	Power Supply box	While in use	Check the power supply box voltage while the equipment s turned off.	1 year	
3	Appearance	While in use	Run a visual inspection to check if the appearance shows any abnormalities, such as loosened bolts or had grips, transformation, etc. while the equipment is turned off.	1 year	
4	Cables	Before Using	Check cable runs for worn out cables, damage or short circuited, broken wires, etc. while the equipment is turned off.	6 months	
5	Grounding	While in use	Check the earth-grounding is intact, not broken or loosened terminal. (Grounding resistance should be below 0.1Ω.)	1 year	
6	Installation Checkpoints	When Installing	When installing, check that the equipment is leveled and firmly fixed.	1 year	

Table 2 SYSTEM MAINTENANCE CHECKPOINTS



WARNING

- When inspecting on checkpoints requiring no power, please make sure to keep the system turned off.

Classification

- The type of protection against electric shock: Class I equipment
- The degree of protection against electric shock: Type B applied part
- The degree of protection against ingress of water: Ordinary equipment
- The method(s) of sterilization or disinfection: Not applicable
- The degree of safety of application in the presence of a FLAMMABLE ANAESTHETIC MIXTURE WITH AIR or WITH OXYGEN OR NITROUS OXIDE: Not applicable
- Mode of operation: As momentary continuous operation

■ General Safety

□ Before using the equipment, the user should check that:

- All components are connected correctly.
- All components are operational when the system is powered on.
- Neither the patient nor the user is present in the examination room when powering the equipment on.



□ If any electrical or mechanical fault occurs, stop using the system immediately.

You can identify faults from the display or warnings.



□ Please consult the manufacturer before connecting a component from another system to this system. Any auxiliary device connected to the system must be IEC certified (data processing equipment: IEC60950-1, medical electrical equipment: IEC60601-1). Also, if the auxiliary device is connected to a signal I/O port, it should comply with IEC60601-1 and/or IEC60601-1-1.



Do not connect the instrument with anything other than specified. Otherwise, it may result in fire or electric shock.



□ Medical equipment requires periodic maintenance and management. For more information, refer to 1. Maintenance, Cleaning and Disposal.



□ If an error message appears while the system is in use, it may stop operating. When an error message appears, contact the service center



□ The manufacturer will not accept liability for:

- Fault, damage or personal injury incurred as a result of the user incorrectly performing maintenance on the system
- Personal injury incurred due to the user's carelessness
- Fault, damage or personal injury incurred due to use of an ancillary device which is not provided by the manufacturer.

□ When Problem Occurs



Should any of the following occur, immediately turn OFF the power of each instruments, unplug the power cable from the AC outlet, and contact SAMSUNG representative or distributor.

- When there is smoke, odd smell or abnormal sound.
- When liquid has been spilled into the instrument or a metal object has entered through an opening.
- When the instrument has been dropped and it is damaged.



□ This detector should be used by selected users. If not you fully aware of the factor of exposure, the manual, and the schedule of organization, This could be dangerous for the patients and users.



□ Do not keep patient contact for a long time for safe use.

Surface maximum temperature:41.3°C (Conditions with an ambient temperature of 35°C)

■ Electrical Safety



WARNING

□ In compliance with IEC 60601-1, this medical equipment complies with the requirements for Safety class I, type B.



WARNING

□ This system must be used in an environment complying with the requirements of the IEC.



WARNING

□ Do not remove the safety cover of this system needlessly. When it is removed, the high voltage current inside the system may cause electric shock.



WARNING

□ Be careful to ensure that no liquids enter the system.



WARNING

□ If chemicals are spilled or evaporate, it may result in fire or electric shock through contact with electric parts inside the instruments. Also, some disinfectants are flammable. Be sure to take care when using them.



WARNING

□ Be sure to turn OFF the power of each instrument before connecting or disconnecting the cables. Also, do not handle them with wet hands. Otherwise, you may get an electric shock that may result in death or serious injury.



WARNING

□ Do not cut or process the cables. Also, do not place anything heavy, including the instrument on it, step on it, pull it, bend it, or bundle it. Otherwise, the cable may be damaged, which may result in fire or electric shock.



WARNING

□ Be sure to hold the plug or connector to disconnect the cable. If you pull the cable, the core wire may be damaged, resulting in fire or electric shock.



WARNING

□ Do not turn ON the system power when condensation is formed on the instrument. Otherwise, it may result in fire or electric shock.



WARNING

□ Do not spill liquid or chemicals onto the instrument or, in cases where the patient is injured, do not allow it to become wet with blood or other body fluids, as doing so may result in fire or electric shock. In such situation, protect the instrument with disposable covering as necessary.

For safety reasons, be sure to turn OFF the power of each instrument when the inspections indicated in this manual are going to be performed. Otherwise, it may result in electric shock.

When the instrument is going to be cleaned, be sure to turn OFF the power of each instrument, and unplug the power cable from the AC outlet. Otherwise, fire or electric shock may result.



WARNING

□ Never disassemble or modify the product as it may result in fire or electric shock. Also, since the instrument incorporates parts that may cause electric shocks and other hazardous parts, touching them may cause death or serious injury

■ Mechanical Safety



- Never remove the cover (Detector, Power Box, Recharger, Battery Pack, and Adapter) or cables unless directed to do so by a professionally trained engineer.



- When an examination is in progress, auditory and visual communication between the patient and the system user must be possible at all times.



- Be careful not to pinch any part of your or the patient's body or clothing while using the system.



- Do not hit or drop the instrument. The instrument may be damaged if it receives a strong jolt, which may result in fire or electric shock if the instrument is used without it being repaired.

■ Fire Safety



- Do not operate the system in a location where there is a danger of fire.



- In the event of a fire, stop the entire system immediately and disconnect the power cable. Make sure to extinguish the fire with a carbon dioxide fire extinguisher

■ Safety from Explosion



- Do not operate the system in a location where there is a danger of explosion. This system is not designed to be used in a location where there is a danger of explosion, and does not comply with the AP/AGP standard.

■ EMC (Electromagnetic Compatibility)



- Do not use any wireless devices, including cellular phones, near the system. All wireless devices, whether they comply with the EMC standard or not, may emit electromagnetic interferences and cause the system to malfunction when they are used nearby.



- When using this system on a patient with an implantable pacemaker or an implantable cardioverter defibrillator, the patient must be informed that continuous X-ray exposes in pulse form may cause the pacemaker or cardioverter defibrillator to malfunction. When using this system, ensure that X-rays are not exposed directly onto the patient's implantable pacemaker or cardioverter defibrillator, and that the exposure time is kept as short as possible.



- This equipment should not be used adjacent to or stacked with other equipment; if adjacent or stacked use is necessary, the equipment must be tested and verified in order to ensure it operates normally in the configuration in which it will be used.

■ Label



- For information on the types and attachment locations of the Detector Component labels, refer to Labels.

■ Maintenance, Cleaning and Disposal

➤ Maintenance

- Inspect the equipment periodically for patient and user safety.
- The instrument must be repaired by a qualified engineer only. If it is not repaired properly, it may cause fire, electric shock, or accident.

The S4335-AW series, S4343AW/SZ4343-W are rated IP54 of water-resistant and dustproof according to IEC 60529 standard.

- Despite this classification, S3025-W is not impervious to water damage in any situation. It is important that all compartments are closed tightly.
- Follow these tips carefully to prevent damage to the detector
 - Whenever your device gets wet, dry it thoroughly with a clean, soft cloth.
 - Do not expose the detector to salt water or ionized water.
 - IP54 of water-resistant and dustproof is only guaranteed in case of all covers are closed tightly and in wireless mode, disconnected from tether.
 - Battery cover is consumable parts ,so these parts should be replaced periodically
 - Covers may be loosened slightly if the detector is dropped or receives an impact. Ensure that all the covers are properly aligned and tightly closed. Otherwise, they may not provide protection from water and dust.

➤ Cleaning



- Always turn off the equipment completely before cleaning.



- Do neither open the cover nor insert liquids into the system.



- When cleaning the exterior of the system, use a soft cleaning cloth dampened with tepid Water and soap. Do not use detergents or chemical solutions.



- While a maintenance personnel is cleaning the room, cables connected to the equipment may be lifted or pulled.

When lifting , or pulling cables, the connection with the equipment may be disconnected causing malfunction, electric shock, or danger of fire. Also, water may be absorbed into the equipment if mopped with a damp cloth, which may cause electric shocks or fire.



- If the equipment generates abnormal noises, contact the service center immediately. The user must not arbitrarily disassemble, repair, or modify the equipment. Fire or electric shock may result.



- Always be sure to keep checking the condition of the system and the patient to ensure they are normal during the use of the instrument. If any problem is found, take appropriate measures, such as stopping the operation of the instrument, as required.

➤ Correct Disposal of This Product (Waste Electrical & Electronic Equipment)

(Applicable in countries with separate collection systems)



This marking on the product, accessories or literature indicates that the product and its electronic accessories should not be disposed of with other household waste at the end of their working life. To prevent possible harm to the environment or human health from uncontrolled waste disposal, please separate these items from other types of waste and recycle them responsibly to promote the sustainable reuse of material resources.

Household users should contact either the retailer where they purchased this product, or their local government office, for details of where and how they can take these items for environmentally safe recycling.

Business users should contact their supplier and check the terms and conditions of the purchase contract. This product and its electronic accessories should not be mixed with other commercial wastes for disposal.

➤ Environment of Use and Storage



□ Does not use or store the instrument near any flammable chemicals such as alcohol, thinner, benzene, etc. Also, this instrument is not a category AP or APG equipment. If chemicals are spilled or evaporate, it may result in fire or electric shock through contact with electric parts inside the instruments. Also, some disinfectants are flammable. Be sure to take care when using them.



□ Do not install the instrument in a location with the conditions listed below. Otherwise, it may result in failure or malfunction, fall or cause fire or injury.

- Close to facilities where water is used.
- Where it will be exposed to direct sunlight.
- Close to air-conditioner or ventilation equipment.
- Close to heat source such as a heater.
- Prone to vibration.
- Insecure place.
- Dusty environment.
- Saline or sulfurous environment.
- High temperature or humidity.
- Freezing or condensation.

Do not place the storage case in a location with the conditions listed below.

- Where the cable of the sensor unit will be strongly pulled when the sensor unit is put into the case, otherwise, the cable may be damaged, resulting in fire or electric shock.
- Where someone might get their foot caught in the cable of the sensor unit is put in the case. Otherwise they could trip over, resulting in injury.

■ Disclaimer

- The manufacturer assumes no liability for any failure or damage which may occur by using other company's products
- The manufacturer assumes no liability for any failure or damage that may occur from installing, relocating, modifying, maintaining, or repairing the equipment by any personnel other than designated personnel by the manufacturer.
- The manufacturer assumes no liability for any accidents or damage on the equipment which may occur due to operations performed without following the relevant precautions or instructions in this manual..
- The manufacturer assumes no liability for any failure or damage due to natural disasters such as fire, earthquake, flood, and lightning.
- The manufacturer assumes no liability for erroneous diagnostic criteria or results.
- The manufacturer assumes no liability for any failure or damage which may occur due to operations performed for any purposes other than its intended use.
- This equipment should be operated under the specified conditions. The manufacturer assumes no liability for any failure or damage which may occur due to operations performed under conditions other than those specified in this manual. For more information on the operating conditions, refer to Appendices.

2. SYSTEM OVERVIEW

System Overview

■ S4335-AW series

Divided into 2 models

1. S4335-AW : CsI Detector

43 x 35 cassette-sized detector with Cesium Iodide (CsI:TI) for scintillator material

2. S4335-AWV : Gadox Detector

Scintillator material changed to Gadolinium Oxy-sulfide ($Gd_2O_2S:Tb$)

on the basis of S4335-AW

■ S4343-AW/SZ4343-W

Divided into 2 models

1. S4343-AW/ SZ4343-W : CsI Detector

43 x 43 cassette-sized detector with Cesium Iodide (CsI:TI) for scintillator material

■ System Purposes

The S4335-AW series, S4343AW/SZ4343-W are a portable digital X-ray flat panel wireless detector that can generate Images of any part of the body. This X-ray imaging system consists of an X-ray detector (an a-Si TFT sensor panel with scintillator), a power supply box, a battery recharger, battery packs and a main cable.

The S4335-AW series, S4343AW/SZ4343-W series can be used for radiographic imaging of human body parts such as head, Chest, spinal, abdominal, particular, hand, foot, and other internal organs. However, do not use the system for mammography purposes.

Radiated X-rays through the body is processed to produce radiography by the detector. Converted electric signal is processed by the signal processor to amplify and digitize data And the result is transferred to the workstation.

■ Product components

Item	Part Name	Product Name	Qty	Description
1	Detector	S4335-AW	1	X-ray flat panel detector
		S4335-AWV		
		S4343-AW		
		SZ4343-W		
2	Power Supply Box	DEPS9601	1	Source of necessary electricity
		DEPS9601A		Source of necessary electricity With DC power Input
3	Battery Recharger	MSP-90W-12VC	1	To recharge an extra battery
4	Battery Pack	ELT-3S1PA	2	Source for wireless connection
5	Recharger Adaptor	AD-9019A	1	Source of the battery pack recharger
6	Main Cable	MI-44-01043A	1	To connect x-ray detector with Power Supply Box
7	AC Adapter Cable (Optional)	-	1	AC 110 / 220V power cable For battery pack recharger adaptor

Table 3 COMPONENTS

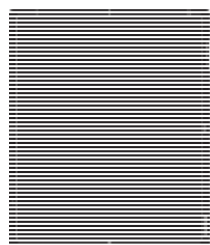

1. Detector



2. Power Supply Box

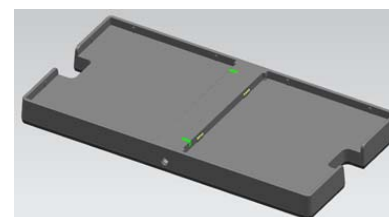

3. Battery pack Recharger



4. Battery pack



5. Recharger Adapter



6. Main Cable



7. AC Adapter Cable
(Optional)



Regularly changed parts : nothing

■ version

	Item	version
1	Detector hardware	R0
2	Detector software	V1.0
3	WLAN Module software	V4

■ Examination Room Components

The components of The S4335-AW series, S4343AW/SZ4343-W can be divided into the examination room components and the control room Components in accordance with their installation locations.

The below figure 1 shows S4335-AW series , S4343-AW/SZ4343-W Examination Components.



Figure 1 EXAMINATION ROOM COMPONENTS

All examination room components of the system should be used inside a shielded environment.

■ Control Room Components

The control room for S4335-AW series , S4343-AW/SZ4343-W are configured as shown in Figure 2.

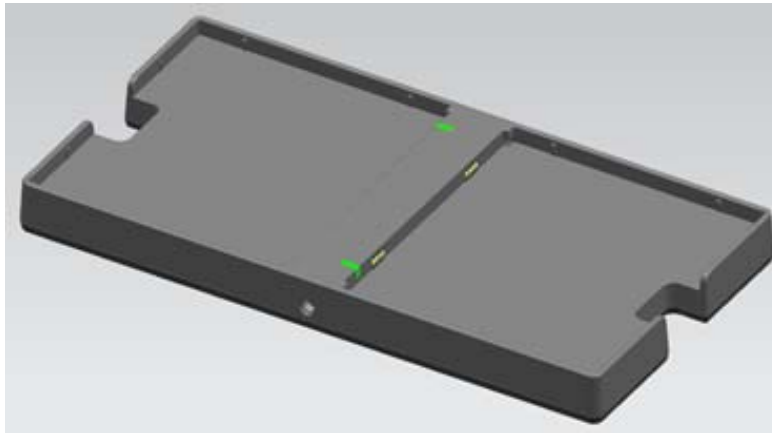

FIGURE 2. Battery Recharger

■ Integration Information

Samsung Digital X-ray systems

3. SYSTEM COMPONENTS

■ System Components

■ Detector

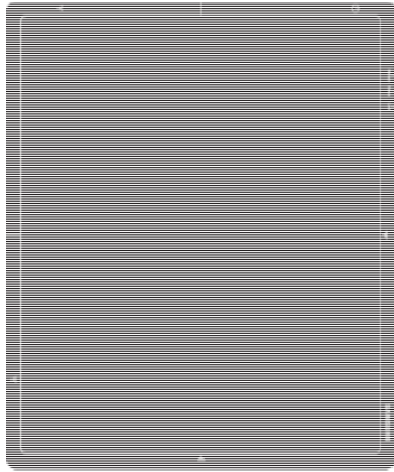

FIGURE 3 S4335-AW (CSI) & S4335-AWV (Gadox) Detector

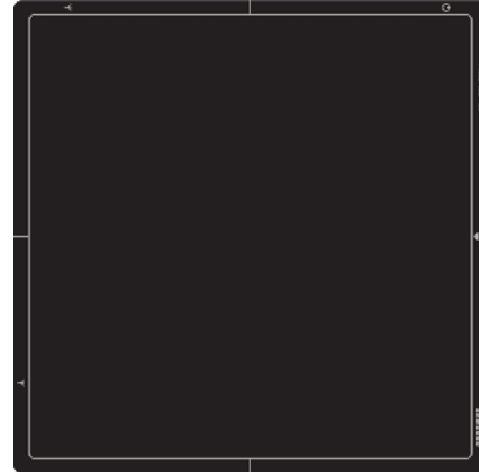

FIGURE 4 S4343-AW/ SZ4343-W (CSI) Detector

Note. S4335-AW is only different from S4335-AWV in a color of the front-side decoration sheet at appearance design.

This Flat-Panel, wireless digital X-ray detector is designed for generating images of any part of the body. It makes high-resolution, high-sensitive digital images.

➤ Overview

The S4335-AW series, S434AW/SZ4343-W are a portable digital x-ray flat panel detector that can generate images of any part of the body. This x-ray imaging system is based on amorphous silicon sensor pixels arrayed on a flat panel for X-ray image acquisition. It makes high-resolution, high-sensitive digital images.

➤ Product features

- Based on a-Si TFT active matrix
- Compact (15 mm thickness) and light weight
- High resolution : ~ 3.57 lp/mm
- 16-bit digital output
- Easy integration

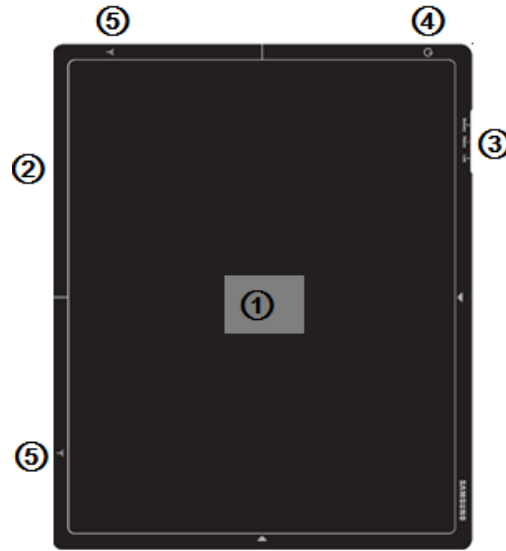

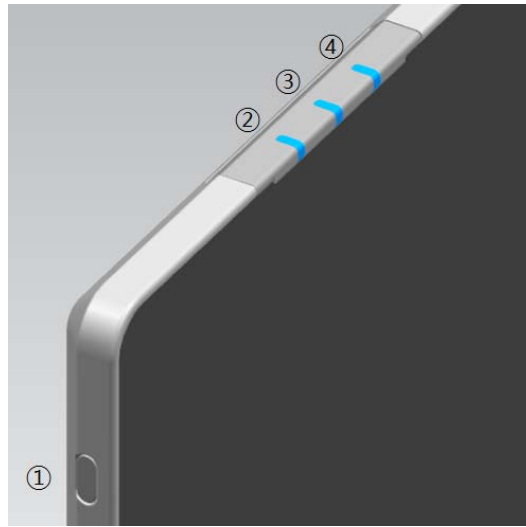



FIGURE 5 Configuration of the Wireless Detector

No.	Name/Function	Description
①	Detection Area	This area converts the X-rays passing through the patient into images. Any part of the body outside the detection area will not be captured.
②	Detector Cable	This cable is used for power supply and signal transmission.
③	LED	This LED indicates the power status.
④	Power Switch	Turns on the power.
⑤	Antenna	 Antenna Symbol for wireless connection. - The antenna is located under the symbol.



No.	Name/Function	Description
①	Power Switch	<ul style="list-style-type: none"> Power on / off button
②	Power Status Indicator	<ul style="list-style-type: none"> When Powering On: The LED indicator is on. When Remaining Battery Status 26% to 100% : LED color Green. When Remaining Battery Status 6% to 25% : LED color Yellow. When Remaining Battery Status Less than 5% : LED color Red. When Powering Off: The LED turns off.
③	Intended Process Status Indicator	<ul style="list-style-type: none"> When registered in the system and in the Paring state : LED indicator is on. When the detector is selected for exposure : LED Indicator blinks. (The LED indicator colors are Yellow , Magenta, Blue, Cyan.)
④	Interface Link Indicator	<ul style="list-style-type: none"> Wired Mode: <ul style="list-style-type: none"> General : The green LED Indicator Periodically blinks. H/W Signal Check : The green LED Indicator Aperiodically blinks. Wireless Mode: The green LED indicator is on.

Table 4 LED STATUS

 In the case of a S4335-AW series , S4343-AW/SZ4343-W detector, the LED indicator may be different depending on the particulars of the product.

Notes for Using the Detector

- Handling



WARNING:

- Using the detector while other electronic devices are being operated nearby may affect the performance of the detector. If you use other wireless equipment that has similar frequencies, such as smartphones, at the same time as the detector, the detector may experience wireless connection issues. Capturing images while the Auto Bed or Moving Grid is operated may affect the results.
- Do not pull the cable by force. If the cable is tangled, do not pull the detector body by force. Otherwise, the cable may become damaged, resulting in electric shock.

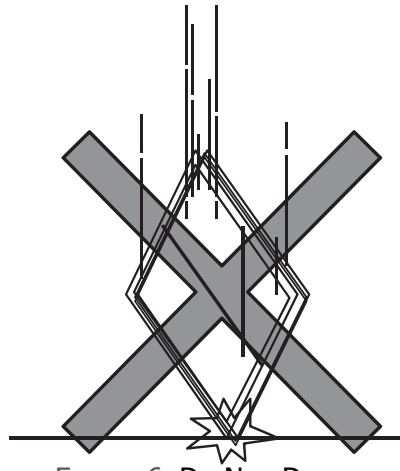

FIGURE 7 Location Considerations



WARNING:

- Be careful not to strike, drop, or cause any impact to the detector. When using the detector ensure that it is placed on a flat surface otherwise the detector may be bent or be caused to malfunction.
- There would be damage if the detector is partly pressed without battery mounted. It is recommended to use it with battery mounted in both wired and wireless mode.



CAUTION: Precautions When Connecting Detector and Cable

- If foreign material has adhered to the connector between detector and cable, image transmission time is likely to be delayed. Follow the cleaning tips below to clean the connectors.
- Be careful to ensure that metal or other conductive material does not adhere to the pin connector of both the detector and the cable.
- Remove any conductive material on the detector magnet and cable using sticky tape.
- Clean the detector's pin connector of using a commercial plastic brush to avoid damage to the pins.

- BEFORE X-RAY EXPOSURE

A sudden change in the temperature of the examination room may cause moisture to build up in the wireless detector. In the event of this happening, do not use the wireless detector until all of the moisture is removed. Using the wireless detector with moisture in it may result in unstable system operation. If air-conditioning is available, decrease the temperature gradually to reduce the temperature difference between the wireless detector and the examination room to prevent moisture build-up.

- WEIGHT GUIDE

The wireless detector is not designed to support patients. Therefore it must be placed on a flat surface when weight needs to be applied to its surface. Be careful not to damage the wireless detector by applying excessive weight.

- Even Distribution of Weight

Patients' weight should be uniformly distributed across the detector's surface. It should not be concentrated in one place.

- Localized Weight

When performing weight-bearing protocols, a patient should not stand on the detector without the 'Weight Distribution Cap'.

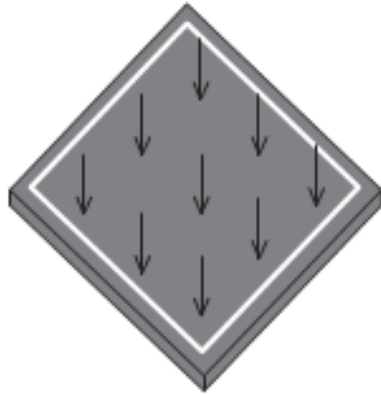

FIGURE 8 Even Distribution of Weight

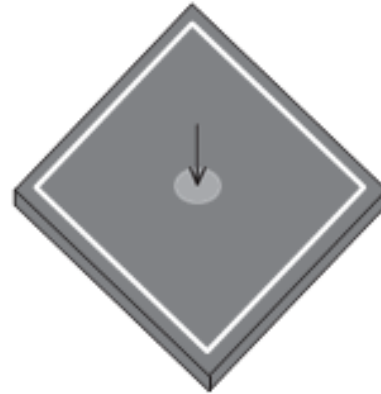

FIGURE 9 Localized Weight (Center)

- During Exposure

Do not apply excessive weight to the sensor unit. Otherwise, the sensor may be damaged.

The detector and patient must be taken from a fixed state. Otherwise, the performance may be degraded.

- Others



- Be sure to reconnect the cables to the proper connectors. Otherwise, the instrument may malfunction or may be damaged.



- Never use with other power supplies and cables. Use DEPS9601 or DEPS9601A only

- During Cleaning

- You must turn the detector off before cleaning or disinfecting it and wait until the detector is completely dry before turning it on and using it again.
- Recommended detergent to use should be neutral, containing 15–40% concentrated hydrogen peroxide and 70% concentrated isopropyl alcohol.
- Do not use corrosive, solvent, or gas disinfectants.
- Clean the exterior of the detector with a soft cloth damp with lukewarm water mixed with a neutral detergent.
- Do not leave a damp cloth on top of the detector for more than 1 minute. This is to prevent the detergent from flowing into the interior of the detector.
- Do not directly pour or spray detergent onto the detector. Especially protect the main cable and battery connector from liquids.
- To reduce the risk of infection while using the detector, the use of disposable plastic bags is recommended.

- Maintaining Water and Dust Resistance

The S4335-AW series, S4343AW/SZ4343-W are rated IP54 water-resistant and dustproof according to IEC 60529 standard.

Despite this classification, S3025-W is not impervious to water damage in any situation. It is important that all compartments are kept tightly closed. Follow these tips carefully to prevent damage to the detector.

- Whenever your device gets wet, dry it thoroughly with a clean, soft cloth.
- Do not expose the detector to salt water or ionized water.
- The IP54 water-resistant and dustproof rating is only guaranteed if all covers are closed tightly and the detector is in wireless mode and disconnected from tether.
- The battery cover is consumable parts, so these parts should be replaced periodically.
- Covers may be loosened slightly if the detector is dropped or subject to an impact. Ensure that all the covers are properly aligned and tightly closed. Otherwise, they may not provide protection from water and dust.

- Storage

To reduce the risk of infection while using the detector, the use of disposable plastic bags is recommended.



WARNING: Be careful not to damage the wireless detector by using it on or adjacent to a protruding part of the floor. Always make sure that it used on a flat floor.



To prevent the detector from being damaged by excessive force, we recommend that you purchase the optional 'Weight Distribution Cap' and use it to protect the detector. (Patients should not stand on the detector without the 'Weight Distribution Cap'.)

■ Power Supply Box

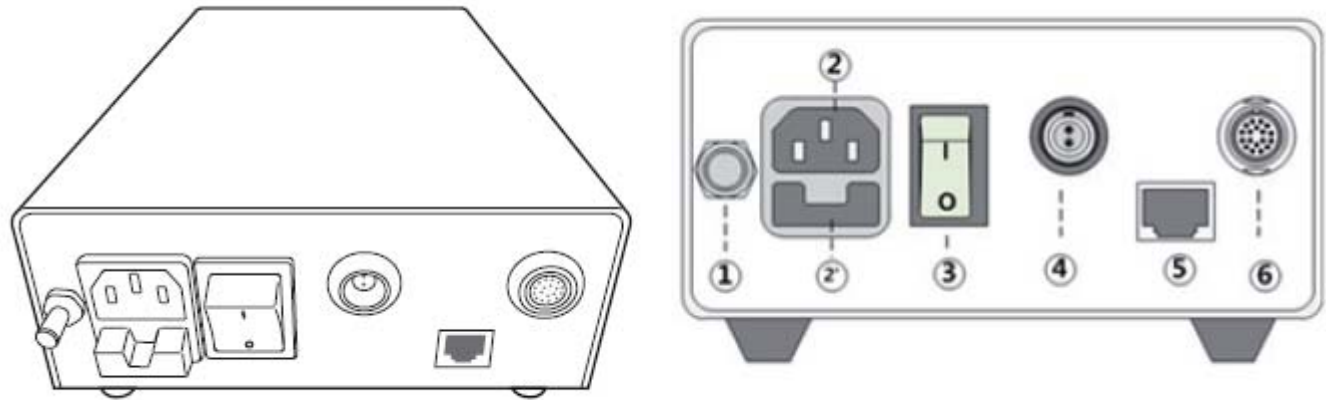

FIGURE 10 POWER SUPPLY BOX

Item	Description
Power Supply Box	<p>① Earth GND: Connects the power supply box to the ground.</p> <p>② Inlet (100-240 Vac): Supplies power to the power supply box.</p> <p>Fuse: Protects the power supply box from overvoltage.</p> <p>③ Switch: Turns the power supply box on and off.</p> <p>④ DC24V INPUT※Only DEPS-9601A</p> <p>⑤ LAN Port: Connects to the LAN cable.</p> <p>⑥ Main Cable Connector: Supplies power to the detector.</p>

Table 5 POWER SUPPLY BOX DESCRIPTION

■ Main Cable

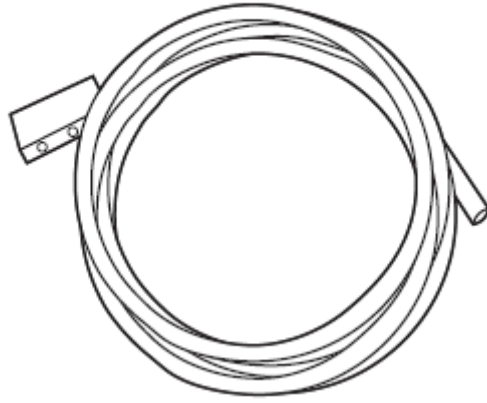

FIGURE 11 MAIN CABLE

This cable connects the detector to the power supply box.



Because the instrument's cable is long, take care so cables do not get tangled during use.

Also, be careful not to get your feet caught in the cable.



Do not pull the cable by force. And If the cable gets tangled, do not pull the main body of portable detector by force. Otherwise, the cable is damaged and causes fire or electric shock.

■ Battery Recharger

The battery recharger is used for S4335-AW series, S4343-AW/SZ4343-W . You can recharge the battery and check the charge condition.

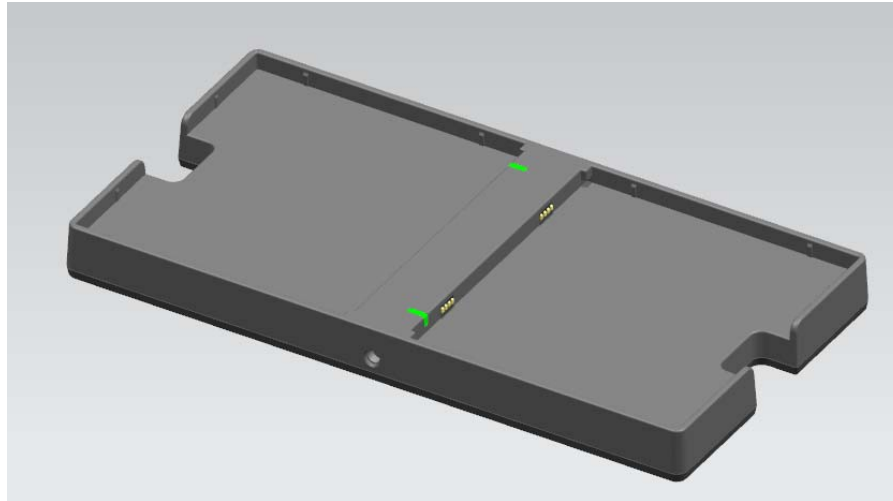

FIGURE 12 BATTERY RECHARGER

1. LED: Indicates the condition of charge. This is turned off when the power is disconnected or is not recharged.
2. The Battery recharger Terminal

Indicates as follows When the battery recharges, When the battery is recharging, it changes red into green according to the level of charge.

LED	The status of battery Recharger
• Red	• Fast charging mode (Until About 90%)
• Green	• Normal charging mode (About 85% ~ 100 %)
• Blue	• The error of charging

Table 6 BATTERY RECHARGER INDICATE LED



If LED light is blue during recharging the battery, stop recharging the battery immediately and check whether there are Impurities or not in the battery recharger Terminal.

Despite taking action on upper step, if LED light is still blue, stop recharging the battery.

➤ The use

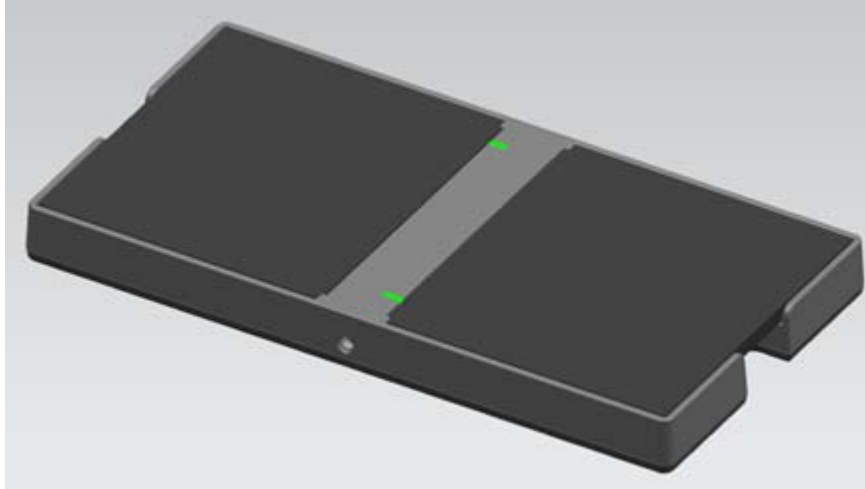

FIGURE 13 BATTERY INSERT

After the Adaptor (AD-9019A) connects to Power cord, be sure to connect it to Adaptor terminal on the back side of Recharger

Tilt the top part of the battery tightly and insert the battery to press to be placed on the battery recharger safely.



- When using the S4335-AW series, S434AW/SZ4343-W battery recharger, always use the battery (ELT-3S1PA) provided by Samsung Electronics Co. Ltd..



- When using Battery recharger, Be sure to use Adapter (AD-9019A) Provided by Samsung Electronics Co. Ltd..
- When moving the S4335-AW series, S434AW/SZ4343-W battery recharger, always separate the power and battery pack



- When using the S4335-AW series, S434AW/SZ4343-W battery recharger, Always be cautious about touching liquid, impurities. In case of short trouble.

- Do not disassemble the battery recharger.



- When using the S4335-AW series, S434AW/SZ4343-W battery recharger, be sure to comply with the user environment. The performance of S4335-AW series, S434AW/SZ4343-W battery can be down and the durability can be shorter.



- Be sure to use the S4335-AW series, S434AW/SZ4343-W battery recharger in the Control Room. This battery recharger is not designed to use in the Examination Room.



- When not using the S4335-AW series, S4343-AW/SZ4343-W battery recharger for a long time. Always do separate the battery recharger from the Power.



- When inserting the battery to the battery recharger, Be careful of being caught clothes or impurities.

■ Battery



FIGURE 14 BATTERY

① Battery terminal part



- When the battery use period is much shorter than the usual use time, replace the battery.
- When the battery is not used for a long time, charge the battery and disconnect the power.



CAUTION: Warning for using the lithium ion battery. Mishandling of the battery may cause heat, fire, explosion, and/or deterioration. Be sure to observe the following guidelines:

- If the battery has to be stored for a long period, it should be removed from the application (detector and recharger) and stored in a place where the humidity and temperature are low.
- Do not use the battery in a high static energy environment where the protection device can be damaged.
- Do not expose the battery to direct sunlight or high heat (such as fire).

➤ Battery/Battery Cover Installation

Tilt the top part of the battery tightly and insert the battery to press to be placed on the detector safely.

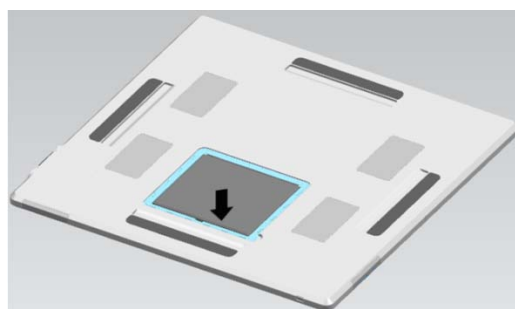
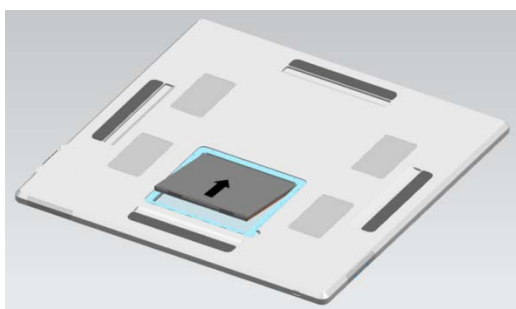

FIGURE 15 BATTERY INSTALLATION

Place the battery cover on the seat so that the inner hook of the cover is fastened to the seat groove. Click the down arrow area.

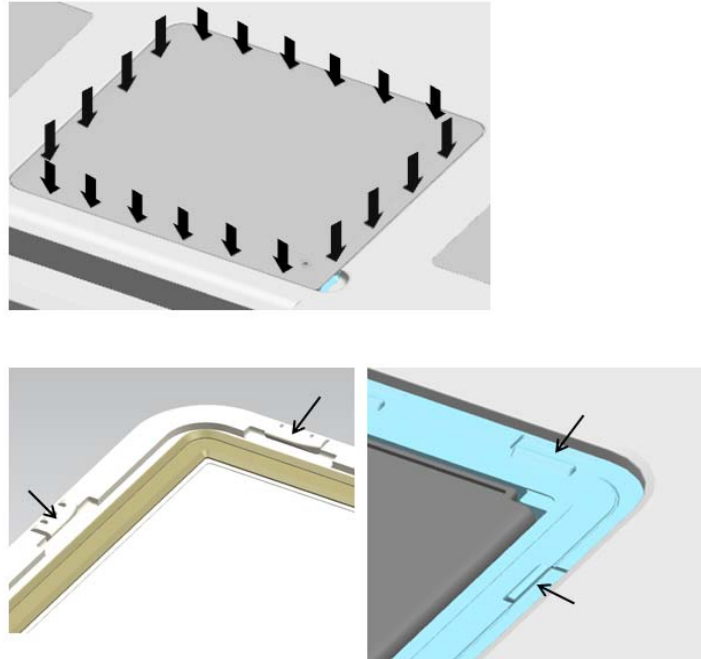

FIGURE 16 BATTERY COVER INSTALLATION



WARNING:

- Before closing the cover, ensure that there is not any foreign substance such as dust or sand between the rubber on the back of the cover and sealing area.
- The S4335-AW series, S434AW/SZ4343-W are rated IP54 of water-resistant and dustproof according to IEC 60529 standard. Ensure that battery cover must be tightly closed in order to maintain water and dust resistance of IP54. Opened or loosed cover may allow water and dust to enter the device and cause damage.

➤ **Battery/Battery Cover Removal**

Put fingers in the cover release groove and remove the battery cover.

FIGURE 17 BATTERY COVER REMOVAL

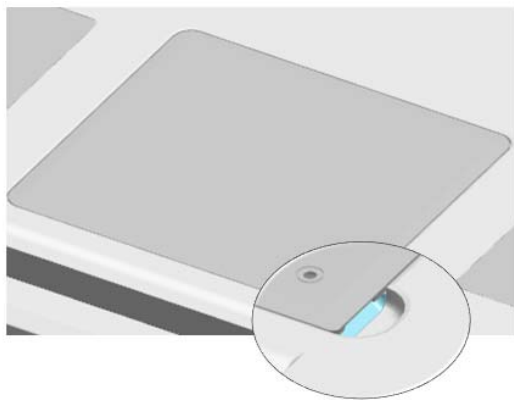

Remove the battery by lifting the battery using the battery release groove.

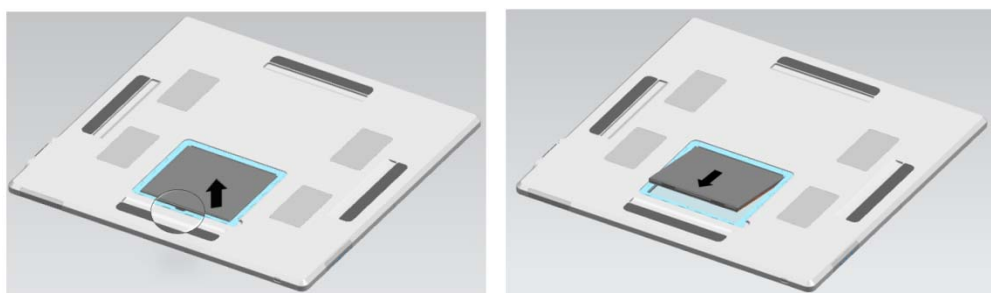

FIGURE 18 BATTERY REMOVAL



- Be sure to recharge the battery by using the S4335-AW series , S4343-AW/SZ4343-W (Detector) or the battery recharger (MSP-90W-12VC) provided by Samsung Electronics Co. Ltd..



- If the battery is needed to be stored for a long period, battery should be removed from the application and stored in a place where humidity and temperature are low.



- While the battery is charged, used and stored, keep it away from object materials with static electric chargers.



- If the terminals of the battery become dirty, wipe with a dry cloth before using the battery.



- Be sure to use the battery in the environment designated by Samsung. Otherwise, the life of battery can be short



- Stop using the battery if the battery becomes abnormally hot, disorder, discoloration, deformation, or abnormal conditions is detected during use, charge, or storage.



Don't short circuit (+) and (-) terminals with metallic object intentionally.



- Not be sure to touch liquid on the surface of the battery.



Don't pierce the battery with a sharp object such as a needle, screw drivers.



- Do not hit the battery with heavy objects.



- Don't step on the battery and throw or drop the battery on the hard floor to avoid mechanical shock.



- Don't disassemble the battery or modify the battery design including electric circuit.

4. OPERATING THE SYSTEM HARDWARE

■ Operating the System Hardware

■ IP set up

[My Network Places] → [Properties] → [Local Area Connection] → [Properties] → [Internet Protocol (TCP/IP)]

→ [Use the following IP address]

IP address : 192 . 168 . 197 . 20 (Console PC)

Detector IP address is 192. 168. 197. 80 (default)

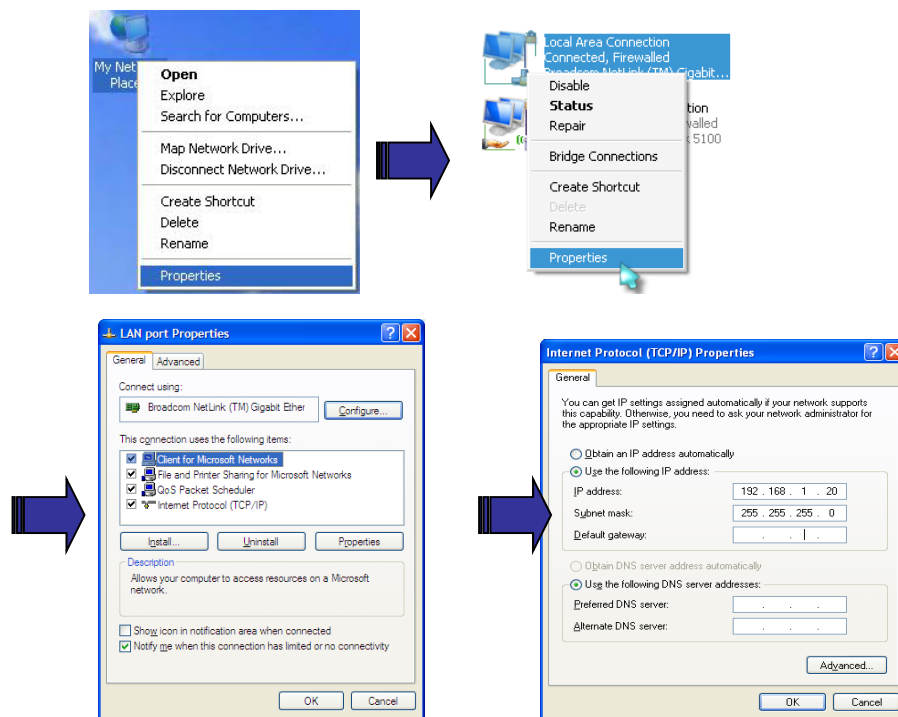

Figure 19 IP SET UP

It is possible to change IP address, but it shouldn't be the same as the detector IP address.

■ Checking Connection

Check LED on the detector & power supply

Ping test: [Start] → [Run] → ping -t 192.168.197.80

■ Operation

➤ Switching power on / off

This equipment is turned on by the Power Button of each component.

Table 9 lists the methods for checking the power on status of the system components.

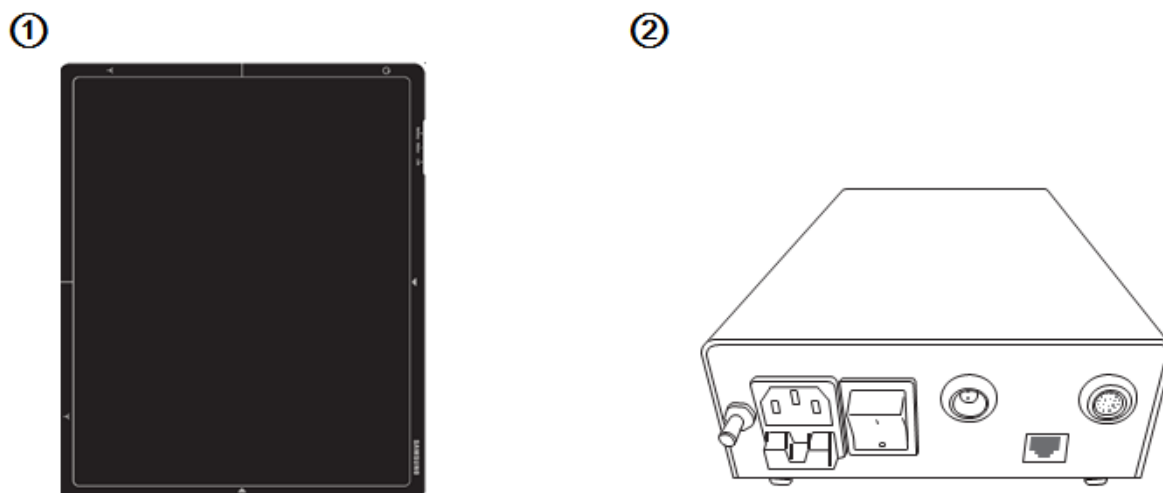

FIGURE 20 POWER APPLIED COMPONENTS (S4335-AW series , S4343-AW/SZ4343-W)

Component	Power button location	To check the power status
Detector	Power switch on the bottom of the right side	Dimming blue power LED
Power supply Box	The front side of Power supply box	Green power LED

Table 7 CHECKING THE POWER STATUS OF COMPONENTS (S4335-AW series , S4343-AW/SZ4343-W)

All connection should be done, before turn on the power supply box.

Turn on the power of the detector power supply box, workstation.

The green light of the LED indicator on the detector is on, the detector power is on.

The blue light of the LED indicator on the detector is blinking, the detector is getting prepared to work and initialize.

Turn off the power of the detector power supply box

When Detector is not turned on, be sure to check the Connection, the status of Battery and installation at first.



Below table 10 for turning off each component.

Component	Power Button Location	To check the power status
Detector	On the bottom of the right side	Blue power LED is turned off.
Power supply	The front side of PSU	Green power LED is turned off.

Table 8 POWER OFF STATUS

■ Operating description

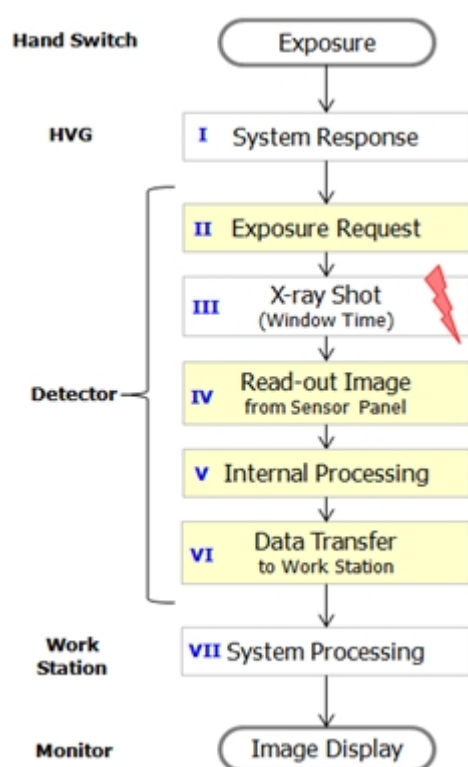

Figure 21: X-ray exposure & image acquisition

Item		min.	typ.	max.	unit	
Exposure request time (II) Before x-ray pulse start		-	-	0.5	sec	
Exposure window		-	0.5	4.0	sec	
Image transmitted after exposure done (IV + V + VI)	Wireless	S4335-AW	3.5	4.0	-	sec
		S4343-AW SZ4343-W	4.2	4.7		
	Wired	S4335-AW	-	2.05	2.50	sec
		S4343-AW SZ4343-W		2.35	2.80	
Image cycle time for exposure of 0.5sec		8	-	-	sec	
Booting time		-	24	40	sec	

Table 9 OPERATING TIME TABLE

5. SPECIFICATION

		S4335-AW	S4335-AWV	S4343-AW / SZ4343-W
Detector Type		Cesium Iodide scintillator (CsI)	Gadolinium Oxy-sulfide (Gd ₂ O ₂ S:Tb)	Cesium Iodide scintillator(CsI)
		Indirect		Indirect
Effective Pixel Matrix		3, 040 x 2, 466 pixels		3, 040 x 3, 036 pixels
Effective Pixel Area		425.6 x 345.24 mm		425.60 x 425.04 mm
Pixel Pitch		140 μm		140 μm
Detector Dimensions (W x L x H)		460 x 384 x 15 mm		460 x 460 x 15 mm
Detector Weight		Approx. 3 kg	Approx. 2.8 kg	Approx. 3.6 kg
Battery	Nominal Capacity	Typ. 3,200mAh		Typ. 3,200mAh
	Nominal Voltage	11.55V		11.55V
Operation Environment		Temperature: 10 – 35 °C Humidity: 20 – 75 % Pressure: 70 – 106 kPa		Temperature: 10 – 35 °C Humidity: 20 – 75 % Pressure: 70 – 106 kPa
Storage and Transportation Environment		Temperature: -15 – 55°C Humidity: 10 – 95 % Pressure: 50 – 106 kPa		Temperature: -15 – 55°C Humidity: 10 – 95 % Pressure: 50 – 106 kPa
International Protection		IP54		IP54

6. APPENDICES

FCC Statement of Conformance

Federal Communication Commission Interference Statement

This equipment has been tested and found to comply with the limits for a Class A digital device, pursuant to part 15 of the FCC Rules. These limits are designed to provide reasonable protection against harmful interference when the equipment is operated in a commercial environment. This equipment generates, uses, and can radiate radio frequency energy and, if not installed and used in accordance with the instruction manual, may cause harmful interference to radio communications. Operation of this equipment in a residential area is likely to cause harmful interference in which case the user will be required to correct the interference at his own expense.

This device complies with Part 15 of the FCC Rules. Operation is subject to the following two conditions: (1) This device may not cause harmful interference, and (2) this device must accept any interference received, including interference that may cause undesired operation.

FCC Caution: Any changes or modifications not expressly approved by the party responsible for compliance could void the user's authority to operate this equipment.

This device and its antenna(s) must not be co-located or operation in conjunction with any other antenna or transmitter.

IMPORTANT NOTE:

FCC Radiation Exposure Statement:

This equipment complies with FCC radiation exposure limits set forth for an uncontrolled environment.

This equipment should be installed and operated with minimum distance 0mm between the radiator & your body.

IC Statement

This Class A digital apparatus complies with Canadian ICES-003.

This device complies with Industry Canada license-exempt RSS standard(s).

Operation is subject to the following two conditions: (1) this device may not cause interference, and (2) this device must accept any interference, including interference that may cause undesired operation of the device.

Cet appareil numérique de la classe A est conforme à la norme NMB-003 du Canada.

Le présent appareil est conforme aux CNR d'Industrie Canada applicables aux appareils

radio exempts de licence. L'exploitation est autorisée aux deux conditions suivantes : (1)

l'appareil ne doit pas produire de brouillage, et (2) l'utilisateur de l'appareil doit accepter tout brouillage radioélectrique subi, même si le brouillage est susceptible d'en compromettre le fonctionnement.

Any changes or modifications not expressly approved by the manufacturer could void the user's authority to operate this equipment.

This device and its antenna(s) must not be co-located or operation in conjunction with any other antenna or transmitter.

This radio transmitter (identify the device by certification number or model number if Category II) has been approved by Industry Canada to operate with the antenna types listed below with the maximum permissible gain indicated. Antenna types not included in this list, having a gain greater than the maximum gain indicated for that type, are strictly prohibited for use with this device.

The device could automatically discontinue transmission in case of absence of information to transmit, or operational failure. Note that this is not intended to prohibit transmission of control or signaling information or the use of repetitive codes where required by the technology.

The maximum antenna gain permitted (for devices in the bands 5250-5350 MHz and 5470-5725 MHz) to comply with the e.i.r.p. limit.

The maximum antenna gain permitted (for devices in the band 5725-5825 MHz) to comply with the e.i.r.p. limits specified for point-to-point and non point-to-point operation as appropriate,

High-power radars are allocated as primary users (meaning they have priority) of the bands 5250-5350 MHz and 5650-5850 MHz and these radars could cause interference and/or damage to LE-LAN devices.

Devices subject to this section shall not be capable of transmitting in the band 5600-5650 MHz in Canada.

IMPORTANT NOTE:

IC Radiation Exposure Statement

This equipment complies with IC RSS-102 radiation exposure limits set forth for an uncontrolled environment. This equipment should be installed and operated with minimum distance 0mm between the radiator & your body.

Cet équipement est conforme aux limites d'exposition aux rayonnements IC établies pour un environnement non contrôlé. Cet équipement doit être installé et utilisé avec un minimum de 0mm de distance entre la source de rayonnement et votre corps.

Transmit Antenna Notice

This radio transmitter [IC: 649E-WBW880A] has been approved by Innovation, Science and Economic Development Canada to operate with the antenna types listed below, with the maximum permissible gain indicated. Antenna types not included in this list that have a gain greater than the maximum gain indicated for any type listed are strictly prohibited for use with this device.

Antenna list (type, maximum gain(dBi))

Model	Type	Frequency Range(MHz)	Maximum gain (dBi)
WIFI_SAMSUNG_005	Patch ant	2412~2472	2.9
		5180-5240	7.3
		5260-5320	7.3
		5500-5720	4.9
		5745-5825	4.9
WIFI_SAMSUNG_006	Patch ant	2412~2472	2.0
		5180-5240	3.9
		5260-5320	4.2
		5500-5720	3.0
		5745-5825	4.3

Tests for EMC and RF including wireless EMC were performed according to the standards in the following table below.

Item	Standards
EMC	IEC 60601-1-2
Wireless EMC	EN 301 489-1
	EN 301 489-17
RF	47 CFR Part 15C
	47 CFR Part 15E
	EN 300 328
	EN 301 893

EMC Declaration

1. Compliance Statement

This equipment complies with IEC 60601-1-2 EMC standards for medical devices.

This equipment needs special precautions regarding EMC and needs to be installed and put into service according to the EMC information provided in the user manual.

Do not use any wireless devices, including cellular phones, near the system. All wireless devices, whether they comply with the EMC standard or not, may emit electromagnetic interferences and cause the system to malfunction when they are used nearby.

This equipment should not be used adjacent to or stacked with other equipment; if adjacent or stacked use is necessary, the equipment should be tested and verified in order to ensure normal operations in the configuration in which it will be used.

Changes or modifications not expressly approved by the party responsible for compliance could void the user's authority to operate the equipment.

All interconnect cables to peripheral devices must be shielded and properly grounded, except when technologically prohibited. Use of cables not properly shielded and grounded may result in the equipment causing radio frequency interference.

EMC Cable List

Port No.	Name	Type*	Cable Max. > 3 m	Cable Shielded	Comments
Signal					
1	Tether cable	I/O	7.0	Shielded	None
*Note: I/O = Signal Input or Output Port (Not Involved in Process Control)					

The use of cables or accessories other than those specified may result in increased emissions or decreased immunity.

Should any interference (EMC) be detected with other equipment, please position other equipment away from this one.

When using this system on a patient with an implantable pacemaker or an implantable cardioverter defibrillator, the patient must be informed that continuous X-ray exposure in pulse form may cause the pacemaker or cardioverter defibrillator to malfunction.

When using this system, ensure that X-rays are not exposed directly onto the patient's implantable pacemaker or implantable cardioverter defibrillator, and that the exposure time is kept as short as possible.

This equipment may be interfered with by other equipment, even if that other equipment complies with CISPR EMISSION requirements.



Restriction of use of Wi-Fi using 5 GHz bands(5150 - 5350 MHz) "In the EU, the Wi-Fi function in this equipment should not be used outdoors.

≡ Wired & Wireless Interface

Wired	Standard	IEEE 802.3 compliant
	Physical data rate	10/100/1000 BASE-T
Wireless	Standard	IEEE 802.11 a/b/g/n/ac WI-FI
	Frequency	2.4GHz/5GHz dual
	Modulation	OFDM with BPSK, QPSK, 16 QAM, 64 QAM, DBPSK, CCK
	Security	Open, WEP, WPA/WPA2 PSK, PWA/WPA2 Enterprise
	Physical data rate	<ul style="list-style-type: none">•IEEE 802.11a : 6-54Mbps•IEEE 802.11b : 1-11Mbps•IEEE 802.11g : 6-54Mbps•IEEE 802.11n : 6.5-300Mbps
Power Output (EIRP)	For 2.4 GHz band : 13.80 dBm For 5 GHz Lower sub-band : 14.76 dBm For 5 GHz Higher sub-band : 12.39 dBm	

Table1

Guidance and manufacturer's declaration- Electromagnetic emissions		
This Wireless Detector is intended for use in the electromagnetic environment specified below. The user of this Wireless Detector should assure that it is used in such an environment		
Emission test	Compliance	Electromagnetic environment - guidance
RF emissions CISPR 11	Group 1	This Wireless Detector uses RF energy only for its internal function. Therefore, its RF emissions are very low and are not likely to cause any interference in nearby electronic equipment.
RF emissions CISPR 11	Class A	This Wireless Detector is suitable for use in all establishments other than domestic, and may be used in domestic establishments and those directly connected to the public low-voltage power supply network that supplies buildings used for domestic purposes, provided the following warning is heeded:
Harmonics emission IEC 61000-3-2	Class A	
Voltage fluctuations/ flicker emissions IEC 61000-3-3	Complies	Warning: This equipment/system is intended for use by healthcare professionals only. This equipment/system may cause radio interference or may disrupt the operation of nearby equipment. It may be necessary to take mitigation measures, such as re-orienting or relocating the Wireless Detector or shielding the location.

Table2

Guidance and manufacturer's declaration- Electromagnetic immunity			
This Wireless Detector is intended for use in the electromagnetic environment specified below. The customer or the user of this Wireless Detector should assure that it is used in such an environment.			
IMMUNITY test	IEC 60601 test level	Compliance level	Electromagnetic environment – guidance
Electrostatic discharge (ESD) IEC61000-4-2	±6 kV Contact ±8 kV Air	±6 kV Contact ±8 kV Air	Floors should be wood, concrete or ceramic tile. If floors are covered with synthetic material, the relative humidity should be at least 30 %
Electrical fast Transient / burst IEC61000-4-4	±2kV for power supply lines ±1kV for input/output lines	±2kV for power supply lines ±1kV for input/output lines	Mains power quality should be that of a typical commercial or hospital environment.
Surge IEC61000-4-5	±1 kV differential mode ±2 kV common mode	±1 kV differential mode ±2 kV common mode	Mains power quality should be that of a typical commercial or hospital environment.
Power frequency (50/60Hz) Magnetic field IEC61000-4-8	3.0 A/m	3.0 A/m	Power frequency magnetic fields should be at levels characteristic of a typical location in a typical commercial or hospital environment.
Voltage dips, short Interruptions and Voltage variations on power supply input lines IEC61000-4-11	<5% U _T (>95% dip in U _T) for 0.5cycle 40% U _T (60% dip in U _T) for 5 cycle, 6 cycle 70% U _T (30% dip in U _T) for 25 cycle, 30 cycle <5% U _T (>95% dip in U _T) for 5 sec	<5% U _T (>95% dip in U _T) for 0.5cycle 40% U _T (60% dip in U _T) for 5 cycle, 6 cycle 70% U _T (30% dip in U _T) for 25 cycle, 30 cycle <5% U _T (>95% dip in U _T) for 5 sec	Mains power quality should be that of a typical commercial or hospital environment. If the user of this Wireless Detector requires continued operation during power mains interruptions, it is recommended that this Wireless Detector be powered from an uninterruptible power supply or a battery
Note: U _T is the a.c. mains voltage prior to application of the test level.			

Table3

Guidance and manufacturer's declaration- Electromagnetic immunity			
This Wireless Detector is intended for use in the electromagnetic environment specified below. The customer or the user of this Wireless Detector should assure that it is used in such an environment.			
IMMUNITY test	IEC 60601 TEST LEVEL	Compliance level	Electromagnetic environment – guidance
<p>Conducted RF IEC 61000-4-6</p> <p>Radiated RF IEC 61000-4-3</p>	<p>3 Vrms 150 kHz to 80 MHz</p> <p>3 V/m 80 MHz to 2,5 GHz</p>	<p>3 Vrms 150 kHz to 80 MHz</p> <p>3 V/m 80 MHz to 2,5 GHz</p>	<p>Portable and mobile RF communications equipment should be used no closer to any part of this Wireless Detector, including cables, than the recommended separation distance calculated from the equation applicable to the frequency of the transmitter.</p> <p>Recommended separation distance</p> <p>$d = \left[\frac{3.5}{V_1}\right]\sqrt{P}$</p> <p>$d = \left[\frac{3.5}{E_1}\right]\sqrt{P}$ 80 MHz to 800 MHz</p> <p>$d = \left[\frac{7}{E_1}\right]\sqrt{P}$ 800 MHz to 2,5 GHz</p> <p>where P is the maximum output power rating of the transmitter in watts (W) according to the transmitter manufacturer and d is the recommended separation distance in metres (m).</p> <p>Field strengths from fixed RF transmitters, as determined by an electromagnetic site survey,^a should be less than the compliance level in each frequency range.^b</p> <p>Interference may occur in the vicinity of equipment marked with the following symbol:</p> 
NOTE 1 At 80 MHz and 800 MHz, the higher frequency range applies.			
NOTE 2 These guidelines may not apply in all situations. Electromagnetic propagation is affected by absorption and reflection from structures, objects and people.			
<p>^a Field strengths from fixed transmitters, such as base stations for radio (cellular/cordless) telephones and land mobile radios, amateur radio, AM and FM radio broadcast and TV broadcast cannot be predicted theoretically with accuracy. To assess the electromagnetic environment due to fixed RF transmitters, an electromagnetic site survey should be considered. If the measured field strength in the location in which this Wireless Detector is used exceeds the applicable RF compliance level above, this Wireless Detector should be observed to verify normal operation. If abnormal performance is observed, additional measures may be necessary, such as re-orienting or relocating this Wireless Detector.</p> <p>^b Over the frequency range 150 kHz to 80 MHz, field strengths should be less than 3 V/m.</p>			

Table4

Recommended separation distances between portable and mobile RF communications equipment and this Wireless Detector			
This Wireless Detector is intended for use in an electromagnetic environment in which radiated RF disturbances are controlled. The customer or the user of this Wireless Detector can help prevent electromagnetic interference by maintaining a minimum distance between portable and mobile RF communications equipment (transmitters) and this Wireless Detector as recommended below, according to the maximum output power of the communications equipment.			
Rated maximum output power of transmitter W	Separation distance according to frequency of transmitter m		
	150 kHz to 80 MHz $d = \left[\frac{3.5}{V-1}\right]\sqrt{P}$	80 MHz to 800 MHz $d = \left[\frac{3.5}{E-1}\right]\sqrt{P}$	800 MHz to 2.5 GHz $d = \left[\frac{7}{E-1}\right]\sqrt{P}$
0.01	0.12	0.12	0.24
0.1	0.37	0.37	0.74
1	1.17	1.17	2.34
10	3.69	3.69	7.38
100	11.67	11.67	23.34
For transmitters rated at a maximum output power not listed above, the recommended separation distance <i>d</i> in metres (m) can be estimated using the equation applicable to the frequency of the transmitter, where <i>P</i> is the maximum output power rating of the transmitter in watts (W) according to the transmitter manufacturer.			
NOTE 1 At 80 MHz and 800 MHz, the separation distance for the higher frequency range applies.			
NOTE 2 These guidelines may not apply in all situations. Electromagnetic propagation is affected by absorption and reflection from structures, objects and people.			

RF exposure compliance

The available scientific evidence does not show that any health problems are associated with using low power wireless devices. There is no proof, however, that these low power wireless devices are absolutely safe. Low power wireless devices emit low levels radio frequency energy (RF) in the microwave range while being used. Whereas high levels of RF can produce health effects (by heating tissue), exposure of low-level RF that does not produce heating effects causes no known adverse health effects. Many studies of low-level RF exposures have not found any biological effects. Some studies have suggested that some biological effects might occur, but such findings have not been confirmed by additional research. This device has been tested and found to comply with FCC/IC radiation exposure limits set forth for an uncontrolled equipment and meets the FCC radio frequency (RF) Exposure Guidelines in Supplement.