



129 Samsung-ro,  
Yeongtong-gu, Suwon-Si,  
Gyeonggi-Do, 443-742  
Korea  
Tel: 82-31-8062-4278  
Fax: 82-31-279-9985

# FCC TEST REPORT

**Manufacturer: SAMSUNG Electronics Co., Ltd.**

**Model: SC-02G**

**FCC ID: A3LSWDSC02G**

**Application Type: Certification**

**EUT Type: Portable Handset**

All measurements reported here are in accordance with FCC Rules,  
47CFR Part2, Part22, and Part24.

  
Prepared By ..... Date ..... 2014.09.12  
Jooha BEK  
Test Engineer

  
Checked By ..... Date ..... 2014.09.12  
YG Choi  
Deputy Technical Manager

  
Authorized By ..... Date ..... 2014.09.12  
WT Jang  
Technical Manager



## Table of Contents

<b>§2.1033 General Information .....</b>	<b>3</b>
<b>1. INTRODUCTION .....</b>	<b>4</b>
1.1. General.....	4
<b>2. PRODUCT INFORMATION .....</b>	<b>4</b>
2.1. Equipment Description .....	4
2.2. Device Capabilities .....	4
2.3. Test Configuration.....	4
2.4. EMI Suppression Device(s)/Modifications .....	4
<b>3. DESCRIPTION OF TESTS .....</b>	<b>5</b>
3.1. Evaluation Procedure.....	5
3.2. Radiated Measurements .....	5
<b>4. TEST EQUIPMENT LIST .....</b>	<b>6</b>
<b>5. SAMPLE CALCULATIONS .....</b>	<b>7</b>
<b>6. DESCRIPTION OF TESTS .....</b>	<b>8</b>
6.1. Summary .....	8
6.2. Occupied Bandwidth .....	9
6.3. Spurious and Harmonic Emissions at Antenna Terminal.....	13
6.4. Band Edge Emissions at Antenna Terminal .....	27
6.5. Peak-Average Ratio(GSM/EDGE).....	35
6.6. Frequency Stability / Temperature Variation .....	37
6.7. Radiated Power (ERP/EIRP).....	41
6.8. Radiated Spurious Emissions Measurements .....	44
<b>7. CONCLUSION.....</b>	<b>50</b>



Issue Date:

**§2.1033 General Information**

**APPLICANT:** Samsung Electronics Co., Ltd.

**APPLICANT ADDRESS:** 129 Samsung-ro,  
Yeongtong-gu, Suwon-si, Gyeonggi-do, 443-742, Korea

**TEST SITE:** Samsung Electronics Co., Ltd.

**TEST SITE ADDRESS:** 129 Samsung-ro,  
Yeongtong-gu, Suwon-si, Gyeonggi-do, 443-742, Korea

**FCC RULE PART(S):** §2, §22(H), §24(E),

**TEST PROCEDURE(S):** ANSI/TIA603-C-2004, KDB971168 v02r01

**BASE MODEL:** SC-02G

**FCC ID:** A3LSWDSC02G

**FCC CLASSIFICATION:** PCS Licensed Transmitter Held to Ear (PCE)

**MODE:** GSM / EDGE / WCDMA

**EMISSION DESIGNATOR:** 247KGXW (GSM850), 244KG7W (EDGE850)  
246KGXW (GSM1900), 247KG7W (EDGE1900)  
4M17F9W (WCDMA850)

**TX FREQUENCY RANGE** 824.2 – 848.8MHz (GSM850, EDGE850)  
1850.2 – 1909.8MHz (GSM1900, EDGE1900)  
826.4 – 846.6MHz (WCDMA850)

**RX FREQUENCY RANGE** 869.2 – 893.8MHz (GSM850, EDGE850)  
1930.2 – 1989.8MHz (GSM1900, EDGE1900)  
871.4 – 891.6MHz (WCDMA850)

**MAX POWER RATING:** 0.848 W ERP GSM850 (29.28 dBm)  
0.202 W ERP EDGE850 (23.06 dBm)  
1.222 W EIRP GSM1900 (30.87 dBm)  
0.658 W EIRP EDGE1900 (28.18 dBm)  
0.128 W ERP WCDMA850 (21.06 dBm)

**FREQUENCY TOLERANCE:** ±0.00025 % (2.5 ppm)

**TEST DEVICE SERIAL NO.:** FCL-002-A & FCL-002-B

**DATE(S) OF TEST:** July 30 – September 11, 2014



## 1. INTRODUCTION

### 1.1. General

These measurement tests were conducted at SAMSUNG ELECTRONICS CO., LTD. (SUWON). The site address is 129 Samsung-ro, Yeongtong-gu, Suwon-si, Gyeonggi-do, 443-742, Korea.

## 2. PRODUCT INFORMATION

### 2.1. Equipment Description

The Equipment Under Test (EUT) is the Samsung Portable Handset FCC ID: A3LSWDSC02G. The test data contained in this report pertains only to the emissions due to the EUT's 2G/3G licensed transmitters.

### 2.2. Device Capabilities

This device contains the following capabilities:

850/1900 GSM/GPRS/EDGE, 850 WCDMA/HSPA, 802.11a/b/g/n/ac WLAN, Bluetooth (1x, EDR, LE, HS), NFC, ANT+.

### 2.3. Test Configuration

The Samsung Portable Handset FCC ID: A3LSWDSC02G was tested per the guidance of ANSI/TIA-603-C-2004 and KDB 971168 v02r01. See Section 6 of this test report for a description of the radiated and antenna port conducted emissions tests.

### 2.4. EMI Suppression Device(s)/Modifications

No EMI suppression device(s) were added and no modifications were made during testing.



### 3. DESCRIPTION OF TESTS

#### 3.1. Evaluation Procedure

The measurement procedures described in the "Land Mobile FM or PM -Communications Equipment-Measurements and Performance Standards" (ANSI/TIA-603-C-2004) and "Measurement Guidance for Certification of Licensed Digital Transmitters" (KDB 971168 v02r01) were used in the measurement of the Samsung Portable Handset FCC ID: A3LSWDSC02G.

#### 3.2. Radiated Measurements

The radiated and spurious measurements were made Fully-anechoic chamber at a 3-meter test range. The equipment under testing was placed on the rotating device at the same height and at a distance of 3-meters from the receive antenna. The rotating device which can rotate horizontal axis was mounted on the turn unit to facilitate rotation around a vertical axis. The measurement was made for each horizontal/vertical position combination with receive antenna horizontally polarized. This measurement was repeated with receive antenna vertically polarized.

The substitution antenna will replace the EUT antenna at the same position and in vertical polarization. The frequency of the signal generator shall be set to the frequencies that were measured on the EUT. The signal generator, output level, shall be adjusted until an equal or a known related level to what was measured from the EUT is obtained in the spectrum analyzer. This level was recorded. For readings above 1 GHz, the above procedure is repeated using horn antennas and the difference between the gain of the horn and an isotropic antenna are taken into consideration.

The power of the emission is calculated using the following formula:

$$P_{d[\text{dBm}]} = P_{g[\text{dBm}]} - \text{cable loss}_{[\text{dB}]} + \text{antenna gain}_{[\text{dBd,dBi}]}$$

Where  $P_d$  is the dipole equivalent power,  $P_g$  is the generator output into the substitution antenna, and the antenna gain is the gain of the substitute antenna used relative to either a half-wave dipole(dBd) or an isotropic source(dBi). The cable connects the generator to the substitute antenna.

Radiated power levels are investigated with the receive antenna vertically polarized while radiated spurious emissions levels are investigated with the receive antenna horizontally and vertically polarized per ANSI/TIA-603-C-2004.



#### 4. TEST EQUIPMENT LIST

The measuring equipment, which was utilized in performing the tests documented herein, has been calibrated in accordance with the manufacturer's recommendations for utilizing calibration equipment, which is traceable to recognized national standards.

Description	Model	Serial No.	Manufacturer	Cal. Date	Cal. Due
DC Power Supply	E3640A	MY40003594	Agilent	2014-06-18	2015-06-18
DIPOLE ANTENNA	UHA 9105	9105-2412	Schwarzbeck	2013-10-16	2015-10-16
Highpass filter	WHK3.0/18G-10SS	492	Wainwright	2014-04-04	2015-04-04
Highpass filter	WHV1.0/15G-10SS	1	Wainwright	2014-04-04	2015-04-04
HORN Antenna	3115	00143185	ETS LINDGREN	2013-05-15	2015-05-15
Horn Antenna	BBHA 9120	9120D-637	Schwarzbeck	2013-09-05	2015-09-05
HORN Antenna & Pre-amplifier assembly (18GHz to 26.5GHz)	HAP18-26N	216249	Flann	2013-09-24	2015-09-24
Hygrothermograph Data Logger	SK-L200TH2a	005077	SATO	2013-10-29	2014-10-29
Hygrothermograph Data Logger	SK-L200TH2a	005078	SATO	2013-10-29	2014-10-29
Hygrothermograph Data Logger	SK-L200TH2a	005110	SATO	2013-10-29	2014-10-29
LOG PERIODIC DIPOLE ANTENNA	HL040	353255/019	R&S	2013-09-06	2015-09-06
Loop Antenna	HFH2-Z2	100276	R&S	2014-05-19	2016-05-18
Network Analyzer	8753E	JP38160590	HP	2014-06-20	2015-06-20
Power Divider	11636B	58456	Agilent	2014-04-11	2015-04-11
PRE-AMPLIFIER	8449B	3008A00691	Agilent	2013-11-21	2014-11-21
EPM Series Power Meter	E4419B	GB41293846	Agilent	2013-09-17	2014-09-17
POWER SENSOR	E9300H	MY41495838	Agilent	2013-09-17	2014-09-17
Attenuator 10dB	8491B	MY39264180	Agilent	2014-06-17	2015-06-17
PSA Series Spectrum Analyzer	E4440A	MY46187454	Agilent	2014-03-18	2015-03-18
PSG Analog Signal Generator	E8257D	MY51501209	Agilent	2013-11-01	2014-11-01
PXA Signal Analyzer	N9030A	MY52350977	Agilent	2013-10-22	2014-10-22
RF Power Amplifier	5S1G4	304866	AR	2013-12-31	2014-12-31
Temperature Humidity Chamber	SH-241	92000548	Espec	2013-11-11	2014-11-11
Wireless Communications Test Set	E5515C	GB42230535	Agilent	2014-01-07	2015-01-07
Wireless Communications Test Set	E5515C	MY53201087	Agilent	2013-11-05	2014-11-05

Table 4-1 Test Equipment

**Notes:**

None



## 5. SAMPLE CALCULATIONS

### 5.1. GSM Emission Designator

Emission Designator = 250KGXW

GSM BW = 250kHz

G = Phase Modulation

X = Cases not otherwise covered

W = Combination (Audio/Data)

### 5.2. EDGE Emission Designator

Emission Designator = 250KG7W

EDGE BW = 250kHz

G = Phase Modulation

7 = Quantized/Digital Info

W = Combination (Audio/Data)

### 5.3. WCDMA Emission Designator

Emission Designator = 4M16F9W

WCDMA BW = 4.16MHz

F = Frequency Modulation

9 = Composite Digital Info

W = Combination (Audio/Data) (Measured at the 99.75% power bandwidth)

### 5.4. Spurious Radiated Emission

Example: Spurious emission at 3700.40MHz

The receive spectrum analyzer reading at 3 meters with the EUT on the turntable was -81.0dBm. The gain of the substituted antenna is 8.1dBi. The signal generator connected to the substituted antenna terminals is adjusted to produce a reading of -81.0dBm on the spectrum analyzer. The loss of the cable between the signal generator and the terminals of the substituted antenna is 2.0dB at 3700.40MHz. So 6.1dB is added to the signal generator reading of -30.9dBm yielding -24.80dBm. The fundamental EIRP was 25.50dBm so this harmonic was 25.50dBm - (-24.80) = 50.3dBc.



## 6. DESCRIPTION OF TESTS

### 6.1. Summary

FCC Part Section(s)	Test Description	Test Limit	Test Condition	Test Result	Reference
TRANSMITTER MODE (TX)					
2.1049	Occupied Bandwidth	N/A	CONDUCTED	PASS	Section 6.2
2.1051 22.917(a) 24.238(a)	Conducted Band Edge / Spurious Emissions	$> 43 + \log_{10}(P[\text{Watts}])$ at Band Edge and for all out-of-band emissions		PASS	Sections 6.3, 6.4
24.232(d)	Peak-Average Ratio	$< 13$ dB		PASS	Section 6.5
2.1046	Transmitter Conducted Output Power	N/A		PASS	See FCC SAR Report
2.1055 22.355 24.235	Frequency Stability	$< 2.5$ ppm (Part 22) Emission must remain in band (Part 24)		PASS	Section 6.6
22.913(a.2)	Effective Radiated Power	$< 7$ Watts max. ERP	RADIATED	PASS	Section 6.7
24.232(c)	Equivalent Isotropic Radiated Power	$< 2$ Watts max. EIRP		PASS	Section 6.7
2.1053 22.917(a) 24.238(a)	Radiated Spurious Emissions	$> 43 + \log_{10}(P[\text{Watts}])$ for all out-of-band emissions		PASS	Section 6.8

Table 6-1. Summary of Test Results

#### Notes:

1. All modes of operation and data rates were investigated. The test results shown in the following sections represent the worst case emissions.
2. The analyzer plots shown in this section were all taken with a correction table loaded into the analyzer. The correction table was used to account for the losses of the cables and attenuators used as part of the system to connect the EUT to the analyzer at all frequencies of interest.
3. All antenna port conducted emissions testing was performed on a test bench with the antenna port of the EUT connected to the spectrum analyzer through calibrated cables and attenuators.
4. For conducted spurious emissions, automated test software was used to measure emissions and capture the corresponding plots necessary to show compliance. The measurement software utilized is SAMSUNG Electronics "Measurement Automation System", Version 4.1.11.

## 6.2. Occupied Bandwidth §2.1049

### Test Overview

The Occupied bandwidth, that is the frequency bandwidth such that, below its lower and above its upper frequency limits, the mean powers radiated are each equal to 0.5 percent of the total mean power radiated by a given emission shall be measured. All modes of operation were investigated and the worst case configuration results are reported in this section.

### Test Procedure Used

KDB 971168 v02r01 – Section 4.2

### Test Settings

1. The signal analyzer's automatic bandwidth measurement capability was used to perform the 99% Occupied bandwidth and the 26dB bandwidth. The bandwidth measurement was not influenced by any intermediate power nulls in the fundamental emission.
2. RBW = 1~5% of the expected OBW
3. VBW  $\geq 3 \times$  RBW
4. Detector = Peak
5. Trace mode = max hold
6. Sweep = auto couple
7. The trace was allowed to stabilize
8. If necessary, steps 2~7 were repeated after changing the RBW such that it would be within 1~5% of the 99% occupied bandwidth observed in Step 7

### Test Setup

The EUT and measurement equipment were set up as shown in the diagram below.

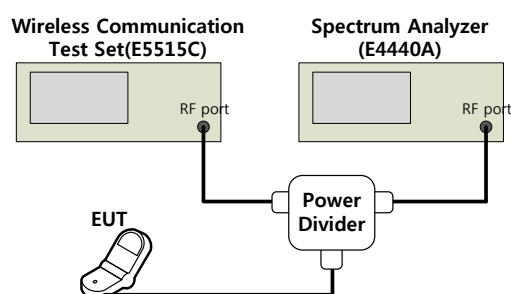
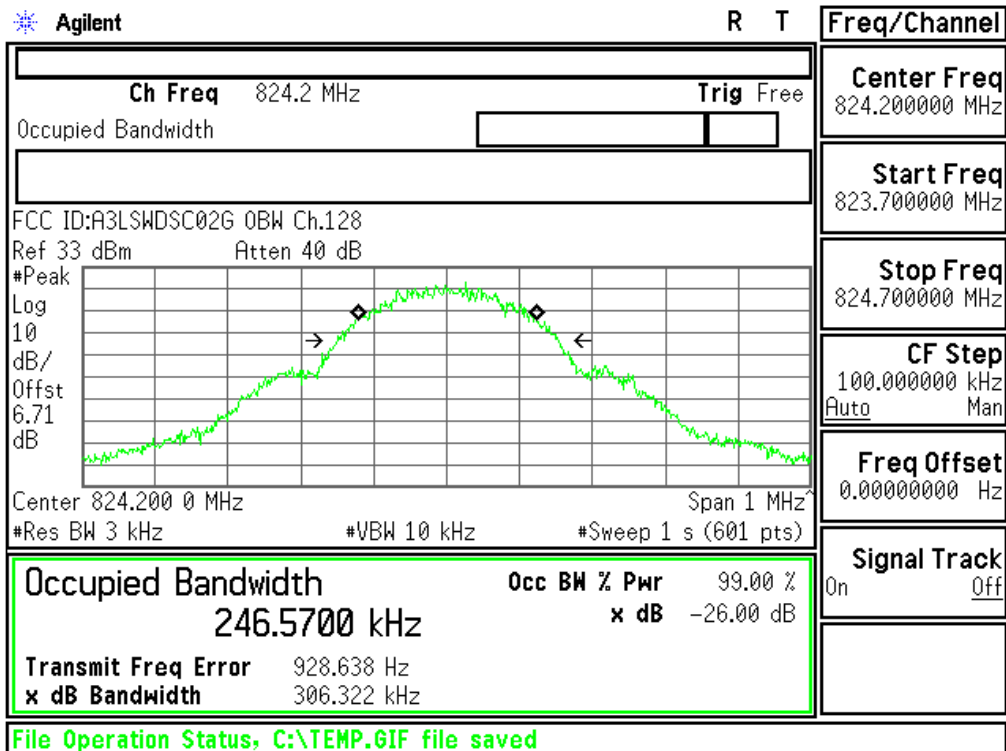

Figure 6-1. Test Instruments & Measurement Setup



Issue Date:

Test Plots



Plot 6-1. Occupied Bandwidth Plot (Cellular GSM Mode - Ch.128)

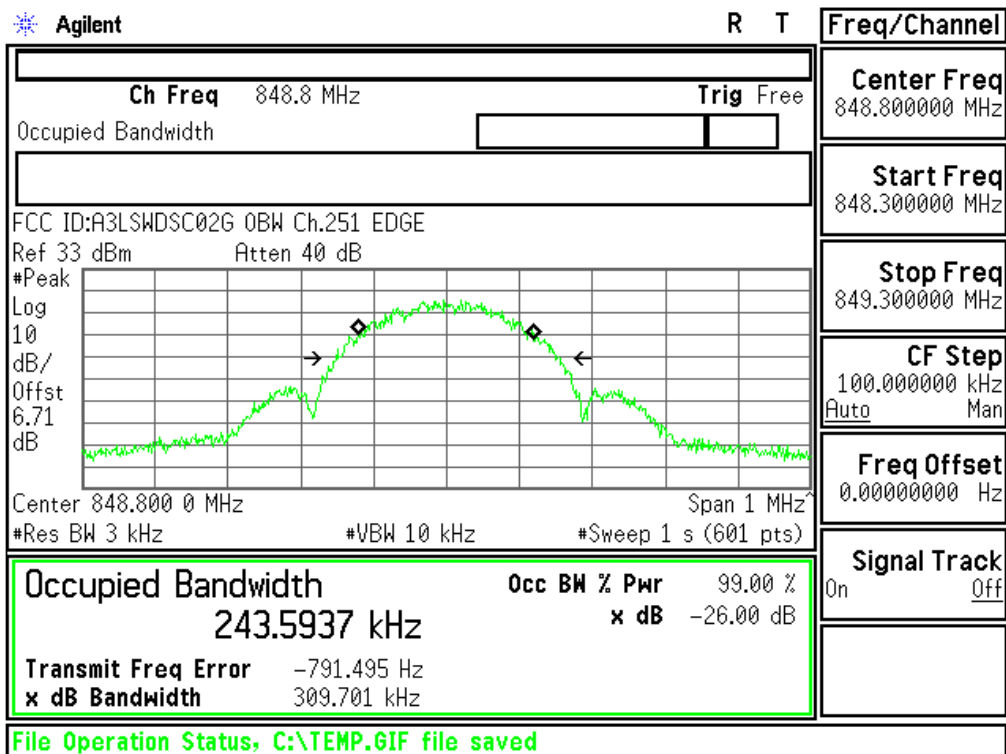

Plot 6-2. Occupied Bandwidth Plot (EDGE850 Mode - Ch.251)



Issue Date:

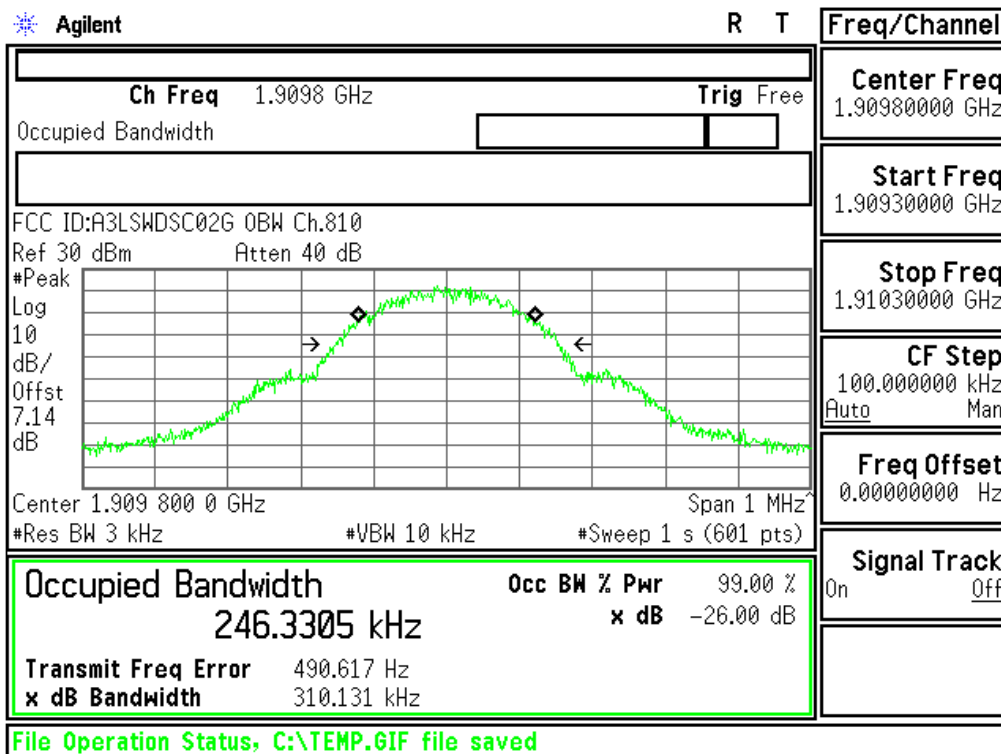

Plot 6-3. Occupied Bandwidth Plot (PCS GSM Mode - Ch.810)

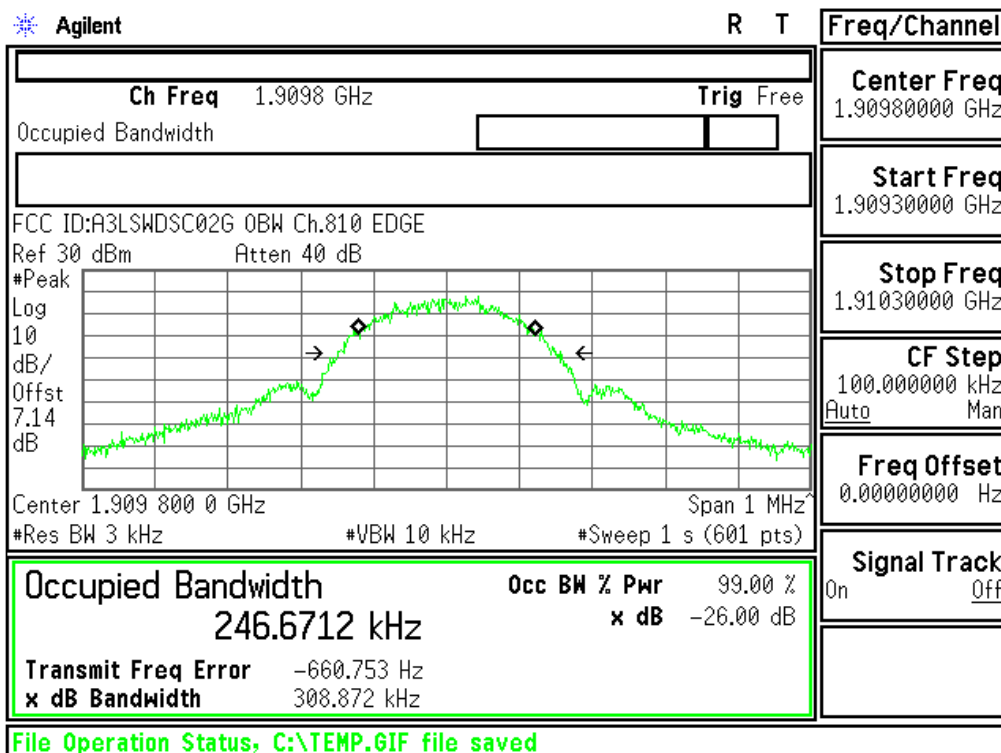

Plot 6-4. Occupied Bandwidth Plot (EDGE1900 Mode - Ch.810)



Issue Date:

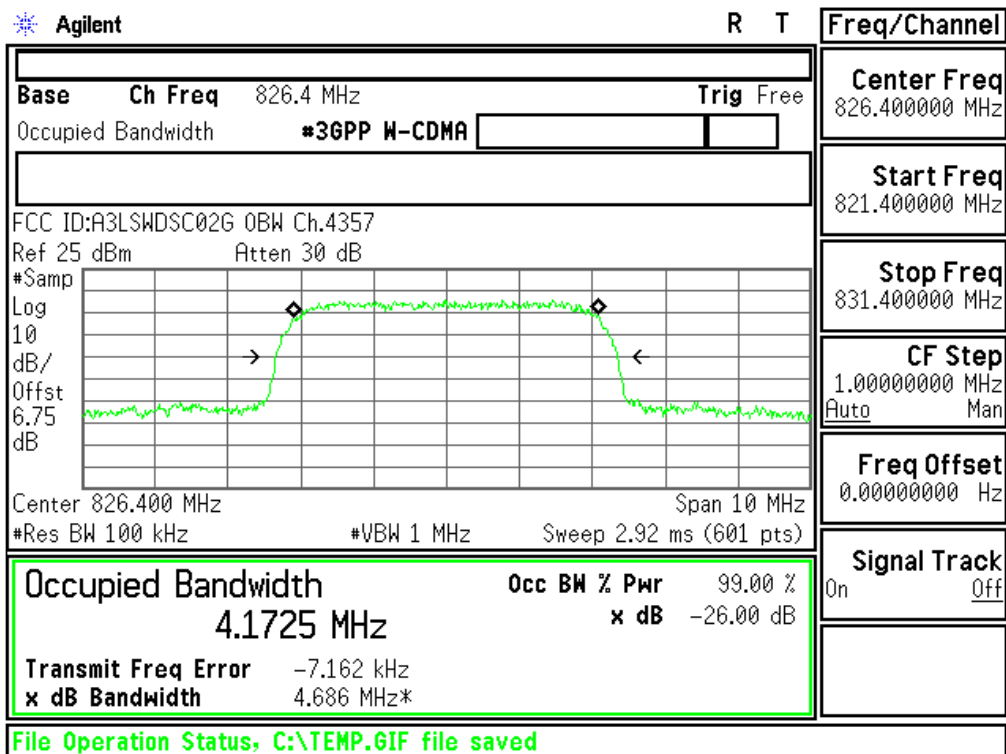

Plot 6-5. Occupied Bandwidth Plot (Cellular WCDMA Mode - Ch.4132(DL4357))



### 6.3. Spurious and Harmonic Emissions at Antenna Terminal §2.1051 §22.917(a) §24.238(a)

#### Test Overview

The level of the carrier and the various conducted spurious and harmonic frequencies is measured by means of a calibrated spectrum analyzer. The spectrum is scanned from the lowest frequency generated in the equipment up to a frequency including its 10th harmonic. All out of band emissions are measured with a spectrum analyzer connected to the antenna terminal of the EUT while the EUT is operating at maximum power, and at the appropriate frequencies. All data rates were investigated to determine the worst case configuration. All modes of operation were investigated and the worst case configuration results are reported in this section.

The minimum permissible attenuation level of any spurious emission is  $43 + \log_{10}(P_{[\text{Watts}]})$ , where P is the transmitter power in Watts. Limit equivalent to -13dBm, calculation shown below.

$$\begin{aligned}43 + 10 \log_{10}(1.567\text{W}) &= 44.95 \text{ dB} \\1.567\text{W} &= 31.95 \text{ dBm} \\31.95 \text{ dBm} - 44.95 \text{ dB} &= -13 \text{ dBm}\end{aligned}$$

#### Test Procedure Used

KDB 971168 v02r01 – Section 6.0

#### Test Settings

1. Start frequency was set to 30MHz and stop frequency was set to 10GHz for Cell, 20GHz for PCS (separated into at least two plots per channel)
2. RBW = 1MHz
3. VBW = 3MHz
4. Detector = Max Peak
5. Trace mode = max hold
6. Sweep time = auto couple
7. The trace was allowed to stabilize

### Test Setup

The EUT and measurement equipment were set up as shown in the diagram below.

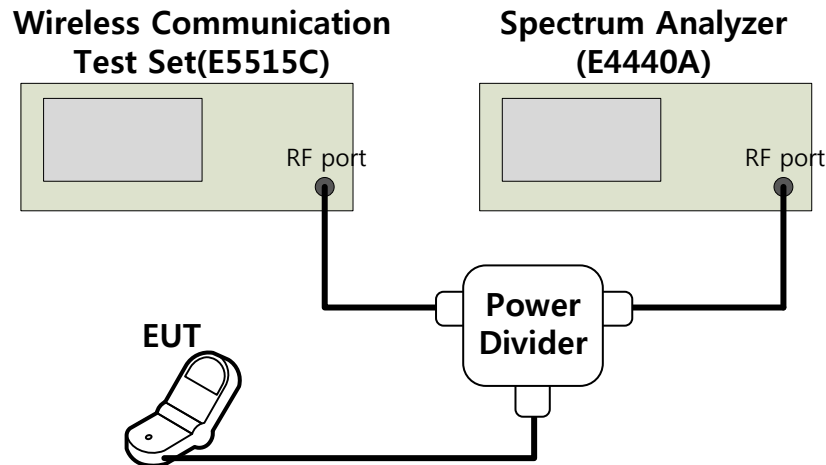

Figure 6-2. Test Instruments & Measurement Setup

### Test Notes

1. Compliance with the applicable limits is based on the use of measurement instrumentation employing a resolution bandwidth of 100 kHz or greater for Part 22 and 1 MHz or greater for Part 24. However, in the 1 MHz bands immediately outside and adjacent to the frequency block a resolution bandwidth of at least one percent of the emission bandwidth of the fundamental emission of the transmitter may be employed. The emission bandwidth is defined as the width of the signal between two points, one below the carrier center frequency and one above the carrier center frequency, outside of which all emissions are attenuated at least 26dB below the transmitter power.
2. The offset which applied to the last plot of each configuration is the worst-case value of the RF path-loss<sup>1</sup> in the frequency range 30MHz to 20GHz.

---

<sup>1</sup> RF path-loss = EUT output – Spectrum Analyzer input



Issue Date:

Test Plots

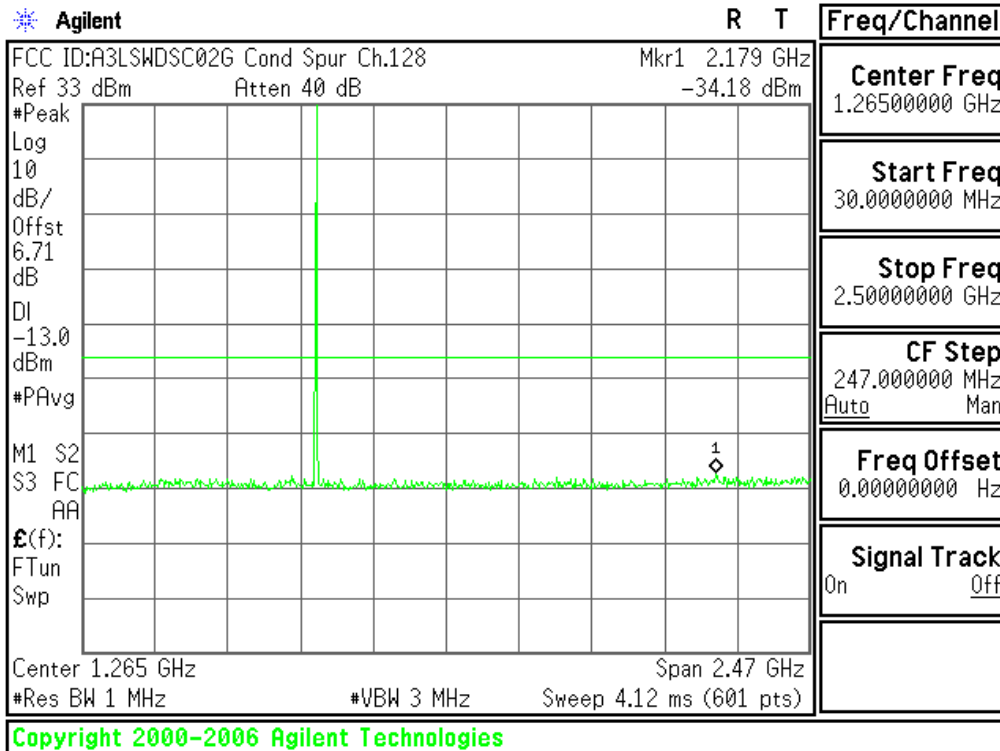

Plot 6-6. Conducted Spurious Plot (Cellular GSM Mode - Ch.128)

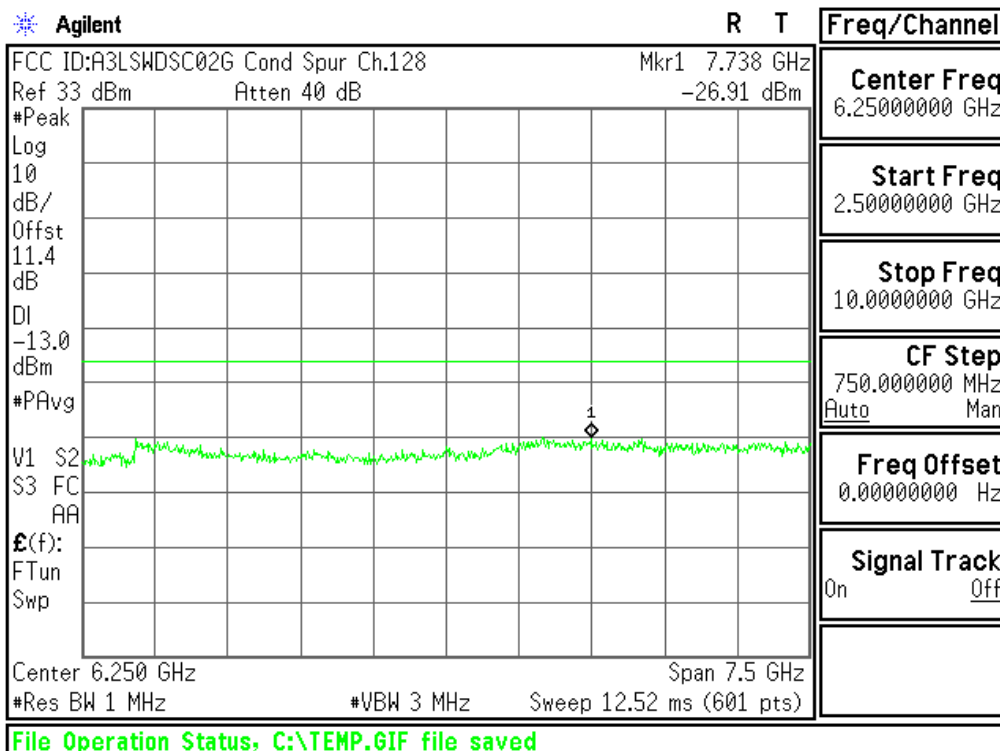

Plot 6-7. Conducted Spurious Plot (Cellular GSM Mode - Ch.128)



Issue Date:

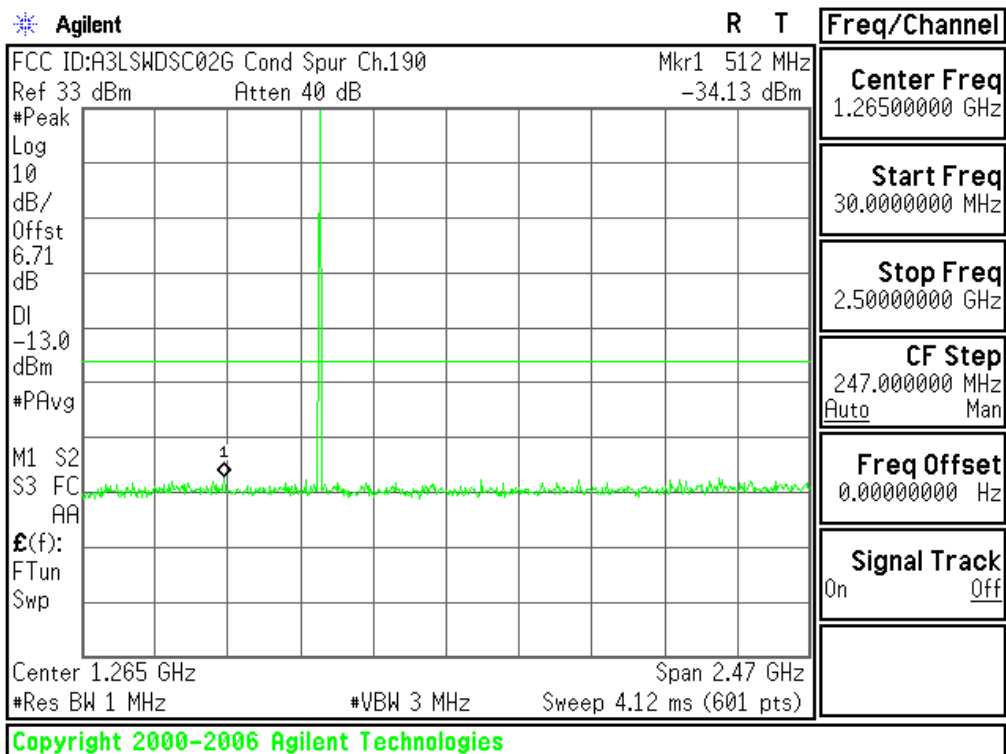

Plot 6-8. Conducted Spurious Plot (Cellular GSM Mode - Ch.190)

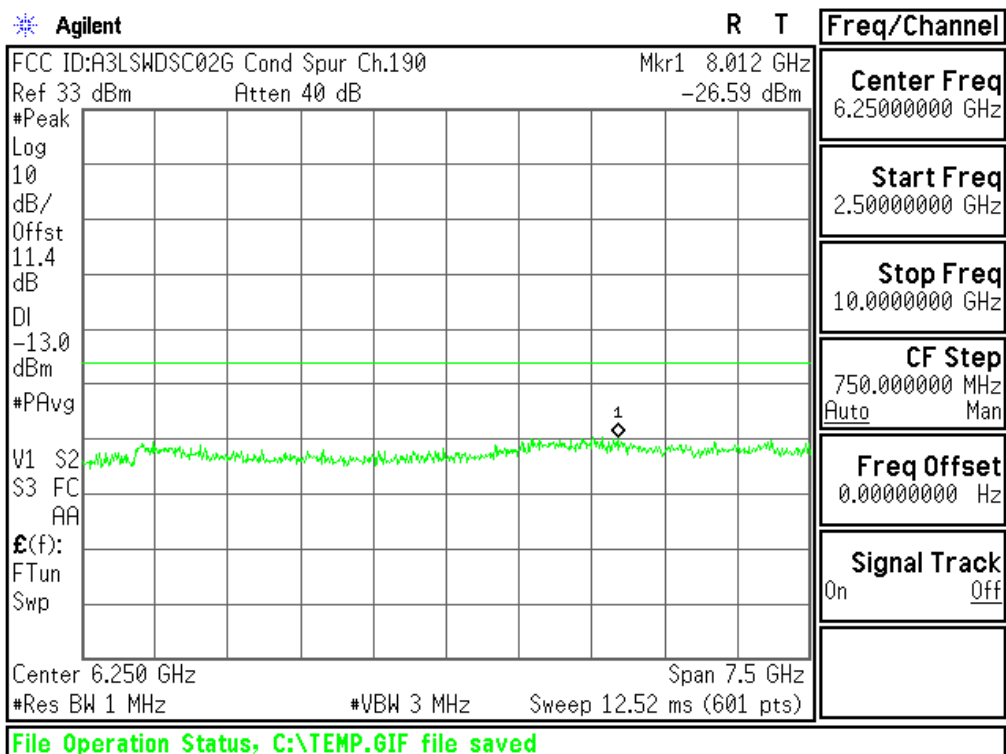

Plot 6-9. Conducted Spurious Plot (Cellular GSM Mode - Ch.190)



Issue Date:

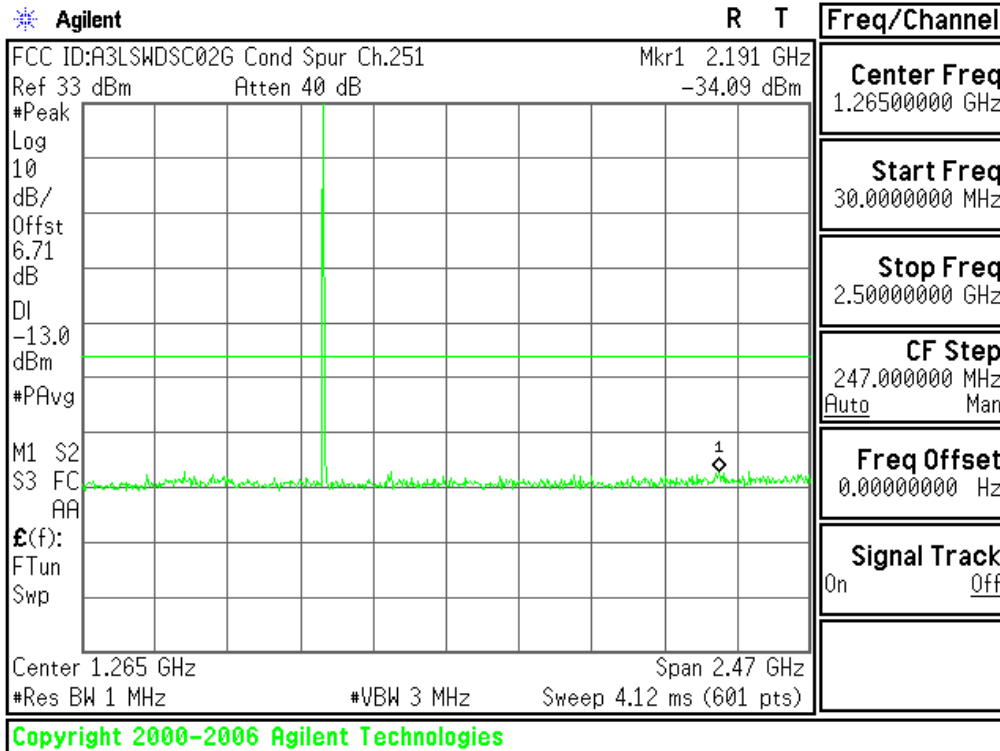

Plot 6-10. Conducted Spurious Plot (Cellular GSM Mode - Ch.251)

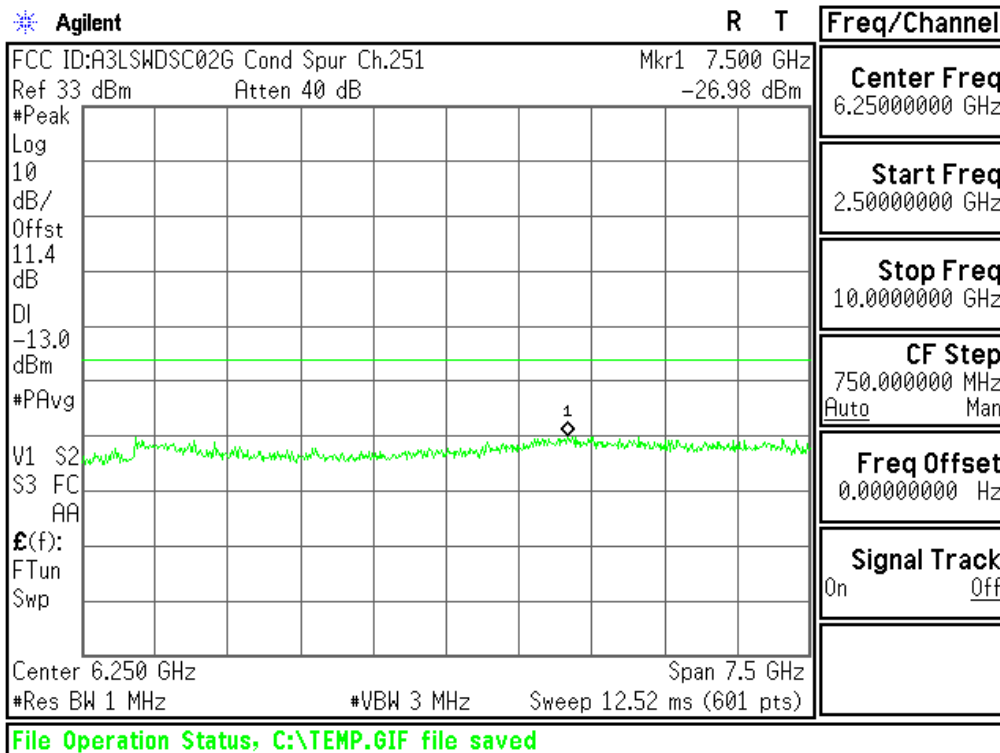

Plot 6-11. Conducted Spurious Plot (Cellular GSM Mode - Ch.251)



Issue Date:

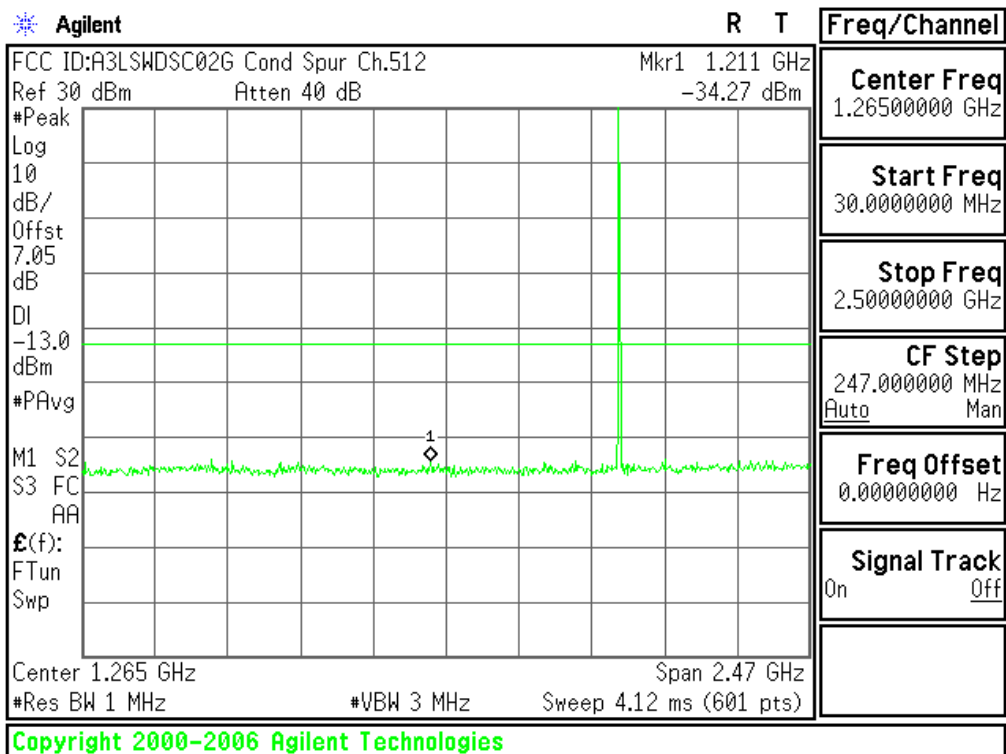

Plot 6-12. Conducted Spurious Plot (PCS GSM Mode - Ch.512)

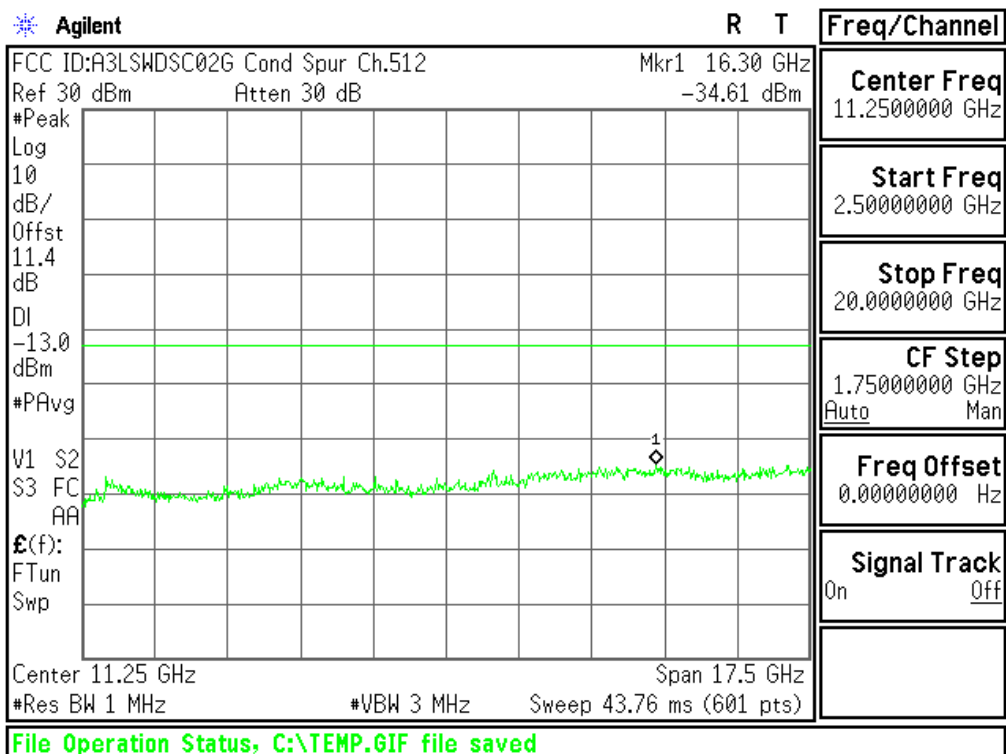

Plot 6-13. Conducted Spurious Plot (PCS GSM Mode - Ch.512)



Issue Date:

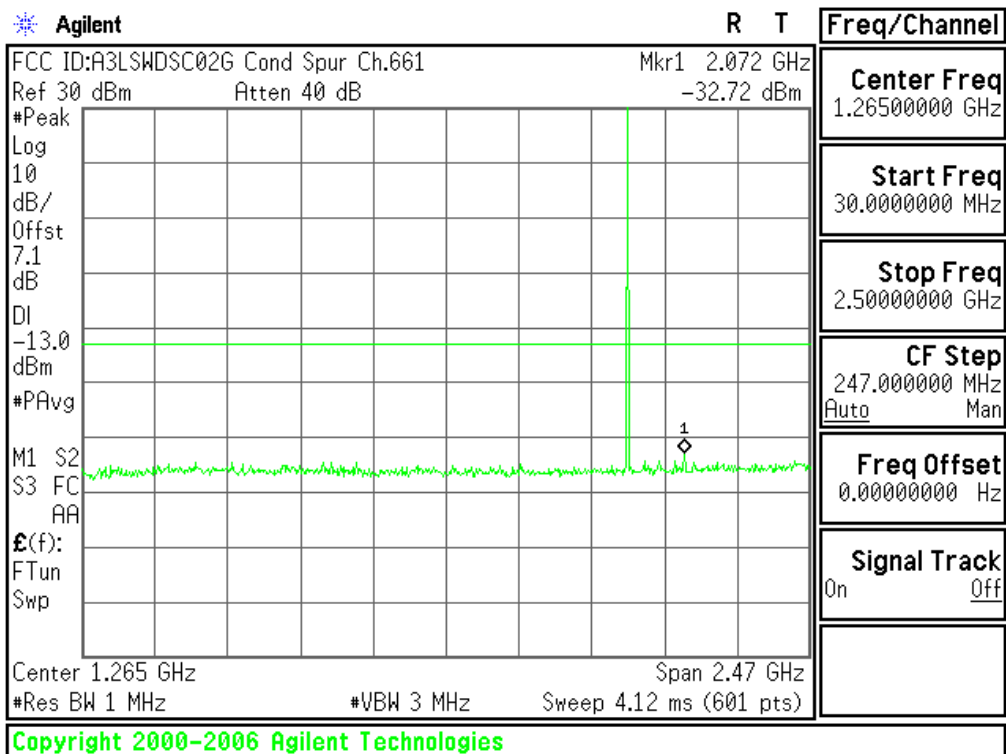

Plot 6-14. Conducted Spurious Plot (PCS GSM Mode - Ch.661)

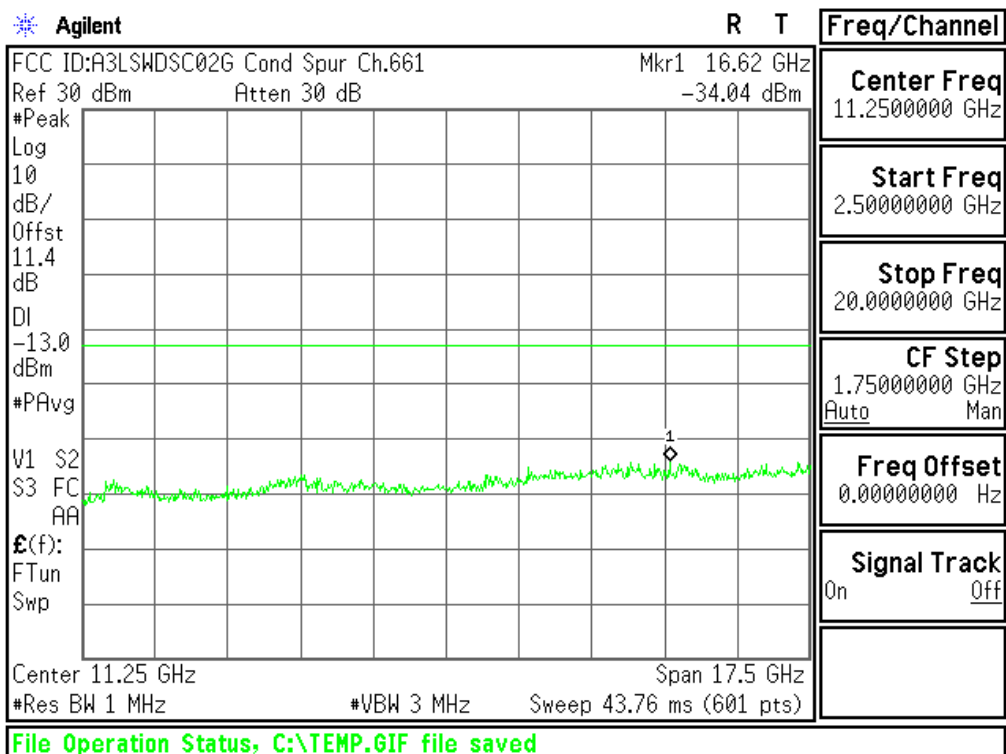

Plot 6-15. Conducted Spurious Plot (PCS GSM Mode - Ch.661)



Issue Date:

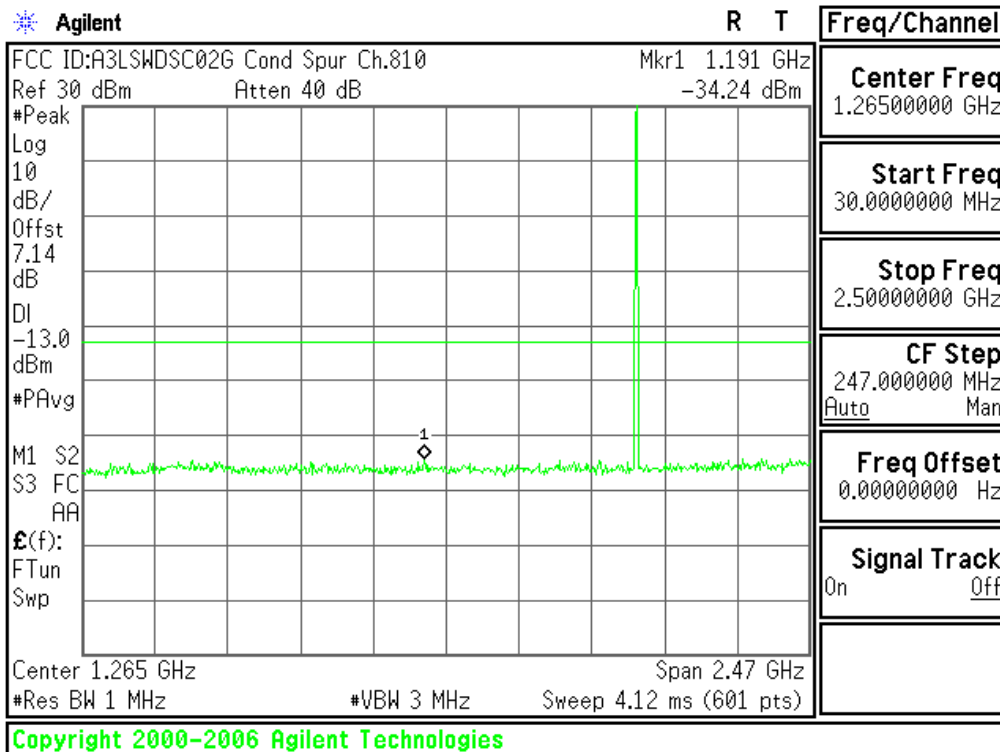

Plot 6-16. Conducted Spurious Plot (PCS GSM Mode - Ch.810)

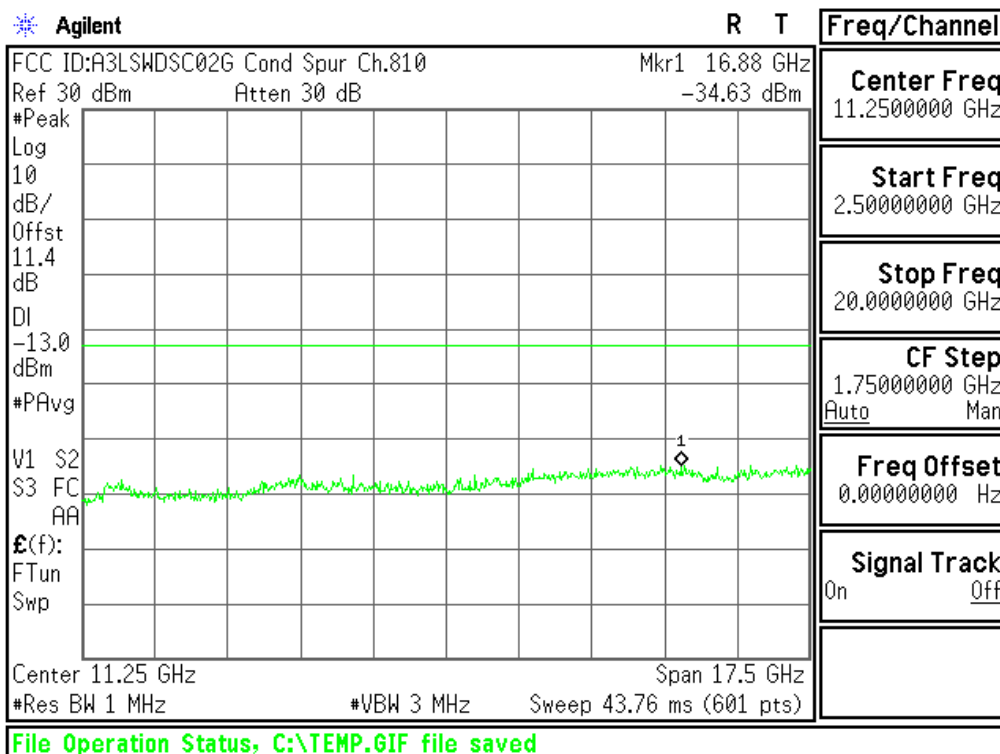

Plot 6-17. Conducted Spurious Plot (PCS GSM Mode - Ch.810)



Issue Date:

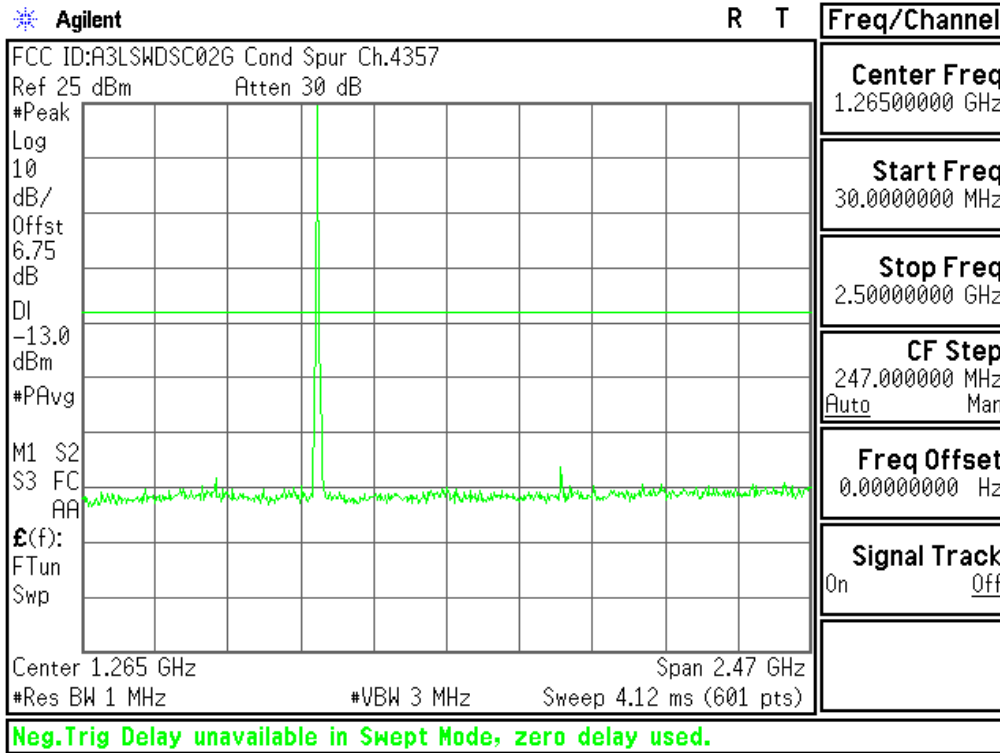

Plot 6-18. Conducted Spurious Plot (Cellular WCDMA Mode - Ch.4132(DL4357))

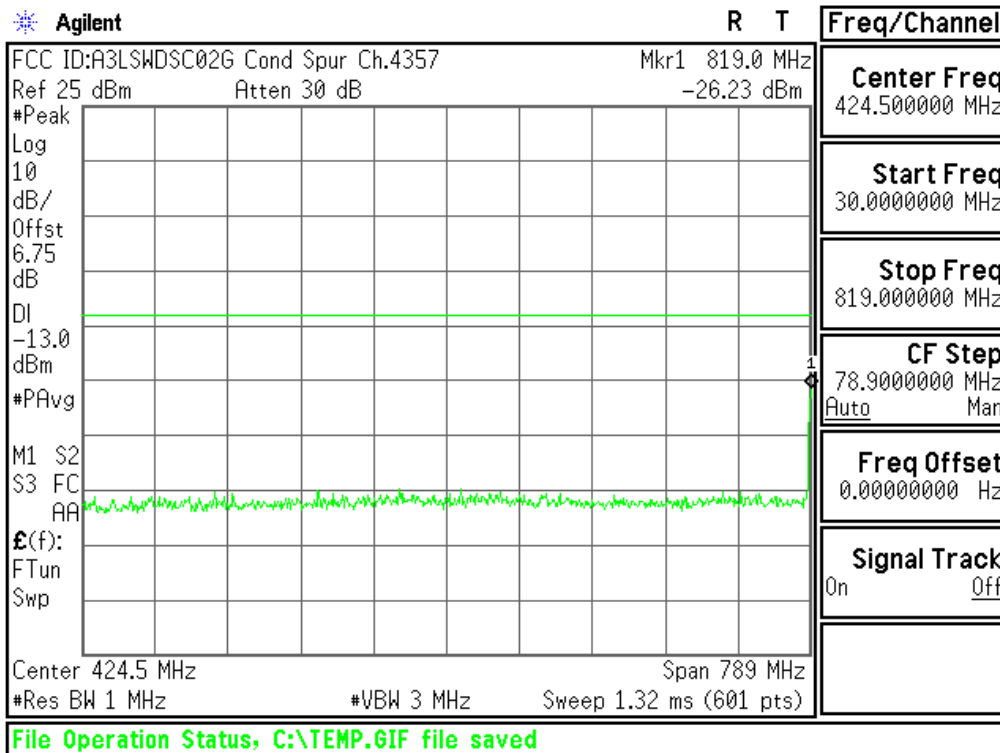

Plot 6-19. Conducted Spurious Plot (Cellular WCDMA Mode - Ch.4132(DL4357))



Issue Date:

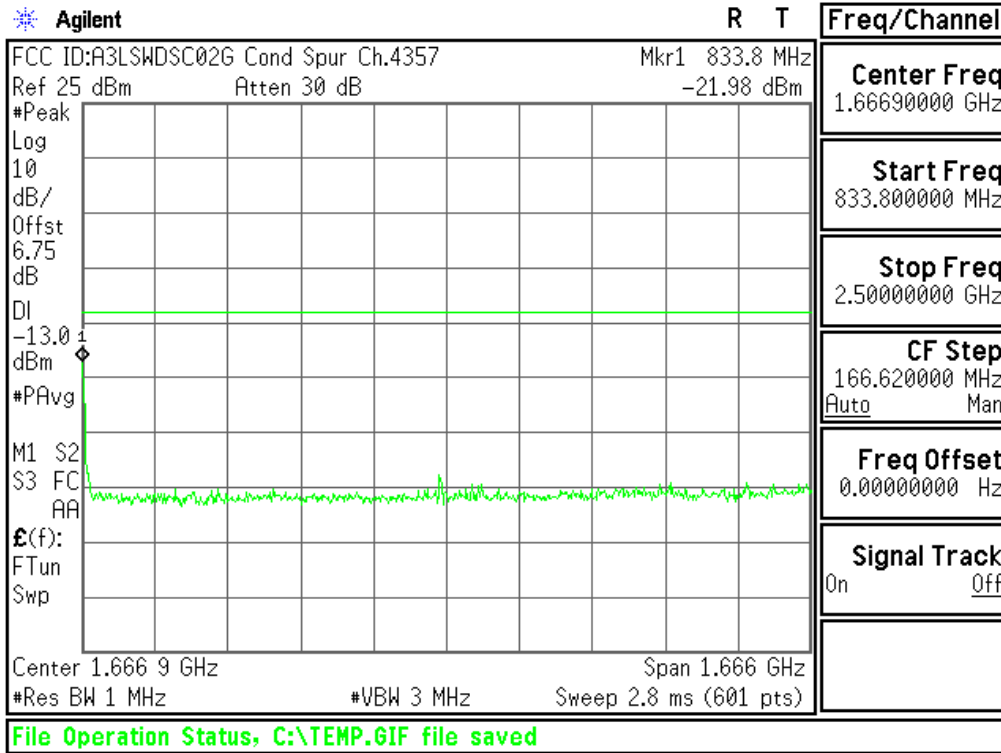

Plot 6-20. Conducted Spurious Plot (Cellular WCDMA Mode - Ch.4132(DL4357))

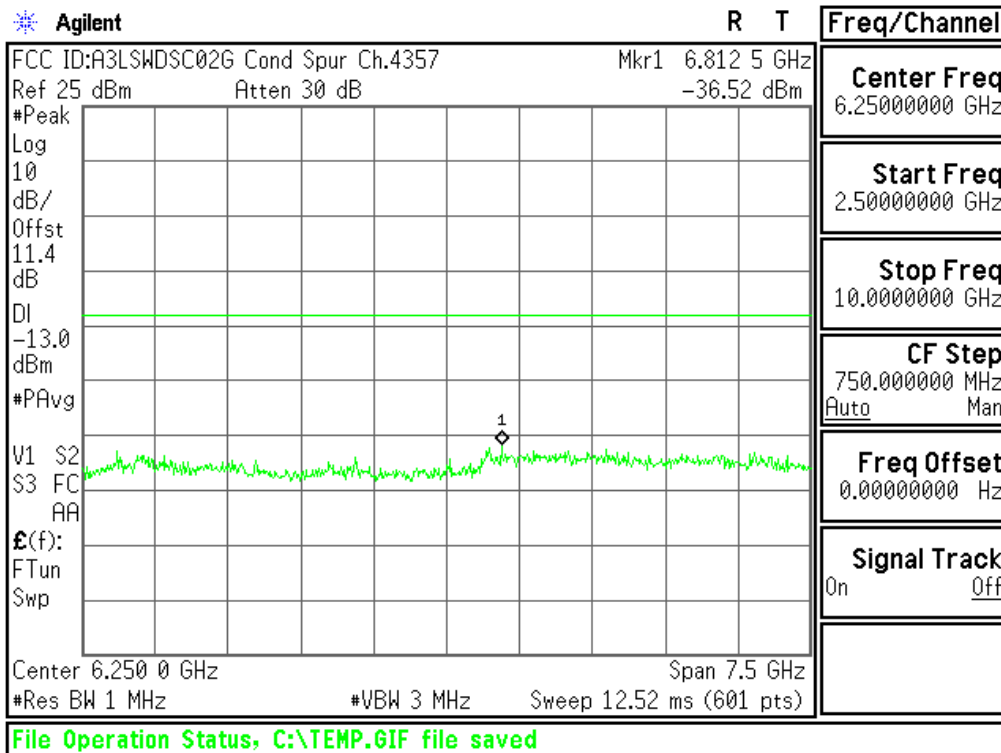

Plot 6-21. Conducted Spurious Plot (Cellular WCDMA Mode - Ch.4132(DL4357))



Issue Date:

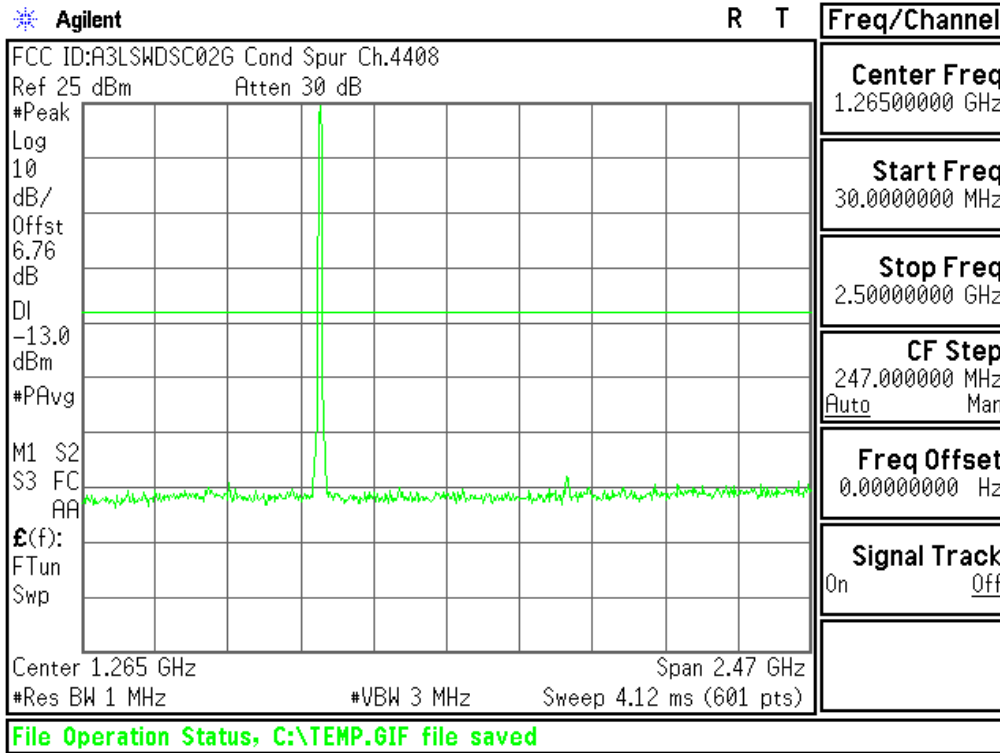

Plot 6-22. Conducted Spurious Plot (Cellular WCDMA Mode - Ch.4183(DL4408))

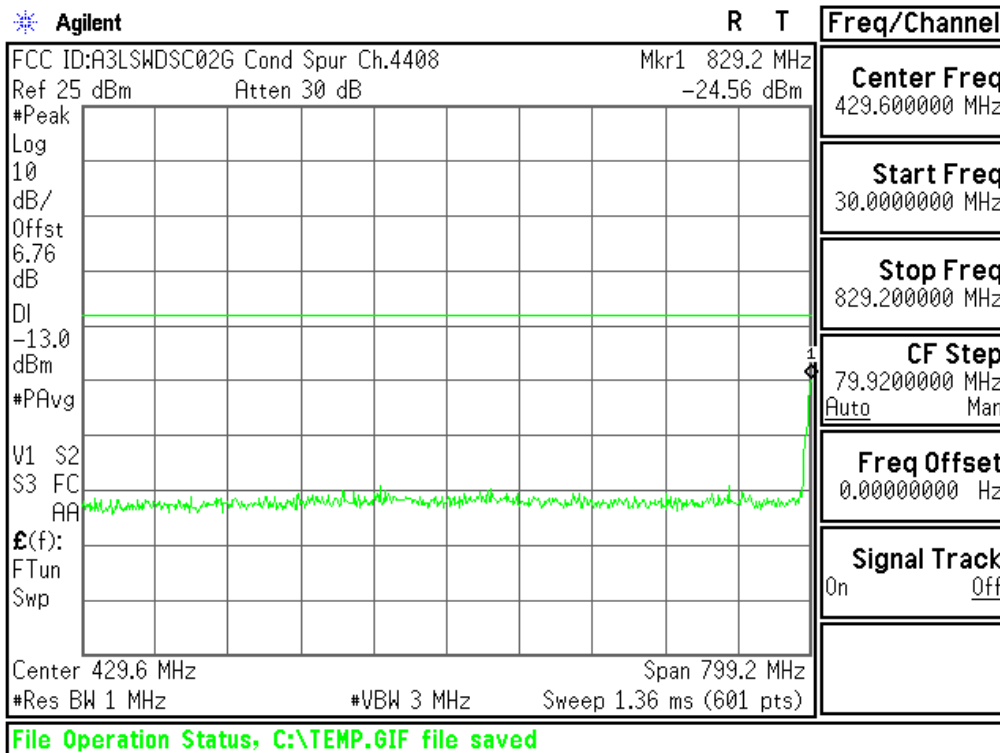

Plot 6-23. Conducted Spurious Plot (Cellular WCDMA Mode - Ch.4183(DL4408))



Issue Date:

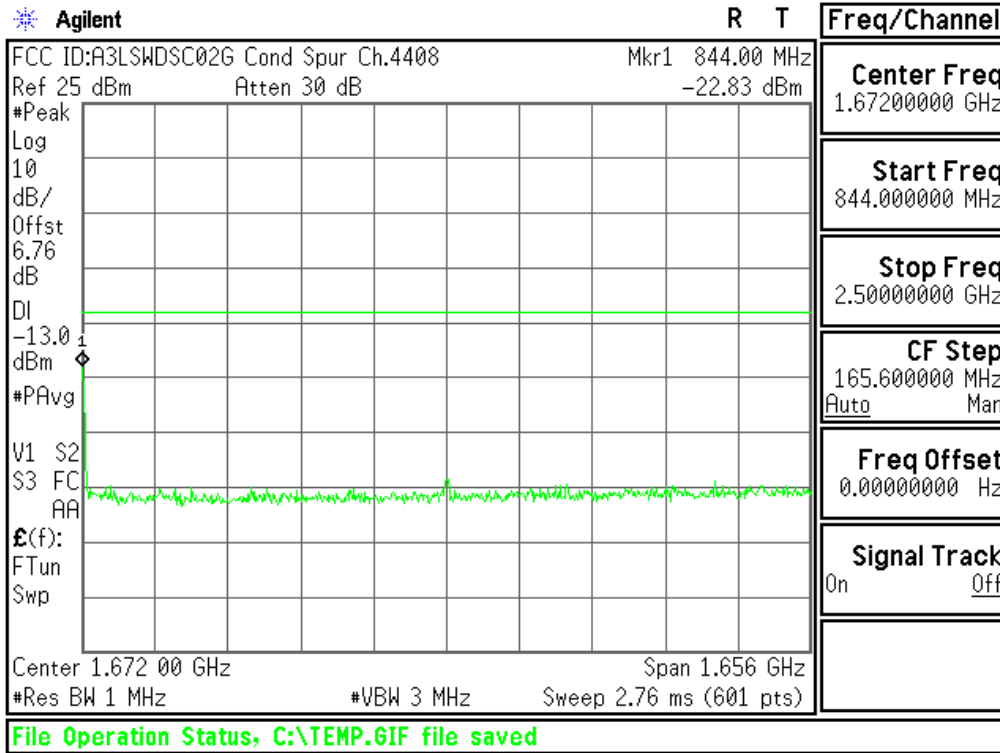

Plot 6-24. Conducted Spurious Plot (Cellular WCDMA Mode - Ch.4183(DL4408))

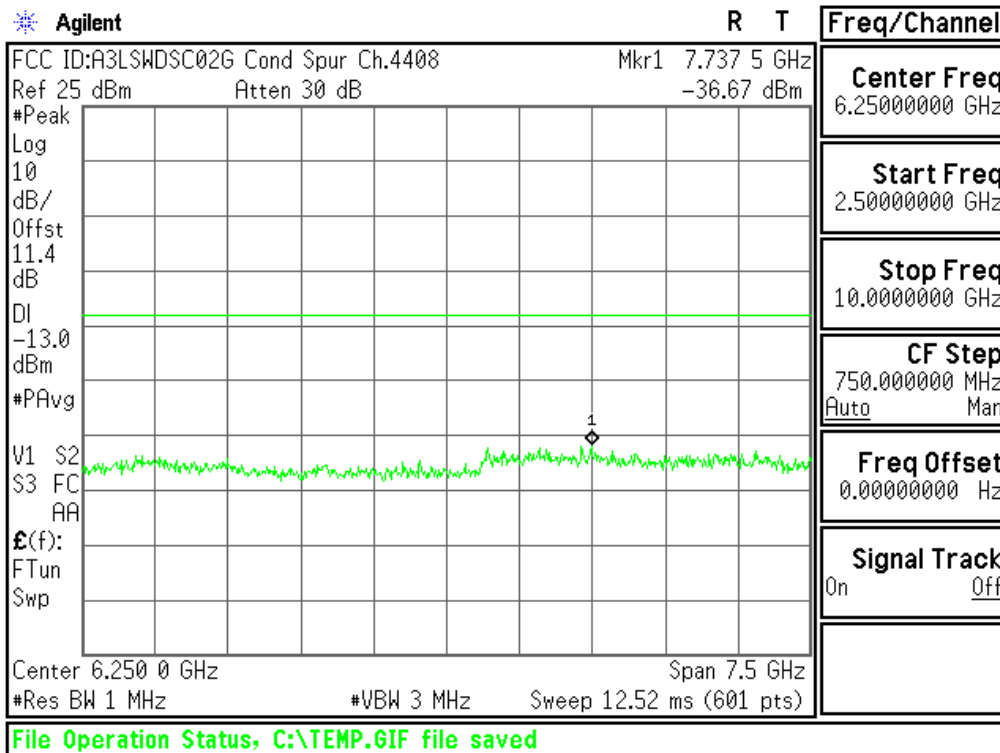

Plot 6-25. Conducted Spurious Plot (Cellular WCDMA Mode - Ch.4183(DL4408))



Issue Date:

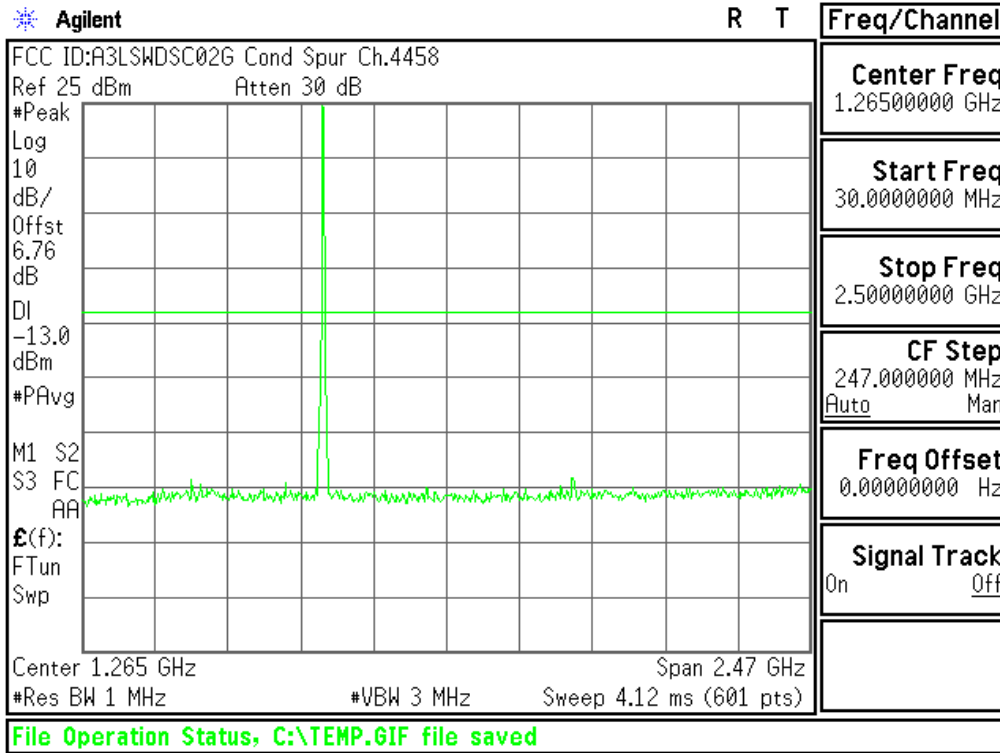

Plot 6-26. Conducted Spurious Plot (Cellular WCDMA Mode - Ch.4233(DL4458))

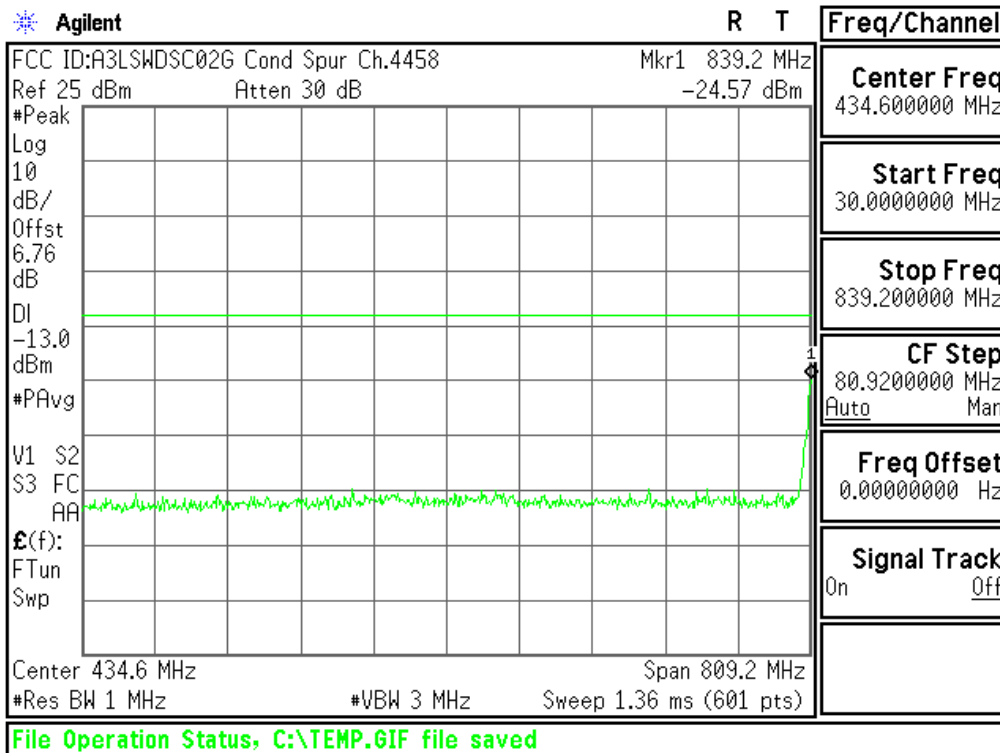

Plot 6-27. Conducted Spurious Plot (Cellular WCDMA Mode - Ch.4233(DL4458))



Issue Date:

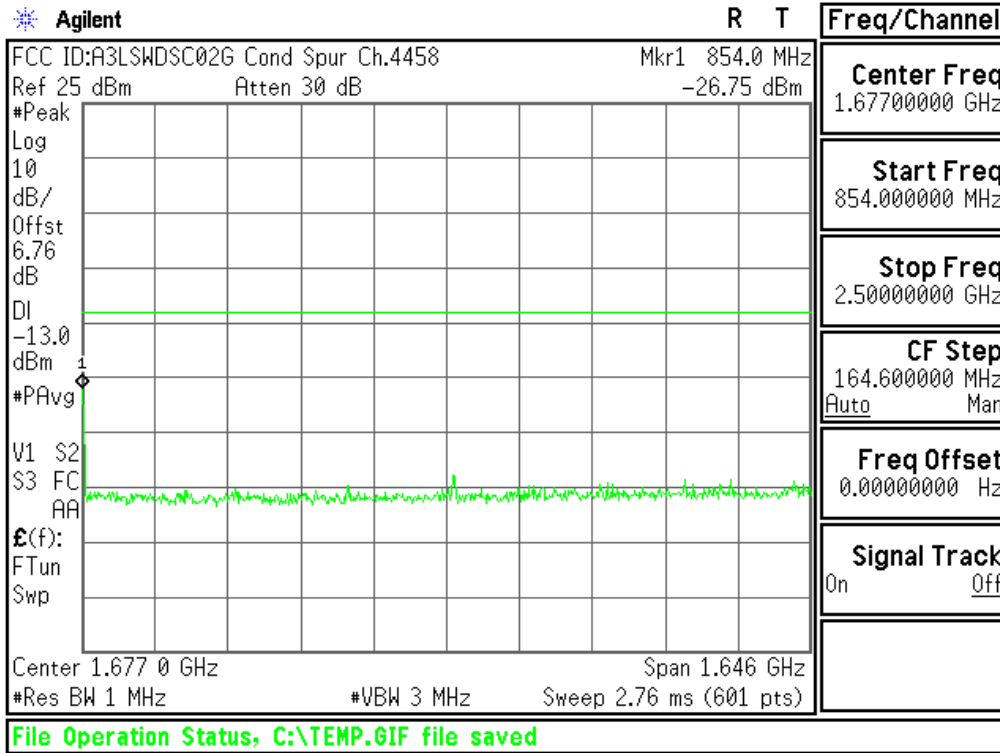

Plot 6-28. Conducted Spurious Plot (Cellular WCDMA Mode - Ch.4233(DL4458))

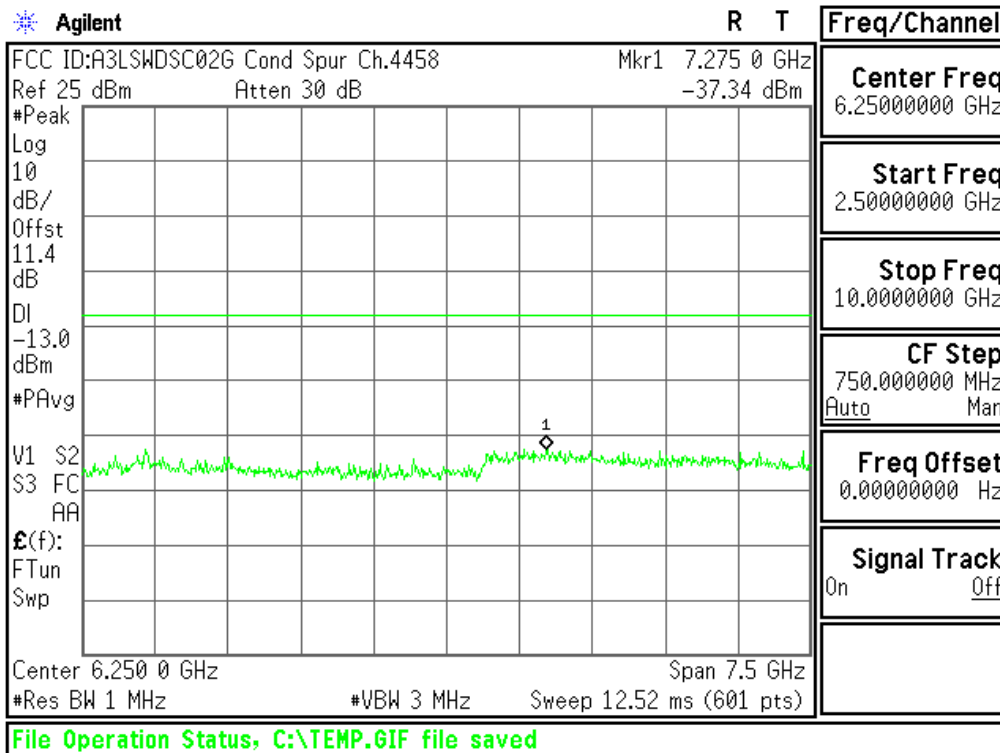

Plot 6-29. Conducted Spurious Plot (Cellular WCDMA Mode - Ch.4233(DL4458))



#### 6.4. Band Edge Emissions at Antenna Terminal §2.1051 § 22.917(a) §24.238(a)

##### Test Overview

All out of band emissions are measured with a spectrum analyzer connected to the antenna terminal of the EUT while the EUT is operating at its maximum duty cycle, at maximum power, and at the appropriate frequencies. All data rates were investigated to determine the worst case configuration. All modes of operation were investigated and the worst case configuration results are reported in this section.

The minimum permissible attenuation level of any spurious emission is  $43 + \log_{10}(P_{\text{[Watts]}})$ , where P is the transmitter power in Watts. Limit equivalent to -13dBm, calculation shown below.

$$43 + 10 \log_{10}(1.567\text{W}) = 44.95 \text{ dB}$$

$$1.567\text{W} = 31.95 \text{ dBm}$$

$$31.95 \text{ dBm} - 44.95 \text{ dB} = -13 \text{ dBm}$$

##### Test Procedure Used

KDB 971168 v02r01 – Section 6.0

##### Test Settings

1. Start and stop frequency were set such that the band edge would be placed at the edge of the plot for GSM, in the center of the plot for WCDMA.
2. Span was set large enough so as to capture all out of band emissions near the band edge
3. RBW > 1% of the emission bandwidth
4. VBW  $\geq 3 \times$  RBW
5. Detector = RMS
6. Number of sweep points  $\geq 2 \times$  Span/RBW
7. Trace mode = max hold
8. Sweep time = auto couple
9. The trace was allowed to stabilize

### Test Setup

The EUT and measurement equipment were set up as shown in the diagram below.

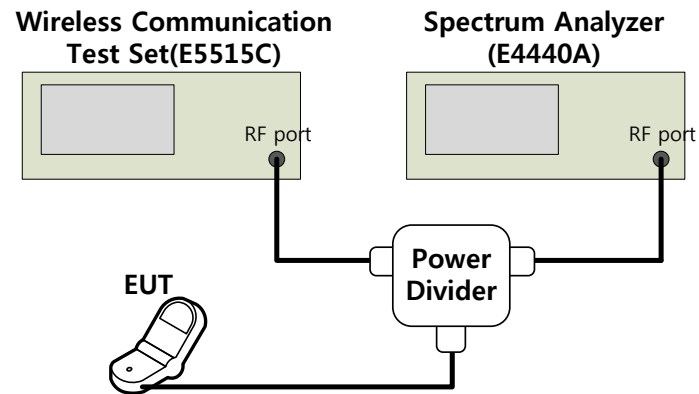

Figure 6-3. Test Instruments & Measurement Setup

### Test Notes

1. Per 22.917(b) and 24.238(b), in the 1 MHz bands immediately outside and adjacent to the frequency block a resolution bandwidth of at least one percent of the emission bandwidth of the fundamental emission of the transmitter may be employed to demonstrate compliance with the out-of-band emissions limit.

Example:

In Case of GSM,  $0.01 \times 273 \text{ KHz} = 2.73 \text{ KHz}$

A resolution BW of 3 KHz was used for measurement at the band edges.



Issue Date:

Test Plots

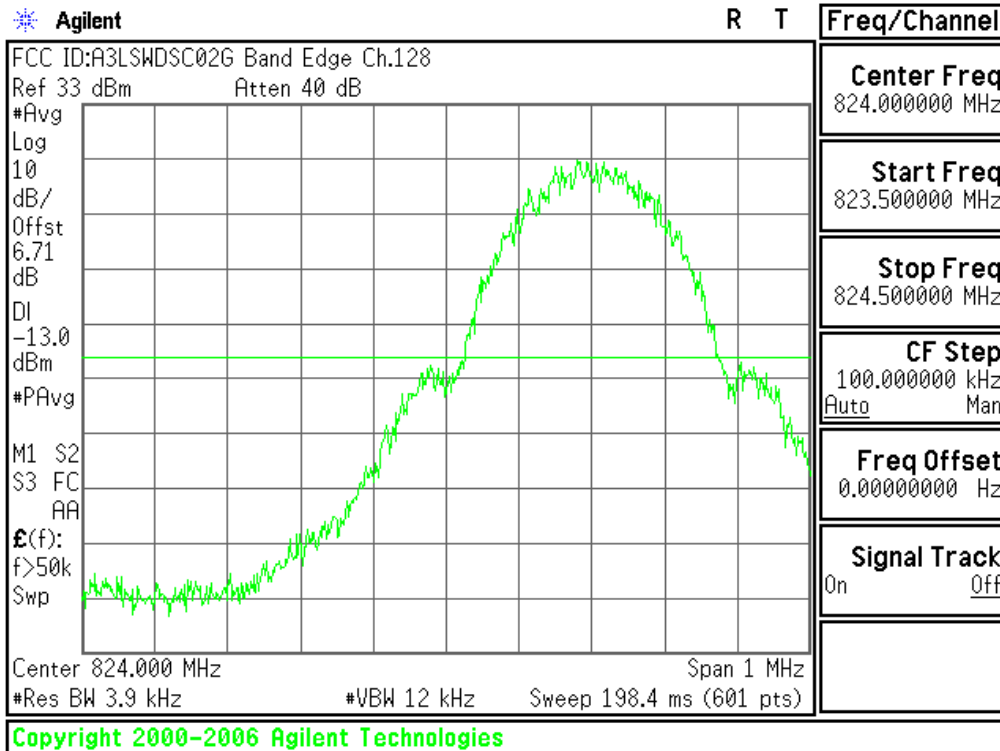

Plot 6-30. Band Edge Plot (Cellular GSM Mode – Ch.128)

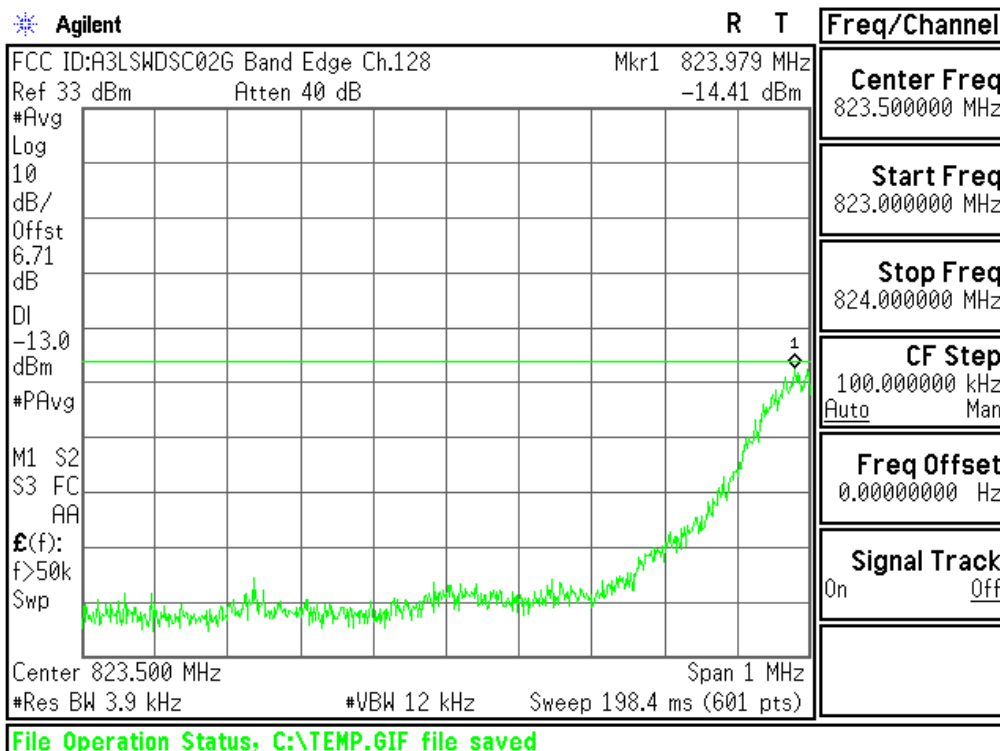

Plot 6-31. Band Edge Plot (Cellular GSM Mode – Ch.128)



Issue Date:

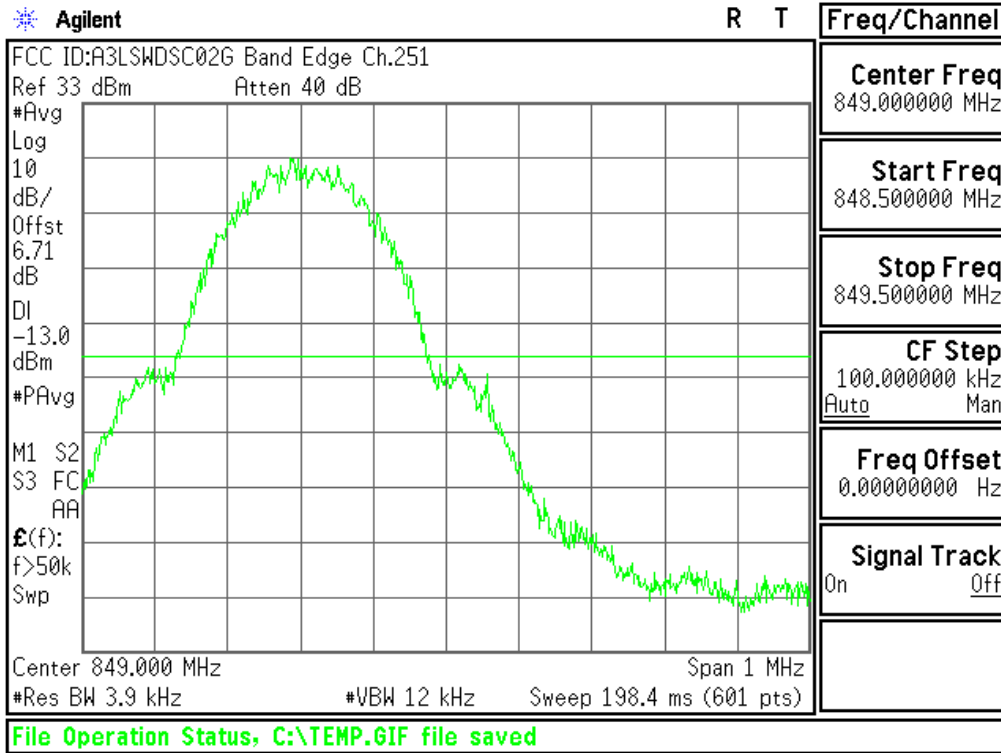

Plot 6-32. Band Edge Plot (Cellular GSM Mode – Ch.251)

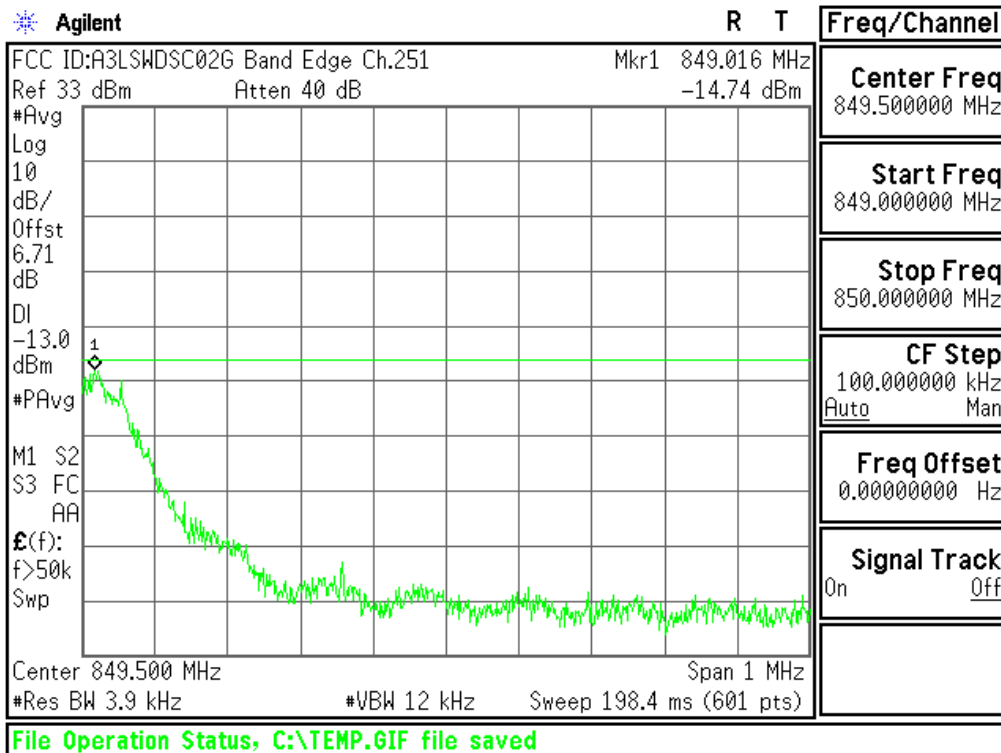

Plot 6-33. Band Edge Plot (Cellular GSM Mode – Ch.251)



Issue Date:

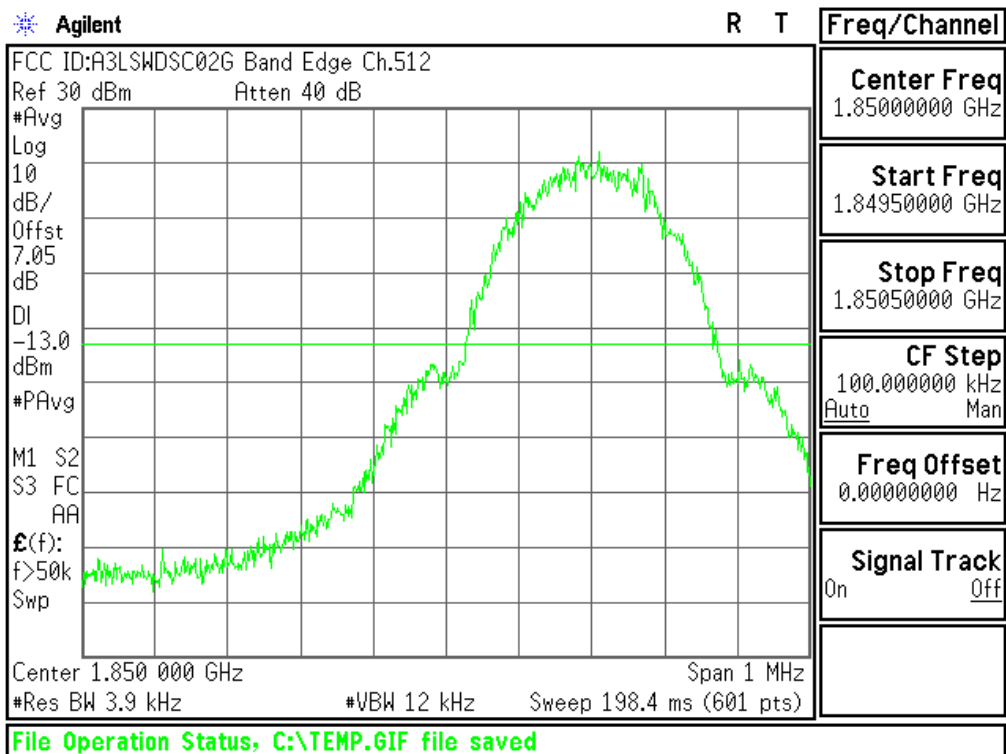

Plot 6-34. Band Edge Plot (PCS GSM Mode – Ch.512)

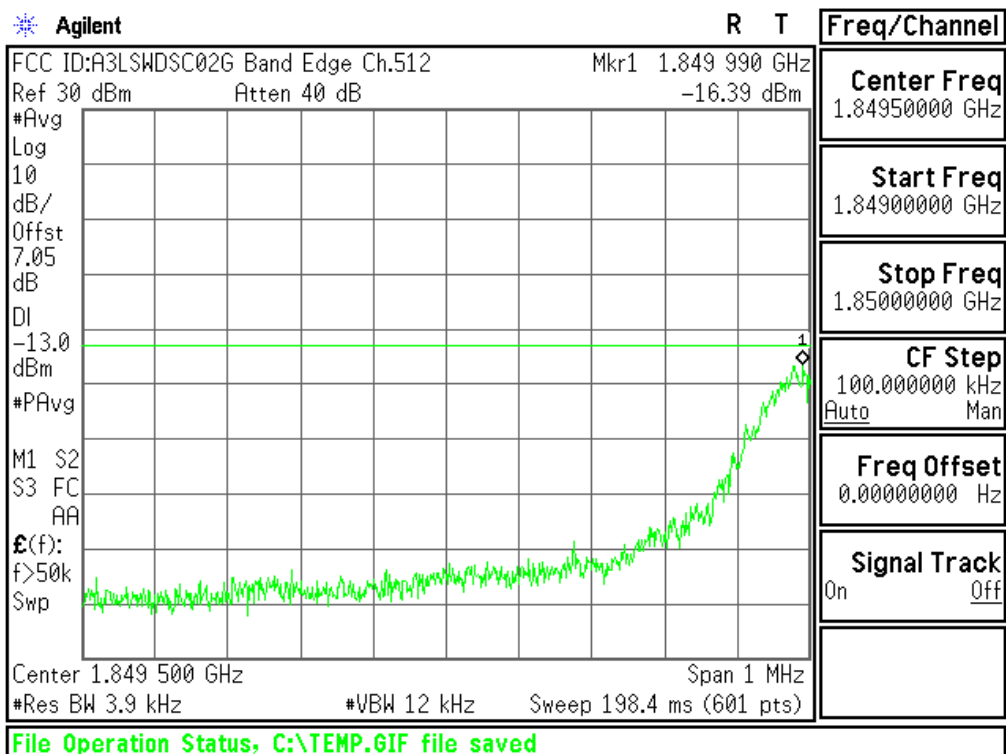

Plot 6-35. Band Edge Plot (PCS GSM Mode – Ch.512)



Issue Date:

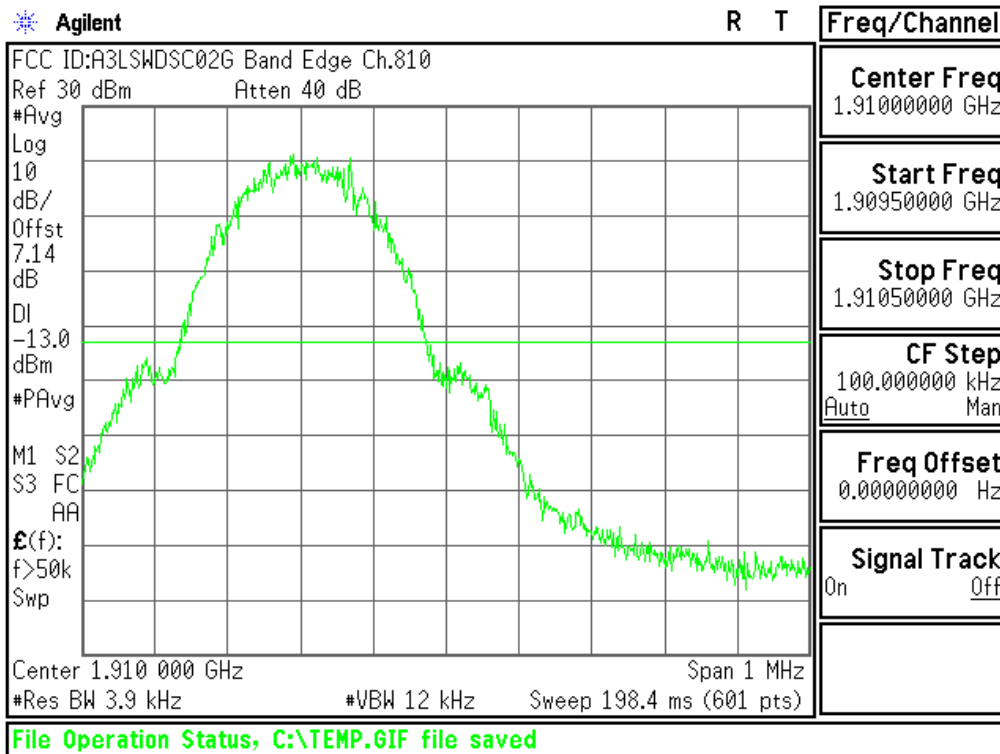

Plot 6-36. Band Edge Plot (PCS GSM Mode – Ch.810)

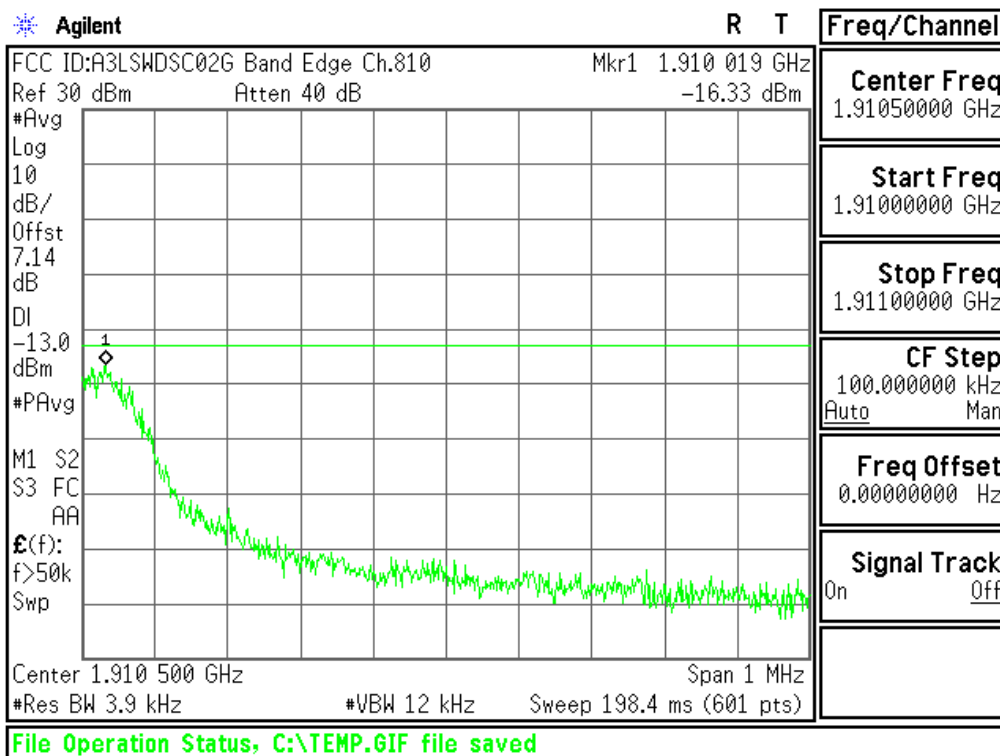

Plot 6-37. Band Edge Plot (PCS GSM Mode – Ch.810)



Issue Date:

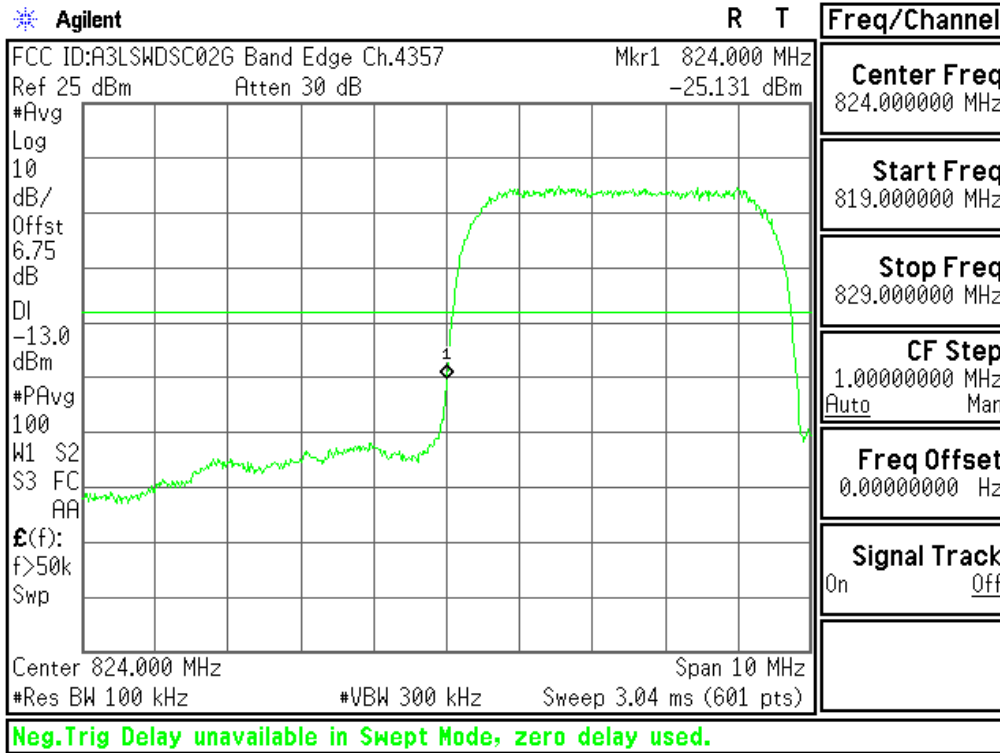

Plot 6-38. Band Edge Plot (Cellular WCDMA Mode - Ch.4132(DL4357))

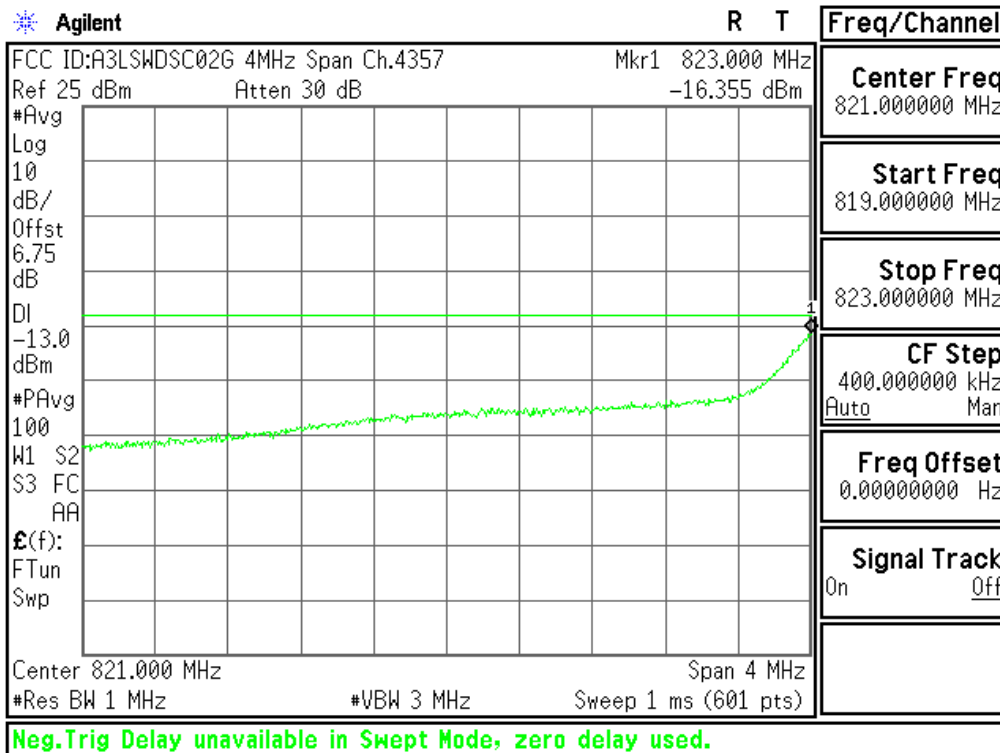

Plot 6-39. 4MHz Span Plot (Cellular WCDMA Mode - Ch.4132(DL4357))



Issue Date:

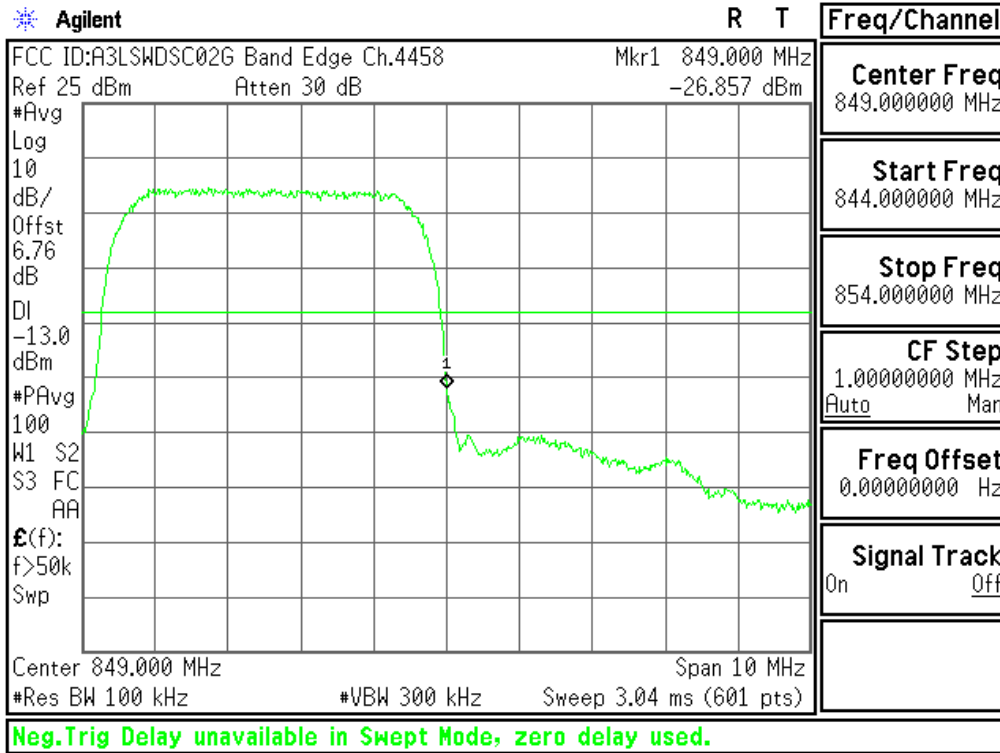

Plot 6-40. Band Edge Plot (Cellular WCDMA Mode - Ch.4233(DL4458))

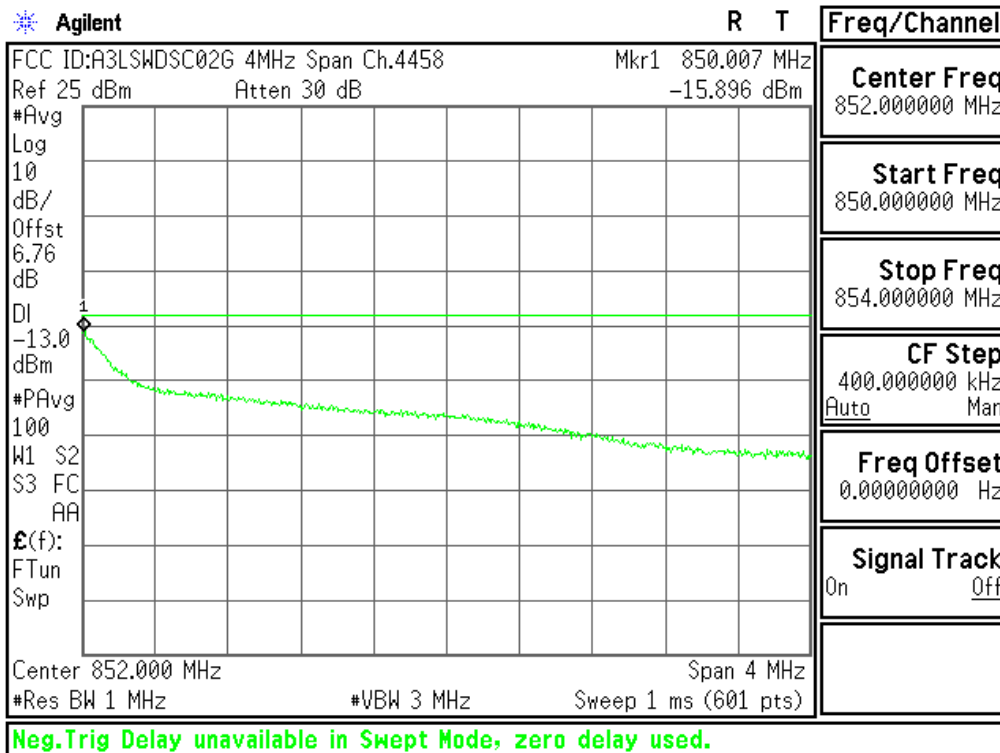

Plot 6-41. 4MHz Span Plot (Cellular WCDMA Mode - Ch.4233(DL4458))

6.5. Peak-Average Ratio(GSM/EDGE)  
§24.232(d)

Test Overview

A peak to average ratio measurement is performed at the conducted port of the EUT. An average and a peak trace are used on a spectrum analyzer to determine the largest deviation between the average and the peak power of the EUT in a given bandwidth. Determine the PAPR from:

$$PAPR_{[dB]} = P_{Pk_{[dBm]}} - P_{Avg_{[dBm]}}$$

Where  $P_{Pk}$  is the total peak power and  $P_{Avg}$  is the total average power.

Test Procedure Used

KDB 971168 v02r01 – Section 5.7.2

Test Settings

1. Frequency = carrier center frequency
2. RBW > OBW
3. VBW  $\geq$  3 x RBW
4. Set span to zero, trigger to “RF Burst” and trigger delay to  $-202\mu s$  to capture all RF burst.
5. Trace 1 mode = Max hold, Detector = Average (RMS)
6. Trace 2 mode = Max hold, Detector = Max Peak
7. Use delta marker to determine the PAPR.

Test Setup

The EUT and measurement equipment were set up as shown in the diagram below.

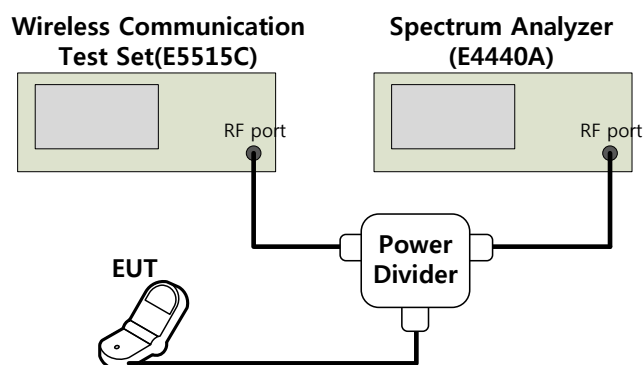
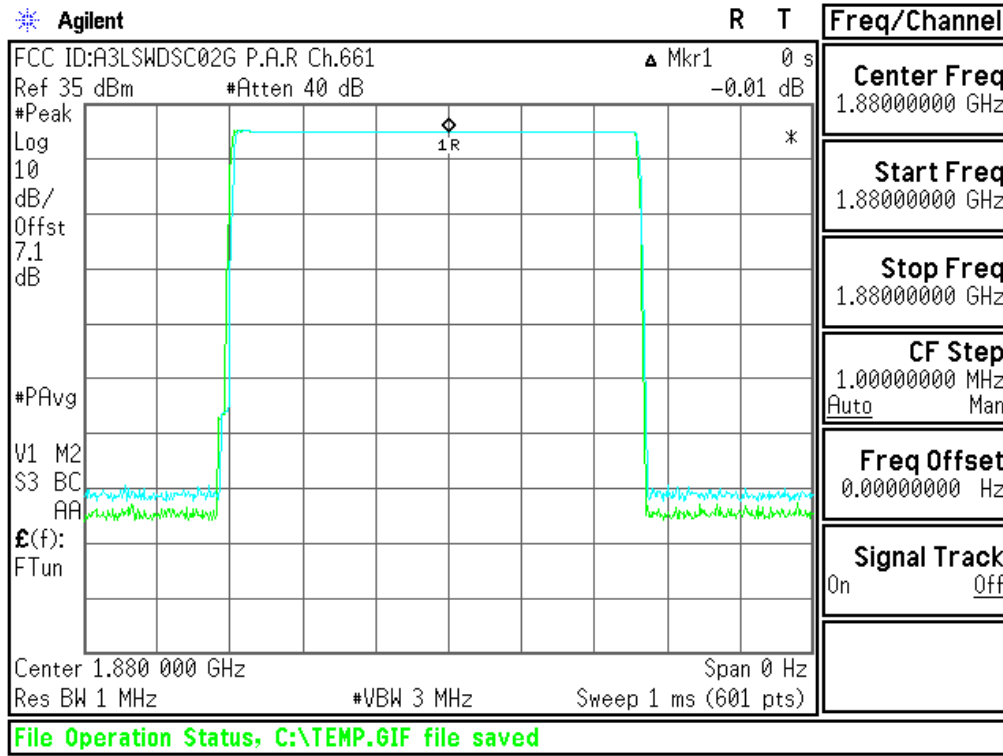

Figure 6-4. Test Instruments & Measurement Setup



Issue Date:

Test Plots



Plot 6-42. Peak-Average Ratio Plot (PCS GSM Mode - Ch.661)

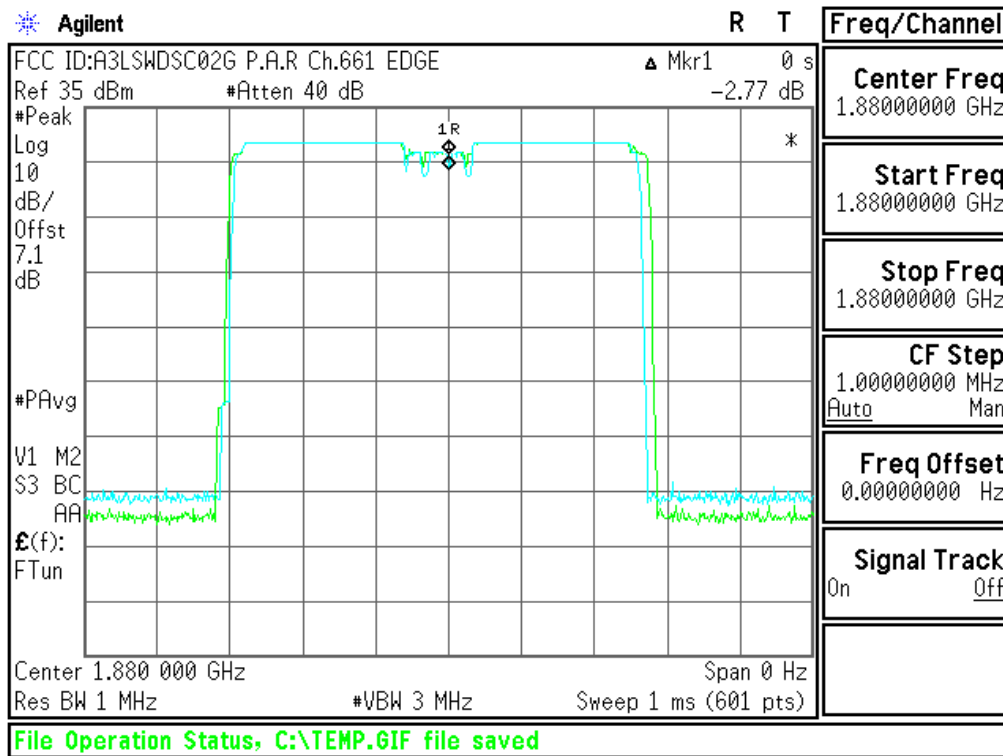

Plot 6-43. Peak-Average Ratio Plot (EDGE1900 Mode - Ch.661)



6.6. Frequency Stability / Temperature Variation  
§2.1055 §22.355 §24.229 §24.235

Test Overview and Limit

Frequency stability testing is performed in accordance with the guidelines of ANSI/TIA-603-C-2004. The frequency stability of the transmitter is measured by:

1. Temperature: The temperature is varied from  $-30^{\circ}\text{C}$  to  $+50^{\circ}\text{C}$  in  $10^{\circ}\text{C}$  increments using an environmental chamber.
2. Primary Supply Voltage: The primary supply voltage is varied from 85% to 115% of the nominal value for other than hand carried battery equipment. For hand-carried, battery-powered equipment, primary supply voltage is reduced to the battery operating end point(=Batt.End) which shall be specified by the manufacturer.

For part 22, the frequency stability of the transmitter shall be maintained within  $\pm 0.00025\%$  ( $\pm 2.5$  ppm) of the center frequency. For part 24, the frequency stability shall be sufficient to ensure that the fundamental emission stays within the authorized frequency block.

Test Procedure Used

ANSI/TIA-603-C-2004

Test Settings

1. The carrier frequency of the transmitter is measured at room temperature ( $20^{\circ}\text{C}$  to provide a reference).
2. The equipment is turned on in a "standby" condition for fifteen minutes before applying power to the transmitter. Measurement of the carrier frequency of the transmitter is made within one minute after applying power to the transmitter.
3. Frequency measurements are made at  $10^{\circ}\text{C}$  intervals ranging from  $-30^{\circ}\text{C}$  to  $+50^{\circ}\text{C}$ . A period of at least one half-hour is provided to allow stabilization of the equipment at each temperature level.

Test Setup

The EUT and measurement equipment were set up as shown in the diagram below.

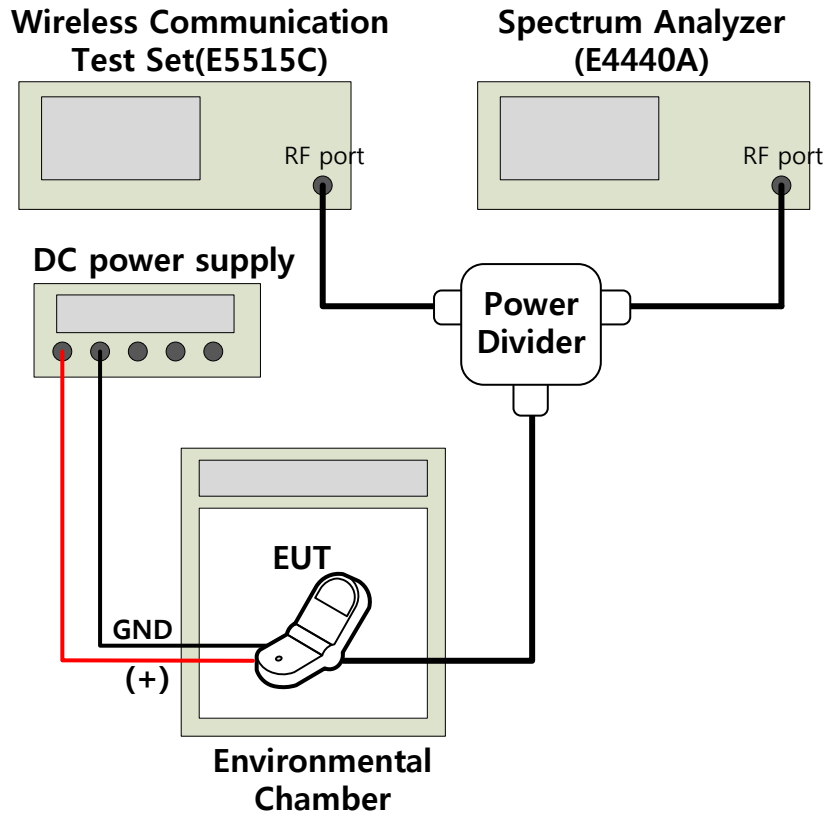

Figure 6-5. Test Instruments & Measurement Setup

Test Notes

1. MCF is the Measured Carrier Frequency  
ACF is the Assigned Carrier Frequency
2. MCF<sub>MAX</sub> in the tables below is the worst-case value among 1000 measurements.
3. Calculate the ppm frequency error by the following:

$$\text{ppm error} = \left( \frac{\text{MCF}_{[\text{MHz}]}}{\text{ACF}_{[\text{MHz}]}} - 1 \right) \times 10^6$$



Issue Date:

Test Results

Mode : Cellular GSM  
 Channel : 190  
 Operating Frequency : 836.6 MHz  
 Reference Voltage : 3.8 VDC

Voltage [%]	Power [VDC]	Temp [°C]	ACF [MHz]	MCF <sub>MAX</sub> [MHz]	Freq. Dev. [Hz]	ppm error	Limit [ppm]
100 %	3.80	-30	836.6	836.600018	18.26	0.022	±2.5
		-20	836.6	836.600019	19.36	0.023	
		-10	836.6	836.600022	21.97	0.026	
		0	836.6	836.600019	18.67	0.022	
		+10	836.6	836.600018	18.17	0.022	
		<b>+20</b>	836.6	836.600018	17.62	0.021	
		+30	836.6	836.600020	19.59	0.023	
		+40	836.6	836.600020	20.19	0.024	
		+50	836.6	836.600019	19.09	0.023	
Batt.End	3.40	+20	836.6	836.600019	19.43	0.023	

Table 6-2. Frequency Stability Data (Cellular GSM Mode - Ch.190)

Mode : Cellular WCDMA  
 Channel : 4183  
 Operating Frequency : 836.6 MHz  
 Reference Voltage : 3.8 VDC

Voltage [%]	Power [VDC]	Temp [°C]	ACF [MHz]	MCF <sub>MAX</sub> [MHz]	Freq. Dev. [Hz]	ppm error	Limit [ppm]
100 %	3.80	-30	836.6	836.599996	-4.17	-0.005	±2.5
		-20	836.6	836.599996	-3.85	-0.005	
		-10	836.6	836.599996	-3.83	-0.005	
		0	836.6	836.599995	-4.85	-0.006	
		+10	836.6	836.599995	-4.75	-0.006	
		<b>+20</b>	836.6	836.599996	-4.47	-0.005	
		+30	836.6	836.599994	-5.89	-0.007	
		+40	836.6	836.599995	-5.50	-0.007	
		+50	836.6	836.599996	-4.12	-0.005	
Batt.End	3.40	+20	836.6	836.599996	-4.13	-0.005	

Table 6-3. Frequency Stability Data (Cellular WCDMA Mode - Ch.4183)



Issue Date:

Mode : PCS GSM  
Channel : 661  
Operating Frequency : 1880 MHz  
Reference Voltage : 3.8 VDC

Voltage [%]	Power [VDC]	Temp [°C]	ACF [MHz]	MCF <sub>MAX</sub> [MHz]	Freq. Dev. [Hz]	ppm error
100 %	3.80	-30	1880	1,880.000057	57.31	0.030
		-20	1880	1,880.000060	59.92	0.032
		-10	1880	1,880.000064	63.94	0.034
		0	1880	1,880.000059	58.66	0.031
		+10	1880	1,880.000058	57.73	0.031
		<b>+20</b>	1880	1,880.000061	60.59	0.032
		+30	1880	1,880.000064	63.56	0.034
		+40	1880	1,880.000061	60.66	0.032
		+50	1880	1,880.000060	59.97	0.032
Batt.End	3.40	+20	1880	1,880.000058	57.62	0.031

Table 6-4. Frequency Stability Data (PCS GSM Mode - Ch.661)

**Note:**

Based on the results of the frequency stability test at the center channel, the frequency deviation results measured are very small. As such it is determined that the channels at the band edge would remain in-band when the maximum measured frequency deviation noted during the frequency stability tests is applied. Therefore the device is determined to remain operating in band over the temperature and voltage range as tested.



6.7. Radiated Power (ERP/EIRP)  
§22.913(a)(2) §24.232(c)

Test Overview

Effective Radiated Power (ERP) and Equivalent Isotropic Radiated Power (EIRP) measurements are performed using the substitution method described in ANSI/TIA-603-C-2004 with the EUT transmitting into an integral antenna. Measurements on signals operating below 1GHz are performed using dipole antennas. Measurements on signals operating above 1GHz are performed using broadband horn antennas. All measurements are performed as RMS average measurements while the EUT is operating at its maximum duty cycle, at maximum power, and at the appropriate frequencies.

Test Procedure Used

KDB 971168 v02r01 – Section 5.2.1

ANSI/TIA-603-C-2004 – Section 2.2.17

Test Settings

1. Radiated power measurements are performed using the signal analyzer's "channel power" measurement capability for signals with continuous operation. For signals with burst transmission, the signal analyzer's "time domain power" measurement capability is used
2. RBW = 1 – 5% of the expected OBW, not to exceed 1MHz
3. VBW > 3 x RBW
4. Span = 1.5 times the OBW
5. No. of sweep points > 2 x span / RBW
6. Detector = RMS
7. Trigger is set to "free run" for signals with continuous operation with the sweep times set to "auto". Trigger is set to enable triggering only on full power bursts with the sweep time set less than or equal to the transmission burst duration
8. The integration bandwidth was roughly set equal to the measured OBW of the signal for signals with continuous operation. For signals with burst transmission, the "gating" function was enabled to ensure that measurements are performed during times in which the transmitter is operating at its maximum power
9. Trace mode = trace averaging (RMS) over 100 sweeps
10. The trace was allowed to stabilize

Test Setup

The EUT and measurement equipment were set up as shown in the diagram below.

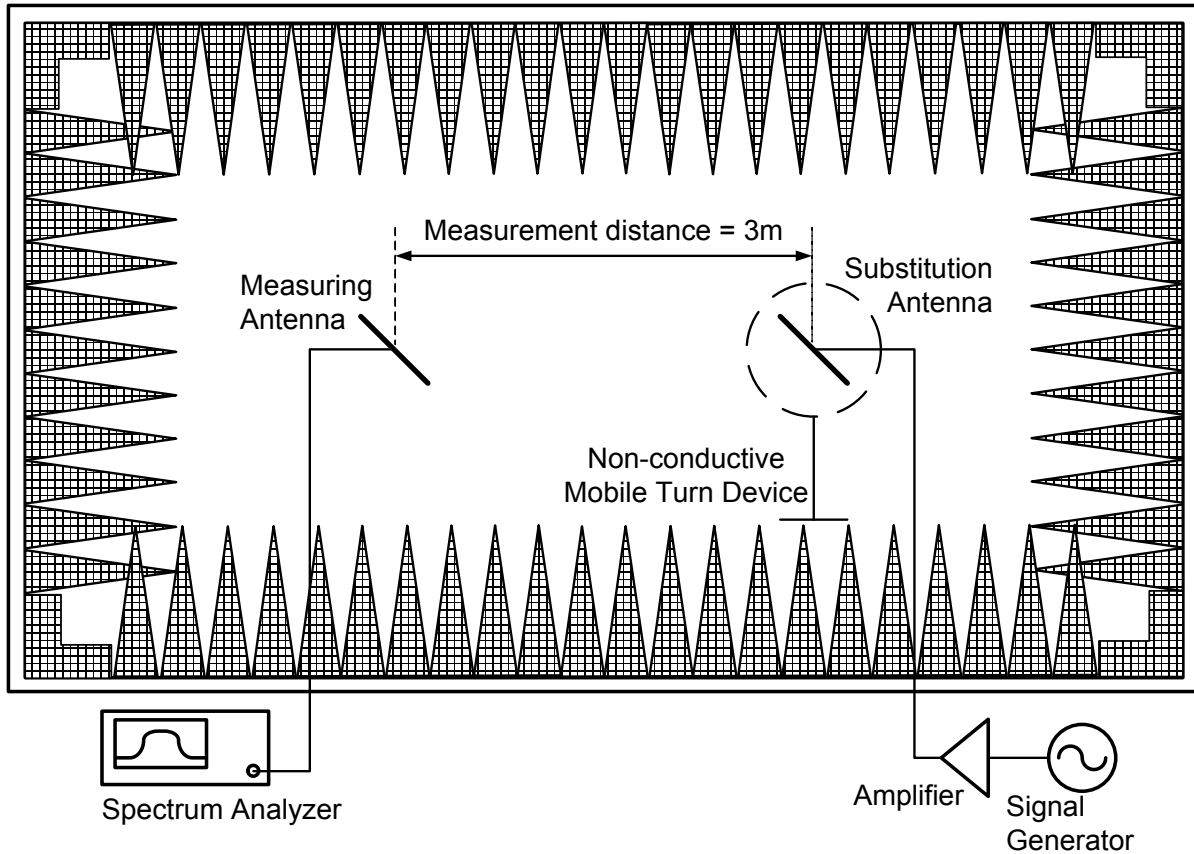

Figure 6-6. Test Instruments & Measurement Setup

Test Notes

1. This device employs GSM, GPRS and EDGE capabilities. The EUT was tested under all configurations and the highest power is reported in GSM mode using a Power Control Level of "0" in the PCS Band and "5" in the Cellular Band.
2. This device employs UMTS technology with WCDMA (AMR/RMC), HSDPA and HSUPA capabilities. For WCDMA and HSUPA transmission, all configurations were investigated and the worst case UMTS emissions were found in RMC WCDMA mode at 12.2kbps with HSDPA inactive and TPC bits all set to "1".
3. The battery used with this device for testing (Model: EB-BG870BBD) contains an embedded NFC antenna.
4. The EUT was tested with Mobile Turn Device and the worst case test setup is reported in the tables below.



Issue Date:

Test Results

Mode	Freq. [MHz]	Ant Pol (H/V)	EUT Pol [degree]		S/A Reading [dBm]	S/G +AMP [dBm]	Tx C/L [dB]	Ant. Gain [dBd]	ERP [dBm]	ERP Limit [dBm]	Margin [dB]
			Azimuth	Elevation							
GSM850	824.2	H	90	260	-6.13	31.94	3.10	-0.75	28.09	38.45	-10.36
GSM850	836.6	H	310	90	-4.93	33.18	3.12	-0.77	29.28	38.45	-9.17
GSM850	848.8	H	90	300	-5.89	32.26	3.15	-0.80	28.31	38.45	-10.14
EDGE850	836.6	H	310	70	-11.15	26.96	3.12	-0.77	23.06	38.45	-15.39

Table 6-5. ERP (Cellular GSM)

Mode	Freq. [MHz]	Ant Pol (H/V)	EUT Pol [degree]		S/A Reading [dBm]	S/G +AMP [dBm]	Tx C/L [dB]	Ant. Gain [dBi]	EIRP [dBm]	ERP Limit [dBm]	Margin [dB]
			Azimuth	Elevation							
GSM1900	1850.2	H	13	0	-14.10	24.98	4.75	10.26	30.49	33.01	-2.52
GSM1900	1880	H	0	0	-13.70	25.34	4.80	10.33	30.87	33.01	-2.14
GSM1900	1909.8	H	0	0	-14.51	24.63	4.84	10.38	30.17	33.01	-2.84
EDGE1900	1880	H	0	10	-16.39	22.65	4.80	10.33	28.18	33.01	-4.83

Table 6-6. EIRP (PCS GSM)

Mode	Freq. [MHz]	Ant Pol (H/V)	EUT Pol [degree]		S/A Reading [dBm]	S/G Lev. [dBm]	Tx C/L [dB]	Ant. Gain [dBd]	ERP [dBm]	ERP Limit [dBm]	Margin [dB]
			Azimuth	Elevation							
WCDMA850	826.4	H	80	275	-13.86	24.22	3.10	-0.75	20.36	38.45	-18.09
WCDMA850	836.6	H	85	275	-13.15	24.96	3.12	-0.77	21.06	38.45	-17.39
WCDMA850	846.6	H	56	270	-14.16	23.98	3.14	-0.80	20.04	38.45	-18.41

Table 6-7. ERP (Cellular WCDMA)



6.8. Radiated Spurious Emissions Measurements  
§2.1053 §22.917(a) §24.238(a)

Test Overview

Radiated spurious emissions measurements are performed using the substitution method described in ANSI/TIA-603-C-2004 with the EUT transmitting into an integral antenna. Measurements on signals operating below 1GHz are performed using dipole antennas. Measurements on signals operating above 1GHz are performed using broadband horn antennas. All measurements are performed as peak measurements while the EUT is operating at its maximum duty cycle, at maximum power, and at the appropriate frequencies.

Test Procedure Used

KDB 971168 v02r01 – Section 5.8

ANSI/TIA-603-C-2004 – Section 2.2.12

Test Settings

1. RBW = 100kHz for emissions below 1GHz and 1MHz for emissions above 1GHz
2. VBW  $\geq 3 \times$  RBW
3. Span = 1.5 times the OBW
4. No. of sweep points  $\geq 2 \times$  span / RBW
5. Detector = Max Peak
6. Trace mode = max hold
7. The trace was allowed to stabilize

Test Setup

The EUT and measurement equipment were set up as shown in the diagram below.

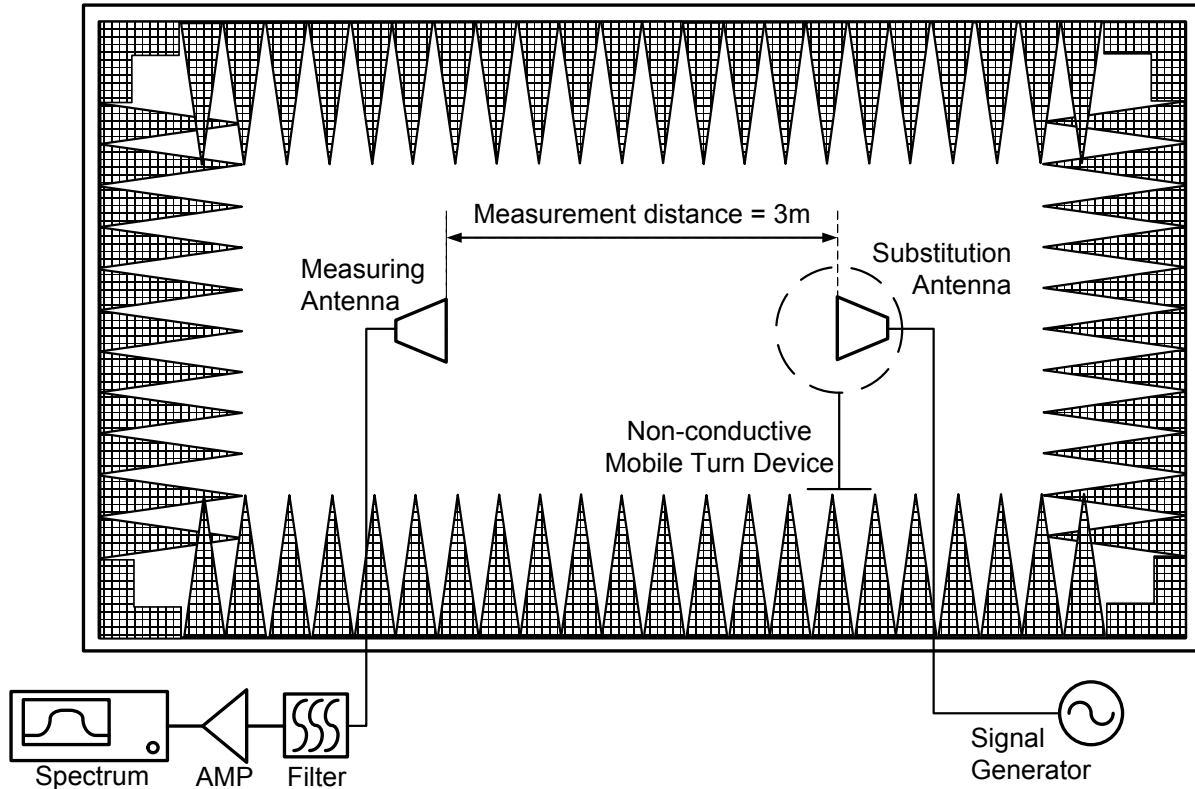

Figure 6-7. Test Instruments & Measurement Setup

Test Notes

1. This device employs GSM, GPRS and EDGE capabilities. The EUT was tested under all configurations and the highest power is reported in GSM mode using a Power Control Level of "0" in the PCS Band and "5" in the Cellular Band.
2. This device employs UMTS technology with WCDMA (AMR/RMC), HSDPA and HSUPA capabilities. For WCDMA and HSUPA transmission, all configurations were investigated and the worst case UMTS emissions were found in RMC WCDMA mode at 12.2kbps with HSDPA inactive and TPC bits all set to "1".
3. The battery used with this device for testing (Model: EB-BG870BBD) contains an embedded NFC antenna.
4. The EUT was tested with Mobile Turn Device and the worst case test setup is reported in the tables below.
5. The spectrum is measured from 9kHz to the 10<sup>th</sup> harmonic of the fundamental frequency of the transmitter. The worst-case emissions are reported however emissions whose levels were not within 20dB of the respective limits were not reported.



Issue Date:

Test Results

Operating Frequency : 824.20 MHz  
 Channel : 128  
 Measured Output Power : 28.09 dBm = 0.644 Watt  
 Modulation Signal : GSM(GMSK)  
 Distance : 3 meters  
 Limit :  $43 + 10 \log_{10}(W)$  = 41.09 dBc

Freq. [MHz]	Ant Pol (H/V)	EUT Pol [degree]		S/A reading [dBm]	S/G Lev. [dBm]	Tx C/L [dB]	Ant. Gain [dBd]	RSE Level [dBm]	[dBc]
		Azimuth	Elevation						
1648.40	V	75	257	-57.23	-55.90	4.48	7.47	-52.90	80.99
2472.60	V	75	310	-59.79	-53.89	5.56	8.35	-51.10	79.19
3296.80	H	15	320	-67.14	-57.70	6.50	10.21	-53.99	82.08
4121.00	V	55	315	-66.19	-52.32	7.29	10.52	-49.10	77.19

Table 6-8. Radiated Spurious Data (Cellular GSM Mode - Ch.128)

Operating Frequency : 836.60 MHz  
 Channel : 190  
 Measured Output Power : 29.28 dBm = 0.847 Watt  
 Modulation Signal : GSM(GMSK)  
 Distance : 3 meters  
 Limit :  $43 + 10 \log_{10}(W)$  = 42.28 dBc

Freq. [MHz]	Ant Pol (H/V)	EUT Pol [degree]		S/A reading [dBm]	S/G Lev. [dBm]	Tx C/L [dB]	Ant. Gain [dBd]	RSE Level [dBm]	[dBc]
		Azimuth	Elevation						
1673.20	V	75	290	-56.64	-55.33	4.51	7.58	-52.26	81.54
2509.80	V	90	310	-58.43	-52.27	5.61	8.37	-49.51	78.79
3346.40	V	0	250	-66.43	-57.25	6.56	10.50	-53.31	82.59
4183.00	V	50	310	-67.49	-53.53	7.43	10.63	-50.33	79.61
5019.60	V	50	310	-68.89	-52.14	8.18	10.46	-49.86	79.14

Table 6-9. Radiated Spurious Data (Cellular GSM Mode - Ch.190)



Issue Date:

Operating Frequency : 848.80 MHz  
 Channel : 251  
 Measured Output Power : 28.31 dBm = 0.678 Watt  
 Modulation Signal : GSM(GMSK)  
 Distance : 3 meters  
 Limit :  $43 + 10 \log_{10}(W)$  = 41.31 dBc

Freq. [MHz]	Ant Pol (H/V)	EUT Pol [degree]		S/A reading [dBm]	S/G Lev. [dBm]	Tx C/L [dB]	Ant. Gain [dBd]	RSE Level [dBm]	[dBc]
		Azimuth	Elevation						
1697.60	V	75	290	-57.40	-56.13	4.55	7.69	-52.98	81.29
2546.40	H	15	290	-60.60	-54.32	5.65	8.39	-51.58	79.89
3395.20	V	0	260	-65.74	-56.30	6.60	10.55	-52.35	80.66
8488.00	V	50	310	-67.26	-53.39	7.51	10.76	-50.14	78.45

Table 6-10. Radiated Spurious Data (Cellular GSM Mode - Ch.251)

Operating Frequency : 1850.20 MHz  
 Channel : 512  
 Measured Output Power : 30.49 dBm = 1.119 Watt  
 Modulation Signal : GSM(GMSK)  
 Distance : 3 meters  
 Limit :  $43 + 10 \log_{10}(W)$  = 43.49 dBc

Freq. [MHz]	Ant Pol (H/V)	EUT Pol [degree]		S/A reading [dBm]	S/G Lev. [dBm]	Tx C/L [dB]	Ant. Gain [dBi]	RSE Level [dBm]	[dBc]
		Azimuth	Elevation						
3700.40	V	93	300	-63.44	-52.14	6.93	12.46	-46.60	77.09
5550.60	V	136	272	-64.84	-46.01	8.53	12.91	-41.62	72.11
7400.80	H	80	295	-68.70	-41.35	9.95	10.32	-40.99	71.48

Table 6-11. Radiated Spurious Data (PCS GSM Mode - Ch.512)



Issue Date:

Operating Frequency : 1880.00 MHz  
 Channel : 661  
 Measured Output Power : 30.87 dBm = 1.222 Watt  
 Modulation Signal : GSM(GMSK)  
 Distance : 3 meters  
 Limit :  $43 + 10 \log_{10}(W)$  = 43.87 dBc

Freq. [MHz]	Ant Pol (H/V)	EUT Pol [degree]		S/A reading [dBm]	S/G Lev. [dBm]	Tx C/L [dB]	Ant. Gain [dBi]	RSE Level [dBm]	[dBc]
		Azimuth	Elevation						
3760.00	V	95	294	-65.91	-54.14	6.93	12.44	-48.63	79.50
5640.00	H	84	293	-65.76	-46.00	8.61	13.14	-41.47	72.34
7520.00	H	85	290	-68.14	-40.47	10.02	10.67	-39.82	70.69

Table 6-12. Radiated Spurious Data (PCS GSM Mode - Ch.661)

Operating Frequency : 1909.80 MHz  
 Channel : 810  
 Measured Output Power : 30.17 dBm = 1.040 Watt  
 Modulation Signal : GSM(GMSK)  
 Distance : 3 meters  
 Limit :  $43 + 10 \log_{10}(W)$  = 43.17 dBc

Freq. [MHz]	Ant Pol (H/V)	EUT Pol [degree]		S/A reading [dBm]	S/G Lev. [dBm]	Tx C/L [dB]	Ant. Gain [dBi]	RSE Level [dBm]	[dBc]
		Azimuth	Elevation						
3819.60	V	96	300	-65.80	-53.97	6.99	12.33	-48.63	78.80
5729.40	H	85	295	-66.00	-45.73	8.69	13.04	-41.38	71.55
7639.20	H	85	295	-68.80	-41.15	10.16	11.20	-40.11	70.28

Table 6-13. Radiated Spurious Data (PCS GSM Mode - Ch.810)



Issue Date:

Operating Frequency : 826.40 MHz  
 Channel : 4132  
 Measured Output Power : 20.36 dBm = 0.109 Watt  
 Modulation Signal : WCDMA  
 Distance : 3 meters  
 Limit :  $43 + 10 \log_{10}(W)$  = 33.36 dBc

Freq. [MHz]	Ant Pol (H/V)	EUT Pol [degree]		S/A reading [dBm]	S/G Lev. [dBm]	Tx C/L [dB]	Ant. Gain [dBd]	RSE Level [dBm]	[dBc]
		Azimuth	Elevation						
1652.80	H	30	300	-64.94	-63.28	4.48	7.49	-60.27	80.63
2479.20	H	Noise Floor		-66.80	-60.46	5.57	8.35	-57.68	78.04
3305.60	H	Noise Floor		-67.43	-57.99	6.51	10.26	-54.23	74.59

Table 6-14. Radiated Spurious Data (Cellular WCDMA Mode - Ch.4132)

Operating Frequency : 836.60 MHz  
 Channel : 4183  
 Measured Output Power : 21.06 dBm = 0.128 Watt  
 Modulation Signal : WCDMA  
 Distance : 3 meters  
 Limit :  $43 + 10 \log_{10}(W)$  = 34.06 dBc

Freq. [MHz]	Ant Pol (H/V)	EUT Pol [degree]		S/A reading [dBm]	S/G Lev. [dBm]	Tx C/L [dB]	Ant. Gain [dBd]	RSE Level [dBm]	[dBc]
		Azimuth	Elevation						
1673.20	H	30	310	-64.52	-62.98	4.51	7.58	-59.91	80.97
2509.80	V	Noise Floor		-67.07	-60.91	5.61	8.37	-58.15	79.21
3346.40	H	Noise Floor		-68.04	-58.50	6.56	10.50	-54.55	75.61

Table 6-15. Radiated Spurious Data (Cellular WCDMA Mode - Ch.4183)

Operating Frequency : 846.60 MHz  
 Channel : 4233  
 Measured Output Power : 20.04 dBm = 0.101 Watt  
 Modulation Signal : WCDMA  
 Distance : 3 meters  
 Limit :  $43 + 10 \log_{10}(W)$  = 33.04 dBc

Freq. [MHz]	Ant Pol (H/V)	EUT Pol [degree]		S/A reading [dBm]	S/G Lev. [dBm]	Tx C/L [dB]	Ant. Gain [dBd]	RSE Level [dBm]	[dBc]
		Azimuth	Elevation						
1693.20	H	30	300	-62.67	-61.25	4.54	7.67	-58.12	78.16
2539.80	H	Noise Floor		-63.07	-56.78	5.64	8.38	-54.03	74.07
3386.40	H	Noise Floor		-64.42	-54.75	6.59	10.54	-50.79	70.83

Table 6-18. Radiated Spurious Data (Cellular WCDMA Mode - Ch.4233)



## **7. CONCLUSION**

The data collected relate only the item(s) tested and show that the Samsung Portable Handset FCC ID: A3LSWDSC02G compliance with all the requirements of Parts 2, 22, 24 of the FCC rules.