



# RADIO TEST REPORT

**Test Report No. : 32BE0278-HO-D**

**Applicant** : SAMSUNG ELECTRONICS CO., LTD.  
**Type of Equipment** : Cellular/PCS GSM/GPRS/EDGE Tablet with 802.11abgn, BT3.0  
**Model No.** : SC-02D  
**FCC ID** : A3LSWDSC02D  
**Test regulation** : FCC Part 15 Subpart E: 2011 (DFS test only)  
**Test Result** : Complied

1. This test report shall not be reproduced in full or partial, without the written approval of UL Japan, Inc.
2. The results in this report apply only to the sample tested.
3. This sample tested is in compliance with above regulation.
4. The test results in this report are traceable to the national or international standards.
5. This test report must not be used by the customer to claim product certification, approval, or endorsement by NVLAP, NIST, or any agency of the Federal Government.

**Date of test:** October 7, 2011

**Representative test engineer:**

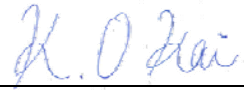
  
Katsunori Okai  
Engineer of WiSE Japan,  
UL Verification Service

**Approved by:**

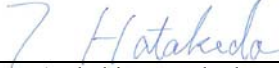
  
Takahiro Hatakeda  
Leader of WiSE Japan,  
UL Verification Service



NVLAP LAB CODE: 200572-0

This laboratory is accredited by the NVLAP LAB CODE 200572-0, U.S.A. The tests reported herein have been performed in accordance with its terms of accreditation.  
\*As for the range of Accreditation in NVLAP, you may refer to the WEB address,  
<http://www.ul.com/japan/jpn/pages/services/emc/about/mar1/index.jsp#nvlap>

**UL Japan, Inc.**

**Head Office EMC Lab.**

4383-326 Asama-cho, Ise-shi, Mie-ken 516-0021 JAPAN

Telephone : +81 596 24 8116

Facsimile : +81 596 24 8124

13-EM-F0429

<b>CONTENTS</b>	<b>PAGE</b>
<b>SECTION 1: Customer information.....</b>	<b>3</b>
<b>SECTION 2: Equipment under test (E.U.T.).....</b>	<b>3</b>
<b>SECTION 3: Scope of Report.....</b>	<b>5</b>
<b>SECTION 4: Test specification, procedures &amp; results.....</b>	<b>5</b>
<b>SECTION 5: Operation of E.U.T. during testing.....</b>	<b>10</b>
<b>SECTION 6: Channel Move Time, Channel Closing Transmission Time.....</b>	<b>16</b>
<b>SECTION 7: Non-Occupancy Period .....</b>	<b>18</b>
<b>APPENDIX 1: Test instruments .....</b>	<b>20</b>
<b>APPENDIX 2: Photographs of test setup .....</b>	<b>21</b>

## **SECTION 1: Customer information**

Company Name : SAMSUNG ELECTRONICS CO., LTD.  
Address : 416, MAETAN 3-DONG, YEONGTONG-GU SUWON-CITY,  
GYEONGGI-DO 443-742, SOUTH KOREA

## **SECTION 2: Equipment under test (E.U.T.)**

### **2.1 Identification of E.U.T.**

Type of Equipment : Cellular/PCS GSM/GPRS/EDGE Tablet with 802.11abgn, BT3.0  
Model No. : SC-02D  
Serial No. : Refer to Section 5, Clause 5.2  
Rating : DC4.0V  
Receipt Date of Sample : September 27, 2011  
Modification of EUT : No Modification by the test lab

### **2.2 Product Description**

#### **Radio Specification**

##### **Bluetooth**

Equipment Type	Transceiver
Frequency of Operation	2402-2480MHz
Type of Modulation	FHSS
Bandwidth & Channel spacing	1MHz & 1MHz
Antenna Type	PIFA
Antenna Gain	-0.63 dBi

##### **WLAN (IEEE802.11a/b/g/n-20)**

Equipment Type	Transceiver	
Frequency of Operation	2412-2462MHz	5180-5240MHz 5260-5320MHz 5500-5700MHz 5745-5825MHz
Type of Modulation	DSSS, OFDM	OFDM
Bandwidth & Channel spacing	20MHz & 5MHz	20MHz & 20MHz
Antenna Type	SEMI-PIFA	
Antenna Gain	2.4G: -0.4dBi	5G: -3.8dBi

##### **WLAN (IEEE802.11n-40)**

Equipment Type	Transceiver
Frequency of Operation	5190-5230MHz 5270-5310MHz 5510-5670MHz 5755-5795MHz
Type of Modulation	OFDM
Bandwidth & Channel spacing	40MHz & 40MHz
Antenna Type	SEMI-PIFA
Antenna Gain	-3.8dBi

**UL Japan, Inc.**

**Head Office EMC Lab.**

4383-326 Asama-cho, Ise-shi, Mie-ken 516-0021 JAPAN

Telephone : +81 596 24 8116

Facsimile : +81 596 24 8124

**GSM**

Equipment Type	Transceiver
Frequency of Operation	[Up Link] GSM850: 824 – 849MHz PCS: 1850 – 1910MHz [Down Link] GSM850: 869 – 894MHz PCS: 1930 – 1990MHz
Type of Modulation	GMSK , 8PSK
Antenna Type	PIFA
Antenna Gain	GSM850: -5.0dBi PCS: -1.5dBi

### **SECTION 3: Scope of Report**

This report only covers DFS requirement, as specified by the following referenced procedures.

### **SECTION 4: Test specification, procedures & results**

#### **4.1 Test Specification**

Test Specification	:	FCC Part 15 Subpart E: 2011, final revised on July 8, 2011 and effective August 8, 2011
Title	:	FCC 47CFR Part15 Radio Frequency Device Subpart E Unlicensed National Information Infrastructure Devices Section 15.407 General technical requirements
Test Specification	:	FCC 06-96 APPENDIX
Title	:	COMPLIANCE MEASUREMENT PROCEDURES FOR UNLICENSED- NATIONAL INFORMATION INFRASTRUCTURE DEVICES OPERATING IN THE 5250-5350 MHz AND 5470-5725MHz BANDS INCORPORATING DYNAMIC FREQUENCY SELECTION

## 4.2 Procedures and results

**Table 1: Applicability of DFS Requirements**

Requirement	Operating Mode	Test Procedures & Limits	Deviation	Results
	Client without Radar Detection			
U-NII Detection Bandwidth	Not required	FCC 06-96 Appendix 7.8.1	N/A	N/A
Channel Availability Check Time	Not required	FCC15.407 (h)	N/A	N/A
		FCC 06-96 Appendix 7.8.2.1		
		Appendix 7.8.2.2		
		Appendix 7.8.2.3		
RSS-210 A9.3				
Channel Move Time, Channel Closing Transmission Time	Yes	FCC15.407 (h)	N/A	Complied
		FCC 06-96 Appendix 7.8.3		
		RSS-210 A9.3		
Non-Occupancy period	Yes	FCC15.407 (h)	N/A	Complied
		FCC 06-96 Appendix 7.8.3		
		RSS-210 A9.3		
In-Service Monitoring	Not required	FCC15.407 (h)	N/A	N/A
		FCC 06-96 Appendix 7.8.4		
Overlapping Channel Tests	Not required	FCC15.407 (h)	N/A	N/A

**Table 2: DFS Detection Thresholds for Master Devices and Client Devices With Radar**

Maximum Transmit Power	Value (See Notes 1 and 2)
≥ 200 milliwatt	-64 dBm
< 200 milliwatt	-62 dBm
<p>Note 1: This is the level at the input of the receiver assuming a 0 dBi receive antenna.</p> <p>Note 2: Throughout these test procedures an additional 1 dB has been added to the amplitude of the test transmission waveforms to account for variations in measurement equipment. This will ensure that the test signal is at or above the detection threshold level to trigger a DFS response.</p>	

**Table 3 DFS Response Requirement Values**

<b>Parameter</b>	<b>Value</b>
Non-occupancy period	Minimum 30 minutes
Channel Availability Check Time	60 seconds
Channel Move Time	10 seconds See Note 1
Channel Closing Transmission Time	200 milliseconds + an aggregate of 60 milliseconds over remaining 10 second period. See Notes 1 and 2
U-NII Detection Bandwidth	Minimum 80% of the U-NII 99% transmission power bandwidth See Note 3
<p><b>Note 1:</b> The instant that the Channel Move Time and the Channel Closing Transmission Time begins is as follows:</p> <ul style="list-style-type: none"> <li>• For the Short Pulse Radar Test Signals this instant is the end of the <i>Burst</i>.</li> <li>• For the Frequency Hopping radar Test Signal, this instant is the end of the last radar <i>Burst</i> generated</li> <li>• For the Long Pulse Radar Test Signal this instant is the end of the 12 second period defining the <i>Radar Waveform</i>.</li> </ul> <p><b>Note 2:</b> The Channel Closing Transmission Time is comprised of 200 milliseconds starting at the beginning of the Channel Move Time plus any additional intermittent control signals required to facilitate a Channel move (an aggregate of 60 milliseconds) during the remainder of the 10 second period. The aggregate duration of control signal will not count quiet periods in between transmissions.</p> <p><b>Note 3:</b> During the U-NII Detection Bandwidth detection test, radar type 1 is used and for each frequency step the minimum percentage of detection is 90 percent. Measurements are performed with no data traffic.</p>	

**Table 4 Short Pulse Radar Test Waveform**

Radar Type	Pulse Width (μsec)	PRI (μsec)	Number of Pulses	Minimum Percentage of Successful Detection	Minimum Number of Trials
1	1	1428	18	60%	30
2	1-5	150-230	23-29	60%	30
3	6-10	200-500	16-18	60%	30
4	11-20	200-500	12-16	60%	30
Aggregate (Rader Types 1-4)				80%	120

**Table 5 Long Pulse Radar Test Waveform**

Radar Type	Pulse Width (μsec)	Chip Width (MHz)	PRI (μsec)	Number of Pulses per Burst	Number of Burst	Minimum Percentage of Successful Detection	Minimum Number of Trials
5	50-100	5-20	1000-2000	1-3	8-20	80%	30

**Table 6 Frequency Hopping Radar Test Waveform**

Radar Type	Pulse Width (μsec)	PRI (μsec)	Pulse per Hop (kHz)	Hopping Rate (kHz)	Hopping Sequence Length (msec)	Minimum Percentage of Successful Detection	Minimum Number of Trials
6	1	333	9	0.333	300	70%	30

### 4.3 Test Location

UL Japan, Inc. Head Office EMC Lab. \*NVLAP Lab. code: 200572-0  
4383-326 Asama-cho, Ise-shi, Mie-ken 516-0021 JAPAN  
Telephone : +81 596 24 8116 Facsimile : +81 596 24 8124

	FCC Registration Number	IC Registration Number	Width x Depth x Height (m)	Size of reference ground plane (m) / horizontal conducting plane	Other rooms
No.1 semi-anechoic chamber	313583	2973C-1	19.2 x 11.2 x 7.7m	7.0 x 6.0m	No.1 Power source room
No.2 semi-anechoic chamber	655103	2973C-2	7.5 x 5.8 x 5.2m	4.0 x 4.0m	-
No.3 semi-anechoic chamber	148738	2973C-3	12.0 x 8.5 x 5.9m	6.8 x 5.75m	No.3 Preparation room
No.3 shielded room	-	-	4.0 x 6.0 x 2.7m	N/A	-
No.4 semi-anechoic chamber	134570	2973C-4	12.0 x 8.5 x 5.9m	6.8 x 5.75m	No.4 Preparation room
No.4 shielded room	-	-	4.0 x 6.0 x 2.7m	N/A	-
No.5 semi-anechoic chamber	-	-	6.0 x 6.0 x 3.9m	6.0 x 6.0m	-
No.6 shielded room	-	-	4.0 x 4.5 x 2.7m	4.75 x 5.4 m	-
No.6 measurement room	-	-	4.75 x 5.4 x 3.0m	4.75 x 4.15 m	-
No.7 shielded room	-	-	4.7 x 7.5 x 2.7m	4.7 x 7.5m	-
No.8 measurement room	-	-	3.1 x 5.0 x 2.7m	N/A	-
No.9 measurement room	-	-	8.0 x 4.5 x 2.8m	2.0 x 2.0m	-
No.10 measurement room	-	-	2.6 x 2.8 x 2.5m	2.4 x 2.4m	-
No.11 measurement room	-	-	3.1 x 3.4 x 3.0m	2.4 x 3.4m	-

\* Size of vertical conducting plane (for Conducted Emission test) : 2.0 x 2.0m for No.1, No.2, No.3, and No.4 semi-anechoic chambers and No.3 and No.4 shielded rooms.

### 4.4 Test instruments of DFS and Test set up

Refer to APPENDIX.

## **SECTION 5: Operation of E.U.T. during testing**

### **5.1 Operating Modes**

The EUT, which is a Client Device without Radar detection capability, operates over the 5250–5350 MHz and 5470–5725 MHz bands.

Power level(EIRP) of the EUT[dBm]

5250-5350MHz Band*		5470-5725MHz Band*	
Output Power (Min)	Output Power(Max)	Output Power (Min)	Output Power(Max)
4.14	5.76	5.19	6.44

\*Refer to 32BE0278-HO-C, FCC Part 15E (FCC 15.407) report for other parts than DFS.

WLAN traffic is generated by performing a FTP file transfer. The file transfer from the master device to the client device consist of a 4.1Gbyte compressed data folder containing multiple copies of a 418 Mbyte file.

The EUT utilizes the 802.11a and 802.11n architecture, with a nominal channel bandwidth.

The FCC ID for the Master Device used with EUT for DFS testing is LDK102061.

The rated output power of the Master unit is >200mW(23dBm). Therefore the required interference threshold level is –64 dBm. After correction for antenna gain and procedural adjustments, the required conducted threshold at the antenna port is  $-64 + 1 + 3.5 = -59.5$  dBm (threshold level + additional 1dB + antenna gain).

It is impossible for users to change DFS control, because the DFS function is written on the firmware and users cannot access it.

The EUT was set by the software as follows:

Software name & version: HW: REV0.0, SW: N024.001

---

**UL Japan, Inc.**

**Head Office EMC Lab.**

4383-326 Asama-cho, Ise-shi, Mie-ken 516-0021 JAPAN

Telephone : +81 596 24 8116

Facsimile : +81 596 24 8124

## 5.2 Configuration and peripherals

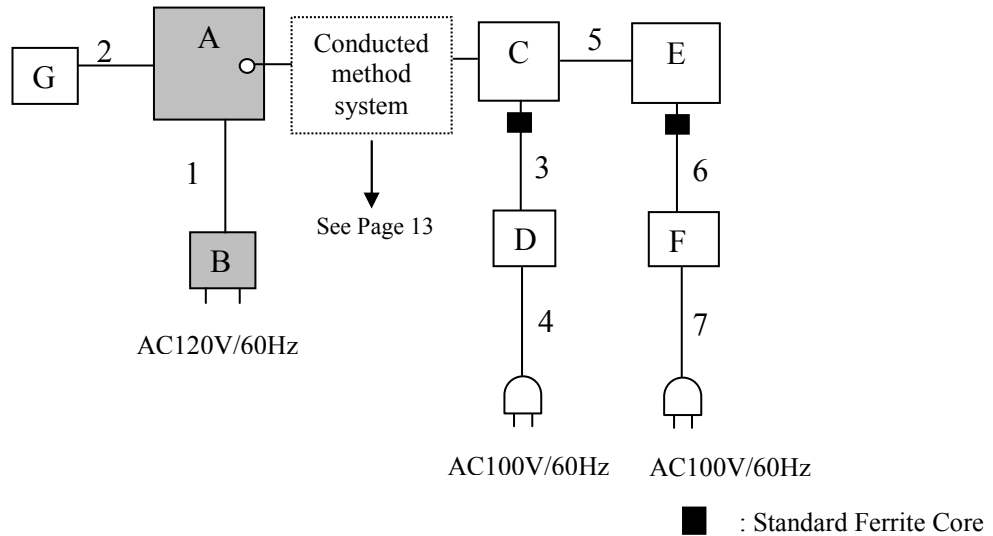

### Description of EUT and Support equipment

No.	Item	Model number	Serial number	Manufacturer	Remarks
A	Cellular/PCS GSM/GPRS/EDGE Tablet with 802.11abgn, BT3.0	SC-02D	R24B976664D	SAMSUNG	EUT
B	AC Adapter	SC02	-	SAMSUNG	EUT
C	Wireless LAN access point	AIR-AP1252AG-A-K9	FTX122391JU	Cisco Systems	-
D	AC Adapter	EADP-45BB	DTH11329086	DELTA ELECTRONICS,INC.,	-
E	Note PC	7661CB9	L3R2055	lenovo	-
F	AC adapter	92P1213	11S92P1213Z1ZBG K7AH11F	lenovo	-
G	Earphone	-	-	SAMSUNG	-

### List of cables used

No.	Name	Length (m)	Shield		Remarks
			Cable	Connector	
1	USB Cable	1.0	Shielded	Shielded	-
2	Earphone cable	1.2	Unshielded	Unshielded	-
3	DC Cable	1.8	Unshielded	Unshielded	
4	AC Cable	2.0	Unshielded	Unshielded	
5	LAN Cable	1.0	Unshielded	Unshielded	
6	DC Cable	1.8	Unshielded	Unshielded	
7	AC Cable	0.9	Unshielded	Unshielded	

**UL Japan, Inc.**

**Head Office EMC Lab.**

4383-326 Asama-cho, Ise-shi, Mie-ken 516-0021 JAPAN

Telephone : +81 596 24 8116

Facsimile : +81 596 24 8124

## 5.3 Test and Measurement System

### SYSTEM OVERVIEW

The measurement system is based on a conducted test method.

The software selects waveform parameters from within the bounds of the signal type on a random basis using uniform distribution. The short pulse types 2, 3, and 4, the long pulse type 5, and the frequency hopping type 6 parameters are randomized at run-time.

The signal monitoring equipment consists of a spectrum analyzer with the capacity to display 8001 bins on the horizontal axis. A time-domain resolution of 2 msec/bin is achievable with a 16 second sweep time, meeting the 10 seconds short pulse reporting criteria. The aggregate ON time is calculated by multiplying the number of bins above a threshold during a particular observation period by the dwell time per bin, with the analyzer set to peak detection. A time-domain resolution of 3 msec/bin is achievable with a 24 second sweep time, meeting the 22 second long pulse reporting criteria and allowing a minimum of 10 seconds after the end of the long pulse waveform.

### FREQUENCY HOPPING RADAR WAVEFORM GENERATING SUBSYSTEM

The first 100 frequencies are selected out of the hopping sequence of the randomized 475 hop frequencies. Only a *Burst* that has the frequency falling within the receiver bandwidth of the tested U-NII device is selected among those frequencies. (Frequency-domain simulation). The radar waveform generated at the start time of the selected *Burst* (Time-domain simulation) is download to the Signal Generator. If all of the randomly selected 100 frequencies do not fall within the receiver bandwidth of the U-NII device, the radar waveform is not used for the test.

**CONDUCTED METHODS SYSTEM BLOCK DIAGRAM**

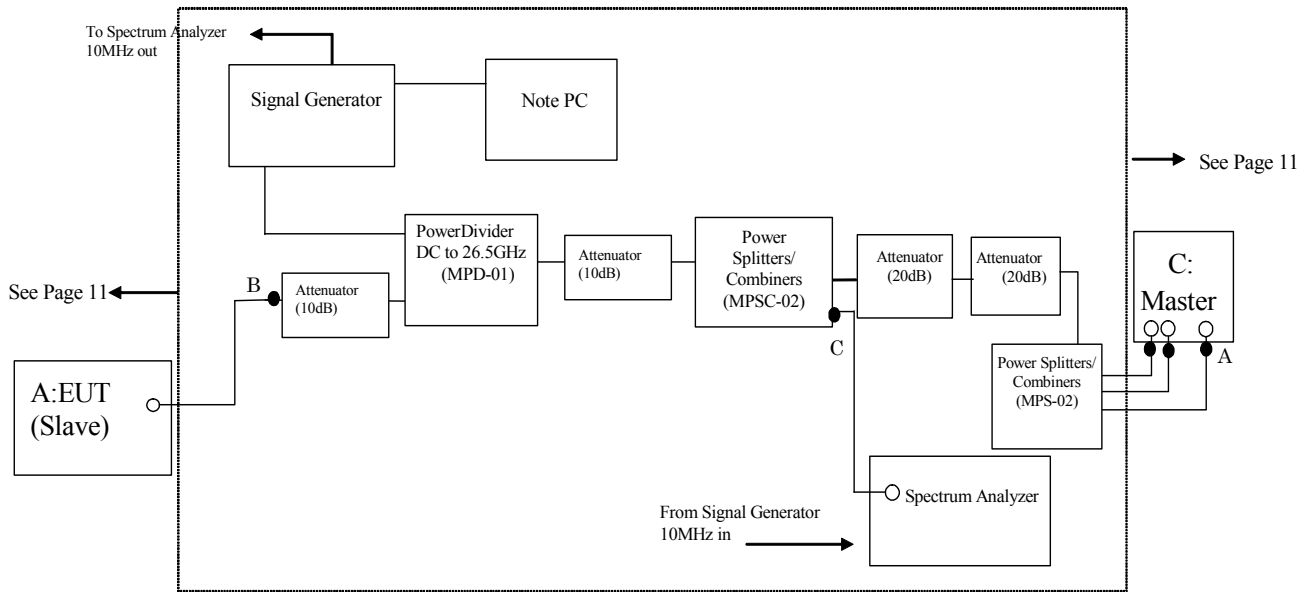

**MEASUREMENT SYSTEM FREQUENCY REFERENCE**

Lock the signal generator and the spectrum analyzer to the same reference sources as follows: Connect the 10MHz OUT on the signal generator to the 10MHz IN on the spectrum analyzer and set the spectrum analyzer 10MHz In to On.

**SYSTEM CALIBRATION**

**Step 1:** Set the system as shown in Figure 3 of FCC 06-96 7.2.1.

**Step 2:** Adjust each attenuator to fulfill the following three conditions:

- WLAN can be communicated, and
- Rader detection threshold level is higher than Client Device traffic level on the spectrum analyzer, and
- Master Device traffic level is not displayed on the spectrum analyzer.

**Step 3:** Terminate 50 ohm at B and C points, and connect the spectrum analyzer to the point A. (See the figure on page 13)

At the point A, adjust the signal generator and spectrum analyzer to the center frequency of the channel to be measured.

Download the applicable radar waveforms to the signal generator. Select the radar waveform, trigger a burst manually and measure the amplitude on the spectrum analyzer. Readjust the amplitude of the signal generator as required so that the peak level of the waveform is at a displayed level equal to the required or desired interference detection threshold.

Separate signal generator amplitude settings are determined as required for each radar type.

**Step 4:** Without changing any of the instrument settings, restore the system setting to Step 2 and adjust the Reference Level Offset of the spectrum analyzer to the level at Step 3.

By taking the above steps 1 to 4, the spectrum analyzer displays the level of the signal generator as received at the antenna ports of the Master Device.

See Clause 5.4 for Plots of Noise, Rader Waveforms, and WLAN signals.

**5.4 Plots of Noise, Rader Waveforms, and WLAN signals**

Plots of System Noise Floor

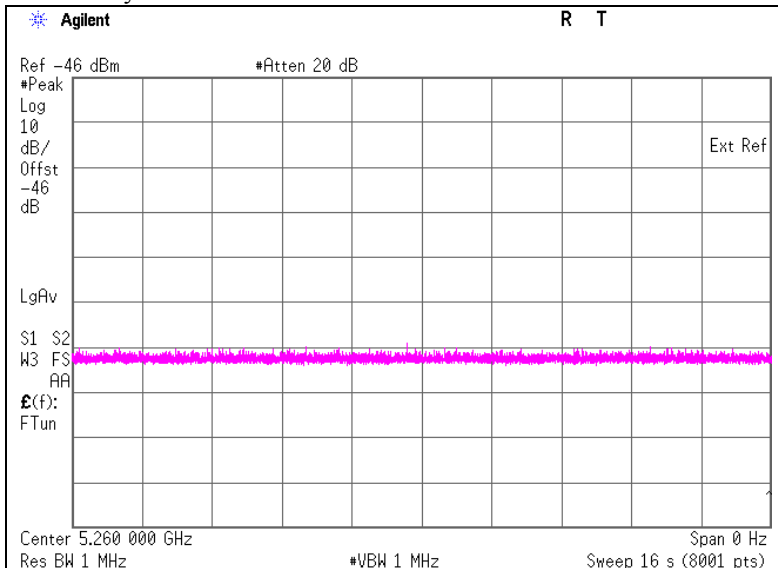

Plots of Radar Waveforms

Rader Type 1

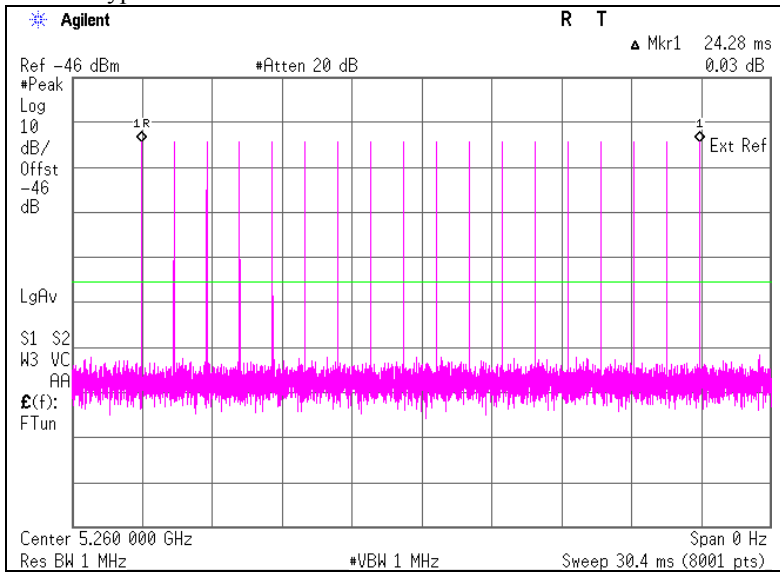

Plots of WLAN Traffic

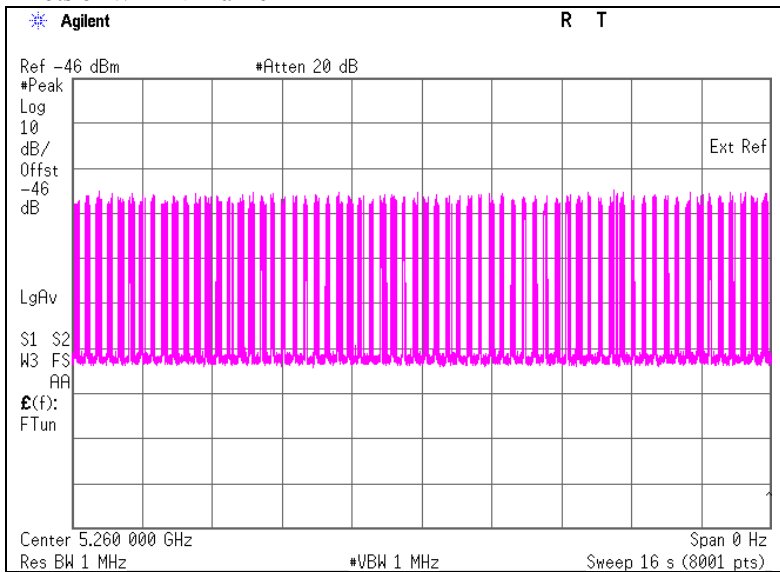

**UL Japan, Inc.**

**Head Office EMC Lab.**

4383-326 Asama-cho, Ise-shi, Mie-ken 516-0021 JAPAN

Telephone : +81 596 24 8116

Facsimile : +81 596 24 8124

## **SECTION 6: Channel Move Time, Channel Closing Transmission Time**

### **6.1 Operating environment**

Test place : No.7 shielded room  
Temperature : 26 deg.C.  
Humidity : 43 % RH

### **6.2 Test Procedure**

Transfer files from the Master Device to the Client Device on the tested channel during the entire period of the test. The Radar Waveform generator sends a Burst of pulses for one of the Short Pulse Radar Types 1-4 at levels defined , on the Operating Channel. An additional 1 dB is added to the radar test signal to ensure it is at or above the DFS Detection Threshold, accounting for equipment variations/errors.  
Observe the transmissions of the EUT at the end of the radar Burst on the Operating Channel for duration greater than 10 seconds.

### **6.3 Test data**

Test Item	Unit	Measurement Time	Limit	Results
Channel Move Time *1)	[sec]	2.052	10.000	Pass
Channel Closing Transmission Time *2)	[msec]	10	60	Pass

\*1) Channel Move Time is calculated as follows:

$$(\text{Channel Move Time}) = (\text{End of Transmission}) - (\text{End of Burst}) = 3.326 - 1.274$$

\*2) Channel Closing Transmission Time is calculated from (End of Burst + 200msec) to (End of Burst + 10sec )

$$(\text{Channel Closing Transmission Time}) = (\text{Number of analyzer bins showing transmission}) * (\text{dwell time per bin}) \\ = 5 * 2(\text{msec})$$

---

**UL Japan, Inc.**

**Head Office EMC Lab.**

4383-326 Asama-cho, Ise-shi, Mie-ken 516-0021 JAPAN

Telephone : +81 596 24 8116

Facsimile : +81 596 24 8124

Radar Type 1

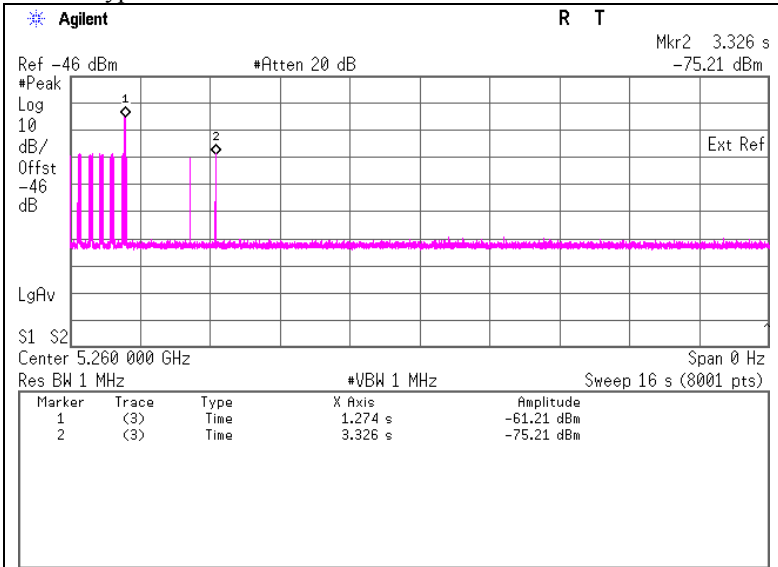

**Marker 1 : End of Burst : 1274 ms**  
**Marker 2 : End of Transmission : 3326 ms**

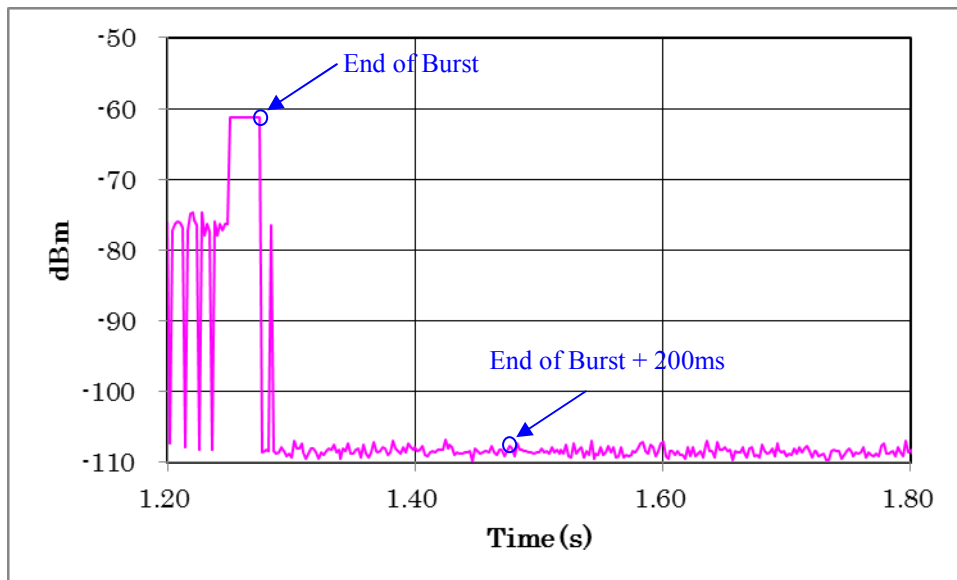

6.4 Test result

Test result: Pass

Date: October 7, 2011

Test engineer: Katsunori Okai

**UL Japan, Inc.**

**Head Office EMC Lab.**

4383-326 Asama-cho, Ise-shi, Mie-ken 516-0021 JAPAN

Telephone : +81 596 24 8116

Facsimile : +81 596 24 8124

## SECTION 7: Non-Occupancy Period

### 7.1 Operating environment

Test place : No.7 shielded room  
Temperature : 26 deg.C.  
Humidity : 43 % RH

### 7.2 Test Procedure

The following two tests are performed:

- 1). Transfer files from the Master Device to the Client Device on the tested channel during the entire period of the test. The Radar Waveform generator sends a Burst of pulses for one of the Radar Types 1-6 at levels defined on the Operating Channel. An additional 1 dB is added to the radar test signal to ensure it is at or above the DFS Detection Threshold, accounting for equipment variations/errors. Observe the transmissions of the EUT after the Channel Move Time on the Operating Channel for duration greater than 30 minutes.
- 2). Transfer files from the Master Device to the Client Device on the tested channel during the entire period of the test. Observe the transmissions of the EUT on the Operating Channel for duration greater than 30 minutes after the Master Device is shut off.

### 7.3 Test data

#### Non-Occupancy Period

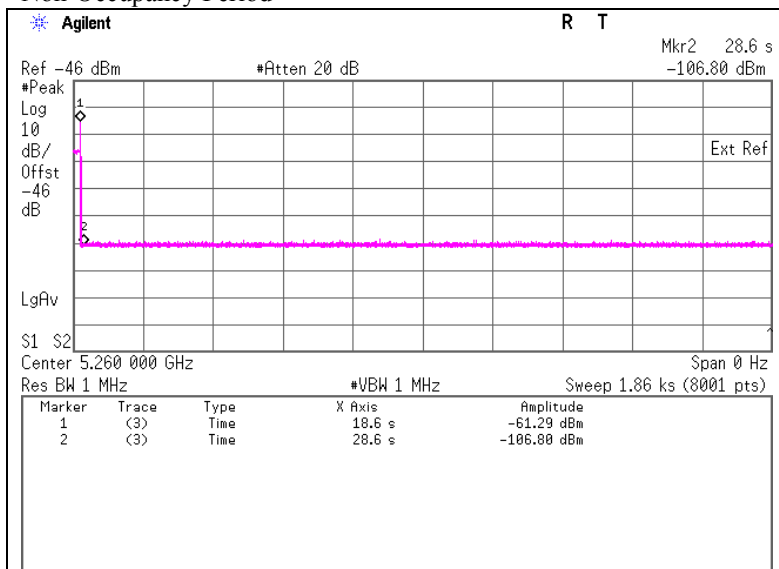

**Marker 1 : End of Burst : 18.6 sec**

**Marker 2 : End of Burst +10sec : 28.6 sec**

**UL Japan, Inc.**

**Head Office EMC Lab.**

4383-326 Asama-cho, Ise-shi, Mie-ken 516-0021 JAPAN

Telephone : +81 596 24 8116

Facsimile : +81 596 24 8124

2).Master is shut off

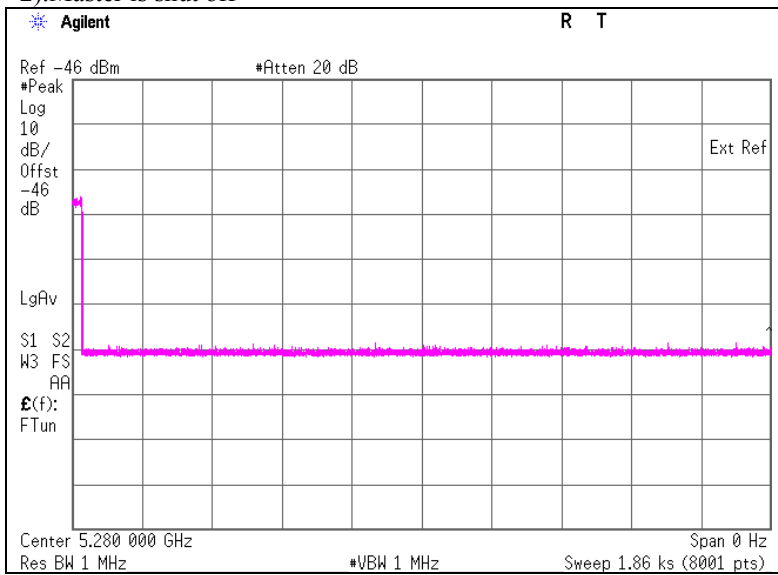

7.4 Test result

Test result: Pass

Date: October 7, 2011

Test engineer: Katsunori Okai

## **APPENDIX 1: Test instruments**

### **EMI Test Equipment**

Control No.	Instrument	Manufacturer	Model No	Serial No	Test Item	Calibration Date * Interval(month)
MOS-04	Digital Humidity Indicator	N.T	NT-1800	MOS04	DFS	2011/02/23 * 12
MSA-10	Spectrum Analyzer	Agilent	E4448A	MY46180655	DFS	2011/02/15 * 12
MSG-05	Signal Generator	Agilent	E4438C	MY45090353	DFS	2011/08/30 * 12
MCC-67	Microwave Cable 1G-40GHz	Suhner	SUCOFLEX102	28635/2	DFS	2011/04/22 * 12
MCC-115	Microwave Cable 1G-26.5GHz	Suhner	SUCOFLEX104	290211/4	DFS	2011/08/24 * 12
MCC-91	Microwave Cable 1G-40GHz	Schner	SUCOFLEX102	30812/2	DFS	2011/05/27 * 12
MCC-92	Microwave Cable 1G-40GHz	Schner	SUCOFLEX102	30813/2	DFS	2011/05/27 * 12
MCC-96	Microwave Cable 1G-40GHz	Schner	SUCOFLEX102	30817/2	DFS	2011/05/27 * 12
MCC-99	Microwave Cable 1G-40GHz	Schner	SUCOFLEX102	30820/2	DFS	2011/05/27 * 12
MCC-100	Microwave Cable 1G-40GHz	Suhner	SUCOFLEX102	30821/2	DFS	2011/05/27 * 12
MPD-01	Power Divider DC to 26.5GHz	Agilent	11636B	52258	DFS	2011/03/17 * 12
MPSC-02	Power Splitters/Combiners	Mini-Circuit	ZFSC-2-10G	0127	DFS	Pre Check
MPS-02	Power Splitter	Mini-Circuits	ZN4PD1-63-S+	001	DFS	2011/05/24 * 12
MAT-57	Attenuator(10dB)	Suhner	6810.19.A	-	DFS	Pre Check
MAT-58	Attenuator(10dB)	Suhner	6810.19.A	-	DFS	Pre Check
MAT-59	Attenuator(20dB)	Suhner	6820.19.A	-	DFS	Pre Check
MAT-60	Attenuator(20dB)	Suhner	6820.19.A	-	DFS	Pre Check
MTA-37	Terminator	-	50Ω SMA	-	DFS	Pre Check
MTA-38	Terminator	OMC	BL01-6118-00 (50Ω SMA)	-	DFS	Pre Check
COTS-MDFS-01	Signal Studio Software for DFS	Agilent	N7620A-101	5010-7739	DFS	-
COTS-MDFS-02	Radar Generating Software for DFS	Agilent	-	-	DFS	-

**The expiration date of the calibration is the end of the expired month.**

**All equipment is calibrated with valid calibrations. Each measurement data is traceable to the national or international standards.**

**As for some calibrations performed after the tested dates, those test equipment have been controlled by means of an unbroken chains of calibrations.**

**DFS: Dynamic Frequency Selection**

**UL Japan, Inc.**

**Head Office EMC Lab.**

**4383-326 Asama-cho, Ise-shi, Mie-ken 516-0021 JAPAN**

**Telephone : +81 596 24 8116**

**Facsimile : +81 596 24 8124**