



PCTEST ENGINEERING LABORATORY, INC.

6660-B Dobbin Road, Columbia, MD 21045 USA
Tel. +1.410.290.6652 / Fax +1.410.290.6554
<http://www.pctestlab.com>



SAR COMPLIANCE EVALUATION REPORT

Applicant Name:
Samsung Electronics, Co. Ltd.
18600 Broadwick St.
Rancho Dominguez, CA 90220
United States

Date of Testing:
05/02/11 - 05/04/11
Test Site/Location:
PCTEST Lab, Columbia, MD, USA
Test Report Serial No.:
0Y1104200782-R1.A3L

FCC ID: A3LSWDSC02C

APPLICANT: SAMSUNG ELECTRONICS, CO. LTD.

EUT Type: 850/1900 GSM/GPRS/EDGE Phone with Bluetooth and WLAN
Application Type: Certification
FCC Rule Part(s): CFR §2.1093; FCC/OET Bulletin 65 Supplement C [June 2001]
Model(s): SC-02C
Tx Frequency: 824.20 - 848.80 MHz (GSM 850) / 1850.20 - 1909.80 MHz (GSM 1900)
5260 - 5320 MHz (WLAN 802.11 a/n) / 5180 - 5240 MHz (WLAN 802.11 a/n)
5500 - 5700 MHz (WLAN 802.11 a/n) / 5745 - 5805 MHz (WLAN 802.11 a/n)
2412 - 2462 MHz (WLAN 802.11 b/g/n)
Conducted Power: 32.31 dBm GSM 850 / 29.72 dBm GSM 1900 / 11.48 dBm 5.2 GHz WLAN
12.25 dBm 5.3 GHz WLAN / 12.60 dBm 5.5 GHz WLAN
12.42 dBm 5.8 GHz WLAN / 17.22 dBm 2.4 GHz WLAN
Max. SAR Measurement: 0.24 W/kg GSM 850 Head SAR / 0.69 W/kg GSM 850 Body-Worn SAR
0.69 W/kg GSM 850 Hotspot Body SAR / 0.09 W/kg GSM 1900 Head SAR
0.69 W/kg GSM 1900 Body-Worn SAR / 0.69 W/kg GSM 1900 Hotspot Body SAR
0.02 W/kg 5.2 GHz WLAN Head SAR / 0.02 W/kg 5.2 GHz WLAN Body-Worn SAR
0.03 W/kg 5.3 GHz WLAN Head SAR / 0.02 W/kg 5.3 GHz WLAN Body-Worn SAR
0.23 W/kg 5.5 GHz WLAN Head SAR / 0.07 W/kg 5.5 GHz WLAN Body-Worn SAR
0.29 W/kg 5.8 GHz WLAN Head SAR / 0.07 W/kg 5.8 GHz WLAN Body-Worn SAR
0.10 W/kg 2.4 GHz WLAN Head SAR / 0.12 W/kg 2.4 GHz WLAN Body-Worn SAR
0.12 W/kg 2.4 GHz WLAN Hotspot Body SAR

Test Device SN: Pre-Production [S/N: FI-095-A, FI-095-B]

This wireless portable device has been shown to be capable of compliance for localized specific absorption rate (SAR) for uncontrolled environment/general population exposure limits specified in ANSI/IEEE C95.1-1992 and has been tested in accordance with the measurement procedures specified in FCC/OET Bulletin 65 Supplement C (2001), IEEE 1528-2003 and in applicable Industry Canada Radio Standards Specifications (RSS); for North American frequency bands only.

Note: This revised Test Report (S/N: 0Y1104200782-R1.A3L) supersedes and replaces the previously issued test report on the same subject EUT for the same type of testing as indicated. Please discard or destroy the previously issued test report(s) and dispose of it accordingly.

I attest to the accuracy of data. All measurements reported herein were performed by me or were made under my supervision and are correct to the best of my knowledge and belief. I assume full responsibility for the completeness of these measurements and vouch for the qualifications of all persons taking them. Test results reported herein relate only to the item(s) tested.

PCTEST certifies that no party to this application has been subject to a denial of Federal benefits that includes FCC benefits pursuant to Section 5301 of the Anti-Drug Abuse Act of 1988, 21 U.S.C. 862.



Randy Ortanez
President



FCC ID: A3LSWDSC02C		SAR COMPLIANCE REPORT		Reviewed by: Quality Manager
Filename: 0Y1104200782-R1.A3L	Test Dates: 05/02/11 - 05/04/11	EUT Type: 850/1900 GSM/GPRS/EDGE Phone with Bluetooth and WLAN	Page 1 of 45	

T A B L E O F C O N T E N T S

1	INTRODUCTION	3
2	TEST SITE LOCATION	4
3	SAR MEASUREMENT SETUP	5
4	DASY E-FIELD PROBE SYSTEM	7
5	PROBE CALIBRATION PROCESS	8
6	PHANTOM AND EQUIVALENT TISSUES.....	9
7	DOSIMETRIC ASSESSMENT & PHANTOM SPECS.....	10
8	DEFINITION OF REFERENCE POINTS	11
9	TEST CONFIGURATION POSITIONS	12
10	FCC RF EXPOSURE LIMITS.....	15
11	FCC 3G MEASUREMENT PROCEDURES.....	16
12	SAR TESTING WITH IEEE 802.11 TRANSMITTERS.....	17
13	PERSONAL WIRELESS ROUTER CONSIDERATIONS	20
14	SYSTEM VERIFICATION.....	22
15	SAR DATA SUMMARY	25
16	FCC MULTI-TX AND ANTENNA SAR CONSIDERATIONS.....	32
17	EQUIPMENT LIST.....	34
18	MEASUREMENT UNCERTAINTIES	35
19	CONCLUSION.....	37
20	REFERENCES	38
21	SAR TEST SETUP PHOTOGRAPHS.....	40

FCC ID: A3LSWDSC02C		SAR COMPLIANCE REPORT		Reviewed by: Quality Manager
Filename: 0Y1104200782-R1.A3L	Test Dates: 05/02/11 - 05/04/11	EUT Type: 850/1900 GSM/GPRS/EDGE Phone with Bluetooth and WLAN		Page 2 of 45

1 INTRODUCTION

The FCC has adopted the guidelines for evaluating the environmental effects of radio frequency (RF) radiation in ET Docket 93-62 on Aug. 6, 1996 to protect the public and workers from the potential hazards of RF emissions due to FCC-regulated portable devices. [1]

The safety limits used for the environmental evaluation measurements are based on the criteria published by the American National Standards Institute (ANSI) for localized specific absorption rate (SAR) in IEEE/ANSI C95.1-1992 Standard for Safety Levels with Respect to Human Exposure to Radio Frequency Electromagnetic Fields, 3 kHz to 300 GHz [3] and Health Canada RF Exposure Guidelines Safety Code 6 [24]. The measurement procedure described in IEEE/ANSI C95.3-2002 Recommended Practice for the Measurement of Potentially Hazardous Electromagnetic Fields - RF and Microwave [4] is used for guidance in measuring the Specific Absorption Rate (SAR) due to the RF radiation exposure from the Equipment Under Test (EUT). These criteria for SAR evaluation are similar to those recommended by the International Committee for Non-Ionizing Radiation Protection (ICNIRP) in Biological Effects and Exposure Criteria for Radiofrequency Electromagnetic Fields,” Report No. Vol 74. SAR is a measure of the rate of energy absorption due to exposure to an RF transmitting source. SAR values have been related to threshold levels for potential biological hazards.

1.1 SAR Definition

Specific Absorption Rate is defined as the time derivative (rate) of the incremental energy (dU) absorbed by (dissipated in) an incremental mass (dm) contained in a volume element (dV) of a given density (ρ). It is also defined as the rate of RF energy absorption per unit mass at a point in an absorbing body (see Fig. 1-1).

$$SAR = \frac{d}{dt} \left(\frac{dU}{dm} \right) = \frac{d}{dt} \left(\frac{dU}{\rho dV} \right)$$

Figure 1-1
SAR Mathematical Equation



SAR is expressed in units of Watts per Kilogram (W/kg).

$$SAR = \frac{\sigma \cdot E^2}{\rho}$$

where:

- σ = conductivity of the tissue-simulating material (S/m)
- ρ = mass density of the tissue-simulating material (kg/m³)
- E = Total RMS electric field strength (V/m)

NOTE: The primary factors that control rate of energy absorption were found to be the wavelength of the incident field in relation to the dimensions and geometry of the irradiated organism, the orientation of the organism in relation to the polarity of field vectors, the presence of reflecting surfaces, and whether conductive contact is made by the organism with a ground plane.[6]

FCC ID: A3LSWDSC02C	 PCTEST ENGINEERING LABORATORY, INC.	SAR COMPLIANCE REPORT		Reviewed by: Quality Manager
Filename: 0Y1104200782-R1.A3L	Test Dates: 05/02/11 - 05/04/11	EUT Type: 850/1900 GSM/GPRS/EDGE Phone with Bluetooth and WLAN		Page 3 of 45

2 TEST SITE LOCATION

2.1 INTRODUCTION

The map at the right shows the location of the PCTEST LABORATORY in Columbia, Maryland. It is in proximity to the FCC Laboratory, the Baltimore-Washington International (BWI) airport, the city of Baltimore and Washington, DC.

These measurement tests were conducted at the PCTEST Engineering Laboratory, Inc. facility in New Concept Business Park, Guilford Industrial Park, Columbia, Maryland. The site address is 6660-B Dobbin Road, Columbia, MD 21045. The test site is one of the highest points in the Columbia area with an elevation of 390 feet above mean sea level. The site coordinates are 39° 11'15" N latitude and 76° 49' 38" W longitude. The facility is 1.5 miles north of the FCC laboratory, and the ambient signal and ambient signal strength are approximately equal to those of the FCC laboratory. There are no FM or TV transmitters within 15 miles of the site. The detailed description of the measurement facility was found to be in compliance with the requirements of § 2.948 according to ANSI C63.4 on January 27, 2006 and Industry Canada.

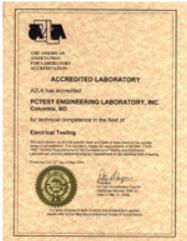

Figure 2-1



Map of the Greater Baltimore and Metropolitan Washington, D.C. area

2.2 Test Facility / Accreditations:

Measurements were performed at an independent accredited PCTEST Engineering Lab located in Columbia, MD 21045, U.S.A.



- PCTEST Lab is accredited to ISO 17025-2005 by the American Association for Laboratory Accreditation (A2LA) in Specific Absorption Rate (SAR) testing, Hearing-Aid Compatibility (HAC), Battery Safety, CTIA Test Plans, and wireless testing for FCC and Industry Canada Rules.
- PCTEST Lab is accredited to ISO 17025 by U.S. National Institute of Standards and Technology (NIST) under the National Voluntary Laboratory Accreditation Program (NVLAP Lab code: 100431-0) in EMC, FCC and Telecommunications.
- PCTEST facility is an FCC registered (PCTEST Reg. No. 90864) test facility with the site description report on file and has met all the requirements specified in Section 2.948 of the FCC Rules and Industry Canada (IC-2451).
- PCTEST Lab is a recognized U.S. Conformity Assessment Body (CAB) in EMC and R&TTE (n.b. 0982) under the U.S.-EU Mutual Recognition Agreement (MRA).
- PCTEST TCB is a Telecommunication Certification Body (TCB) accredited to ISO/IEC Guide 65 by the American National Standards Institute (ANSI) in all scopes of FCC Rules and all Industry Canada Standards (RSS).
- PCTEST facility is an IC registered (IC-2451) test laboratory with the site description on file at Industry Canada.
- PCTEST is a CTIA Authorized Test Laboratory (CATL) for AMPS and CDMA, and EvDO mobile phones.
- PCTEST is a CTIA Authorized Test Laboratory (CATL) for Over-the-Air (OTA) Antenna Performance testing for AMPS, CDMA, GSM, GPRS, EGPRS, UMTS (W-CDMA), CDMA 1xEVDO Data, CDMA 1xRTT Data

FCC ID: A3LSWDSC02C		SAR COMPLIANCE REPORT		Reviewed by: Quality Manager
Filename: 0Y1104200782-R1.A3L	Test Dates: 05/02/11 - 05/04/11	EUT Type: 850/1900 GSM/GPRS/EDGE Phone with Bluetooth and WLAN	Page 4 of 45	

3 SAR MEASUREMENT SETUP

3.1 Robotic System

Measurements are performed using the DASY4 automated dosimetric assessment system. The DASY4 is made by Schmid & Partner Engineering AG (SPEAG) in Zurich, Switzerland and consists of a high precision robotics system (Staubli), robot controller, desktop computer, near-field probe, probe alignment sensor, and the SAM phantom containing the head or body equivalent material. The robot is a six-axis industrial robot, performing precise movements to position the probe to the location (points) of maximum electromagnetic field (EMF) (see Figure 3-1).

3.2 System Hardware

A cell controller system contains the power supply, robot controller, teach pendant (Joystick), and a remote control used to drive the robot motors. The PC consists of the SAR Measurement Software DASY4, A/D interface card, monitor, mouse, and keyboard. The Staubli Robot is connected to the cell controller to allow software manipulation of the robot. A data acquisition electronic (DAE) circuit that performs the signal amplification, signal multiplexing, A/D conversion, offset measurements, mechanical surface detection, collision detection, etc. is connected to the Electro-optical coupler (EOC). The EOC performs the conversion from the optical into digital electric signal from the DAE and transfers data to the PC card.

3.3 System Electronics

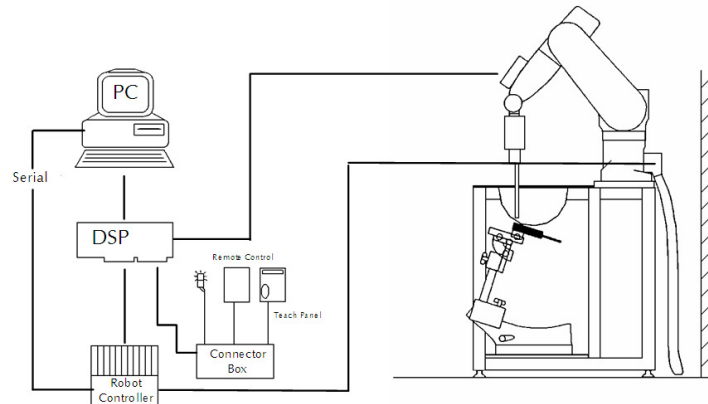



Figure 3-1
SAR Measurement System Setup

The DAE consists of a highly sensitive electrometer-grade auto-zeroing preamplifier, a channel and gain-switching multiplexer, a fast 16 bit AD-converter and a command decoder and control logic unit. Transmission to the PC-card is accomplished through an optical downlink for data and status information and an optical uplink for commands and clock lines. The mechanical probe mounting device includes two different sensor systems for frontal and sidewise probe contacts. They are also used for mechanical surface detection and probe collision detection. The robot uses its own controller with a built in VME-bus computer.

FCC ID: A3LSWDSC02C	 PCTEST ENGINEERING LABORATORY, INC.	SAR COMPLIANCE REPORT		Reviewed by: Quality Manager
Filename: 0Y1104200782-R1.A3L	Test Dates: 05/02/11 - 05/04/11	EUT Type: 850/1900 GSM/GPRS/EDGE Phone with Bluetooth and WLAN		Page 5 of 45

3.4 Automated Test System Specifications

Test Software: SPEAG DASY4 version 4.7 Measurement Software
 Robot: Stäubli Unimation Corp. Robot RX60L
 Repeatability: 0.02 mm
 No. of Axes: 6

Data Acquisition Electronic System (DAE)

Data Converter

Features: Signal Amplifier, multiplexer, A/D converter & control logic
 Software: SEMCAD software
 Connecting Lines: Optical Downlink for data and status info
 Optical upload for commands and clock

PC Interface Card



Function: Link to DAE
 16-bit A/D converter for surface detection system
 Two Serial & Ethernet link to robotics
 Direct emergency stop output for robot

Phantom

Type: SAM Twin Phantom (V4.0)
 Shell Material: Composite
 Thickness: 2.0 ± 0.2 mm



Figure 3-2
SAR Measurement System

FCC ID: A3LSWDSC02C		SAR COMPLIANCE REPORT		Reviewed by: Quality Manager
Filename: 0Y1104200782-R1.A3L	Test Dates: 05/02/11 - 05/04/11	EUT Type: 850/1900 GSM/GPRS/EDGE Phone with Bluetooth and WLAN	Page 6 of 45	

4

DASY E-FIELD PROBE SYSTEM

4.1 Probe Measurement System



**Figure 4-1
SAR System**

The SAR measurements were conducted with the dosimetric probe designed in the classical triangular configuration (see Figure 4-3) and optimized for dosimetric evaluation [9]. The probe is constructed using the thick film technique; with printed resistive lines on ceramic substrates. The probe is equipped with an optical multi-fiber line ending at the front of the probe tip. It is connected to the EOC box on the robot arm and provides an automatic detection of the phantom surface. Half of the fibers are connected to a pulsed infrared transmitter, the other half to a synchronized receiver. As the probe approaches the surface, the reflection from the surface produces a coupling from the transmitting to the receiving fibers. This reflection increases first during the approach, reaches maximum and then decreases. If the probe is flatly touching the surface, the coupling is zero. The distance of the coupling maximum to the surface is independent of the surface reflectivity and largely independent of the surface to probe angle. The DASY4 software reads the reflection during a software approach and looks for the

maximum using a 2nd order curve fitting (see Figure 5-1). The approach is stopped at reaching the maximum.

4.2 Probe Specifications



Model(s):	ES3DV2, ES3DV3, EX3DV4
Frequency Range:	10 MHz – 6.0 GHz (EX3DV4) 10 MHz – 4 GHz (ES3DV3)
Calibration:	In head and body simulating tissue at Frequencies from 300 up to 6000MHz
Linearity:	± 0.2 dB (30 MHz to 6 GHz) for EX3DV4 ± 0.2 dB (30 MHz to 4 GHz) for ES3DV3
Dynamic Range:	10 mW/kg – 100 W/kg
Probe Length:	330 mm
Probe Tip Length:	20 mm
Body Diameter:	12 mm
Tip Diameter:	2.5 mm (3.9mm for ES3DV3)
Tip-Center:	1 mm (2.0 mm for ES3DV3)
Application:	SAR Dosimetry Testing Compliance tests of mobile phones Dosimetry in strong gradient fields



**Figure 4-2
Near-Field Probe**



**Figure 4-3
Triangular Probe
Configuration**

FCC ID: A3LSWDSC02C	 PCTEST ENGINEERING LABORATORY, INC.	SAR COMPLIANCE REPORT		Reviewed by: Quality Manager
Filename: 0Y1104200782-R1.A3L	Test Dates: 05/02/11 - 05/04/11	EUT Type: 850/1900 GSM/GPRS/EDGE Phone with Bluetooth and WLAN		Page 7 of 45

5 PROBE CALIBRATION PROCESS

5.1 Dosimetric Assessment Procedure

Each E-Probe/Probe Amplifier combination has unique calibration parameters. A TEM cell calibration procedure is conducted to determine the proper amplifier settings to enter in the probe parameters. The amplifier settings are determined for a given frequency by subjecting the probe to a known E-field density (1 mW/cm²) using an RF Signal generator, TEM cell, and RF Power Meter.

5.2 Free Space Assessment

The free space E-field from amplified probe outputs is determined in a test chamber. This calibration can be performed in a TEM cell if the frequency is below 1 GHz and in a waveguide or other methodologies above 1 GHz for free space. For the free space calibration, the probe is placed in the volumetric center of the cavity and at the proper orientation with the field. The probe is rotated 360 degrees until the three channels show the maximum reading. The power density readings equates to 1 mW/cm².

5.3 Temperature Assessment

E-field temperature correlation calibration is performed in a flat phantom filled with the appropriate simulated head tissue. The E-field in the medium correlates with the temperature rise in the dielectric medium. For temperature correlation calibration a RF transparent thermistor-based temperature probe is used in conjunction with the E-field probe.

$$SAR = C \frac{\Delta T}{\Delta t}$$

where:

- Δt = exposure time (30 seconds),
- C = heat capacity of tissue (brain or muscle),
- ΔT = temperature increase due to RF exposure.

$$SAR = \frac{|E|^2 \cdot \sigma}{\rho}$$

where:

- σ = simulated tissue conductivity,
- ρ = Tissue density (1.25 g/cm³ for brain tissue)

SAR is proportional to $\Delta T/\Delta t$, the initial rate of tissue heating, before thermal diffusion takes place. The electric field in the simulated tissue can be used to estimate SAR by equating the thermally derived SAR to that with the E- field component.

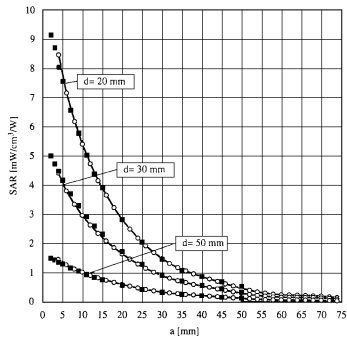

Figure 5-1 E-Field and Temperature measurements at 900MHz [9]

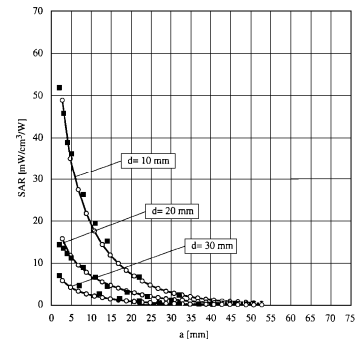



Figure 5-2 E-Field and temperature measurements at 1.9GHz [9]

FCC ID: A3LSWDSC02C	 PCTEST ENGINEERING LABORATORY, INC.	SAR COMPLIANCE REPORT		Reviewed by: Quality Manager
Filename: 0Y1104200782-R1.A3L	Test Dates: 05/02/11 - 05/04/11	EUT Type: 850/1900 GSM/GPRS/EDGE Phone with Bluetooth and WLAN		Page 8 of 45

6

PHANTOM AND EQUIVALENT TISSUES

6.1 SAM Phantoms



**Figure 6-1
SAM Phantoms**

The SAM Twin Phantom V4.0 is constructed of a fiberglass shell integrated in a table. The shape of the shell is based on data from an anatomical study designed to represent the 90th percentile of the population [12][13]. The phantom enables the dosimetric evaluation of SAR for both left and right handed handset usage, as well as body-worn usage using the flat phantom region. Reference markings on the Phantom allow the complete setup of all predefined phantom positions and measurement grids by manually teaching three points in the robot. The shell phantom has a 2mm shell thickness (except the ear region where shell thickness increases to 6 mm).

6.2 Tissue Simulating Mixture Characterization

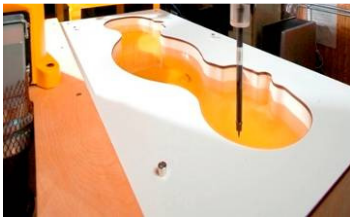



**Figure 6-2
SAM Phantom with
Simulating Tissue**

The mixture is characterized to obtain proper dielectric constant (permittivity) and conductivity of the tissue of interest. The tissue dielectric parameters recommended in IEEE 1528 and IEC 62209 have been used as targets for the compositions, and are to match within 5%, per the FCC recommendations.

**Table 6-1
Composition of the Tissue Equivalent Matter**

Frequency (MHz)	835	835	1900	1900	2450	2450	5200-5800	5200-5800
Tissue	Head	Body	Head	Body	Head	Body	Head	Body
Ingredients (% by weight)								
Bactericide	0.1	0.1						
DGBE			44.92	29.44	7.99	26.7		
HEC	1	1						
NaCl	1.45	0.94	0.18	0.39	0.16	0.1		
Sucrose	57	44.9						
Triton X-100					19.97		17.24	10.67
Diethyleneglycol monohexylether							17.24	10.67
Water	40.45	53.06	54.9	70.17	71.88	73.2	65.52	78.66

FCC ID: A3LSWDSC02C	 PCTEST ENGINEERING LABORATORY, INC.	SAR COMPLIANCE REPORT		Reviewed by: Quality Manager
Filename: 0Y1104200782-R1.A3L	Test Dates: 05/02/11 - 05/04/11	EUT Type: 850/1900 GSM/GPRS/EDGE Phone with Bluetooth and WLAN		Page 9 of 45

7 DOSIMETRIC ASSESSMENT & PHANTOM SPECS

7.1 Measurement Procedure

The evaluation was performed using the following procedure:

1. The SAR distribution at the exposed side of the head was measured at a distance no greater than 5.0 mm from the inner surface of the shell. The area covered the entire dimension of the head and the horizontal grid spacing was 15mm x 15mm.
2. The point SAR measurement was taken at the maximum SAR region determined from Step 1 to enable the monitoring of SAR fluctuations/drifts during testing the 1 gram cube. This fixed point was measured and used as a reference value.
3. Based on the area scan data, the area of the maximum absorption was determined by spline interpolation. Around this point, a volume of 32mm x 32mm x 30mm (fine resolution volume scan, zoom scan) was assessed by measuring 5 x 5 x 7 points. On this basis of this data set, the spatial peak SAR value was evaluated with the following procedure (see references or the DASY manual for more details):
 - a. The data was extrapolated to the surface of the outer-shell of the phantom. The combined distance extrapolated was the combined distance from the center of the dipoles 2.7mm away from the tip of the probe housing plus the 1.2 mm distance between the surface and the lowest measuring point. The extrapolation was based on a least-squares algorithm. A polynomial of the fourth order was calculated through the points in the z-axis (normal to the phantom shell).
 - b. After the maximum interpolated values were calculated between the points in the cube, the SAR was averaged over the spatial volume (1g or 10g) using a 3D-Spline interpolation algorithm. The 3D-spline is composed of three one-dimensional splines with the "Not a knot" condition (in x, y, and z directions). The volume was then integrated with the trapezoidal algorithm. One thousand points (10 x 10 x 10) were obtained through interpolation, in order to calculate the averaged SAR.
 - c. All neighboring volumes were evaluated until no neighboring volume with a higher average value was found.
4. The SAR reference value, at the same location as step 2, was re-measured after the zoom scan was complete. If the value deviated by more than 5%, the evaluation was repeated.
5. For 5 GHz testing finer resolution zoom scans were performed as specified by FCC SAR Measurement Requirements for 3 – 6 GHz, KDB pub 865664. The 5 GHz zoom scan requires a minimum volume of 24mm x 24mm x 20mm and 7 x 7 x 11 points.

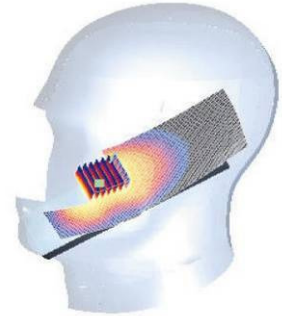



Figure 7-1
Sample SAR Area Scan

7.2 Specific Anthropomorphic Mannequin (SAM) Specifications

The phantom for handset SAR assessment testing is a low-loss dielectric shell, with shape and dimensions derived from the anthropometric data of the 90th percentile adult male head dimensions as tabulated by the US Army. The SAM Twin Phantom shell is bisected along the mid-sagittal plane into right and left halves (see Figure 7-2). The perimeter sidewalls of each phantom halves are extended to allow filling with liquid to a depth that is sufficient to minimize reflections from the upper surface. The liquid depth is maintained at a minimum depth of 15 cm.



Figure 7-2
SAM Twin Phantom Shell

FCC ID: A3LSWDSC02C	 PCTEST ENGINEERING LABORATORY, INC.	SAR COMPLIANCE REPORT		Reviewed by: Quality Manager
Filename: 0Y1104200782-R1.A3L	Test Dates: 05/02/11 - 05/04/11	EUT Type: 850/1900 GSM/GPRS/EDGE Phone with Bluetooth and WLAN		Page 10 of 45

8

DEFINITION OF REFERENCE POINTS

8.1 EAR REFERENCE POINT

Figure 8-1 shows the front, back and side views of the SAM Twin Phantom. The point “M” is the reference point for the center of the mouth, “LE” is the left ear reference point (ERP), and “RE” is the right ERP. The ERP is 15mm posterior to the entrance to the ear canal (EEC) along the B-M line (Back-Mouth), as shown in Figure 8-1. The plane passing through the two ear canals and M is defined as the Reference Plane. The line N-F (Neck-Front) is perpendicular to the reference plane and passing through the RE (or LE) is called the Reference Pivoting Line (see Figure 8-2). Line B-M is perpendicular to the N-F line. Both N-F and B-M lines are marked on the external phantom shell to facilitate handset positioning [5].

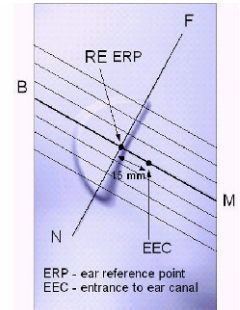

Figure 8-1
Close-Up Side view of ERP

8.2 HANDSET REFERENCE POINTS

Two imaginary lines on the handset were established: the vertical centerline and the horizontal line. The test device was placed in a normal operating position with the “test device reference point” located along the “vertical centerline” on the front of the device aligned to the “ear reference point” (See Figure 8-3). The “test device reference point” was then located at the same level as the center of the ear reference point. The test device was positioned so that the “vertical centerline” was bisecting the front surface of the handset at its top and bottom edges, positioning the “ear reference point” on the outer surface of the both the left and right head phantoms on the ear reference point.

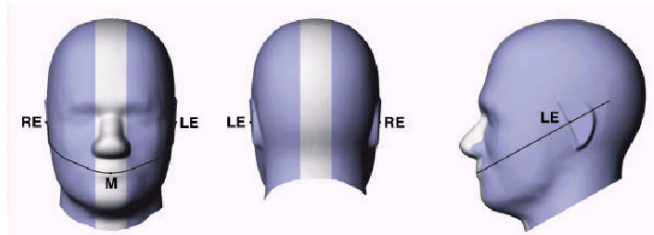

Figure 8-2
Front, back and side view of SAM Twin Phantom

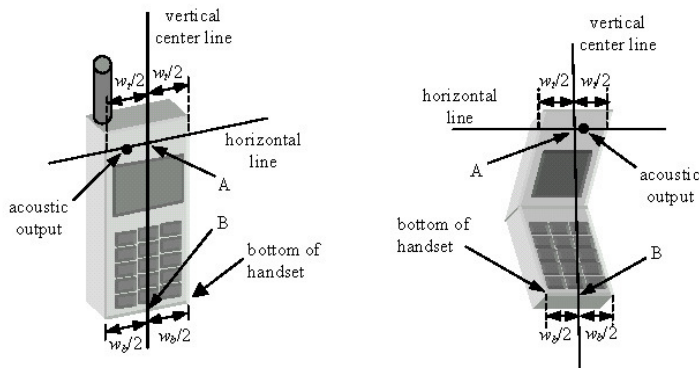

Figure 8-3
Handset Vertical Center & Horizontal Line Reference Points

FCC ID: A3LSWDSC02C	PCTEST ENGINEERING LABORATORY, INC.	SAR COMPLIANCE REPORT		Reviewed by: Quality Manager
Filename: 0Y1104200782-R1.A3L	Test Dates: 05/02/11 - 05/04/11	EUT Type: 850/1900 GSM/GPRS/EDGE Phone with Bluetooth and WLAN		Page 11 of 45

9 TEST CONFIGURATION POSITIONS

9.1 Device Holder

The DASY device holder has been made out of low-loss POM material having the following dielectric parameters: relative permittivity $\epsilon = 3$ and loss tangent $\delta = 0.02$.

9.2 Positioning for Cheek/Touch

1. The test device was positioned with the handset close to the surface of the phantom such that point A is on the (virtual) extension of the line passing through points RE and LE on the phantom (see Figure 9-1), such that the plane defined by the vertical center line and the horizontal line of the phone is approximately parallel to the sagittal plane of the phantom.

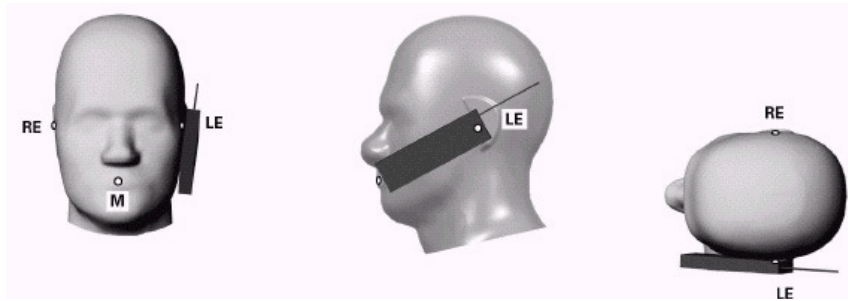



Figure 9-1 Front, Side and Top View of Cheek/Touch Position

2. The handset was translated towards the phantom along the line passing through RE & LE until the handset touches the ear.
3. While maintaining the handset in this plane, the handset was rotated around the LE-RE line until the vertical centerline was in the plane normal to MB-NF including the line MB (reference plane).
4. The phone was then rotated around the vertical centerline until the phone (horizontal line) was symmetrical with respect to the line NF.
5. While maintaining the vertical centerline in the reference plane, keeping point A on the line passing through RE and LE, and maintaining the phone contact with the ear, the handset was rotated about the line NF until any point on the handset made contact with a phantom point below the ear (cheek) (See Figure 9-2).

9.3 Positioning for Ear / 15° Tilt

With the test device aligned in the “Cheek/Touch Position”:

1. While maintaining the orientation of the phone, the phone was retracted parallel to the reference plane far enough to enable a rotation of the phone by 15 degree.
2. The phone was then rotated around the horizontal line by 15 degree.
3. While maintaining the orientation of the phone, the phone was moved parallel to the reference plane until any part of the phone touches the head. (In this position, point A was located on the line RE-LE). The tilted position is obtained when the contact is on the pinna. If the contact was at any location other than the pinna, the angle of the phone would then be reduced. The tilted position was obtained when any part of the phone was in contact of the ear as well as a second part of the phone was in contact with the head (see Figure 9-2).

FCC ID: A3LSWDSC02C		SAR COMPLIANCE REPORT		Reviewed by: Quality Manager
Filename: 0Y1104200782-R1.A3L	Test Dates: 05/02/11 - 05/04/11	EUT Type: 850/1900 GSM/GPRS/EDGE Phone with Bluetooth and WLAN		Page 12 of 45

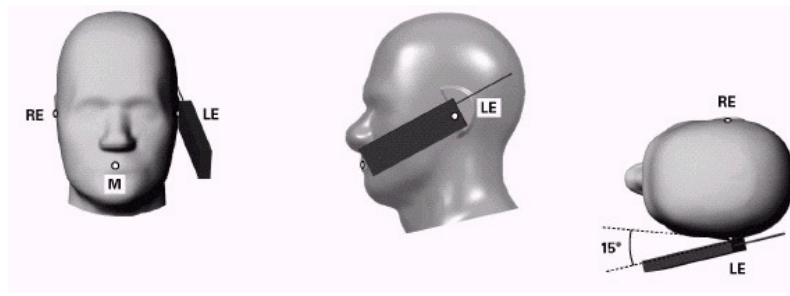

Figure 9-2 Front, Side and Top View of Ear/15° Tilt Position

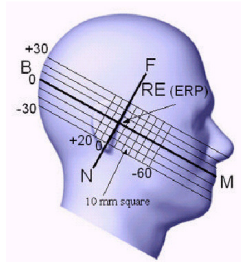

Figure 9-3 Side view w/ relevant markings



Figure 9-4 Body SAR Sample Photo (Not Actual EUT)

9.4 SAR Evaluations near the Mouth/Jaw Regions of the SAM Phantom

Antennas located near the bottom of a phone may require SAR measurements around the mouth and jaw regions of the SAM head phantom. This typically applies to clam-shell style phones that are generally longer in the unfolded normal use positions or to certain older style long rectangular phones. It has been known for some time that there are SAR measurement difficulties in these regions of the SAM phantom. SAR probes are calibrated in tissue equivalent liquids with sufficient separation between the probe sensors and nearby physical boundaries to ensure scattering does not affect probe calibration. When the probe tip is moved into tight regions with multiple boundaries surrounding its sensors, probe calibration and measurement accuracy can become questionable. In addition, these measurement locations often require a probe to be tilted at steep angles, where it may no longer comply with calibration requirements and measurement protocols, or satisfy the required measurement uncertainty. In some situations it is not feasible to tilt the probe or rotate the phantom, as suggested by measurement standards, to conduct these measurements.

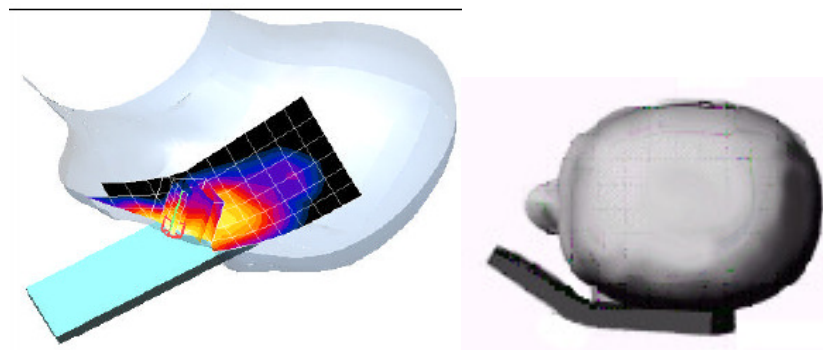



Figure 9-5 SAR Scans near the Jaw/Mouth

In order to ensure there is sufficient conservativeness for ensuring compliance until practical solutions are available, additional measurement considerations are necessary to address these technical difficulties. When measurements are required near the mouth, nose, jaw or similar tight regions of the SAM phantom,

FCC ID: A3LSWDSC02C	 PCTEST ENGINEERING LABORATORY, INC.	SAR COMPLIANCE REPORT		Reviewed by: Quality Manager
Filename: 0Y1104200782-R1.A3L	Test Dates: 05/02/11 - 05/04/11	EUT Type: 850/1900 GSM/GPRS/EDGE Phone with Bluetooth and WLAN		Page 13 of 45

area or zoom scans are often unable to fully enclose the peak SAR location as required by IEEE 1528 and Supplement C, due to probe orientation and positioning difficulties. Even when limited measurements are possible, the test results could be questionable due to probe calibration and measurement uncertainty issues. Under these circumstances, the following procedures apply, adopted from the FCC guidance on SAR handsets document publication 648474. The SAR required in these regions of SAM should be measured using a flat phantom. **Rectangular shaped phones** should be positioned with its bottom edge positioned from the flat phantom with the same distance provided by the cheek touching position using SAM. The ear reference point (ERP, as defined for SAM) of the phone should be positioned ½ cm from the flat phantom shell. **Clam-shell phones** should be positioned with the hinge against a smooth edge of the flat phantom where the upper half of the phone is unfolded and extended beyond the phantom side wall. The lower half of the phone is secured in the test device holder at a fixed distance below the flat phantom determined by the minimum separation along the lower edge of the phone in the cheek touching position using SAM. Any case with substantial variation in separation distance along the lower edge of a clam shell is discussed with the FCC for best-to-use methodology.



The flat phantom data should allow test results to be compared uniformly across measurement systems, until suitable solutions are available in measurement standards to address certain probe calibration and positioning issues, due to implementation differences between horizontal and upright SAM configurations. These flat phantom procedures are only applicable for stand-alone SAR evaluation in tight regions of the SAM phantom, where measurement is not feasible or test results can be questionable due to probe calibration and accessibility issues. Details on device positioning and photos showing how separation distances are determined are included in the SAR report Photographs. SAR for other regions of the head must be evaluated using SAM; therefore, a phone with antennas at different locations may require flat and SAM phantom evaluation for the different antennas.

9.5 Body Holster /Belt Clip Configurations

Body-worn operating configurations are tested with the belt-clips and holsters attached to the device and positioned against a flat phantom in a normal use configuration (see Figure 9-4). A device with a headset output is tested with a headset connected to the device.

Accessories for Body-worn operation configurations are divided into two categories: those that do not contain metallic components and those that do contain metallic components. When multiple accessories that do not contain metallic components are supplied with the device, the device is tested with only the accessory that dictates the closest spacing to the body. Then multiple accessories that contain metallic components are tested with the device with each accessory. If multiple accessories share an identical metallic component (i.e. the same metallic belt-clip used with different holsters with no other metallic components) only the accessory that dictates the closest spacing to the body is tested.

Body-worn accessories may not always be supplied or available as options for some devices intended to be authorized for body-worn use. In this case, a test configuration with a separation distance between the back of the device and the flat phantom is used. Test position spacing was documented. Transmitters that are designed to operate in front of a person's face, as in push-to-talk configurations, are tested for SAR compliance with the front of the device positioned to face the flat phantom in head fluid. For devices that are carried next to the body such as a shoulder, waist or chest-worn transmitters, SAR compliance is tested with the accessories, including headsets and microphones, attached to the device and positioned against a flat phantom in a normal use configuration.

FCC ID: A3LSWDSC02C	 PCTEST ENGINEERING LABORATORY, INC.	SAR COMPLIANCE REPORT		Reviewed by: Quality Manager
Filename: 0Y1104200782-R1.A3L	Test Dates: 05/02/11 - 05/04/11	EUT Type: 850/1900 GSM/GPRS/EDGE Phone with Bluetooth and WLAN		Page 14 of 45

10 FCC RF EXPOSURE LIMITS

10.1 Uncontrolled Environment

UNCONTROLLED ENVIRONMENTS are defined as locations where there is the exposure of individuals who have no knowledge or control of their exposure. The general population/uncontrolled exposure limits are applicable to situations in which the general public may be exposed or in which persons who are exposed as a consequence of their employment may not be made fully aware of the potential for exposure or cannot exercise control over their exposure. Members of the general public would come under this category when exposure is not employment-related; for example, in the case of a wireless transmitter that exposes persons in its vicinity.



10.2 Controlled Environment

CONTROLLED ENVIRONMENTS are defined as locations where there is exposure that may be incurred by persons who are aware of the potential for exposure, (i.e. as a result of employment or occupation). In general, occupational/controlled exposure limits are applicable to situations in which persons are exposed as a consequence of their employment, who have been made fully aware of the potential for exposure and can exercise control over their exposure. This exposure category is also applicable when the exposure is of a transient nature due to incidental passage through a location where the exposure levels may be higher than the general population/uncontrolled limits, but the exposed person is fully aware of the potential for exposure and can exercise control over his or her exposure by leaving the area or by some other appropriate means.

Table 10-1
SAR Human Exposure Specified in ANSI/IEEE C95.1-1992 and Health Canada Safety Code 6

HUMAN EXPOSURE LIMITS		
	UNCONTROLLED ENVIRONMENT <i>General Population</i> (W/kg) or (mW/g)	CONTROLLED ENVIRONMENT <i>Occupational</i> (W/kg) or (mW/g)
SPATIAL PEAK SAR Brain	1.6	8.0
SPATIAL AVERAGE SAR Whole Body	0.08	0.4
SPATIAL PEAK SAR Hands, Feet, Ankles, Wrists	4.0	20

1. The Spatial Peak value of the SAR averaged over any 1 gram of tissue (defined as a tissue volume in the shape of a cube) and over the appropriate averaging time.
2. The Spatial Average value of the SAR averaged over the whole body.
3. The Spatial Peak value of the SAR averaged over any 10 grams of tissue (defined as a tissue volume in the shape of a cube) and over the appropriate averaging time.

FCC ID: A3LSWDSC02C	 PCTEST ENGINEERING LABORATORY, INC.	SAR COMPLIANCE REPORT		Reviewed by: Quality Manager
Filename: 0Y1104200782-R1.A3L	Test Dates: 05/02/11 - 05/04/11	EUT Type: 850/1900 GSM/GPRS/EDGE Phone with Bluetooth and WLAN		Page 15 of 45

11 FCC 3G MEASUREMENT PROCEDURES

Power measurements were performed using a base station simulator under digital average power.

11.1 Procedures Used to Establish RF Signal for SAR

The device was placed into a simulated call using a base station simulator in a shielded chamber. Such test signals offer a consistent means for testing SAR and are recommended for evaluating SAR [4]. SAR measurements were taken with a fully charged battery. In order to verify that the device was tested and maintained at full power, it was configured with the base station simulator. The SAR measurement software calculates a reference point at the start and end of the test to check for power drifts. If SAR deviations of more than 5% occurred, the tests were repeated.

11.2 RF Conducted Powers

11.2.1 GSM Conducted Powers

		Maximum Burst-Averaged Output Power									
		Voice	GPRS Data (GMSK)				EDGE (8PSK) Data				
Band	Channel	GSM [dBm] CS (1 Slot)	GPRS [dBm] 1 Tx Slot	GPRS [dBm] 2 Tx Slot	GPRS [dBm] 3 Tx Slot	GPRS [dBm] 4 Tx Slot	EDGE [dBm] 1 Tx Slot	EDGE [dBm] 2 Tx Slot	EDGE [dBm] 3 Tx Slot	EDGE [dBm] 4 Tx Slot	
Cellular	128	32.22	32.26	30.35	28.96	27.31	26.51	26.52	26.51	23.33	
	190	32.26	32.27	30.34	28.94	27.34	26.58	26.61	26.58	23.37	
	251	32.26	32.31	30.28	28.91	27.36	26.60	26.62	26.62	23.40	
PCS	512	29.64	29.64	28.78	26.80	25.67	25.69	25.68	25.65	22.93	
	661	29.69	29.68	28.81	26.82	25.72	25.75	25.72	25.72	22.95	
	810	29.72	29.72	28.84	26.85	25.74	25.78	25.78	25.75	23.00	

		Maximum Frame-Averaged Output Power									
		Voice	GPRS Data				EDGE Data				
Band	Channel	GSM [dBm] CS (1 Slot)	GPRS [dBm] 1 Tx Slot	GPRS [dBm] 2 Tx Slot	GPRS [dBm] 3 Tx Slot	GPRS [dBm] 4 Tx Slot	EDGE [dBm] 1 Tx Slot	EDGE [dBm] 2 Tx Slot	EDGE [dBm] 3 Tx Slot	EDGE [dBm] 4 Tx Slot	
Cellular	128	23.19	23.23	24.33	24.70	24.30	17.48	20.50	22.25	20.32	
	190	23.23	23.24	24.32	24.68	24.33	17.55	20.59	22.32	20.36	
	251	23.23	23.28	24.26	24.65	24.35	17.57	20.60	22.36	20.39	
PCS	512	20.61	20.61	22.76	22.54	22.66	16.66	19.66	21.39	19.92	
	661	20.66	20.65	22.79	22.56	22.71	16.72	19.70	21.46	19.94	
	810	20.69	20.69	22.82	22.59	22.73	16.75	19.76	21.49	19.99	

Note: Frame-averaged power was calculated from the measured burst-averaged power. The bolded GPRS/EDGE modes were selected according to the highest frame-averaged output power table per KDB Publication 941225 D03.

GSM Class: B
GPRS Multislot class: 12 (max 4 Tx Uplink slots)
EDGE Multislot class: 12 (max 4 Tx Uplink slots)
DTM Multislot Class: N/A

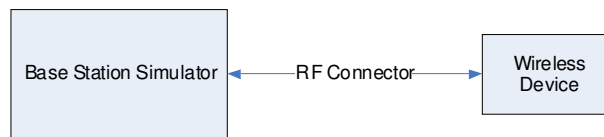

Figure 11-1
Power Measurement Setup

FCC ID: A3LSWDSC02C	PCTEST ENGINEERING LABORATORY, INC.	SAR COMPLIANCE REPORT		Reviewed by: Quality Manager
Filename: 0Y1104200782-R1.A3L	Test Dates: 05/02/11 - 05/04/11	EUT Type: 850/1900 GSM/GPRS/EDGE Phone with Bluetooth and WLAN		Page 16 of 45

12 SAR TESTING WITH IEEE 802.11 TRANSMITTERS

Normal network operating configurations are not suitable for measuring the SAR of 802.11 a/b/g transmitters. Unpredictable fluctuations in network traffic and antenna diversity conditions can introduce undesirable variations in SAR results. The SAR for these devices should be measured using chipset based test mode software to ensure the results are consistent and reliable.

12.1 General Device Setup

Chipset based test mode software is hardware dependent and generally varies among manufacturers. The device operating parameters established in test mode for SAR measurements must be identical to those programmed in production units, including output power levels, amplifier gain settings and other RF performance tuning parameters. The test frequencies should correspond to actual channel frequencies defined for domestic use. SAR for devices with switched diversity should be measured with only one antenna transmitting at a time during each SAR measurement, according to a fixed modulation and data rate. The same data pattern should be used for all measurements.

12.2 Frequency Channel Configurations [27]

802.11 a/b/g and 4.9 GHz operating modes are tested independently according to the service requirements in each frequency band. 802.11 b/g modes are tested on channels 1, 6 and 11. 802.11a is tested for UNII operations on channels 36 and 48 in the 5.15-5.25 GHz band; channels 52 and 64 in the 5.25-5.35 GHz band; channels 104, 116, 124 and 136 in the 5.470-5.725 GHz band; and channels 149 and 161 in the 5.8 GHz band. When 5.8 GHz §15.247 is also available, channels 149, 157 and 165 should be tested instead of the UNII channels. 4.9 GHz is tested on channels 1, 10 and 5 or 6, whichever has the higher output power, for 5 MHz channels; channels 11, 15 and 19 for 10 MHz channels; and channels 21 and 25 for 20 MHz channels. These are referred to as the “default test channels”. 802.11g mode was evaluated only if the output power was 0.25 dB higher than the 802.11b mode.

**Table 12-1
802.11 Test Channels per FCC Requirements**

Mode	GHz	Channel	Turbo Channel	“Default Test Channels”			
				§15.247	UNII		
				802.11b	802.11g		
802.11 b/g	2.412	1		√	∇		
	2.437	6	6	√	∇		
	2.462	11		√	∇		
802.11a	5.18	36				√	
	5.20	40	42 (5.21 GHz)			*	
	5.22	44				*	
	5.24	48	50 (5.25 GHz)			√	
	5.26	52				√	
	5.28	56	58 (5.29 GHz)			*	
	5.30	60				*	
	5.32	64				√	
	UNII	5.500	100	Unknown			*
		5.520	104				√
		5.540	108				*
		5.560	112				*
		5.580	116				√
		5.600	120				*
		5.620	124				√
		5.640	128				*
		5.660	132				*
		5.680	136				√
	5.700	140			*		
	UNII or §15.247	5.745	149		√		√
5.765		153	152 (5.76 GHz)		*	*	
5.785		157		√		*	
5.805		161	160 (5.80 GHz)		*	√	
§15.247		5.825	165		√		



FCC ID: A3LSWDSC02C	 PCTEST ENGINEERING LABORATORY, INC.	SAR COMPLIANCE REPORT		Reviewed by: Quality Manager
Filename: 0Y1104200782-R1.A3L	Test Dates: 05/02/11 - 05/04/11	EUT Type: 850/1900 GSM/GPRS/EDGE Phone with Bluetooth and WLAN		Page 17 of 45

Table 12-2
IEEE 802.11b Average RF Power

Mode	Freq [MHz]	Channel	Conducted Power [dBm]			
			Data Rate [Mbps]			
			1	2	5.5	11
802.11b	2412	1	16.99	16.93	16.97	16.66
802.11b	2437	6	17.13	17.26	17.06	16.85
802.11b	2462	11	17.22	17.09	17.08	16.83

Table 12-3
IEEE 802.11g Average RF Power



Mode	Freq [MHz]	Channel	802.11g Conducted Power [dBm]							
			Data Rate [Mbps]							
			6	9	12	18	24	36	48	54
802.11g	2412	1	14.42	14.34	14.24	14.28	14.22	14.24	14.29	14.28
802.11g	2437	6	14.43	14.43	14.44	14.46	14.36	14.32	14.36	14.36
802.11g	2462	11	14.39	14.38	14.39	14.35	14.33	14.27	14.34	14.36

Table 12-4
IEEE 802.11n Average RF Power

Mode	Freq [MHz]	Channel	2.4GHz 802.11n Conducted Power [dBm]							
			Data Rate [Mbps]							
			6.5/7.2	13/14.4	19.5/21.7	26/28.9	39/43.3	52/57.8	58.5/65	65/72.2
802.11n	2412	1	12.37	12.34	12.43	12.49	12.42	12.43	12.47	12.48
802.11n	2437	6	12.56	12.44	12.47	12.49	12.46	12.48	12.55	12.58
802.11n	2462	11	12.49	12.42	12.49	12.48	12.54	12.44	12.53	12.59

Table 12-5
IEEE 802.11a Average RF Power

Mode	Freq [MHz]	Channel	802.11a Conducted Power [dBm]							
			Data Rate [Mbps]							
			6	9	12	18	24	36	48	54
802.11a	5180	36	11.48	11.38	11.50	11.60	11.62	11.50	11.50	11.60
802.11a	5200	40	11.27	11.30	11.35	11.42	11.36	11.38	11.40	11.41
802.11a	5220	44	11.07	11.04	11.03	10.12	11.05	11.06	11.11	11.09
802.11a	5240	48	11.00	11.25	11.20	11.30	11.30	11.20	11.30	11.36
802.11a	5260	52	12.25	12.22	12.20	12.22	12.20	12.28	12.35	12.31
802.11a	5280	56	12.20	12.20	12.22	12.30	12.25	12.30	12.40	12.30
802.11a	5300	60	11.83	11.94	11.92	11.98	11.99	11.87	11.98	12.01
802.11a	5320	64	12.15	12.15	12.35	12.30	12.25	12.22	12.41	12.28
802.11a	5500	100	11.95	12.20	12.16	12.22	12.18	12.25	12.28	12.20
802.11a	5520	104	11.57	11.52	11.55	11.58	11.53	11.52	11.61	11.63
802.11a	5540	108	11.74	11.90	11.94	11.97	11.98	11.96	12.06	12.07
802.11a	5560	112	11.91	12.00	11.99	12.02	11.96	12.01	12.14	12.14
802.11a	5580	116	11.89	12.01	12.00	12.18	12.06	12.09	12.13	12.15
802.11a	5600	120	12.30	12.40	12.42	12.42	12.32	12.50	12.51	12.45
802.11a	5620	124	12.06	12.11	12.15	12.10	12.15	12.14	12.21	12.21
802.11a	5640	128	12.11	12.15	12.14	12.18	12.18	12.19	12.22	12.26
802.11a	5660	132	12.16	12.25	12.23	12.27	12.26	12.23	12.33	12.32
802.11a	5680	136	12.23	12.22	12.26	12.34	12.28	12.26	12.29	12.32
802.11a	5700	140	12.60	12.75	12.72	12.80	12.78	12.75	12.84	12.81
802.11a	5745	149	12.42	12.44	12.41	12.48	12.41	12.44	12.17	12.23
802.11a	5765	153	12.21	12.18	12.29	12.38	12.29	12.25	12.31	12.42
802.11a	5785	157	12.31	12.33	12.27	12.31	12.36	12.33	12.28	12.23
802.11a	5805	161	12.21	12.22	12.31	12.32	12.45	12.38	12.46	12.42

FCC ID: A3LSWDSC02C	 PCTEST ENGINEERING LABORATORY, INC.	SAR COMPLIANCE REPORT		Reviewed by: Quality Manager
Filename: 0Y1104200782-R1.A3L	Test Dates: 05/02/11 - 05/04/11	EUT Type: 850/1900 GSM/GPRS/EDGE Phone with Bluetooth and WLAN		Page 18 of 45

**Table 12-6
IEEE 802.11n Average RF Power**

Mode	Freq [MHz]	Channel	Tx Chain	Cable Loss [dB]	5GHz 802.11n Conducted Power [dBm]							
					Data Rate [Mbps]							
					6.5/7.2	13/14.4	19.5/21.7	26/28.9	39/43.3	52/57.8	58.5/65	65/72.2
802.11n	5180	36			10.23	10.17	10.30	10.25	10.32	10.43	10.42	10.45
802.11n	5200	40			10.08	10.05	10.15	10.22	10.22	10.26	10.30	10.35
802.11n	5220	44			9.73	9.84	9.98	9.95	10.01	10.09	10.05	10.08
802.11n	5240	48			10.00	9.90	10.08	10.10	10.06	10.10	10.15	10.16
802.11n	5260	52			9.90	9.88	9.95	10.06	10.00	10.10	10.17	10.14
802.11n	5280	56			9.90	9.80	9.95	10.05	10.00	10.10	10.10	10.06
802.11n	5300	60			9.87	9.88	9.98	10.02	10.07	10.11	10.08	10.14
802.11n	5320	64			9.75	9.85	10.00	9.90	9.95	10.00	10.00	10.05
802.11n	5500	100			9.82	9.85	10.00	9.98	10.10	10.12	10.00	10.20
802.11n	5520	104			9.72	9.64	9.85	9.78	9.91	9.87	9.91	9.91
802.11n	5540	108			9.65	9.64	9.79	9.83	9.86	9.84	9.92	9.89
802.11n	5560	112			9.64	9.68	9.82	9.86	9.88	9.91	9.95	10.01
802.11n	5580	116			9.66	9.72	9.84	9.89	10.01	10.03	10.02	10.05
802.11n	5600	120			10.01	10.02	10.21	10.25	10.31	10.30	10.31	10.25
802.11n	5620	124			9.77	9.93	10.05	10.09	10.04	10.08	10.11	10.13
802.11n	5640	128			9.97	9.97	10.02	10.03	10.09	10.09	10.15	10.15
802.11n	5660	132			9.96	9.96	10.11	10.14	10.17	10.20	10.25	10.28
802.11n	5680	136			9.97	10.01	10.03	10.17	10.23	10.17	10.21	10.25
802.11n	5700	140			10.50	10.60	10.65	10.63	10.70	10.80	10.79	10.82
802.11n	5745	149			12.02	11.95	12.05	12.39	12.37	12.43	12.43	12.51
802.11n	5765	153			12.02	12.08	12.22	12.13	12.21	12.22	12.25	12.34
802.11n	5785	157			12.13	12.06	12.21	12.23	12.17	12.26	12.25	12.18
802.11n	5805	161			12.13	12.14	12.26	12.27	12.44	12.36	12.37	12.41

12.3 SAR Test Configurations

Justification for reduced test configurations for WIFI channels per KDB Publication 248227 and April 2010 FCC/TCB Meeting Notes: IEEE 802.11n for 5GHz bands and IEEE 802.11g/n for 2.4 GHz Bands and higher data rates for both bands were not investigated since the average output powers were not greater than 0.25 dB that of the corresponding channel in the lowest data rate. Bolded powers in Section 12.2 were tested for SAR.

5825 MHz transmission is not supported in this device.



**Figure 12-1
Power Measurement Setup**

FCC ID: A3LSWDSC02C	PCTEST ENGINEERING LABORATORY, INC.	SAR COMPLIANCE REPORT		Reviewed by: Quality Manager
Filename: 0Y1104200782-R1.A3L	Test Dates: 05/02/11 - 05/04/11	EUT Type: 850/1900 GSM/GPRS/EDGE Phone with Bluetooth and WLAN		Page 19 of 45

13 PERSONAL WIRELESS ROUTER CONSIDERATIONS

13.1 Personal Wireless Router Considerations by the FCC

Some battery-operated handsets have the capability to transmit and receive internet connectivity through simultaneous transmission of WIFI in conjunction with a separate licensed transmitter. The FCC has provided guidance in KDB Publication 941225 D06 where SAR test considerations are based on a composite test separation distance of 10 mm from the edges, front and back of the device with antennas 2.5 cm or closer to the edge of the device, determined from general mixed use conditions for this type of devices.

Since the hotspot SAR results may overlap with the body-worn accessory SAR requirements, the more conservative configurations can be considered, thus excluding some body-worn accessory SAR tests.

This device supports portable hotspot mode for 2.4 GHz WLAN only. 5GHz WLAN is not supported for hotspot mode.



13.2 SAR Test Setup for Personal Wireless Router Features

When the user enables the personal wireless router functions for the handset, actual operations include simultaneous transmission of both the WIFI transmitter and another licensed transmitter. Both transmitters often do not transmit at the same transmitting frequency and thus cannot be evaluated for SAR under actual use conditions.

Therefore, SAR must be evaluated for each frequency transmission and mode separately and summed with the WIFI transmitter according to KDB 648474 publication procedures. Therefore, the measurements were performed for each standalone transmitter for the required exposure conditions. The "Portable Hotspot" feature on the handset was NOT activated, to ensure the SAR measurements were valid within a single transmission frequency.

13.3 Power Reduction for Portable Hotspot Mode

This device does not implement any power reduction when placed in "Portable Hotspot" mode.

FCC ID: A3LSWDSC02C		SAR COMPLIANCE REPORT		Reviewed by: Quality Manager
Filename: 0Y1104200782-R1.A3L	Test Dates: 05/02/11 - 05/04/11	EUT Type: 850/1900 GSM/GPRS/EDGE Phone with Bluetooth and WLAN		Page 20 of 45

13.4 SAR Test Configurations

**Table 13-1
Mobile Hotspot Sides for SAR Testing**

Mobile Hotspot Sides for SAR Testing						
Mode	Back	Front	Top	Bottom	Right	Left
GPRS 850	Yes	Yes	No	Yes	Yes	No
GPRS 1900	Yes	Yes	No	Yes	Yes	No
2.4 GHz WLAN	Yes	Yes	No	Yes	No	Yes

Note: 5 GHz Wifi was not considered in the above table because 5 GHz Wifi is not operational in hotspot mode.

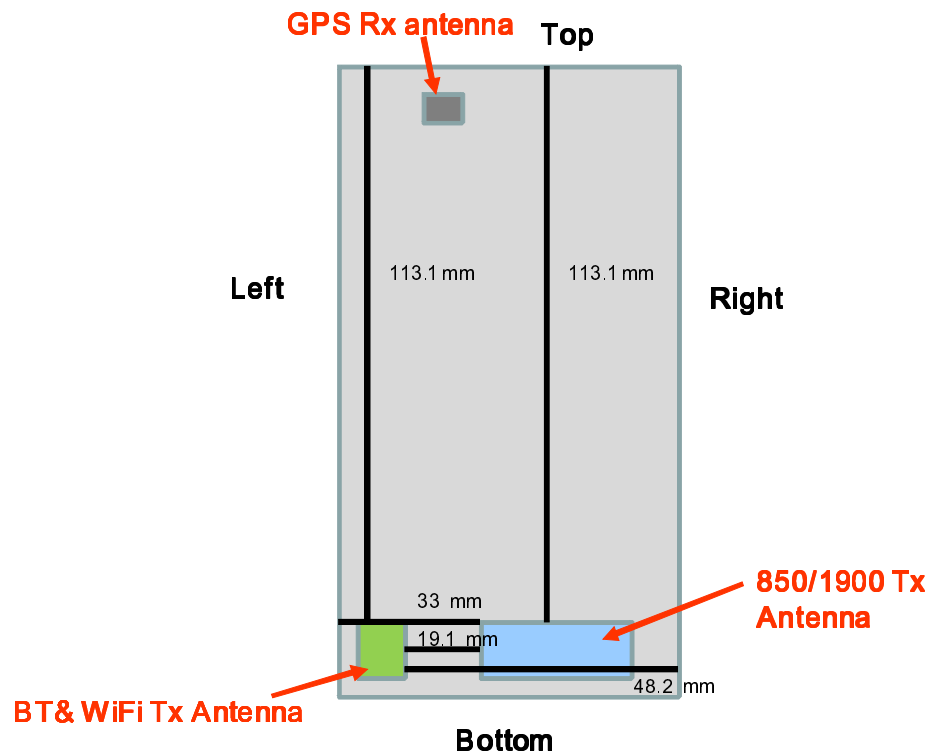



Figure 13-1 Identification of Sides for SAR Testing (Front View)

Note: Per FCC KDB Publication 941225 D06, the edges with antennas within 2.5 cm are required to be evaluated for SAR. See Figure 13-1 for distances of the actual device.



FCC ID: A3LSWDSC02C	 PCTEST ENGINEERING LABORATORY, INC.	SAR COMPLIANCE REPORT		Reviewed by: Quality Manager
Filename: 0Y1104200782-R1.A3L	Test Dates: 05/02/11 - 05/04/11	EUT Type: 850/1900 GSM/GPRS/EDGE Phone with Bluetooth and WLAN		Page 21 of 45

14 SYSTEM VERIFICATION

14.1 Tissue Verification

**Table 14-1
Measured Tissue Properties**

Calibrated for Tests Performed on:	Tissue Type	Measured Frequency (MHz)	Measured Conductivity, σ (S/m)	Measured Dielectric Constant, ϵ	TARGET Conductivity, σ (S/m)	TARGET Dielectric Constant, ϵ	% dev σ	% dev ϵ
05/04/2011	835H	820	0.858	39.75	0.90	41.57	-4.45%	-4.38%
		835	0.866	39.77	0.90	41.50	-3.78%	-4.17%
		850	0.879	39.71	0.92	41.50	-4.04%	-4.31%
05/04/2011	835B	820	0.947	53.20	0.97	55.28	-2.27%	-3.77%
		835	0.957	53.13	0.97	55.20	-1.34%	-3.75%
		850	0.969	53.21	0.99	55.15	-1.92%	-3.52%
05/02/2011	1900H	1850	1.410	40.64	1.40	40.00	0.71%	1.60%
		1880	1.436	40.43	1.40	40.00	2.57%	1.08%
		1910	1.463	40.44	1.40	40.00	4.50%	1.10%
05/03/2011	1900B	1850	1.510	52.65	1.52	53.30	-0.66%	-1.22%
		1880	1.533	52.63	1.52	53.30	0.86%	-1.26%
		1910	1.569	52.41	1.52	53.30	3.22%	-1.67%
05/03/2011	2450H	2401	1.824	37.64	1.76	39.30	3.75%	-4.22%
		2450	1.885	37.44	1.80	39.20	4.72%	-4.49%
		2499	1.939	37.18	1.85	39.14	4.70%	-5.00%
05/02/2011	2450B	2401	1.949	50.46	1.90	52.77	2.42%	-4.37%
		2450	2.008	50.18	1.95	52.70	2.97%	-4.78%
		2499	2.078	50.05	2.02	52.64	2.92%	-4.92%
05/04/2011	5200H-5800H	5170	4.724	37.45	4.63	36.03	2.05%	3.94%
		5210	4.754	37.26	4.67	35.99	1.80%	3.53%
		5250	4.782	37.03	4.71	35.95	1.53%	3.00%
		5270	4.833	37.08	4.73	35.93	2.18%	3.20%
		5310	4.898	37.06	4.77	35.89	2.68%	3.26%
		5350	4.899	37.02	4.81	35.85	1.85%	3.26%
		5470	5.095	36.75	4.93	35.70	3.26%	2.96%
		5510	5.171	36.67	4.98	35.64	3.92%	2.90%
		5550	5.163	36.57	5.02	35.58	2.89%	2.80%
		5570	5.198	36.49	5.04	35.55	3.16%	2.66%
		5610	5.263	36.62	5.08	35.49	3.60%	3.18%
		5650	5.284	36.37	5.12	35.45	3.20%	2.60%
		5670	5.302	36.34	5.14	35.43	3.15%	2.57%
		5710	5.409	36.22	5.18	35.39	4.42%	2.35%
		5750	5.428	36.09	5.22	35.35	3.98%	2.09%
		5770	5.445	36.15	5.24	35.33	3.91%	2.32%
5810	5.523	35.96	5.28	35.29	4.58%	1.90%		
5850	5.549	35.94	5.32	35.25	4.25%	1.96%		
05/04/2011	5200B-5800B	5170	5.244	49.21	5.26	49.06	-0.38%	0.32%
		5210	5.324	48.90	5.31	49.00	0.24%	-0.21%
		5250	5.400	49.06	5.36	48.95	0.78%	0.23%
		5270	5.371	48.95	5.38	48.92	-0.19%	0.06%
		5310	5.512	48.81	5.43	48.87	1.55%	-0.11%
		5350	5.542	48.65	5.47	48.81	1.32%	-0.33%
		5470	5.684	48.28	5.62	48.65	1.23%	-0.76%
		5510	5.769	48.49	5.66	48.59	1.91%	-0.21%
		5550	5.804	48.15	5.71	48.54	1.68%	-0.80%
		5570	5.855	48.15	5.73	48.51	2.16%	-0.75%
		5610	5.845	48.18	5.78	48.46	1.16%	-0.57%
		5650	6.025	47.90	5.83	48.40	3.43%	-1.04%
		5670	6.003	48.09	5.85	48.38	2.65%	-0.59%
		5710	6.055	47.91	5.90	48.32	2.71%	-0.85%
		5750	6.167	47.70	5.94	48.27	3.79%	-1.18%
		5770	6.216	47.74	5.97	48.24	4.21%	-1.04%
5810	6.154	47.64	6.01	48.19	2.36%	-1.13%		
5850	6.304	47.56	6.06	48.13	4.06%	-1.19%		

FCC ID: A3LSWDSC02C	 PCTEST ENGINEERING LABORATORY, INC.	SAR COMPLIANCE REPORT		Reviewed by: Quality Manager
Filename: 0Y1104200782-R1.A3L	Test Dates: 05/02/11 - 05/04/11	EUT Type: 850/1900 GSM/GPRS/EDGE Phone with Bluetooth and WLAN		Page 22 of 45

Notes:

1. KDB Publication 450824 was ensured to be applied for probe calibration frequencies greater than or equal to 50 MHz of the DUT frequencies.
2. Probe calibration used within ± 100 MHz of the test frequency in either 5.725 - 5.85 or 5.47-5.725 GHz is acceptable per KDB Publication 865664 since the design of the SAR probe supports the extended frequency, provided the DASY software version recommended is used for the tests, and the expanded calibration uncertainty (k=2) is less than or equal to 15% (See SAR probe calibration certificate for this information). The dielectric and conductivities measured are within 10% and 5% respectively of the target parameters specified in Supplement C 01-01



The above measured tissue parameters were used in the DASY software to perform interpolation via the DASY software to determine actual dielectric parameters at the test frequencies (per IEEE 1528 6.6.1.2). The SAR test plots may slightly differ from the table above since the DASY software rounds to three significant digits.

14.2 Measurement Procedure for Tissue verification

- 1) The network analyzer and probe system was configured and calibrated.
- 2) The probe was immersed in the sample which was placed in a nonmetallic container. Trapped air bubbles beneath the flange were minimized by placing the probe at a slight angle.
- 3) The complex admittance with respect to the probe aperture was measured
- 4) The complex relative permittivity, for example from the below equation (Pournaropoulos and Misra):

$$Y = \frac{j2\omega\epsilon_r\epsilon_0}{[\ln(b/a)]^2} \int_a^b \int_a^b \int_0^\pi \cos\phi' \frac{\exp[-j\omega r(\mu_0\epsilon_r\epsilon_0)^{1/2}]}{r} d\phi' d\rho' d\rho$$

where Y is the admittance of the probe in contact with the sample, the primed and unprimed coordinates refer to source and observation points, respectively, $r^2 = \rho^2 + \rho'^2 - 2\rho\rho' \cos\phi'$, ω is the angular frequency, and $j = \sqrt{-1}$.

FCC ID: A3LSWDSC02C		SAR COMPLIANCE REPORT		Reviewed by: Quality Manager
Filename: 0Y1104200782-R1.A3L	Test Dates: 05/02/11 - 05/04/11	EUT Type: 850/1900 GSM/GPRS/EDGE Phone with Bluetooth and WLAN	Page 23 of 45	

14.3 Test System Verification

Prior to assessment, the system is verified to $\pm 10\%$ of the manufacturer SAR measurement on the reference dipole at the time of calibration.

**Table 14-2
System Verification Results**

System Verification TARGET & MEASURED										
Date:	Amb. Temp (°C)	Liquid Temp (°C)	Input Power (W)	Tissue Frequency (MHz)	Dipole SN	Tissue Type	Measured SAR _{1g} (W/kg)	1 W Target SAR _{1g} (W/kg)	1 W Normalized SAR _{1g} (W/kg)	Deviation (%)
05/04/2011	24.0	22.6	0.063	835	4d047	Head	0.571	9.530	9.063	-4.90%
05/04/2011	24.2	22.4	0.063	835	4d047	Body	0.617	9.850	9.794	-0.57%
05/02/2011	23.9	22.8	0.040	1900	502	Head	1.63	40.200	40.750	1.37%
05/03/2011	23.3	22.2	0.040	1900	502	Body	1.7	41.100	42.500	3.41%
05/03/2011	23.3	22.0	0.025	2450	797	Head	1.41	53.300	56.400	5.82%
05/02/2011	24.3	22.4	0.025	2450	797	Body	1.28	52.300	51.200	-2.10%
05/04/2011	24.3	22.8	0.025	5200	1057	Head	2.2	83.100	88.000	5.90%
05/04/2011	24.3	22.6	0.025	5200	1057	Body	2.01	77.700	80.400	3.47%
05/04/2011	23.4	22.5	0.025	5500	1057	Head	2.27	90.100	90.800	0.78%
05/04/2011	24.5	22.7	0.025	5500	1057	Body	2.13	84.400	85.200	0.95%
05/04/2011	23.9	22.8	0.025	5800	1057	Head	2.15	82.900	86.000	3.74%
05/04/2011	24.6	22.9	0.025	5800	1057	Body	1.94	75.000	77.600	3.47%

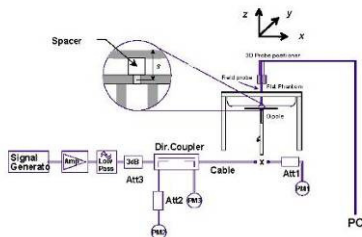

**Figure 14-1
System Verification Setup Diagram**



**Figure 14-2
System Verification Setup Photo**

FCC ID: A3LSWDSC02C		SAR COMPLIANCE REPORT		Reviewed by: Quality Manager
Filename: 0Y1104200782-R1.A3L	Test Dates: 05/02/11 - 05/04/11	EUT Type: 850/1900 GSM/GPRS/EDGE Phone with Bluetooth and WLAN		Page 24 of 45



15 SAR DATA SUMMARY

**Table 15-1
GSM 850 Head SAR Results**

MEASUREMENT RESULTS								
FREQUENCY		Mode/Band	Conducted Power [dBm]	Power Drift [dB]	Side	Test Position	Serial Number	SAR (1g)
MHz	Ch.							(W/kg)
836.60	190	GSM 850	32.26	-0.04	Right	Touch	FI-095-A	0.235
836.60	190	GSM 850	32.26	0.01	Right	Tilt	FI-095-A	0.153
836.60	190	GSM 850	32.26	0.01	Left	Touch	FI-095-A	0.207
836.60	190	GSM 850	32.26	0.07	Left	Tilt	FI-095-A	0.133
ANSI / IEEE C95.1 1992 - SAFETY LIMIT Spatial Peak Uncontrolled Exposure/General Population					Head 1.6 W/kg (mW/g) averaged over 1 gram			

Notes:

1. The test data reported are the worst-case SAR value with the position set in a typical configuration. Test procedures used were according to FCC/OET Bulletin 65, Supplement C [June 2001].
2. All modes of operation were investigated, and worst-case results are reported.
3. Batteries are fully charged for all readings. Standard battery was used.
4. Tissue parameters and temperatures are listed on the SAR plots.
5. Liquid tissue depth was at least 15.0 cm.
6. Justification for reduced test configurations: Per FCC/OET Bulletin 65 Supplement C (June 2001) and Public Notice DA-02-1438, if the SAR measured at the middle channel for each test configuration (left, right, cheek/touch, tilt/ear, extended and retracted) is at least 3.0 dB lower than the SAR limit, testing at the high and low channels is optional for such test configuration(s).
7. All samples tested were electrically identical per the applicant.



FCC ID: A3LSWDSC02C	 PCTEST ENGINEERING LABORATORY, INC.	SAR COMPLIANCE REPORT		Reviewed by: Quality Manager
Filename: 0Y1104200782-R1.A3L	Test Dates: 05/02/11 - 05/04/11	EUT Type: 850/1900 GSM/GPRS/EDGE Phone with Bluetooth and WLAN	Page 25 of 45	

**Table 15-2
GSM 1900 Head SAR Results**

MEASUREMENT RESULTS								
FREQUENCY		Mode/Band	Conducted Power [dBm]	Power Drift [dB]	Side	Test Position	Serial Number	SAR (1g)
MHz	Ch.							(W/kg)
1880.00	661	GSM 1900	29.69	0.03	Right	Touch	FI-095-A	0.071
1880.00	661	GSM 1900	29.69	0.12	Right	Tilt	FI-095-A	0.020
1880.00	661	GSM 1900	29.69	0.09	Left	Touch	FI-095-A	0.087
1880.00	661	GSM 1900	29.69	0.10	Left	Tilt	FI-095-A	0.024
ANSI / IEEE C95.1 1992 - SAFETY LIMIT					Head			
Spatial Peak					1.6 W/kg (mW/g)			
Uncontrolled Exposure/General Population					averaged over 1 gram			

Notes:

1. The test data reported are the worst-case SAR value with the position set in a typical configuration. Test procedures used were according to FCC/OET Bulletin 65, Supplement C [June 2001].
2. All modes of operation were investigated, and worst-case results are reported.
3. Batteries are fully charged for all readings. Standard battery was used.
4. Tissue parameters and temperatures are listed on the SAR plots.
5. Liquid tissue depth was at least 15.0 cm.
6. Justification for reduced test configurations: Per FCC/OET Bulletin 65 Supplement C (June 2001) and Public Notice DA-02-1438, if the SAR measured at the middle channel for each test configuration (left, right, cheek/touch, tilt/ear, extended and retracted) is at least 3.0 dB lower than the SAR limit, testing at the high and low channels is optional for such test configuration(s).
7. All samples tested were electrically identical per the applicant.



FCC ID: A3LSWDSC02C	 PCTEST ENGINEERING LABORATORY, INC.	SAR COMPLIANCE REPORT		Reviewed by: Quality Manager
Filename: 0Y1104200782-R1.A3L	Test Dates: 05/02/11 - 05/04/11	EUT Type: 850/1900 GSM/GPRS/EDGE Phone with Bluetooth and WLAN		Page 26 of 45

**Table 15-3
5 GHz WLAN Head SAR Results**

MEASUREMENT RESULTS										
FREQUENCY		Mode/Band	Service	Conducted Power [dBm]	Power Drift [dB]	Side	Test Position	Serial Number	Data Rate (Mbps)	SAR (1g)
MHz	Ch.									(W/kg)
5180	36	IEEE 802.11a	OFDM	11.48	0.07	Right	Touch	FI-095-B	6	0.021
5180	36	IEEE 802.11a	OFDM	11.48	-0.08	Right	Tilt	FI-095-B	6	0.002
5180	36	IEEE 802.11a	OFDM	11.48	0.09	Left	Touch	FI-095-B	6	0.008
5180	36	IEEE 802.11a	OFDM	11.48	0.05	Left	Tilt	FI-095-B	6	0.000
5260	52	IEEE 802.11a	OFDM	12.25	0.08	Right	Touch	FI-095-B	6	0.025
5260	52	IEEE 802.11a	OFDM	12.25	0.10	Right	Tilt	FI-095-B	6	0.004
5260	52	IEEE 802.11a	OFDM	12.25	0.09	Left	Touch	FI-095-B	6	0.018
5260	52	IEEE 802.11a	OFDM	12.25	0.07	Left	Tilt	FI-095-B	6	0.003
5700	140	IEEE 802.11a	OFDM	12.60	0.00	Right	Touch	FI-095-B	6	0.227
5700	140	IEEE 802.11a	OFDM	12.60	0.06	Right	Tilt	FI-095-B	6	0.039
5700	140	IEEE 802.11a	OFDM	12.60	0.06	Left	Touch	FI-095-B	6	0.136
5700	140	IEEE 802.11a	OFDM	12.60	0.07	Left	Tilt	FI-095-B	6	0.036
5745	149	IEEE 802.11a	OFDM	12.42	-0.03	Right	Touch	FI-095-B	6	0.291
5745	149	IEEE 802.11a	OFDM	12.42	0.09	Right	Tilt	FI-095-B	6	0.037
5745	149	IEEE 802.11a	OFDM	12.42	0.00	Left	Touch	FI-095-B	6	0.192
5745	149	IEEE 802.11a	OFDM	12.42	0.06	Left	Tilt	FI-095-B	6	0.030
ANSI / IEEE C95.1 1992 - SAFETY LIMIT						Head				
Spatial Peak						1.6 W/kg (mW/g)				
Uncontrolled Exposure/General Population						averaged over 1 gram				

Notes:

1. The test data reported are the worst-case SAR value with the position set in a typical configuration. Test procedures used were according to FCC/OET Bulletin 65, Supplement C [June 2001].
2. All modes of operation were investigated, and worst-case results are reported.
3. Batteries are fully charged for all readings. Standard battery was used.
4. Tissue parameters and temperatures are listed on the SAR plots.
5. Liquid tissue depth was at least 15.0 cm.
6. Justification for reduced test configurations for WIFI channels per KDB Publication 248227 and April 2010 FCC/TCB Meeting Notes: For 5GHz, the highest average RF output power channel for the lowest data rate were selected for SAR evaluation. Other IEEE 802.11 modes (including 802.11n) were not investigated since the average output powers were not greater than 0.25 dB than that of the corresponding channel in the lowest data rate IEEE 802.11a mode.
7. WLAN transmission was verified using a spectrum analyzer.
8. All samples tested were electrically identical per the applicant.



FCC ID: A3LSWDSC02C	 PCTEST ENGINEERING LABORATORY, INC.	SAR COMPLIANCE REPORT		Reviewed by: Quality Manager
Filename: 0Y1104200782-R1.A3L	Test Dates: 05/02/11 - 05/04/11	EUT Type: 850/1900 GSM/GPRS/EDGE Phone with Bluetooth and WLAN		Page 27 of 45

**Table 15-4
2.4 GHz WLAN Head SAR Results**

MEASUREMENT RESULTS										
FREQUENCY		Mode	Service	Conducted Power [dBm]	Power Drift [dB]	Side	Test Position	Serial Number	Data Rate (Mbps)	SAR (1g)
MHz	Ch.									(W/kg)
2462	11	IEEE 802.11b	DSSS	17.22	0.08	Right	Touch	FI-095-A	1	0.073
2462	11	IEEE 802.11b	DSSS	17.22	0.04	Right	Tilt	FI-095-A	1	0.038
2462	11	IEEE 802.11b	DSSS	17.22	0.09	Left	Touch	FI-095-A	1	0.104
2462	11	IEEE 802.11b	DSSS	17.22	0.07	Left	Tilt	FI-095-A	1	0.018
ANSI / IEEE C95.1 1992 - SAFETY LIMIT Spatial Peak Uncontrolled Exposure/General Population						Head 1.6 W/kg (mW/g) averaged over 1 gram				

Notes:

1. The test data reported are the worst-case SAR value with the position set in a typical configuration. Test procedures used were according to FCC/OET Bulletin 65, Supplement C [June 2001].
2. All modes of operation were investigated, and worst-case results are reported.
3. Batteries are fully charged for all readings. Standard battery was used.
4. Tissue parameters and temperatures are listed on the SAR plots.
5. Liquid tissue depth was at least 15.0 cm.
6. Justification for reduced test configurations for WIFI channels per KDB Publication 248227 and April 2010 FCC/TCB Meeting Notes: For 2.4GHz, the highest average RF output power channel for the lowest data rate were selected for SAR evaluation. Other IEEE 802.11 modes (including 802.11n) were not investigated since the average output powers were not greater than 0.25 dB than that of the corresponding channel in the lowest data rate IEEE 802.11b mode.
7. WLAN transmission was verified using a spectrum analyzer.
8. All samples tested were electrically identical per the applicant.



FCC ID: A3LSWDSC02C	 PCTEST ENGINEERING LABORATORY, INC.	SAR COMPLIANCE REPORT		Reviewed by: Quality Manager
Filename: 0Y1104200782-R1.A3L	Test Dates: 05/02/11 - 05/04/11	EUT Type: 850/1900 GSM/GPRS/EDGE Phone with Bluetooth and WLAN		Page 28 of 45

**Table 15-5
Hotspot Body SAR Results**

MEASUREMENT RESULTS										
FREQUENCY		Mode	Service	Conducted Power [dBm]	Power Drift [dB]	Spacing	Serial Number	# of GPRS Slots	Side	SAR (1g)
MHz	Ch.									(W/kg)
836.60	190	GSM 850	GPRS	30.34	0.01	1.0 cm	FI-095-A	2	back	0.634
836.60	190	GSM 850	GPRS	28.94	0.01	1.0 cm	FI-095-A	3	back	0.693
836.60	190	GSM 850	GPRS	27.34	0.01	1.0 cm	FI-095-A	4	back	0.636
836.60	190	GSM 850	GPRS	28.94	0.00	1.0 cm	FI-095-A	3	front	0.511
836.60	190	GSM 850	GPRS	28.94	-0.01	1.0 cm	FI-095-A	3	bottom	0.258
836.60	190	GSM 850	GPRS	28.94	0.01	1.0 cm	FI-095-A	3	right	0.640
1880.00	661	GSM 1900	GPRS	28.81	-0.01	1.0 cm	FI-095-A	2	back	0.690
1880.00	661	GSM 1900	GPRS	26.82	0.00	1.0 cm	FI-095-A	3	back	0.650
1880.00	661	GSM 1900	GPRS	25.72	0.01	1.0 cm	FI-095-A	4	back	0.674
1880.00	661	GSM 1900	GPRS	28.81	0.03	1.0 cm	FI-095-A	2	front	0.235
1880.00	661	GSM 1900	GPRS	28.81	0.01	1.0 cm	FI-095-A	2	bottom	0.510
1880.00	661	GSM 1900	GPRS	28.81	0.01	1.0 cm	FI-095-A	2	right	0.215
ANSI / IEEE C95.1 1992 - SAFETY LIMIT						Body				
Spatial Peak						1.6 W/kg (mW/g)				
Uncontrolled Exposure/General Population						averaged over 1 gram				

Notes:

- The test data reported are the worst-case SAR value with the position set in a typical configuration. Test procedures used were according to FCC/OET Bulletin 65, Supplement C [June 2001].
- All modes of operation were investigated, and worst-case results are reported.
- Tissue parameters and temperatures are listed on the SAR plots.
- Batteries are fully charged for all readings. Standard battery was used.
- Liquid tissue depth was at least 15.0 cm.
- Device was tested using a fixed spacing.
- Justification for reduced test configurations per KDB Publication 941225: The source-based time-averaged output power was evaluated for all multi-slot operations. In addition to the worst-case reported, all source-based time-averaged powers within 10% of the worst-case were additionally included in the evaluation.
- Justification for reduced test configurations: Per FCC/OET Bulletin 65 Supplement C (June 2001) and Public Notice DA-02-1438, if the SAR measured at the middle channel for each test configuration is at least 3.0 dB lower than the SAR limit, testing at the high and low channels is optional for such test configuration(s).
- All samples tested were electrically identical per the applicant.
- Top and Left Edges were not tested since the antenna distance from the edge was greater than 2.5 cm per FCC KDB Publication 941225 D06 guidance (see Section 13).
- SAR evaluation requires a single frequency of measurement for valid measurements using the SAR probe and tissue calibrated which are calibrated for specific limited frequency ranges. Therefore, during SAR evaluation it was ensured that the WIFI transmission was disabled by the manufacturer to assess the standalone SAR to be evaluated for SAR. WIFI SAR was separately evaluated to account for the WIFI SAR for portable hotspot exposure conditions (See Section 13).



FCC ID: A3LSWDSC02C	 PCTEST ENGINEERING LABORATORY, INC.	SAR COMPLIANCE REPORT		Reviewed by: Quality Manager
Filename: 0Y1104200782-R1.A3L	Test Dates: 05/02/11 - 05/04/11	EUT Type: 850/1900 GSM/GPRS/EDGE Phone with Bluetooth and WLAN		Page 29 of 45

**Table 15-6
Hotspot 2.4 GHz Body SAR Results**

MEASUREMENT RESULTS										
FREQUENCY		Mode	Service	Conducted Power [dBm]	Power Drift [dB]	Spacing	Serial Number	Data Rate (Mbps)	Side	SAR
MHz	Ch.									(W/kg)
2462	11	IEEE 802.11b	DSSS	17.22	-0.04	1.0 cm	FI-095-A	1	back	0.120
2462	11	IEEE 802.11b	DSSS	17.22	0.08	1.0 cm	FI-095-A	1	front	0.078
2462	11	IEEE 802.11b	DSSS	17.22	0.05	1.0 cm	FI-095-A	1	bottom	0.119
2462	11	IEEE 802.11b	DSSS	17.22	-0.08	1.0 cm	FI-095-A	1	left	0.085
ANSI / IEEE C95.1 1992 - SAFETY LIMIT						Body				
Spatial Peak						1.6 W/kg (mW/g)				
Uncontrolled Exposure/General Population						averaged over 1 gram				

Notes:

1. The test data reported are the worst-case SAR value with the position set in a typical configuration. Test procedures used were according to FCC/OET Bulletin 65, Supplement C [June 2001].
2. All modes of operation were investigated, and worst-case results are reported.
3. Batteries are fully charged for all readings. Standard battery was used.
4. Tissue parameters and temperatures are listed on the SAR plots.
5. Liquid tissue depth is was at least 15.0 cm.
6. Device was tested using a fixed spacing.
7. Justification for reduced test configurations for WIFI channels per KDB Publication 248227 and April 2010 FCC/TCB Meeting Notes: For 2.4 GHz, the highest average RF output power channel for the lowest data rate were selected for SAR evaluation. Other IEEE 802.11 modes (including 802.11n) were not investigated since the average output powers were not greater than 0.25 dB than that of the corresponding channel in the lowest data rate IEEE 802.11b mode.
8. WLAN transmission was verified using a spectrum analyzer.
9. All samples tested were electrically identical per the applicant.
10. Top and Right Edges were not tested since the antenna distance from the edge was greater than 2.5 cm per FCC KDB Publication 941225 D06 (see Section 13).



FCC ID: A3LSWDSC02C		SAR COMPLIANCE REPORT		Reviewed by: Quality Manager
Filename: 0Y1104200782-R1.A3L	Test Dates: 05/02/11 - 05/04/11	EUT Type: 850/1900 GSM/GPRS/EDGE Phone with Bluetooth and WLAN		Page 30 of 45

**Table 15-7
5 GHz Body-Worn SAR Results**

MEASUREMENT RESULTS										
FREQUENCY		Mode	Service	Conducted Power [dBm]	Power Drift [dB]	Spacing	Serial Number	Data Rate (Mbps)	Side	SAR (1g)
MHz	Ch.									(W/kg)
5180	36	IEEE 802.11a	OFDM	11.48	0.09	1.0 cm	FI-095-B	6	back	0.016
5260	52	IEEE 802.11a	OFDM	12.25	0.05	1.0 cm	FI-095-B	6	back	0.021
5700	140	IEEE 802.11a	OFDM	12.60	0.05	1.0 cm	FI-095-B	6	back	0.071
5745	149	IEEE 802.11a	OFDM	12.42	0.06	1.0 cm	FI-095-B	6	back	0.068
ANSI / IEEE C95.1 1992 - SAFETY LIMIT Spatial Peak Uncontrolled Exposure/General Population						Body 1.6 W/kg (mW/g) averaged over 1 gram				

Notes:

1. The test data reported are the worst-case SAR value with the position set in a typical configuration. Test procedures used were according to FCC/OET Bulletin 65, Supplement C [June 2001].
2. All modes of operation were investigated, and worst-case results are reported.
3. Batteries are fully charged for all readings. Standard battery was used.
4. Tissue parameters and temperatures are listed on the SAR plots.
5. Liquid tissue depth is was at least 15.0 cm.
6. Device was tested using a fixed spacing.
7. Justification for reduced test configurations for WIFI channels per KDB Publication 248227 and April 2010 FCC/TCB Meeting Notes: For 5GHz, the highest average RF output power channel for the lowest data rate were selected for SAR evaluation. Other IEEE 802.11 modes (including 802.11n) were not investigated since the average output powers were not greater than 0.25 dB than that of the corresponding channel in the lowest data rate IEEE 802.11a mode.
8. WLAN transmission was verified using a spectrum analyzer.
9. All samples tested were electrically identical per the applicant.
10. Hotspot mode is not supported with 5 GHz WLAN.
11. To confirm the proper SAR liquid depth for 5 GHz body tests, the z-axis plots from the system verification performed with the same liquid that was tested for 5GHz body SAR tests were included to confirm the liquid depth, since the measured SAR was low and could not be used to determine this requirement.

FCC ID: A3LSWDSC02C	 PCTEST ENGINEERING LABORATORY, INC.	SAR COMPLIANCE REPORT		Reviewed by: Quality Manager
Filename: 0Y1104200782-R1.A3L	Test Dates: 05/02/11 - 05/04/11	EUT Type: 850/1900 GSM/GPRS/EDGE Phone with Bluetooth and WLAN		Page 31 of 45

16 FCC MULTI-TX AND ANTENNA SAR CONSIDERATIONS

16.1 Introduction

The following procedures adopted from “FCC SAR Considerations for Cell Phones with Multiple Transmitters” FCC KDB Publication 648474 are applicable to handsets with built-in unlicensed transmitters such as 802.11 a/b/g and Bluetooth devices which may simultaneously transmit with the licensed transmitter.

16.2 FCC Power Tables & Conditions

	2.45	5.15 - 5.35	5.47 - 5.85	GHz
P_{Ref}	12	6	5	mW

Device output power should be rounded to the nearest mW to compare with values specified in this table.



Figure 16-1
Output Power Thresholds for Unlicensed Transmitters

	Individual Transmitter	Simultaneous Transmission
Licensed Transmitters	<u>Routine evaluation required</u>	SAR not required: <u>Unlicensed only</u>
Unlicensed Transmitters	<p>When there is no simultaneous transmission –</p> <ul style="list-style-type: none"> output $\leq 60/f$: SAR not required output $> 60/f$: stand-alone SAR required <p>When there is simultaneous transmission – <u>Stand-alone SAR not required when</u></p> <ul style="list-style-type: none"> output $\leq 2 \cdot P_{Ref}$ and antenna is ≥ 5.0 cm from other antennas output $\leq P_{Ref}$ and antenna is ≥ 2.5 cm from other antennas output $\leq P_{Ref}$ and antenna is < 2.5 cm from other antennas, each with either output power $\leq P_{Ref}$ or 1-g SAR < 1.2 W/kg <p><u>Otherwise stand-alone SAR is required</u></p> <p>When stand-alone SAR is required</p> <ul style="list-style-type: none"> test SAR on highest output channel for each wireless mode and exposure condition if SAR for highest output channel is $> 50\%$ of SAR limit, evaluate all channels according to normal procedures 	<ul style="list-style-type: none"> when stand-alone 1-g SAR is not required and antenna is ≥ 5 cm from other antennas <p><u>Licensed & Unlicensed</u></p> <ul style="list-style-type: none"> when the sum of the 1-g SAR is < 1.6 W/kg for all simultaneous transmitting antennas when SAR to peak location separation ratio of simultaneous transmitting antenna pair is < 0.3 <p>SAR required: <u>Licensed & Unlicensed</u></p> <p>antenna pairs with SAR to peak location separation ratio ≥ 0.3; test is only required for the configuration that results in the highest SAR in stand-alone configuration for each wireless mode and exposure condition</p> <p>Note: simultaneous transmission exposure conditions for head and body can be different for different style phones; therefore, different test requirements may apply</p>

Figure 16-2
SAR Evaluation Requirements for Multiple Transmitter Handsets

16.3 Multiple Antenna/Transmission Information

The separation between the main antenna and the Bluetooth and WLAN antennas is 19.1 mm. RF Conducted Power of Bluetooth Tx is 9.616 mW. RF Conducted Power of WLAN is 53.21 mW.

FCC ID: A3LSWDSC02C	 PCTEST ENGINEERING LABORATORY, INC.	SAR COMPLIANCE REPORT		Reviewed by: Quality Manager
Filename: 0Y1104200782-R1.A3L	Test Dates: 05/02/11 - 05/04/11	EUT Type: 850/1900 GSM/GPRS/EDGE Phone with Bluetooth and WLAN		Page 32 of 45

16.4 Simultaneous Transmission Analysis

Based on the output power, antenna separation distance and the Body SAR of the dominant transmitter, a stand-alone Bluetooth SAR test is not required while for WLAN it is required.

Table 16-1
Simultaneous Transmission Scenario (Held to Ear)

Simult Tx	Configuration	GSM 850 SAR (W/kg)	2.4 GHz WIFI SAR (W/kg)	Σ SAR (W/kg)	Simult Tx	Configuration	GSM 1900 SAR (W/kg)	2.4 GHz WIFI SAR (W/kg)	Σ SAR (W/kg)
Head SAR	Right Cheek	0.235	0.073	0.308	Head SAR	Right Cheek	0.071	0.073	0.144
	Right Tilt	0.153	0.038	0.191		Right Tilt	0.020	0.038	0.059
	Left Cheek	0.207	0.104	0.311		Left Cheek	0.087	0.104	0.191
	Left Tilt	0.133	0.018	0.151		Left Tilt	0.024	0.018	0.042
Simult Tx	Configuration	GSM 850 SAR (W/kg)	5 GHz WIFI SAR (W/kg)	Σ SAR (W/kg)	Simult Tx	Configuration	GSM 1900 SAR (W/kg)	5 GHz WIFI SAR (W/kg)	Σ SAR (W/kg)
Head SAR	Right Cheek	0.235	0.291	0.526	Head SAR	Right Cheek	0.071	0.291	0.362
	Right Tilt	0.153	0.039	0.192		Right Tilt	0.020	0.039	0.060
	Left Cheek	0.207	0.192	0.399		Left Cheek	0.087	0.192	0.279
	Left Tilt	0.133	0.036	0.169		Left Tilt	0.024	0.036	0.061

Table 16-2
2.4 GHz Simultaneous Transmission Scenario (Hotspot)

Simult Tx	Configuration	GPRS 850 SAR (W/kg)	2.4 GHz WIFI SAR (W/kg)	Σ SAR (W/kg)	Simult Tx	Configuration	GPRS 1900 SAR (W/kg)	2.4 GHz WIFI SAR (W/kg)	Σ SAR (W/kg)
Body SAR	Back	0.693	0.120	0.813	Body SAR	Back	0.690	0.120	0.810
	Front	0.511	0.078	0.589		Front	0.235	0.078	0.313
	Top	0.000	0.000	0.000		Top	0.000	0.000	0.000
	Bottom	0.258	0.119	0.377		Bottom	0.510	0.119	0.629
	Right	0.640	0.000	0.640		Right	0.215	0.000	0.215
	Left	0.000	0.085	0.085		Left	0.000	0.085	0.085

Edges more than 2.5 cm from an antenna were not required to be tested per FCC KDB Publication 941225 D06 and are 0 W/kg for summation analysis (see Section 13).



Table 16-3
5GHz Simultaneous Transmission Scenario (Body-Worn at 1.0 cm)

Configuration	Mode	2G/3G SAR (W/kg)	5 GHz WIFI SAR (W/kg)	Σ SAR (W/kg)
Back Side	GPRS 850	0.693	0.071	0.764
Back Side	GPRS 1900	0.690	0.071	0.761

Hotspot is not supported for 5GHz WLAN.



16.5 Simultaneous Transmission Conclusion

The above numerical summed SAR was below the SAR limit. Therefore, the above analysis is sufficient to determine that simultaneous transmission cases will not exceed the SAR limit. Therefore, no volumetric SAR summation is required per FCC KDB Publication 648474.

FCC ID: A3LSWDSC02C	 PCTEST ENGINEERING LABORATORY, INC.	SAR COMPLIANCE REPORT		Reviewed by: Quality Manager
Filename: 0Y1104200782-R1.A3L	Test Dates: 05/02/11 - 05/04/11	EUT Type: 850/1900 GSM/GPRS/EDGE Phone with Bluetooth and WLAN		Page 33 of 45

17 EQUIPMENT LIST

Manufacturer	Model	Description	Cal Date	Cal Interval	Cal Due	Serial Number
Agilent	85070B	Dielectric Probe Kit	8/22/2010	Annual	8/22/2011	US33020316
Agilent	8648D	(9kHz-4GHz) Signal Generator	10/13/2010	Annual	10/13/2011	3613A00315
Agilent	8753E	(30kHz-6GHz) Network Analyzer	4/21/2011	Annual	4/21/2012	JP38020182
Agilent	E5515C	Wireless Communications Test Set	10/11/2010	Annual	10/11/2011	GB46110872
Agilent	E5515C	Wireless Communications Test Set	10/8/2010	Annual	10/8/2011	GB46310798
Agilent	E5515C	Wireless Communications Test Set	8/13/2010	Annual	8/13/2011	GB41450275
Agilent	E8257D	(250kHz-20GHz) Signal Generator	4/8/2011	Annual	4/8/2012	MY45470194
Gigatronics	80701A	(0.05-18GHz) Power Sensor	10/11/2010	Annual	10/11/2011	1833460
Gigatronics	8651A	Universal Power Meter	10/11/2010	Annual	10/11/2011	8650319
Index SAR	IXTL-010	Dielectric Measurement Kit	N/A		N/A	N/A
Index SAR	IXTL-030	30MM TEM line for 6 GHz	N/A		N/A	N/A
Pasternack	PE2208-6	Bidirectional Coupler	N/A		N/A	N/A
Pasternack	PE2209-10	Bidirectional Coupler	N/A		N/A	N/A
Rohde & Schwarz	CMU200	Base Station Simulator	11/11/2010	Annual	11/11/2011	836371/0079
Rohde & Schwarz	CMU200	Base Station Simulator	6/21/2010	Annual	6/21/2011	833855/0010
Rohde & Schwarz	NRVD	Dual Channel Power Meter	4/8/2011	Biennial	4/8/2013	101695
SPEAG	D1450V2	1450 MHz SAR Dipole	5/20/2009	Biennial	5/20/2011	1025
SPEAG	D1765V2	1765 MHz SAR Dipole	5/19/2009	Biennial	5/19/2011	1008
SPEAG	D1900V2	1900 MHz SAR Dipole	2/17/2011	Annual	2/17/2012	502
SPEAG	D1900V2	1900 MHz SAR Dipole	8/18/2009	Biennial	8/18/2011	5d080
SPEAG	D2450V2	2450 MHz SAR Dipole	8/27/2009	Biennial	8/27/2011	719
SPEAG	D2450V2	2450 MHz SAR Dipole	2/8/2011	Annual	2/8/2012	797
SPEAG	D2600V2	2600 MHz SAR Dipole	4/15/2011	Biennial	4/15/2013	1004
SPEAG	D5GHzV2	5 GHz SAR Dipole	8/19/2009	Biennial	8/19/2011	1007
SPEAG	D5GHzV2	5 GHz SAR Dipole	2/11/2011	Annual	2/11/2012	1057
SPEAG	D835V2	835 MHz SAR Dipole	2/9/2011	Annual	2/9/2012	4d047
SPEAG	D835V2	835 MHz SAR Dipole	8/24/2009	Biennial	8/24/2011	4d026
SPEAG	DAE3	Dasy Data Acquisition Electronics	11/18/2010	Annual	11/18/2011	455
SPEAG	DAE4	Dasy Data Acquisition Electronics	3/17/2011	Annual	3/17/2012	704
SPEAG	DAE4	Dasy Data Acquisition Electronics	4/20/2011	Annual	4/20/2012	665
SPEAG	DAE4	Dasy Data Acquisition Electronics	2/21/2011	Annual	2/21/2012	649
SPEAG	E53DV2	SAR Probe	9/21/2010	Annual	9/21/2011	3022
SPEAG	EX3DV4	SAR Probe	8/19/2010	Annual	8/19/2011	3561
SPEAG	EX3DV4	SAR Probe	2/14/2011	Annual	2/14/2012	3550
SPEAG	DAE4	Dasy Data Acquisition Electronics	7/8/2010	Annual	7/8/2011	859
SPEAG	D750V3	750 MHz Dipole	2/14/2011	Annual	2/14/2012	1003
SPEAG	E53DV3	SAR Probe	3/24/2011	Annual	3/24/2012	3213
SPEAG	E53DV3	SAR Probe	4/18/2011	Annual	4/18/2012	3209
Rohde & Schwarz	SMIQ03B	Signal Generator	4/6/2011	Annual	4/6/2012	DE27259
SPEAG	D1640V2	1640 MHz Dipole	8/17/2010	Biennial	8/17/2012	321
Rohde & Schwarz	CMW500	LTE Radio Communication Tester	8/30/2010	Annual	8/30/2011	100976
Anritsu	MA2481A	Power Sensor	2/7/2011	Annual	2/7/2012	5318
Anritsu	MA2481A	Power Sensor	2/7/2011	Annual	2/7/2012	5442
Anritsu	ML2438A	Power Meter	2/7/2011	Annual	2/7/2012	1190013
Anritsu	ML2438A	Power Meter	2/7/2011	Annual	2/7/2012	98150041
Agilent	8648D	Signal Generator	4/5/2011	Annual	4/5/2012	3629U00687
Anritsu	ML2438A	Power Meter	2/7/2011	Annual	2/7/2012	1070030
Anritsu	MA2481A	Power Sensor	2/7/2011	Annual	2/7/2012	5821
Anritsu	MA2481A	Power Sensor	2/7/2011	Annual	2/7/2012	8013
Anritsu	MA2481A	Power Sensor	2/7/2011	Annual	2/7/2012	2400
Apriel	ALS-PR-DIEL	Dielectric Probe Kit	N/A		N/A	260-00959
Agilent	E5515C	Wireless Communications Test Set	8/13/2010	Annual	8/13/2011	GB43304447
Agilent	E5515C	Wireless Communications Tester	4/21/2011	Annual	4/21/2012	US41140256
Amplifier Research	5S1G4	5W, 800MHz-4.2GHz	N/A			17042
Mini-Circuits	BW-N20W5+	DC to 18 GHz Precision Fixed 20 dB Attenuator	N/A			N/A
Agilent	E5515C	Wireless Communications Test Set	2/8/2011	Annual	2/8/2012	GB45360985
Speag	D3700V2	3700 MHz SAR Dipole	2/16/2011	Annual	2/16/2012	1002
Rohde & Schwarz	CMW500	LTE Radio Communication Tester	3/11/2011	Annual	3/11/2012	103962
Control Company	61220-416	Long-Stem Thermometer	2/15/2011	Biennial	2/15/2013	111331322
Control Company	61220-416	Long-Stem Thermometer	2/15/2011	Biennial	2/15/2013	111331323
Control Company	61220-416	Long-Stem Thermometer	2/15/2011	Biennial	2/15/2013	111331330
Control Company	61220-416	Long-Stem Thermometer	2/15/2011	Biennial	2/15/2013	111331332
Control Company	61220-416	Long-Stem Thermometer	3/16/2011	Biennial	3/16/2013	111391601



FCC ID: A3LSWDSC02C	 PCTEST Engineering Laboratory, Inc.	SAR COMPLIANCE REPORT		Reviewed by: Quality Manager
Filename: 0Y1104200782-R1.A3L	Test Dates: 05/02/11 - 05/04/11	EUT Type: 850/1900 GSM/GPRS/EDGE Phone with Bluetooth and WLAN		Page 34 of 45

18 MEASUREMENT UNCERTAINTIES

Applicable for 800 – 3000 MHz.

a	b	c	d	e= f(d,k)	f	g	h = c x f/e	i = c x g/e	k
Uncertainty Component	IEEE 1528 Sec.	Tol. (± %)	Prob. Dist.	Div.	c _i 1gm	c _i 10 gms	1gm u _i (± %)	10gms u _i (± %)	v _i
Measurement System									
Probe Calibration	E.2.1	5.5	N	1	1.0	1.0	5.5	5.5	∞
Axial Isotropy	E.2.2	0.25	N	1	0.7	0.7	0.2	0.2	∞
Hemishperical Isotropy	E.2.2	1.3	N	1	1.0	1.0	1.3	1.3	∞
Boundary Effect	E.2.3	0.4	N	1	1.0	1.0	0.4	0.4	∞
Linearity	E.2.4	0.3	N	1	1.0	1.0	0.3	0.3	∞
System Detection Limits	E.2.5	5.1	N	1	1.0	1.0	5.1	5.1	∞
Readout Electronics	E.2.6	1.0	N	1	1.0	1.0	1.0	1.0	∞
Response Time	E.2.7	0.8	R	1.73	1.0	1.0	0.5	0.5	∞
Integration Time	E.2.8	2.6	R	1.73	1.0	1.0	1.5	1.5	∞
RF Ambient Conditions	E.6.1	3.0	R	1.73	1.0	1.0	1.7	1.7	∞
Probe Positioner Mechanical Tolerance	E.6.2	0.4	R	1.73	1.0	1.0	0.2	0.2	∞
Probe Positioning w/ respect to Phantom	E.6.3	2.9	R	1.73	1.0	1.0	1.7	1.7	∞
Extrapolation, Interpolation & Integration algorithms for Max. SAR Evaluation	E.5	1.0	R	1.73	1.0	1.0	0.6	0.6	∞
Test Sample Related									
Test Sample Positioning	E.4.2	6.0	N	1	1.0	1.0	6.0	6.0	287
Device Holder Uncertainty	E.4.1	3.32	R	1.73	1.0	1.0	1.9	1.9	∞
Output Power Variation - SAR drift measurement	6.6.2	5.0	R	1.73	1.0	1.0	2.9	2.9	∞
Phantom & Tissue Parameters									
Phantom Uncertainty (Shape & Thickness tolerances)	E.3.1	4.0	R	1.73	1.0	1.0	2.3	2.3	∞
Liquid Conductivity - deviation from target values	E.3.2	5.0	R	1.73	0.64	0.43	1.8	1.2	∞
Liquid Conductivity - measurement uncertainty	E.3.3	3.8	N	1	0.64	0.43	2.4	1.6	6
Liquid Permittivity - deviation from target values	E.3.2	5.0	R	1.73	0.60	0.49	1.7	1.4	∞
Liquid Permittivity - measurement uncertainty	E.3.3	4.5	N	1	0.60	0.49	2.7	2.2	6
Combined Standard Uncertainty (k=1)				RSS			11.8	11.5	299
Expanded Uncertainty (95% CONFIDENCE LEVEL)				k=2			23.7	23.0	



The above measurement uncertainties are according to IEEE Std. 1528-2003

FCC ID: A3LSWDSC02C	 PCTEST ENGINEERING LABORATORY, INC.	SAR COMPLIANCE REPORT		Reviewed by: Quality Manager
Filename: 0Y1104200782-R1.A3L	Test Dates: 05/02/11 - 05/04/11	EUT Type: 850/1900 GSM/GPRS/EDGE Phone with Bluetooth and WLAN		Page 35 of 45

Applicable for 5GHz.

a	b	c	d	e= f(d,k)	f	g	h = c x f/e	i = c x g/e	k	
Uncertainty Component	IEEE 1528 Sec.	Tol. (± %)	Prob. Dist.	Div.	c _i 1gm	c _i 10 gms	1gm u _i (± %)	10gms u _i (± %)	v _i	
Measurement System										
Probe Calibration	E.2.1	6.55	N	1	1.0	1.0	6.6	6.6	∞	
Axial Isotropy	E.2.2	0.25	N	1	0.7	0.7	0.2	0.2	∞	
Hemishperical Isotropy	E.2.2	1.3	N	1	1.0	1.0	1.3	1.3	∞	
Boundary Effect	E.2.3	0.4	N	1	1.0	1.0	0.4	0.4	∞	
Linearity	E.2.4	0.3	N	1	1.0	1.0	0.3	0.3	∞	
System Detection Limits	E.2.5	5.1	N	1	1.0	1.0	5.1	5.1	∞	
Readout Electronics	E.2.6	1.0	N	1	1.0	1.0	1.0	1.0	∞	
Response Time	E.2.7	0.8	R	1.73	1.0	1.0	0.5	0.5	∞	
Integration Time	E.2.8	2.6	R	1.73	1.0	1.0	1.5	1.5	∞	
RF Ambient Conditions	E.6.1	3.0	R	1.73	1.0	1.0	1.7	1.7	∞	
Probe Positioner Mechanical Tolerance	E.6.2	0.4	R	1.73	1.0	1.0	0.2	0.2	∞	
Probe Positioning w/ respect to Phantom	E.6.3	2.9	R	1.73	1.0	1.0	1.7	1.7	∞	
Extrapolation, Interpolation & Integration algorithms for Max. SAR Evaluation	E.5	1.0	R	1.73	1.0	1.0	0.6	0.6	∞	
Test Sample Related										
Test Sample Positioning	E.4.2	6.0	N	1	1.0	1.0	6.0	6.0	287	
Device Holder Uncertainty	E.4.1	3.32	R	1.73	1.0	1.0	1.9	1.9	∞	
Output Power Variation - SAR drift measurement	6.6.2	5.0	R	1.73	1.0	1.0	2.9	2.9	∞	
Phantom & Tissue Parameters										
Phantom Uncertainty (Shape & Thickness tolerances)	E.3.1	4.0	R	1.73	1.0	1.0	2.3	2.3	∞	
Liquid Conductivity - deviation from target values	E.3.2	5.0	R	1.73	0.64	0.43	1.8	1.2	∞	
Liquid Conductivity - measurement uncertainty	E.3.3	3.8	N	1	0.64	0.43	2.4	1.6	6	
Liquid Permittivity - deviation from target values	E.3.2	5.0	R	1.73	0.60	0.49	1.7	1.4	∞	
Liquid Permittivity - measurement uncertainty	E.3.3	4.5	N	1	0.60	0.49	2.7	2.2	6	
Combined Standard Uncertainty (k=1)							RSS	12.4	12.0	299
Expanded Uncertainty (95% CONFIDENCE LEVEL)							k=2	24.7	24.0	

The above measurement uncertainties are according to IEEE Std. 1528-2003



FCC ID: A3LSWDSC02C	 PCTEST ENGINEERING LABORATORY, INC.	SAR COMPLIANCE REPORT		Reviewed by: Quality Manager
Filename: 0Y1104200782-R1.A3L	Test Dates: 05/02/11 - 05/04/11	EUT Type: 850/1900 GSM/GPRS/EDGE Phone with Bluetooth and WLAN		Page 36 of 45

19 CONCLUSION



19.1 Measurement Conclusion

The SAR evaluation indicates that the EUT complies with the RF radiation exposure limits of the FCC and Industry Canada, with respect to all parameters subject to this test. These measurements were taken to simulate the RF effects of RF exposure under worst-case conditions. Precise laboratory measures were taken to assure repeatability of the tests. The results and statements relate only to the item(s) tested.



Please note that the absorption and distribution of electromagnetic energy in the body are very complex phenomena that depend on the mass, shape, and size of the body, the orientation of the body with respect to the field vectors, and the electrical properties of both the body and the environment. Other variables that may play a substantial role in possible biological effects are those that characterize the environment (e.g. ambient temperature, air velocity, relative humidity, and body insulation) and those that characterize the individual (e.g. age, gender, activity level, debilitation, or disease). Because various factors may interact with one another to vary the specific biological outcome of an exposure to electromagnetic fields, any protection guide should consider maximal amplification of biological effects as a result of field-body interactions, environmental conditions, and physiological variables. [3]

FCC ID: A3LSWDSC02C		SAR COMPLIANCE REPORT		Reviewed by: Quality Manager
Filename: 0Y1104200782-R1.A3L	Test Dates: 05/02/11 - 05/04/11	EUT Type: 850/1900 GSM/GPRS/EDGE Phone with Bluetooth and WLAN		Page 37 of 45

- [1] Federal Communications Commission, ET Docket 93-62, Guidelines for Evaluating the Environmental Effects of Radiofrequency Radiation, Aug. 1996.
- [2] ANSI/IEEE C95.1-2005, American National Standard safety levels with respect to human exposure to radio frequency electromagnetic fields, 300kHz to 100GHz, New York: IEEE, 2006.
- [3] ANSI/IEEE C95.1-1992, American National Standard safety levels with respect to human exposure to radio frequency electromagnetic fields, 300kHz to 100GHz, New York: IEEE, Sept. 1992.
- [4] ANSI/IEEE C95.3-2002, IEEE Recommended Practice for the Measurement of Potentially Hazardous Electromagnetic Fields - RF and Microwave, New York: IEEE, December 2002.
- [5] Federal Communications Commission, OET Bulletin 65 (Edition 97-01), Supplement C (Edition 01-01), Evaluating Compliance with FCC Guidelines for Human Exposure to Radiofrequency Electromagnetic Fields, June 2001.
- [6] IEEE Standards Coordinating Committee 34 – IEEE Std. 1528-2003, Recommended Practice for Determining the Peak Spatial-Average Specific Absorption Rate (SAR) in the Human Body Due to Wireless Communications Devices.
- [7] NCRP, National Council on Radiation Protection and Measurements, Biological Effects and Exposure Criteria for RadioFrequency Electromagnetic Fields, NCRP Report No. 86, 1986. Reprinted Feb. 1995.
- [8] T. Schmid, O. Egger, N. Kuster, Automated E-field scanning system for dosimetric assessments, IEEE Transaction on Microwave Theory and Techniques, vol. 44, Jan. 1996, pp. 105-113.
- [9] K. Pokovic, T. Schmid, N. Kuster, Robust setup for precise calibration of E-field probes in tissue simulating liquids at mobile communications frequencies, ICECOM97, Oct. 1997, pp. 120-124.
- [10] K. Pokovic, T. Schmid, and N. Kuster, E-field Probe with improved isotropy in brain simulating liquids, Proceedings of the ELMAR, Zadar, Croatia, June 23-25, 1996, pp. 172-175.
- [11] Schmid & Partner Engineering AG, Application Note: Data Storage and Evaluation, June 1998, p2.
- [12] V. Hombach, K. Meier, M. Burkhardt, E. Kuhn, N. Kuster, The Dependence of EM Energy Absorption upon Human Head Modeling at 900 MHz, IEEE Transaction on Microwave Theory and Techniques, vol. 44 no. 10, Oct. 1996, pp. 1865-1873.
- [13] N. Kuster and Q. Balzano, Energy absorption mechanism by biological bodies in the near field of dipole antennas above 300MHz, IEEE Transaction on Vehicular Technology, vol. 41, no. 1, Feb. 1992, pp. 17-23.
- [14] G. Hartsgrrove, A. Kraszewski, A. Surowiec, Simulated Biological Materials for Electromagnetic Radiation Absorption Studies, University of Ottawa, Bioelectromagnetics, Canada: 1987, pp. 29-36.
- [15] Q. Balzano, O. Garay, T. Manning Jr., Electromagnetic Energy Exposure of Simulated Users of Portable Cellular Telephones, IEEE Transactions on Vehicular Technology, vol. 44, no.3, Aug. 1995.
- [16] W. Gander, Computermathematik, Birkhaeuser, Basel, 1992.
- [17] W.H. Press, S.A. Teukolsky, W.T. Vetterling, and B.P. Flannery, Numerical Recipes in C, The Art of Scientific Computing, Second edition, Cambridge University Press, 1992.

FCC ID: A3LSWDSC02C		SAR COMPLIANCE REPORT		Reviewed by: Quality Manager
Filename: 0Y1104200782-R1.A3L	Test Dates: 05/02/11 - 05/04/11	EUT Type: 850/1900 GSM/GPRS/EDGE Phone with Bluetooth and WLAN	Page 38 of 45	

- [18] Federal Communications Commission, OET Bulletin 65, Evaluating Compliance with FCC Guidelines for Human Exposure to Radiofrequency Electromagnetic Fields. Supplement C, Dec. 1997.
- [19] N. Kuster, R. Kastle, T. Schmid, Dosimetric evaluation of mobile communications equipment with known precision, IEEE Transaction on Communications, vol. E80-B, no. 5, May 1997, pp. 645-652.
- [20] CENELEC CLC/SC111B, European Prestandard (prENV 50166-2), Human Exposure to Electromagnetic Fields High-frequency: 10kHz-300GHz, Jan. 1995.
- [21] Prof. Dr. Niels Kuster, ETH, Eidgenössische Technische Hochschule Zürich, Dosimetric Evaluation of the Cellular Phone.
- [22] IEC 62209-1, Human exposure to radio frequency fields from hand-held and body-mounted wireless communication devices - Human models, instrumentation, and procedures - Part 1: Procedure to determine the specific absorption rate (SAR) for hand-held devices used in close proximity to the ear (frequency range of 300 MHz to 3 GHz), Feb. 2005.
- [23] Industry Canada RSS-102 Radio Frequency Exposure Compliance of Radiocommunication Apparatus (All Frequency Bands) Issue 4, March 2010.
- [24] Health Canada Safety Code 6 Limits of Human Exposure to Radio Frequency Electromagnetic Fields in the Frequency Range from 3 kHz – 300 GHz, 2009
- [25] FCC Public Notice DA-02-1438. Office of Engineering and Technology Announces a Transition Period for the Phantom Requirements of Supplement C to OET Bulletin 65, June 19, 2002
- [26] FCC SAR Measurement Procedures for 3G Devices KDB Publication 941225
- [27] SAR Measurement procedures for IEEE 802.11a/b/g KDB Publication 248227
- [28] FCC SAR Considerations for Handsets with Multiple Transmitters and Antennas, KDB Publication 648474
- [29] FCC Application Note for SAR Probe Calibration and System Verification Consideration for Measurements at 150 MHz – 3 GHz, KDB Publication 450824
- [30] FCC SAR Evaluation Considerations for Laptop Computers with Antennas Built-in on Display Screens, KDB Publication 616217
- [31] FCC SAR Measurement Requirements for 3 – 6 GHz, KDB Publication 865664
- [32] FCC Mobile Portable RF Exposure Procedure, KDB Publication 447498
- [33] FCC SAR Procedures for Dongle Transmitters, KDB Publication 447498
- [34] Anexo à Resolução No. 533, de 10 de Setembro de 2009.
- [35] FCC SAR Test Considerations for LTE Handsets and Data Modems, KDB Publication 941225.
- [36] IEC 62209-2, Human exposure to radio frequency fields from hand-held and body-mounted wireless communication devices - Human models, instrumentation, and procedures - Part 2: Procedure to determine the specific absorption rate (SAR) for wireless communication devices used in close proximity to the human body (frequency range of 30 MHz to 6 GHz), Mar. 2010.
- [37] FCC D06 Hot Spot SAR v01, KDB Publication 941225.

FCC ID: A3LSWDSC02C		SAR COMPLIANCE REPORT		Reviewed by: Quality Manager
Filename: 0Y1104200782-R1.A3L	Test Dates: 05/02/11 - 05/04/11	EUT Type: 850/1900 GSM/GPRS/EDGE Phone with Bluetooth and WLAN	Page 39 of 45	

APPENDIX A: SAR TEST DATA

PCTEST ENGINEERING LABORATORY, INC.

**DUT: A3LSWDSC02C; Type: 850/1900 GSM/GPRS/EDGE Phone with Bluetooth and WLAN
Serial: FI-095-A**

Communication System: GSM850; Frequency: 836.6 MHz; Duty Cycle: 1:8.3
Medium: 835 Head; Medium parameters used (interpolated):
 $f = 836.6 \text{ MHz}$; $\sigma = 0.867 \text{ mho/m}$; $\epsilon_r = 39.99$; $\rho = 1000 \text{ kg/m}^3$
Phantom section: Right Section

Test Date: 05-04-2011; Ambient Temp: 24.0°C; Tissue Temp: 22.6°C

Probe: EX3DV4 - SN3561; ConvF(7.96, 7.96, 7.96); Calibrated: 8/19/2010
Sensor-Surface: 4mm (Mechanical Surface Detection)
Electronics: DAE4 Sn649; Calibrated: 2/21/2011
Phantom: SAM Sub; Type: SAM 4.0; Serial: TP-1357
Measurement SW: DASY4, V4.7 Build 80; Postprocessing SW: SEMCAD, V1.8 Build 186

Mode: GSM 850, Right Head, Touch, Mid.ch

Area Scan (7x14x1): Measurement grid: dx=15mm, dy=15mm
Zoom Scan (5x5x7)/Cube 0: Measurement grid: dx=8mm, dy=8mm, dz=5mm
Reference Value = 16.8 V/m
Peak SAR (extrapolated) = 0.300 W/kg
SAR(1 g) = 0.235 mW/g; SAR(10 g) = 0.177 mW/g

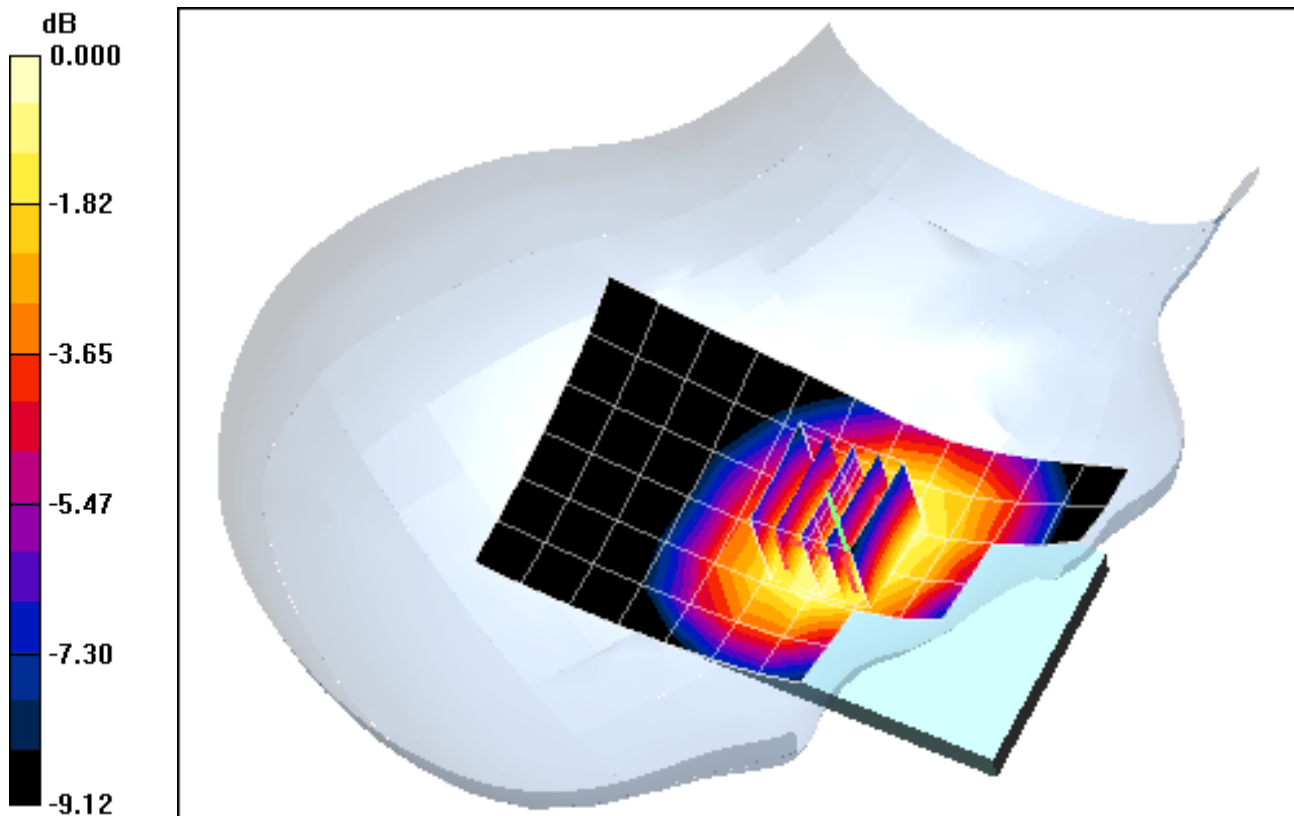

0 dB = 0.247mW/g

PCTEST ENGINEERING LABORATORY, INC.

**DUT: A3LSWDSC02C; Type: 850/1900 GSM/GPRS/EDGE Phone with Bluetooth and WLAN
Serial: FI-095-A**

Communication System: GSM850; Frequency: 836.6 MHz; Duty Cycle: 1:8.3
Medium: 835 Head; Medium parameters used (interpolated):
 $f = 836.6 \text{ MHz}$; $\sigma = 0.867 \text{ mho/m}$; $\epsilon_r = 39.99$; $\rho = 1000 \text{ kg/m}^3$
Phantom section: Right Section

Test Date: 05-04-2011; Ambient Temp: 24.0°C; Tissue Temp: 22.6°C

Probe: EX3DV4 - SN3561; ConvF(7.96, 7.96, 7.96); Calibrated: 8/19/2010
Sensor-Surface: 4mm (Mechanical Surface Detection)
Electronics: DAE4 Sn649; Calibrated: 2/21/2011
Phantom: SAM Sub; Type: SAM 4.0; Serial: TP-1357
Measurement SW: DASY4, V4.7 Build 80; Postprocessing SW: SEMCAD, V1.8 Build 186

Mode: GSM 850, Right Head, Touch, Mid.ch

Area Scan (7x14x1): Measurement grid: dx=15mm, dy=15mm
Zoom Scan (5x5x7)/Cube 0: Measurement grid: dx=8mm, dy=8mm, dz=5mm
Reference Value = 16.8 V/m
Peak SAR (extrapolated) = 0.300 W/kg
SAR(1 g) = 0.235 mW/g; SAR(10 g) = 0.177 mW/g

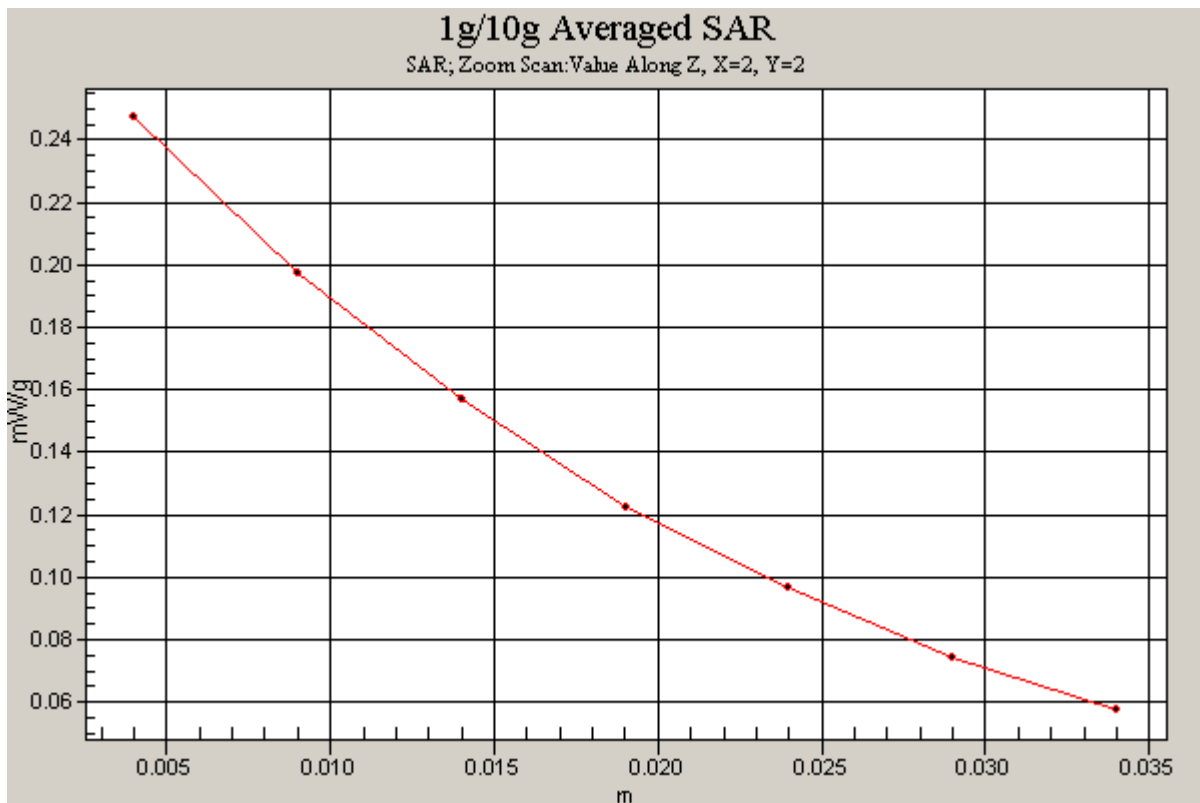

PCTEST ENGINEERING LABORATORY, INC.

**DUT: A3LSWDSC02C; Type: 850/1900 GSM/GPRS/EDGE Phone with Bluetooth and WLAN
Serial: FI-095-A**

Communication System: GSM850; Frequency: 836.6 MHz; Duty Cycle: 1:8.3
Medium: 835 Head; Medium parameters used (interpolated):
 $f = 836.6 \text{ MHz}$; $\sigma = 0.867 \text{ mho/m}$; $\epsilon_r = 39.99$; $\rho = 1000 \text{ kg/m}^3$
Phantom section: Right Section

Test Date: 05-04-2011; Ambient Temp: 24.0°C; Tissue Temp: 22.6°C

Probe: EX3DV4 - SN3561; ConvF(7.96, 7.96, 7.96); Calibrated: 8/19/2010
Sensor-Surface: 4mm (Mechanical Surface Detection)
Electronics: DAE4 Sn649; Calibrated: 2/21/2011
Phantom: SAM Sub; Type: SAM 4.0; Serial: TP-1357
Measurement SW: DASY4, V4.7 Build 80; Postprocessing SW: SEMCAD, V1.8 Build 186

Mode: GSM 850, Right Head, Tilt, Mid.ch

Area Scan (7x14x1): Measurement grid: dx=15mm, dy=15mm
Zoom Scan (5x5x7)/Cube 0: Measurement grid: dx=8mm, dy=8mm, dz=5mm
Reference Value = 13.4 V/m
Peak SAR (extrapolated) = 0.189 W/kg
SAR(1 g) = 0.153 mW/g; SAR(10 g) = 0.118 mW/g

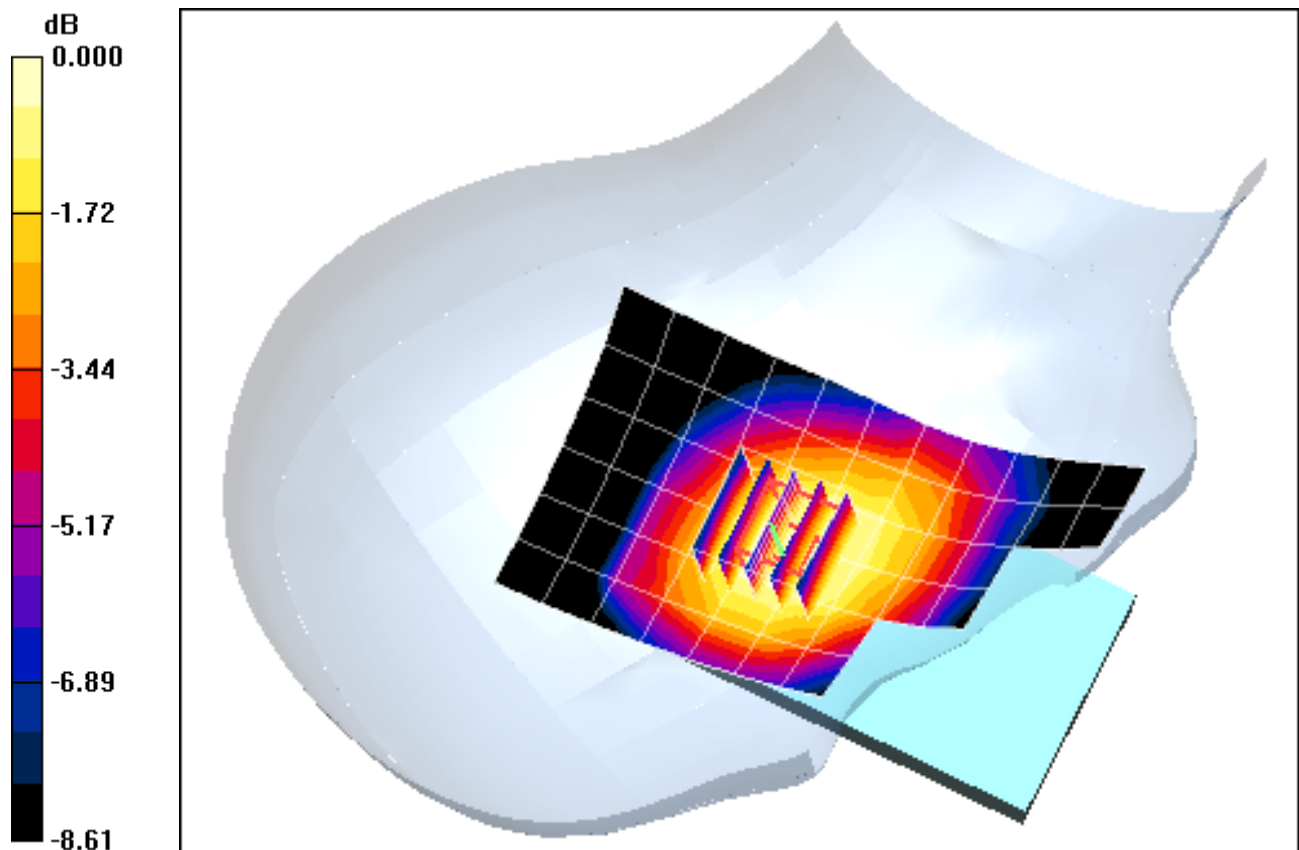

0 dB = 0.159mW/g

PCTEST ENGINEERING LABORATORY, INC.

**DUT: A3LSWDSC02C; Type: 850/1900 GSM/GPRS/EDGE Phone with Bluetooth and WLAN
Serial: FI-095-A**

Communication System: GSM850; Frequency: 836.6 MHz; Duty Cycle: 1:8.3
Medium: 835 Head; Medium parameters used (interpolated):
 $f = 836.6 \text{ MHz}$; $\sigma = 0.867 \text{ mho/m}$; $\epsilon_r = 39.99$; $\rho = 1000 \text{ kg/m}^3$
Phantom section: Left Section

Test Date: 05-04-2011; Ambient Temp: 24.0°C; Tissue Temp: 22.6°C

Probe: EX3DV4 - SN3561; ConvF(7.96, 7.96, 7.96); Calibrated: 8/19/2010
Sensor-Surface: 4mm (Mechanical Surface Detection)
Electronics: DAE4 Sn649; Calibrated: 2/21/2011
Phantom: SAM Sub; Type: SAM 4.0; Serial: TP-1357
Measurement SW: DASY4, V4.7 Build 80; Postprocessing SW: SEMCAD, V1.8 Build 186

Mode: GSM 850, Left Head, Touch, Mid.ch

Area Scan (7x14x1): Measurement grid: dx=15mm, dy=15mm
Zoom Scan (5x5x7)/Cube 0: Measurement grid: dx=8mm, dy=8mm, dz=5mm
Reference Value = 15.3 V/m
Peak SAR (extrapolated) = 0.255 W/kg
SAR(1 g) = 0.207 mW/g; SAR(10 g) = 0.157 mW/g

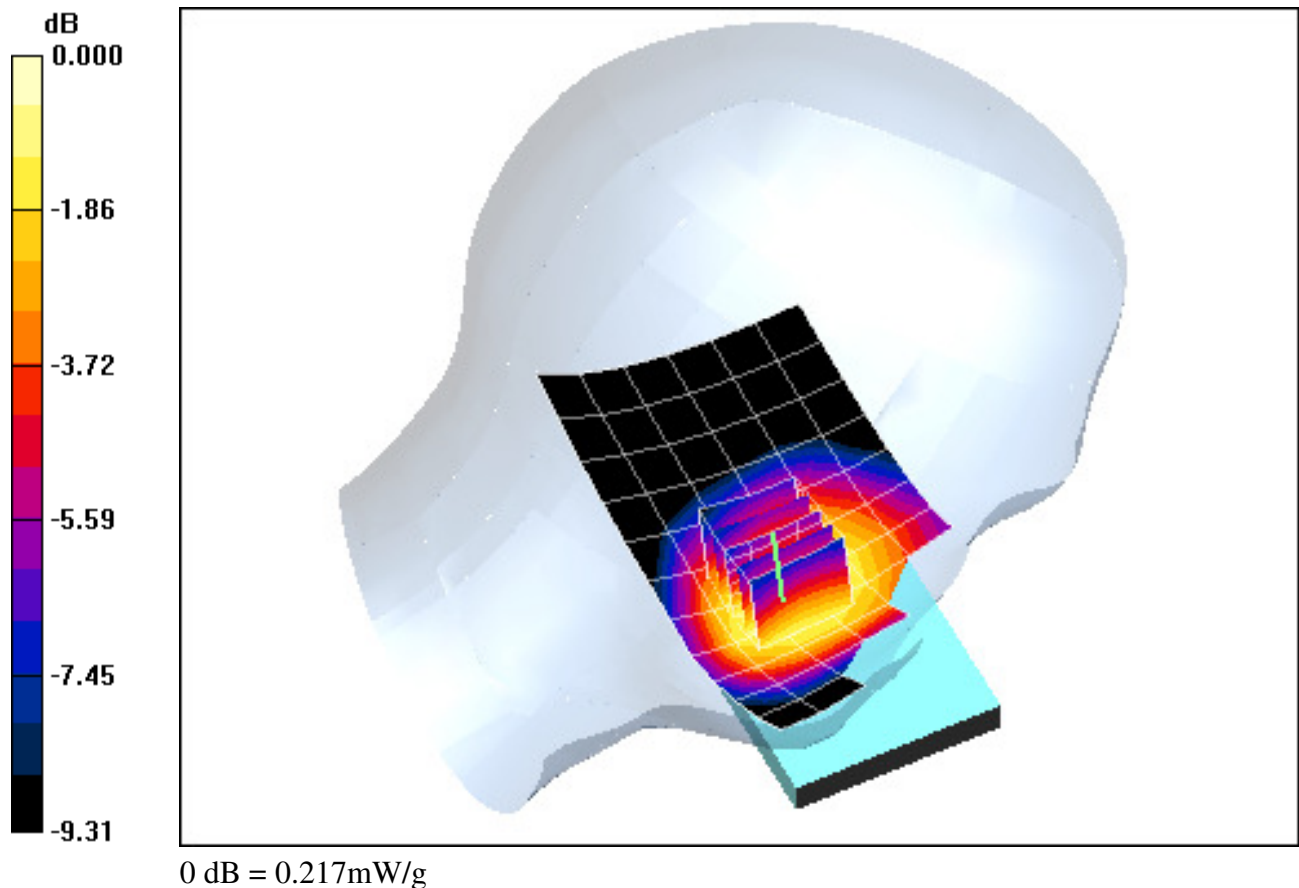

PCTEST ENGINEERING LABORATORY, INC.

**DUT: A3LSWDSC02C; Type: 850/1900 GSM/GPRS/EDGE Phone with Bluetooth and WLAN
Serial: FI-095-A**

Communication System: GSM850; Frequency: 836.6 MHz; Duty Cycle: 1:8.3
Medium: 835 Head; Medium parameters used (interpolated):
 $f = 836.6 \text{ MHz}$; $\sigma = 0.867 \text{ mho/m}$; $\epsilon_r = 39.99$; $\rho = 1000 \text{ kg/m}^3$
Phantom section: Left Section

Test Date: 05-04-2011; Ambient Temp: 24.0°C; Tissue Temp: 22.6°C

Probe: EX3DV4 - SN3561; ConvF(7.96, 7.96, 7.96); Calibrated: 8/19/2010
Sensor-Surface: 4mm (Mechanical Surface Detection)
Electronics: DAE4 Sn649; Calibrated: 2/21/2011
Phantom: SAM Sub; Type: SAM 4.0; Serial: TP-1357
Measurement SW: DASY4, V4.7 Build 80; Postprocessing SW: SEMCAD, V1.8 Build 186

Mode: GSM 850, Left Head, Tilt, Mid.ch

Area Scan (7x14x1): Measurement grid: dx=15mm, dy=15mm
Zoom Scan (5x5x7)/Cube 0: Measurement grid: dx=8mm, dy=8mm, dz=5mm
Reference Value = 7.54 V/m
Peak SAR (extrapolated) = 0.163 W/kg
SAR(1 g) = 0.133 mW/g; SAR(10 g) = 0.104 mW/g

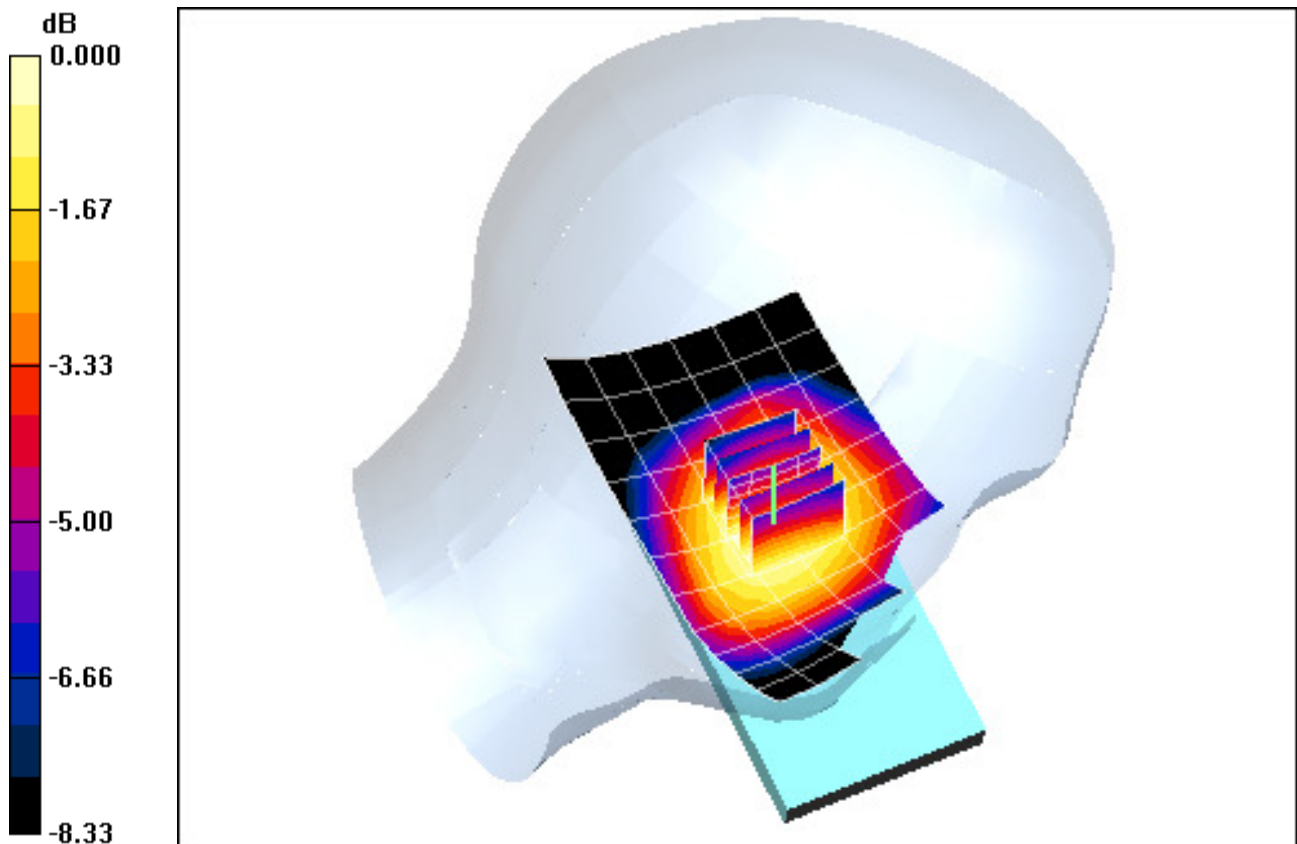

0 dB = 0.138mW/g

PCTEST ENGINEERING LABORATORY, INC.

**DUT: A3LSWDSC02C; Type: 850/1900 GSM/GPRS/EDGE Phone with Bluetooth and WLAN
Serial: FI-095-A**

Communication System: GSM1900; Frequency: 1880 MHz; Duty Cycle: 1:8.3
Medium: 1900 Head; Medium parameters used:
 $f = 1880 \text{ MHz}; \sigma = 1.44 \text{ mho/m}; \epsilon_r = 40.45; \rho = 1000 \text{ kg/m}^3$
Phantom section: Right Section

Test Date: 05-02-2011; Ambient Temp: 23.9°C; Tissue Temp: 22.8°C

Probe: EX3DV4 - SN3550; ConvF(7.01, 7.01, 7.01); Calibrated: 2/14/2011
Sensor-Surface: 4mm (Mechanical Surface Detection)
Electronics: DAE4 Sn859; Calibrated: 7/8/2010
Phantom: SAM Main; Type: SAM 4.0; Serial: TP-1114
Measurement SW: DASY4, V4.7 Build 80; Postprocessing SW: SEMCAD, V1.8 Build 186

Mode: GSM 1900, Right Head, Touch, Mid.ch

Area Scan (8x12x1): Measurement grid: dx=15mm, dy=15mm
Zoom Scan (5x5x7)/Cube 0: Measurement grid: dx=8mm, dy=8mm, dz=5mm
Reference Value = 6.68 V/m
Peak SAR (extrapolated) = 0.119 W/kg
SAR(1 g) = 0.071 mW/g; SAR(10 g) = 0.042 mW/g

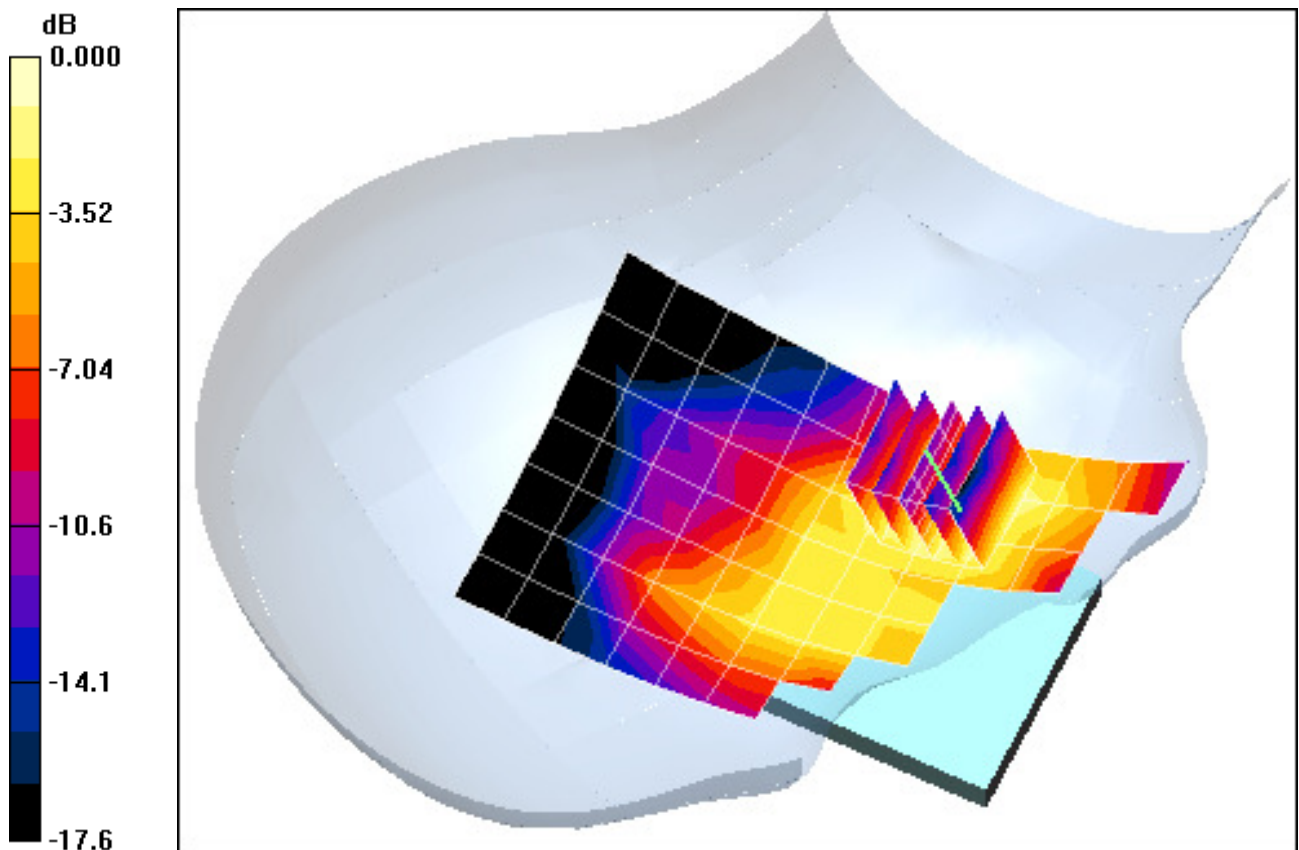

0 dB = 0.077mW/g

PCTEST ENGINEERING LABORATORY, INC.

**DUT: A3LSWDSC02C; Type: 850/1900 GSM/GPRS/EDGE Phone with Bluetooth and WLAN
Serial: FI-095-A**

Communication System: GSM1900; Frequency: 1880 MHz; Duty Cycle: 1:8.3

Medium: 1900 Head; Medium parameters used:

$f = 1880 \text{ MHz}$; $\sigma = 1.44 \text{ mho/m}$; $\epsilon_r = 40.45$; $\rho = 1000 \text{ kg/m}^3$

Phantom section: Right Section

Test Date: 05-02-2011; Ambient Temp: 23.9°C; Tissue Temp: 22.8°C

Probe: EX3DV4 - SN3550; ConvF(7.01, 7.01, 7.01); Calibrated: 2/14/2011

Sensor-Surface: 4mm (Mechanical Surface Detection)

Electronics: DAE4 Sn859; Calibrated: 7/8/2010

Phantom: SAM Main; Type: SAM 4.0; Serial: TP-1114

Measurement SW: DASY4, V4.7 Build 80; Postprocessing SW: SEMCAD, V1.8 Build 186

Mode: GSM 1900, Right Head, Tilt, Mid.ch

Area Scan (8x12x1): Measurement grid: dx=15mm, dy=15mm

Zoom Scan (5x5x7)/Cube 0: Measurement grid: dx=8mm, dy=8mm, dz=5mm

Reference Value = 3.87 V/m

Peak SAR (extrapolated) = 0.043 W/kg

SAR(1 g) = 0.020 mW/g; SAR(10 g) = 0.010 mW/g

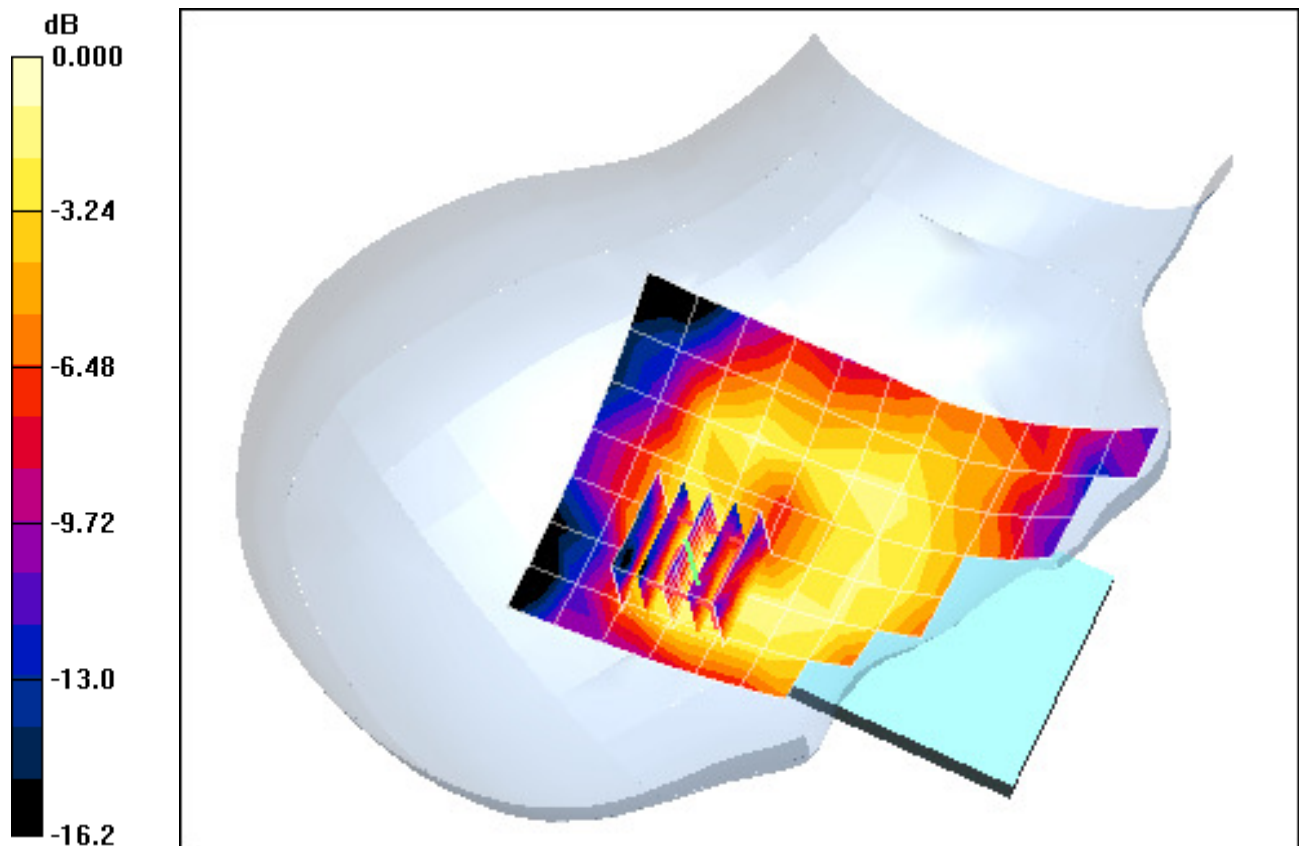

0 dB = 0.021mW/g

PCTEST ENGINEERING LABORATORY, INC.

**DUT: A3LSWDSC02C; Type: 850/1900 GSM/GPRS/EDGE Phone with Bluetooth and WLAN
Serial: FI-095-A**

Communication System: GSM1900; Frequency: 1880 MHz; Duty Cycle: 1:8.3

Medium: 1900 Head; Medium parameters used:

$f = 1880 \text{ MHz}$; $\sigma = 1.44 \text{ mho/m}$; $\epsilon_r = 40.45$; $\rho = 1000 \text{ kg/m}^3$

Phantom section: Left Section

Test Date: 05-02-2011; Ambient Temp: 23.9°C; Tissue Temp: 22.8°C

Probe: EX3DV4 - SN3550; ConvF(7.01, 7.01, 7.01); Calibrated: 2/14/2011

Sensor-Surface: 4mm (Mechanical Surface Detection)

Electronics: DAE4 Sn859; Calibrated: 7/8/2010

Phantom: SAM Main; Type: SAM 4.0; Serial: TP-1114

Measurement SW: DASY4, V4.7 Build 80; Postprocessing SW: SEMCAD, V1.8 Build 186

Mode: GSM 1900, Left Head, Touch, Mid.ch

Area Scan (8x12x1): Measurement grid: dx=15mm, dy=15mm

Zoom Scan (5x5x7)/Cube 0: Measurement grid: dx=8mm, dy=8mm, dz=5mm

Reference Value = 7.76 V/m

Peak SAR (extrapolated) = 0.132 W/kg

SAR(1 g) = 0.087 mW/g; SAR(10 g) = 0.054 mW/g

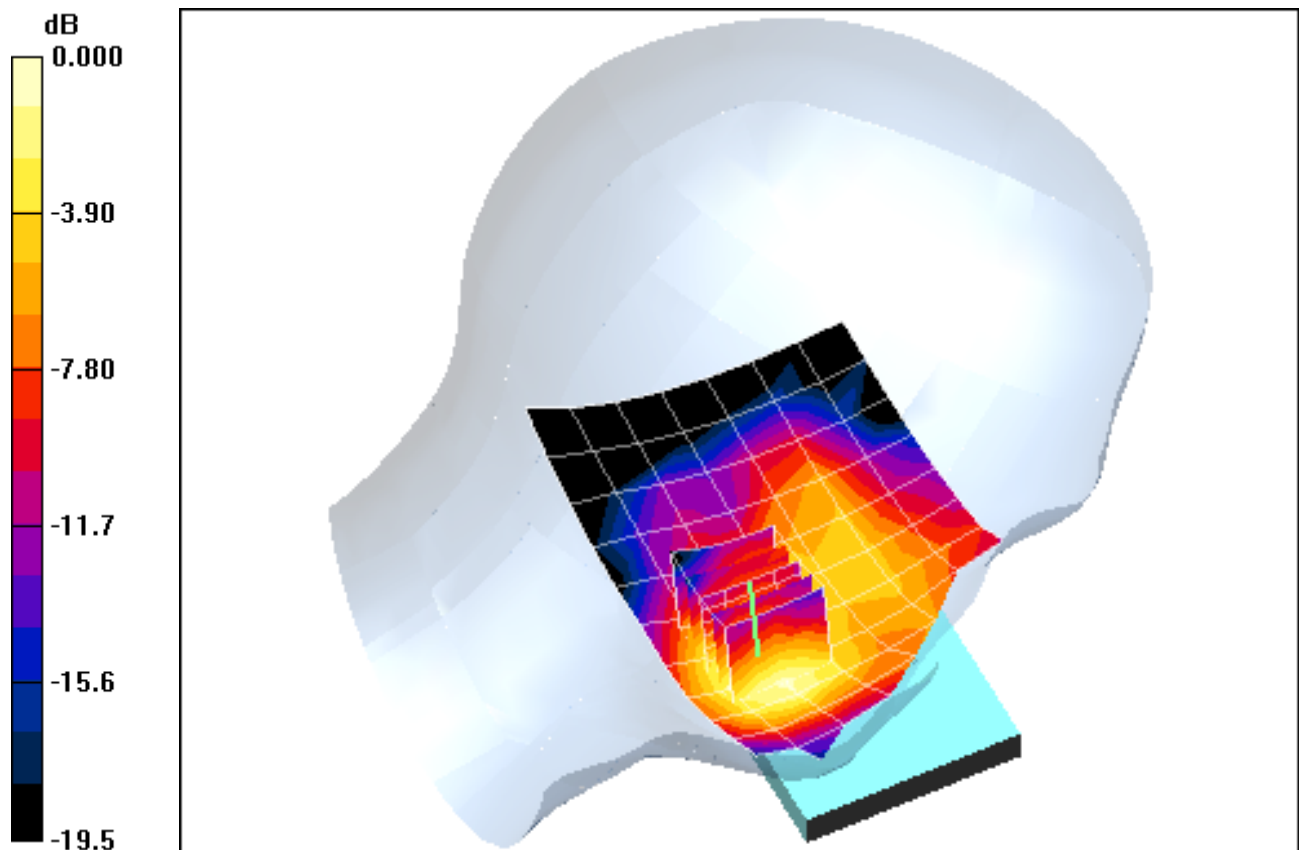

0 dB = 0.094mW/g

PCTEST ENGINEERING LABORATORY, INC.

**DUT: A3LSWDSC02C; Type: 850/1900 GSM/GPRS/EDGE Phone with Bluetooth and WLAN
Serial: FI-095-A**

Communication System: GSM1900; Frequency: 1880 MHz; Duty Cycle: 1:8.3
Medium: 1900 Head; Medium parameters used:
 $f = 1880 \text{ MHz}; \sigma = 1.44 \text{ mho/m}; \epsilon_r = 40.45; \rho = 1000 \text{ kg/m}^3$
Phantom section: Left Section

Test Date: 05-02-2011; Ambient Temp: 23.9°C; Tissue Temp: 22.8°C

Probe: EX3DV4 - SN3550; ConvF(7.01, 7.01, 7.01); Calibrated: 2/14/2011
Sensor-Surface: 4mm (Mechanical Surface Detection)
Electronics: DAE4 Sn859; Calibrated: 7/8/2010
Phantom: SAM Main; Type: SAM 4.0; Serial: TP-1114
Measurement SW: DASY4, V4.7 Build 80; Postprocessing SW: SEMCAD, V1.8 Build 186

Mode: GSM 1900, Left Head, Touch, Mid.ch

Area Scan (8x12x1): Measurement grid: dx=15mm, dy=15mm
Zoom Scan (5x5x7)/Cube 0: Measurement grid: dx=8mm, dy=8mm, dz=5mm
Reference Value = 7.76 V/m
Peak SAR (extrapolated) = 0.132 W/kg
SAR(1 g) = 0.087 mW/g; SAR(10 g) = 0.054 mW/g

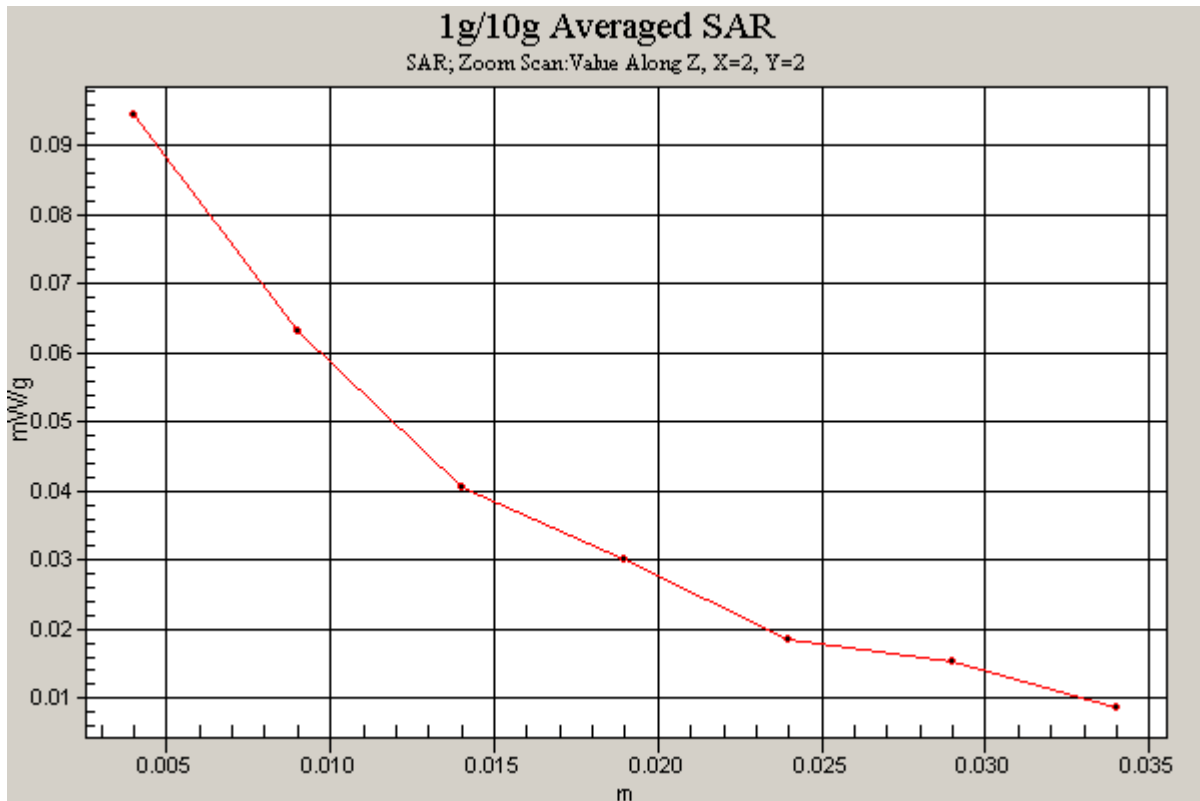

PCTEST ENGINEERING LABORATORY, INC.

**DUT: A3LSWDSC02C; Type: 850/1900 GSM/GPRS/EDGE Phone with Bluetooth and WLAN
Serial: FI-095-A**

Communication System: GSM1900; Frequency: 1880 MHz; Duty Cycle: 1:8.3

Medium: 1900 Head; Medium parameters used:

$f = 1880 \text{ MHz}$; $\sigma = 1.44 \text{ mho/m}$; $\epsilon_r = 40.45$; $\rho = 1000 \text{ kg/m}^3$

Phantom section: Left Section

Test Date: 05-02-2011; Ambient Temp: 23.9°C; Tissue Temp: 22.8°C

Probe: EX3DV4 - SN3550; ConvF(7.01, 7.01, 7.01); Calibrated: 2/14/2011

Sensor-Surface: 4mm (Mechanical Surface Detection)

Electronics: DAE4 Sn859; Calibrated: 7/8/2010

Phantom: SAM Main; Type: SAM 4.0; Serial: TP-1114

Measurement SW: DASY4, V4.7 Build 80; Postprocessing SW: SEMCAD, V1.8 Build 186

Mode: GSM 1900, Left Head, Tilt, Mid.ch

Area Scan (8x12x1): Measurement grid: dx=15mm, dy=15mm

Zoom Scan (5x5x7)/Cube 0: Measurement grid: dx=8mm, dy=8mm, dz=5mm

Reference Value = 4.15 V/m

Peak SAR (extrapolated) = 0.041 W/kg

SAR(1 g) = 0.024 mW/g; SAR(10 g) = 0.014 mW/g

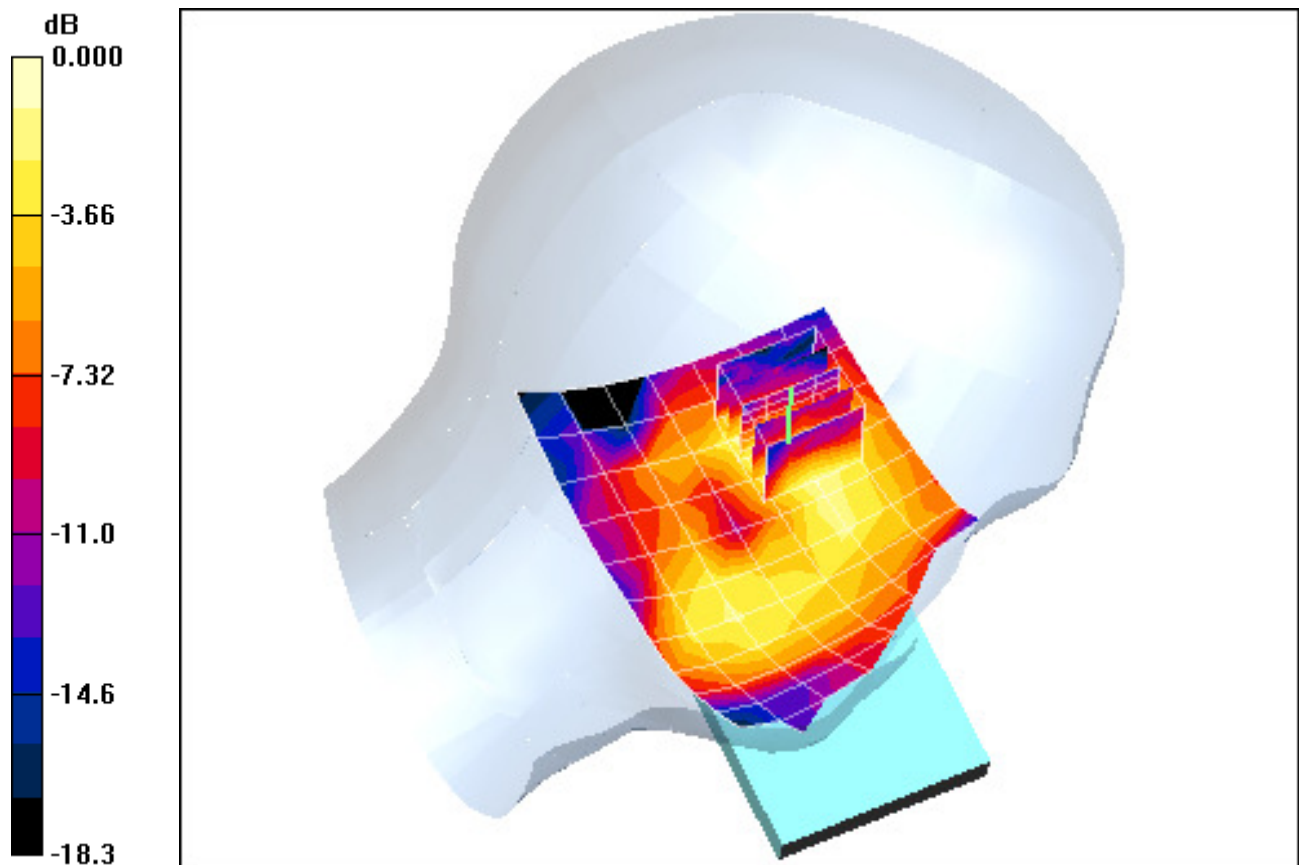

0 dB = 0.027mW/g

PCTEST ENGINEERING LABORATORY, INC.

**DUT: A3LSWDSC02C; Type: 850/1900 GSM/GPRS/EDGE Phone with Bluetooth and WLAN
Serial: FI-095-A**

Communication System: IEEE 802.11b; Frequency: 2462 MHz; Duty Cycle: 1:1
Medium: 2450 Head; Medium parameters used (interpolated):
 $f = 2462 \text{ MHz}$; $\sigma = 1.9 \text{ mho/m}$; $\epsilon_r = 37.4$; $\rho = 1000 \text{ kg/m}^3$
Phantom section: Right Section

Test Date: 05-03-2011; Ambient Temp: 23.3°C; Tissue Temp: 22°C

Probe: EX3DV4 - SN3550; ConvF(6.29, 6.29, 6.29); Calibrated: 2/14/2011
Sensor-Surface: 3mm (Mechanical Surface Detection)
Electronics: DAE4 Sn859; Calibrated: 7/8/2010
Phantom: SAM Main; Type: SAM 4.0; Serial: TP-1114
Measurement SW: DASY4, V4.7 Build 80; Postprocessing SW: SEMCAD, V1.8 Build 186

Mode: IEEE 802.11b, Right Head, Touch, Ch 11, 1 Mbps

Area Scan (7x11x1): Measurement grid: dx=15mm, dy=15mm
Zoom Scan (5x5x7)/Cube 0: Measurement grid: dx=8mm, dy=8mm, dz=5mm
Reference Value = 6.48 V/m
Peak SAR (extrapolated) = 0.140 W/kg
SAR(1 g) = 0.073 mW/g; SAR(10 g) = 0.040 mW/g

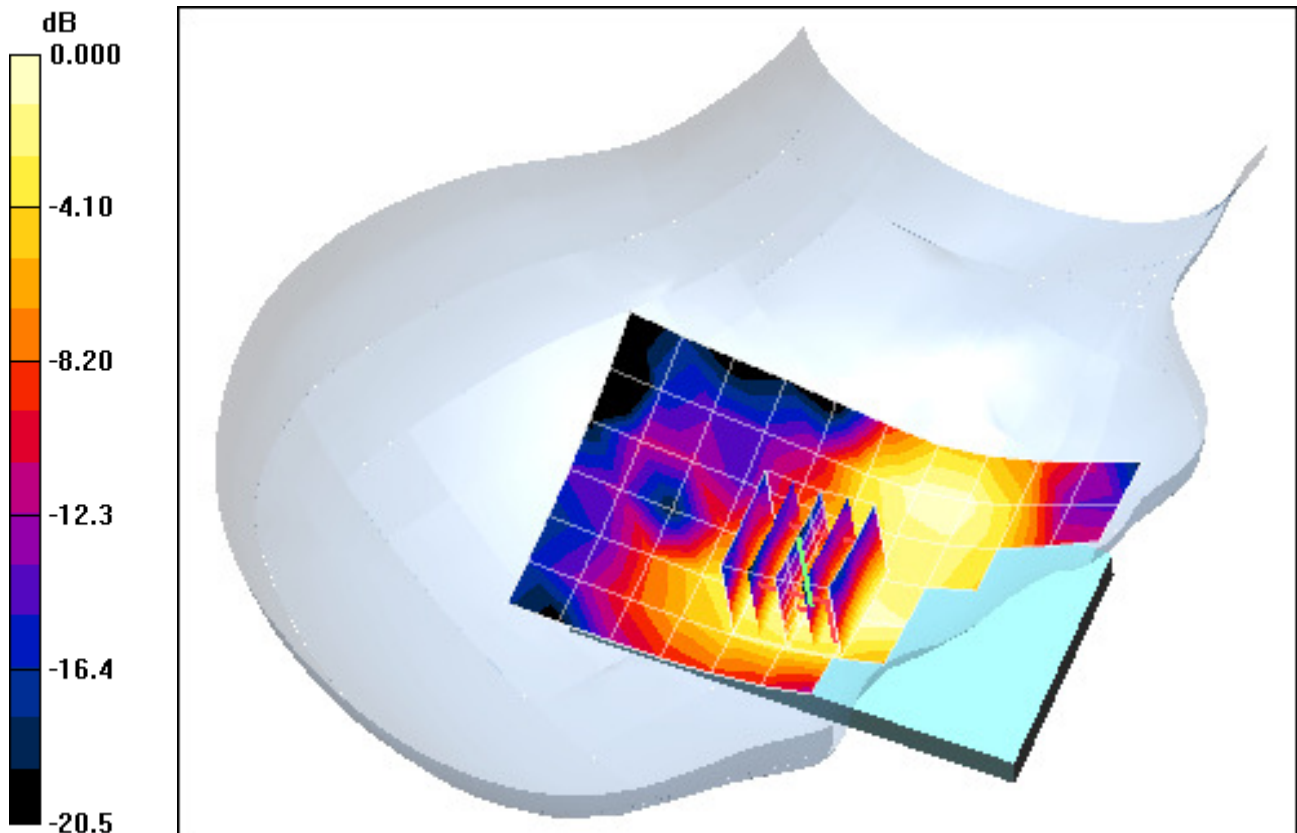

0 dB = 0.088mW/g

PCTEST ENGINEERING LABORATORY, INC.

**DUT: A3LSWDSC02C; Type: 850/1900 GSM/GPRS/EDGE Phone with Bluetooth and WLAN
Serial: FI-095-A**

Communication System: IEEE 802.11b; Frequency: 2462 MHz; Duty Cycle: 1:1
Medium: 2450 Head; Medium parameters used (interpolated):
 $f = 2462 \text{ MHz}$; $\sigma = 1.9 \text{ mho/m}$; $\epsilon_r = 37.4$; $\rho = 1000 \text{ kg/m}^3$
Phantom section: Right Section

Test Date: 05-03-2011; Ambient Temp: 23.3°C; Tissue Temp: 22°C

Probe: EX3DV4 - SN3550; ConvF(6.29, 6.29, 6.29); Calibrated: 2/14/2011
Sensor-Surface: 3mm (Mechanical Surface Detection)
Electronics: DAE4 Sn859; Calibrated: 7/8/2010
Phantom: SAM Main; Type: SAM 4.0; Serial: TP-1114
Measurement SW: DASY4, V4.7 Build 80; Postprocessing SW: SEMCAD, V1.8 Build 186

Mode: IEEE 802.11b, Right Head, Tilt, Ch 11, 1 Mbps

Area Scan (7x11x1): Measurement grid: dx=15mm, dy=15mm
Zoom Scan (5x5x7)/Cube 0: Measurement grid: dx=8mm, dy=8mm, dz=5mm
Reference Value = 4.51 V/m
Peak SAR (extrapolated) = 0.158 W/kg
SAR(1 g) = 0.038 mW/g; SAR(10 g) = 0.018 mW/g

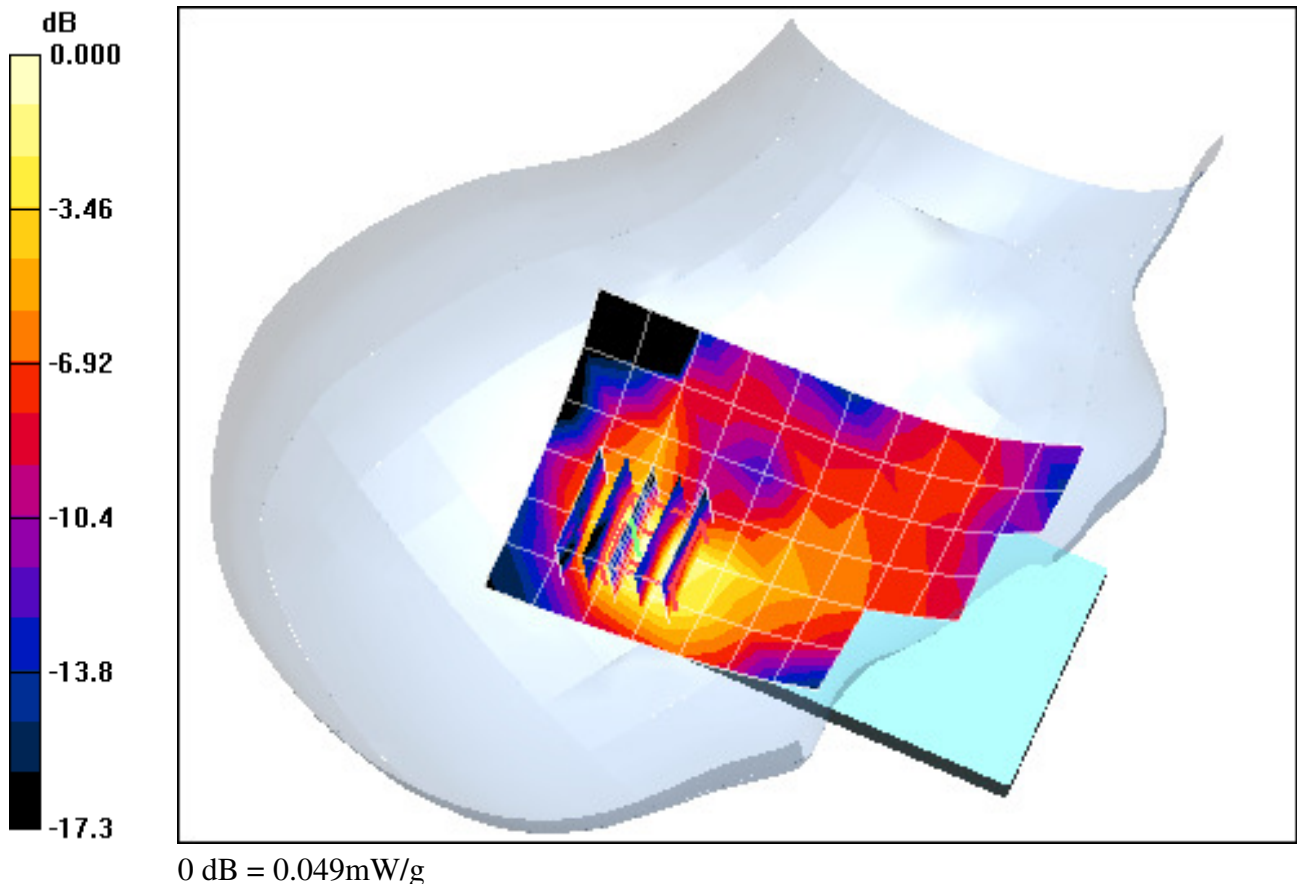

PCTEST ENGINEERING LABORATORY, INC.

**DUT: A3LSWDSC02C; Type: 850/1900 GSM/GPRS/EDGE Phone with Bluetooth and WLAN
Serial: FI-095-A**

Communication System: IEEE 802.11b; Frequency: 2462 MHz; Duty Cycle: 1:1
Medium: 2450 Head; Medium parameters used (interpolated):
 $f = 2462 \text{ MHz}$; $\sigma = 1.9 \text{ mho/m}$; $\epsilon_r = 37.4$; $\rho = 1000 \text{ kg/m}^3$
Phantom section: Left Section

Test Date: 05-03-2011; Ambient Temp: 23.3°C; Tissue Temp: 22°C

Probe: EX3DV4 - SN3550; ConvF(6.29, 6.29, 6.29); Calibrated: 2/14/2011
Sensor-Surface: 3mm (Mechanical Surface Detection)
Electronics: DAE4 Sn859; Calibrated: 7/8/2010
Phantom: SAM Main; Type: SAM 4.0; Serial: TP-1114
Measurement SW: DASY4, V4.7 Build 80; Postprocessing SW: SEMCAD, V1.8 Build 186

Mode: IEEE 802.11b, Left Head, Touch, Ch 11, 1 Mbps

Area Scan (7x11x1): Measurement grid: dx=15mm, dy=15mm
Zoom Scan (5x5x7)/Cube 0: Measurement grid: dx=8mm, dy=8mm, dz=5mm
Reference Value = 7.61 V/m
Peak SAR (extrapolated) = 0.205 W/kg
SAR(1 g) = 0.104 mW/g; SAR(10 g) = 0.054 mW/g

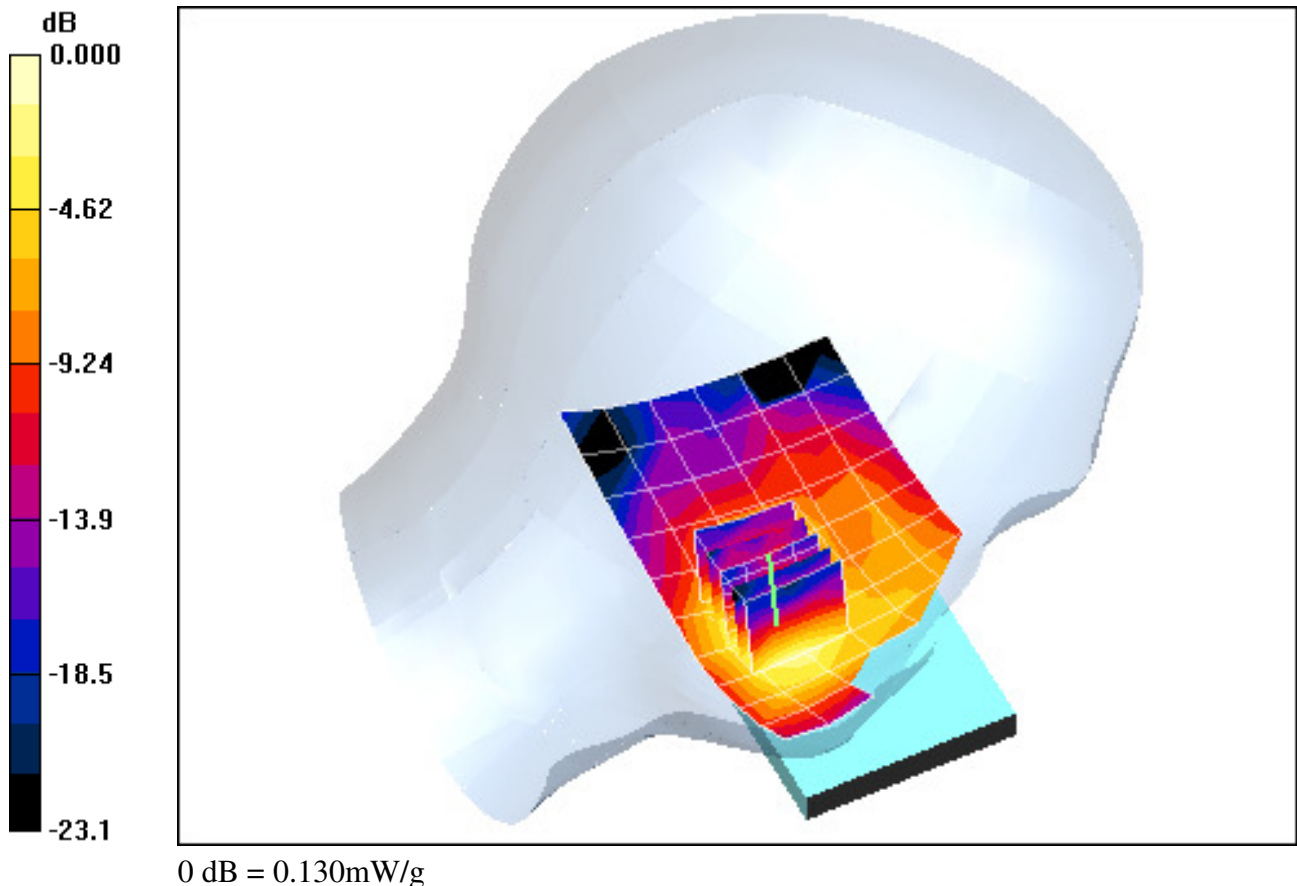

PCTEST ENGINEERING LABORATORY, INC.

**DUT: A3LSWDSC02C; Type: 850/1900 GSM/GPRS/EDGE Phone with Bluetooth and WLAN
Serial: FI-095-A**

Communication System: IEEE 802.11b; Frequency: 2462 MHz; Duty Cycle: 1:1
Medium: 2450 Head; Medium parameters used (interpolated):
 $f = 2462 \text{ MHz}$; $\sigma = 1.9 \text{ mho/m}$; $\epsilon_r = 37.4$; $\rho = 1000 \text{ kg/m}^3$
Phantom section: Left Section

Test Date: 05-03-2011; Ambient Temp: 23.3°C; Tissue Temp: 22°C

Probe: EX3DV4 - SN3550; ConvF(6.29, 6.29, 6.29); Calibrated: 2/14/2011
Sensor-Surface: 3mm (Mechanical Surface Detection)
Electronics: DAE4 Sn859; Calibrated: 7/8/2010
Phantom: SAM Main; Type: SAM 4.0; Serial: TP-1114
Measurement SW: DASY4, V4.7 Build 80; Postprocessing SW: SEMCAD, V1.8 Build 186

Mode: IEEE 802.11b, Left Head, Touch, Ch 11, 1 Mbps

Area Scan (7x11x1): Measurement grid: dx=15mm, dy=15mm
Zoom Scan (5x5x7)/Cube 0: Measurement grid: dx=8mm, dy=8mm, dz=5mm
Reference Value = 7.61 V/m
Peak SAR (extrapolated) = 0.205 W/kg
SAR(1 g) = 0.104 mW/g; SAR(10 g) = 0.054 mW/g

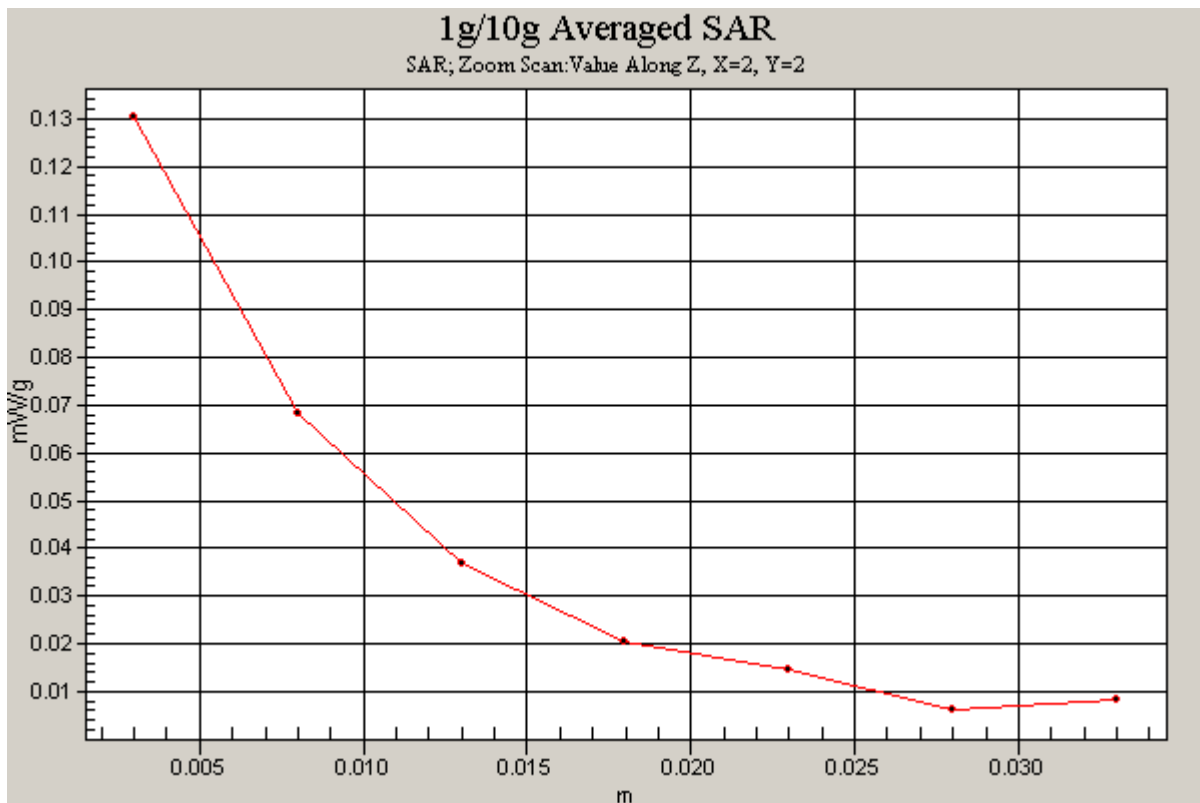

PCTEST ENGINEERING LABORATORY, INC.

**DUT: A3LSWDSC02C; Type: 850/1900 GSM/GPRS/EDGE Phone with Bluetooth and WLAN
Serial: FI-095-A**

Communication System: IEEE 802.11b; Frequency: 2462 MHz; Duty Cycle: 1:1
Medium: 2450 Head; Medium parameters used (interpolated):
 $f = 2462 \text{ MHz}$; $\sigma = 1.9 \text{ mho/m}$; $\epsilon_r = 37.4$; $\rho = 1000 \text{ kg/m}^3$
Phantom section: Left Section

Test Date: 05-03-2011; Ambient Temp: 23.3°C; Tissue Temp: 22°C

Probe: EX3DV4 - SN3550; ConvF(6.29, 6.29, 6.29); Calibrated: 2/14/2011
Sensor-Surface: 3mm (Mechanical Surface Detection)
Electronics: DAE4 Sn859; Calibrated: 7/8/2010
Phantom: SAM Main; Type: SAM 4.0; Serial: TP-1114
Measurement SW: DASY4, V4.7 Build 80; Postprocessing SW: SEMCAD, V1.8 Build 186

Mode: IEEE 802.11b, Left Head, Tilt, Ch 11, 1 Mbps

Area Scan (7x11x1): Measurement grid: dx=15mm, dy=15mm
Zoom Scan (5x5x7)/Cube 0: Measurement grid: dx=8mm, dy=8mm, dz=5mm
Reference Value = 3.04 V/m
Peak SAR (extrapolated) = 0.030 W/kg
SAR(1 g) = 0.018 mW/g; SAR(10 g) = 0.00824 mW/g

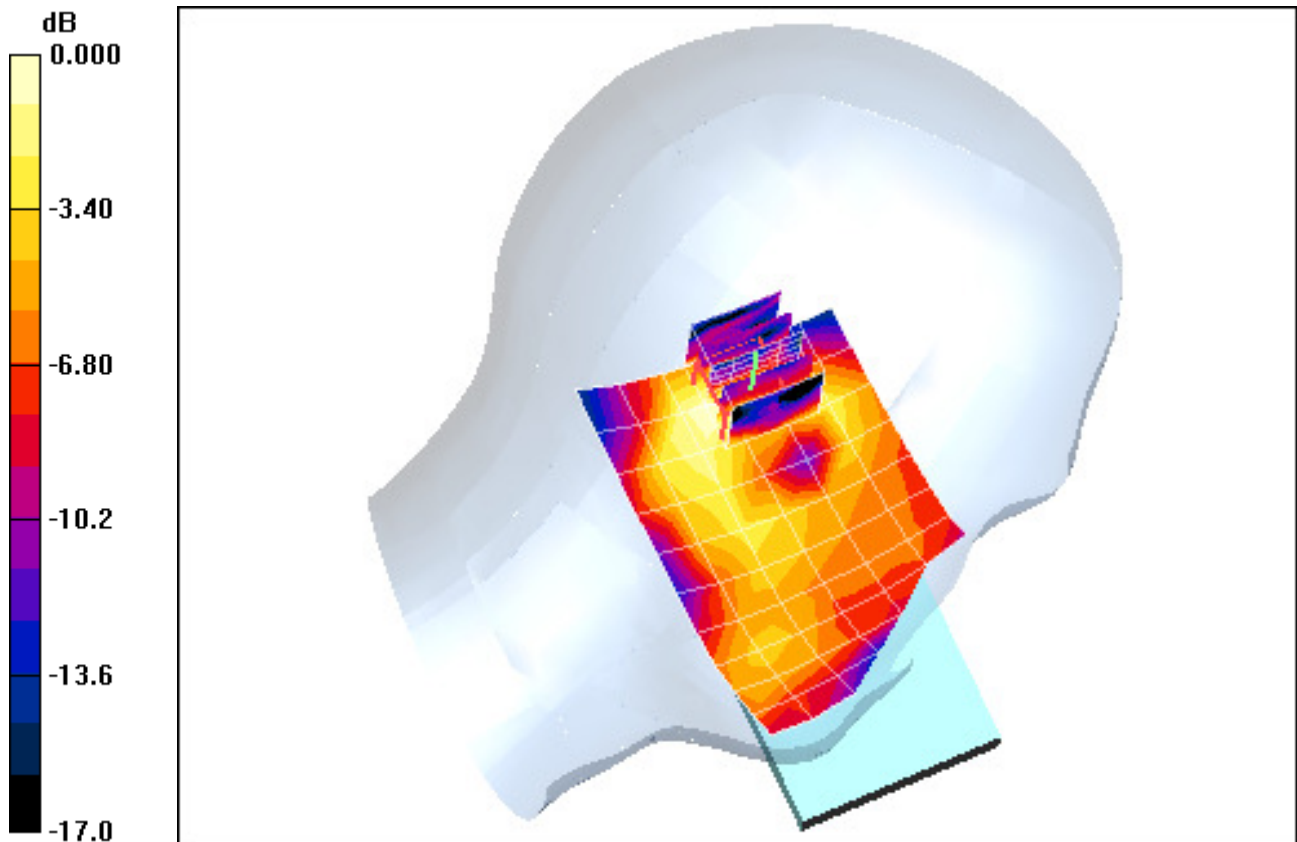

0 dB = 0.022mW/g

PCTEST ENGINEERING LABORATORY, INC.

**DUT: A3LSWDSC02C; Type: 850/1900 GSM/GPRS/EDGE Phone with Bluetooth and WLAN
Serial: FI-095-B**

Communication System: IEEE 802.11a 5.2-5.8 GHz Band; Frequency: 5180 MHz; Duty Cycle: 1:1
Medium: 5 GHz Head; Medium parameters used (interpolated):
 $f = 5180 \text{ MHz}; \sigma = 4.73 \text{ mho/m}; \epsilon_r = 37.4; \rho = 1000 \text{ kg/m}^3$
Phantom section: Right Section

Test Date: 05-04-2011; Ambient Temp: 24.3°C ; Tissue Temp: 22.8°C

Probe: EX3DV4 - SN3550; ConvF(4.06, 4.06, 4.06); Calibrated: 2/14/2011
Sensor-Surface: 2mm (Mechanical Surface Detection)
Electronics: DAE4 Sn859; Calibrated: 7/8/2010
Phantom: SAM Main; Type: SAM 4.0; Serial: TP-1114

Measurement SW: DASY4, V4.7 Build 80; Postprocessing SW: SEMCAD, V1.8 Build 186

Mode: IEEE 802.11a 5.2 GHz, Right Head, Touch, Ch 36, 6 Mbps

Area Scan (10x16x1): Measurement grid: dx=10mm, dy=10mm

Zoom Scan (7x7x11)/Cube 0: Measurement grid: dx=4mm, dy=4mm, dz=2mm

Reference Value = 1.87 V/m

Peak SAR (extrapolated) = 0.270 W/kg

SAR(1 g) = 0.021 mW/g; SAR(10 g) = 0.00485 mW/g

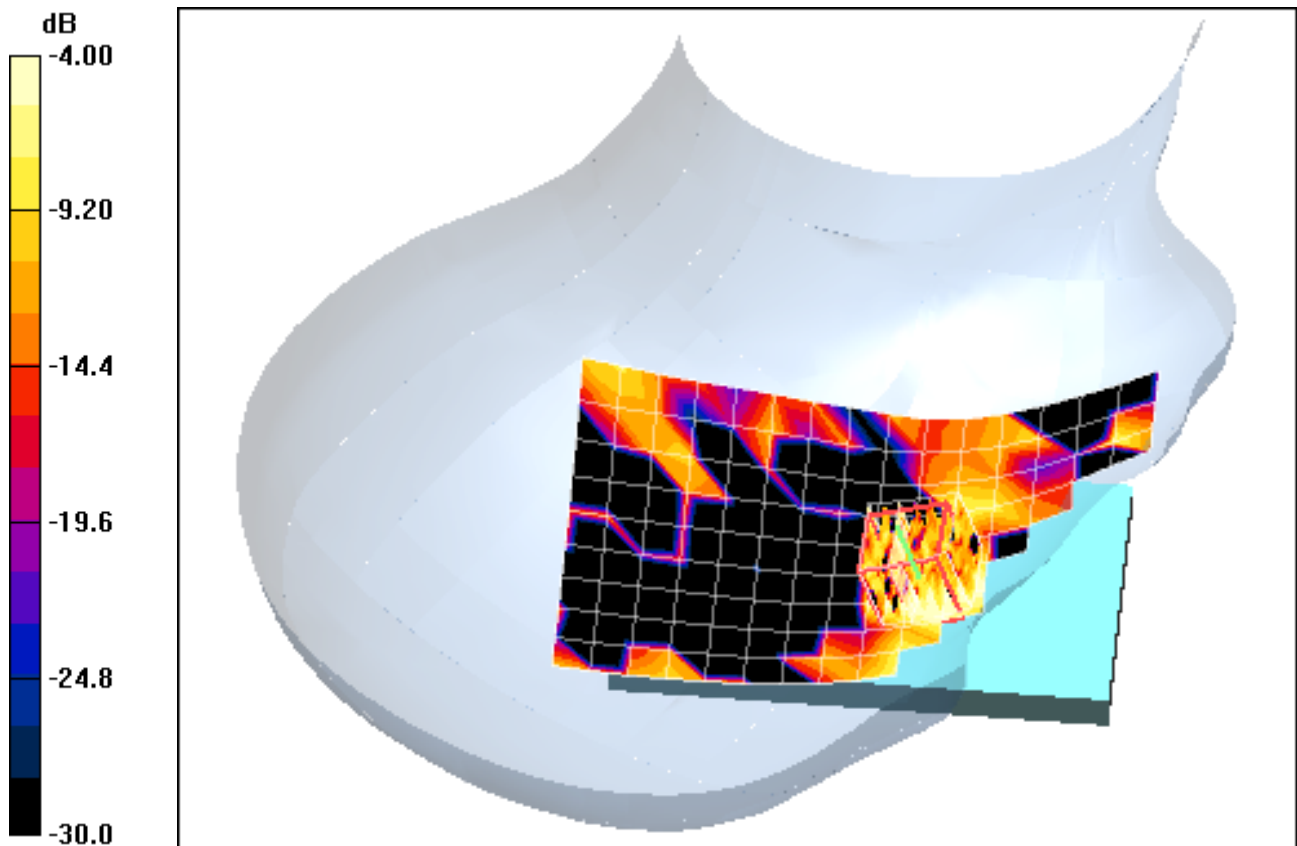

0 dB = 0.037mW/g

PCTEST ENGINEERING LABORATORY, INC.

**DUT: A3LSWDSC02C; Type: 850/1900 GSM/GPRS/EDGE Phone with Bluetooth and WLAN
Serial: FI-095-B**

Communication System: IEEE 802.11a 5.2-5.8 GHz Band; Frequency: 5180 MHz; Duty Cycle: 1:1
Medium: 5 GHz Head; Medium parameters used (interpolated):
 $f = 5180 \text{ MHz}$; $\sigma = 4.73 \text{ mho/m}$; $\epsilon_r = 37.4$; $\rho = 1000 \text{ kg/m}^3$
Phantom section: Right Section

Test Date: 05-04-2011; Ambient Temp: 24.3°C ; Tissue Temp: 22.8°C

Probe: EX3DV4 - SN3550; ConvF(4.06, 4.06, 4.06); Calibrated: 2/14/2011

Sensor-Surface: 2mm (Mechanical Surface Detection)

Electronics: DAE4 Sn859; Calibrated: 7/8/2010

Phantom: SAM Main; Type: SAM 4.0; Serial: TP-1114

Measurement SW: DASY4, V4.7 Build 80; Postprocessing SW: SEMCAD, V1.8 Build 186

Mode: IEEE 802.11a 5.2 GHz, Right Head, Tilt, Ch 36, 6 Mbps

Area Scan (10x16x1): Measurement grid: dx=10mm, dy=10mm

Zoom Scan (7x7x11)/Cube 0: Measurement grid: dx=4mm, dy=4mm, dz=2mm

Reference Value = 0.983 V/m

Peak SAR (extrapolated) = 0.034 W/kg

SAR(1 g) = 0.00203 mW/g; SAR(10 g) = 0.000408 mW/g

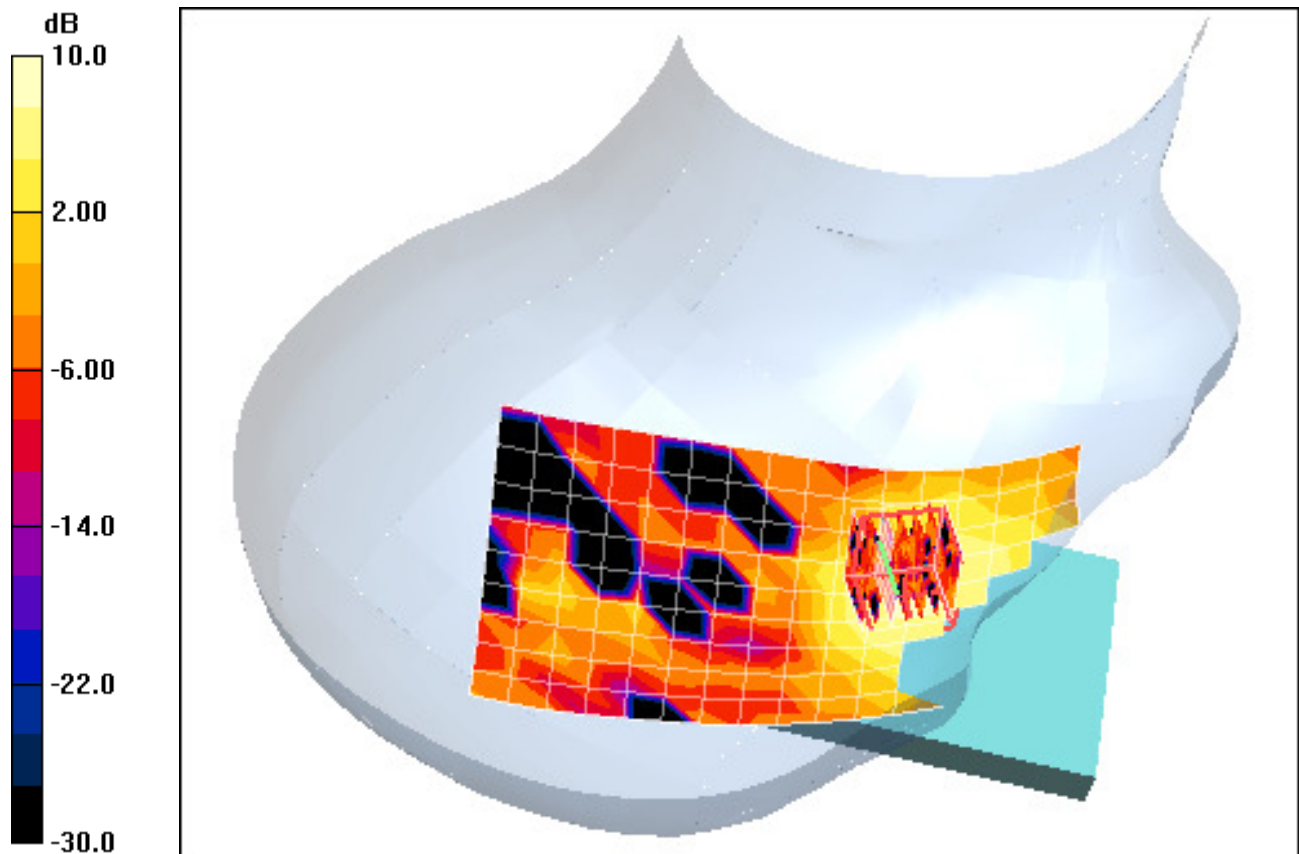

0 dB = 0.013mW/g

PCTEST ENGINEERING LABORATORY, INC.

**DUT: A3LSWDSC02C; Type: 850/1900 GSM/GPRS/EDGE Phone with Bluetooth and WLAN
Serial: FI-095-B**

Communication System: IEEE 802.11a 5.2-5.8 GHz Band; Frequency: 5180 MHz; Duty Cycle: 1:1
Medium: 5 GHz Head; Medium parameters used (interpolated):
 $f = 5180 \text{ MHz}$; $\sigma = 4.73 \text{ mho/m}$; $\epsilon_r = 37.4$; $\rho = 1000 \text{ kg/m}^3$
Phantom section: Left Section

Test Date: 05-04-2011; Ambient Temp: 24.3°C ; Tissue Temp: 22.8°C

Probe: EX3DV4 - SN3550; ConvF(4.06, 4.06, 4.06); Calibrated: 2/14/2011
Sensor-Surface: 2mm (Mechanical Surface Detection)
Electronics: DAE4 Sn859; Calibrated: 7/8/2010
Phantom: SAM Main; Type: SAM 4.0; Serial: TP-1114

Measurement SW: DASY4, V4.7 Build 80; Postprocessing SW: SEMCAD, V1.8 Build 186

Mode: IEEE 802.11a, 5.2 GHz Left Head, Tilt, Ch 36, 6 Mbps

Area Scan (10x16x1): Measurement grid: dx=10mm, dy=10mm

Zoom Scan (7x7x11)/Cube 0: Measurement grid: dx=4mm, dy=4mm, dz=2mm

Reference Value = 1.43 V/m

Peak SAR (extrapolated) = 0.084 W/kg

SAR(1 g) = 0.0082 mW/g; SAR(10 g) = 0.0024 mW/g

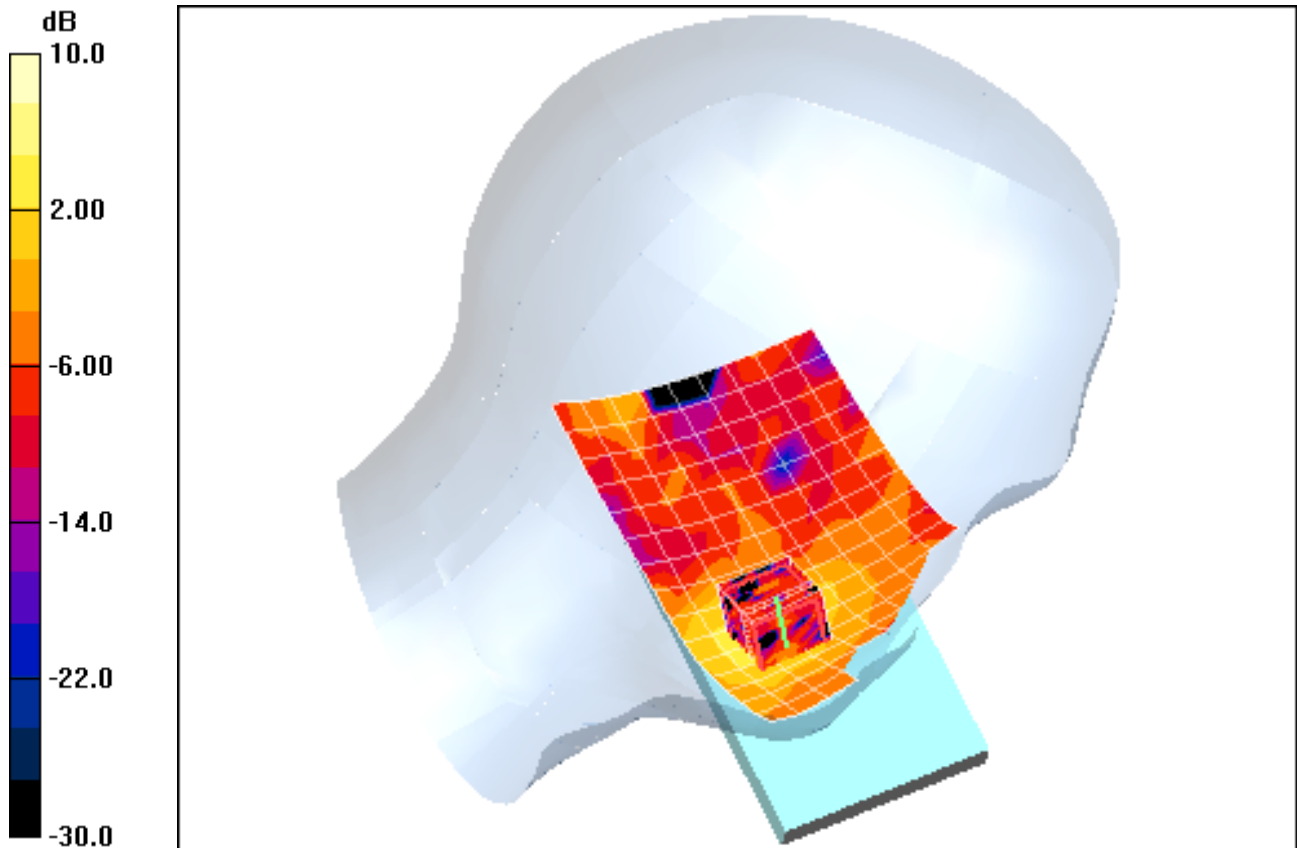

0 dB = 0.022mW/g

PCTEST ENGINEERING LABORATORY, INC.

**DUT: A3LSWDSC02C; Type: 850/1900 GSM/GPRS/EDGE Phone with Bluetooth and WLAN
Serial: FI-095-B**

Communication System: IEEE 802.11a 5.2-5.8 GHz Band; Frequency: 5180 MHz; Duty Cycle: 1:1
Medium: 5 GHz Head; Medium parameters used (interpolated):
 $f = 5180 \text{ MHz}$; $\sigma = 4.73 \text{ mho/m}$; $\epsilon_r = 37.4$; $\rho = 1000 \text{ kg/m}^3$
Phantom section: Left Section

Test Date: 05-04-2011; Ambient Temp: 24.3°C ; Tissue Temp: 22.8°C

Probe: EX3DV4 - SN3550; ConvF(4.06, 4.06, 4.06); Calibrated: 2/14/2011
Sensor-Surface: 2mm (Mechanical Surface Detection)
Electronics: DAE4 Sn859; Calibrated: 7/8/2010
Phantom: SAM Main; Type: SAM 4.0; Serial: TP-1114

Measurement SW: DASY4, V4.7 Build 80; Postprocessing SW: SEMCAD, V1.8 Build 186

Mode: IEEE 802.11a, 5.2 GHz Left Head, Tilt, Ch 36, 6 Mbps

Area Scan (10x16x1): Measurement grid: dx=10mm, dy=10mm

Zoom Scan (7x7x11)/Cube 0: Measurement grid: dx=4mm, dy=4mm, dz=2mm

Reference Value = 0.706 V/m

Peak SAR (extrapolated) = 0.022 W/kg

SAR(1 g) = 7.89e-005 mW/g; SAR(10 g) = 1.25e-005 mW/g

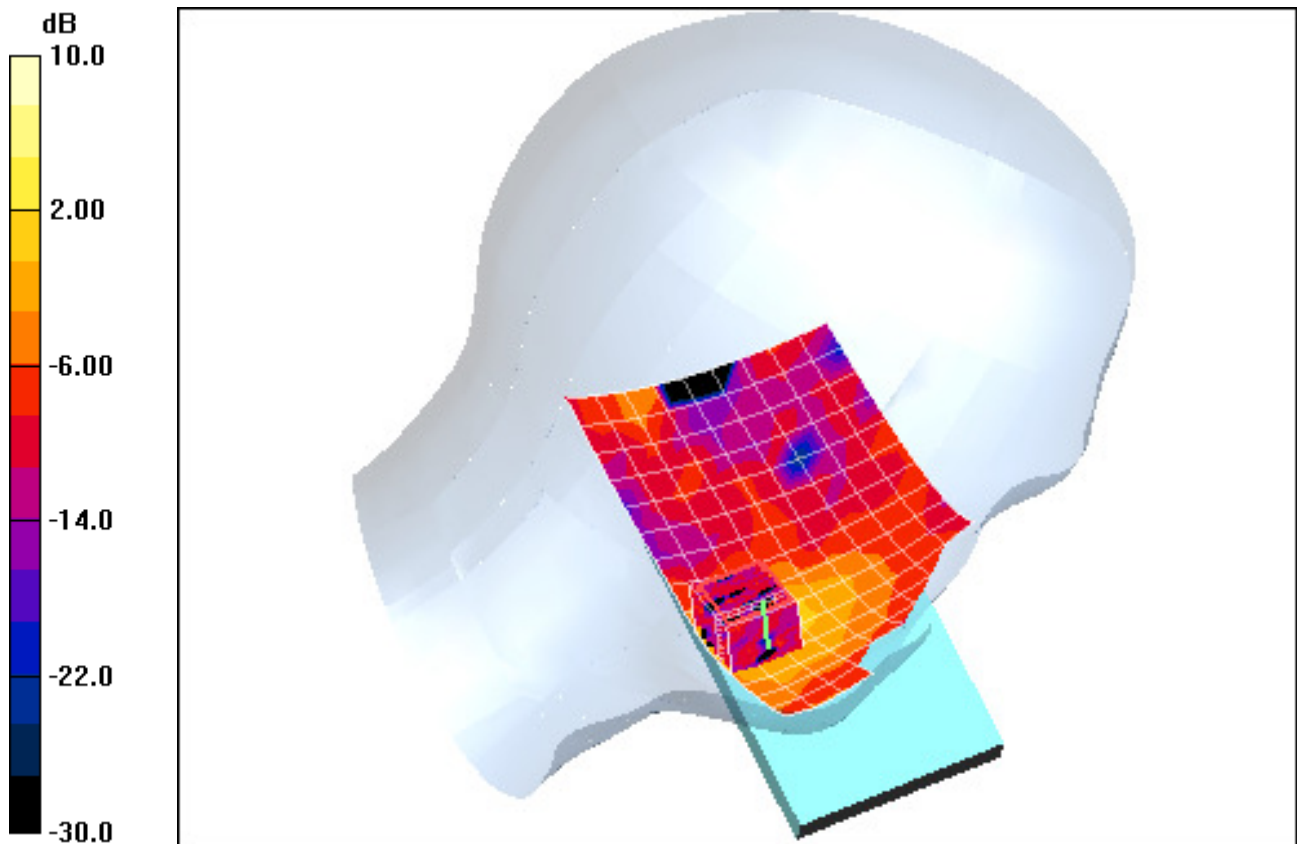

0 dB = 0.039mW/g

PCTEST ENGINEERING LABORATORY, INC.

**DUT: A3LSWDSC02C; Type: 850/1900 GSM/GPRS/EDGE Phone with Bluetooth and WLAN
Serial: FI-095-B**

Communication System: IEEE 802.11a 5.2-5.8 GHz Band; Frequency: 5260 MHz; Duty Cycle: 1:1
Medium: 5 GHz Head; Medium parameters used (interpolated):

$$f = 5260 \text{ MHz}; \sigma = 4.81 \text{ mho/m}; \epsilon_r = 37.1; \rho = 1000 \text{ kg/m}^3$$

Phantom section: Right Section

Test Date: 05-04-2011; Ambient Temp: 24.3°C ; Tissue Temp: 22.8°C

Probe: EX3DV4 - SN3550; ConvF(3.92, 3.92, 3.92); Calibrated: 2/14/2011

Sensor-Surface: 2mm (Mechanical Surface Detection)

Electronics: DAE4 Sn859; Calibrated: 7/8/2010

Phantom: SAM Main; Type: SAM 4.0; Serial: TP-1114

Measurement SW: DASY4, V4.7 Build 80; Postprocessing SW: SEMCAD, V1.8 Build 186

Mode: IEEE 802.11a 5.3 GHz, Right Head, Touch, Ch 52, 6 Mbps

Area Scan (10x16x1): Measurement grid: dx=10mm, dy=10mm

Zoom Scan (7x7x11)/Cube 0: Measurement grid: dx=4mm, dy=4mm, dz=2mm

Reference Value = 2.23 V/m

Peak SAR (extrapolated) = 0.152 W/kg

SAR(1 g) = 0.025 mW/g; SAR(10 g) = 0.00783 mW/g

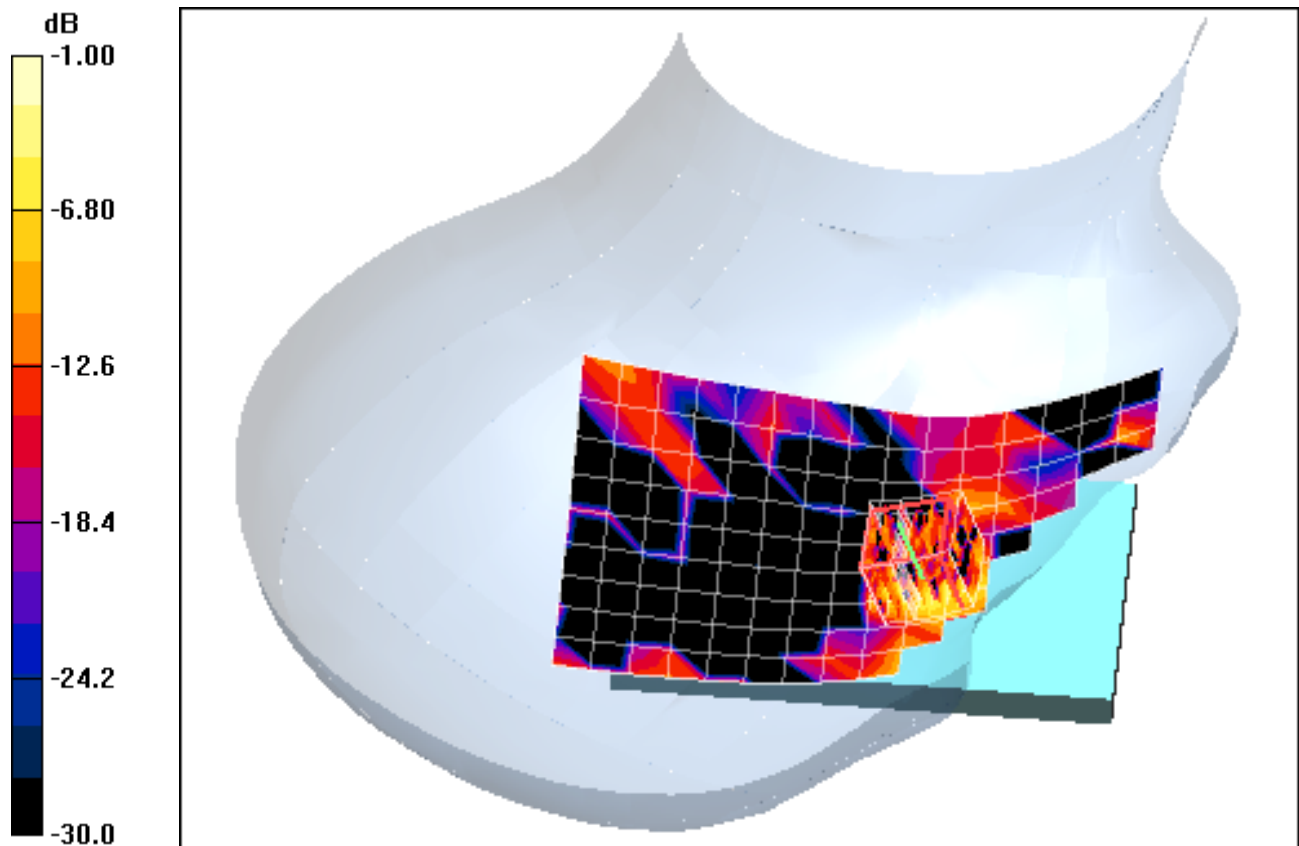

0 dB = 0.066mW/g

PCTEST ENGINEERING LABORATORY, INC.

DUT: A3LSWDSC02C; Type: 850/1900 GSM/GPRS/EDGE Phone with Bluetooth and WLAN
Serial: FI-095-B

Communication System: IEEE 802.11a 5.2-5.8 GHz Band; Frequency: 5260 MHz; Duty Cycle: 1:1
Medium: 5 GHz Head; Medium parameters used (interpolated):
 $f = 5260 \text{ MHz}$; $\sigma = 4.81 \text{ mho/m}$; $\epsilon_r = 37.1$; $\rho = 1000 \text{ kg/m}^3$
Phantom section: Right Section

Test Date: 05-04-2011; Ambient Temp: 24.3°C ; Tissue Temp: 22.8°C

Probe: EX3DV4 - SN3550; ConvF(3.92, 3.92, 3.92); Calibrated: 2/14/2011
Sensor-Surface: 2mm (Mechanical Surface Detection)
Electronics: DAE4 Sn859; Calibrated: 7/8/2010
Phantom: SAM Main; Type: SAM 4.0; Serial: TP-1114

Measurement SW: DASY4, V4.7 Build 80; Postprocessing SW: SEMCAD, V1.8 Build 186

Mode: IEEE 802.11a 5.3 GHz, Right Head, Tilt, Ch 52, 6 Mbps

Area Scan (10x16x1): Measurement grid: dx=10mm, dy=10mm

Zoom Scan (7x7x11)/Cube 0: Measurement grid: dx=4mm, dy=4mm, dz=2mm

Reference Value = 1.06 V/m

Peak SAR (extrapolated) = 0.047 W/kg

SAR(1 g) = 0.0042 mW/g; SAR(10 g) = 0.0014 mW/g

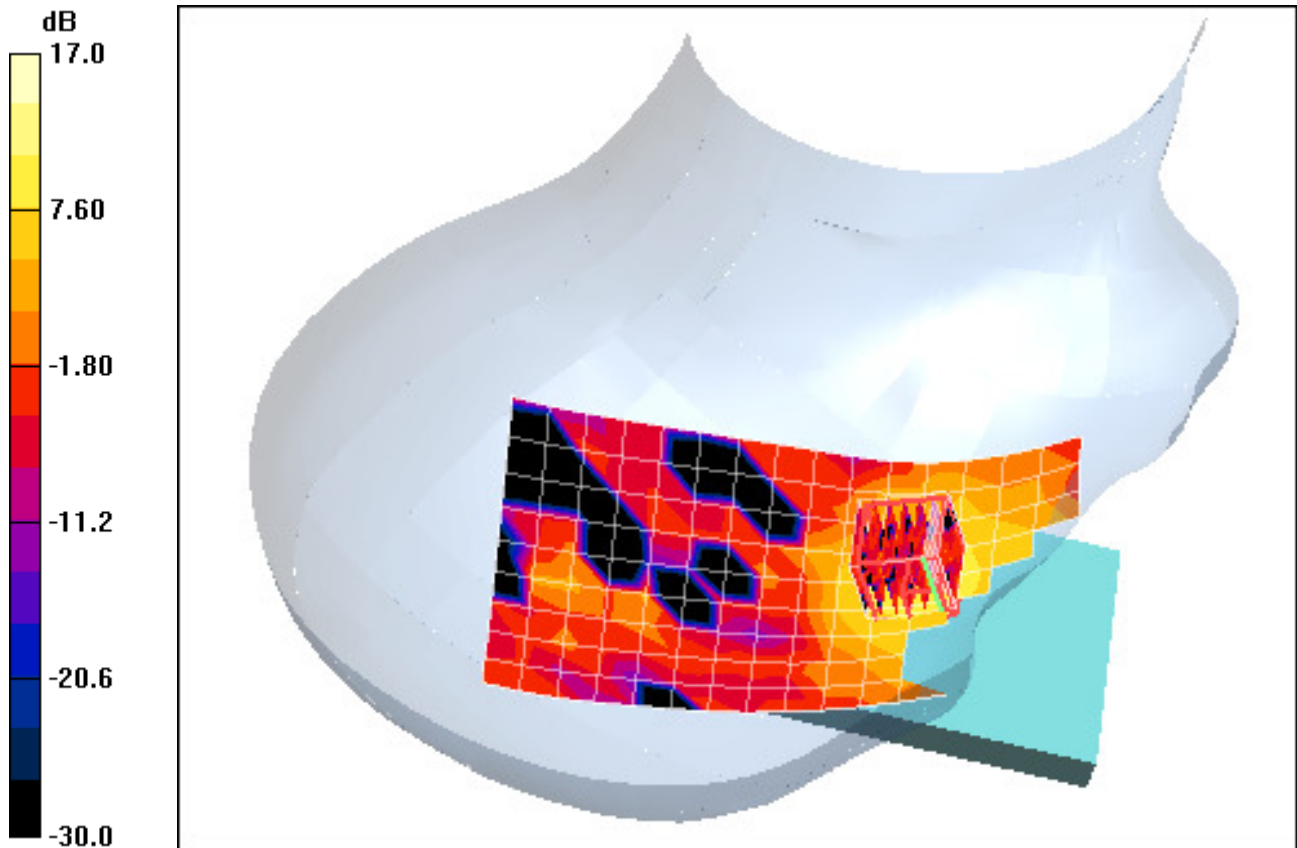

0 dB = 0.010mW/g

PCTEST ENGINEERING LABORATORY, INC.

**DUT: A3LSWDSC02C; Type: 850/1900 GSM/GPRS/EDGE Phone with Bluetooth and WLAN
Serial: FI-095-B**

Communication System: IEEE 802.11a 5.2-5.8 GHz Band; Frequency: 5260 MHz; Duty Cycle: 1:1
Medium: 5 GHz Head; Medium parameters used (interpolated):
 $f = 5260 \text{ MHz}$; $\sigma = 4.81 \text{ mho/m}$; $\epsilon_r = 37.1$; $\rho = 1000 \text{ kg/m}^3$
Phantom section: Left Section

Test Date: 05-04-2011; Ambient Temp: 24.3°C ; Tissue Temp: 22.8°C

Probe: EX3DV4 - SN3550; ConvF(3.92, 3.92, 3.92); Calibrated: 2/14/2011
Sensor-Surface: 2mm (Mechanical Surface Detection)
Electronics: DAE4 Sn859; Calibrated: 7/8/2010
Phantom: SAM Main; Type: SAM 4.0; Serial: TP-1114

Measurement SW: DASY4, V4.7 Build 80; Postprocessing SW: SEMCAD, V1.8 Build 186

Mode: IEEE 802.11a, 5.3 GHz Left Head, Touch, Ch 52, 6 Mbps

Area Scan (10x16x1): Measurement grid: dx=10mm, dy=10mm

Zoom Scan (7x7x11)/Cube 0: Measurement grid: dx=4mm, dy=4mm, dz=2mm

Reference Value = 1.82 V/m

Peak SAR (extrapolated) = 0.110 W/kg

SAR(1 g) = 0.018 mW/g; SAR(10 g) = 0.00625 mW/g

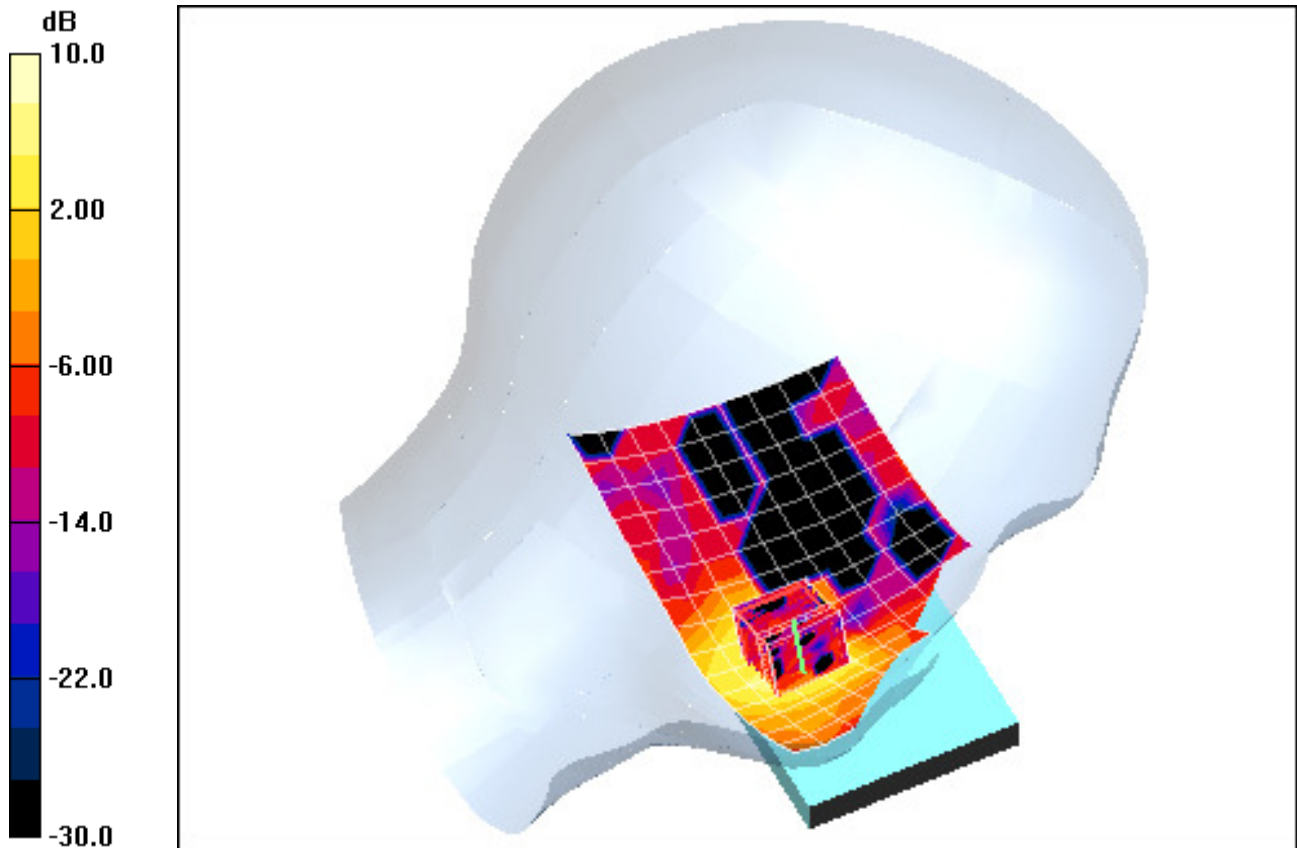

0 dB = 0.038mW/g

PCTEST ENGINEERING LABORATORY, INC.

**DUT: A3LSWDSC02C; Type: 850/1900 GSM/GPRS/EDGE Phone with Bluetooth and WLAN
Serial: FI-095-B**

Communication System: IEEE 802.11a 5.2-5.8 GHz Band; Frequency: 5260 MHz; Duty Cycle: 1:1
Medium: 5 GHz Head; Medium parameters used (interpolated):

$$f = 5260 \text{ MHz}; \sigma = 4.81 \text{ mho/m}; \epsilon_r = 37.1; \rho = 1000 \text{ kg/m}^3$$

Phantom section: Left Section

Test Date: 05-04-2011; Ambient Temp: 24.3°C ; Tissue Temp: 22.8°C

Probe: EX3DV4 - SN3550; ConvF(3.92, 3.92, 3.92); Calibrated: 2/14/2011

Sensor-Surface: 2mm (Mechanical Surface Detection)

Electronics: DAE4 Sn859; Calibrated: 7/8/2010

Phantom: SAM Main; Type: SAM 4.0; Serial: TP-1114

Measurement SW: DASY4, V4.7 Build 80; Postprocessing SW: SEMCAD, V1.8 Build 186

Mode: IEEE 802.11a, 5.3 GHz Left Head, Tilt, Ch 52, 6 Mbps

Area Scan (10x16x1): Measurement grid: dx=10mm, dy=10mm

Zoom Scan (7x7x11)/Cube 0: Measurement grid: dx=4mm, dy=4mm, dz=2mm

Reference Value = 0.898 V/m

Peak SAR (extrapolated) = 0.045 W/kg

SAR(1 g) = 0.00323 mW/g; SAR(10 g) = 0.00136 mW/g

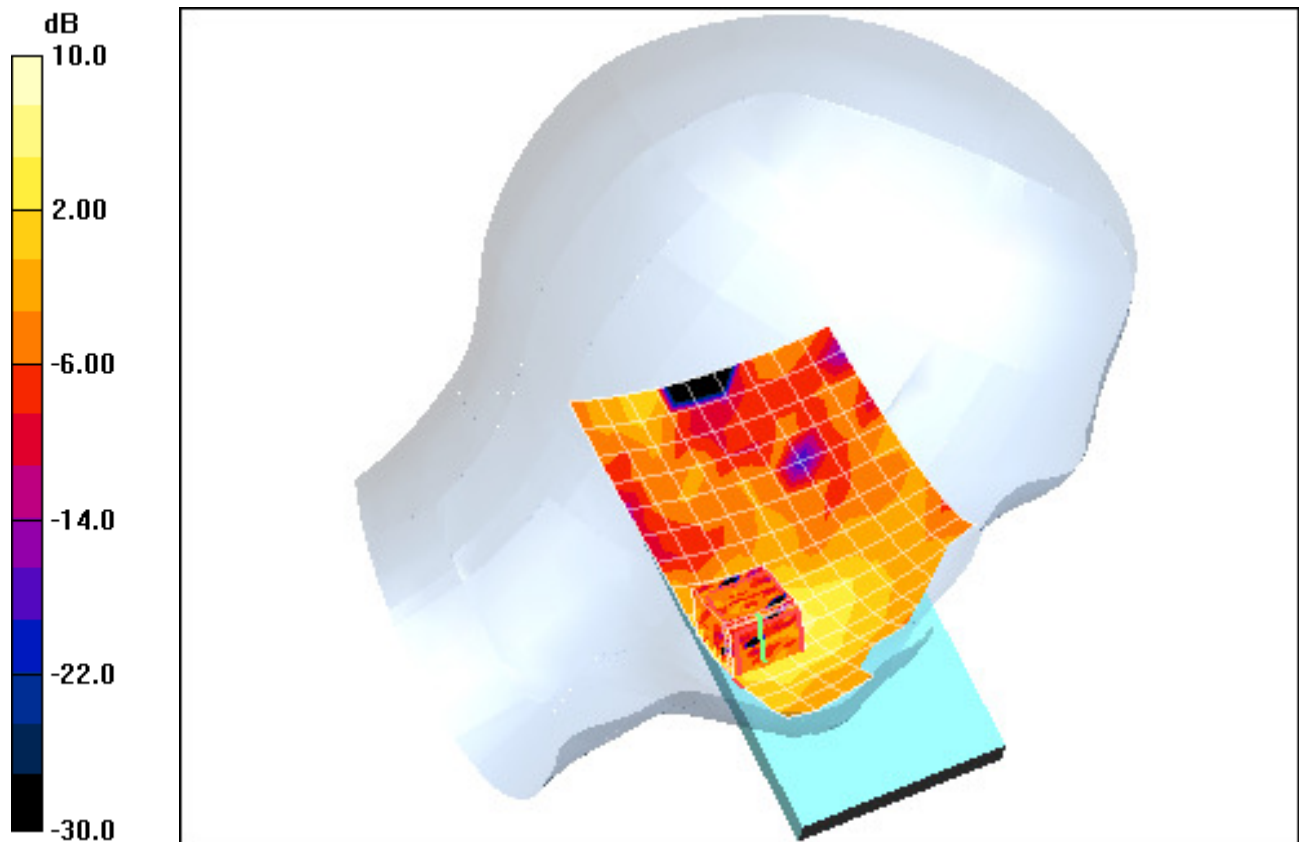

0 dB = 0.012mW/g

PCTEST ENGINEERING LABORATORY, INC.

**DUT: A3LSWDSC02C; Type: 850/1900 GSM/GPRS/EDGE Phone with Bluetooth and WLAN
Serial: FI-095-B**

Communication System: IEEE 802.11a 5.2-5.8 GHz Band; Frequency: 5700 MHz; Duty Cycle: 1:1
Medium: 5 GHz Head; Medium parameters used (interpolated):
 $f = 5700 \text{ MHz}$; $\sigma = 5.38 \text{ mho/m}$; $\epsilon_r = 36.3$; $\rho = 1000 \text{ kg/m}^3$
Phantom section: Right Section

Test Date: 05-04-2011; Ambient Temp: 23.4°C ; Tissue Temp: 22.5°C

Probe: EX3DV4 - SN3550; ConvF(3.64, 3.64, 3.64); Calibrated: 2/14/2011
Sensor-Surface: 2mm (Mechanical Surface Detection)
Electronics: DAE4 Sn859; Calibrated: 7/8/2010
Phantom: SAM Main; Type: SAM 4.0; Serial: TP-1114

Measurement SW: DASY4, V4.7 Build 80; Postprocessing SW: SEMCAD, V1.8 Build 186

Mode: IEEE 802.11a 5.5 GHz, Right Head, Touch, Ch 140, 6 Mbps

Area Scan (10x16x1): Measurement grid: dx=10mm, dy=10mm

Zoom Scan (7x7x11)/Cube 0: Measurement grid: dx=4mm, dy=4mm, dz=2mm

Reference Value = 6.41 V/m

Peak SAR (extrapolated) = 0.920 W/kg

SAR(1 g) = 0.227 mW/g; SAR(10 g) = 0.077 mW/g

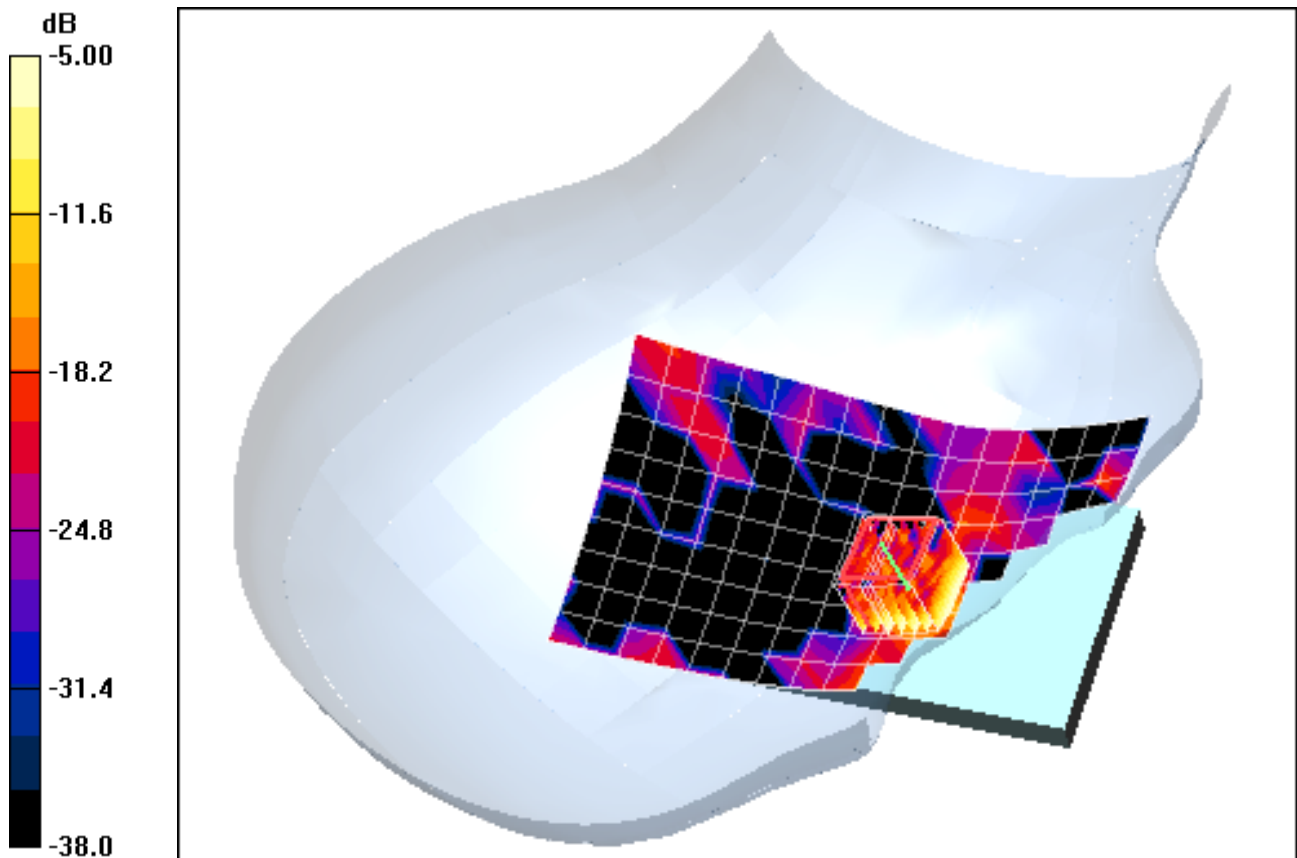

0 dB = 0.446mW/g

PCTEST ENGINEERING LABORATORY, INC.

**DUT: A3LSWDSC02C; Type: 850/1900 GSM/GPRS/EDGE Phone with Bluetooth and WLAN
Serial: FI-095-B**

Communication System: IEEE 802.11a 5.2-5.8 GHz Band; Frequency: 5700 MHz; Duty Cycle: 1:1
Medium: 5 GHz Head; Medium parameters used (interpolated):
 $f = 5700 \text{ MHz}$; $\sigma = 5.38 \text{ mho/m}$; $\epsilon_r = 36.3$; $\rho = 1000 \text{ kg/m}^3$
Phantom section: Right Section

Test Date: 05-04-2011; Ambient Temp: 23.4°C ; Tissue Temp: 22.5°C

Probe: EX3DV4 - SN3550; ConvF(3.64, 3.64, 3.64); Calibrated: 2/14/2011
Sensor-Surface: 2mm (Mechanical Surface Detection)
Electronics: DAE4 Sn859; Calibrated: 7/8/2010
Phantom: SAM Main; Type: SAM 4.0; Serial: TP-1114

Measurement SW: DASY4, V4.7 Build 80; Postprocessing SW: SEMCAD, V1.8 Build 186

Mode: IEEE 802.11a 5.5 GHz, Right Head, Tilt, Ch 140, 6 Mbps

Area Scan (10x16x1): Measurement grid: dx=10mm, dy=10mm

Zoom Scan (7x7x11)/Cube 0: Measurement grid: dx=4mm, dy=4mm, dz=2mm

Reference Value = 2.66 V/m

Peak SAR (extrapolated) = 0.161 W/kg

SAR(1 g) = 0.039 mW/g; SAR(10 g) = 0.016 mW/g



0 dB = 0.079mW/g

PCTEST ENGINEERING LABORATORY, INC.

**DUT: A3LSWDSC02C; Type: 850/1900 GSM/GPRS/EDGE Phone with Bluetooth and WLAN
Serial: FI-095-B**

Communication System: IEEE 802.11a 5.2-5.8 GHz Band; Frequency: 5700 MHz; Duty Cycle: 1:1
Medium: 5 GHz Head; Medium parameters used (interpolated):

$$f = 5700 \text{ MHz}; \sigma = 5.38 \text{ mho/m}; \epsilon_r = 36.3; \rho = 1000 \text{ kg/m}^3$$

Phantom section: Left Section

Test Date: 05-04-2011; Ambient Temp: 23.4°C ; Tissue Temp: 22.5°C

Probe: EX3DV4 - SN3550; ConvF(3.64, 3.64, 3.64); Calibrated: 2/14/2011

Sensor-Surface: 2mm (Mechanical Surface Detection)

Electronics: DAE4 Sn859; Calibrated: 7/8/2010

Phantom: SAM Main; Type: SAM 4.0; Serial: TP-1114

Measurement SW: DASY4, V4.7 Build 80; Postprocessing SW: SEMCAD, V1.8 Build 186

Mode: IEEE 802.11a, 5.5 GHz Left Head, Touch, Ch 140, 6 Mbps

Area Scan (10x16x1): Measurement grid: dx=10mm, dy=10mm

Zoom Scan (7x7x11)/Cube 0: Measurement grid: dx=4mm, dy=4mm, dz=2mm

Reference Value = 5.27 V/m

Peak SAR (extrapolated) = 0.462 W/kg

SAR(1 g) = 0.136 mW/g; SAR(10 g) = 0.050 mW/g

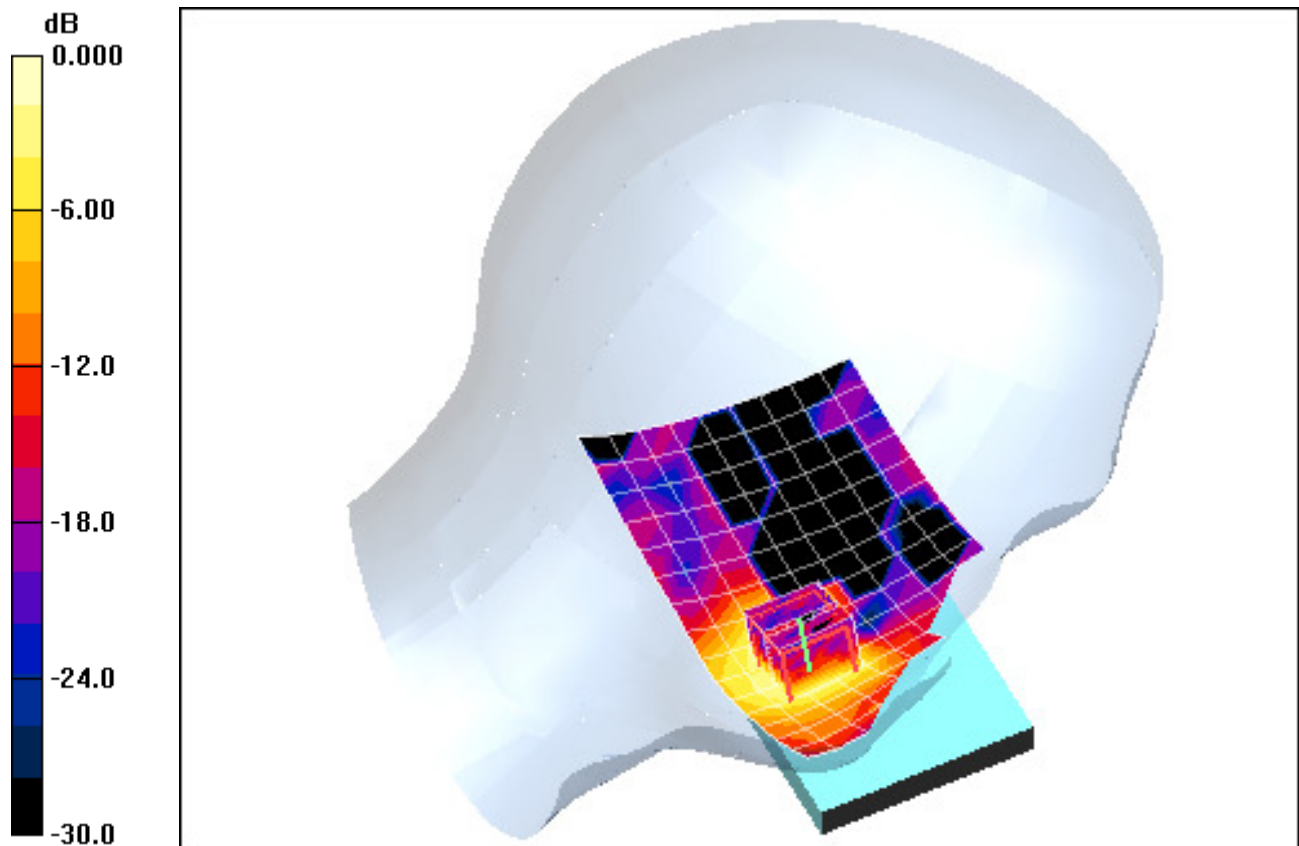

0 dB = 0.254mW/g

PCTEST ENGINEERING LABORATORY, INC.

**DUT: A3LSWDSC02C; Type: 850/1900 GSM/GPRS/EDGE Phone with Bluetooth and WLAN
Serial: FI-095-B**

Communication System: IEEE 802.11a 5.2-5.8 GHz Band; Frequency: 5700 MHz; Duty Cycle: 1:1
Medium: 5 GHz Head; Medium parameters used (interpolated):
 $f = 5700 \text{ MHz}$; $\sigma = 5.38 \text{ mho/m}$; $\epsilon_r = 36.3$; $\rho = 1000 \text{ kg/m}^3$
Phantom section: Left Section

Test Date: 05-04-2011; Ambient Temp: 23.4°C ; Tissue Temp: 22.5°C

Probe: EX3DV4 - SN3550; ConvF(3.64, 3.64, 3.64); Calibrated: 2/14/2011
Sensor-Surface: 2mm (Mechanical Surface Detection)
Electronics: DAE4 Sn859; Calibrated: 7/8/2010
Phantom: SAM Main; Type: SAM 4.0; Serial: TP-1114
Measurement SW: DASY4, V4.7 Build 80; Postprocessing SW: SEMCAD, V1.8 Build 186

Mode: IEEE 802.11a, 5.5 GHz Left Head, Tilt, Ch 140, 6 Mbps

Area Scan (10x16x1): Measurement grid: dx=10mm, dy=10mm
Zoom Scan (7x7x11)/Cube 0: Measurement grid: dx=4mm, dy=4mm, dz=2mm
Reference Value = 2.43 V/m
Peak SAR (extrapolated) = 0.207 W/kg
SAR(1 g) = 0.036 mW/g; SAR(10 g) = 0.015 mW/g

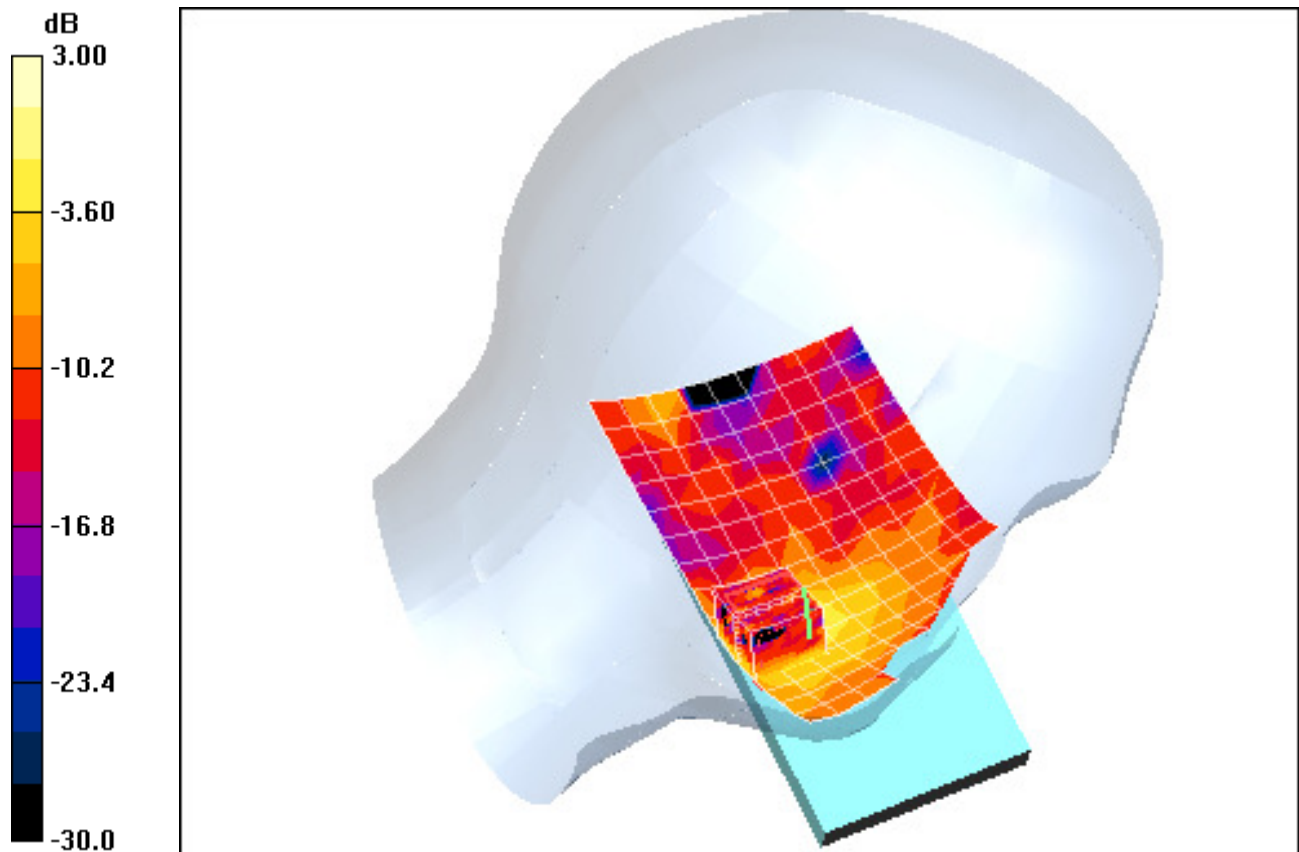

0 dB = 0.071mW/g

PCTEST ENGINEERING LABORATORY, INC.

**DUT: A3LSWDSC02C; Type: 850/1900 GSM/GPRS/EDGE Phone with Bluetooth and WLAN
Serial: FI-095-B**

Communication System: IEEE 802.11a 5.2-5.8 GHz Band; Frequency: 5805 MHz; Duty Cycle: 1:1
Medium: 5 GHz Head Medium parameters used (interpolated):

$$f = 5745 \text{ MHz}; \sigma = 5.43 \text{ mho/m}; \epsilon_r = 36.1; \rho = 1000 \text{ kg/m}^3$$

Phantom section: Right Section

Test Date: 05-04-2011; Ambient Temp: 23.9°C ; Tissue Temp: 22.8°C

Probe: EX3DV4 - SN3550; ConvF(3.64, 3.64, 3.64); Calibrated: 2/14/2011

Sensor-Surface: 2mm (Mechanical Surface Detection)

Electronics: DAE4 Sn859; Calibrated: 7/8/2010

Phantom: SAM Main; Type: SAM 4.0; Serial: TP-1114

Measurement SW: DASY4, V4.7 Build 80; Postprocessing SW: SEMCAD, V1.8 Build 186

Mode: IEEE 802.11a 5.8 GHz, Right Head, Touch, Ch 149, 6 Mbps

Area Scan (10x16x1): Measurement grid: dx=10mm, dy=10mm

Zoom Scan (7x7x11)/Cube 0: Measurement grid: dx=4mm, dy=4mm, dz=2mm

Reference Value = 7.43 V/m

Peak SAR (extrapolated) = 1.30 W/kg

SAR(1 g) = 0.291 mW/g; SAR(10 g) = 0.095 mW/g

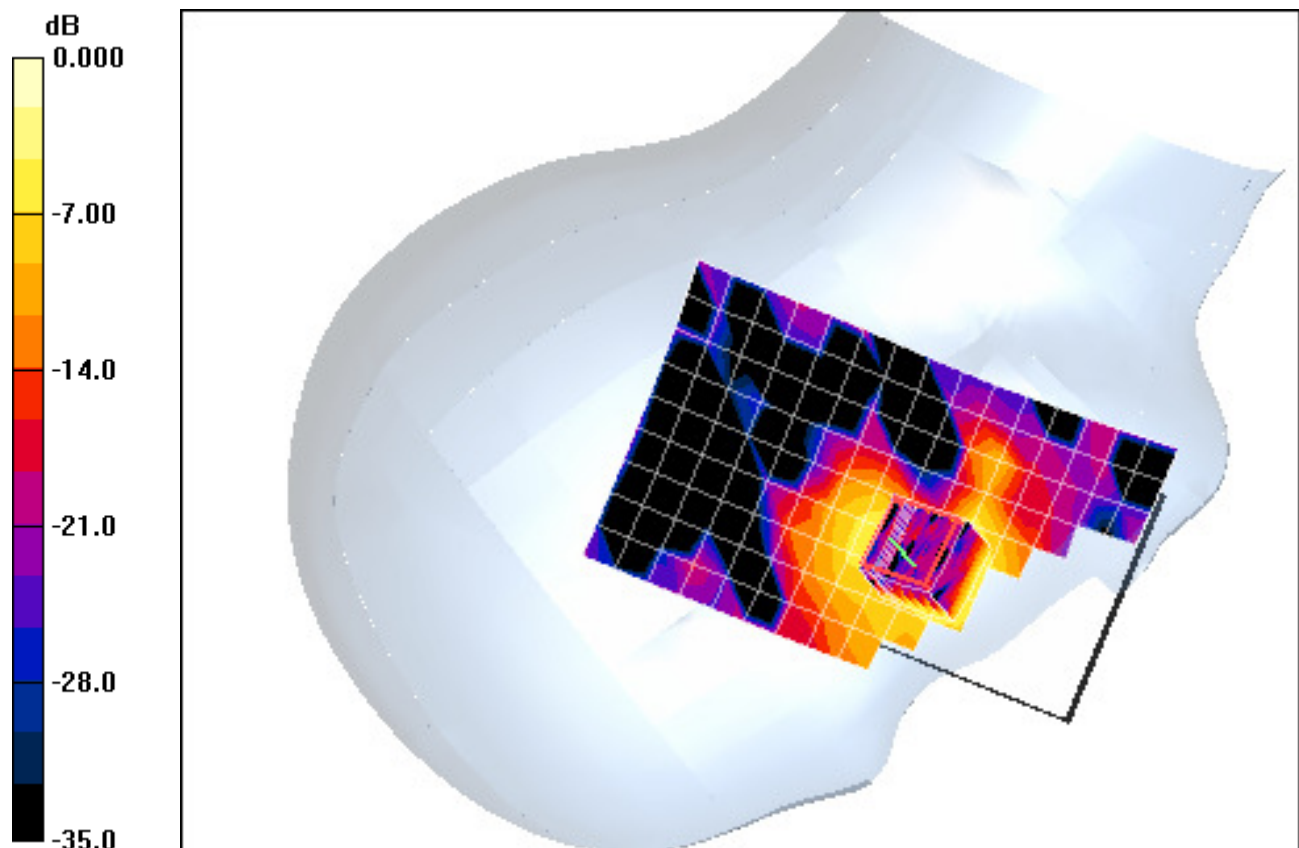

0 dB = 0.566mW/g

PCTEST ENGINEERING LABORATORY, INC.

**DUT: A3LSWDSC02C; Type: 850/1900 GSM/GPRS/EDGE Phone with Bluetooth and WLAN
Serial: FI-095-B**

Communication System: IEEE 802.11a 5.2-5.8 GHz Band; Frequency: 5805 MHz; Duty Cycle: 1:1
Medium: 5 GHz Head Medium parameters used (interpolated):

$$f = 5745 \text{ MHz}; \sigma = 5.43 \text{ mho/m}; \epsilon_r = 36.1; \rho = 1000 \text{ kg/m}^3$$

Phantom section: Right Section

Test Date: 05-04-2011; Ambient Temp: 23.9°C ; Tissue Temp: 22.8°C

Probe: EX3DV4 - SN3550; ConvF(3.64, 3.64, 3.64); Calibrated: 2/14/2011

Sensor-Surface: 2mm (Mechanical Surface Detection)

Electronics: DAE4 Sn859; Calibrated: 7/8/2010

Phantom: SAM Main; Type: SAM 4.0; Serial: TP-1114

Measurement SW: DASY4, V4.7 Build 80; Postprocessing SW: SEMCAD, V1.8 Build 186

Mode: IEEE 802.11a 5.8 GHz, Right Head, Touch, Ch 149, 6 Mbps

Area Scan (10x16x1): Measurement grid: dx=10mm, dy=10mm

Zoom Scan (7x7x11)/Cube 0: Measurement grid: dx=4mm, dy=4mm, dz=2mm

Reference Value = 7.43 V/m

Peak SAR (extrapolated) = 1.30 W/kg

SAR(1 g) = 0.291 mW/g; SAR(10 g) = 0.095 mW/g

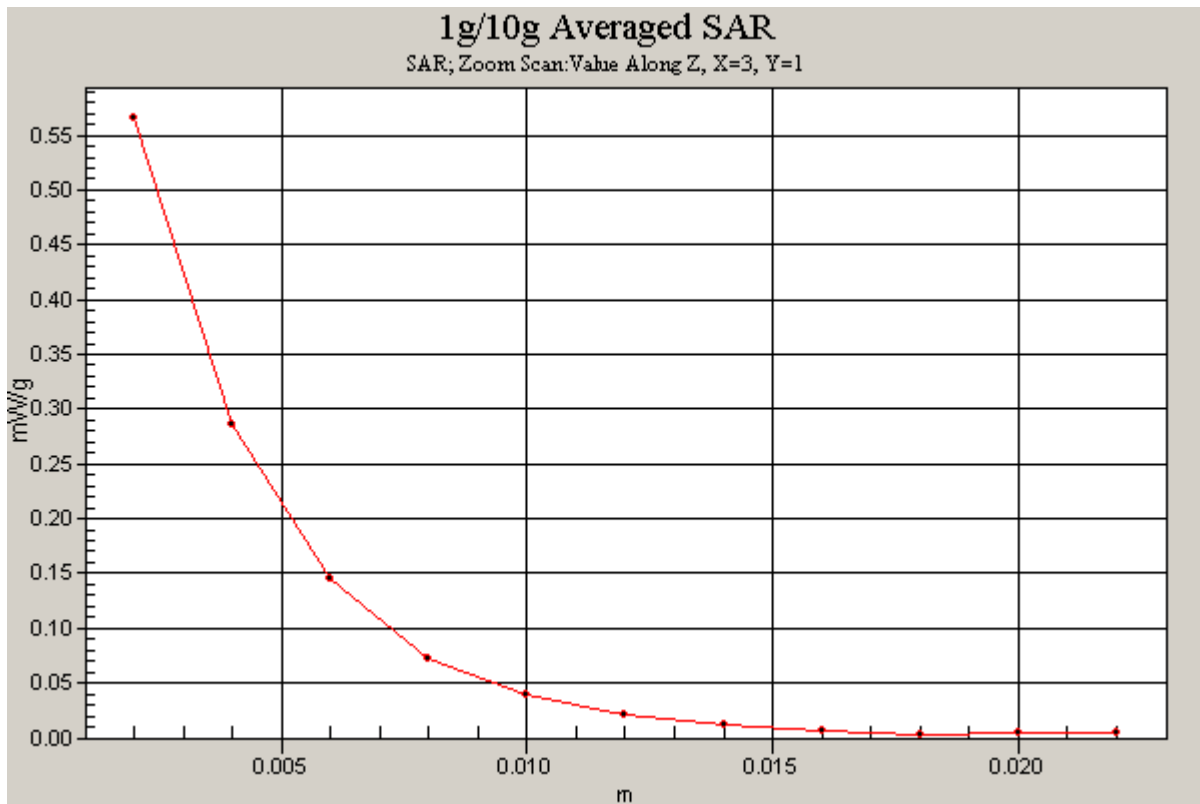

PCTEST ENGINEERING LABORATORY, INC.

**DUT: A3LSWDSC02C; Type: 850/1900 GSM/GPRS/EDGE Phone with Bluetooth and WLAN
Serial: FI-095-B**

Communication System: IEEE 802.11a 5.2-5.8 GHz Band; Frequency: 5745 MHz; Duty Cycle: 1:1
Medium: 5 GHz Head; Medium parameters used (interpolated):

$$f = 5745 \text{ MHz}; \sigma = 5.43 \text{ mho/m}; \epsilon_r = 36.1; \rho = 1000 \text{ kg/m}^3$$

Phantom section: Right Section

Test Date: 05-04-2011; Ambient Temp: 23.9°C ; Tissue Temp: 22.8°C

Probe: EX3DV4 - SN3550; ConvF(3.64, 3.64, 3.64); Calibrated: 2/14/2011

Sensor-Surface: 2mm (Mechanical Surface Detection)

Electronics: DAE4 Sn859; Calibrated: 7/8/2010

Phantom: SAM Main; Type: SAM 4.0; Serial: TP-1114

Measurement SW: DASY4, V4.7 Build 80; Postprocessing SW: SEMCAD, V1.8 Build 186

Mode: IEEE 802.11a 5.8 GHz, Right Head, Tilt, Ch 149, 6 Mbps

Area Scan (10x16x1): Measurement grid: dx=10mm, dy=10mm

Zoom Scan (7x7x11)/Cube 0: Measurement grid: dx=4mm, dy=4mm, dz=2mm

Reference Value = 2.90 V/m

Peak SAR (extrapolated) = 0.249 W/kg

SAR(1 g) = 0.037 mW/g; SAR(10 g) = 0.016 mW/g

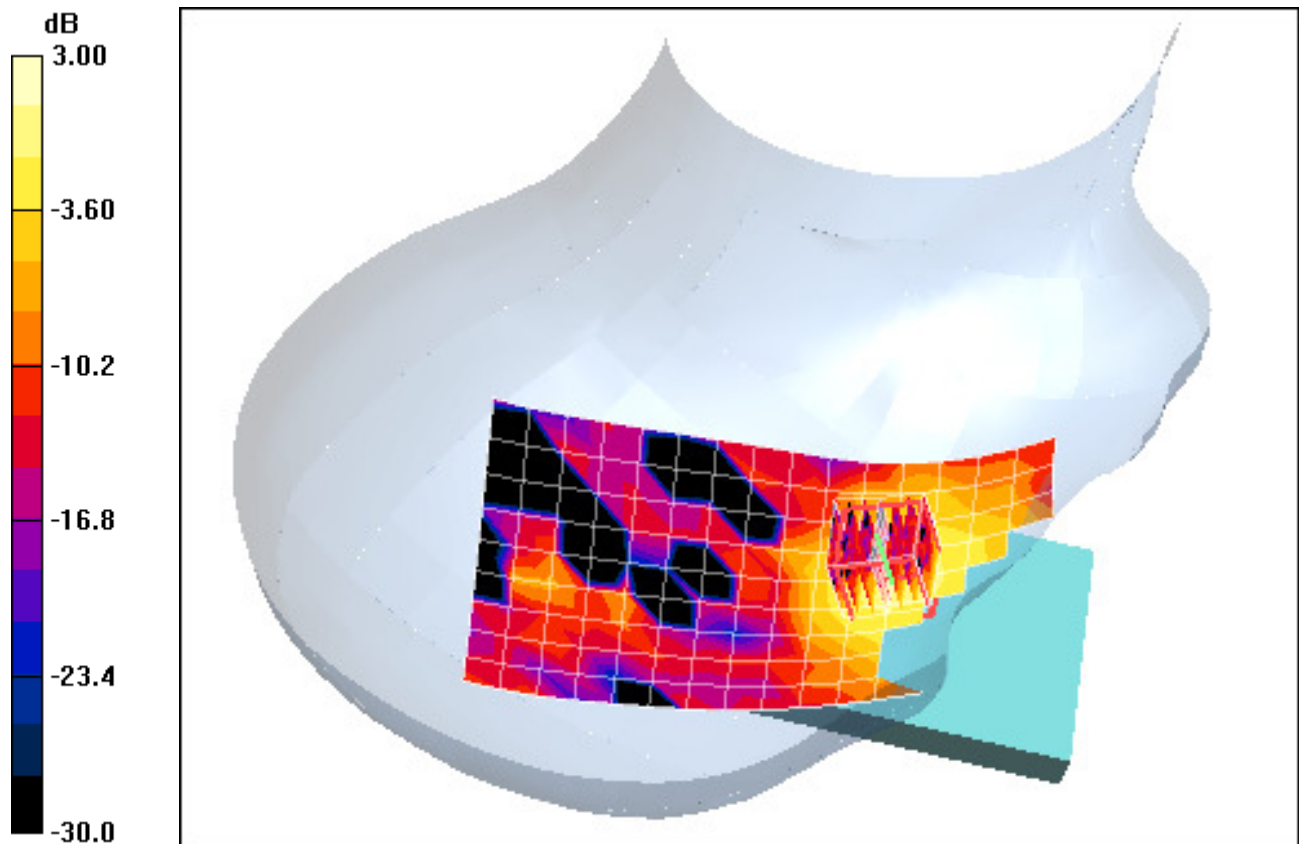

0 dB = 0.086mW/g

PCTEST ENGINEERING LABORATORY, INC.

**DUT: A3LSWDSC02C; Type: 850/1900 GSM/GPRS/EDGE Phone with Bluetooth and WLAN
Serial: FI-095-B**

Communication System: IEEE 802.11a 5.2-5.8 GHz Band; Frequency: 5745 MHz; Duty Cycle: 1:1
Medium: 5 GHz Head; Medium parameters used (interpolated):
 $f = 5745 \text{ MHz}$; $\sigma = 5.43 \text{ mho/m}$; $\epsilon_r = 36.1$; $\rho = 1000 \text{ kg/m}^3$
Phantom section: Left Section

Test Date: 05-04-2011; Ambient Temp: 23.9°C ; Tissue Temp: 22.8°C

Probe: EX3DV4 - SN3550; ConvF(3.64, 3.64, 3.64); Calibrated: 2/14/2011

.....Sensor-Surface: 2mm (Mechanical Surface Detection)

Electronics: DAE4 Sn859; Calibrated: 7/8/2010

Phantom: SAM Main; Type: SAM 4.0; Serial: TP-1114

Measurement SW: DASY4, V4.7 Build 80; Postprocessing SW: SEMCAD, V1.8 Build 186

Mode: IEEE 802.11a, 5.8 GHz Left Head, Touch, Ch 149, 6 Mbps

Area Scan (10x16x1): Measurement grid: dx=10mm, dy=10mm

Zoom Scan (7x7x11)/Cube 0: Measurement grid: dx=4mm, dy=4mm, dz=2mm

Reference Value = 6.28 V/m

Peak SAR (extrapolated) = 0.697 W/kg

SAR(1 g) = 0.192 mW/g; SAR(10 g) = 0.066 mW/g

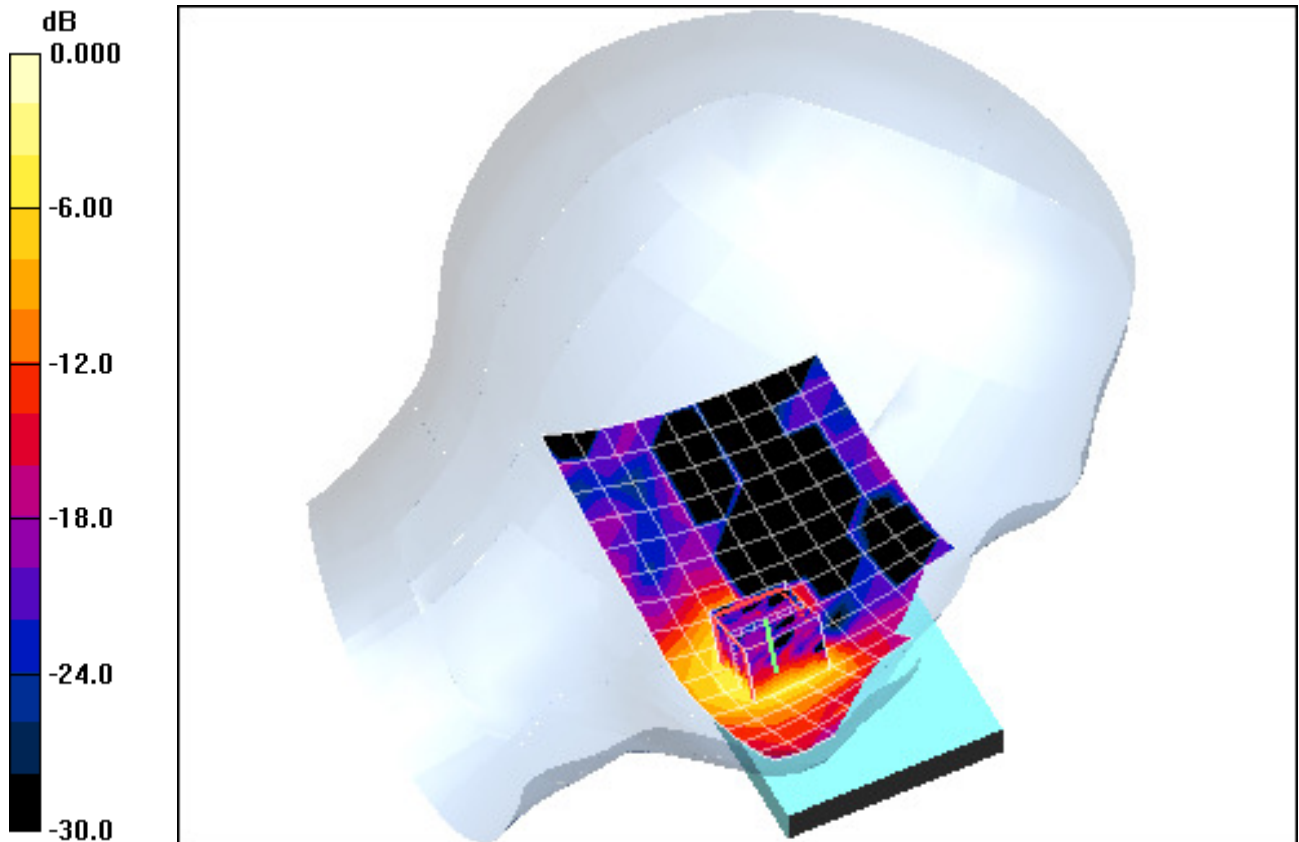

0 dB = 0.386mW/g

PCTEST ENGINEERING LABORATORY, INC.

**DUT: A3LSWDSC02C; Type: 850/1900 GSM/GPRS/EDGE Phone with Bluetooth and WLAN
Serial: FI-095-B**

Communication System: IEEE 802.11a 5.2-5.8 GHz Band; Frequency: 5745 MHz; Duty Cycle: 1:1
Medium: 5 GHz Head; Medium parameters used (interpolated):
 $f = 5745 \text{ MHz}; \sigma = 5.43 \text{ mho/m}; \epsilon_r = 36.1; \rho = 1000 \text{ kg/m}^3$
Phantom section: Left Section

Test Date: 05-04-2011; Ambient Temp: 23.9°C ; Tissue Temp: 22.8°C

Probe: EX3DV4 - SN3550; ConvF(3.64, 3.64, 3.64); Calibrated: 2/14/2011

.....Sensor-Surface: 2mm (Mechanical Surface Detection)

Electronics: DAE4 Sn859; Calibrated: 7/8/2010

Phantom: SAM Main; Type: SAM 4.0; Serial: TP-1114

Measurement SW: DASY4, V4.7 Build 80; Postprocessing SW: SEMCAD, V1.8 Build 186

Mode: IEEE 802.11a, 5.8 GHz Left Head, Tilt, Ch 149, 6 Mbps

Area Scan (10x16x1): Measurement grid: dx=10mm, dy=10mm

Zoom Scan (7x7x11)/Cube 0: Measurement grid: dx=4mm, dy=4mm, dz=2mm

Reference Value = 2.41 V/m

Peak SAR (extrapolated) = 0.214 W/kg

SAR(1 g) = 0.030 mW/g; SAR(10 g) = 0.012 mW/g

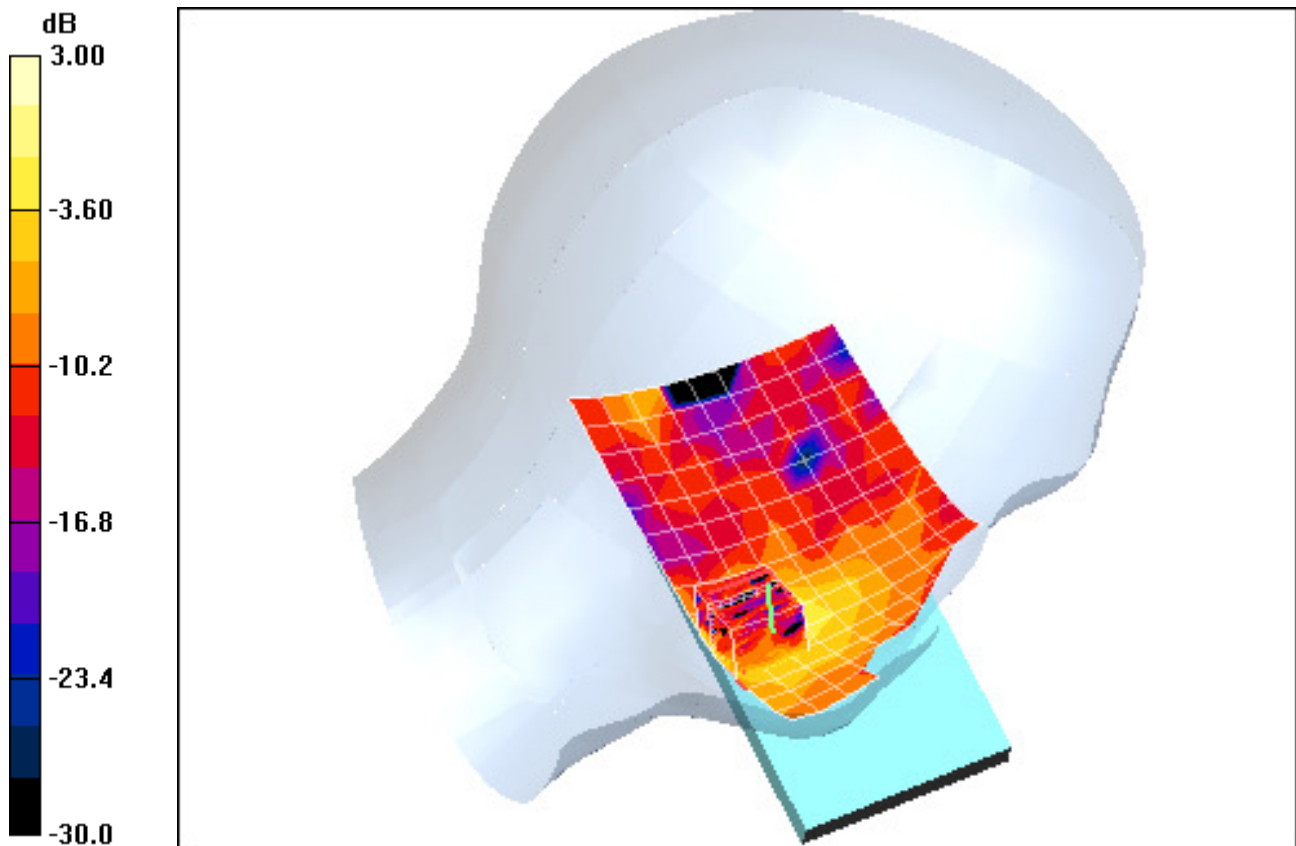

0 dB = 0.067mW/g

PCTEST ENGINEERING LABORATORY, INC.

**DUT: A3LSWDSC02C; Type: 850/1900 GSM/GPRS/EDGE Phone with Bluetooth and WLAN
Serial: FI-095-A**

Communication System: GSM850 GPRS; 5 Tx slots; Frequency: 836.6 MHz; Duty Cycle: 1:2.76
Medium: 835 Body; Medium parameters used (interpolated):
 $f = 836.6 \text{ MHz}$; $\sigma = 0.958 \text{ mho/m}$; $\epsilon_r = 53.13$; $\rho = 1000 \text{ kg/m}^3$
Phantom section: Flat Section; Space: 1.0 cm

Test Date: 05-04-2011; Ambient Temp: 24.2°C; Tissue Temp: 22.4°C

Probe: EX3DV4 - SN3561; ConvF(8.09, 8.09, 8.09); Calibrated: 8/19/2010
Sensor-Surface: 4mm (Mechanical Surface Detection)
Electronics: DAE4 Sn649; Calibrated: 2/21/2011
Phantom: SAM Main; Type: SAM 4.0; Serial: TP-1406

Measurement SW: DASY4, V4.7 Build 80; Postprocessing SW: SEMCAD, V1.8 Build 186

Mode: GPRS 850, Body SAR, Back side, Mid.ch, 3 Tx Slots

Area Scan (7x10x1): Measurement grid: dx=15mm, dy=15mm

Zoom Scan (5x5x7)/Cube 0: Measurement grid: dx=8mm, dy=8mm, dz=5mm

Reference Value = 27.2 V/m

Peak SAR (extrapolated) = 0.881 W/kg

SAR(1 g) = 0.693 mW/g; SAR(10 g) = 0.520 mW/g

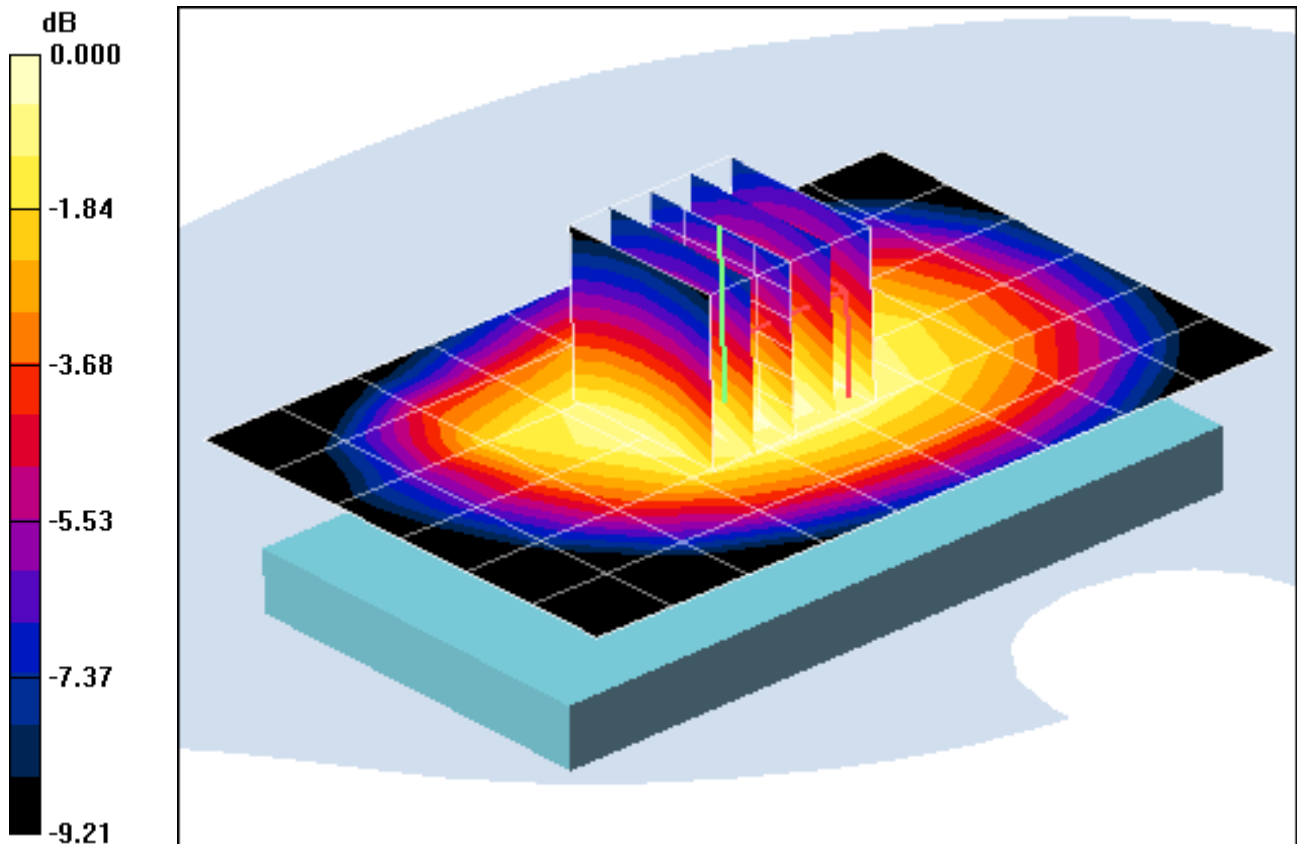

0 dB = 0.725mW/g

PCTEST ENGINEERING LABORATORY, INC.

**DUT: A3LSWDSC02C; Type: 850/1900 GSM/GPRS/EDGE Phone with Bluetooth and WLAN
Serial: FI-095-A**

Communication System: GSM850 GPRS; 5 Tx slots; Frequency: 836.6 MHz; Duty Cycle: 1:2.76
Medium: 835 Body; Medium parameters used (interpolated):
 $f = 836.6 \text{ MHz}$; $\sigma = 0.958 \text{ mho/m}$; $\epsilon_r = 53.13$; $\rho = 1000 \text{ kg/m}^3$
Phantom section: Flat Section; Space: 1.0 cm

Test Date: 05-04-2011; Ambient Temp: 24.2°C; Tissue Temp: 22.4°C

Probe: EX3DV4 - SN3561; ConvF(8.09, 8.09, 8.09); Calibrated: 8/19/2010
Sensor-Surface: 4mm (Mechanical Surface Detection)
Electronics: DAE4 Sn649; Calibrated: 2/21/2011
Phantom: SAM Main; Type: SAM 4.0; Serial: TP-1406

Measurement SW: DASY4, V4.7 Build 80; Postprocessing SW: SEMCAD, V1.8 Build 186

Mode: GPRS 850, Body SAR, Back side, Mid.ch, 3 Tx Slots

Area Scan (7x10x1): Measurement grid: dx=15mm, dy=15mm

Zoom Scan (5x5x7)/Cube 0: Measurement grid: dx=8mm, dy=8mm, dz=5mm

Reference Value = 27.2 V/m

Peak SAR (extrapolated) = 0.881 W/kg

SAR(1 g) = 0.693 mW/g; SAR(10 g) = 0.520 mW/g

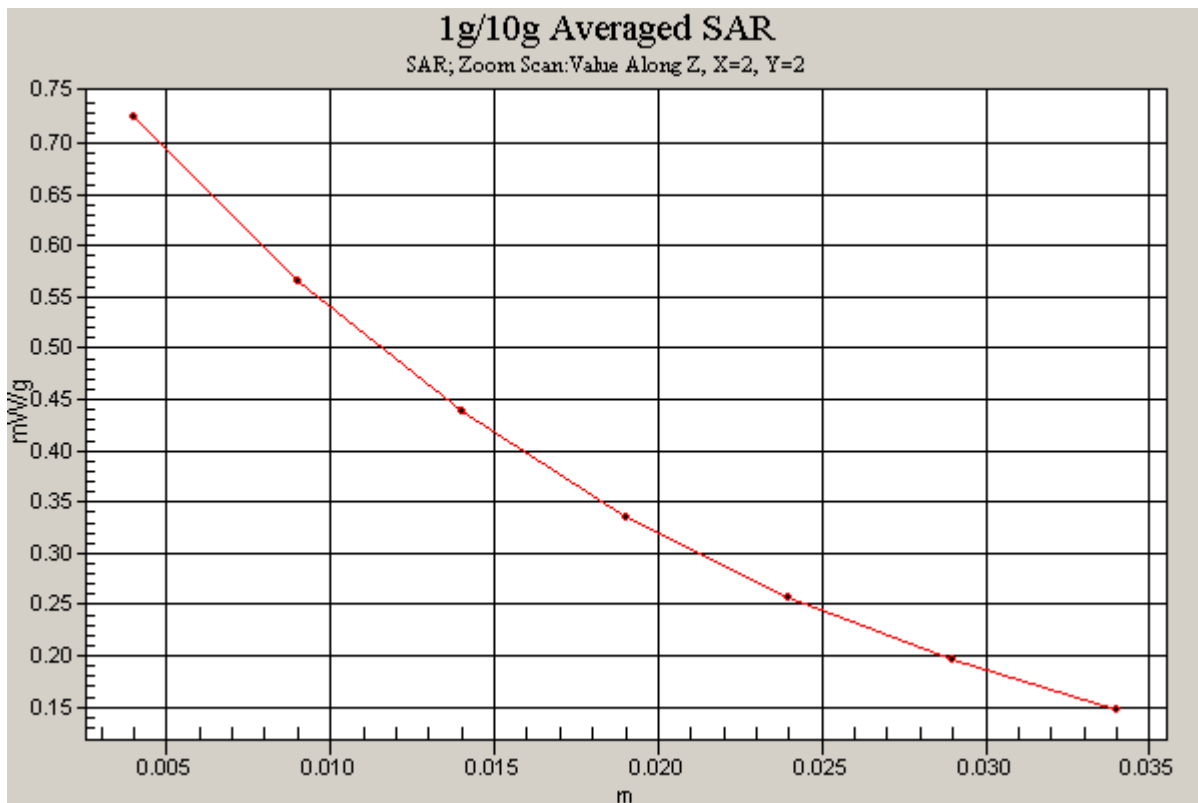

PCTEST ENGINEERING LABORATORY, INC.

**DUT: A3LSWDSC02C; Type: 850/1900 GSM/GPRS/EDGE Phone with Bluetooth and WLAN
Serial: FI-095-A**

Communication System: GSM850 GPRS;5 Tx slots; Frequency: 836.6 MHz;Duty Cycle: 1:4.98
Medium: 835 Body; Medium parameters used (interpolated):
 $f = 836.6 \text{ MHz}$; $\sigma = 0.958 \text{ mho/m}$; $\epsilon_r = 53.13$; $\rho = 1000 \text{ kg/m}^3$
Phantom section: Flat Section; Space: 1.0 cm

Test Date: 05-04-2011; Ambient Temp: 24.2°C; Tissue Temp: 22.4°C

Probe: EX3DV4 - SN3561; ConvF(8.09, 8.09, 8.09); Calibrated: 8/19/2010
Sensor-Surface: 4mm (Mechanical Surface Detection)
Electronics: DAE4 Sn649; Calibrated: 2/21/2011
Phantom: SAM Main; Type: SAM 4.0; Serial: TP-1406
Measurement SW: DASY4, V4.7 Build 80; Postprocessing SW: SEMCAD, V1.8 Build 186

Mode: GPRS 850, Body SAR, Front side, Mid.ch, 3 Tx Slots

Area Scan (7x10x1): Measurement grid: dx=15mm, dy=15mm

Zoom Scan (5x5x7)/Cube 0: Measurement grid: dx=8mm, dy=8mm, dz=5mm

Reference Value = 23.5 V/m

Peak SAR (extrapolated) = 0.643 W/kg

SAR(1 g) = 0.511 mW/g; SAR(10 g) = 0.391 mW/g

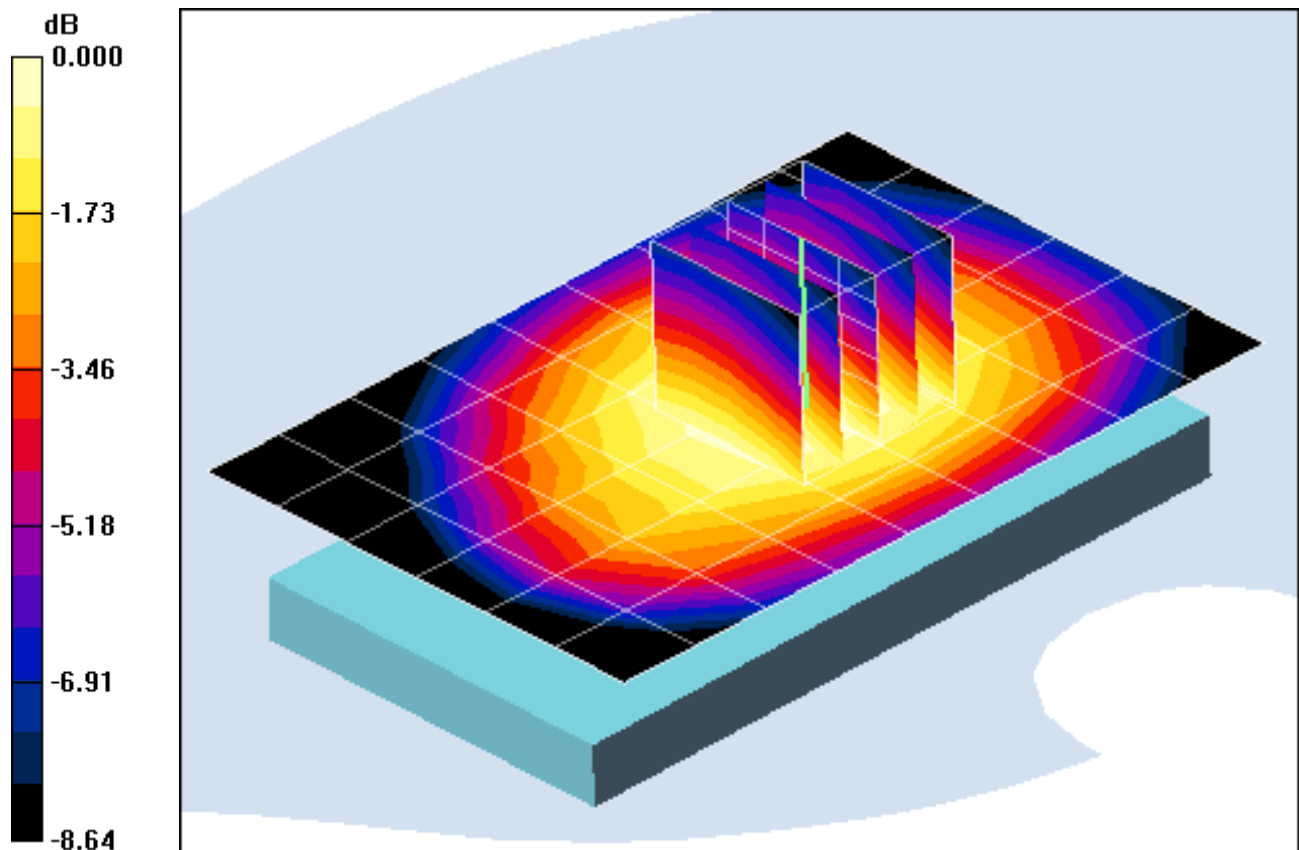

0 dB = 0.534mW/g

PCTEST ENGINEERING LABORATORY, INC.

**DUT: A3LSWDSC02C; Type: 850/1900 GSM/GPRS/EDGE Phone with Bluetooth and WLAN
Serial: FI-095-A**

Communication System: GSM850 GPRS; 5 Tx slots; Frequency: 836.6 MHz; Duty Cycle: 1:4.98
Medium: 835 Body; Medium parameters used (interpolated):
 $f = 836.6 \text{ MHz}$; $\sigma = 0.958 \text{ mho/m}$; $\epsilon_r = 53.13$; $\rho = 1000 \text{ kg/m}^3$
Phantom section: Flat Section; Space: 1.0 cm

Test Date: 05-04-2011; Ambient Temp: 24.2°C; Tissue Temp: 22.4°C

Probe: EX3DV4 - SN3561; ConvF(8.09, 8.09, 8.09); Calibrated: 8/19/2010
Sensor-Surface: 4mm (Mechanical Surface Detection)
Electronics: DAE4 Sn649; Calibrated: 2/21/2011
Phantom: SAM Main; Type: SAM 4.0; Serial: TP-1406

Measurement SW: DASY4, V4.7 Build 80; Postprocessing SW: SEMCAD, V1.8 Build 186

Mode: GPRS 850, Body SAR, Bottom Edge, Mid.ch, 3 Tx Slots

Area Scan (5x7x1): Measurement grid: dx=15mm, dy=15mm

Zoom Scan (5x5x7)/Cube 0: Measurement grid: dx=8mm, dy=8mm, dz=5mm

Reference Value = 17.2 V/m

Peak SAR (extrapolated) = 0.468 W/kg

SAR(1 g) = 0.258 mW/g; SAR(10 g) = 0.148 mW/g

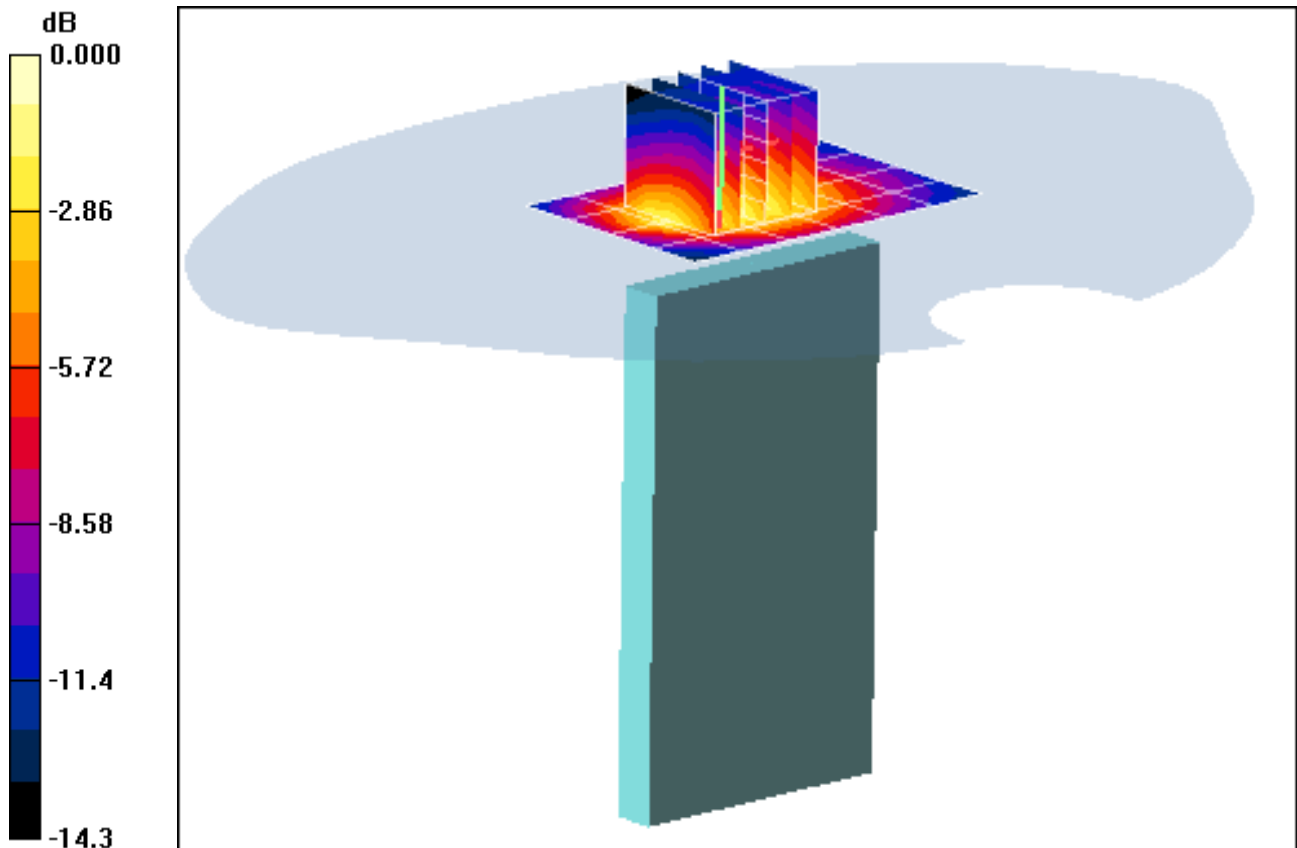

0 dB = 0.288mW/g

PCTEST ENGINEERING LABORATORY, INC.

**DUT: A3LSWDSC02C; Type: 850/1900 GSM/GPRS/EDGE Phone with Bluetooth and WLAN
Serial: FI-095-A**

Communication System: GSM850 GPRS; 5 Tx slots; Frequency: 836.6 MHz; Duty Cycle: 1:4.98
Medium: 835 Body; Medium parameters used (interpolated):
 $f = 836.6 \text{ MHz}$; $\sigma = 0.958 \text{ mho/m}$; $\epsilon_r = 53.13$; $\rho = 1000 \text{ kg/m}^3$
Phantom section: Flat Section; Space: 1.0 cm

Test Date: 05-04-2011; Ambient Temp: 24.2°C; Tissue Temp: 22.4°C

Probe: EX3DV4 - SN3561; ConvF(8.09, 8.09, 8.09); Calibrated: 8/19/2010
Sensor-Surface: 4mm (Mechanical Surface Detection)
Electronics: DAE4 Sn649; Calibrated: 2/21/2011
Phantom: SAM Main; Type: SAM 4.0; Serial: TP-1406

Measurement SW: DASY4, V4.7 Build 80; Postprocessing SW: SEMCAD, V1.8 Build 186

Mode: GPRS 850, Body SAR, Right Edge, Mid.ch, 3 Tx Slots

Area Scan (5x13x1): Measurement grid: dx=15mm, dy=15mm

Zoom Scan (5x5x7)/Cube 0: Measurement grid: dx=8mm, dy=8mm, dz=5mm

Reference Value = 26.4 V/m

Peak SAR (extrapolated) = 0.921 W/kg

SAR(1 g) = 0.640 mW/g; SAR(10 g) = 0.435 mW/g

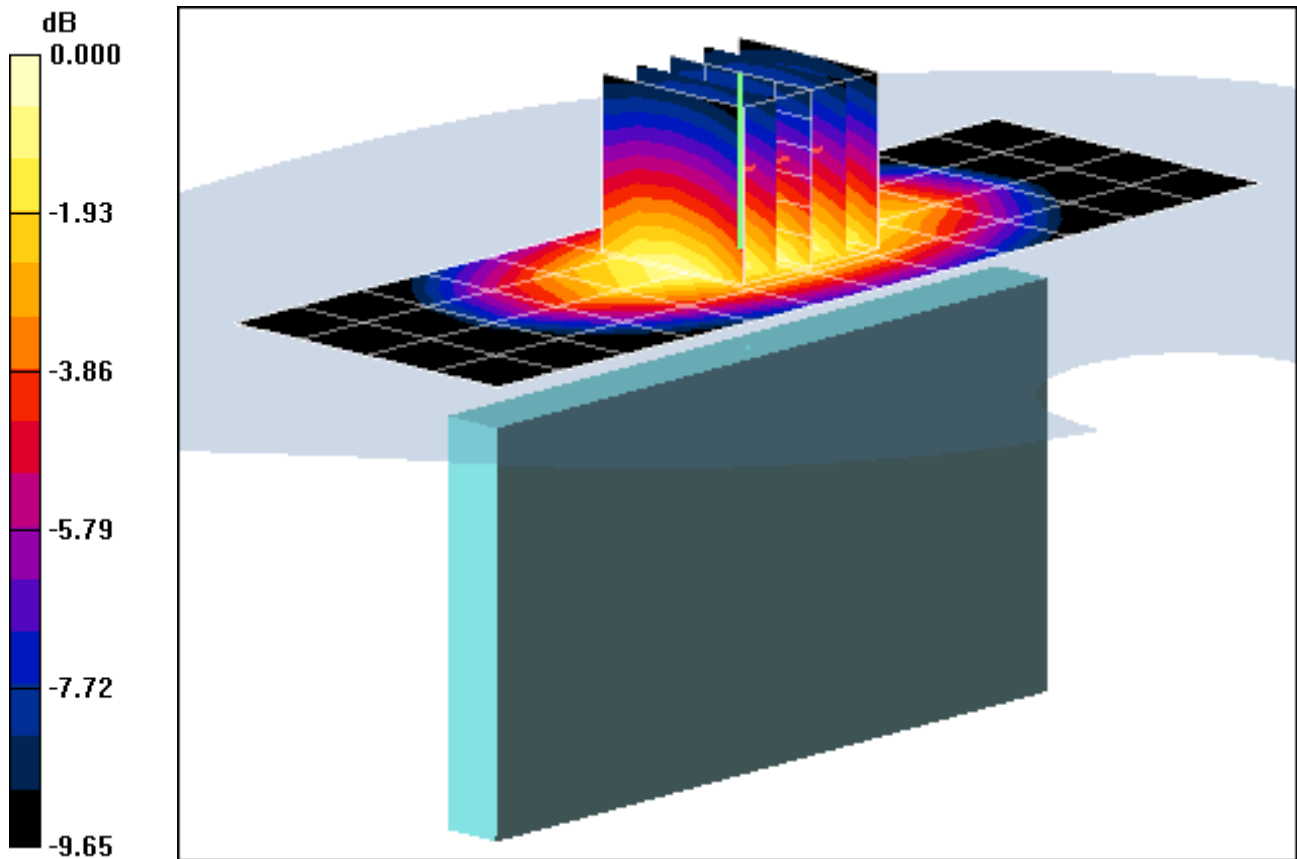

0 dB = 0.688mW/g

PCTEST ENGINEERING LABORATORY, INC.

**DUT: A3LSWDSC02C; Type: 850/1900 GSM/GPRS/EDGE Phone with Bluetooth and WLAN;
Serial: FI-095-A**

Communication System: GSM1900 GPRS; 2 Tx slots; Frequency: 1880 MHz; Duty Cycle: 1:4.15

Medium: 1900 Body Medium parameters used:

$$f = 1880 \text{ MHz}; \sigma = 1.53 \text{ mho/m}; \epsilon_r = 52.6; \rho = 1000 \text{ kg/m}^3$$

Phantom section: Flat Section; Space: 1.0 cm

Test Date: 05-03-2011; Ambient Temp: 23.3°C; Tissue Temp: 22.2°C

Probe: EX3DV4 - SN3561; ConvF(6.59, 6.59, 6.59); Calibrated: 8/19/2010

Sensor-Surface: 4mm (Mechanical Surface Detection)

Electronics: DAE4 Sn649; Calibrated: 2/21/2011

Phantom: SAM Sub; Type: SAM 4.0; Serial: TP-1357

Measurement SW: DASY4, V4.7 Build 80; Postprocessing SW: SEMCAD, V1.8 Build 186

Mode: GPRS 1900, Body SAR, Back side, Mid.ch, 2 Tx Slots

Area Scan (7x10x1): Measurement grid: dx=15mm, dy=15mm

Zoom Scan (5x5x7)/Cube 0: Measurement grid: dx=8mm, dy=8mm, dz=5mm

Reference Value = 19.2 V/m

Peak SAR (extrapolated) = 1.22 W/kg

SAR(1 g) = 0.690 mW/g; SAR(10 g) = 0.364 mW/g

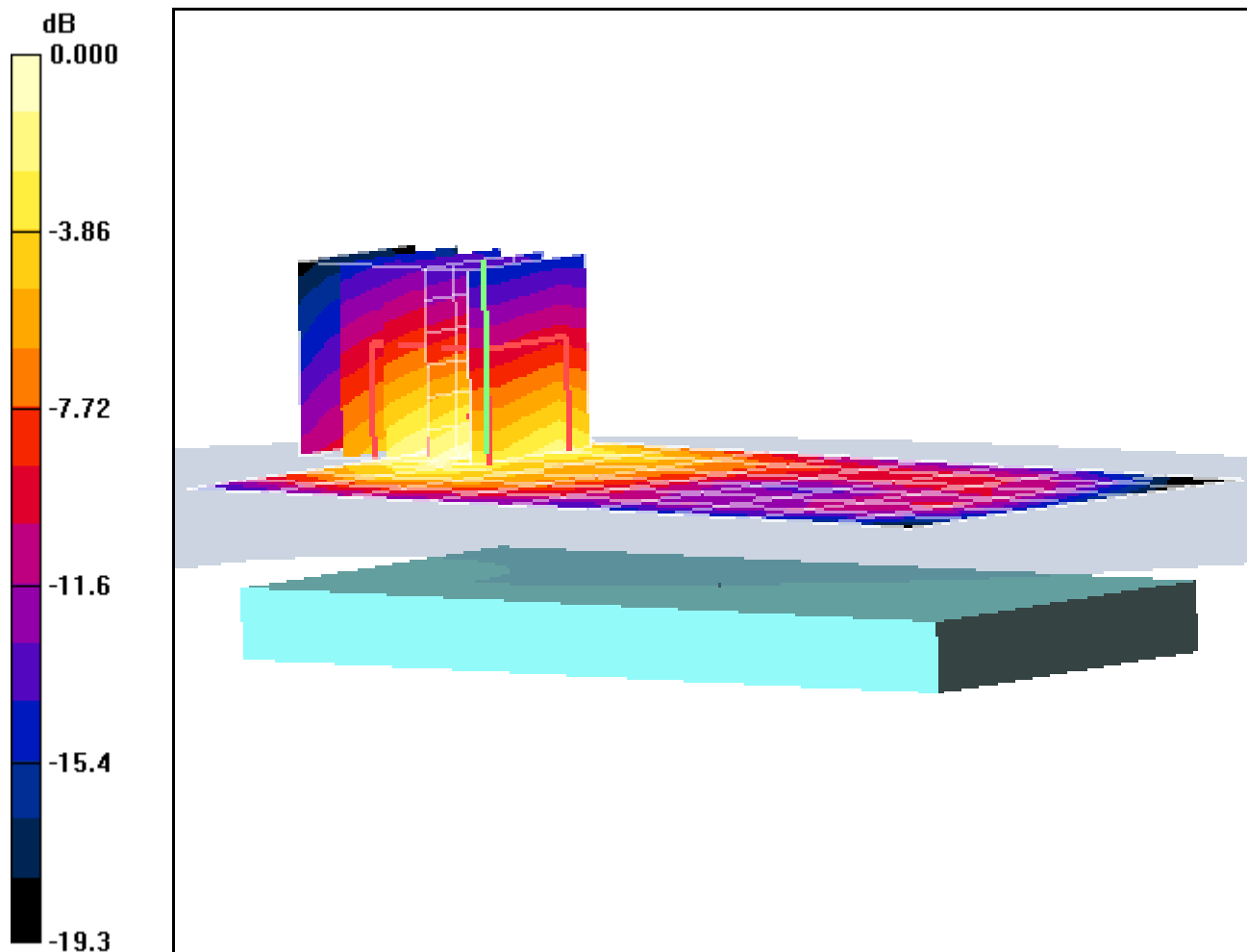

0 dB = 0.744mW/g

PCTEST ENGINEERING LABORATORY, INC.

**DUT: A3LSWDSC02C; Type: 850/1900 GSM/GPRS/EDGE Phone with Bluetooth and WLAN;
Serial: FI-095-A**

Communication System: GSM1900 GPRS; 2 Tx slots; Frequency: 1880 MHz; Duty Cycle: 1:4.15
Medium: 1900 Body Medium parameters used:
 $f = 1880 \text{ MHz}; \sigma = 1.53 \text{ mho/m}; \epsilon_r = 52.6; \rho = 1000 \text{ kg/m}^3$
Phantom section: Flat Section; Space: 1.0 cm

Test Date: 05-03-2011; Ambient Temp: 23.3°C; Tissue Temp: 22.2°C

Probe: EX3DV4 - SN3561; ConvF(6.59, 6.59, 6.59); Calibrated: 8/19/2010
Sensor-Surface: 4mm (Mechanical Surface Detection)
Electronics: DAE4 Sn649; Calibrated: 2/21/2011
Phantom: SAM Sub; Type: SAM 4.0; Serial: TP-1357

Measurement SW: DASY4, V4.7 Build 80; Postprocessing SW: SEMCAD, V1.8 Build 186

Mode: GPRS 1900, Body SAR, Back side, Mid.ch, 2 Tx Slots

Area Scan (7x10x1): Measurement grid: dx=15mm, dy=15mm

Zoom Scan (5x5x7)/Cube 0: Measurement grid: dx=8mm, dy=8mm, dz=5mm

Reference Value = 19.2 V/m

Peak SAR (extrapolated) = 1.22 W/kg

SAR(1 g) = 0.690 mW/g; SAR(10 g) = 0.364 mW/g

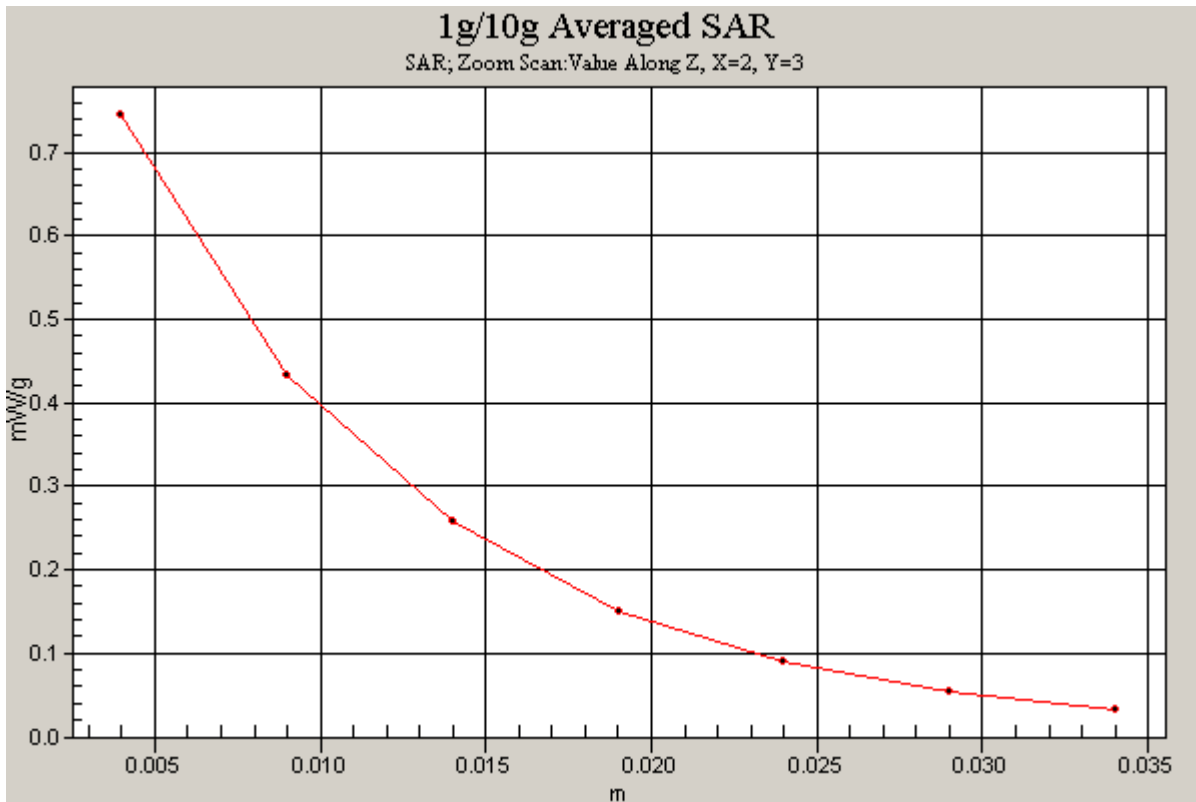

PCTEST ENGINEERING LABORATORY, INC.

**DUT: A3LSWDSC02C; Type: 850/1900 GSM/GPRS/EDGE Phone with Bluetooth and WLAN;
Serial: FI-095-A**

Communication System: GSM1900 GPRS; 2 Tx slots; Frequency: 1880 MHz; Duty Cycle: 1:4.15
Medium: 1900 Body Medium parameters used:
 $f = 1880 \text{ MHz}$; $\sigma = 1.53 \text{ mho/m}$; $\epsilon_r = 52.6$; $\rho = 1000 \text{ kg/m}^3$
Phantom section: Flat Section; Space: 1.0 cm

Test Date: 05-03-2011; Ambient Temp: 23.3°C; Tissue Temp: 22.2°C

Probe: EX3DV4 - SN3561; ConvF(6.59, 6.59, 6.59); Calibrated: 8/19/2010
Sensor-Surface: 4mm (Mechanical Surface Detection)
Electronics: DAE4 Sn649; Calibrated: 2/21/2011
Phantom: SAM Sub; Type: SAM 4.0; Serial: TP-1357

Measurement SW: DASY4, V4.7 Build 80; Postprocessing SW: SEMCAD, V1.8 Build 186

Mode: GPRS 1900, Body SAR, Front side, Mid.ch, 2 Tx Slots

Area Scan (7x10x1): Measurement grid: dx=15mm, dy=15mm

Zoom Scan (5x5x7)/Cube 0: Measurement grid: dx=8mm, dy=8mm, dz=5mm

Reference Value = 12.7 V/m

Peak SAR (extrapolated) = 0.375 W/kg

SAR(1 g) = 0.235 mW/g; SAR(10 g) = 0.143 mW/g

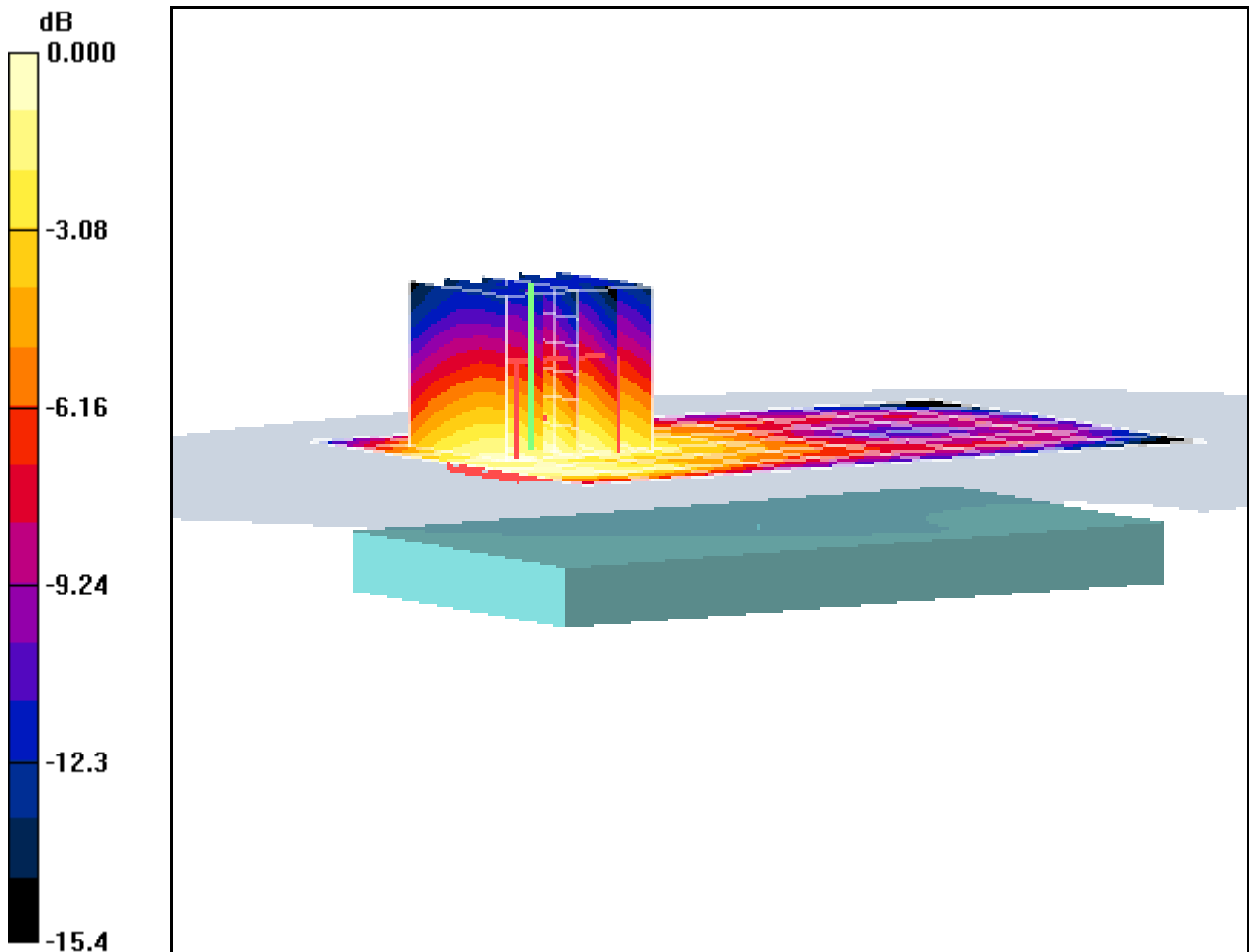

0 dB = 0.255mW/g

PCTEST ENGINEERING LABORATORY, INC.

**DUT: A3LSWDSC02C; Type: 850/1900 GSM/GPRS/EDGE Phone with Bluetooth and WLAN;
Serial: FI-095-A**

Communication System: GSM1900 GPRS; 2 Tx slots; Frequency: 1880 MHz; Duty Cycle: 1:4.15

Medium: 1900 Body Medium parameters used:

$$f = 1880 \text{ MHz}; \sigma = 1.53 \text{ mho/m}; \epsilon_r = 52.6; \rho = 1000 \text{ kg/m}^3$$

Phantom section: Flat Section; Space: 1.0 cm

Test Date: 05-03-2011; Ambient Temp: 23.3°C; Tissue Temp: 22.2°C

Probe: EX3DV4 - SN3561; ConvF(6.59, 6.59, 6.59); Calibrated: 8/19/2010

Sensor-Surface: 4mm (Mechanical Surface Detection)

Electronics: DAE4 Sn649; Calibrated: 2/21/2011

Phantom: SAM Sub; Type: SAM 4.0; Serial: TP-1357

Measurement SW: DASY4, V4.7 Build 80; Postprocessing SW: SEMCAD, V1.8 Build 186

Mode: GPRS 1900, Body SAR, Bottom Edge, Mid.ch, 2 Tx Slots

Area Scan (5x7x1): Measurement grid: dx=15mm, dy=15mm

Zoom Scan (5x5x7)/Cube 0: Measurement grid: dx=8mm, dy=8mm, dz=5mm

Reference Value = 16.2 V/m

Peak SAR (extrapolated) = 0.890 W/kg

SAR(1 g) = 0.510 mW/g; SAR(10 g) = 0.276 mW/g

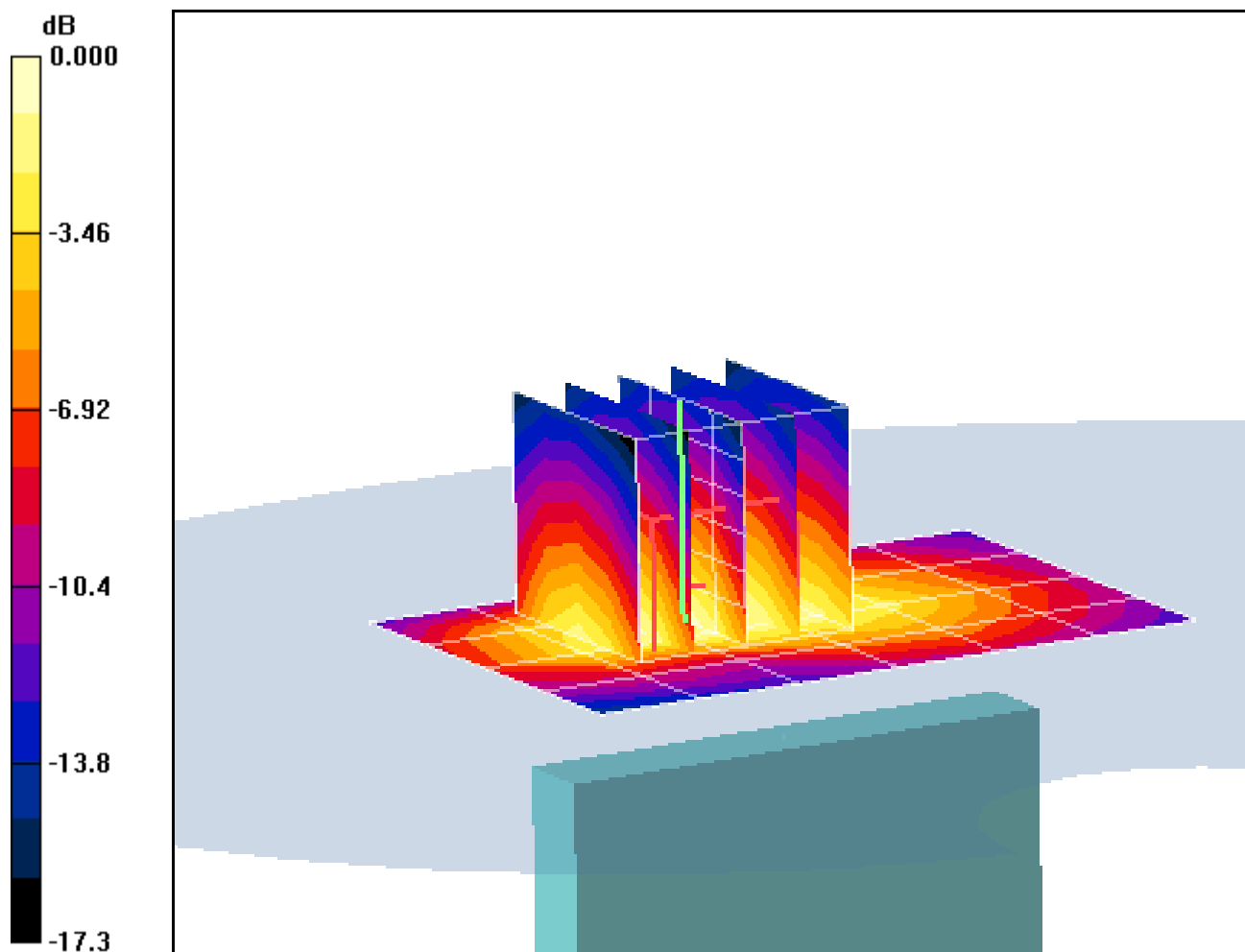

0 dB = 0.575mW/g

PCTEST ENGINEERING LABORATORY, INC.

**DUT: A3LSWDSC02C; Type: 850/1900 GSM/GPRS/EDGE Phone with Bluetooth and WLAN;
Serial: FI-095-A**

Communication System: GSM1900 GPRS; 2 Tx slots; Frequency: 1880 MHz; Duty Cycle: 1:4.15

Medium: 1900 Body Medium parameters used:

$$f = 1880 \text{ MHz}; \sigma = 1.53 \text{ mho/m}; \epsilon_r = 52.6; \rho = 1000 \text{ kg/m}^3$$

Phantom section: Flat Section; Space: 1.0 cm

Test Date: 05-03-2011; Ambient Temp: 23.3°C; Tissue Temp: 22.2°C

Probe: EX3DV4 - SN3561; ConvF(6.59, 6.59, 6.59); Calibrated: 8/19/2010

Sensor-Surface: 4mm (Mechanical Surface Detection)

Electronics: DAE4 Sn649; Calibrated: 2/21/2011

Phantom: SAM Sub; Type: SAM 4.0; Serial: TP-1357

Measurement SW: DASY4, V4.7 Build 80; Postprocessing SW: SEMCAD, V1.8 Build 186

Mode: GPRS 1900, Body SAR, Right Edge, Mid.ch, 2 Tx Slots

Area Scan (5x13x1): Measurement grid: dx=15mm, dy=15mm

Zoom Scan (5x5x7)/Cube 0: Measurement grid: dx=8mm, dy=8mm, dz=5mm

Reference Value = 11.5 V/m

Peak SAR (extrapolated) = 0.378 W/kg

SAR(1 g) = 0.215 mW/g; SAR(10 g) = 0.119 mW/g

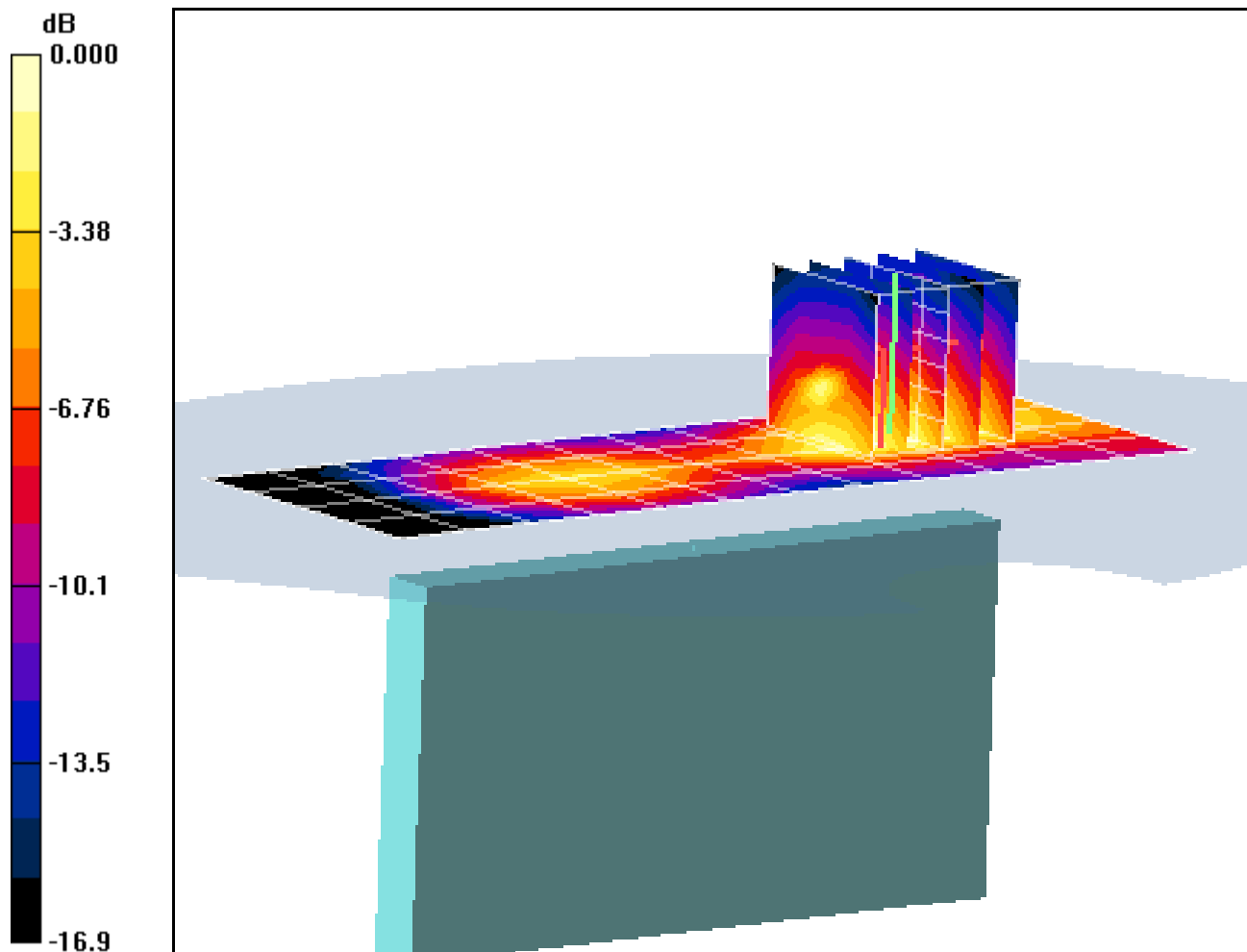

0 dB = 0.234mW/g

PCTEST ENGINEERING LABORATORY, INC.

**DUT: A3LSWDSC02C; Type: 850/1900 GSM/GPRS/EDGE Phone with Bluetooth and WLAN
Serial: FI-095-A**

Communication System: IEEE 802.11b; Frequency: 2462 MHz; Duty Cycle: 1:1
Medium: 2450 Body; Medium parameters used (interpolated):
 $f = 2462 \text{ MHz}$; $\sigma = 2.03 \text{ mho/m}$; $\epsilon_r = 50.1$; $\rho = 1000 \text{ kg/m}^3$
Phantom section: Flat Section; Space: 1.0 cm

Test Date: 05-02-2011; Ambient Temp: 24.3°C; Tissue Temp: 22.4° C

Probe: EX3DV4 - SN3550; ConvF(6.25, 6.25, 6.25); Calibrated: 2/14/2011
Sensor-Surface: 3mm (Mechanical Surface Detection)
Electronics: DAE4 Sn859; Calibrated: 7/8/2010
Phantom: SAM Main; Type: SAM 4.0; Serial: TP-1114
Measurement SW: DASY4, V4.7 Build 80; Postprocessing SW: SEMCAD, V1.8 Build 186

Mode: IEEE 802.11b, Body SAR, Ch.11, 1Mbps, Back Side

Area Scan (7x11x1): Measurement grid: dx=15mm, dy=15mm
Zoom Scan (5x5x7)/Cube 0: Measurement grid: dx=8mm, dy=8mm, dz=5mm
Reference Value = 7.68 V/m
Peak SAR (extrapolated) = 0.238 W/kg
SAR(1 g) = 0.120 mW/g; SAR(10 g) = 0.063 mW/g

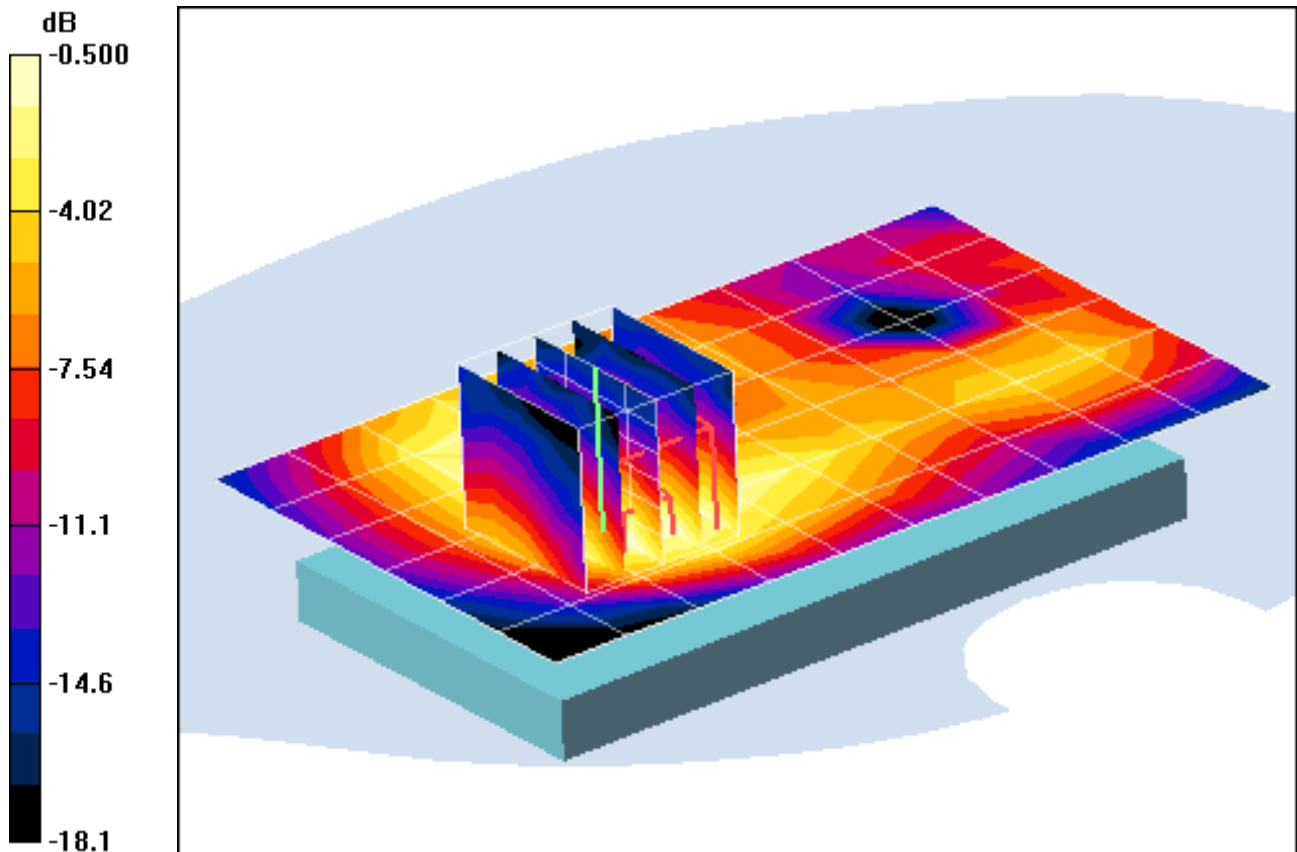

0 dB = 0.146mW/g

PCTEST ENGINEERING LABORATORY, INC.

**DUT: A3LSWDSC02C; Type: 850/1900 GSM/GPRS/EDGE Phone with Bluetooth and WLAN
Serial: FI-095-A**

Communication System: IEEE 802.11b; Frequency: 2462 MHz; Duty Cycle: 1:1
Medium: 2450 Body; Medium parameters used (interpolated):
 $f = 2462 \text{ MHz}$; $\sigma = 2.03 \text{ mho/m}$; $\epsilon_r = 50.1$; $\rho = 1000 \text{ kg/m}^3$
Phantom section: Flat Section; Space: 1.0 cm

Test Date: 05-02-2011; Ambient Temp: 24.3°C; Tissue Temp: 22.4° C

Probe: EX3DV4 - SN3550; ConvF(6.25, 6.25, 6.25); Calibrated: 2/14/2011
Sensor-Surface: 3mm (Mechanical Surface Detection)
Electronics: DAE4 Sn859; Calibrated: 7/8/2010
Phantom: SAM Main; Type: SAM 4.0; Serial: TP-1114
Measurement SW: DASY4, V4.7 Build 80; Postprocessing SW: SEMCAD, V1.8 Build 186

Mode: IEEE 802.11b, Body SAR, Ch.11, 1Mbps, Back Side

Area Scan (7x11x1): Measurement grid: dx=15mm, dy=15mm
Zoom Scan (5x5x7)/Cube 0: Measurement grid: dx=8mm, dy=8mm, dz=5mm
Reference Value = 7.68 V/m
Peak SAR (extrapolated) = 0.238 W/kg
SAR(1 g) = 0.120 mW/g; SAR(10 g) = 0.063 mW/g

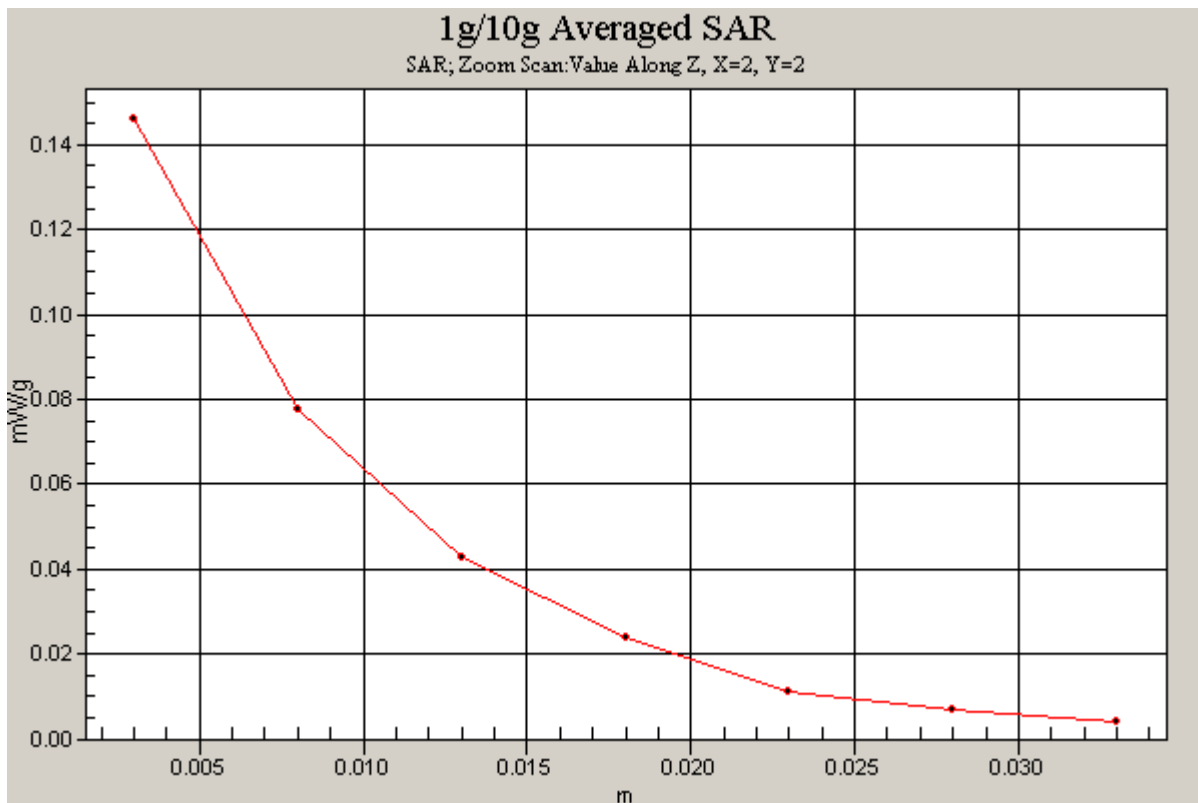

PCTEST ENGINEERING LABORATORY, INC.

**DUT: A3LSWDSC02C; Type: 850/1900 GSM/GPRS/EDGE Phone with Bluetooth and WLAN
Serial: FI-095-A**

Communication System: IEEE 802.11b; Frequency: 2462 MHz; Duty Cycle: 1:1
Medium: 2450 Body; Medium parameters used (interpolated):
 $f = 2462 \text{ MHz}$; $\sigma = 2.03 \text{ mho/m}$; $\epsilon_r = 50.1$; $\rho = 1000 \text{ kg/m}^3$
Phantom section: Flat Section; Space: 1.0 cm

Test Date: 05-02-2011; Ambient Temp: 24.3°C; Tissue Temp: 22.4° C

Probe: EX3DV4 - SN3550; ConvF(6.25, 6.25, 6.25); Calibrated: 2/14/2011
Sensor-Surface: 3mm (Mechanical Surface Detection)
Electronics: DAE4 Sn859; Calibrated: 7/8/2010
Phantom: SAM Main; Type: SAM 4.0; Serial: TP-1114
Measurement SW: DASY4, V4.7 Build 80; Postprocessing SW: SEMCAD, V1.8 Build 186

Mode: IEEE 802.11b, Body SAR, Ch.11, 1Mbps, Front Side

Area Scan (7x11x1): Measurement grid: dx=15mm, dy=15mm
Zoom Scan (5x5x7)/Cube 0: Measurement grid: dx=8mm, dy=8mm, dz=5mm
Reference Value = 6.34 V/m
Peak SAR (extrapolated) = 0.147 W/kg
SAR(1 g) = 0.078 mW/g; SAR(10 g) = 0.042 mW/g

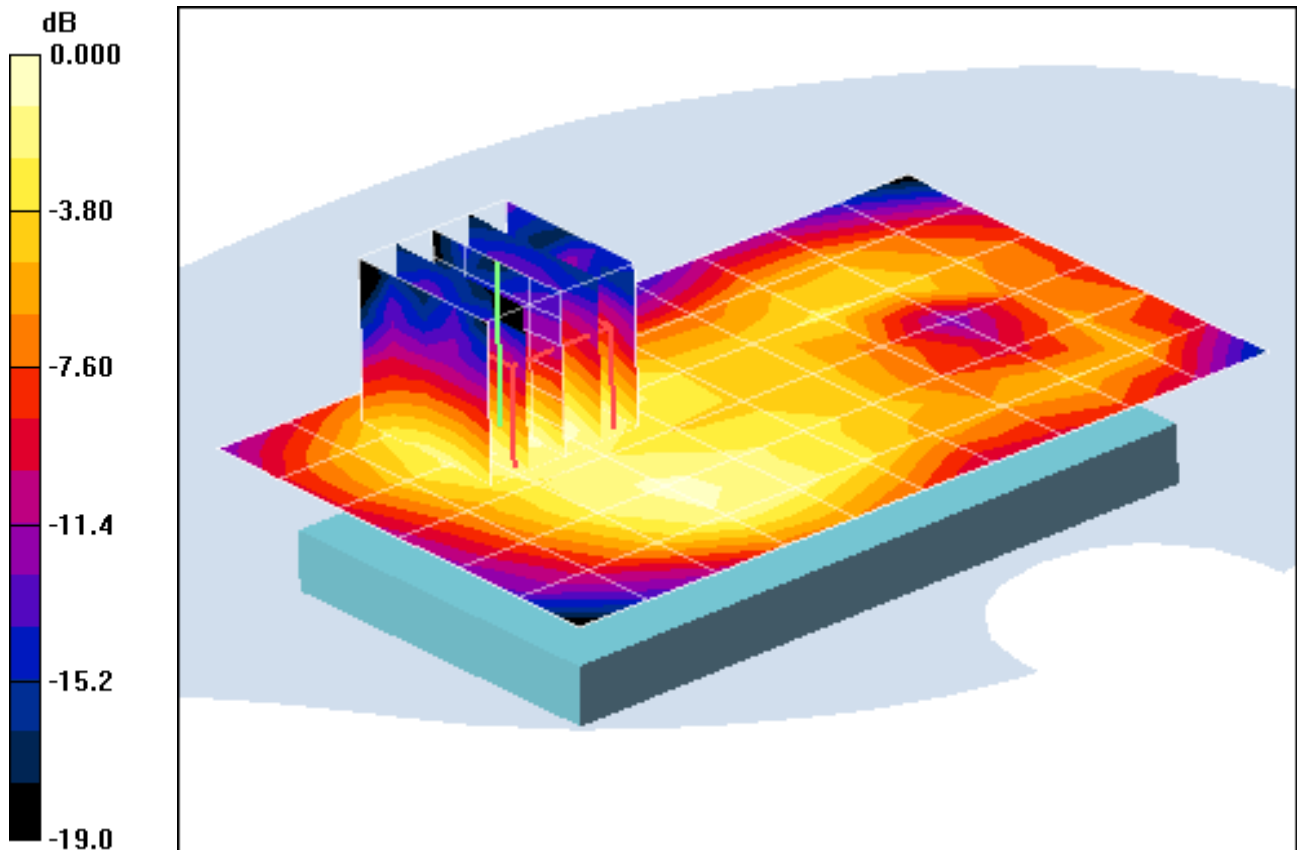

0 dB = 0.098mW/g

PCTEST ENGINEERING LABORATORY, INC.

**DUT: A3LSWDSC02C; Type: 850/1900 GSM/GPRS/EDGE Phone with Bluetooth and WLAN
Serial: FI-095-A**

Communication System: IEEE 802.11b; Frequency: 2462 MHz; Duty Cycle: 1:1
Medium: 2450 Body; Medium parameters used (interpolated):
 $f = 2462 \text{ MHz}$; $\sigma = 2.03 \text{ mho/m}$; $\epsilon_r = 50.1$; $\rho = 1000 \text{ kg/m}^3$
Phantom section: Flat Section; Space: 1.0 cm

Test Date: 05-02-2011; Ambient Temp: 24.3°C; Tissue Temp: 22.4° C

Probe: EX3DV4 - SN3550; ConvF(6.25, 6.25, 6.25); Calibrated: 2/14/2011
Sensor-Surface: 3mm (Mechanical Surface Detection)
Electronics: DAE4 Sn859; Calibrated: 7/8/2010
Phantom: SAM Main; Type: SAM 4.0; Serial: TP-1114
Measurement SW: DASY4, V4.7 Build 80; Postprocessing SW: SEMCAD, V1.8 Build 186

Mode: IEEE 802.11b, Body SAR, Ch.11, 1Mbps, Bottom Edge

Area Scan (5x7x1): Measurement grid: dx=15mm, dy=15mm
Zoom Scan (5x5x7)/Cube 0: Measurement grid: dx=8mm, dy=8mm, dz=5mm
Reference Value = 7.86 V/m
Peak SAR (extrapolated) = 0.222 W/kg
SAR(1 g) = 0.119 mW/g; SAR(10 g) = 0.065 mW/g

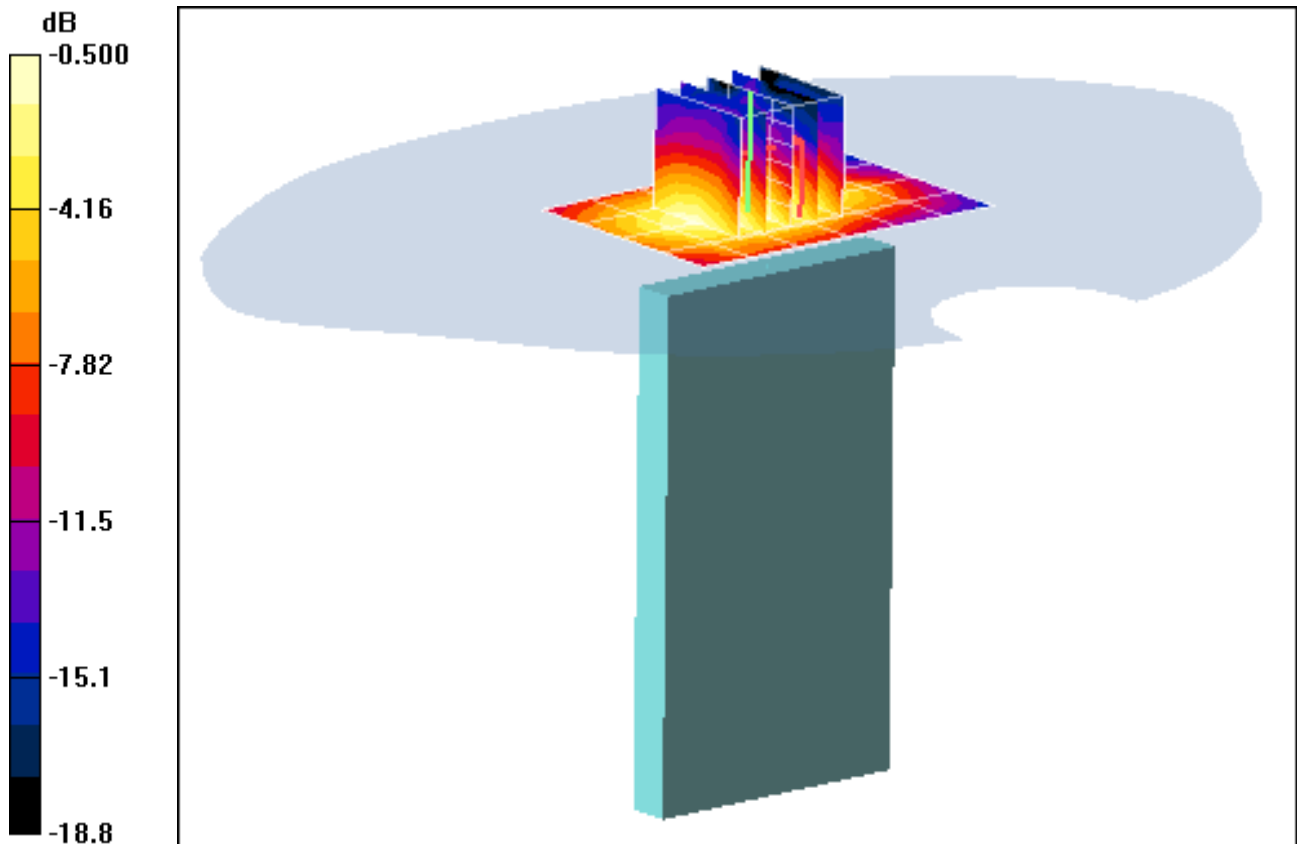

0 dB = 0.147mW/g

PCTEST ENGINEERING LABORATORY, INC.

**DUT: A3LSWDSC02C; Type: 850/1900 GSM/GPRS/EDGE Phone with Bluetooth and WLAN
Serial: FI-095-A**

Communication System: IEEE 802.11b; Frequency: 2462 MHz; Duty Cycle: 1:1
Medium: 2450 Body; Medium parameters used (interpolated):
 $f = 2462 \text{ MHz}$; $\sigma = 2.03 \text{ mho/m}$; $\epsilon_r = 50.1$; $\rho = 1000 \text{ kg/m}^3$
Phantom section: Flat Section; Space: 1.0 cm

Test Date: 05-02-2011; Ambient Temp: 24.3°C; Tissue Temp: 22.4° C

Probe: EX3DV4 - SN3550; ConvF(6.25, 6.25, 6.25); Calibrated: 2/14/2011
Sensor-Surface: 3mm (Mechanical Surface Detection)
Electronics: DAE4 Sn859; Calibrated: 7/8/2010
Phantom: SAM Main; Type: SAM 4.0; Serial: TP-1114
Measurement SW: DASY4, V4.7 Build 80; Postprocessing SW: SEMCAD, V1.8 Build 186

Mode: IEEE 802.11b, Body SAR, Ch.11, 1Mbps, Left Edge

Area Scan (5x11x1): Measurement grid: dx=15mm, dy=15mm

Zoom Scan (5x5x7)/Cube 0: Measurement grid: dx=8mm, dy=8mm, dz=5mm

Reference Value = 6.83 V/m

Peak SAR (extrapolated) = 0.161 W/kg

SAR(1 g) = 0.085 mW/g; SAR(10 g) = 0.045 mW/g

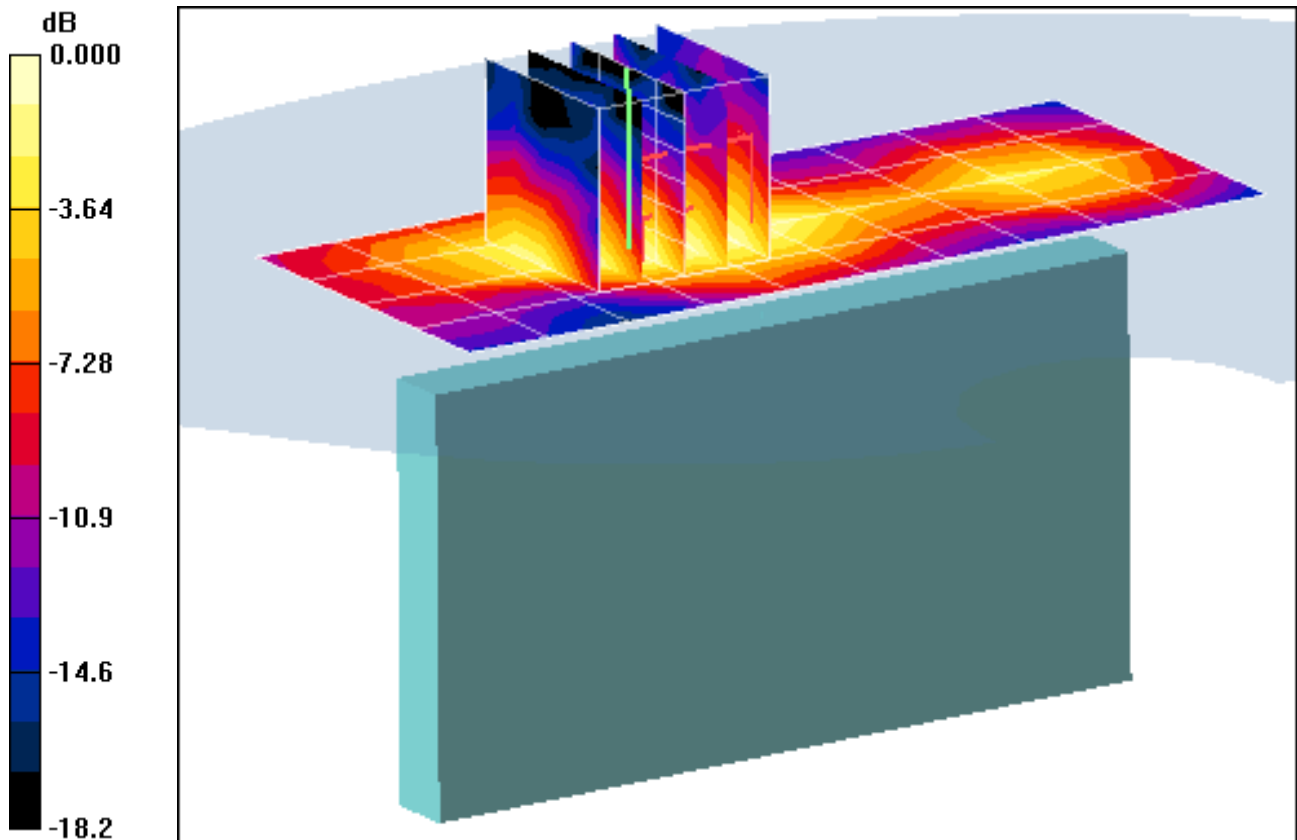

0 dB = 0.107mW/g

PCTEST ENGINEERING LABORATORY, INC.

**DUT: A3LSWDSC02C; Type: 850/1900 GSM/GPRS/EDGE Phone with Bluetooth and WLAN
Serial: FI-095-B**

Communication System: IEEE 802.11a 5.2-5.8 GHz Band; Frequency: 5180 MHz; Duty Cycle: 1:1
Medium: 5 GHz Body; Medium parameters used (interpolated):
 $f = 5180 \text{ MHz}$; $\sigma = 5.26 \text{ mho/m}$; $\epsilon_r = 49.1$; $\rho = 1000 \text{ kg/m}^3$
Phantom section: Flat Section; Space: 1.0 cm

Test Date: 05-04-2011; Ambient Temp: 24.3°C ; Tissue Temp: 22.6°C

Probe: EX3DV4 - SN3550; ConvF(3.58, 3.58, 3.58); Calibrated: 2/14/2011
Sensor-Surface: 2mm (Mechanical Surface Detection)
Electronics: DAE4 Sn859; Calibrated: 7/8/2010
Phantom: SAM Main; Type: SAM 4.0; Serial: TP-1114
Measurement SW: DASY4, V4.7 Build 80; Postprocessing SW: SEMCAD, V1.8 Build 186

Mode: IEEE 802.11a 5.2 GHz, Body SAR, Ch.36, 6Mbps, Back Side

Area Scan (10x16x1): Measurement grid: dx=10mm, dy=10mm
Zoom Scan (7x7x11)/Cube 0: Measurement grid: dx=4mm, dy=4mm, dz=2mm
Reference Value = 1.82 V/m
Peak SAR (extrapolated) = 0.237 W/kg
SAR(1 g) = 0.016 mW/g; SAR(10 g) = 0.00393 mW/g

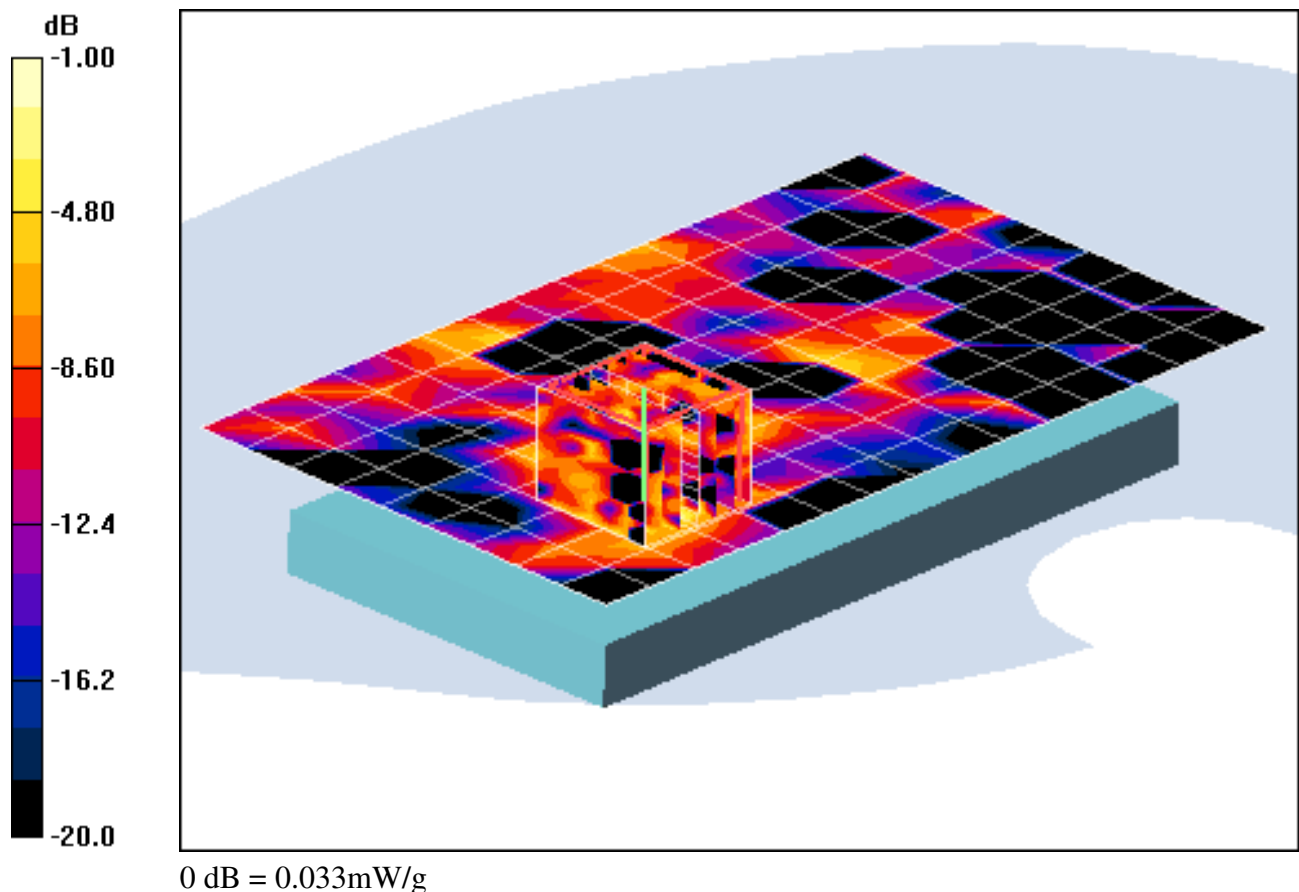

PCTEST ENGINEERING LABORATORY, INC.

**DUT: A3LSWDSC02C; Type: 850/1900 GSM/GPRS/EDGE Phone with Bluetooth and WLAN
Serial: FI-095-B**

Communication System: IEEE 802.11a 5.2-5.8 GHz Band; Frequency: 5260 MHz; Duty Cycle: 1:1
Medium: 5 GHz Body; Medium parameters used (interpolated):
 $f = 5260 \text{ MHz}$; $\sigma = 5.39 \text{ mho/m}$; $\epsilon_r = 49$; $\rho = 1000 \text{ kg/m}^3$
Phantom section: Flat Section; Space: 1.0 cm

Test Date: 05-04-2011; Ambient Temp: 24.3°C ; Tissue Temp: 22.6°C

Probe: EX3DV4 - SN3550; ConvF(3.31, 3.31, 3.31); Calibrated: 2/14/2011
Sensor-Surface: 2mm (Mechanical Surface Detection)
Electronics: DAE4 Sn859; Calibrated: 7/8/2010
Phantom: SAM Main; Type: SAM 4.0; Serial: TP-1114
Measurement SW: DASY4, V4.7 Build 80; Postprocessing SW: SEMCAD, V1.8 Build 186

Mode: IEEE 802.11a 5.3 GHz, Body SAR, Ch.52, 6Mbps, Back Side

Area Scan (10x16x1): Measurement grid: dx=10mm, dy=10mm
Zoom Scan (7x7x11)/Cube 0: Measurement grid: dx=4mm, dy=4mm, dz=2mm
Reference Value = 2.17 V/m
Peak SAR (extrapolated) = 0.212 W/kg
SAR(1 g) = 0.021 mW/g; SAR(10 g) = 0.00298 mW/g

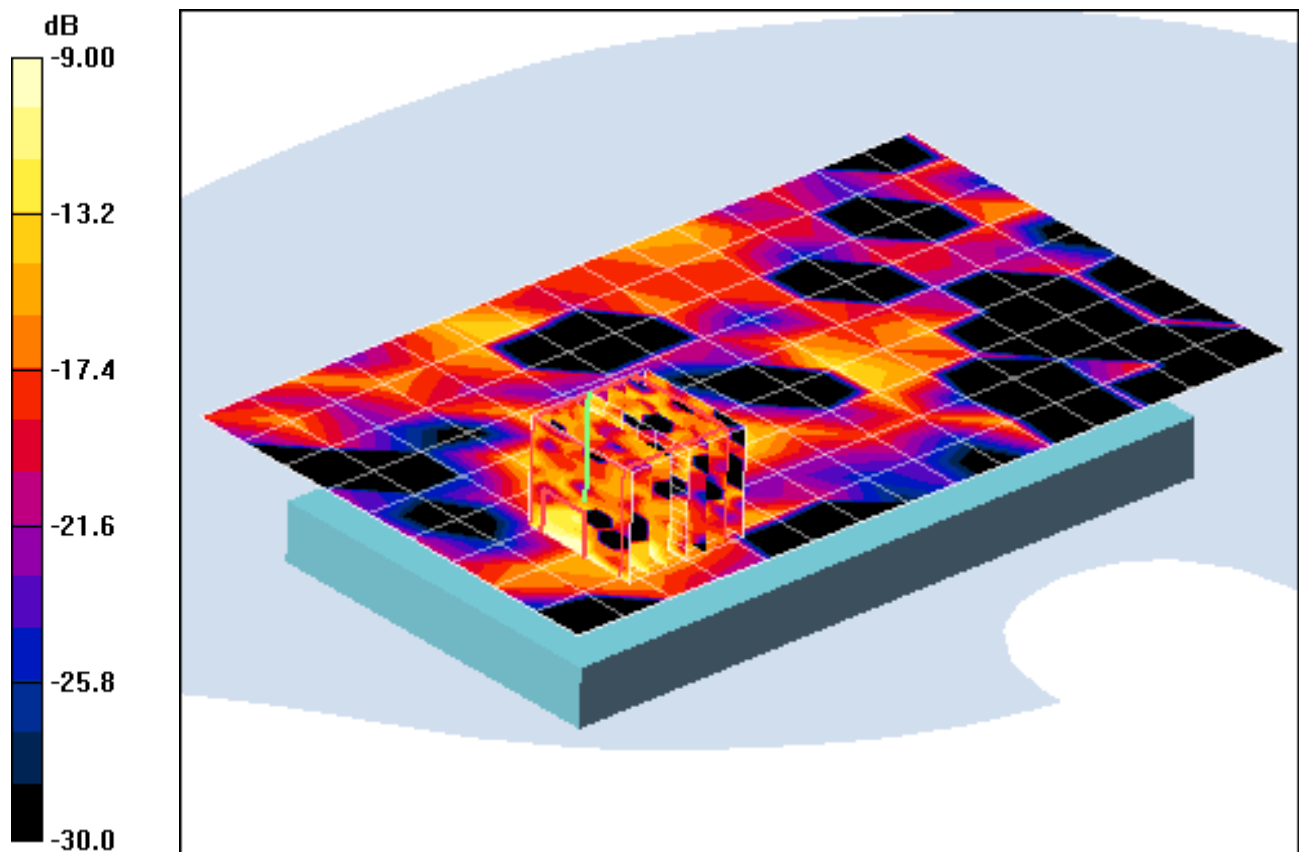

0 dB = 0.212mW/g

PCTEST ENGINEERING LABORATORY, INC.

**DUT: A3LSWDSC02C; Type: 850/1900 GSM/GPRS/EDGE Phone with Bluetooth and WLAN
Serial: FI-095-B**

Communication System: IEEE 802.11a 5.2-5.8 GHz Band; Frequency: 5700 MHz; Duty Cycle: 1:1
Medium: 5 GHz Body; Medium parameters used (interpolated):
 $f = 5700 \text{ MHz}$; $\sigma = 6.04 \text{ mho/m}$; $\epsilon_r = 48$; $\rho = 1000 \text{ kg/m}^3$
Phantom section: Flat Section; Space: 1.0 cm

Test Date: 05-04-2011; Ambient Temp: 24.5°C ; Tissue Temp: 22.7°C

Probe: EX3DV4 - SN3550; ConvF(3.19, 3.19, 3.19); Calibrated: 2/14/2011
Sensor-Surface: 2mm (Mechanical Surface Detection)
Electronics: DAE4 Sn859; Calibrated: 7/8/2010
Phantom: SAM Main; Type: SAM 4.0; Serial: TP-1114
Measurement SW: DASY4, V4.7 Build 80; Postprocessing SW: SEMCAD, V1.8 Build 186

Mode: IEEE 802.11a 5.5 GHz, Body SAR, Ch.140, 6Mbps, Back Side

Area Scan (10x16x1): Measurement grid: dx=10mm, dy=10mm
Zoom Scan (7x7x11)/Cube 0: Measurement grid: dx=4mm, dy=4mm, dz=2mm
Reference Value = 3.82 V/m
Peak SAR (extrapolated) = 0.568 W/kg
SAR(1 g) = 0.071 mW/g; SAR(10 g) = 0.025 mW/g

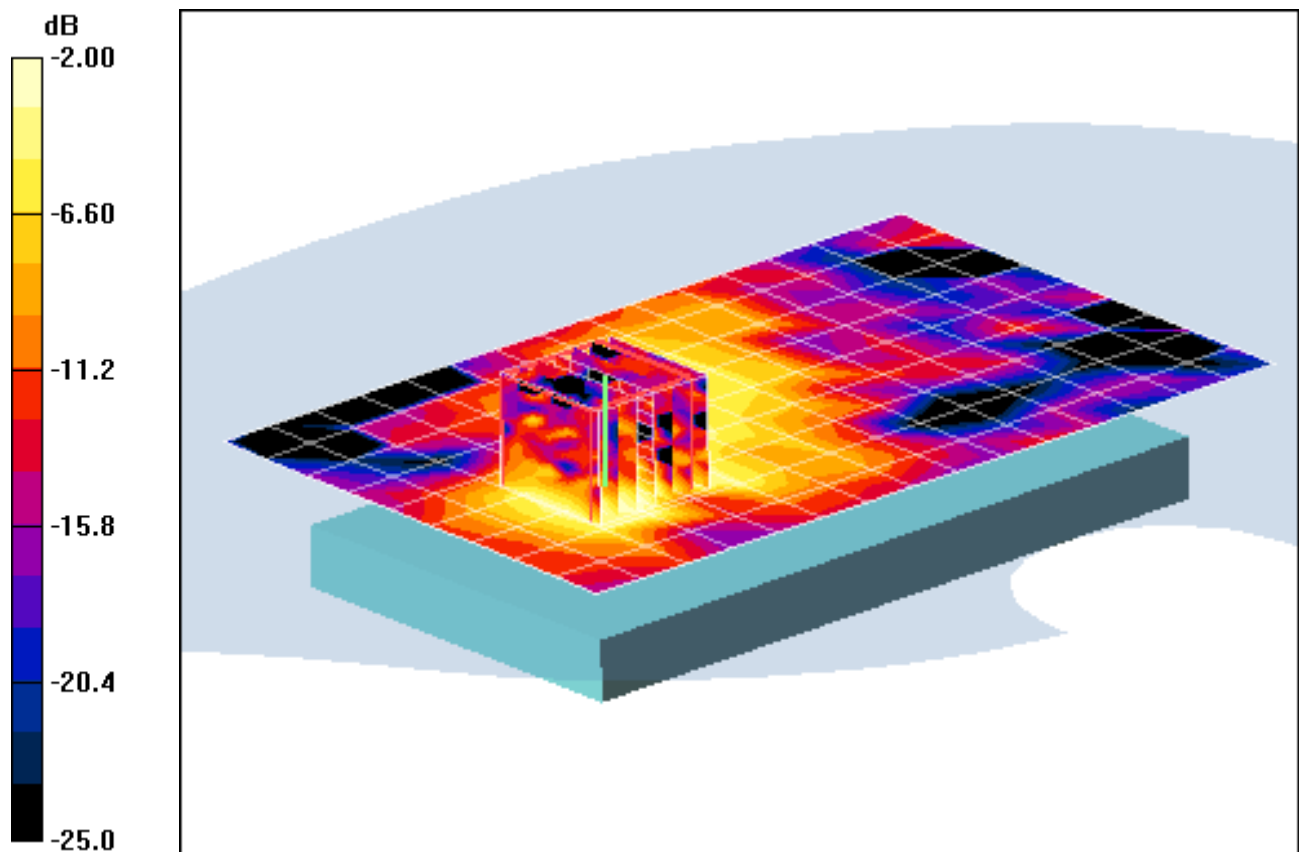

0 dB = 0.174mW/g

PCTEST ENGINEERING LABORATORY, INC.

DUT: Dipole 5500 MHz; Type: D5GHzV2; Serial: 1057

Communication System: CW; Frequency: 5500 MHz; Duty Cycle: 1:1

Medium: 5 GHz Body; Medium parameters used (interpolated):

$f = 5500 \text{ MHz}$; $\sigma = 5.75 \text{ mho/m}$; $\epsilon_r = 48.4$; $\rho = 1000 \text{ kg/m}^3$

Phantom section: Flat Section; Space: 1.0 cm

Test Date: 05-04-2011; Ambient Temp: 24.5°C ; Tissue Temp: 22.7°C

Probe: EX3DV4 - SN3550; ConvF(3.21, 3.21, 3.21); Calibrated: 2/14/2011

Sensor-Surface: 2mm (Mechanical Surface Detection)

Electronics: DAE4 Sn859; Calibrated: 7/8/2010

Phantom: SAM Main; Type: SAM 4.0; Serial: TP-1114

Measurement SW: DASY4, V4.7 Build 80; Postprocessing SW: SEMCAD, V1.8 Build 186

5500MHz System Verification

Area Scan (7x9x1): Measurement grid: dx=10mm, dy=10mm

Zoom Scan (7x7x11)/Cube 0: Measurement grid: dx=4mm, dy=4mm, dz=2mm

Input Power = 14 dBm (25 mW)

SAR(1 g) = 2.13 mW/g; SAR(10 g) = 0.567 mW/g

Deviation = 0.83 %

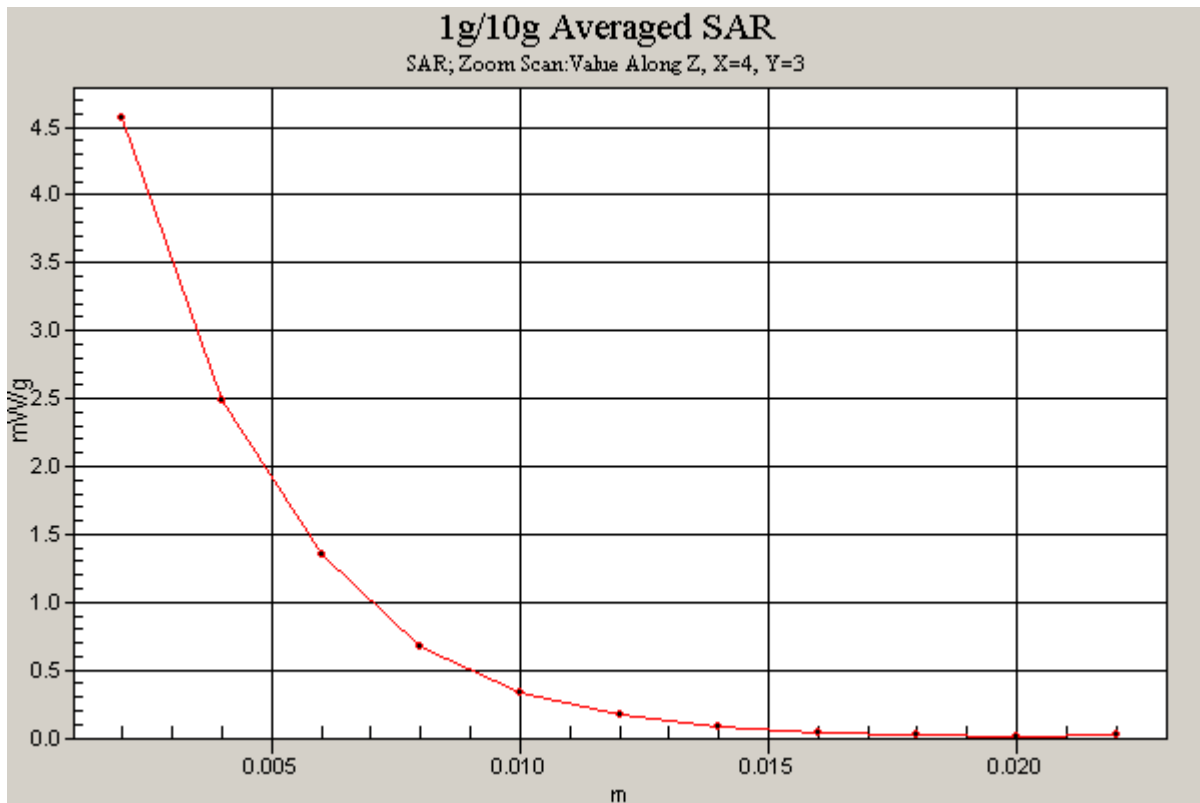

PCTEST ENGINEERING LABORATORY, INC.

**DUT: A3LSWDSC02C; Type: 850/1900 GSM/GPRS/EDGE Phone with Bluetooth and WLAN
Serial: FI-095-B**

Communication System: IEEE 802.11a 5.2-5.8 GHz Band; Frequency: 5745 MHz; Duty Cycle: 1:1
Medium: 5 GHz Body; Medium parameters used (interpolated):
 $f = 5745 \text{ MHz}$; $\sigma = 6.15 \text{ mho/m}$; $\epsilon_r = 47.7$; $\rho = 1000 \text{ kg/m}^3$
Phantom section: Flat Section; Space: 1.0 cm

Test Date: 05-04-2011; Ambient Temp: 24.6°C ; Tissue Temp: 22.9°C

Probe: EX3DV4 - SN3550; ConvF(3.29, 3.29, 3.29); Calibrated: 2/14/2011
Sensor-Surface: 2mm (Mechanical Surface Detection)
Electronics: DAE4 Sn859; Calibrated: 7/8/2010
Phantom: SAM Main; Type: SAM 4.0; Serial: TP-1114
Measurement SW: DASY4, V4.7 Build 80; Postprocessing SW: SEMCAD, V1.8 Build 186

Mode: IEEE 802.11a 5.8 GHz, Body SAR, Ch.149, 6Mbps, Back Side

Area Scan (10x16x1): Measurement grid: dx=10mm, dy=10mm
Zoom Scan (7x7x11)/Cube 0: Measurement grid: dx=4mm, dy=4mm, dz=2mm
Reference Value = 3.88 V/m
Peak SAR (extrapolated) = 0.550 W/kg
SAR(1 g) = 0.068 mW/g; SAR(10 g) = 0.022 mW/g

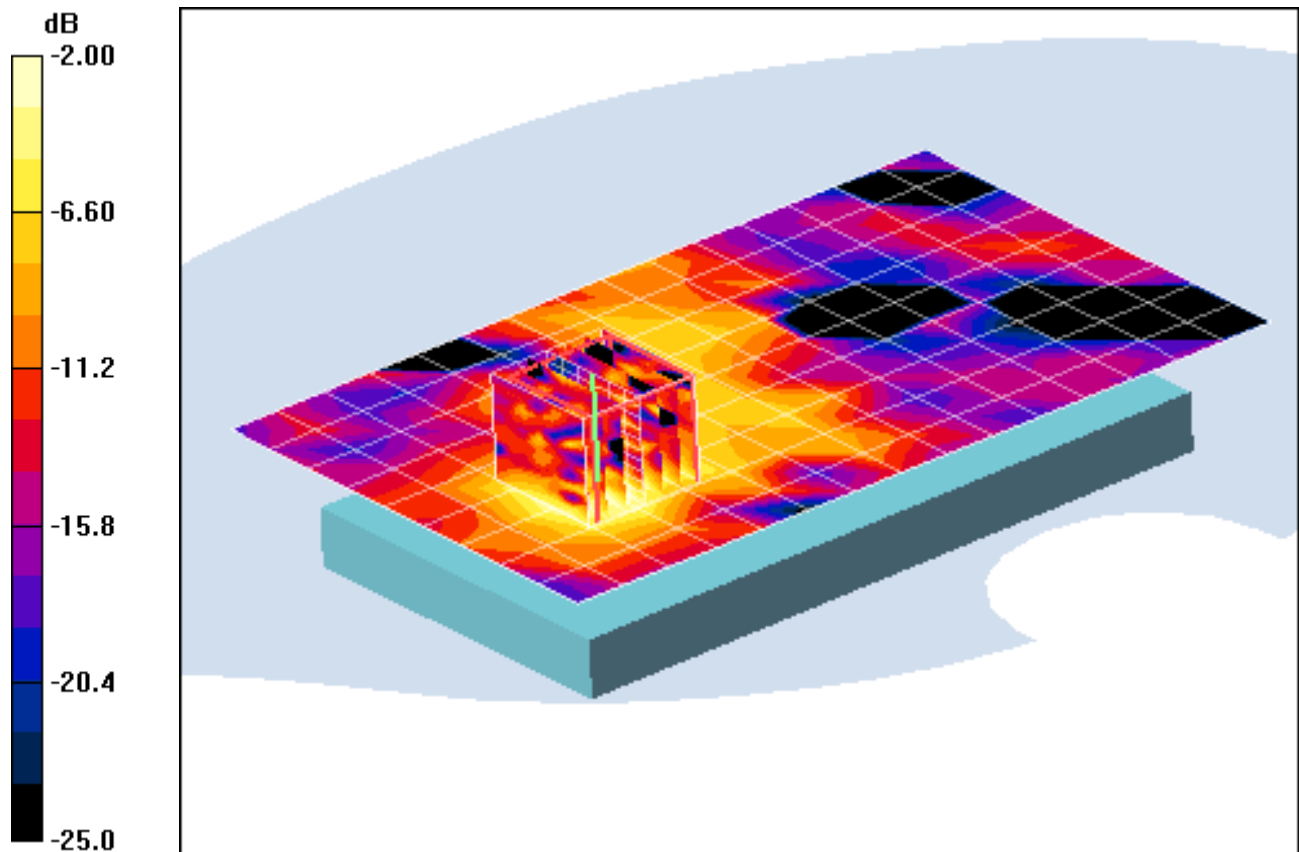

0 dB = 0.169mW/g

APPENDIX B: DIPOLE VALIDATION

PCTEST ENGINEERING LABORATORY, INC.

DUT: Dipole 835 MHz; Type: D835V2; Serial: 4d047

Communication System: CW; Frequency: 835 MHz; Duty Cycle: 1:1

Medium: 835 Head Medium parameters used:

$f = 835 \text{ MHz}$; $\sigma = 0.866 \text{ mho/m}$; $\epsilon_r = 39.99$; $\rho = 1000 \text{ kg/m}^3$

Phantom section: Flat Section; Space: 1.5 cm

Test Date: 05-04-2011; Ambient Temp: 24.0 °C; Tissue Temp: 22.6 °C

Probe: EX3DV4 - SN3561; ConvF(7.96, 7.96, 7.96); Calibrated: 8/19/2010

Sensor-Surface: 4mm (Mechanical Surface Detection)

Electronics: DAE4 Sn649; Calibrated: 2/21/2011

Phantom: SAM Sub; Type: SAM 4.0; Serial: TP-1357

Measurement SW: DASY4, V4.7 Build 80; Postprocessing SW: SEMCAD, V1.8 Build 186

835MHz System Verification

Area Scan (7x13x1): Measurement grid: dx=15mm, dy=15mm

Zoom Scan (5x5x7)/Cube 0: Measurement grid: dx=8mm, dy=8mm, dz=5mm

Input Power = 18.0 dBm (63.0 mW)

SAR(1 g) = 0.571 mW/g; SAR(10 g) = 0.373 mW/g

Deviation = -4.90 %

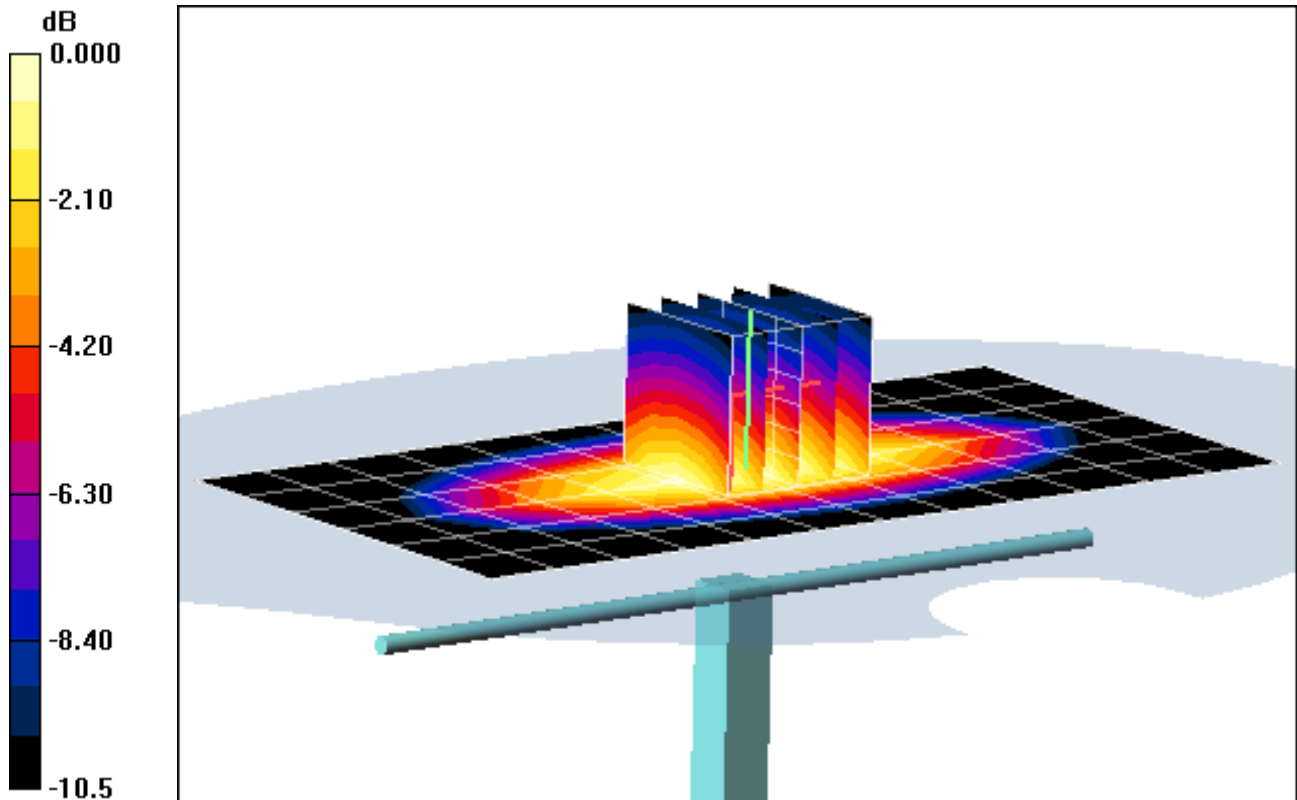

0 dB = 0.615mW/g

PCTEST ENGINEERING LABORATORY, INC.

DUT: Dipole 835 MHz; Type: D835V2; Serial: 4d047

Communication System: CW; Frequency: 835 MHz; Duty Cycle: 1:1

Medium: 835 Body Medium parameters used:

$f = 835 \text{ MHz}$; $\sigma = 0.957 \text{ mho/m}$; $\epsilon_r = 53.15$; $\rho = 1000 \text{ kg/m}^3$

Phantom section: Flat Section; Space: 1.5 cm

Test Date: 05-04-2011; Ambient Temp: 24.2 °C; Tissue Temp: 22.4 °C

Probe: EX3DV4 - SN3561; ConvF(8.09, 8.09, 8.09); Calibrated: 8/19/2010

Sensor-Surface: 4mm (Mechanical Surface Detection)

Electronics: DAE4 Sn649; Calibrated: 2/21/2011

Phantom: SAM Main; Type: SAM 4.0; Serial: TP-1406

Measurement SW: DASY4, V4.7 Build 80; Postprocessing SW: SEMCAD, V1.8 Build 186

835MHz System Verification

Area Scan (7x13x1): Measurement grid: dx=15mm, dy=15mm

Zoom Scan (5x5x7)/Cube 0: Measurement grid: dx=8mm, dy=8mm, dz=5mm

Input Power = 18.0 dBm (63 mW)

SAR(1 g) = 0.617 mW/g; SAR(10 g) = 0.406 mW/g

Deviation = -0.57 %

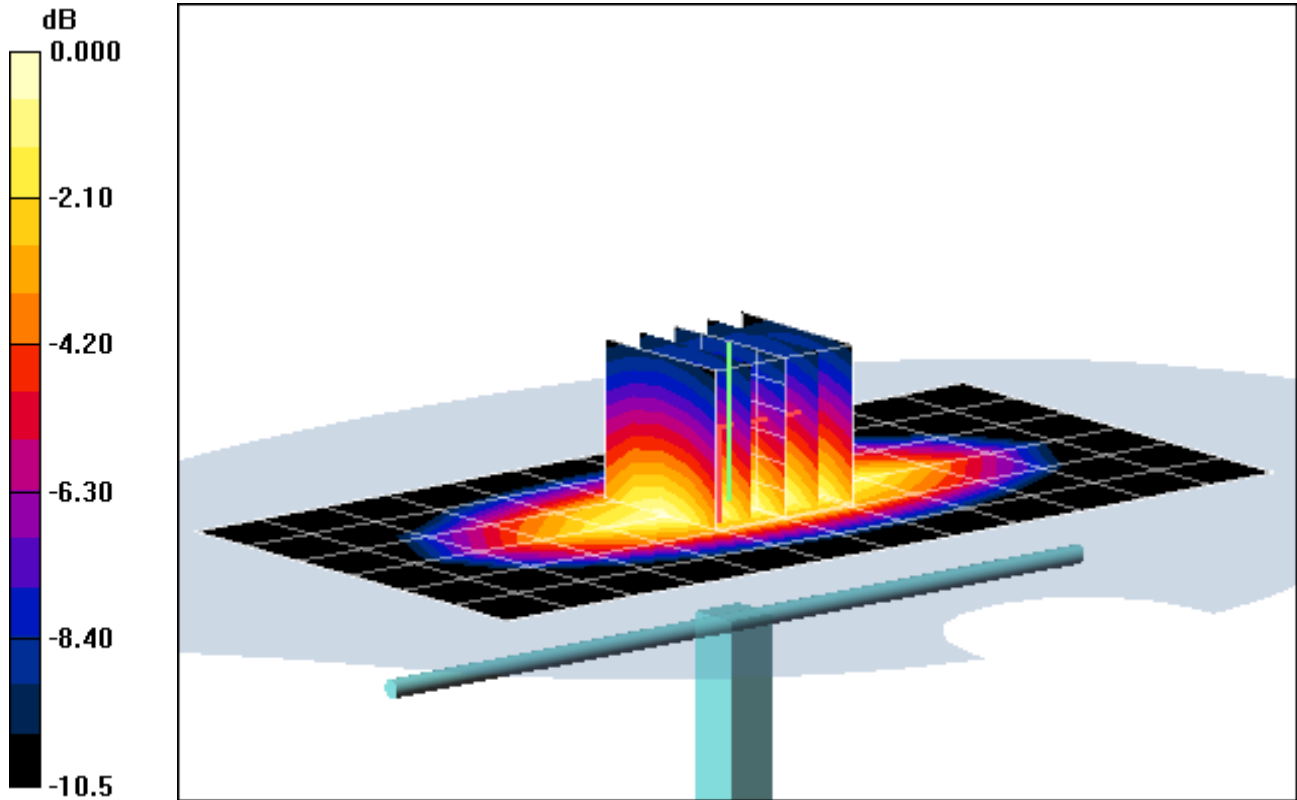

0 dB = 0.666mW/g

PCTEST ENGINEERING LABORATORY, INC.

DUT: SAR Dipole 1900 MHz; Type: D1900V2; Serial: 502

Communication System: CW; Frequency: 1900 MHz; Duty Cycle: 1:1

Medium: 1900 Head; Medium parameters used (interpolated):

$f = 1900 \text{ MHz}$; $\sigma = 1.45 \text{ mho/m}$; $\epsilon_r = 40.44$; $\rho = 1000 \text{ kg/m}^3$

Phantom section: Flat Section; Space: 1.0 cm

Test Date: 05-02-2011; Ambient Temp: 23.9°C; Tissue Temp: 22.8°C

Probe: EX3DV4 - SN3550; ConvF(7.01, 7.01, 7.01); Calibrated: 2/14/2011

Sensor-Surface: 4mm (Mechanical Surface Detection)

Electronics: DAE4 Sn859; Calibrated: 7/8/2010

Phantom: SAM Main; Type: SAM 4.0; Serial: TP-1114

Measurement SW: DASY4, V4.7 Build 80; Postprocessing SW: SEMCAD, V1.8 Build 186

1900MHz System Verification

Area Scan (5x7x1): Measurement grid: dx=15mm, dy=15mm

Zoom Scan (5x5x7)/Cube 0: Measurement grid: dx=8mm, dy=8mm, dz=5mm

Input Power = 16.0 dBm (40 mW)

SAR(1 g) = 1.63 mW/g; SAR(10 g) = 0.825 mW/g

Deviation = 1.37 %

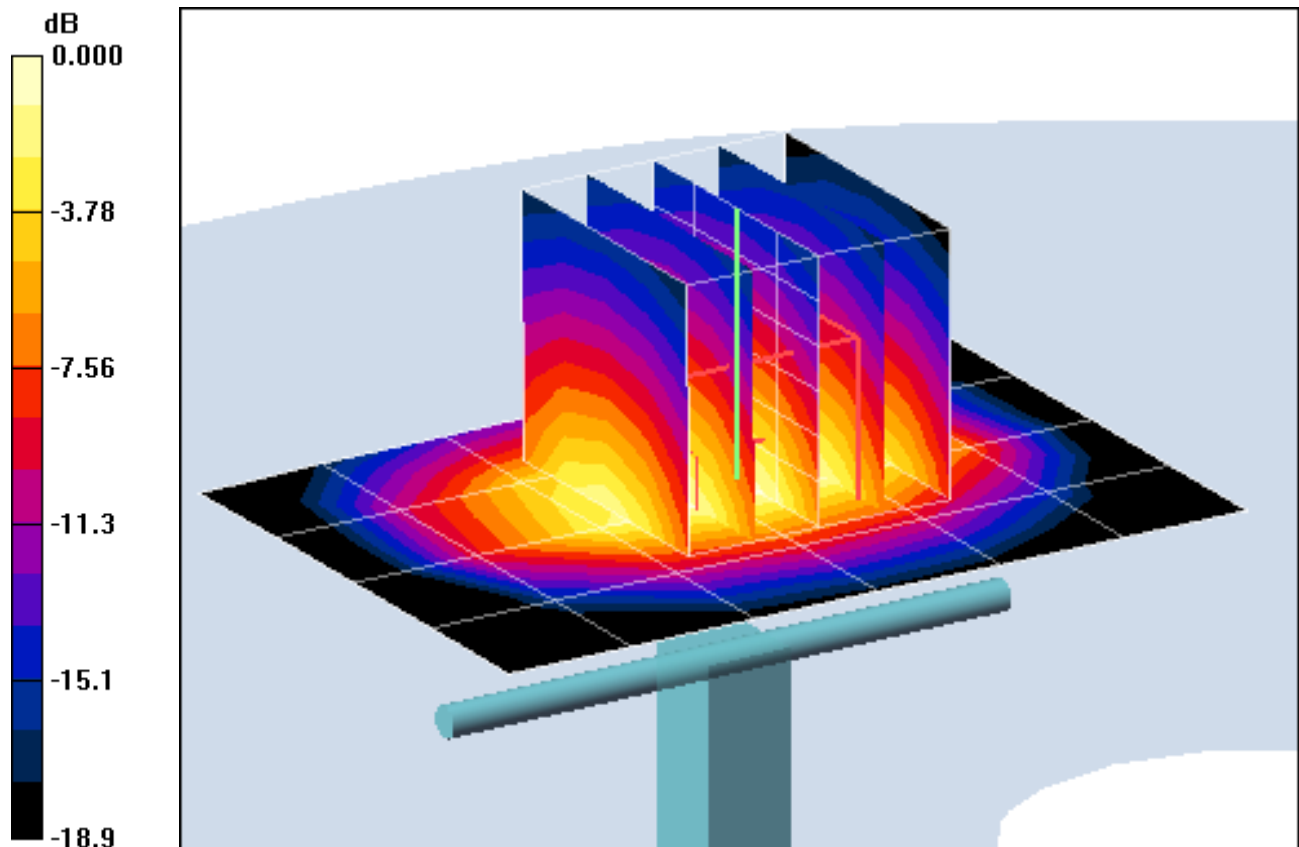

0 dB = 1.82mW/g

PCTEST ENGINEERING LABORATORY, INC.

DUT: SAR Dipole 1900 MHz; Type: D1900V2; Serial: 502

Communication System: CW; Frequency: 1900 MHz; Duty Cycle: 1:1

Medium: 1900 Body Medium parameters used (interpolated):

$f = 1900 \text{ MHz}$; $\sigma = 1.56 \text{ mho/m}$; $\epsilon_r = 52.5$; $\rho = 1000 \text{ kg/m}^3$

Phantom section: Flat Section; Space: 1.0 cm

Test Date: 05-03-2011; Ambient Temp: 23.3°C; Tissue Temp: 22.2°C

Probe: EX3DV4 - SN3561; ConvF(6.59, 6.59, 6.59); Calibrated: 8/19/2010

Sensor-Surface: 4mm (Mechanical Surface Detection)

Electronics: DAE4 Sn649; Calibrated: 2/21/2011

Phantom: SAM Sub; Type: SAM 4.0; Serial: TP-1357

Measurement SW: DASY4, V4.7 Build 80; Postprocessing SW: SEMCAD, V1.8 Build 186

1900MHz System Verification

Area Scan (5x7x1): Measurement grid: dx=15mm, dy=15mm

Zoom Scan (5x5x7)/Cube 0: Measurement grid: dx=8mm, dy=8mm, dz=5mm

Input Power = 16 dBm (40 mW)

SAR(1 g) = 1.7 mW/g; SAR(10 g) = 0.877 mW/g

Deviation = 3.41 %

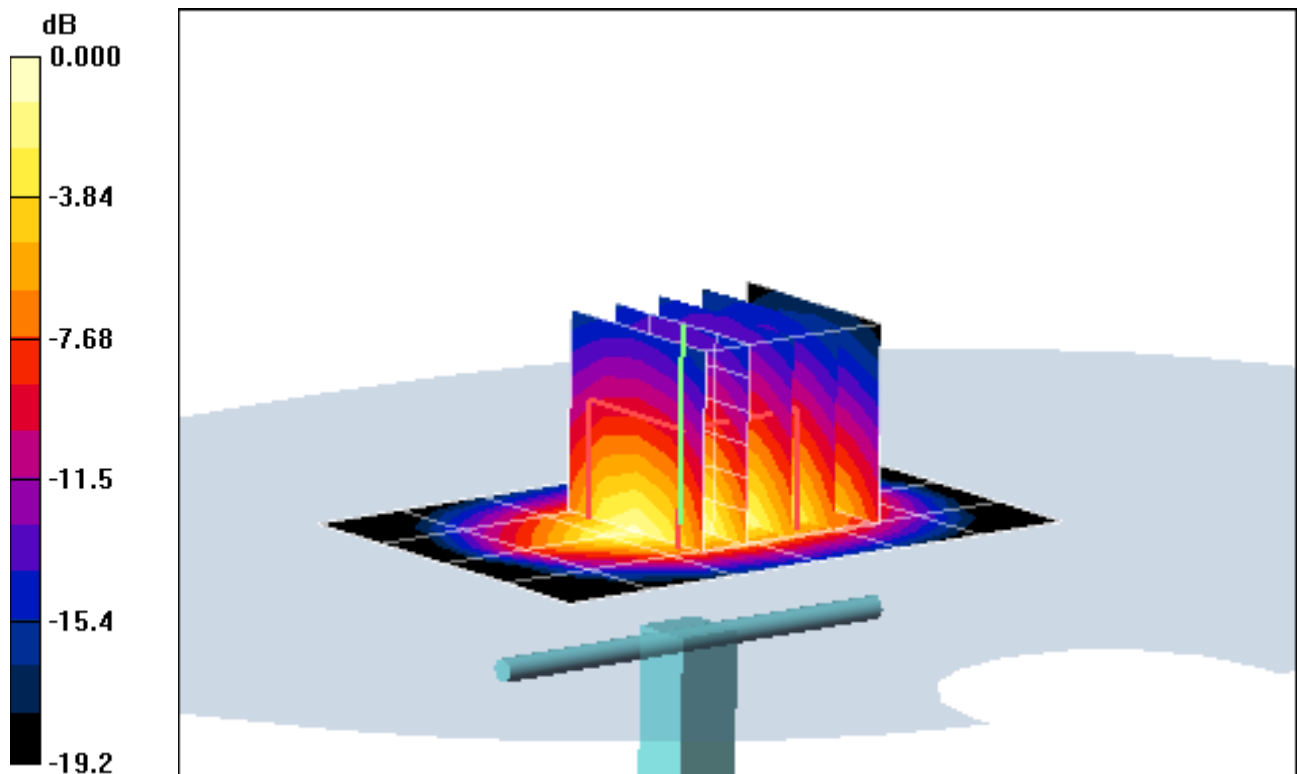

0 dB = 1.92mW/g

PCTEST ENGINEERING LABORATORY, INC.

DUT: SAR Dipole 2450 MHz; Type: D2450V2; Serial: 797

Communication System: CW; Frequency: 2450 MHz; Duty Cycle: 1:1

Medium: 2450 Head; Medium parameters used:

$f = 2450 \text{ MHz}$; $\sigma = 1.89 \text{ mho/m}$; $\epsilon_r = 37.4$; $\rho = 1000 \text{ kg/m}^3$

Phantom section: Flat Section; Space: 1.0 cm

Test Date: 05-03-2011; Ambient Temp: 23.3°C; Tissue Temp: 22°C

Probe: EX3DV4 - SN3550; ConvF(6.29, 6.29, 6.29); Calibrated: 2/14/2011

Sensor-Surface: 3mm (Mechanical Surface Detection)

Electronics: DAE4 Sn859; Calibrated: 7/8/2010

Phantom: SAM Main; Type: SAM 4.0; Serial: TP-1114

Measurement SW: DASY4, V4.7 Build 80; Postprocessing SW: SEMCAD, V1.8 Build 186

2450MHz System Verification

Area Scan (5x7x1): Measurement grid: dx=15mm, dy=15mm

Zoom Scan (5x5x7)/Cube 0: Measurement grid: dx=8mm, dy=8mm, dz=5mm

Input Power = 14.0 dBm (25 mW)

SAR(1 g) = 1.41 mW/g; SAR(10 g) = 0.642 mW/g

Deviation = 5.82 %

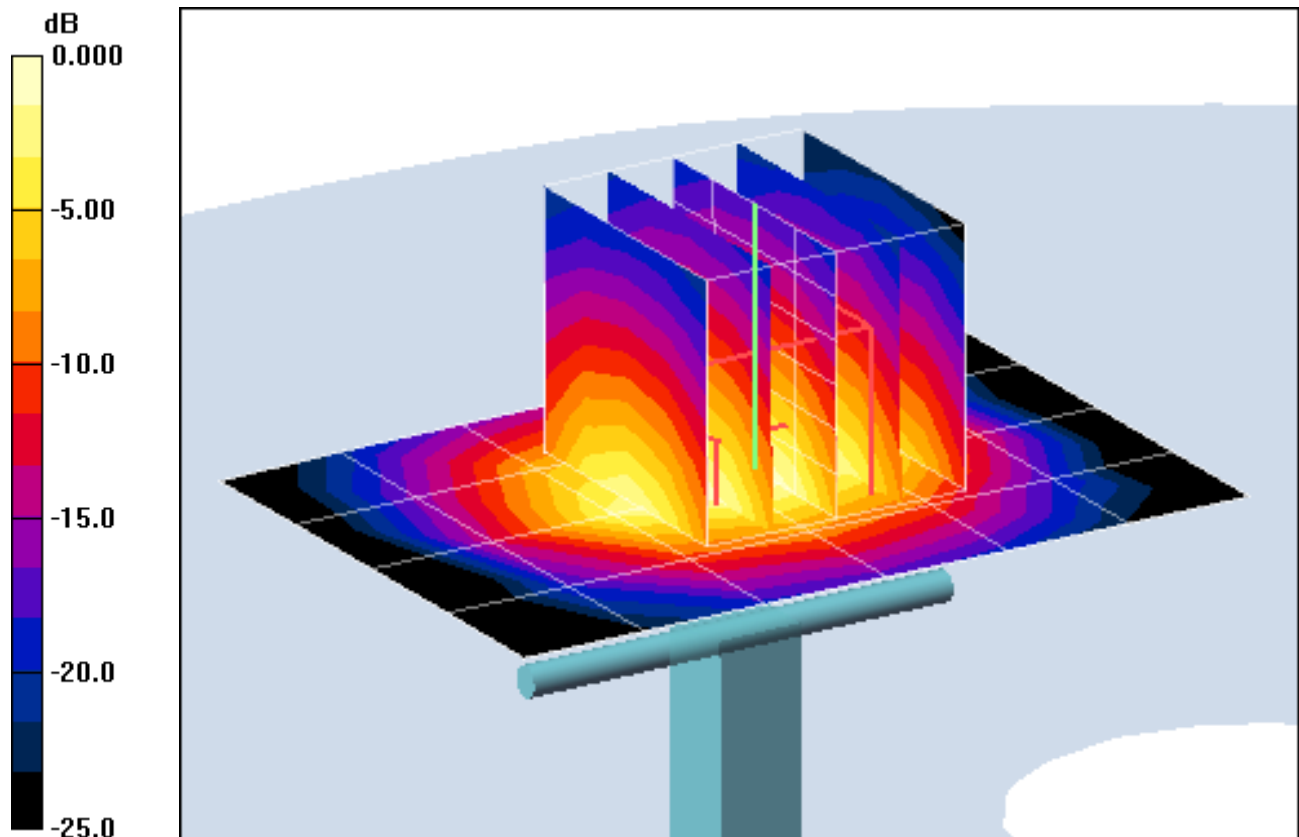

0 dB = 1.79mW/g

PCTEST ENGINEERING LABORATORY, INC.

DUT: SAR Dipole 2450 MHz; Type: D2450V2; Serial: 797

Communication System: CW; Frequency: 2450 MHz; Duty Cycle: 1:1

Medium: 2450 Body; Medium parameters used:

$f = 2450 \text{ MHz}$; $\sigma = 2.01 \text{ mho/m}$; $\epsilon_r = 50.2$; $\rho = 1000 \text{ kg/m}^3$

Phantom section: Flat Section; Space: 1.0 cm

Test Date: 05-02-2011; Ambient Temp: 24.3°C; Tissue Temp: 22.6° C

Probe: EX3DV4 - SN3550; ConvF(6.25, 6.25, 6.25); Calibrated: 2/14/2011

Sensor-Surface: 3mm (Mechanical Surface Detection)

Electronics: DAE4 Sn859; Calibrated: 7/8/2010

Phantom: SAM Sub; Type: SAM 4.0; Serial: TP-1357

Measurement SW: DASY4, V4.7 Build 80; Postprocessing SW: SEMCAD, V1.8 Build 186

2450MHz System Verification

Area Scan (5x7x1): Measurement grid: dx=15mm, dy=15mm

Zoom Scan (5x5x7)/Cube 0: Measurement grid: dx=8mm, dy=8mm, dz=5mm

Input Power = 14 dBm (25 mW)

SAR(1 g) = 1.28 mW/g; SAR(10 g) = 0.594 mW/g

Deviation = -2.10 %

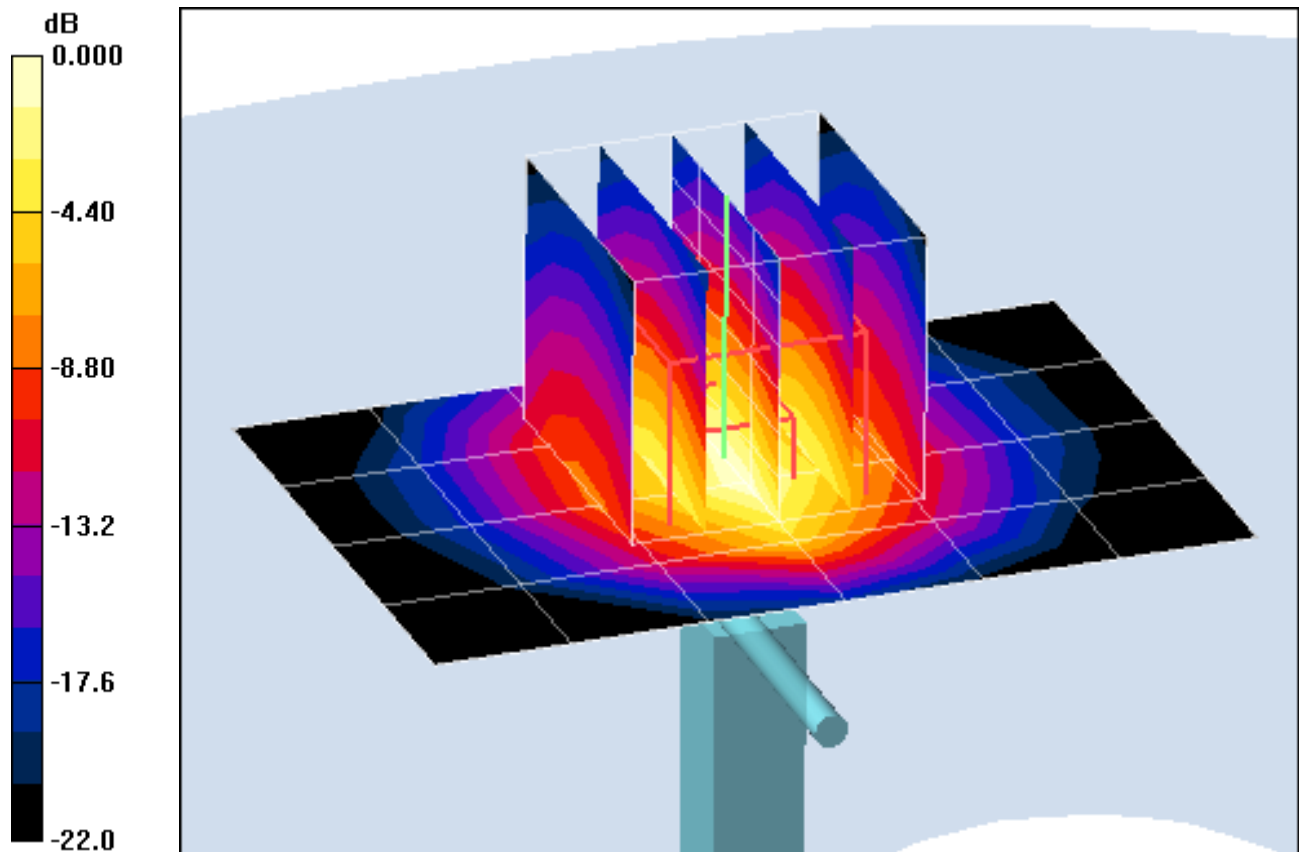

0 dB = 1.69mW/g

PCTEST ENGINEERING LABORATORY, INC.

DUT: Dipole 5200 MHz; Type: D5GHzV2; Serial: 1057

Communication System: CW; Frequency: 5200 MHz; Duty Cycle: 1:1

Medium: 5 GHz Head; Medium parameters used (interpolated):

$f = 5200 \text{ MHz}$; $\sigma = 4.75 \text{ mho/m}$; $\epsilon_r = 37.3$; $\rho = 1000 \text{ kg/m}^3$

Phantom section: Flat Section; Space: 1.0 cm

Test Date: 05-04-2011; Ambient Temp: 24.3°C ; Tissue Temp: 22.8°C

Probe: EX3DV4 - SN3550; ConvF(4.06, 4.06, 4.06); Calibrated: 2/14/2011

Sensor-Surface: 2mm (Mechanical Surface Detection)

Electronics: DAE4 Sn859; Calibrated: 7/8/2010

Phantom: SAM Main; Type: SAM 4.0; Serial: TP-1114

Measurement SW: DASY4, V4.7 Build 80; Postprocessing SW: SEMCAD, V1.8 Build 186

5200MHz System Verification

Area Scan (7x9x1): Measurement grid: dx=10mm, dy=10mm

Zoom Scan (7x7x11)/Cube 0: Measurement grid: dx=4mm, dy=4mm, dz=2mm

Input Power = 14 dBm (25 mW)

SAR(1 g) = 2.2 mW/g; SAR(10 g) = 0.628 mW/g

Deviation = 5.90 %

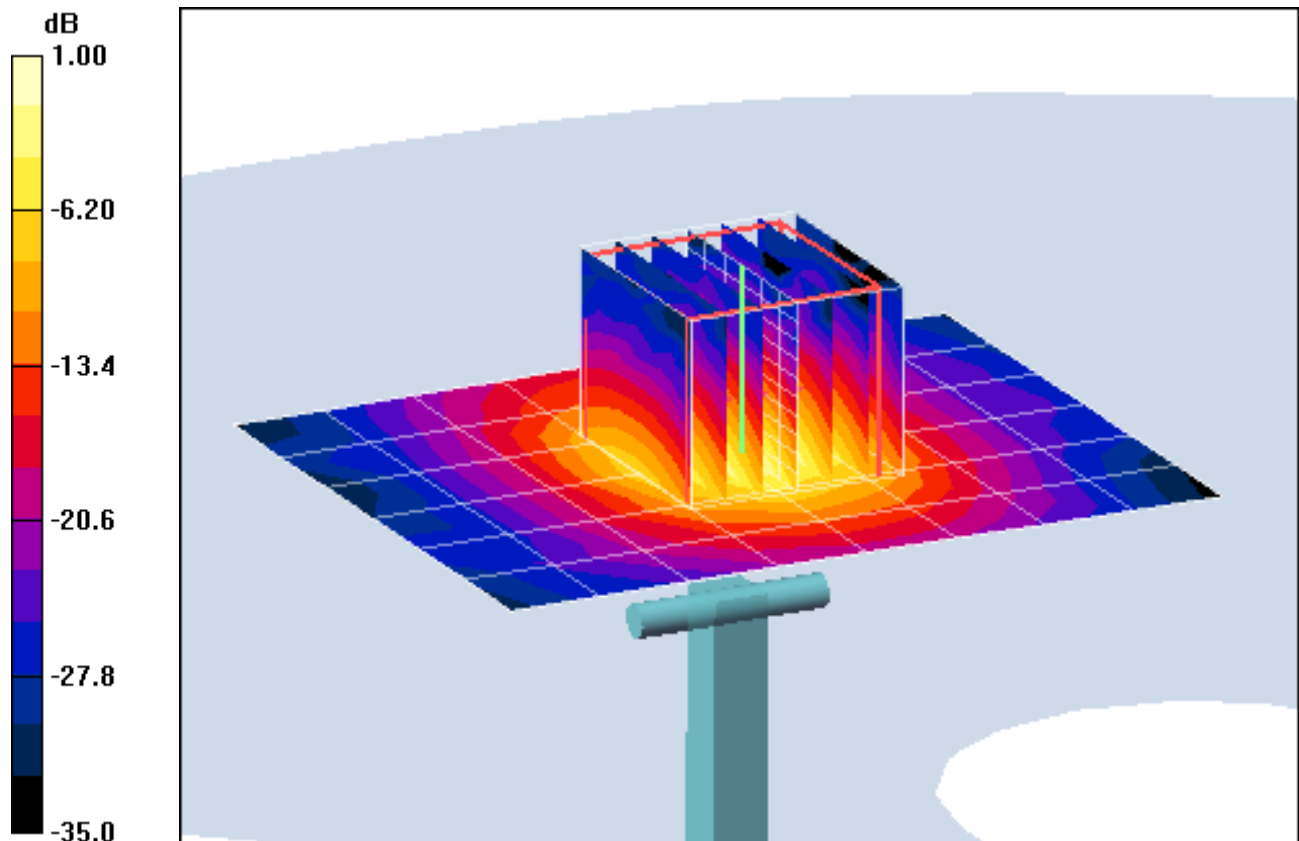

0 dB = 4.50mW/g

PCTEST ENGINEERING LABORATORY, INC.

DUT: Dipole 5200 MHz; Type: D5GHzV2; Serial: 1057

Communication System: CW; Frequency: 5200 MHz; Duty Cycle: 1:1

Medium: 5 GHz Body; Medium parameters used (interpolated):

$f = 5200 \text{ MHz}$; $\sigma = 5.3 \text{ mho/m}$; $\epsilon_r = 49$; $\rho = 1000 \text{ kg/m}^3$

Phantom section: Flat Section; Space: 1.0 cm

Test Date: 05-04-2011; Ambient Temp: 24.3°C ; Tissue Temp: 22.6°C

Probe: EX3DV4 - SN3550; ConvF(3.58, 3.58, 3.58); Calibrated: 2/14/2011

Sensor-Surface: 2mm (Mechanical Surface Detection)

Electronics: DAE4 Sn859; Calibrated: 7/8/2010

Phantom: SAM Main; Type: SAM 4.0; Serial: TP-1114

Measurement SW: DASY4, V4.7 Build 80; Postprocessing SW: SEMCAD, V1.8 Build 186

5200MHz System Verification

Area Scan (7x9x1): Measurement grid: dx=10mm, dy=10mm

Zoom Scan (7x7x11)/Cube 0: Measurement grid: dx=4mm, dy=4mm, dz=2mm

Input Power = 14 dBm (25 mW)

SAR(1 g) = 2.01 mW/g; SAR(10 g) = 0.558 mW/g

Deviation = 3.47 %

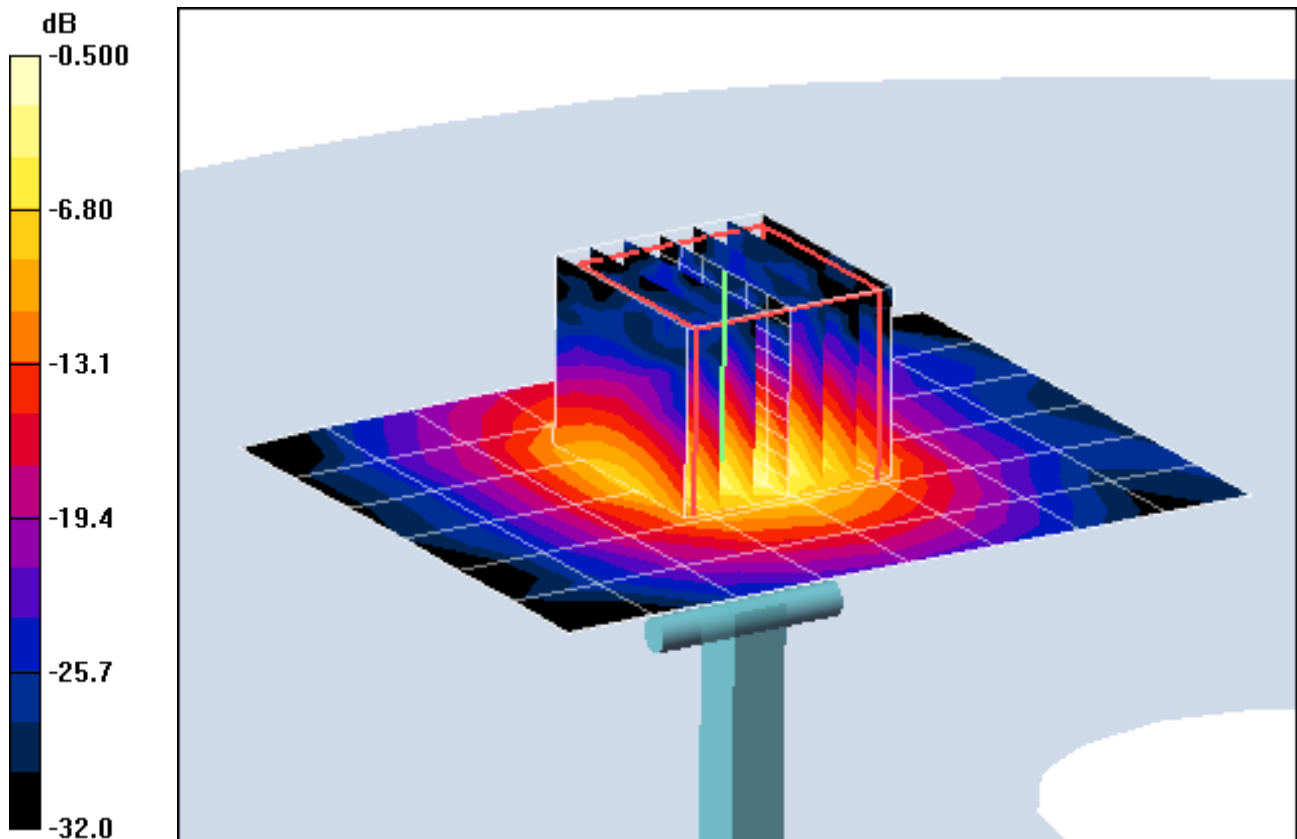

0 dB = 4.27mW/g

PCTEST ENGINEERING LABORATORY, INC.

DUT: Dipole 5500 MHz; Type: D5GHzV2; Serial: 1057

Communication System: CW; Frequency: 5500 MHz; Duty Cycle: 1:1

Medium: 5 GHz Head; Medium parameters used (interpolated):

$f = 5500 \text{ MHz}$; $\sigma = 5.15 \text{ mho/m}$; $\epsilon_r = 36.7$; $\rho = 1000 \text{ kg/m}^3$

Phantom section: Flat Section; Space: 1.0 cm

Test Date: 05-04-2011; Ambient Temp: 23.4°C ; Tissue Temp: 22.5°C

Probe: EX3DV4 - SN3550; ConvF(3.77, 3.77, 3.77); Calibrated: 2/14/2011

Sensor-Surface: 2mm (Mechanical Surface Detection)

Electronics: DAE4 Sn859; Calibrated: 7/8/2010

Phantom: SAM Main; Type: SAM 4.0; Serial: TP-1114

Measurement SW: DASY4, V4.7 Build 80; Postprocessing SW: SEMCAD, V1.8 Build 186

5500MHz System Verification

Area Scan (7x9x1): Measurement grid: dx=10mm, dy=10mm

Zoom Scan (7x7x11)/Cube 0: Measurement grid: dx=4mm, dy=4mm, dz=2mm

Input Power = 14 dBm (25 mW)

SAR(1 g) = 2.27 mW/g; SAR(10 g) = 0.632 mW/g

Deviation = 0.78 %

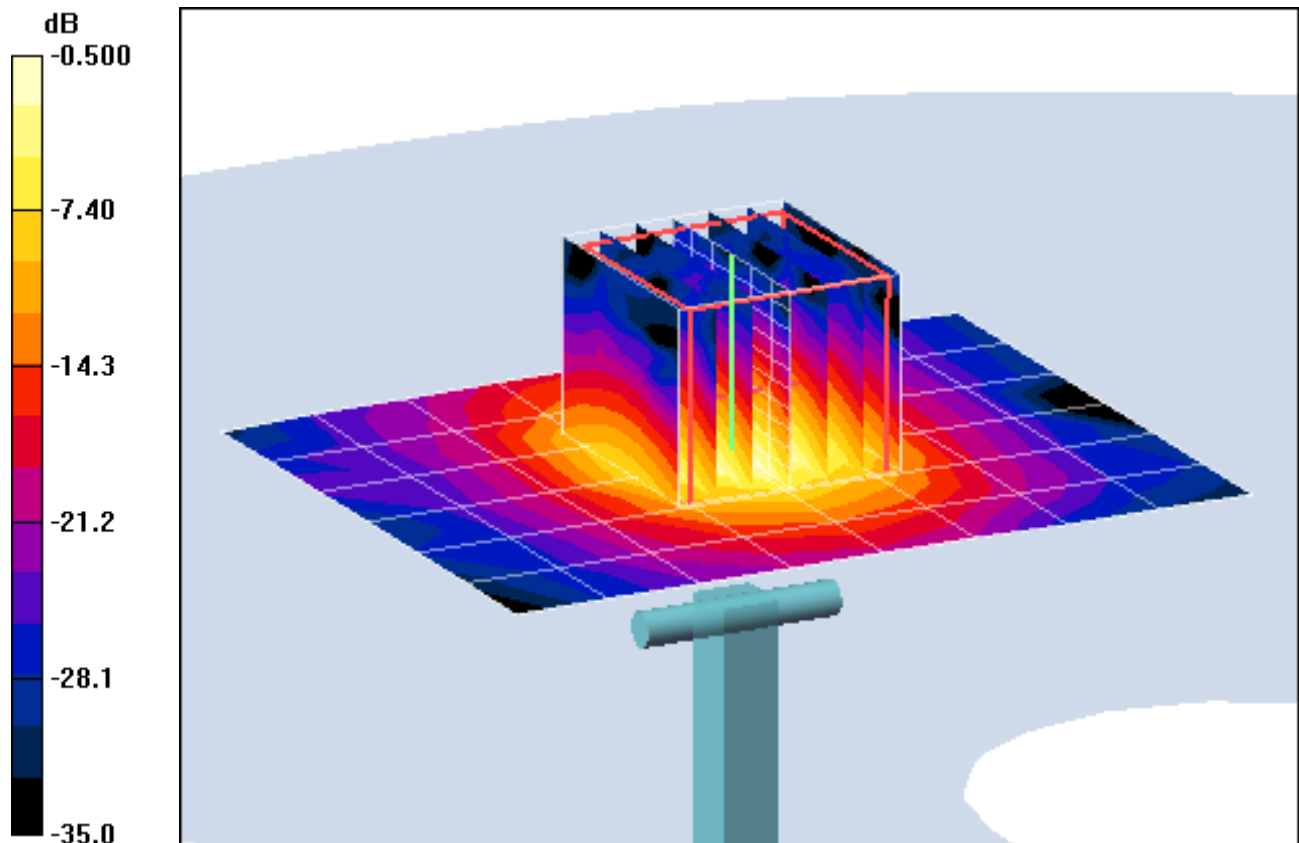

0 dB = 4.78mW/g

PCTEST ENGINEERING LABORATORY, INC.

DUT: Dipole 5500 MHz; Type: D5GHzV2; Serial: 1057

Communication System: CW; Frequency: 5500 MHz; Duty Cycle: 1:1

Medium: 5 GHz Body; Medium parameters used (interpolated):

$f = 5500 \text{ MHz}$; $\sigma = 5.75 \text{ mho/m}$; $\epsilon_r = 48.4$; $\rho = 1000 \text{ kg/m}^3$

Phantom section: Flat Section ; Space: 1.0 cm

Test Date: 05-04-2011; Ambient Temp: 24.5°C ; Tissue Temp: 22.7°C

Probe: EX3DV4 - SN3550; ConvF(3.21, 3.21, 3.21); Calibrated: 2/14/2011

Sensor-Surface: 2mm (Mechanical Surface Detection)

Electronics: DAE4 Sn859; Calibrated: 7/8/2010

Phantom: SAM Main; Type: SAM 4.0; Serial: TP-1114

Measurement SW: DASY4, V4.7 Build 80; Postprocessing SW: SEMCAD, V1.8 Build 186

5500MHz System Verification

Area Scan (7x9x1): Measurement grid: dx=10mm, dy=10mm

Zoom Scan (7x7x11)/Cube 0: Measurement grid: dx=4mm, dy=4mm, dz=2mm

Input Power = 14 dBm (25 mW)

SAR(1 g) = 2.13 mW/g; SAR(10 g) = 0.567 mW/g

Deviation = 0.; 7 %

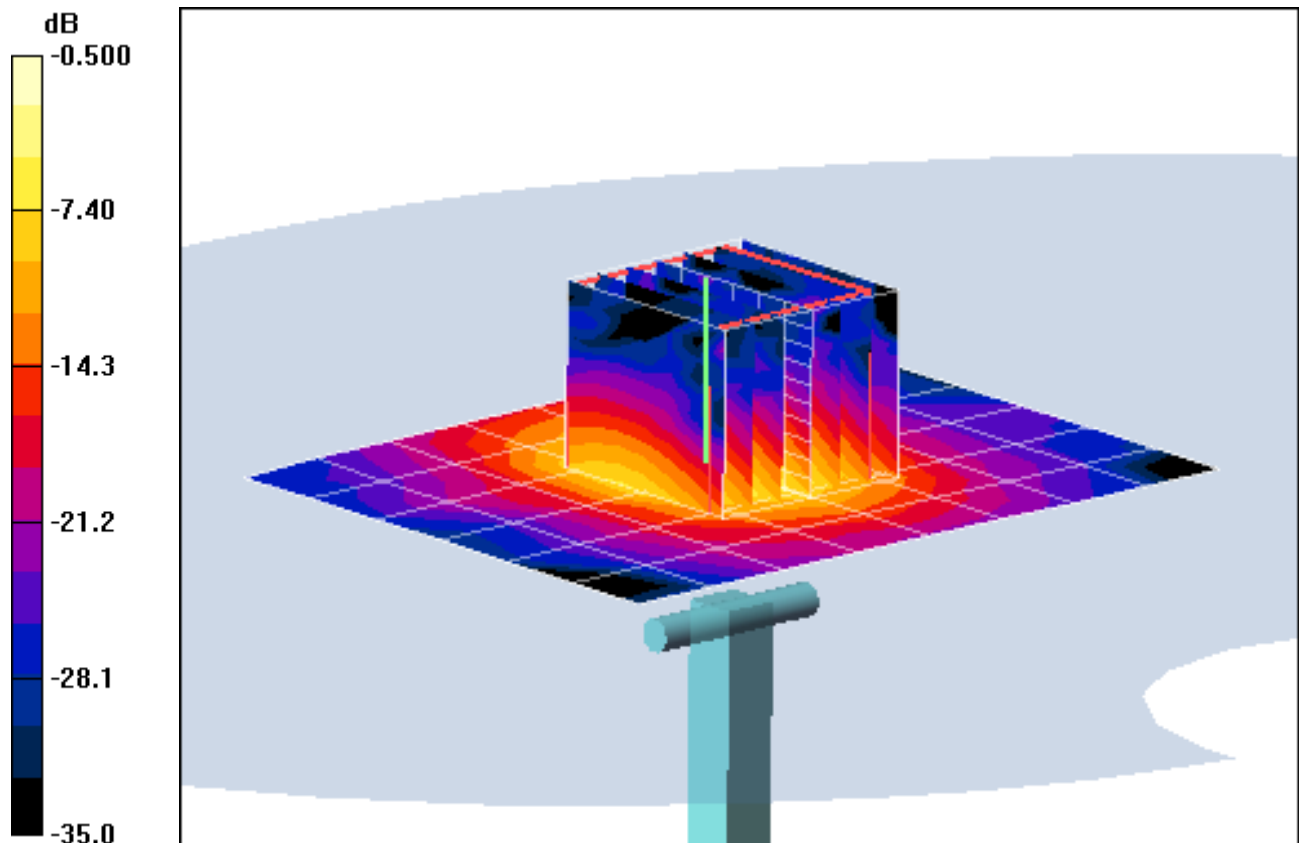

0 dB = 4.57mW/g

PCTEST ENGINEERING LABORATORY, INC.

DUT: Dipole 5800 MHz; Type: D5GHzV2; Serial: 1057

Communication System: CW; Frequency: 5800 MHz; Duty Cycle: 1:1

Medium: 5 GHz Head Medium parameters used (interpolated):

$f = 5800 \text{ MHz}$; $\sigma = 5.5 \text{ mho/m}$; $\epsilon_r = 36$; $\rho = 1000 \text{ kg/m}^3$

Phantom section: Flat Section; Space: 1.0 cm

Test Date: 05-04-2011; Ambient Temp: 23.9°C ; Tissue Temp: 22.8°C

Probe: EX3DV4 - SN3550; ConvF(3.64, 3.64, 3.64); Calibrated: 2/14/2011

Sensor-Surface: 2mm (Mechanical Surface Detection)

Electronics: DAE4 Sn859; Calibrated: 7/8/2010

Phantom: SAM Main; Type: SAM 4.0; Serial: TP-1114

Measurement SW: DASY4, V4.7 Build 80; Postprocessing SW: SEMCAD, V1.8 Build 186

5800MHz System Verification

Area Scan (7x9x1): Measurement grid: dx=10mm, dy=10mm

Zoom Scan (7x7x11)/Cube 0: Measurement grid: dx=4mm, dy=4mm, dz=2mm

Input Power = 14.0 dBm (25 mW)

SAR(1 g) = 2.15 mW/g; SAR(10 g) = 0.594 mW/g

Deviation = 3.74 %

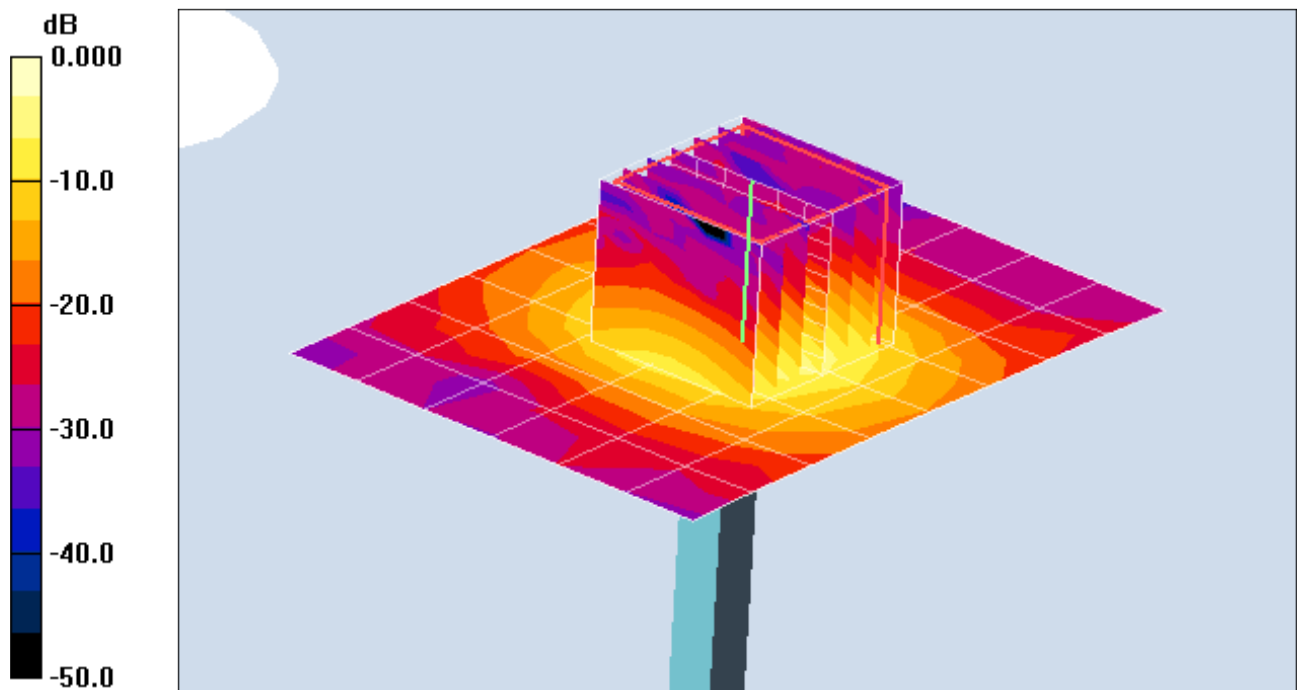

0 dB = 4.72mW/g

PCTEST ENGINEERING LABORATORY, INC.

DUT: Dipole 5800 MHz; Type: D5GHzV2; Serial: 1057

Communication System: CW; Frequency: 5800 MHz; Duty Cycle: 1:1

Medium: 5 GHz Body; Medium parameters used (interpolated):

$f = 5800 \text{ MHz}$; $\sigma = 6.17 \text{ mho/m}$; $\epsilon_r = 47.7$; $\rho = 1000 \text{ kg/m}^3$

Phantom section: Flat Section; Space: 1.0 cm

Test Date: 05-04-2011; Ambient Temp: 24.6°C ; Tissue Temp: 22.9°C

Probe: EX3DV4 - SN3550; ConvF(3.29, 3.29, 3.29); Calibrated: 2/14/2011

Sensor-Surface: 2mm (Mechanical Surface Detection)

Electronics: DAE4 Sn859; Calibrated: 7/8/2010

Phantom: SAM Main; Type: SAM 4.0; Serial: TP-1114

Measurement SW: DASY4, V4.7 Build 80; Postprocessing SW: SEMCAD, V1.8 Build 186

5800MHz System Verification

Area Scan (7x9x1): Measurement grid: dx=10mm, dy=10mm

Zoom Scan (7x7x11)/Cube 0: Measurement grid: dx=4mm, dy=4mm, dz=2mm

Input Power = 14 dBm (25 mW)

SAR(1 g) = 1.94 mW/g; SAR(10 g) = 0.531 mW/g

Deviation = 3.47 %

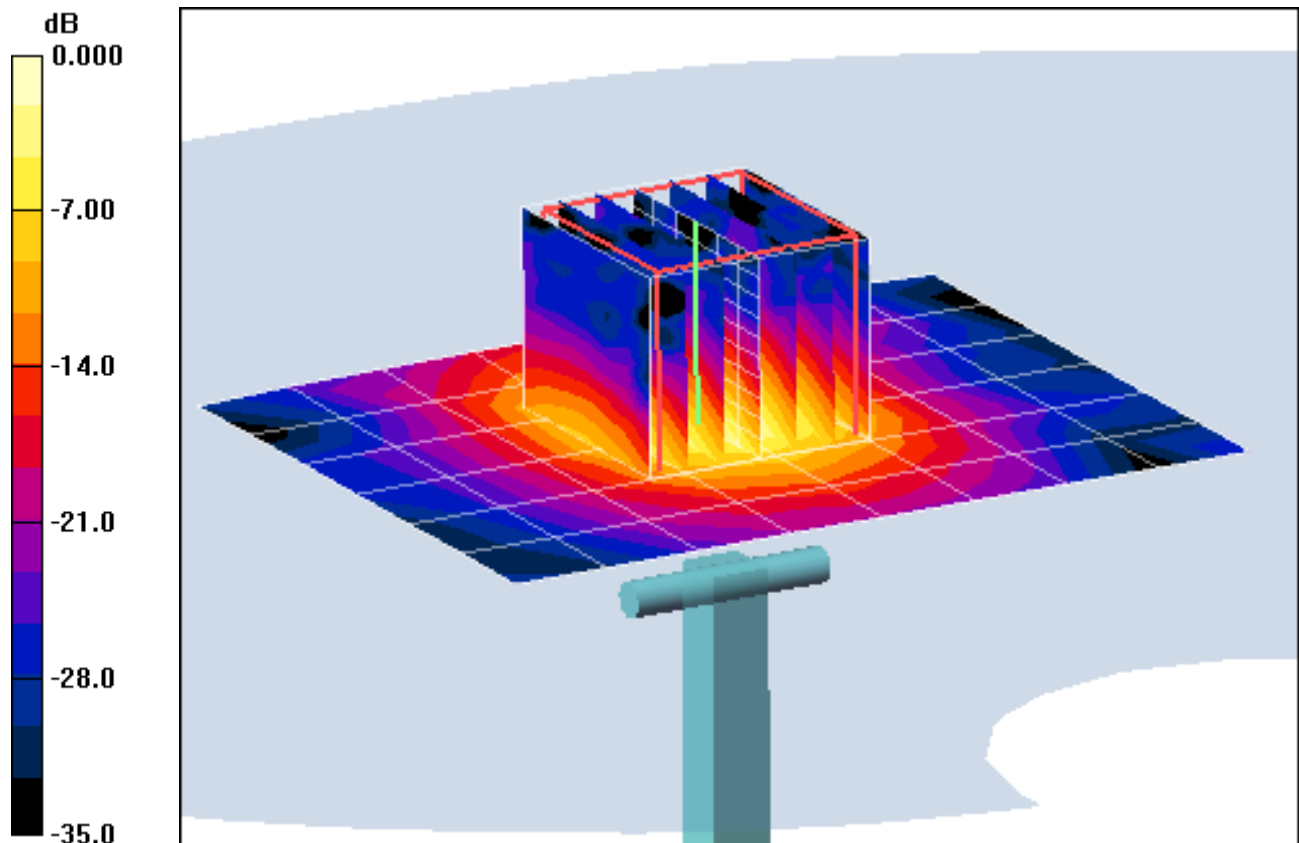

0 dB = 4.04mW/g

APPENDIX C: PROBE CALIBRATION



Accredited by the Swiss Accreditation Service (SAS)
The Swiss Accreditation Service is one of the signatories to the EA
Multilateral Agreement for the recognition of calibration certificates

Accreditation No.: **SCS 108**

Client **PC Test**

Certificate No: **D5GHzV2-1057_Feb11/2**

CALIBRATION CERTIFICATE (Replacement of No: D5GHzV2-1057_Feb11)

Object **D5GHzV2 - SN: 1057**

Calibration procedure(s) **QA CAL-22.v1
Calibration procedure for dipole validation kits between 3-6 GHz**

Calibration date: **February 11, 2011**

✓
KOK
2/24/11

This calibration certificate documents the traceability to national standards, which realize the physical units of measurements (SI).
The measurements and the uncertainties with confidence probability are given on the following pages and are part of the certificate.

All calibrations have been conducted in the closed laboratory facility: environment temperature (22 ± 3)°C and humidity < 70%.

Calibration Equipment used (M&TE critical for calibration)

Primary Standards	ID #	Cal Date (Certificate No.)	Scheduled Calibration
Power meter EPM-442A	GB37480704	06-Oct-10 (No. 217-01266)	Oct-11
Power sensor HP 8481A	US37292783	06-Oct-10 (No. 217-01266)	Oct-11
Reference 20 dB Attenuator	SN: 5086 (20g)	30-Mar-10 (No. 217-01158)	Mar-11
Type-N mismatch combination	SN: 5047.2 / 06327	30-Mar-10 (No. 217-01162)	Mar-11
Reference Probe EX3DV4	SN: 3503	05-Mar-10 (No. EX3-3503_Mar10)	Mar-11
DAE4	SN: 601	10-Jun-10 (No. DAE4-601_Jun10)	Jun-11
Secondary Standards	ID #	Check Date (in house)	Scheduled Check
Power sensor HP 8481A	MY41092317	18-Oct-02 (in house check Oct-09)	In house check: Oct-11
RF generator R&S SMT-06	100005	4-Aug-99 (in house check Oct-09)	In house check: Oct-11
Network Analyzer HP 8753E	US37390585 S4206	18-Oct-01 (in house check Oct-10)	In house check: Oct-11

Calibrated by: **Name: Jeton Kastrati, Function: Laboratory Technician, Signature: [Handwritten Signature]**

Approved by: **Name: Kalja Pokovic, Function: Technical Manager, Signature: [Handwritten Signature]**

Issued: February 23, 2011

This calibration certificate shall not be reproduced except in full without written approval of the laboratory.



Accredited by the Swiss Accreditation Service (SAS)

Accreditation No.: **SCS 108**

The Swiss Accreditation Service is one of the signatories to the EA
Multilateral Agreement for the recognition of calibration certificates

Glossary:

TSL	tissue simulating liquid
ConvF	sensitivity in TSL / NORM x,y,z
N/A	not applicable or not measured

Calibration is Performed According to the Following Standards:

- a) IEC 62209-2, "Evaluation of Human Exposure to Radio Frequency Fields from Handheld and Body-Mounted Wireless Communication Devices in the Frequency Range of 30 MHz to 6 GHz: Human models, Instrumentation, and Procedures"; Part 2: "Procedure to determine the Specific Absorption Rate (SAR) for including accessories and multiple transmitters", March 2010
- b) Federal Communications Commission Office of Engineering & Technology (FCC OET), "Evaluating Compliance with FCC Guidelines for Human Exposure to Radiofrequency Electromagnetic Fields; Additional Information for Evaluating Compliance of Mobile and Portable Devices with FCC Limits for Human Exposure to Radiofrequency Emissions", Supplement C (Edition 01-01) to Bulletin 65

Additional Documentation:

- c) DASY4/5 System Handbook

Methods Applied and Interpretation of Parameters:

- *Measurement Conditions:* Further details are available from the Validation Report at the end of the certificate. All figures stated in the certificate are valid at the frequency indicated.
- *Antenna Parameters with TSL:* The dipole is mounted with the spacer to position its feed point exactly below the center marking of the flat phantom section, with the arms oriented parallel to the body axis.
- *Feed Point Impedance and Return Loss:* These parameters are measured with the dipole positioned under the liquid filled phantom. The impedance stated is transformed from the measurement at the SMA connector to the feed point. The Return Loss ensures low reflected power. No uncertainty required.
- *Electrical Delay:* One-way delay between the SMA connector and the antenna feed point. No uncertainty required.
- *SAR measured:* SAR measured at the stated antenna input power.
- *SAR normalized:* SAR as measured, normalized to an input power of 1 W at the antenna connector.
- *SAR for nominal TSL parameters:* The measured TSL parameters are used to calculate the nominal SAR result.

Measurement Conditions

DASY system configuration, as far as not given on page 1.

DASY Version	DASY5	V52.6
Extrapolation	Advanced Extrapolation	
Phantom	Modular Flat Phantom V5.0	
Distance Dipole Center - TSL	10 mm	with Spacer
Area Scan resolution	dx, dy = 10 mm	
Zoom Scan Resolution	dx, dy = 4.0 mm, dz = 2.0 mm	
Frequency	5200 MHz ± 1 MHz 5500 MHz ± 1 MHz 5800 MHz ± 1 MHz	

Head TSL parameters at 5200 MHz

The following parameters and calculations were applied.

	Temperature	Permittivity	Conductivity
Nominal Head TSL parameters	22.0 °C	36.0	4.66 mho/m
Measured Head TSL parameters	(22.0 ± 0.2) °C	36.5 ± 6 %	4.56 mho/m ± 6 %
Head TSL temperature during test	(22.1 ± 0.2) °C	----	----

SAR result with Head TSL at 5200 MHz

SAR averaged over 1 cm ³ (1 g) of Head TSL	condition	
SAR measured	100 mW input power	8.29 mW / g
SAR normalized	normalized to 1W	82.9 mW / g
SAR for nominal Head TSL parameters	normalized to 1W	83.1 mW / g ± 19.9 % (k=2)

SAR averaged over 10 cm ³ (10 g) of Head TSL	condition	
SAR measured	100 mW input power	2.35 mW / g
SAR normalized	normalized to 1W	23.5 mW / g
SAR for nominal Head TSL parameters	normalized to 1W	23.5 mW / g ± 19.5 % (k=2)

Head TSL parameters at 5500 MHz

The following parameters and calculations were applied.

	Temperature	Permittivity	Conductivity
Nominal Head TSL parameters	22.0 °C	35.6	4.96 mho/m
Measured Head TSL parameters	(22.0 ± 0.2) °C	36.0 ± 6 %	4.86 mho/m ± 6 %
Head TSL temperature during test	(22.1 ± 0.2) °C	----	----

SAR result with Head TSL at 5500 MHz

SAR averaged over 1 cm ³ (1 g) of Head TSL	condition	
SAR measured	100 mW input power	9.00 mW / g
SAR normalized	normalized to 1W	90.0 mW / g
SAR for nominal Head TSL parameters	normalized to 1W	90.1 mW / g ± 19.9 % (k=2)

SAR averaged over 10 cm ³ (10 g) of Head TSL	condition	
SAR measured	100 mW input power	2.53 mW / g
SAR normalized	normalized to 1W	25.3 mW / g
SAR for nominal Head TSL parameters	normalized to 1W	25.3 mW / g ± 19.5 % (k=2)

Head TSL parameters at 5800 MHz

The following parameters and calculations were applied.

	Temperature	Permittivity	Conductivity
Nominal Head TSL parameters	22.0 °C	35.3	5.27 mho/m
Measured Head TSL parameters	(22.0 ± 0.2) °C	35.6 ± 6 %	5.17 mho/m ± 6 %
Head TSL temperature during test	(22.1 ± 0.2) °C	----	----

SAR result with Head TSL at 5800 MHz

SAR averaged over 1 cm ³ (1 g) of Head TSL	condition	
SAR measured	100 mW input power	8.28 mW / g
SAR normalized	normalized to 1W	82.8 mW / g
SAR for nominal Head TSL parameters	normalized to 1W	82.9 mW / g ± 19.9 % (k=2)

SAR averaged over 10 cm ³ (10 g) of Head TSL	condition	
SAR measured	100 mW input power	2.33 mW / g
SAR normalized	normalized to 1W	23.3 mW / g
SAR for nominal Head TSL parameters	normalized to 1W	23.3 mW / g ± 19.5 % (k=2)

Body TSL parameters at 5200 MHz

The following parameters and calculations were applied.

	Temperature	Permittivity	Conductivity
Nominal Body TSL parameters	22.0 °C	49.0	5.30 mho/m
Measured Body TSL parameters	(22.0 ± 0.2) °C	47.2 ± 6 %	5.37 mho/m ± 6 %
Body TSL temperature during test	(22.0 ± 0.2) °C	----	----

SAR result with Body TSL at 5200 MHz

SAR averaged over 1 cm ³ (1 g) of Body TSL	condition	
SAR measured	100 mW input power	7.83 mW / g
SAR normalized	normalized to 1W	78.3 mW / g
SAR for nominal Body TSL parameters	normalized to 1W	77.7 mW / g ± 19.9 % (k=2)

SAR averaged over 10 cm ³ (10 g) of Body TSL	condition	
SAR measured	100 mW input power	2.17 mW / g
SAR normalized	normalized to 1W	21.7 mW / g
SAR for nominal Body TSL parameters	normalized to 1W	21.5 mW / g ± 19.5 % (k=2)

Body TSL parameters at 5500 MHz

The following parameters and calculations were applied.

	Temperature	Permittivity	Conductivity
Nominal Body TSL parameters	22.0 °C	48.6	5.65 mho/m
Measured Body TSL parameters	(22.0 ± 0.2) °C	46.6 ± 6 %	5.75 mho/m ± 6 %
Body TSL temperature during test	(22.0 ± 0.2) °C	----	----

SAR result with Body TSL at 5500 MHz

SAR averaged over 1 cm ³ (1 g) of Body TSL	condition	
SAR measured	100 mW input power	8.51 mW / g
SAR normalized	normalized to 1W	85.1 mW / g
SAR for nominal Body TSL parameters	normalized to 1W	84.4 mW / g ± 19.9 % (k=2)

SAR averaged over 10 cm ³ (10 g) of Body TSL	condition	
SAR measured	100 mW input power	2.34 mW / g
SAR normalized	normalized to 1W	23.4 mW / g
SAR for nominal Body TSL parameters	normalized to 1W	23.2 mW / g ± 19.5 % (k=2)

Body TSL parameters at 5800 MHz

The following parameters and calculations were applied.

	Temperature	Permittivity	Conductivity
Nominal Body TSL parameters	22.0 °C	48.2	6.00 mho/m
Measured Body TSL parameters	(22.0 ± 0.2) °C	46.1 ± 6 %	6.14 mho/m ± 6 %
Body TSL temperature during test	(21.5 ± 0.2) °C	----	----

SAR result with Body TSL at 5800 MHz

SAR averaged over 1 cm ³ (1 g) of Body TSL	condition	
SAR measured	100 mW input power	7.56 mW / g
SAR normalized	normalized to 1W	75.6 mW / g
SAR for nominal Body TSL parameters	normalized to 1W	75.0 mW / g ± 19.9 % (k=2)

SAR averaged over 10 cm ³ (10 g) of Body TSL	condition	
SAR measured	100 mW input power	2.07 mW / g
SAR normalized	normalized to 1W	20.7 mW / g
SAR for nominal Body TSL parameters	normalized to 1W	20.5 mW / g ± 19.5 % (k=2)

Appendix

Antenna Parameters with Head TSL at 5200 MHz

Impedance, transformed to feed point	50.2 Ω - 8.0 j Ω
Return Loss	-22.0 dB

Antenna Parameters with Head TSL at 5500 MHz

Impedance, transformed to feed point	50.3 Ω - 4.9 j Ω
Return Loss	-26.3 dB

Antenna Parameters with Head TSL at 5800 MHz

Impedance, transformed to feed point	51.9 Ω - 2.0 j Ω
Return Loss	-31.2 dB

Antenna Parameters with Body TSL at 5200 MHz

Impedance, transformed to feed point	50.9 Ω - 6.6 j Ω
Return Loss	-23.7 dB

Antenna Parameters with Body TSL at 5500 MHz

Impedance, transformed to feed point	50.5 Ω - 3.9 j Ω
Return Loss	-28.2 dB

Antenna Parameters with Body TSL at 5800 MHz

Impedance, transformed to feed point	52.0 Ω - 1.1 j Ω
Return Loss	-33.0 dB

General Antenna Parameters and Design

Electrical Delay (one direction)	1.204 ns
----------------------------------	----------

After long term use with 40 W radiated power, only a slight warming of the dipole near the feedpoint can be measured.

The dipole is made of standard semirigid coaxial cable. The center conductor of the feeding line is directly connected to the second arm of the dipole. The antenna is therefore short-circuited for DC-signals.

No excessive force must be applied to the dipole arms, because they might bend or the soldered connections near the feedpoint may be damaged.

Additional EUT Data

Manufactured by	SPEAG
Manufactured on	November 27, 2006

DASY5 Validation Report for Head TSL

Date/Time: 11.02.2011 14:44:40

Test Laboratory: SPEAG, Zurich, Switzerland

DUT: Dipole 5GHz; Type: D5GHz; Serial: D5GHzV2 - SN:1057

Communication System: CW; Frequency: 5200 MHz, Frequency: 5500 MHz, Frequency: 5800 MHz; Duty Cycle: 1:1

Medium: HSL 5000

Medium parameters used: $f = 5200$ MHz; $\sigma = 4.56$ mho/m; $\epsilon_r = 36.5$; $\rho = 1000$ kg/m³, Medium parameters used: $f = 5500$ MHz; $\sigma = 4.86$ mho/m; $\epsilon_r = 36$; $\rho = 1000$ kg/m³, Medium parameters used: $f = 5800$ MHz; $\sigma = 5.17$ mho/m; $\epsilon_r = 35.6$; $\rho = 1000$ kg/m³

Phantom section: Flat Section

Measurement Standard: DASY5 (IEEE/IEC/ANSI C63.19-2007)

DASY5 Configuration:

- Probe: EX3DV4 - SN3503; ConvF(5.36, 5.36, 5.36), ConvF(4.85, 4.85, 4.85), ConvF(4.74, 4.74, 4.74); Calibrated: 05.03.2010
- Sensor-Surface: 2mm (Mechanical Surface Detection)
- Electronics: DAE4 Sn601; Calibrated: 10.06.2010
- Phantom: Flat Phantom 5.0 (front); Type: QD000P50AA; Serial: 1001
- Measurement SW: DASY52, V52.6.1 Build (408)
- Postprocessing SW: SEMCAD X, V14.4.2 Build (2595)

Pin=100mW/d=10mm, f=5200 MHz/Zoom Scan (4x4x2mm), dist=2mm (8x8x6)/Cube 0:

Measurement grid: dx=4mm, dy=4mm, dz=2mm

Reference Value = 65.700 V/m; Power Drift = 0.03 dB

Peak SAR (extrapolated) = 31.538 W/kg

SAR(1 g) = 8.29 mW/g; SAR(10 g) = 2.35 mW/g

Maximum value of SAR (measured) = 16.059 mW/g

Pin=100mW/d=10mm, f=5500 MHz/Zoom Scan (4x4x2mm), dist=2mm (8x8x6)/Cube 0:

Measurement grid: dx=4mm, dy=4mm, dz=2mm

Reference Value = 67.167 V/m; Power Drift = 0.05 dB

Peak SAR (extrapolated) = 36.356 W/kg

SAR(1 g) = 9 mW/g; SAR(10 g) = 2.53 mW/g

Maximum value of SAR (measured) = 17.641 mW/g

Pin=100mW/d=10mm, f=5800 MHz/Zoom Scan (4x4x2mm), dist=2mm (8x8x6)/Cube 0:

Measurement grid: dx=4mm, dy=4mm, dz=2mm

Reference Value = 62.634 V/m; Power Drift = 0.04 dB

Peak SAR (extrapolated) = 34.882 W/kg

SAR(1 g) = 8.28 mW/g; SAR(10 g) = 2.33 mW/g

Maximum value of SAR (measured) = 16.490 mW/g

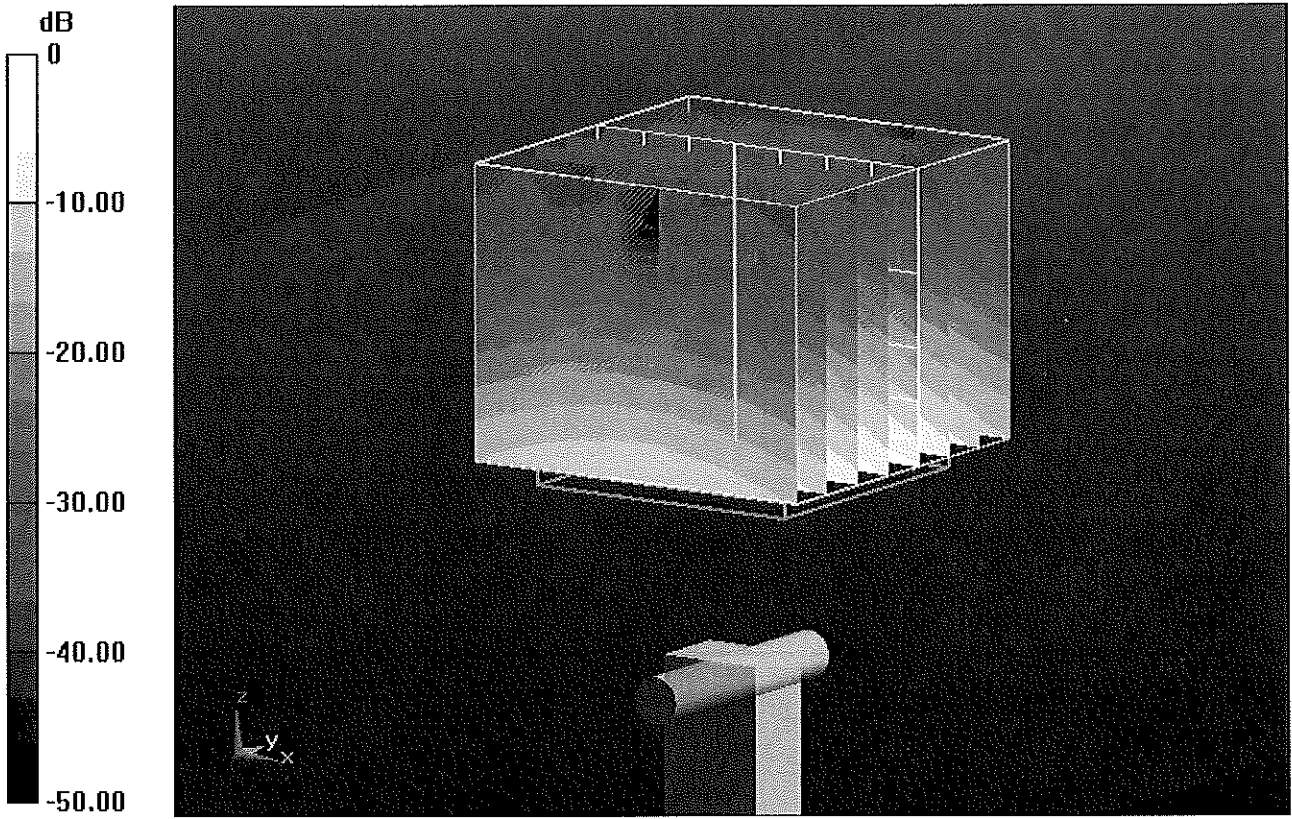

0 dB = 16.490mW/g

Impedance Measurement Plot for Head TSL

11 Feb 2011 10:17:21

[CH1] S11 1 U FS 1: 50.213 Ω -8.0234 Ω 3.8147 pF 5 200.000 000 MHz

*
Del
Cor
Avg
16
↑

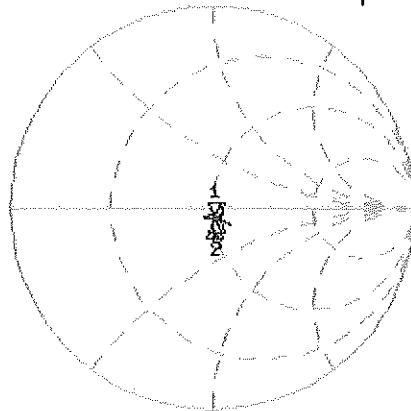

CH1 Markers
2: 50.336 Ω
-4.8613 Ω
5.50000 GHz
3: 51.936 Ω
-2.0254 Ω
5.80000 GHz

CH2 S11 LOG 5 dB/REF -20 dB 1:-21.957 dB 5 200.000 000 MHz

Cor
Avg
16
↑

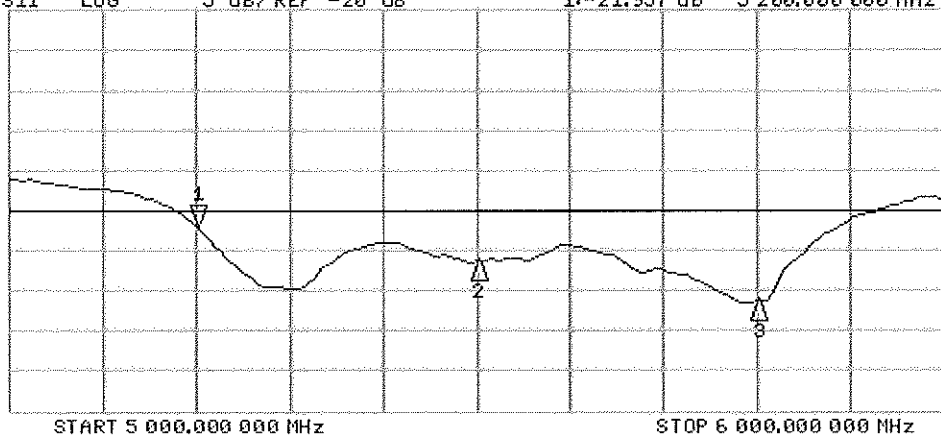

CH2 Markers
2:-26.280 dB
5.50000 GHz
3:-31.217 dB
5.80000 GHz

DASY5 Validation Report for Body TSL

Date/Time: 10.02.2011 17:14:02

Test Laboratory: SPEAG, Zurich, Switzerland

DUT: Dipole 5GHz; Type: D5GHz; Serial: D5GHzV2 - SN:1057

Communication System: CW; Frequency: 5200 MHz, Frequency: 5500 MHz, Frequency: 5800 MHz; Duty Cycle: 1:1

Medium: MSL 5000 MHz

Medium parameters used: $f = 5200$ MHz; $\sigma = 5.37$ mho/m; $\epsilon_r = 47.2$; $\rho = 1000$ kg/m³, Medium

parameters used: $f = 5500$ MHz; $\sigma = 5.75$ mho/m; $\epsilon_r = 46.6$; $\rho = 1000$ kg/m³, Medium parameters used: $f = 5800$ MHz; $\sigma = 6.16$ mho/m; $\epsilon_r = 46.2$; $\rho = 1000$ kg/m³

Phantom section: Flat Section

Measurement Standard: DASY5 (IEEE/IEC/ANSI C63.19-2007)

DASY5 Configuration:

- Probe: EX3DV4 - SN3503; ConvF(4.88, 4.88, 4.88), ConvF(4.37, 4.37, 4.37), ConvF(4.57, 4.57, 4.57); Calibrated: 05.03.2010
- Sensor-Surface: 2mm (Mechanical Surface Detection)
- Electronics: DAE4 Sn601; Calibrated: 10.06.2010
- Phantom: Flat Phantom 5.0 (back); Type: QD000P50AA; Serial: 1002
- Measurement SW: DASY52, V52.6.1 Build (408)
- Postprocessing SW: SEMCAD X, V14.4.2 Build (2595)

Pin=100mW/d=10mm, f=5200 MHz 2/Zoom Scan (4x4x2mm), dist=2mm (8x8x6)/Cube 0:

Measurement grid: $dx=4$ mm, $dy=4$ mm, $dz=2$ mm

Reference Value = 60.106 V/m; Power Drift = -0.04 dB

Peak SAR (extrapolated) = 30.996 W/kg

SAR(1 g) = 7.83 mW/g; SAR(10 g) = 2.17 mW/g

Maximum value of SAR (measured) = 15.137 mW/g

Pin=100mW/d=10mm, f=5500 MHz/Zoom Scan (4x4x2mm), dist=2mm (8x8x6)/Cube 0:

Measurement grid: $dx=4$ mm, $dy=4$ mm, $dz=2$ mm

Reference Value = 60.894 V/m; Power Drift = -0.04 dB

Peak SAR (extrapolated) = 35.975 W/kg

SAR(1 g) = 8.51 mW/g; SAR(10 g) = 2.34 mW/g

Maximum value of SAR (measured) = 16.704 mW/g

Pin=100mW/d=10mm, f=5800 MHz/Zoom Scan (4x4x2mm), dist=2mm (8x8x6)/Cube 0:

Measurement grid: $dx=4$ mm, $dy=4$ mm, $dz=2$ mm

Reference Value = 56.118 V/m; Power Drift = -0.01 dB

Peak SAR (extrapolated) = 33.913 W/kg

SAR(1 g) = 7.56 mW/g; SAR(10 g) = 2.07 mW/g

Maximum value of SAR (measured) = 15.043 mW/g

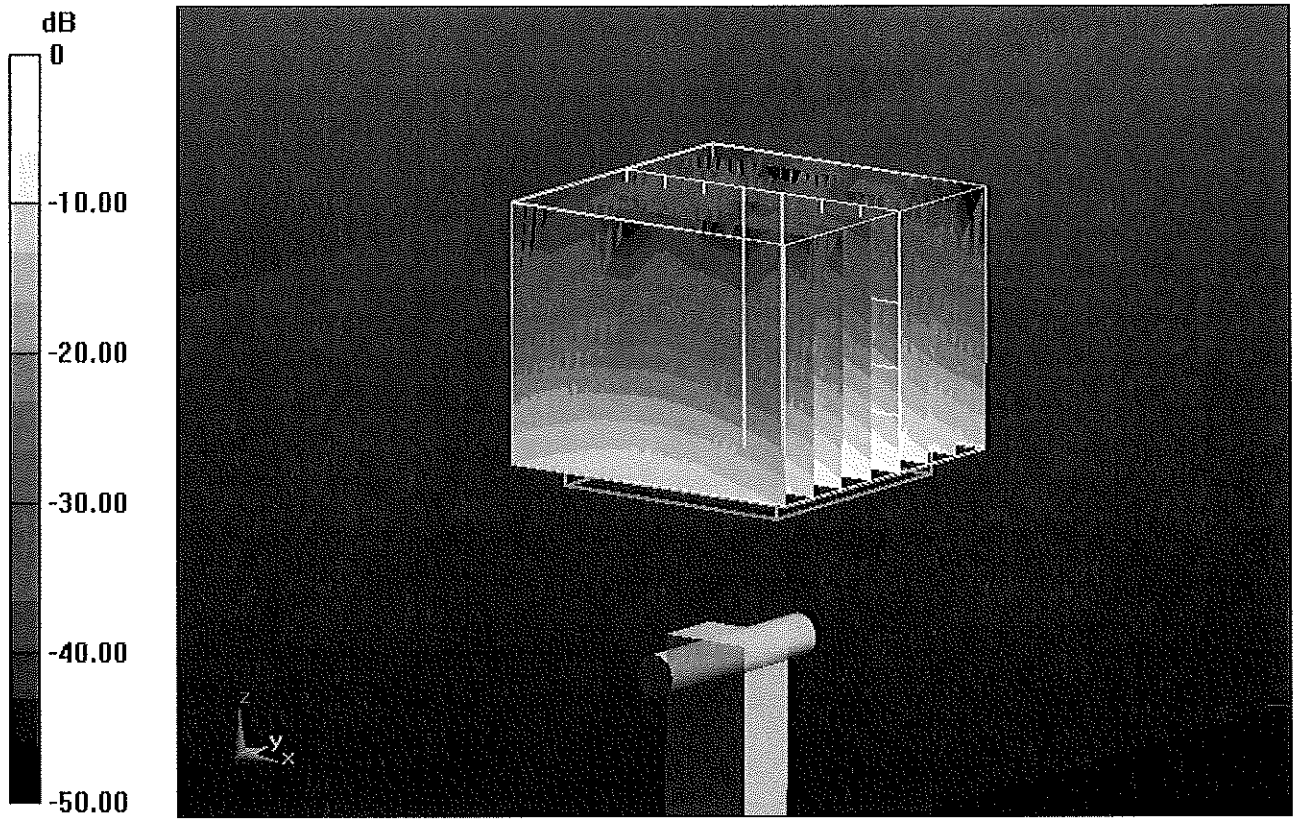

0 dB = 15.040mW/g

Impedance Measurement Plot for Body TSL

10 Feb 2011 10:41:51

[CH1] S11 1 U FS 3: 50.912 Ω -6.5547 Ω 4.6694 pF 5 200.000 000 MHz

*
Del
Cor
Avg
16
↑

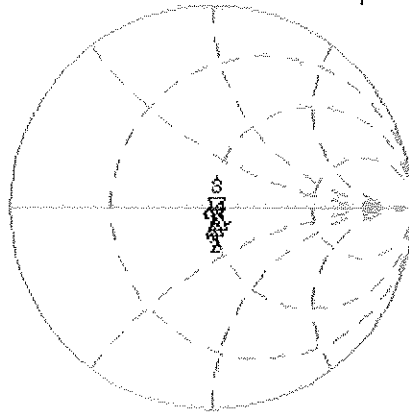

CH1 Markers

1: 51.996 Ω
-1.0859 Ω
5.80000 GHz
2: 50.543 Ω
-3.8574 Ω
5.50000 GHz

CH2 S11 LOG 5 dB/REF -20 dB 3:-23.678 dB 5 200.000 000 MHz

Cor
Avg
16
↑

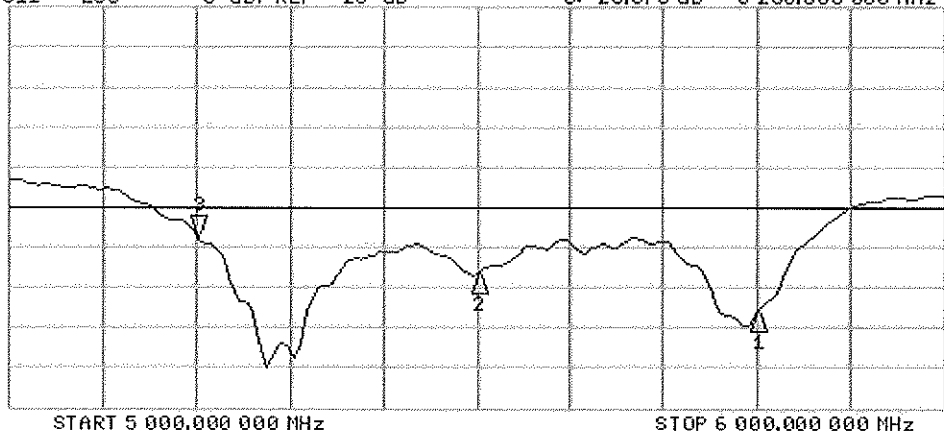

CH2 Markers

1:-33.031 dB
5.80000 GHz
2:-28.232 dB
5.50000 GHz



Accredited by the Swiss Accreditation Service (SAS)
The Swiss Accreditation Service is one of the signatories to the EA
Multilateral Agreement for the recognition of calibration certificates

Accreditation No.: **SCS 108**

Client **PC Test**

Certificate No: **EX-3550_Feb11**

CALIBRATION CERTIFICATE

Object: **EX3DV4 - SN:3550**

Calibration procedure(s): **QA CAL-01.v7, QA CAL-14.v3, QA CAL-23.v4, QA CAL-25.v3
Calibration procedure for dosimetric E-field probes**

Calibration date: **February 14, 2011**

This calibration certificate documents the traceability to national standards, which realize the physical units of measurements (SI).
The measurements and the uncertainties with confidence probability are given on the following pages and are part of the certificate.

All calibrations have been conducted in the closed laboratory facility: environment temperature (22 ± 3)°C and humidity < 70%.

Calibration Equipment used (M&TE critical for calibration)

✓
KOK
2/22/11

Primary Standards	ID	Cal Date (Certificate No.)	Scheduled Calibration
Power meter E4419B	GB41293874	01-Apr-10 (No. 217-01136)	Apr-11
Power sensor E4412A	MY41495277	01-Apr-10 (No. 217-01136)	Apr-11
Power sensor E4412A	MY41498087	01-Apr-10 (No. 217-01136)	Apr-11
Reference 3 dB Attenuator	SN: S5054 (3c)	30-Mar-10 (No. 217-01159)	Mar-11
Reference 20 dB Attenuator	SN: S5086 (20b)	30-Mar-10 (No. 217-01161)	Mar-11
Reference 30 dB Attenuator	SN: S5129 (30b)	30-Mar-10 (No. 217-01160)	Mar-11
Reference Probe ES3DV2	SN: 3013	29-Dec-10 (No. ES3-3013_Dec10)	Dec-11
DAE4	SN: 654	23-Apr-10 (No. DAE4-654_Apr10)	Apr-11
Secondary Standards	ID	Check Date (in house)	Scheduled Check
RF generator HP 8648C	US3642U01700	4-Aug-99 (in house check Oct-09)	In house check: Oct-11
Network Analyzer HP 8753E	US37390585	18-Oct-01 (in house check Oct-10)	In house check: Oct-11

	Name	Function	Signature
Calibrated by:	Katja Pokovic	Technical Manager	
Approved by:	Niels Kuster	Quality Manager	

Issued: February 14, 2011

This calibration certificate shall not be reproduced except in full without written approval of the laboratory.



Accredited by the Swiss Accreditation Service (SAS)

Accreditation No.: **SCS 108**

The Swiss Accreditation Service is one of the signatories to the EA Multilateral Agreement for the recognition of calibration certificates

Glossary:

TSL	tissue simulating liquid
NORM _{x,y,z}	sensitivity in free space
ConvF	sensitivity in TSL / NORM _{x,y,z}
DCP	diode compression point
CF	crest factor (1/duty_cycle) of the RF signal
A, B, C	modulation dependent linearization parameters
Polarization \varnothing	\varnothing rotation around probe axis
Polarization ϑ	ϑ rotation around an axis that is in the plane normal to probe axis (at measurement center), i.e., $\vartheta = 0$ is normal to probe axis

Calibration is Performed According to the Following Standards:

- IEEE Std 1528-2003, "IEEE Recommended Practice for Determining the Peak Spatial-Averaged Specific Absorption Rate (SAR) in the Human Head from Wireless Communications Devices: Measurement Techniques", December 2003
- IEC 62209-1, "Procedure to measure the Specific Absorption Rate (SAR) for hand-held devices used in close proximity to the ear (frequency range of 300 MHz to 3 GHz)", February 2005

Methods Applied and Interpretation of Parameters:

- NORM_{x,y,z}**: Assessed for E-field polarization $\vartheta = 0$ ($f \leq 900$ MHz in TEM-cell; $f > 1800$ MHz: R22 waveguide). NORM_{x,y,z} are only intermediate values, i.e., the uncertainties of NORM_{x,y,z} does not affect the E²-field uncertainty inside TSL (see below ConvF).
- NORM(f)_{x,y,z}** = NORM_{x,y,z} * frequency_response (see Frequency Response Chart). This linearization is implemented in DASY4 software versions later than 4.2. The uncertainty of the frequency response is included in the stated uncertainty of ConvF.
- DCP_{x,y,z}**: DCP are numerical linearization parameters assessed based on the data of power sweep with CW signal (no uncertainty required). DCP does not depend on frequency nor media.
- PAR**: PAR is the Peak to Average Ratio that is not calibrated but determined based on the signal characteristics
- A_{x,y,z}; B_{x,y,z}; C_{x,y,z}** are numerical linearization parameters in dB assessed based on the data of power sweep for specific modulation signal. The parameters do not depend on frequency nor media.
- VR**: VR is the validity range of the calibration related to the average diode voltage or DAE voltage in mV.
- ConvF and Boundary Effect Parameters**: Assessed in flat phantom using E-field (or Temperature Transfer Standard for $f \leq 800$ MHz) and inside waveguide using analytical field distributions based on power measurements for $f > 800$ MHz. The same setups are used for assessment of the parameters applied for boundary compensation (alpha, depth) of which typical uncertainty values are given. These parameters are used in DASY4 software to improve probe accuracy close to the boundary. The sensitivity in TSL corresponds to NORM_{x,y,z} * ConvF whereby the uncertainty corresponds to that given for ConvF. A frequency dependent ConvF is used in DASY version 4.4 and higher which allows extending the validity from ± 50 MHz to ± 100 MHz.
- Spherical isotropy (3D deviation from isotropy)**: in a field of low gradients realized using a flat phantom exposed by a patch antenna.
- Sensor Offset**: The sensor offset corresponds to the offset of virtual measurement center from the probe tip (on probe axis). No tolerance required.

Probe EX3DV4

SN:3550

Manufactured: May 19, 2004
Calibrated: February 14, 2011

Calibrated for DASY/EASY Systems
(Note: non-compatible with DASY2 system!)

DASY/EASY - Parameters of Probe: EX3DV4 - SN:3550

Basic Calibration Parameters

	Sensor X	Sensor Y	Sensor Z	Unc (k=2)
Norm ($\mu\text{V}/(\text{V}/\text{m})^2$) ^A	0.52	0.45	0.50	$\pm 10.1 \%$
DCP (mV) ^B	100.3	98.8	99.0	

Modulation Calibration Parameters

UID	Communication System Name	PAR		A dB	B dB	C dB	VR mV	Unc ^E (k=2)
10000	CW	0.00	X	0.00	0.00	1.00	110.7	$\pm 2.2 \%$
			Y	0.00	0.00	1.00	145.7	
			Z	0.00	0.00	1.00	148.8	

The reported uncertainty of measurement is stated as the standard uncertainty of measurement multiplied by the coverage factor $k=2$, which for a normal distribution corresponds to a coverage probability of approximately 95%.

^A The uncertainties of NormX,Y,Z do not affect the E^2 -field uncertainty inside TSL (see Pages 5 and 6).

^B Numerical linearization parameter: uncertainty not required.

^E Uncertainty is determined using the max. deviation from linear response applying rectangular distribution and is expressed for the square of the field value.

DASY/EASY - Parameters of Probe: EX3DV4 - SN:3550

Calibration Parameter Determined in Head Tissue Simulating Media

f (MHz) ^C	Relative Permittivity ^F	Conductivity (S/m) ^F	ConvF X	ConvF Y	ConvF Z	Alpha	Depth (mm)	Unct. (k=2)
750	41.9	0.89	8.42	8.42	8.42	0.48	0.69	± 12.0 %
835	41.5	0.90	8.04	8.04	8.04	0.33	0.84	± 12.0 %
1750	40.1	1.37	7.33	7.33	7.33	0.46	0.65	± 12.0 %
1900	40.0	1.40	7.01	7.01	7.01	0.42	0.72	± 12.0 %
2450	39.2	1.80	6.29	6.29	6.29	0.13	1.57	± 12.0 %
2600	39.0	1.96	6.13	6.13	6.13	0.20	1.32	± 12.0 %
4950	36.3	4.40	4.37	4.37	4.37	0.35	1.80	± 13.1 %
5200	36.0	4.66	4.06	4.06	4.06	0.35	1.80	± 13.1 %
5300	35.9	4.76	3.92	3.92	3.92	0.35	1.80	± 13.1 %
5500	35.6	4.96	3.77	3.77	3.77	0.35	1.80	± 13.1 %
5600	35.5	5.07	3.50	3.50	3.50	0.40	1.80	± 13.1 %
5800	35.3	5.27	3.64	3.64	3.64	0.40	1.80	± 13.1 %

^C Frequency validity of ± 100 MHz only applies for DASY v4.4 and higher (see Page 2), else it is restricted to ± 50 MHz. The uncertainty is the RSS of the ConvF uncertainty at calibration frequency and the uncertainty for the indicated frequency band.

^F At frequencies below 3 GHz, the validity of tissue parameters (ϵ and σ) can be relaxed to ± 10% if liquid compensation formula is applied to measured SAR values. At frequencies above 3 GHz, the validity of tissue parameters (ϵ and σ) is restricted to ± 5%. The uncertainty is the RSS of the ConvF uncertainty for indicated target tissue parameters.

DASY/EASY - Parameters of Probe: EX3DV4- SN:3550

Calibration Parameter Determined in Body Tissue Simulating Media

f (MHz) ^C	Relative Permittivity ^F	Conductivity (S/m) ^F	ConvF X	ConvF Y	ConvF Z	Alpha	Depth (mm)	Unct. (k=2)
750	55.5	0.96	8.18	8.18	8.18	0.23	1.09	± 12.0 %
835	55.2	0.97	8.11	8.11	8.11	0.25	1.05	± 12.0 %
1750	53.4	1.49	7.21	7.21	7.21	0.42	0.89	± 12.0 %
1900	53.3	1.52	6.77	6.77	6.77	0.35	0.84	± 12.0 %
2450	52.7	1.95	6.25	6.25	6.25	0.30	0.86	± 12.0 %
2600	52.5	2.16	5.98	5.98	5.98	0.21	1.03	± 12.0 %
3700	51.0	3.55	5.42	5.42	5.42	0.20	1.95	± 13.1 %
4950	49.4	5.01	3.72	3.72	3.72	0.45	1.90	± 13.1 %
5200	49.0	5.30	3.58	3.58	3.58	0.45	1.90	± 13.1 %
5300	48.9	5.42	3.31	3.31	3.31	0.48	1.90	± 13.1 %
5500	48.6	5.65	3.21	3.21	3.21	0.47	1.90	± 13.1 %
5600	48.5	5.77	3.19	3.19	3.19	0.45	1.90	± 13.1 %
5800	48.2	6.00	3.29	3.29	3.29	0.50	1.90	± 13.1 %

^C Frequency validity of ± 100 MHz only applies for DASY v4.4 and higher (see Page 2), else it is restricted to ± 50 MHz. The uncertainty is the RSS of the ConvF uncertainty at calibration frequency and the uncertainty for the indicated frequency band.

^F At frequencies below 3 GHz, the validity of tissue parameters (ϵ and σ) can be relaxed to ± 10% if liquid compensation formula is applied to measured SAR values. At frequencies above 3 GHz, the validity of tissue parameters (ϵ and σ) is restricted to ± 5%. The uncertainty is the RSS of the ConvF uncertainty for indicated target tissue parameters.

Frequency Response of E-Field

(TEM-Cell:ifi110 EXX, Waveguide: R22)

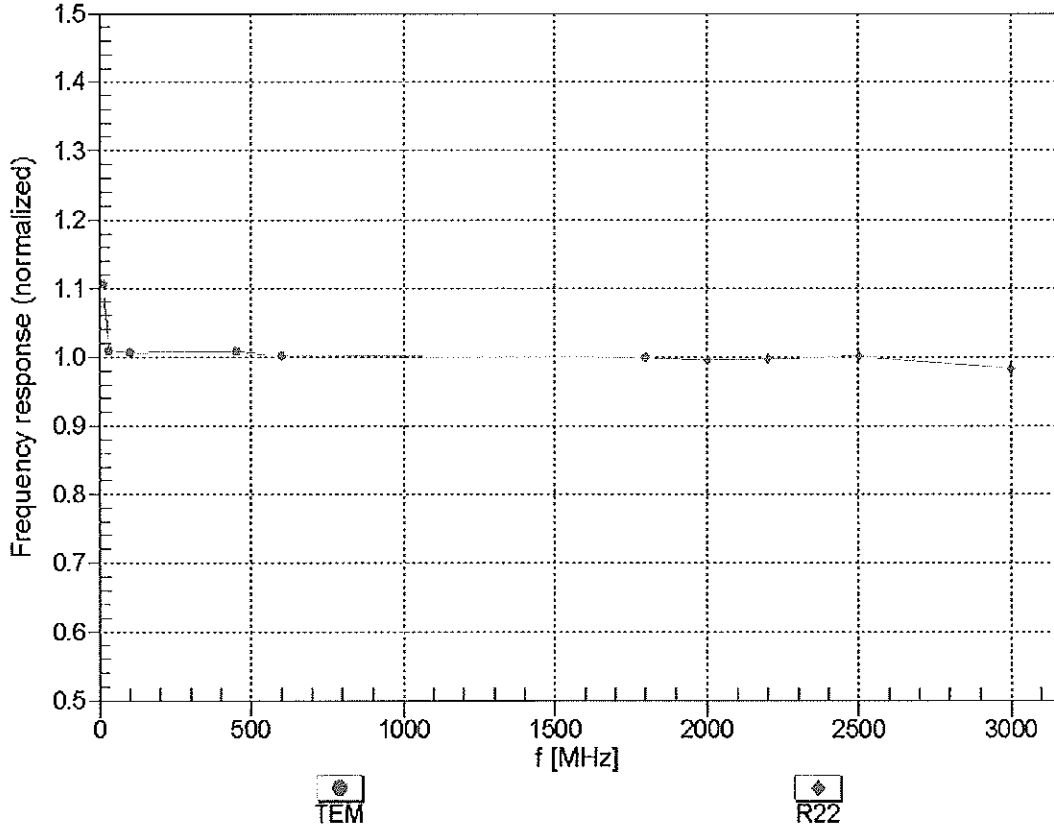

Uncertainty of Frequency Response of E-field: $\pm 6.3\%$ (k=2)

Receiving Pattern (ϕ), $\theta = 0^\circ$

f=600 MHz,TEM

f=1800 MHz,R22

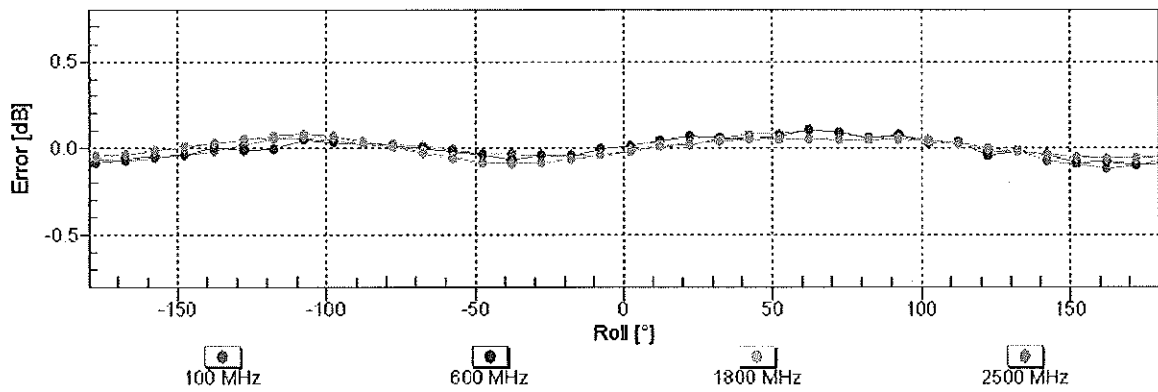
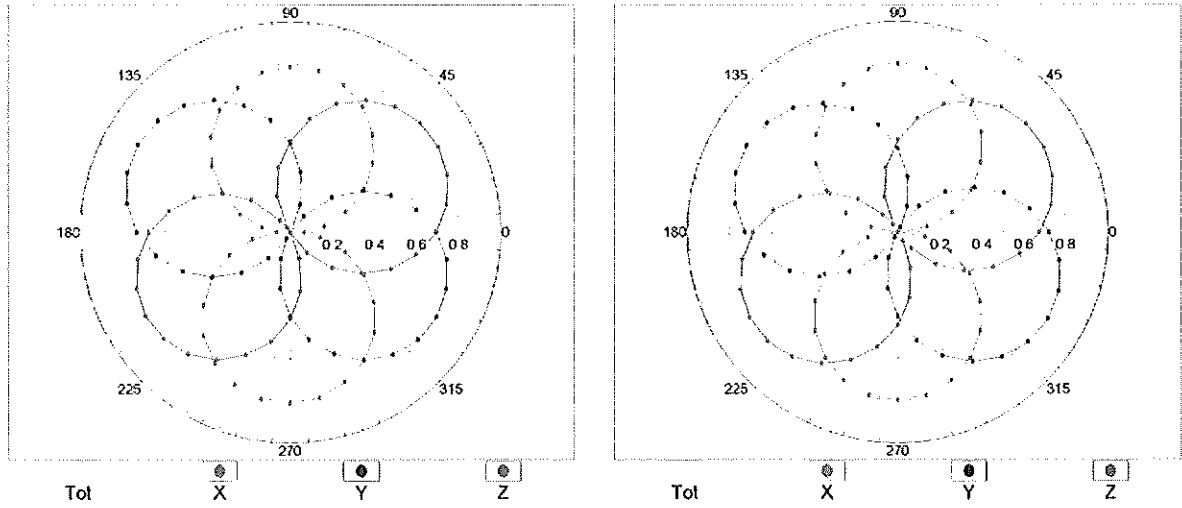

Uncertainty of Axial Isotropy Assessment: $\pm 0.5\%$ ($k=2$)

Dynamic Range $f(\text{SAR}_{\text{head}})$ (TEM cell , $f = 900 \text{ MHz}$)

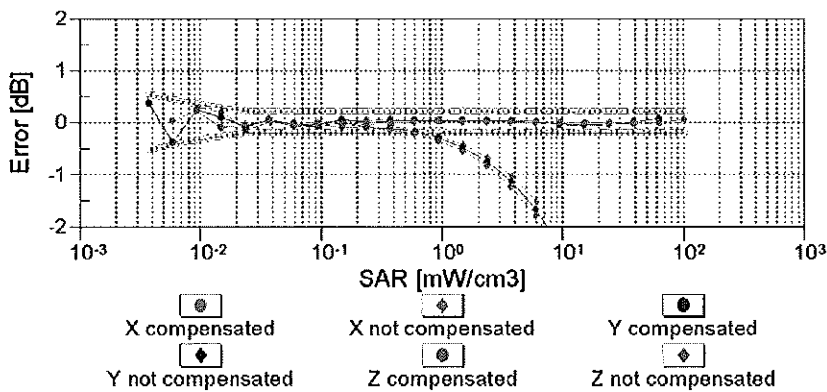
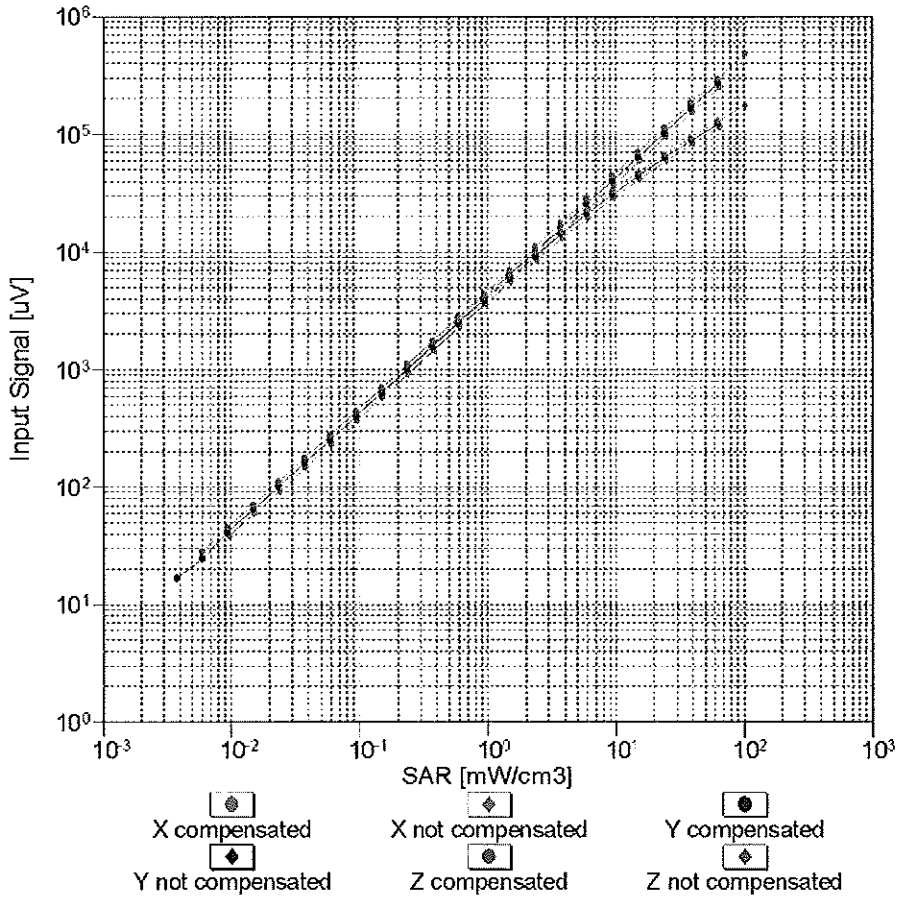

Uncertainty of Linearity Assessment: $\pm 0.6\%$ ($k=2$)

Conversion Factor Assessment

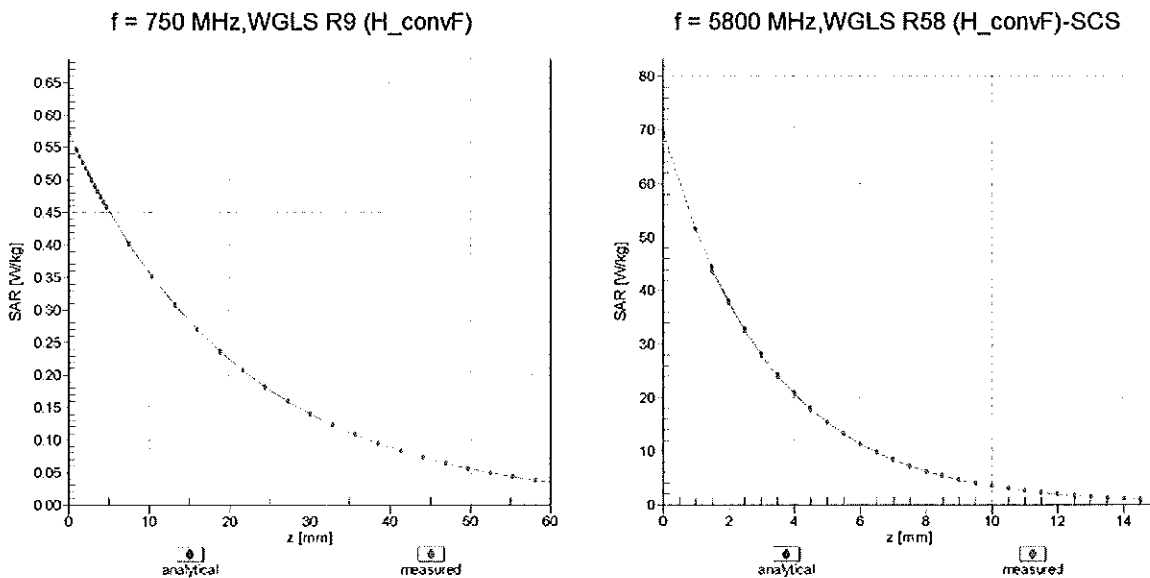

Deviation from Isotropy in Air Error (ϕ, ϑ), f = 900 MHz

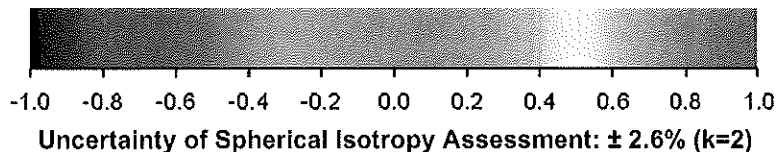
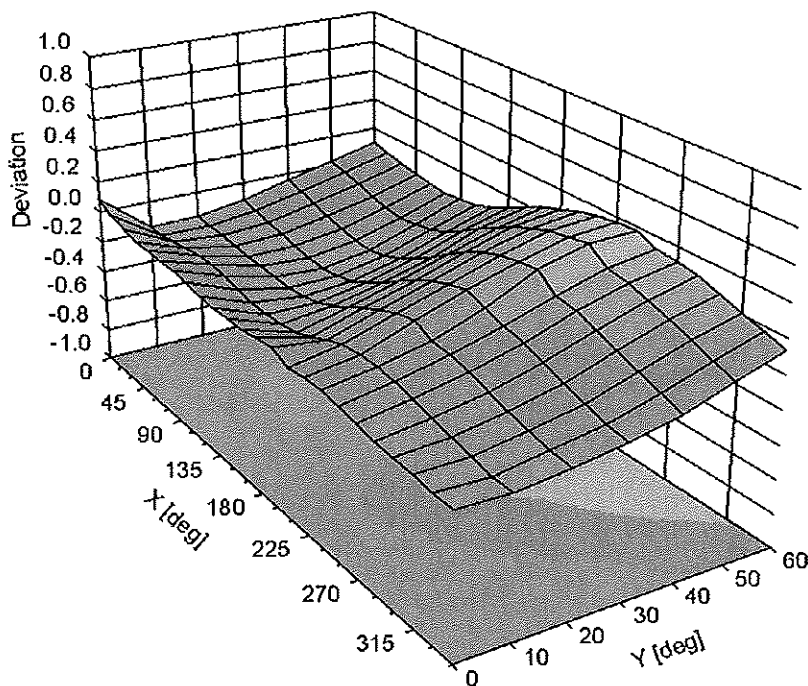

DASY/EASY - Parameters of Probe: EX3DV4 - SN:3550

Other Probe Parameters

Sensor Arrangement	Triangular
Connector Angle (°)	Not applicable
Mechanical Surface Detection Mode	enabled
Optical Surface Detection Mode	disabled
Probe Overall Length	337 mm
Probe Body Diameter	10 mm
Tip Length	9 mm
Tip Diameter	3 mm
Probe Tip to Sensor X Calibration Point	1 mm
Probe Tip to Sensor Y Calibration Point	1 mm
Probe Tip to Sensor Z Calibration Point	1 mm
Recommended Measurement Distance from Surface	2 mm



Accredited by the Swiss Accreditation Service (SAS)
The Swiss Accreditation Service is one of the signatories to the EA
Multilateral Agreement for the recognition of calibration certificates

Accreditation No.: SCS 108

Client **PC Test**

Certificate No: **EX3-3561_Aug10**

CALIBRATION CERTIFICATE

Object **EX3DV4 - SN:3561**

Calibration procedure(s) **QA CAL-01.v6, QA CAL-14.v3, QA CAL-23.v3 and QA CAL-25.v2
Calibration procedure for dosimetric E-field probes**

Calibration date: **August 19, 2010**

*KOK
8/30/10*

This calibration certificate documents the traceability to national standards, which realize the physical units of measurements (SI).
The measurements and the uncertainties with confidence probability are given on the following pages and are part of the certificate.

All calibrations have been conducted in the closed laboratory facility: environment temperature (22 ± 3)°C and humidity < 70%.

Calibration Equipment used (M&TE critical for calibration)

Primary Standards	ID #	Cal Date (Certificate No.)	Scheduled Calibration
Power meter E4419B	GB41293874	1-Apr-10 (No. 217-01136)	Apr-11
Power sensor E4412A	MY41495277	1-Apr-10 (No. 217-01136)	Apr-11
Power sensor E4412A	MY41498087	1-Apr-10 (No. 217-01136)	Apr-11
Reference 3 dB Attenuator	SN: S5054 (3c)	30-Mar-10 (No. 217-01159)	Mar-11
Reference 20 dB Attenuator	SN: S5086 (20b)	30-Mar-10 (No. 217-01161)	Mar-11
Reference 30 dB Attenuator	SN: S5129 (30b)	30-Mar-10 (No. 217-01160)	Mar-11
Reference Probe ES3DV2	SN: 3013	30-Dec-09 (No. ES3-3013_Dec09)	Dec-10
DAE4	SN: 660	20-Apr-10 (No. DAE4-660_Apr10)	Apr-11

Secondary Standards	ID #	Check Date (in house)	Scheduled Check
RF generator HP 8648C	US3642U01700	4-Aug-99 (in house check Oct-09)	In house check: Oct-11
Network Analyzer HP 8753E	US37390585	18-Oct-01 (in house check Oct-09)	In house check: Oct10

	Name	Function	Signature
Calibrated by:	Katja Pokovic	Technical Manager	
Approved by:	Niels Kuster	Quality Manager	

Issued: August 20, 2010

This calibration certificate shall not be reproduced except in full without written approval of the laboratory.



Accredited by the Swiss Accreditation Service (SAS)
The Swiss Accreditation Service is one of the signatories to the EA
Multilateral Agreement for the recognition of calibration certificates

Accreditation No.: **SCS 108**

Glossary:

TSL	tissue simulating liquid
NORM _{x,y,z}	sensitivity in free space
ConvF	sensitivity in TSL / NORM _{x,y,z}
DCP	diode compression point
CF	crest factor (1/duty_cycle) of the RF signal
A, B, C	modulation dependent linearization parameters
Polarization φ	φ rotation around probe axis
Polarization ϑ	ϑ rotation around an axis that is in the plane normal to probe axis (at measurement center), i.e., $\vartheta = 0$ is normal to probe axis

Calibration is Performed According to the Following Standards:

- IEEE Std 1528-2003, "IEEE Recommended Practice for Determining the Peak Spatial-Averaged Specific Absorption Rate (SAR) in the Human Head from Wireless Communications Devices: Measurement Techniques", December 2003
- IEC 62209-1, "Procedure to measure the Specific Absorption Rate (SAR) for hand-held devices used in close proximity to the ear (frequency range of 300 MHz to 3 GHz)", February 2005

Methods Applied and Interpretation of Parameters:

- NORM_{x,y,z}**: Assessed for E-field polarization $\vartheta = 0$ ($f \leq 900$ MHz in TEM-cell; $f > 1800$ MHz: R22 waveguide). NORM_{x,y,z} are only intermediate values, i.e., the uncertainties of NORM_{x,y,z} does not effect the E²-field uncertainty inside TSL (see below ConvF).
- NORM(f)_{x,y,z} = NORM_{x,y,z} * frequency_response** (see Frequency Response Chart). This linearization is implemented in DASY4 software versions later than 4.2. The uncertainty of the frequency response is included in the stated uncertainty of ConvF.
- DCP_{x,y,z}**: DCP are numerical linearization parameters assessed based on the data of power sweep with CW signal (no uncertainty required). DCP does not depend on frequency nor media.
- A_{x,y,z}; B_{x,y,z}; C_{x,y,z}; VR_{x,y,z}; A, B, C** are numerical linearization parameters assessed based on the data of power sweep for specific modulation signal. The parameters do not depend on frequency nor media. VR is the maximum calibration range expressed in RMS voltage across the diode.
- ConvF and Boundary Effect Parameters**: Assessed in flat phantom using E-field (or Temperature Transfer Standard for $f \leq 800$ MHz) and inside waveguide using analytical field distributions based on power measurements for $f > 800$ MHz. The same setups are used for assessment of the parameters applied for boundary compensation (alpha, depth) of which typical uncertainty values are given. These parameters are used in DASY4 software to improve probe accuracy close to the boundary. The sensitivity in TSL corresponds to NORM_{x,y,z} * ConvF whereby the uncertainty corresponds to that given for ConvF. A frequency dependent ConvF is used in DASY version 4.4 and higher which allows extending the validity from ± 50 MHz to ± 100 MHz.
- Spherical isotropy (3D deviation from isotropy)**: in a field of low gradients realized using a flat phantom exposed by a patch antenna.
- Sensor Offset**: The sensor offset corresponds to the offset of virtual measurement center from the probe tip (on probe axis). No tolerance required.

Probe EX3DV4

SN:3561

Manufactured:	February 14, 2005
Last calibrated:	August 26, 2008
Recalibrated:	August 19, 2010

Calibrated for DASY/EASY Systems

(Note: non-compatible with DASY2 system!)

DASY/EASY - Parameters of Probe: EX3DV4 SN:3561**Basic Calibration Parameters**

	Sensor X	Sensor Y	Sensor Z	Unc (k=2)
Norm ($\mu\text{V}/(\text{V}/\text{m})^2$) ^A	0.45	0.48	0.43	$\pm 10.1\%$
DCP (mV) ^B	87.4	89.6	88.5	

Modulation Calibration Parameters

UID	Communication System Name	PAR		A dB	B dBuV	C	VR mV	Unc ^E (k=2)
10000	CW	0.00	X	0.00	0.00	1.00	300	$\pm 1.5\%$
			Y	0.00	0.00	1.00	300	
			Z	0.00	0.00	1.00	300	

The reported uncertainty of measurement is stated as the standard uncertainty of measurement multiplied by the coverage factor $k=2$, which for a normal distribution corresponds to a coverage probability of approximately 95%.

^A The uncertainties of NormX,Y,Z do not affect the \hat{E} field uncertainty inside TSL (see Pages 5 and 6).

^B Numerical linearization parameter: uncertainty not required.

^E Uncertainty is determined using the maximum deviation from linear response applying rectangular distribution and is expressed for the square of the field value

DASY/EASY - Parameters of Probe: EX3DV4 SN:3561

Calibration Parameter Determined in Head Tissue Simulating Media

f [MHz]	Validity [MHz] ^f	Permittivity	Conductivity	ConvF X	ConvF Y	ConvF Z	Alpha	Depth Unc (k=2)
750	± 50 / ± 100	41.9 ± 5%	0.89 ± 5%	8.36	8.36	8.36	0.76	0.64 ± 11.0%
835	± 50 / ± 100	41.5 ± 5%	0.90 ± 5%	7.96	7.96	7.96	0.75	0.64 ± 11.0%
1750	± 50 / ± 100	40.1 ± 5%	1.37 ± 5%	6.92	6.92	6.92	0.90	0.57 ± 11.0%
1900	± 50 / ± 100	40.0 ± 5%	1.40 ± 5%	6.69	6.69	6.69	0.76	0.63 ± 11.0%
2450	± 50 / ± 100	39.2 ± 5%	1.80 ± 5%	6.11	6.11	6.11	0.42	0.83 ± 11.0%
2600	± 50 / ± 100	39.0 ± 5%	1.96 ± 5%	6.09	6.09	6.09	0.36	0.93 ± 11.0%

^c The validity of ± 100 MHz only applies for DASY v4.4 and higher (see Page 2). The uncertainty is the RSS of the ConvF uncertainty at calibration frequency and the uncertainty for the indicated frequency band.

DASY/EASY - Parameters of Probe: EX3DV4 SN:3561

Calibration Parameter Determined in Body Tissue Simulating Media

f [MHz]	Validity [MHz] ^c	Permittivity	Conductivity	ConvF X	ConvF Y	ConvF Z	Alpha	Depth Unc (k=2)
835	± 50 / ± 100	55.2 ± 5%	0.97 ± 5%	8.09	8.09	8.09	0.74	0.65 ± 11.0%
1750	± 50 / ± 100	53.4 ± 5%	1.49 ± 5%	6.84	6.84	6.84	0.43	0.82 ± 11.0%
1900	± 50 / ± 100	53.3 ± 5%	1.52 ± 5%	6.59	6.59	6.59	0.56	0.71 ± 11.0%
2450	± 50 / ± 100	52.7 ± 5%	1.95 ± 5%	6.44	6.44	6.44	0.37	0.87 ± 11.0%
2600	± 50 / ± 100	52.5 ± 5%	2.16 ± 5%	6.45	6.45	6.45	0.37	0.95 ± 11.0%
4950	± 50 / ± 100	49.4 ± 5%	5.01 ± 5%	3.80	3.80	3.80	0.53	1.90 ± 13.1%
5200	± 50 / ± 100	49.0 ± 5%	5.30 ± 5%	3.67	3.67	3.67	0.60	1.95 ± 13.1%
5300	± 50 / ± 100	48.5 ± 5%	5.42 ± 5%	3.42	3.42	3.42	0.63	1.95 ± 13.1%
5500	± 50 / ± 100	48.6 ± 5%	5.65 ± 5%	3.31	3.31	3.31	0.63	1.95 ± 13.1%
5600	± 50 / ± 100	48.5 ± 5%	5.77 ± 5%	3.12	3.12	3.12	0.65	1.95 ± 13.1%
5800	± 50 / ± 100	48.2 ± 5%	6.00 ± 5%	3.25	3.25	3.25	0.65	1.95 ± 13.1%

^c The validity of ± 100 MHz only applies for DASY v4.4 and higher (see Page 2). The uncertainty is the RSS of the ConvF uncertainty at calibration frequency and the uncertainty for the indicated frequency band.

Frequency Response of E-Field

(TEM-Cell:ifi110 EXX, Waveguide: R22)

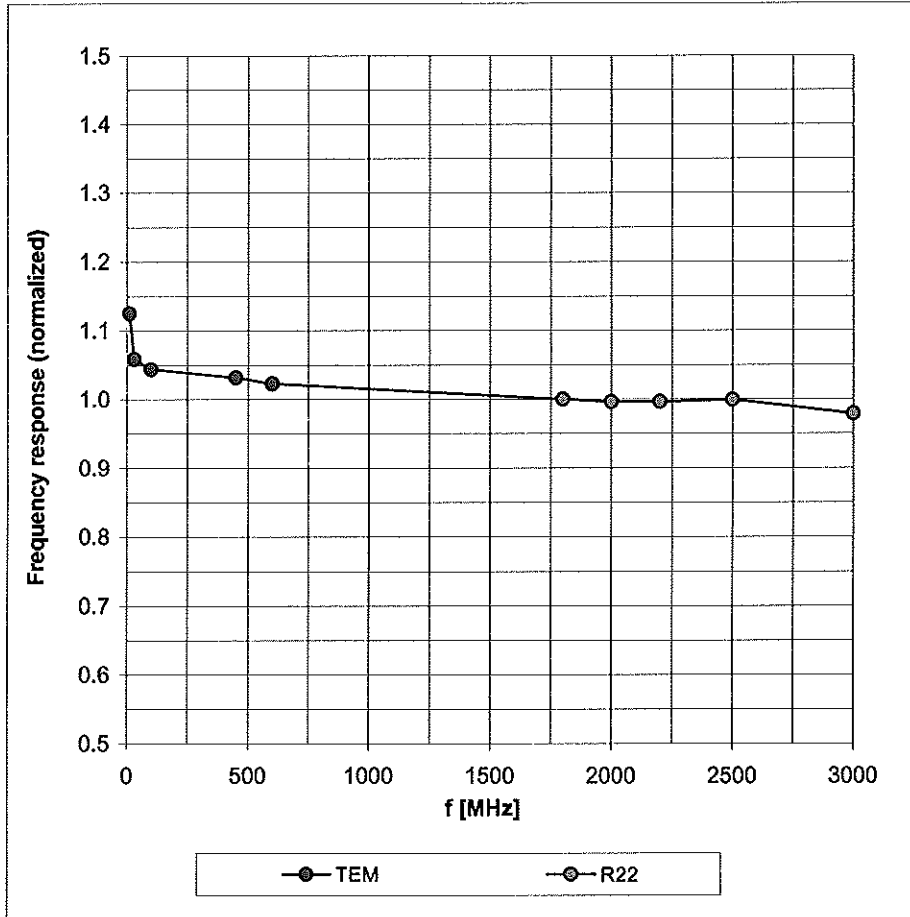

Uncertainty of Frequency Response of E-field: $\pm 6.3\%$ (k=2)

Receiving Pattern (ϕ), $\vartheta = 0^\circ$

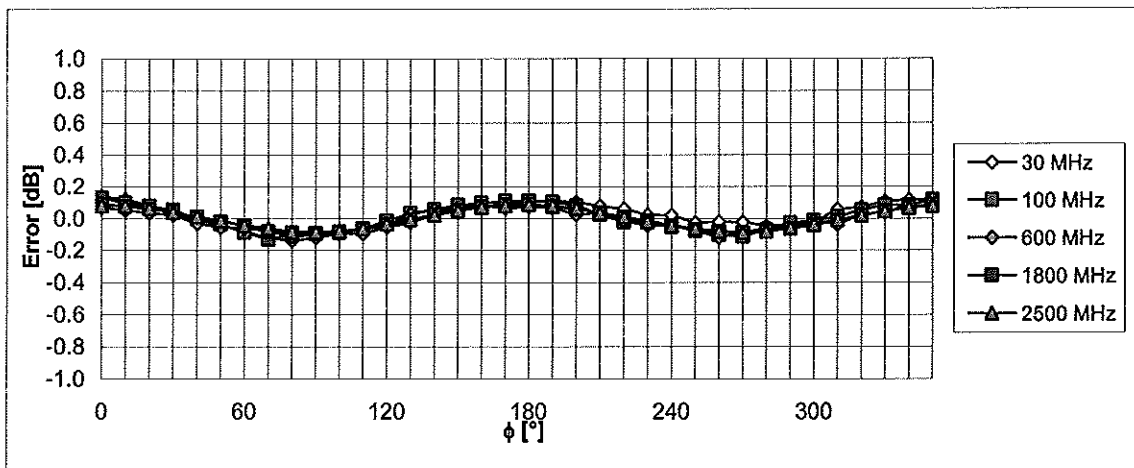
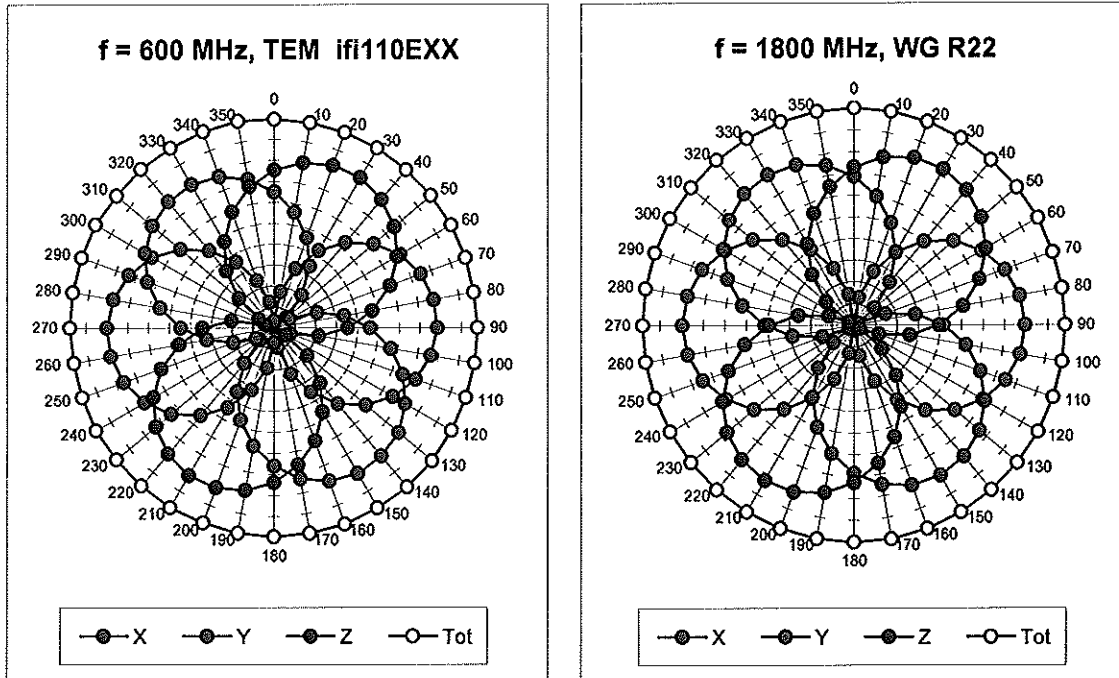

Uncertainty of Axial Isotropy Assessment: $\pm 0.5\%$ (k=2)

Dynamic Range $f(SAR_{head})$ (Waveguide R22, $f = 1800$ MHz)

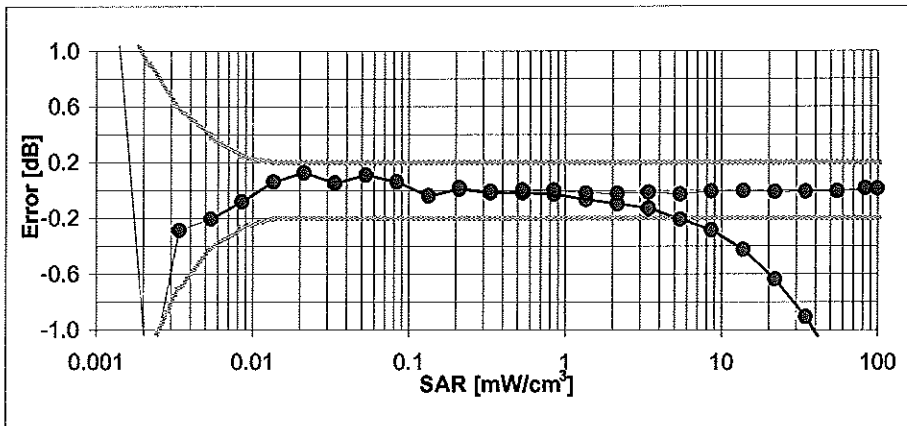
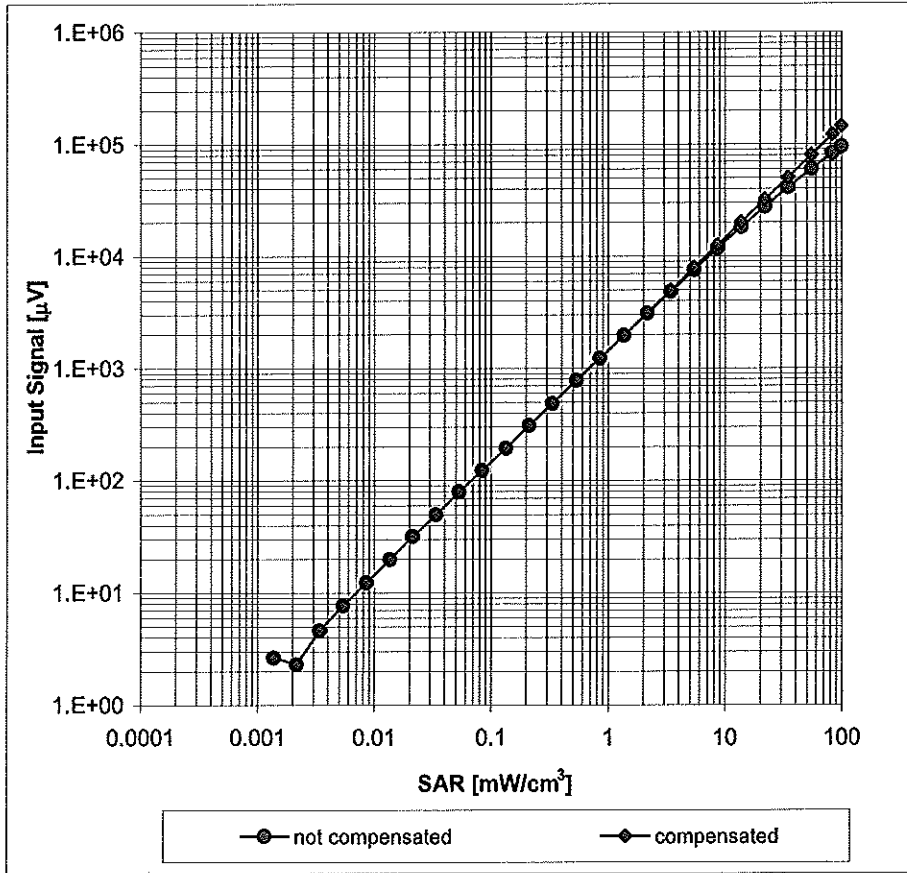

Uncertainty of Linearity Assessment: $\pm 0.6\%$ ($k=2$)

Conversion Factor Assessment

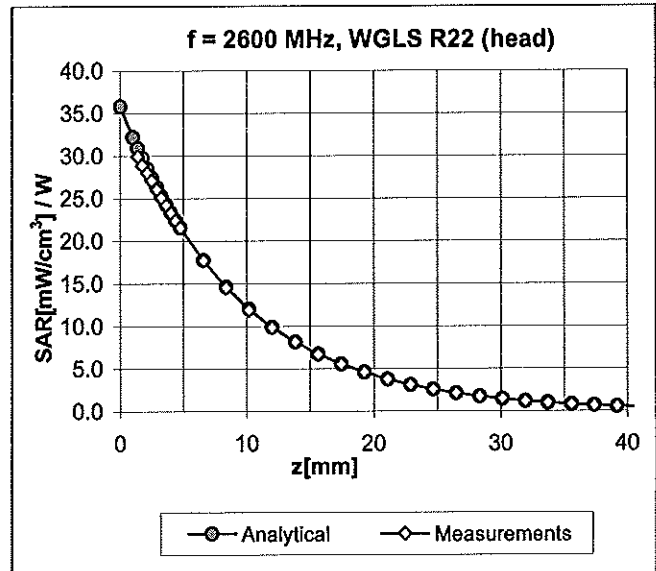
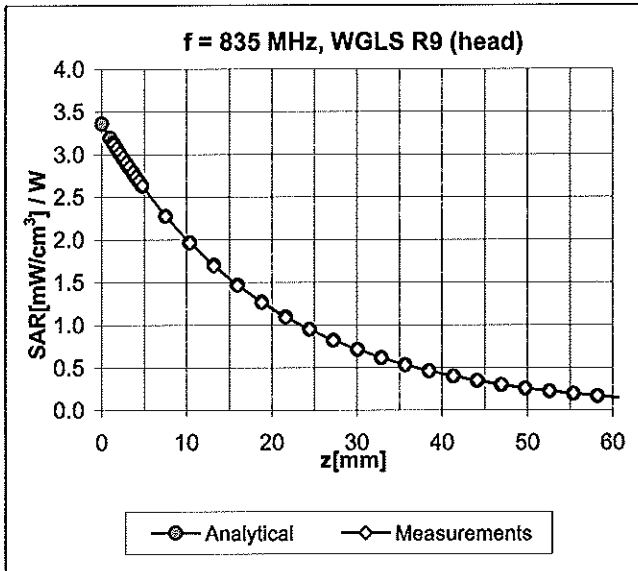

Deviation from Isotropy in HSL

Error (ϕ, θ), f = 900 MHz

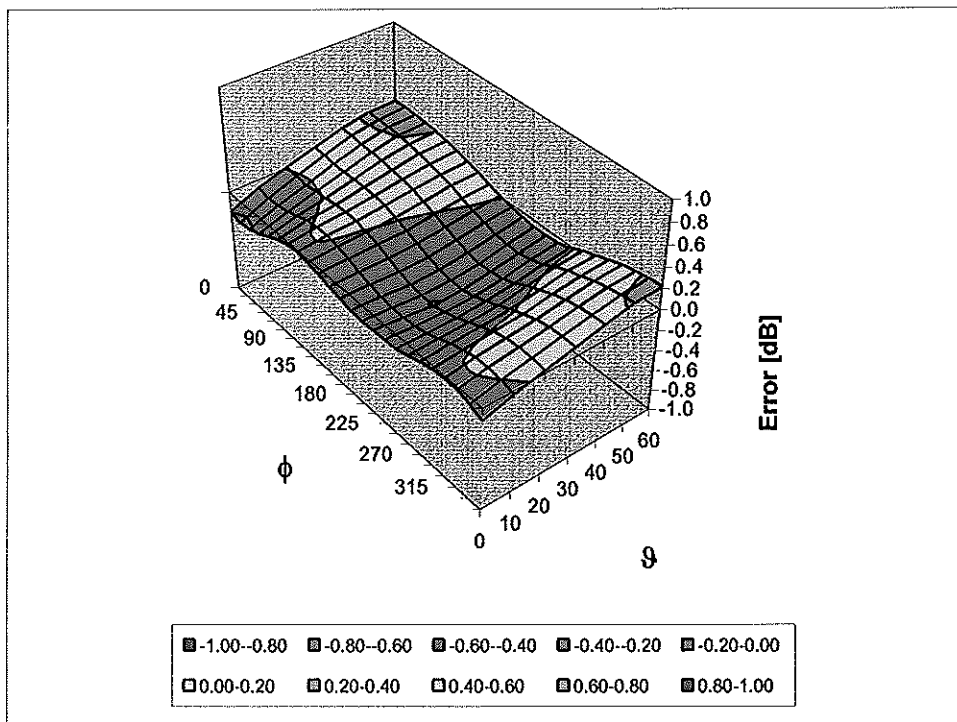

Uncertainty of Spherical Isotropy Assessment: $\pm 2.6\%$ (k=2)

Other Probe Parameters

Sensor Arrangement	Triangular
Connector Angle (°)	Not applicable
Mechanical Surface Detection Mode	enabled
Optical Surface Detection Mode	disabled
Probe Overall Length	337 mm
Probe Body Diameter	10 mm
Tip Length	9 mm
Tip Diameter	2.5 mm
Probe Tip to Sensor X Calibration Point	1 mm
Probe Tip to Sensor Y Calibration Point	1 mm
Probe Tip to Sensor Z Calibration Point	1 mm
Recommended Measurement Distance from Surface	2 mm