



PCTEST ENGINEERING LABORATORY, INC.

6660-B Dobbin Road, Columbia, MD 21045 USA
Tel. 410.290.6652 / Fax 410.290.6554
<http://www.pctestlab.com>



CERTIFICATE OF COMPLIANCE (SAR EVALUATION)

Applicant Name:
Samsung Electronics, Co. Ltd.
18600 Broadwick St.
Rancho Dominguez, CA 90220
United States

Date of Testing:
11/25/08 - 03/02/09
Test Site/Location:
PCTEST Lab, Columbia, MD, USA
Test Report Serial No.:
0810061478.A3L

FCC ID: A3LSWCU200

APPLICANT: SAMSUNG ELECTRONICS, CO. LTD.

EUT Type: WiMAX USB Modem
Application Type: Certification
FCC Rule Part(s): §2.1093; FCC/OET Bulletin 65 Supplement C [July 2001]
FCC Classification: Non-Broadcast Transmitter (TNB)
Model(s): SWC-U200
Tx Frequency: 2496 - 2690 MHz
Conducted Power: 23.8 dBm
Max. SAR Measurement: 1.180 W/kg WiMAX Body SAR
Test Device Serial No.: Pre-Production [S/N: FF-211-A]

This wireless portable device has been shown to be capable of compliance for localized specific absorption rate (SAR) for uncontrolled environment/general population exposure limits specified in ANSI/IEEE Std. C95.1-2005 and has been tested in accordance with the measurement procedures specified in FCC/OET Bulletin 65 Supplement C (2001) and IEEE Std. 1528-2003.

I attest to the accuracy of data. All measurements reported herein were performed by me or were made under my supervision and are correct to the best of my knowledge and belief. I assume full responsibility for the completeness of these measurements and vouch for the qualifications of all persons taking them.

PCTEST certifies that no party to this application has been denied the FCC benefits pursuant to Section 5301 of the Anti-Drug Abuse Act of 1988, 21 U.S.C. 862.

Randy Ortanez
President







FCC ID: A3LSWCU200		CERTIFICATION REPORT		Reviewed by: Quality Manager
SAR Filename: 0810061478.A3L	Test Dates: 11/25/08 - 03/02/09	EUT Type: WiMAX USB Modem		Page 1 of 23

TABLE OF CONTENTS

1	INTRODUCTION	3
2	TEST SITE LOCATION	4
3	SAR MEASUREMENT SETUP	5
4	DASY E-FIELD PROBE SYSTEM	7
5	PROBE CALIBRATION PROCESS	8
6	PHANTOM AND EQUIVALENT TISSUES.....	9
7	DOSIMETRIC ASSESSMENT & PHANTOM SPECS.....	10
8	TEST CONFIGURATION POSITIONS	11
9	BRS/EBS TEST CONFIGURATION	13
10	ANSI/IEEE C95.1-2005 RF EXPOSURE LIMITS.....	16
11	MEASUREMENT UNCERTAINTIES	17
12	SYSTEM VERIFICATION.....	18
13	SAR DATA SUMMARY	19
14	EQUIPMENT LIST.....	20
15	CONCLUSION.....	21
16	REFERENCES	22

FCC ID: A3LSWCU200		CERTIFICATION REPORT		Reviewed by: Quality Manager
SAR Filename: 0810061478.A3L	Test Dates: 11/25/08 - 03/02/09	EUT Type: WiMAX USB Modem	Page 2 of 23	

1 INTRODUCTION

The FCC has adopted the guidelines for evaluating the environmental effects of radio frequency (RF) radiation in ET Docket 93-62 on Aug. 6, 1996 to protect the public and workers from the potential hazards of RF emissions due to FCC-regulated portable devices.[1]

The safety limits used for the environmental evaluation measurements are based on the criteria published by the American National Standards Institute (ANSI) for localized specific absorption rate (SAR) in IEEE/ANSI C95.1-2005 Standard for Safety Levels with Respect to Human Exposure to Radio Frequency Electromagnetic Fields, 3 kHz to 300 GHz[2] and Health Canada RF Exposure Guidelines Safety Code 6 [26]. The measurement procedure described in IEEE/ANSI C95.3-2002 Recommended Practice for the Measurement of Potentially Hazardous Electromagnetic Fields - RF and Microwave [3] is used for guidance in measuring the Specific Absorption Rate (SAR) due to the RF radiation exposure from the Equipment Under Test (EUT). These criteria for SAR evaluation are similar to those recommended by the International Committee for Non-Ionizing Radiation Protection (ICNIRP) in Biological Effects and Exposure Criteria for Radiofrequency Electromagnetic Fields," Report No. Vol 74. SAR is a measure of the rate of energy absorption due to exposure to an RF transmitting source. SAR values have been related to threshold levels for potential biological hazards.

1.1 SAR Definition

Specific Absorption Rate is defined as the time derivative (rate) of the incremental energy (dU) absorbed by (dissipated in) an incremental mass (dm) contained in a volume element (dV) of a given density (ρ). It is also defined as the rate of RF energy absorption per unit mass at a point in an absorbing body (see Fig. 1-1).

$$SAR = \frac{d}{dt} \left(\frac{dU}{dm} \right) = \frac{d}{dt} \left(\frac{dU}{\rho dV} \right)$$

Figure 1-1
SAR Mathematical Equation



SAR is expressed in units of Watts per Kilogram (W/kg).

$$SAR = \frac{\sigma \cdot E^2}{\rho}$$

where:

- σ = conductivity of the tissue-simulating material (S/m)
- ρ = mass density of the tissue-simulating material (kg/m^3)
- E = Total RMS electric field strength (V/m)

NOTE: The primary factors that control rate of energy absorption were found to be the wavelength of the incident field in relation to the dimensions and geometry of the irradiated organism, the orientation of the organism in relation to the polarity of field vectors, the presence of reflecting surfaces, and whether conductive contact is made by the organism with a ground plane.[6]

FCC ID: A3LSWCU200	 PCTEST ENGINEERING LABORATORY, INC.	CERTIFICATION REPORT		Reviewed by: Quality Manager
SAR Filename: 0810061478.A3L	Test Dates: 11/25/08 - 03/02/09	EUT Type: WiMAX USB Modem		Page 3 of 23

3 SAR MEASUREMENT SETUP

3.1 Robotic System

Measurements are performed using the DASY4 automated dosimetric assessment system. The DASY4 is made by Schmid & Partner Engineering AG (SPEAG) in Zurich, Switzerland and consists of high precision robotics system (Staubli), robot controller, Pentium 4 computer, near-field probe, probe alignment sensor, and the generic twin phantom containing the brain equivalent material. The robot is a six-axis industrial robot performing precise movements to position the probe to the location (points) of maximum electromagnetic field (EMF) (see Figure 3-1).

3.2 System Hardware

A cell controller system contains the power supply, robot controller, teach pendant (Joystick), and a remote control used to drive the robot motors. The PC consists of the Gateway Pentium 4 2.53 GHz computer with Windows XP system and SAR Measurement Software DASY4, A/D interface card, monitor, mouse, and keyboard. The Staubli Robot is connected to the cell controller to allow software manipulation of the robot. A data acquisition electronic (DAE) circuit that performs the signal amplification, signal multiplexing, AD-conversion, offset measurements, mechanical surface detection, collision detection, etc. is connected to the Electro-optical coupler (EOC). The EOC performs the conversion from the optical into digital electric signal of the DAE and transfers data to the PC plug-in card.

3.3 System Electronics

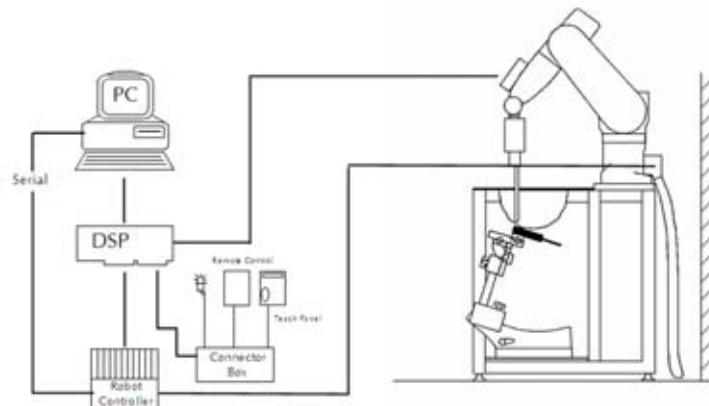



Figure 3-1
SAR Measurement System Setup

The DAE4 consists of a highly sensitive electrometer-grade preamplifier with auto-zeroing, a channel and gain-switching multiplexer, a fast 16 bit AD-converter and a command decoder and control logic unit. Transmission to the PC-card is accomplished through an optical downlink for data and status information and an optical uplink for commands and clock lines. The mechanical probe mounting device includes two different sensor systems for frontal and sidewise probe contacts. They are also used for mechanical surface detection and probe collision detection. The robot uses its own controller with a built in VME-bus computer. The system is described in detail in [7].

FCC ID: A3LSWCU200		CERTIFICATION REPORT		Reviewed by: Quality Manager
SAR Filename: 0810061478.A3L	Test Dates: 11/25/08 - 03/02/09	EUT Type: WiMAX USB Modem		Page 5 of 23

3.4 Automated Test System Specifications

Positioner

Robot: Stäubli Unimation Corp. Robot RX60L
 Repeatability: 0.02 mm
 No. of Axes: 6

Data Acquisition Electronic System (DAE)

Cell Controller

Processor: Pentium 4
 Clock Speed: 2.53 GHz
 Operating System: Windows XP Professional

Data Converter

Features: Signal Amplifier, multiplexer, A/D converter & control logic
 Software: DASY4, SEMCAD software
 Connecting Lines: Optical Downlink for data and status info
 Optical upload for commands and clock

PC Interface Card



Function: 166MHz low power Pentium MMX 32MB chipdisk
 Link to DAE
 16-bit A/D converter for surface detection system
 Two Serial & Ethernet link to robotics
 Direct emergency stop output for robot

Phantom

Type: SAM Twin Phantom (V4.0)
 Shell Material: Composite
 Thickness: 2.0 ± 0.2 mm



**Figure 3-2
 DASY4 SAR Measurement System**

FCC ID: A3LSWCU200		CERTIFICATION REPORT		Reviewed by: Quality Manager
SAR Filename: 0810061478.A3L	Test Dates: 11/25/08 - 03/02/09	EUT Type: WiMAX USB Modem		Page 6 of 23

4.1 Probe Measurement System



Figure 4-1
SAR System

The SAR measurements were conducted with the dosimetric probe EX3DV4, designed in the classical triangular configuration [7] (see Figure 4-3) and optimized for dosimetric evaluation. The probe is constructed using the thick film technique; with printed resistive lines on ceramic substrates. The probe is equipped with an optical multi-fiber line ending at the front of the probe tip. It is connected to the EOC box on the robot arm and provides an automatic detection of the phantom surface. Half of the fibers are connected to a pulsed infrared transmitter, the other half to a synchronized receiver. As the probe approaches the surface, the reflection from the surface produces a coupling from the transmitting to the receiving fibers. This reflection increases first during the approach, reaches maximum and then decreases. If the probe is flatly touching the surface, the coupling is zero. The distance of the coupling maximum to the surface is independent of the surface reflectivity and largely independent of the surface to probe angle. The DASY4 software reads the reflection during a software approach

and looks for the maximum using a 2nd order fitting (see Figure 5-1). The approach is stopped at reaching the maximum.

4.2 Probe Specifications



Model:	ES3DV3, EX3DV4
Frequency Range:	10 MHz – 6.0 GHz (EX3DV4) 10 MHz – 4 GHz (ES3DV3)
Calibration:	In brain and muscle simulating tissue at Frequencies from 835 up to 5800MHz
Linearity:	± 0.2 dB (30 MHz to 6 GHz) for EX3DV4 ± 0.2 dB (30 MHz to 4 GHz) for ES3DV3
Dynamic Range:	10 mW/kg – 100 W/kg
Probe Length:	330 mm
Probe Tip Length:	20 mm
Body Diameter:	12 mm
Tip Diameter:	2.5 mm (3.9mm for ES3DV3)
Tip-Center:	1 mm (2.0 mm for ES3DV3)
Application:	SAR Dosimetry Testing Compliance tests of mobile phones Dosimetry in strong gradient fields



Figure 4-2
Near-Field Probe



Figure 4-3
Triangular Probe
Configuration

FCC ID: A3LSWCU200	 PCTEST ENGINEERING LABORATORY, INC.	CERTIFICATION REPORT	 SAMSUNG	Reviewed by: Quality Manager
SAR Filename: 0810061478.A3L	Test Dates: 11/25/08 - 03/02/09	EUT Type: WiMAX USB Modem		Page 7 of 23

5 PROBE CALIBRATION PROCESS

5.1 Dosimetric Assessment Procedure

Each E-Probe/Probe amplifier combination has unique calibration parameters. A TEM cell calibration procedure is conducted to determine the proper amplifier settings to enter in the probe parameters. The amplifier settings are determined for a given frequency by subjecting the probe to a known E-field density (1 mW/cm²) using an RF Signal generator, TEM cell, and RF Power Meter.

5.2 Free Space Assessment

The free space E-field from amplified probe outputs is determined in a test chamber. This calibration can be performed in a TEM cell if the frequency is below 1 GHz and in a waveguide or other methodologies above 1 GHz for free space. For the free space calibration, the probe is placed in the volumetric center of the cavity and at the proper orientation with the field. The probe is rotated 360 degrees until the three channels show the maximum reading. The power density readings equates to 1 mW/cm².

5.3 Temperature Assessment

E-field temperature correlation calibration is performed in a flat phantom filled with the appropriate simulated brain tissue. The E-field in the medium correlates with the temperature rise in the dielectric medium. For temperature correlation calibration a RF transparent thermistor-based temperature probe is used in conjunction with the E-field probe.

$$SAR = C \frac{\Delta T}{\Delta t}$$

where:

- Δt = exposure time (30 seconds),
- C = heat capacity of tissue (brain or muscle),
- ΔT = temperature increase due to RF exposure.

$$SAR = \frac{|E|^2 \cdot \sigma}{\rho}$$

where:

- σ = simulated tissue conductivity,
- ρ = Tissue density (1.25 g/cm³ for brain tissue)



SAR is proportional to $\Delta T/\Delta t$, the initial rate of tissue heating, before thermal diffusion takes place. Now it's possible to quantify the electric field in the simulated tissue by equating the thermally derived SAR to the E- field;



Figure 5-1 E-Field and Temperature measurements at 900MHz [7]



Figure 5-2 E-Field and temperature measurements at 1.9GHz [7]

FCC ID: A3LSWCU200		CERTIFICATION REPORT		Reviewed by: Quality Manager
SAR Filename: 0810061478.A3L	Test Dates: 11/25/08 - 03/02/09	EUT Type: WiMAX USB Modem		Page 8 of 23

6 PHANTOM AND EQUIVALENT TISSUES

6.1 SAM Phantoms



Figure 6-1
SAM Phantoms

The SAM Twin Phantom V4.0 is constructed of a fiberglass shell integrated in a wooden table. The shape of the shell is based on data from an anatomical study designed to determine the maximum exposure in at least 90% of all users [11][12]. It enables the dosimetric evaluation of left and right hand phone usage as well as body mounted usage at the flat phantom region. A cover prevents the evaporation of the liquid. Reference markings on the Phantom allow the complete setup of all predefined phantom positions and measurement grids by manually teaching three points in the robot.

6.2 Brain & Muscle Simulating Mixture Characterization



Figure 6-2
Head Simulated



The brain and muscle mixtures consist of a viscous gel using hydroxethylcellulose (HEC) gelling agent and saline solution (see Table 6-1). Preservation with a bactericide is added and visual inspection is made to make sure air bubbles are not trapped during the mixing process. The mixture is calibrated to obtain proper dielectric constant (permittivity) and conductivity of the desired tissue. The head tissue dielectric parameters recommended by the IEEE SCC-34/SC-2 have been incorporated in the following table. Other head and body tissue parameters that have not been specified in IEEE-1528 are derived from the tissue dielectric parameters computed from the 4-Cole-Cole equations. The mixture characterizations used for the brain and muscle tissue simulating liquids are according to the data by C. Gabriel and G. Hartsgrrove [13]. (See Table 6-1)

Table 6-1
Composition of the Brain & Muscle Tissue Equivalent Matter

Frequency (MHz)	300			450			835			900			1450			1800				1900		1950		2000		2100		2450		3000	
Recipe #	1	1	3	1	1	2	3	1	1	2	3	1	1	2	2	3	1	2	4	1	1	2	2	3	2	2	3	2			
Ingredients: (% by weight)																															
1,3-Propanediol								64.81																							
Bactericide	0.19	0.19	0.50	0.10	0.10			0.50									0.50											0.50			
Diaceta			48.90					49.20									49.43												49.75		
DGBE									45.41	47.00	13.84	44.92					44.94	13.84	45.00	50.00	50.00	50.00	7.99	7.99				7.99			
HEC	0.98	0.98		1.00	1.00																										
NaCl	5.95	3.95	1.70	1.45	1.48	0.79	1.10	0.67	0.36	0.35	0.18	0.64	0.18	0.35												0.16	0.16		0.16		
Sucrose	55.32	56.32		57.00	56.50																										
Triton X-100														30.45						30.45						19.97	19.97		19.97		
Water	37.56	38.56	48.90	40.45	40.92	34.40	49.20	53.80	52.64	55.36	54.90	49.43	54.90	55.36	55.00	50.00	50.00	50.00	50.00	50.00	50.00	50.00	71.88	71.88	49.75	71.88		71.88			
Measured dielectric parameters																															
ϵ'_r	46.00	43.4	44.3	41.6	41.2	41.8	42.7	40.9	39.3	41	40.4	39.2	39.9	41	40.1	37	36.8	41.1	40.3	39.2	37.9										
σ (S/m)	0.86	0.87	0.9	0.9	0.98	0.97	0.99	1.21	1.39	1.38	1.4	1.42	1.38	1.41	1.4	1.51	1.53	1.88	1.82	2.46											
Temp. (°C)	22	22	20	22	22	22	20	22	22	21	22	20	21	20	21	20	22	20	20	20	20	20	20	20	20	20	20	20	20		
Target dielectric parameters (Table 2)																															
ϵ'_r	45.30	43.50	41.5		41.50		40.5						40.0					39.80		39.2		38.5									
σ (S/m)	0.87	0.87	0.9		0.97		1.2						1.4					1.49		1.8		2.4									

NOTE—Multiple columns for any single frequency are optional recipes. Recipe # reference: 1 (Kanda et al. [885]), 2 (Vignosa [B145]), 3 (Pyman and Gabriel [B119]), 4 (Falcovaga et al. [B50]).

*The formulas containing Triton X-100 and corresponding measured parameters are under review and verification.

FCC ID: A3LSWCU200		CERTIFICATION REPORT		Reviewed by: Quality Manager
SAR Filename: 0810061478.A3L	Test Dates: 11/25/08 - 03/02/09	EUT Type: WiMAX USB Modem		Page 9 of 23

7

DOSIMETRIC ASSESSMENT & PHANTOM SPECS

7.1 Measurement Procedure

The evaluation was performed using the following procedure:

1. The SAR measurement was taken at a selected spatial reference point to monitor power variations during testing. This fixed point was measured and used as a reference value.
2. The SAR distribution at the exposed side of the phantom was measured at a distance of 3.0mm from the inner surface of the shell. The horizontal grid spacing was 15mm x 15mm.
3. Based on the area scan data, the area of the maximum absorption was determined by spline interpolation. Around this point, a volume of 32mm x 32mm x 30mm (fine resolution volume scan, zoom scan) was assessed by measuring 5 x 5 x 7 points. On this basis of this data set, the spatial peak SAR value was evaluated with the following procedure (see Figure 7-1):
 - a. The data at the surface was extrapolated since the center of the dipoles is 2.7mm away from the tip of the probe and the distance between the surface and the lowest measuring point is 1.2mm. The extrapolation was based on a least square algorithm [15]. A polynomial of the fourth order was calculated through the points in the z-axis. This polynomial was then used to evaluate the points between the surface and the probe tip.
 - b. The maximum interpolated value was found with a software algorithm. Around this maximum, the SAR values averaged over the spatial volumes (1g or 10g) were computed using 3D-Spline interpolation. The 3D-spline is composed of three one-dimensional splines with the "Not a knot" condition (in x, y, and z directions) [15][16]. The volume was integrated with the trapezoidal algorithm. One thousand points (10 x 10 x 10) were interpolated to calculate the average.
 - c. All neighboring volumes were evaluated until no neighboring volume with a higher average value was found.
4. The SAR reference value, at the same location as step 1, was re-measured to measure drift. If the value drifted by more than 5%, the evaluation was repeated.

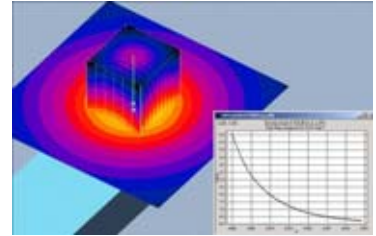



Figure 7-1
Sample SAR Area Scan

7.2 Specific Anthropomorphic Mannequin (SAM) Specifications

The phantom for handset SAR assessment testing is a low-loss dielectric shell, with shape and dimensions derived from the anthropometric data of the 90th percentile adult male head dimensions as tabulated by the US Army. The SAM Twin Phantom shell is bisected along the mid-sagittal plane into right and left halves (see Figure 7-2). The perimeter sidewalls of each phantom halves are extended to allow filling with liquid to a depth that is sufficient to minimized reflections from the upper surface. The liquid depth is maintained at a minimum depth of 15cm to minimize reflections from the upper surface.



Figure 7-2
SAM Twin Phantom Shell

FCC ID: A3LSWCU200		CERTIFICATION REPORT		Reviewed by: Quality Manager
SAR Filename: 0810061478.A3L	Test Dates: 11/25/08 - 03/02/09	EUT Type: WiMAX USB Modem		Page 10 of 23

8 TEST CONFIGURATION POSITIONS

8.1 SAR for Notebooks and Lap-touching Devices

Lap-touching devices that have transmitting antennas located less than 20 cm from the lap of the user require routine SAR evaluation. Such devices are considered portable and are capable of being held to the body. Devices are to be setup touching the phantom and are configured with maximum output power during SAR assessment for a worst-case SAR evaluation.



Figure 8-1
Notebook Setup for SAR

8.2 Positioning for Convertible and Slate Tablet Computers



Figure 8-2
Tablet Computer Form Factors

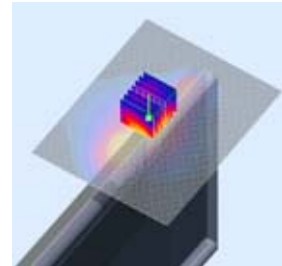

Figure 8-3
Tablet PC Body SAR

KDB 447498. Tablet (notepad) computers are tested in a lap-held position with the bottom of the computer in direct contact against a flat phantom for all user-enabled portrait and landscape positions.

8.3 SAR test procedure for USB Dongles

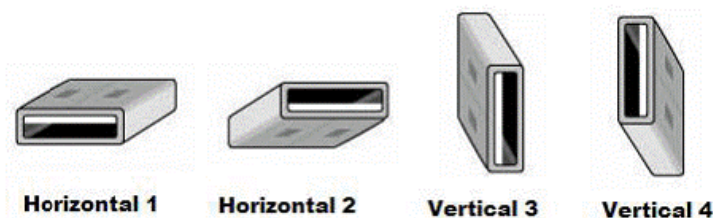



Figure 8-4
USB Dongle Test Configurations

KDB447498. Devices that can be connected to a host through a cable must be tested with the device positioned in all applicable orientations against the flat phantom. A separation distance ≤ 0.5 cm is required for USB-dongle transmitters.

FCC ID: A3LSWCU200		CERTIFICATION REPORT		Reviewed by: Quality Manager
SAR Filename: 0810061478.A3L	Test Dates: 11/25/08 - 03/02/09	EUT Type: WiMAX USB Modem		Page 11 of 23

8.4 SAR Testing with IEEE 802.11 a/b/g Transmitters

Normal network operating configurations are not suitable for measuring the SAR of 802.11 a/b/g transmitters. Unpredictable fluctuations in network traffic and antenna diversity conditions can introduce undesirable variations in SAR results. The SAR for these devices should be measured using chipset based test mode software to ensure the results are consistent and reliable.



8.4.1 General Device Setup



Chipset based test mode software is hardware dependent and generally varies among manufacturers. The device operating parameters established in test mode for SAR measurements must be identical to those programmed in production units, including output power levels, amplifier gain settings and other RF performance tuning parameters. The test frequencies should correspond to actual channel frequencies defined for domestic use. SAR for devices with switched diversity should be measured with only one antenna transmitting at a time during each SAR measurement, according to a fixed modulation and data rate. The same data pattern should be used for all measurements.

8.4.2 Frequency Channel Configurations [22]

802.11 a/b/g and 4.9 GHz operating modes are tested independently according to the service requirements in each frequency band. 802.11 b/g modes are tested on channels 1, 6 and 11. 802.11a is tested for UNII operations on channels 36 and 48 in the 5.15-5.25 GHz band; channels 52 and 64 in the 5.25-5.35 GHz band; channels 104, 116, 124 and 136 in the 5.470-5.725 GHz band; and channels 149 and 161 in the 5.8 GHz band. When 5.8 GHz §15.247 is also available, channels 149, 157 and 165 should be tested instead of the UNII channels. 4.9 GHz is tested on channels 1, 10 and 5 or 6, whichever has the higher output power, for 5 MHz channels; channels 11, 15 and 19 for 10 MHz channels; and channels 21 and 25 for 20 MHz channels. These are referred to as the “default test channels”. 802.11g mode was evaluated only if the output power was 0.25 dB higher than the 802.11b mode.

**Table 8-1
802.11 Test Channels per FCC Requirements**

Mode	GHz	Channel	Turbo Channel	“Default Test Channels”		
				§15.247	UNII	
				802.11b	802.11g	
802.11 b/g	2.412	1		√	∇	
	2.437	6		√	∇	
	2.462	11		√	∇	
802.11a	5.18	36				√
	5.20	40	42 (5.21 GHz)			•
	5.22	44				•
	5.24	48	50 (5.25 GHz)			√
	5.26	52				√
	5.28	56	58 (5.29 GHz)			•
	5.30	60				•
	5.32	64				√
	5.500	100				•
	5.520	104				√
	5.540	108				•
	5.560	112				•
	5.580	116				√
	5.600	120	Unknown			•
	5.620	124				√
	5.640	128				•
	5.660	132				•
	5.680	136				√
	5.700	140				•
	UNII or §15.247	5.745	149		√	
5.765		153	152 (5.76 GHz)		•	•
5.785		157		√		•
5.805		161	160 (5.80 GHz)		•	√
§15.247	5.825	165		√		

FCC ID: A3LSWCU200	 PCTEST ENGINEERING LABORATORY, INC.	CERTIFICATION REPORT	 SAMSUNG	Reviewed by: Quality Manager
SAR Filename: 0810061478.A3L	Test Dates: 11/25/08 - 03/02/09	EUT Type: WiMAX USB Modem		Page 12 of 23

9



BRS/EBS TEST CONFIGURATION

Power measurements were performed using a factory test code under digital average power .

9.1 Devices with WIMAX

Profile	Range (GHz)	BW (MHz)	CF Start (MHz)	CF Stop (MHz)
3A-5	2.496 – 2.69	5	2498.5	2687.5
3A-10	2.496 – 2.69	10	2501	2685
4A	3.3 – 3.4	5	3302.5	3397.5
4B	3.3 – 3.4	7	3303.5	3396.5
4C	3.3 – 3.4	10	3305	3395

Parameters	Values			
System Channel Bandwidth (MHz)	1.25	5	10	20
Sampling Frequency (F_D in MHz)	1.4	5.6	11.2	22.4
FFT Size (N_{FFT})	128	512	1024	2048
Number of Sub-Channels	2	8	16	32
Sub-Carrier Frequency Spacing	10.94 kHz			
Useful Symbol Time ($T_b = 1/f$)	91.4 microseconds			
Guard Time ($T_g = T_b/8$)	11.4 microseconds			
OFDMA Symbol Duration ($T_s = T_b + T_g$)	102.9 microseconds			
Number of OFDMA Symbols (5 ms Frame)	48			

FCC ID: A3LSWCU200		CERTIFICATION REPORT		Reviewed by: Quality Manager
SAR Filename: 0810061478.A3L	Test Dates: 11/25/08 - 03/02/09	EUT Type: WiMAX USB Modem		Page 13 of 23

9.2 Device Conducted Powers



OFDM Format																			
Frequency				5MHZ								10MHZ							
10MHz		5MHz		QPSK 1/2		QPSK 3/4		16QAM 1/2		16QAM 3/4		QPSK 1/2		QPSK 3/4		16QAM 1/2		16QAM 3/4	
10MHz	5MHz	10MHz	5MHz	BAMC	PUSC	BAMC	PUSC	BAMC	PUSC	BAMC	PUSC	BAMC	PUSC	BAMC	PUSC	BAMC	PUSC	BAMC	PUSC
-	2498.5	-	512	22.8	22.8	23.5	22.9	23.3	22.2	23.3	22.5	-	-	-	-	-	-	-	-
2501	-	1024	-	-	-	-	-	-	-	-	-	23.4	22.6	23.5	23.4	23.8	23	23.3	23
-	2600	-	512	22.9	23	23.3	23.2	23.3	22.6	23.3	22.7	-	-	-	-	-	-	-	-
2600	-	1024	-	-	-	-	-	-	-	-	-	23.4	23.3	23.5	23.4	23.7	23.8	23.3	23.1
-	2687.5	-	512	23	22.8	23.4	23	23.1	23.1	23	22.7	-	-	-	-	-	-	-	-
2685	-	1024	-	-	-	-	-	-	-	-	-	23.2	22.4	23.3	23.1	22.6	23.5	23	22.7

9.3 Sample Crest Factor Calculation

$$\text{Crest Factor} = \frac{\text{frame length}}{[\# \text{ of uplink traffic symbols}] \times [\text{symbol time}]}$$

For worst-case BAMC QPSK, 1024P, 10MHz measurement,

$$\begin{aligned} \text{SPEAG Probe Crest Factor}_{\text{BAMC QPSK, 10MHZ}} &= \frac{5000 \mu\text{s}}{17 \times 102.857 \mu\text{s}} \\ &= \mathbf{2.86} \end{aligned}$$



FCC ID: A3LSWCU200		CERTIFICATION REPORT		Reviewed by: Quality Manager
SAR Filename: 0810061478.A3L	Test Dates: 11/25/08 - 03/02/09	EUT Type: WiMAX USB Modem		Page 14 of 23

9.4 Mobile WIMAX PHY Data Rate with Sub Channel

Mod.	Code Rate	5 MHz Channel		10 MHz Channel	
		Downlink Rate, Mbps	Uplink Rate, Mbps	Downlink Rate, Mbps	Uplink Rate, Mbps
QPSK	1/2 CTC, 6x	0.53	0.38	1.06	0.78
	1/2 CTC, 4x	0.79	0.57	1.58	1.18
	1/2 CTC, 2x	1.58	1.14	3.17	2.35
	1/2 CTC, 1x	3.17	2.28	6.34	4.70
	3/4 CTC	4.75	3.43	9.50	7.06
16QAM	1/2 CTC	6.34	4.57	12.07	9.41
	3/4 CTC	9.50	6.85	19.01	14.11
64QAM	1/2 CTC	9.50	6.85	19.01	14.11
	2/3 CTC	12.67	9.14	26.34	18.82
	3/4 CTC	14.26	10.28	28.51	21.17
	5/6 CTC	15.84	11.42	31.68	23.52

9.5 Test Condition

Testing was performed using Samsung FTM. Please see description for more details.

FCC ID: A3LSWCU200	 PCTEST ENGINEERING LABORATORY, INC.	CERTIFICATION REPORT		Reviewed by: Quality Manager
SAR Filename: 0810061478.A3L	Test Dates: 11/25/08 - 03/02/09	EUT Type: WiMAX USB Modem		Page 15 of 23

10 ANSI/IEEE C95.1-2005 RF EXPOSURE LIMITS

10.1 Uncontrolled Environment

UNCONTROLLED ENVIRONMENTS are defined as locations where there is the exposure of individuals who have no knowledge or control of their exposure. The general population/uncontrolled exposure limits are applicable to situations in which the general public may be exposed or in which persons who are exposed as a consequence of their employment may not be made fully aware of the potential for exposure or cannot exercise control over their exposure. Members of the general public would come under this category when exposure is not employment-related; for example, in the case of a wireless transmitter that exposes persons in its vicinity.



10.2 Controlled Environment

CONTROLLED ENVIRONMENTS are defined as locations where there is exposure that may be incurred by persons who are aware of the potential for exposure, (i.e. as a result of employment or occupation). In general, occupational/controlled exposure limits are applicable to situations in which persons are exposed as a consequence of their employment, who have been made fully aware of the potential for exposure and can exercise control over their exposure. This exposure category is also applicable when the exposure is of a transient nature due to incidental passage through a location where the exposure levels may be higher than the general population/uncontrolled limits, but the exposed person is fully aware of the potential for exposure and can exercise control over his or her exposure by leaving the area or by some other appropriate means.

Table 10-1
SAR Human Exposure Specified in ANSI/IEEE C95.1-2005 and Health Canada Safety Code 6

HUMAN EXPOSURE LIMITS		
	UNCONTROLLED ENVIRONMENT <i>General Population</i> (W/kg) or (mW/g)	CONTROLLED ENVIRONMENT <i>Occupational</i> (W/kg) or (mW/g)
SPATIAL PEAK SAR Brain	1.6	8.0
SPATIAL AVERAGE SAR Whole Body	0.08	0.4
SPATIAL PEAK SAR Hands, Feet, Ankles, Wrists	4.0	20



- 1 The Spatial Peak value of the SAR averaged over any 1 gram of tissue (defined as a tissue volume in the shape of a cube) and over the appropriate averaging time.
- 2 The Spatial Average value of the SAR averaged over the whole body.
- 3 The Spatial Peak value of the SAR averaged over any 10 grams of tissue (defined as a tissue volume in the shape of a cube) and over the appropriate averaging time.

FCC ID: A3LSWCU200	 PCTEST ENGINEERING LABORATORY, INC.	CERTIFICATION REPORT	 SAMSUNG	Reviewed by: Quality Manager
SAR Filename: 0810061478.A3L	Test Dates: 11/25/08 - 03/02/09	EUT Type: WiMAX USB Modem		Page 16 of 23

11 MEASUREMENT UNCERTAINTIES

a	b	c	d	e= f(d,k)	f	g	h = c x f/e	i = c x g/e	k
Uncertainty Component	IEEE 1528 Sec.	Tol. (± %)	Prob. Dist.	Div.	c _i 1gm	c _i 10 gms	1gm u _i (± %)	10gms u _i (± %)	v _i
Measurement System									
Probe Calibration	E2.1	6.6	N	1	1.0	1.0	6.6	6.6	∞
Axial Isotropy	E2.2	0.25	N	1	0.7	0.7	0.2	0.2	∞
Hemishperical Isotropy	E2.2	1.3	N	1	1.0	1.0	1.3	1.3	∞
Boundary Effect	E2.3	0.4	N	1	1.0	1.0	0.4	0.4	∞
Linearity	E2.4	0.3	N	1	1.0	1.0	0.3	0.3	∞
System Detection Limits	E2.5	5.1	N	1	1.0	1.0	5.1	5.1	∞
Readout Electronics	E2.6	1.0	N	1	1.0	1.0	1.0	1.0	∞
Response Time	E2.7	0.8	R	1.73	1.0	1.0	0.5	0.5	∞
Integration Time	E2.8	2.6	R	1.73	1.0	1.0	1.5	1.5	∞
RF Ambient Conditions	E6.1	3.0	R	1.73	1.0	1.0	1.7	1.7	∞
Probe Positioner Mechanical Tolerance	E6.2	0.4	R	1.73	1.0	1.0	0.2	0.2	∞
Probe Positioning w/ respect to Phantom	E6.3	2.9	R	1.73	1.0	1.0	1.7	1.7	∞
Extrapolation, Interpolation & Integration algorithms for Max. SAR Evaluation	E5	1.0	R	1.73	1.0	1.0	0.6	0.6	∞
Test Sample Related									
Test Sample Positioning	E4.2	6.0	N	1	1.0	1.0	6.0	6.0	287
Device Holder Uncertainty	E4.1	3.32	R	1.73	1.0	1.0	1.9	1.9	∞
Output Power Variation - SAR drift measurement	6.6.2	5.0	R	1.73	1.0	1.0	2.9	2.9	∞
Phantom & Tissue Parameters									
Phantom Uncertainty (Shape & Thickness tolerances)	E3.1	4.0	R	1.73	1.0	1.0	2.3	2.3	∞
Liquid Conductivity - deviation from target values	E3.2	5.0	R	1.73	0.64	0.43	1.8	1.2	∞
Liquid Conductivity - measurement uncertainty	E3.3	3.8	N	1	0.64	0.43	2.4	1.6	6
Liquid Permittivity - deviation from target values	E3.2	5.0	R	1.73	0.60	0.49	1.7	1.4	∞
Liquid Permittivity - measurement uncertainty	E3.3	4.5	N	1	0.60	0.49	2.7	2.2	6
Combined Standard Uncertainty (k=1)	RSS						12.4	12.0	299
Expanded Uncertainty (95% CONFIDENCE LEVEL)	k=2						24.7	24.0	

The above measurement uncertainties are according to IEEE Std. 1528-2003

FCC ID: A3LSWCU200		CERTIFICATION REPORT		Reviewed by: Quality Manager
SAR Filename: 0810061478.A3L	Test Dates: 11/25/08 - 03/02/09	EUT Type: WiMAX USB Modem		Page 17 of 23

12 SYSTEM VERIFICATION

12.1 Tissue Verification

**Table 12-1
Measured Tissue Properties**

Calibrated Date:	11/26/2008	11/26/2008	11/26/2008	03/02/2009	03/02/2009	03/02/2009
	2500M		2600M		2700M	
	Target	Measured	Target	Measured	Target	Measured
Dielectric Constant	52.64	51.19	52.51	50.63	52.38	50.25
Conductivity	2.02	2.11	2.16	2.25	2.30	2.36

12.2 Test System Verification

Prior to assessment, the system is verified to $\pm 10\%$ of the specifications at 2600 MHz by using the system validation kit(s). (Graphic Plots Attached)

**Table 12-2
System Verification Results**

System Verification TARGET & MEASURED							
Date:	Amb. Temp (°C)	Liquid Temp (°C)	Input Power (W)	Tissue Frequency (MHz)	Targeted SAR _{1g} (mW)	Measured SAR _{1g} (mW)	Deviation (%)
11/25/2008	22.7	21.6	0.100	2600	5.84	6.22	6.51%
03/02/2009	22.3	21.7	0.100	2600	5.84	5.87	0.51%

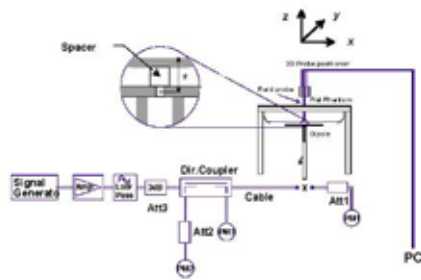

**Figure 12-1
System Verification Setup Diagram**



**Figure 12-2
System Verification Setup Photo**

FCC ID: A3LSWCU200	PCTEST ENGINEERING LABORATORY, INC.	CERTIFICATION REPORT	SAMSUNG	Reviewed by: Quality Manager
SAR Filename: 0810061478.A3L	Test Dates: 11/25/08 - 03/02/09	EUT Type: WiMAX USB Modem		Page 18 of 23



13 SAR DATA SUMMARY

13.1 Body SAR Results

MEASUREMENT RESULTS							
FREQUENCY	Mode	Begin/ End Power [dBm]		Device Test Position	BW	Spacing	SAR (W/kg)
MHz		Start	End				
2501	BAMCQPSK3/4	23.50	23.33	Horizontal 2	10MHz	0.5 - 1.0 cm	0.968
2501	BAMCQPSK1/2	23.50	23.31	Horizontal 2	10MHz	0.5 - 1.0 cm	0.884
2600	BAMCQPSK3/4	23.50	23.65	Horizontal 2	10MHz	0.5 - 1.0 cm	0.764
2685	BAMCQPSK3/4	23.30	23.22	Horizontal 2	10MHz	0.5 - 1.0 cm	0.798
2501	PUSC16QAM3/4	23.00	23.14	Horizontal 2	10MHz	0.5 - 1.0 cm	0.891
2501	PUSCQPSK3/4	23.40	23.21	Horizontal 2	10MHz	0.5 - 1.0 cm	0.800
2501	BAMC16QAM1/2	23.80	23.92	Horizontal 2	10MHz	0.5 - 1.0 cm	0.857
2501	BAMCQPSK3/4	23.50	23.63	Horizontal 2	5MHz	0.5 - 1.0 cm	0.865
2501	BAMC16QAM1/2	23.30	23.47	Horizontal 2	5MHz	0.5 - 1.0 cm	0.835
2501	PUSCQPSK3/4	22.90	22.79	Horizontal 2	5MHz	0.5 - 1.0 cm	0.828
2501	PUSC16QAM3/4	22.50	22.35	Horizontal 2	5MHz	0.5 - 1.0 cm	0.823
2501	BAMCQPSK3/4	23.50	23.59	Horizontal 1	10MHz	0.5 cm	0.316
2501	BAMCQPSK3/4	23.50	23.47	Horizontal 1	10MHz	0.4 cm w/ Laptop	0.427
2501	BAMCQPSK3/4	23.50	23.63	Horizontal 1	5MHz	0.4 cm w/ Laptop	0.453
2501	BAMCQPSK3/4	23.50	23.61	Vertical 3	10MHz	0.5 cm	0.669
2501	BAMCQPSK3/4	23.50	23.60	Vertical 3	10MHz	0.05 cm w/ Laptop	1.180
2501	BAMCQPSK3/4	23.50	23.60	Vertical 3	5MHz	0.05 cm w/ Laptop	1.160
2501	BAMCQPSK3/4	23.50	23.41	Vertical 4	10MHz	0.5 cm	0.930
2501	BAMCQPSK3/4	23.50	23.44	Back	10MHz	0.5 cm	0.531
ANSI / IEEE C95.1 2005 - SAFETY LIMIT Spatial Peak Uncontrolled Exposure/General Population						Muscle 1.6 W/kg (mW/g) averaged over 1 gram	

Notes:

1. The test data reported are the worst-case SAR value with the position set in a typical configuration. Test procedures used are according to FCC/OET Bulletin 65, Supplement C [July 2001].
2. All modes of operation were investigated, and worst-case results are reported.
3. Tissue parameters and temperatures are listed on the SAR plots.
4. Liquid tissue depth is 15.1 cm. ± 0.1.
5. KDB447498 and KDB618891 procedures were followed for USB Dongle.
6. Horizontal 2 position tested with a spacing of 0.5 cm at the hinge and 1.0 cm at the distal end of the device per FCC meeting on 11/4/08. Spacing was measured from the phantom to the main device housing.



FCC ID: A3LSWCU200		CERTIFICATION REPORT		Reviewed by: Quality Manager
SAR Filename: 0810061478.A3L	Test Dates: 11/25/08 - 03/02/09	EUT Type: WiMAX USB Modem		Page 19 of 23

14 EQUIPMENT LIST

Manufacturer	Model	Description	Cal Date	Cal Interval	Cal Due	Serial Number
Agilent	8648D	(9kHz-4GHz) Signal Generator	10/11/2007	Biennial	10/11/2009	3613A00315
Agilent	8753E	(30kHz-6GHz) Network Analyzer	3/12/2008	Annual	3/12/2009	JP38020182
Agilent	E5515C	Wireless Communications Test Set	6/8/2007	Biennial	6/8/2009	GB46110872
Agilent	E5515C	Wireless Communications Test Set	6/8/2007	Biennial	6/8/2009	GB46310798
Agilent	E5515C	Wireless Communications Test Set	9/10/2008	Biennial	9/10/2010	GB41450275
Agilent	E6651A	Mobile WiMAX Tester	8/23/2007	Biennial	8/23/2009	MY47310109
Agilent	E8257D	(250kHz-20GHz) Signal Generator	3/8/2007	Biennial	3/8/2009	MY45470194
Gigatronics	80701A	(0.05-18GHz) Power Sensor	8/18/2008	Annual	8/18/2009	1833460
Gigatronics	8651A	Universal Power Meter	8/18/2008	Annual	8/18/2009	8650319
Index SAR	IXTL-010	Dielectric Measurement Kit	N/A		N/A	N/A
Index SAR	IXTL-030	30MM TEM line for 6 GHz	N/A		N/A	N/A
Rohde & Schwarz	CMU200	Base Station Simulator	5/29/2008	Annual	5/29/2009	836371/0079
Rohde & Schwarz	CMU200	Base Station Simulator	7/23/2008	Annual	7/23/2009	109892
Rohde & Schwarz	NRVD	Dual Channel Power Meter	8/20/2008	Biennial	8/20/2010	101695
Rohde & Schwarz	NRVS	Single Channel Power Meter	7/3/2007	Biennial	7/3/2009	835360/0079
Rohde & Schwarz	NRV-Z32	Peak Power Sensor (100uW-2W)	12/5/2008	Biennial	12/5/2010	100155
Rohde & Schwarz	NRV-Z33	Peak Power Sensor (1mW-20W)	12/5/2008	Biennial	12/5/2010	100004
Rohde & Schwarz	NRV-Z53	Power Sensor	7/3/2007	Biennial	7/3/2009	846076/0007
SPEAG	D1450V2	1450 MHz SAR Dipole	6/11/2007	Biennial	6/11/2009	1025
SPEAG	D1765V2	1765 MHz SAR Dipole	6/11/2007	Biennial	6/11/2009	1008
SPEAG	D1900V2	1900 MHz SAR Dipole	1/20/2009	Biennial	1/20/2011	502
SPEAG	D2300V2	2300 MHz SAR Dipole	3/6/2008	Biennial	3/6/2010	1008
SPEAG	D2450V2	2450 MHz SAR Dipole	9/26/2007	Biennial	9/26/2009	719
SPEAG	D2450V2	2450 MHz SAR Dipole	1/8/2009	Biennial	1/8/2011	797
SPEAG	D2600V2	2600 MHz SAR Dipole	1/30/2008	Biennial	1/30/2010	1004
SPEAG	D5GHzV2	5 GHz SAR Dipole	9/25/2007	Biennial	9/25/2009	1007
SPEAG	D5GHzV2	5 GHz SAR Dipole	1/15/2009	Biennial	1/15/2011	1057
SPEAG	D835V2	835 MHz SAR Dipole	1/19/2009	Biennial	1/19/2011	4d047
SPEAG	D835V2	835 MHz SAR Dipole	8/27/2007	Biennial	8/27/2009	4d026
SPEAG	DAE3	Dasy Data Acquisition Electronics	10/17/2008	Annual	10/17/2009	455
SPEAG	DAE4	Dasy Data Acquisition Electronics	6/26/2008	Annual	6/26/2009	704
SPEAG	DAE4	Dasy Data Acquisition Electronics	8/25/2008	Annual	8/25/2009	665
SPEAG	DAE4	Dasy Data Acquisition Electronics	1/21/2009	Annual	1/21/2010	649
SPEAG	ES3DV2	SAR Probe	10/21/2008	Annual	10/21/2009	3022
SPEAG	EX3DV4	SAR Probe	6/26/2008	Annual	6/26/2009	3589
SPEAG	EX3DV4	SAR Probe	8/26/2008	Annual	8/26/2009	3561
SPEAG	EX3DV4	SAR Probe	1/21/2009	Annual	1/21/2010	3550
SPEAG	DAE4	Dasy Data Acquisition Electronics	7/30/2008	Annual	7/30/2009	859

Notes:

The E-field probe was calibrated by SPEAG, by the waveguide technique procedure. Dipole Validation measurement is performed by PCTEST prior to SAR evaluation. The brain simulating material is calibrated by PCTEST using the dielectric probe system and network analyzer to determine the conductivity and permittivity (dielectric constant) of the brain-equivalent material.



FCC ID: A3LSWCU200		CERTIFICATION REPORT		Reviewed by: Quality Manager
SAR Filename: 0810061478.A3L	Test Dates: 11/25/08 - 03/02/09	EUT Type: WiMAX USB Modem		Page 20 of 23

15 CONCLUSION

15.1 Measurement Conclusion



The SAR evaluation indicates that the EUT complies with the RF radiation exposure limits of the FCC, with respect to all parameters subject to this test. These measurements were taken to simulate the RF effects of RF exposure under worst-case conditions. Precise laboratory measures were taken to assure repeatability of the tests. The results and statements relate only to the item(s) tested.

Please note that the absorption and distribution of electromagnetic energy in the body are very complex phenomena that depend on the mass, shape, and size of the body, the orientation of the body with respect to the field vectors, and the electrical properties of both the body and the environment. Other variables that may play a substantial role in possible biological effects are those that characterize the environment (e.g. ambient temperature, air velocity, relative humidity, and body insulation) and those that characterize the individual (e.g. age, gender, activity level, debilitation, or disease). Because various factors may interact with one another to vary the specific biological outcome of an exposure to electromagnetic fields, any protection guide should consider maximal amplification of biological effects as a result of field-body interactions, environmental conditions, and physiological variables. [3]

FCC ID: A3LSWCU200		CERTIFICATION REPORT		Reviewed by: Quality Manager
SAR Filename: 0810061478.A3L	Test Dates: 11/25/08 - 03/02/09	EUT Type: WiMAX USB Modem		Page 21 of 23

16 REFERENCES

- [1] Federal Communications Commission, ET Docket 93-62, Guidelines for Evaluating the Environmental Effects of Radiofrequency Radiation, Aug. 1996.
- [2] ANSI/IEEE C95.1-2005, American National Standard safety levels with respect to human exposure to radio frequency electromagnetic fields, 300kHz to 100GHz, New York: IEEE, April 2006.
- [3] ANSI/IEEE C95.3-2002, IEEE Recommended Practice for the Measurement of Potentially Hazardous Electromagnetic Fields - RF and Microwave, New York: IEEE, December 2002.
- [4] Federal Communications Commission, OET Bulletin 65 (Edition 97-01), Supplement C (Edition 01-01), Evaluating Compliance with FCC Guidelines for Human Exposure to Radiofrequency Electromagnetic Fields, July 2001.
- [5] IEEE Standards Coordinating Committee 34 – IEEE Std. 1528-2003, Recommended Practice for Determining the Peak Spatial-Average Specific Absorption Rate (SAR) in the Human Body Due to Wireless Communications Devices.
- [6] NCRP, National Council on Radiation Protection and Measurements, Biological Effects and Exposure Criteria for RadioFrequency Electromagnetic Fields, NCRP Report No. 86, 1986. Reprinted Feb. 1995.
- [7] T. Schmid, O. Egger, N. Kuster, Automated E-field scanning system for dosimetric assessments, IEEE Transaction on Microwave Theory and Techniques, vol. 44, Jan. 1996, pp. 105-113.
- [8] K. Pokovic, T. Schmid, N. Kuster, Robust setup for precise calibration of E-field probes in tissue simulating liquids at mobile communications frequencies, ICECOM97, Oct. 1997, pp. 120-124.
- [9] K. Pokovic, T. Schmid, and N. Kuster, E-field Probe with improved isotropy in brain simulating liquids, Proceedings of the ELMAR, Zadar, Croatia, June 23-25, 1996, pp. 172-175.
- [10] Schmid & Partner Engineering AG, Application Note: Data Storage and Evaluation, June 1998, p2.
- [11] V. Hombach, K. Meier, M. Burkhardt, E. Kuhn, N. Kuster, The Dependence of EM Energy Absorption upon Human Head Modeling at 900 MHz, IEEE Transaction on Microwave Theory and Techniques, vol. 44 no. 10, Oct. 1996, pp. 1865-1873.
- [12] N. Kuster and Q. Balzano, Energy absorption mechanism by biological bodies in the near field of dipole antennas above 300MHz, IEEE Transaction on Vehicular Technology, vol. 41, no. 1, Feb. 1992, pp. 17-23.
- [13] G. Hartsgrrove, A. Kraszewski, A. Surowiec, Simulated Biological Materials for Electromagnetic Radiation Absorption Studies, University of Ottawa, Bioelectromagnetics, Canada: 1987, pp. 29-36.
- [14] Q. Balzano, O. Garay, T. Manning Jr., Electromagnetic Energy Exposure of Simulated Users of Portable Cellular Telephones, IEEE Transactions on Vehicular Technology, vol. 44, no.3, Aug. 1995.
- [15] W. Gander, Computermathematick, Birkhaeuser, Basel, 1992.
- [16] W.H. Press, S.A. Teukolsky, W.T. Vetterling, and B.P. Flannery, Numerical Recipes in C, The Art of Scientific Computing, Second edition, Cambridge University Press, 1992.

FCC ID: A3LSWCU200		CERTIFICATION REPORT		Reviewed by: Quality Manager
SAR Filename: 0810061478.A3L	Test Dates: 11/25/08 - 03/02/09	EUT Type: WiMAX USB Modem		Page 22 of 23

[17] Federal Communications Commission, OET Bulletin 65, Evaluating Compliance with FCC Guidelines for Human Exposure to Radiofrequency Electromagnetic Fields. Supplement C, Dec. 1997.

[18] N. Kuster, R. Kastle, T. Schmid, Dosimetric evaluation of mobile communications equipment with known precision, IEEE Transaction on Communications, vol. E80-B, no. 5, May 1997, pp. 645-652.

[19] CENELEC CLC/SC111B, European Prestandard (prENV 50166-2), Human Exposure to Electromagnetic Fields High-frequency: 10kHz-300GHz, Jan. 1995.

[20] Prof. Dr. Niels Kuster, ETH, Eidgenössische Technische Hochschule Zürich, Dosimetric Evaluation of the Cellular Phone.

[21] FCC SAR Measurement Procedures for 3G Devices v2.0, October 2007

[22] SAR Measurement procedures for IEEE 802.11a/b/g rev 1.2, May 2007

[23] IEC 62209-1, Human exposure to radio frequency fields from hand-held and body-mounted wireless communication devices - Human models, instrumentation, and procedures - Part 1: Procedure to determine the specific absorption rate (SAR) for hand-held devices used in close proximity to the ear (frequency range of 300 MHz to 3 GHz), Feb. 2005.

[24] FCC Public Notice DA-02-1438. Office of Engineering and Technology Announces a Transition Period for the Phantom Requirements of Supplement C to OET Bulletin 65, June 19, 2002

[25] Industry Canada RSS-102 Radio Frequency Exposure Compliance of Radiocommunication Apparatus (All Frequency Bands) Issue 2, November 2005

[26] Health Canada Safety Code 6 Limits of Human Exposure to Radio Frequency Electromagnetic Fields in the Frequency Range from 3 kHz – 300 GHz, 1999



[27] FCC SAR Considerations for Handsets with Multiple Transmitters and Antennas v01r03 #648474, May 2008

[28] FCC Application Note for SAR Probe Calibration and System Verification Consideration for Measurements at 150 MHz – 3 GHz, Rev 1.1, January 2007

[29] FCC SAR Evaluation Considerations for Laptop Computers with Antennas Built-in on Display Screens, v01, December 2007

[30] FCC SAR Measurement Requirements for 3 – 6 GHz Rev1.1, October 2006

[31] FCC Mobile Portable RF Exposure Procedure v03r02 KDB447498, July 2008

FCC ID: A3LSWCU200		CERTIFICATION REPORT		Reviewed by: Quality Manager
SAR Filename: 0810061478.A3L	Test Dates: 11/25/08 - 03/02/09	EUT Type: WiMAX USB Modem		Page 23 of 23

APPENDIX A: SAR TEST DATA

PCTEST ENGINEERING LABORATORY, INC.

DUT: SWC-U200; Type: WiMAX USB Dongle; Serial: FF-211-A

Communication System: WiMAX RF; Frequency: 2501 MHz; Duty Cycle: 1:2.86

Medium: 2501 Muscle ($s = 2.138$ mho/m; $\epsilon_r = 53.25$; $\rho = 1000$ kg/m³)

Phantom section: Flat Section; ; Space: 0.4 cm w/ Laptop

Test Date: 03-02-2009; Ambient Temp: 22.3°C; Tissue Temp: 21.7°C

Probe: EX3DV4 - SN3589; ConvF(6.24, 6.24, 6.24); Calibrated: 6/26/2008

Sensor-Surface: 3mm (Mechanical Surface Detection)

Electronics: DAE4 Sn704; Calibrated: 6/26/2008

Phantom: SAM Sub; Type: SAM 4.0; Serial: TP-1403

Measurement SW: DASY4, V4.7 Build 71; Postprocessing SW: SEMCAD, V1.8 Build 172

Mode: WiMAX, Body SAR, Horizontal 1, Low.ch, BAMCQPSK, 512 FFT, 5 MHz BW

Area Scan (5x6x1): Measurement grid: dx=15mm, dy=15mm

Zoom Scan (7x7x7)/Cube 0: Measurement grid: dx=5mm, dy=5mm, dz=5mm

Reference Value = 15.4 V/m

Peak SAR (extrapolated) = 0.932 W/kg

SAR(1 g) = 0.453 mW/g; SAR(10 g) = 0.235 mW/g

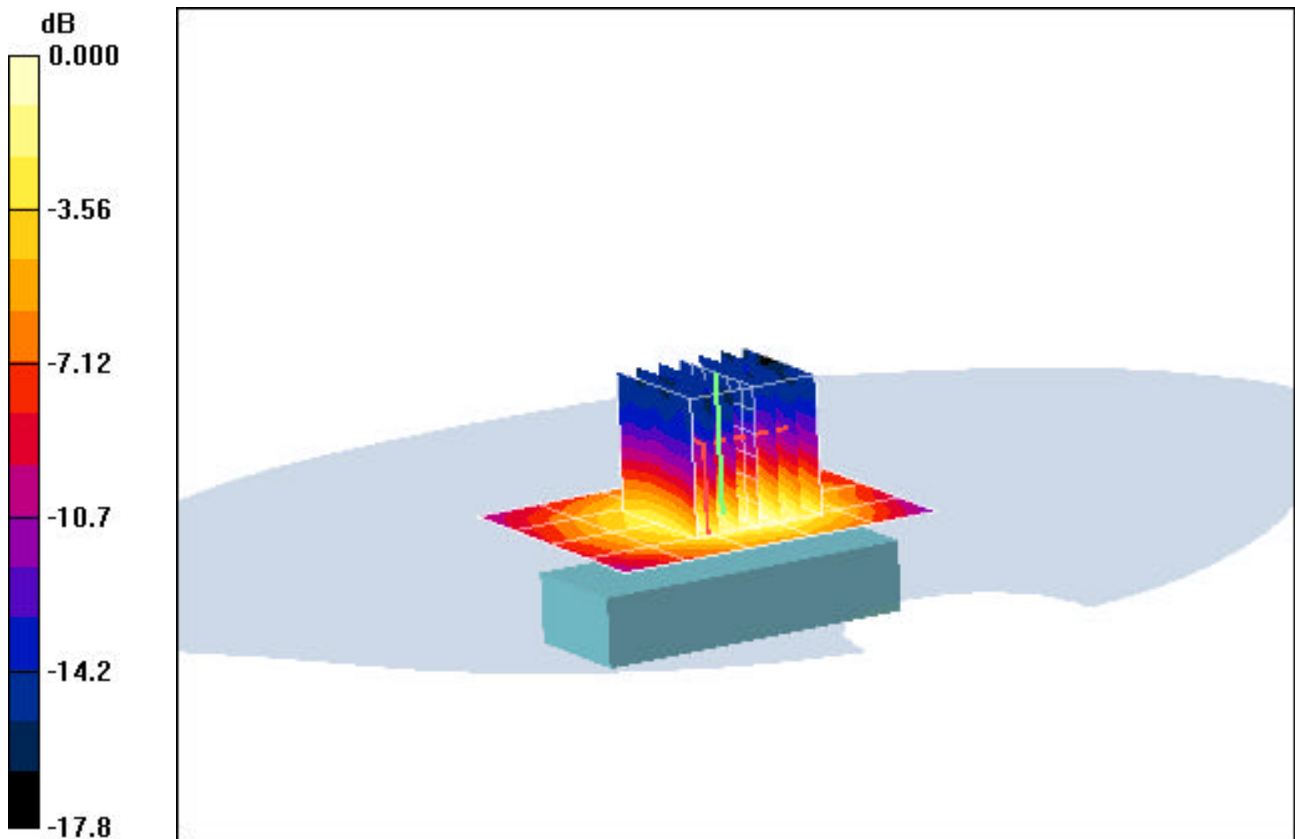

0 dB = 0.566mW/g

PCTEST ENGINEERING LABORATORY, INC.

DUT: SWC-U200; Type: WiMAX USB Dongle; Serial: FF-211-A

Communication System: WiMAX RF; Frequency: 2501 MHz; Duty Cycle: 1:2.86

Medium: 2501 Muscle ($\sigma = 2.11$ mho/m, $\epsilon_r = 51.19$, $\rho = 1000$ kg/m³)

Phantom section: Flat Section; Space: 0.5 cm (Hinge), 0.10 cm (Distal End)

Test Date: 11-25-2008; Ambient Temp: 22.7°C; Tissue Temp: 21.6°C

Probe: EX3DV4 - SN3589; ConvF(6.24, 6.24, 6.24); Calibrated: 6/26/2008

Sensor-Surface: 3mm (Mechanical Surface Detection)

Electronics: DAE4 Sn704; Calibrated: 6/26/2008

Phantom: SAM Main; Type: SAM 4.0; Serial: TP-1406

Measurement SW: DASY4, V4.7 Build 71; Postprocessing SW: SEMCAD, V1.8 Build 172

Mode: WiMAX, Body SAR, Horizontal 2, Low.ch, BAMC QPSK 3/4, 1024P, 10 MHz

Area Scan (6x7x1): Measurement grid: dx=15mm, dy=15mm

Zoom Scan (5x5x7)/Cube 0: Measurement grid: dx=8mm, dy=8mm, dz=5mm

Reference Value = 1.53 V/m

Peak SAR (extrapolated) = 2.04 W/kg

SAR(1 g) = 0.967 mW/g; SAR(10 g) = 0.486 mW/g

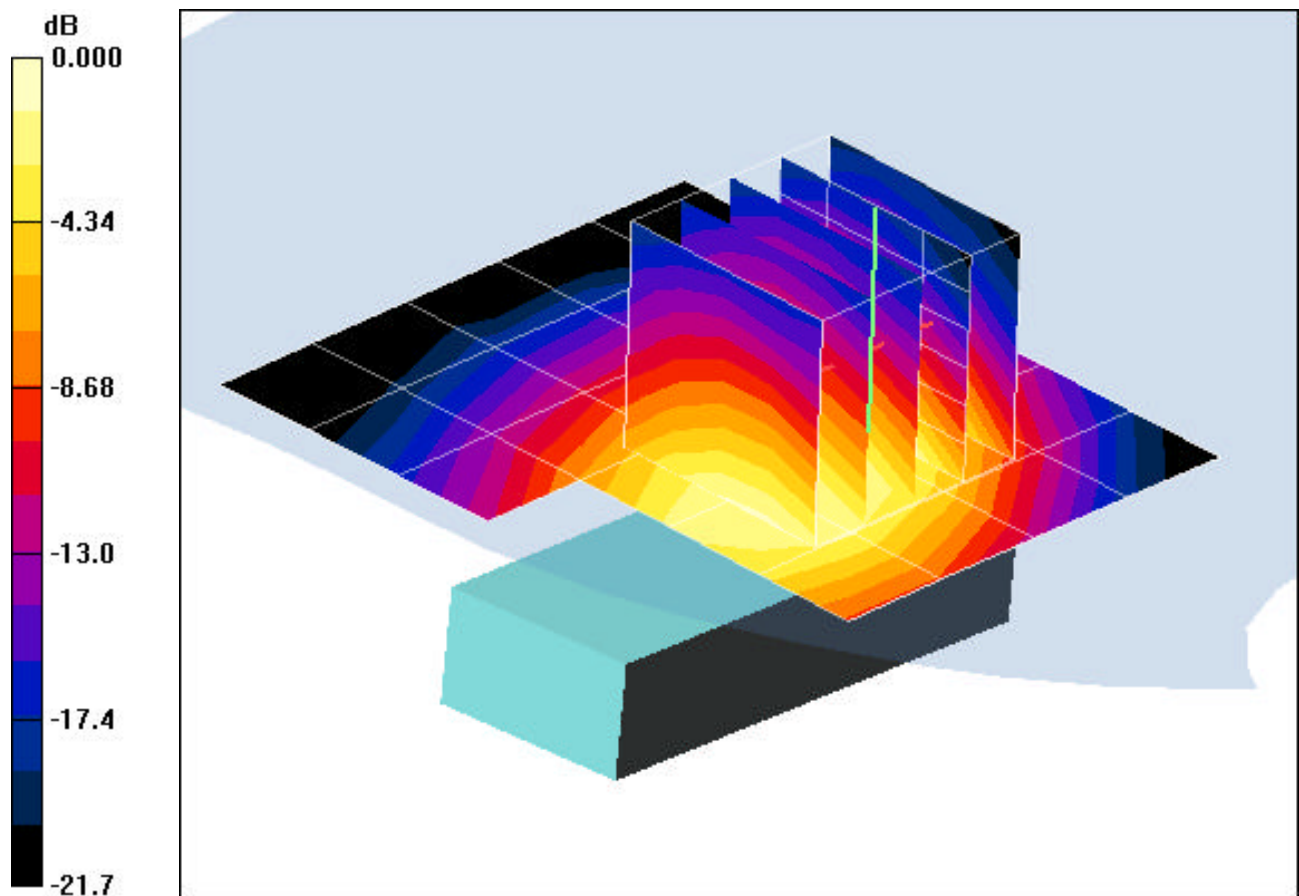

0 dB = 1.19mW/g

PCTEST ENGINEERING LABORATORY, INC.

DUT: SWC-U200; Type: WiMAX USB Dongle; Serial: FF-211-A

Communication System: WiMAX RF; Frequency: 2501 MHz; Duty Cycle: 1:2.86

Medium: 2501 Muscle ($\sigma = 2.138$ mho/m, $\epsilon_r = 53.25$, $\rho = 1000$ kg/m³)

Phantom section: Flat Section; Space: 0.5 mm w/ Laptop

Test Date: 03-02-2009; Ambient Temp: 22.3°C; Tissue Temp: 21.7°C

Probe: EX3DV4 - SN3589; ConvF(6.24, 6.24, 6.24); Calibrated: 6/26/2008

Sensor-Surface: 3mm (Mechanical Surface Detection)

Electronics: DAE4 Sn704; Calibrated: 6/26/2008

Phantom: SAM Sub; Type: SAM 4.0; Serial: TP-1403

Measurement SW: DASY4, V4.7 Build 71; Postprocessing SW: SEMCAD, V1.8 Build 172

Mode: WiMAX, Body SAR, Vertical 3, Low.ch, BAMCQPSK, 1024 FFT, 10 MHz BW

Area Scan (5x6x1): Measurement grid: dx=15mm, dy=15mm

Zoom Scan (7x7x7)/Cube 0: Measurement grid: dx=5mm, dy=5mm, dz=5mm

Reference Value = 25.0 V/m

Peak SAR (extrapolated) = 3.04 W/kg

SAR(1 g) = 1.18 mW/g; SAR(10 g) = 0.503 mW/g

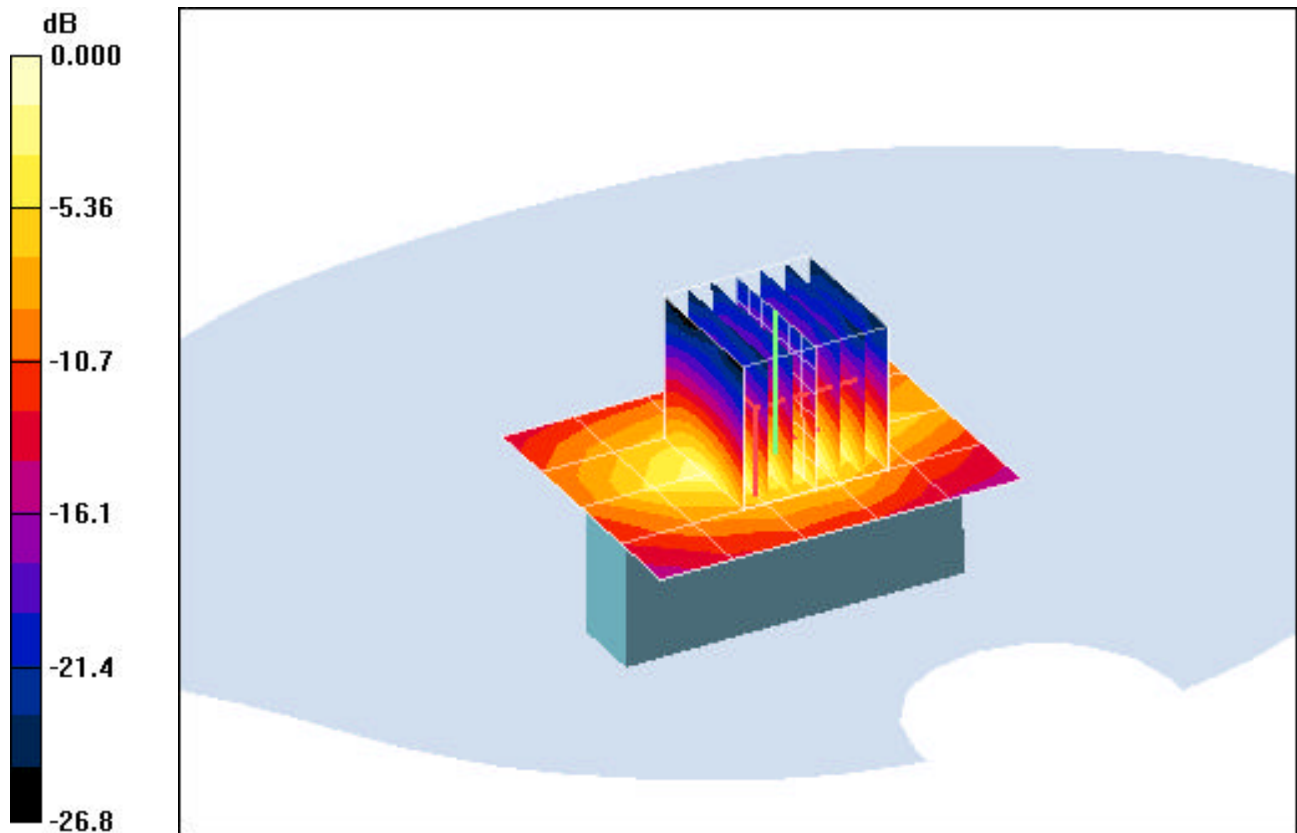

0 dB = 1.55mW/g

PCTEST ENGINEERING LABORATORY, INC.

DUT: SWC-U200; Type: WiMAX USB Dongle; Serial: FF-211-A

Communication System: WiMAX RF; Frequency: 2501 MHz; Duty Cycle: 1:2.86

Medium: 2501 Muscle ($\sigma = 2.11$ mho/m, $\epsilon_r = 51.19$, $\rho = 1000$ kg/m³)

Phantom section: Flat Section; Space: 0.5 cm

Test Date: 11-25-2008; Ambient Temp: 22.7°C; Tissue Temp: 21.6°C

Probe: EX3DV4 - SN3589; ConvF(6.24, 6.24, 6.24); Calibrated: 6/26/2008

Sensor-Surface: 3mm (Mechanical Surface Detection)

Electronics: DAE4 Sn704; Calibrated: 6/26/2008

Phantom: SAM Main; Type: SAM 4.0; Serial: TP-1406

Measurement SW: DASY4, V4.7 Build 71; Postprocessing SW: SEMCAD, V1.8 Build 172

Mode: WiMAX, Body SAR, Vertical 4, Low.ch, BAMC QPSK 3/4, 1024P, 10 MHz

Area Scan (5x6x1): Measurement grid: dx=15mm, dy=15mm

Zoom Scan (5x5x7)/Cube 0: Measurement grid: dx=8mm, dy=8mm, dz=5mm

Reference Value = 22.4 V/m

Peak SAR (extrapolated) = 1.87 W/kg

SAR(1 g) = 0.930 mW/g; SAR(10 g) = 0.440 mW/g

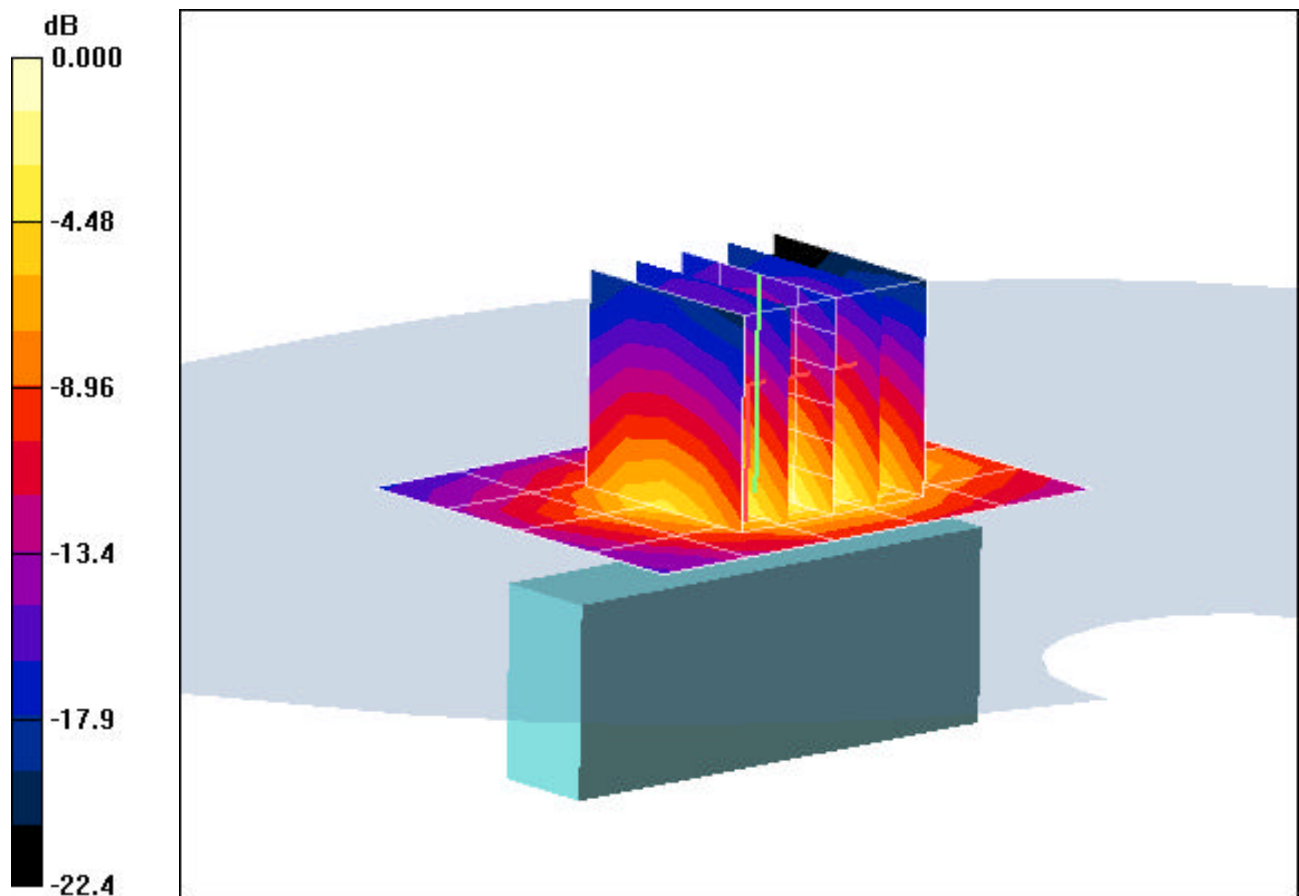

0 dB = 1.22mW/g

PCTEST ENGINEERING LABORATORY, INC.

DUT: SWC-U200; Type: WiMAX USB Dongle; Serial: FF-211-A

Communication System: WiMAX RF; Frequency: 2501 MHz; Duty Cycle: 1:2.86

Medium: 2501 Muscle ($\sigma = 2.11$ mho/m, $\epsilon_r = 51.19$, $\rho = 1000$ kg/m³)

Phantom section: Flat Section; Space: 0.5 cm

Test Date: 11-25-2008; Ambient Temp: 22.7°C; Tissue Temp: 21.6°C

Probe: EX3DV4 - SN3589; ConvF(6.24, 6.24, 6.24); Calibrated: 6/26/2008

Sensor-Surface: 3mm (Mechanical Surface Detection)

Electronics: DAE4 Sn704; Calibrated: 6/26/2008

Phantom: SAM Main; Type: SAM 4.0; Serial: TP-1406

Measurement SW: DASY4, V4.7 Build 71; Postprocessing SW: SEMCAD, V1.8 Build 172

Mode: WiMAX, Body SAR, Back side, Low.ch, BAMC QPSK 3/4, 1024P, 10MHz

Area Scan (5x6x1): Measurement grid: dx=15mm, dy=15mm

Zoom Scan (5x5x7)/Cube 0: Measurement grid: dx=8mm, dy=8mm, dz=5mm

Reference Value = 16.4 V/m

Peak SAR (extrapolated) = 1.13 W/kg

SAR(1 g) = 0.531 mW/g; SAR(10 g) = 0.243 mW/g

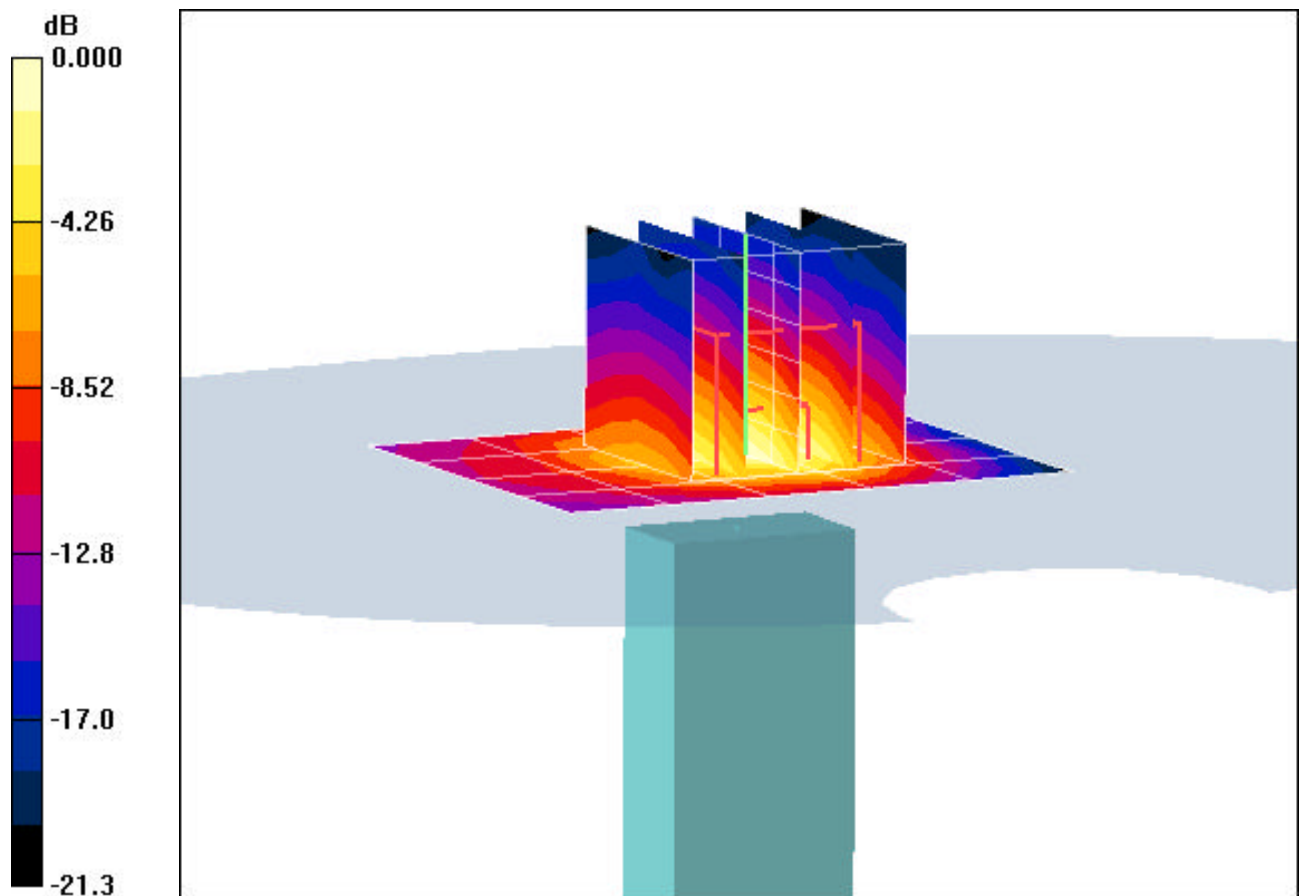

0 dB = 0.685mW/g

PCTEST ENGINEERING LABORATORY, INC.

DUT: SWC-U200; Type: WiMAX USB Dongle; Serial: FF-211-A

Communication System: WiMAX RF; Frequency: 2501 MHz; Duty Cycle: 1:2.86

Medium: 2501 Muscle ($\sigma = 2.138$ mho/m, $\epsilon_r = 53.25$, $\rho = 1000$ kg/m³)

Phantom section: Flat Section; Space: 0.5 mm w/ Laptop

Test Date: 03-02-2009; Ambient Temp: 22.3°C; Tissue Temp: 21.7°C

Probe: EX3DV4 - SN3589; ConvF(6.24, 6.24, 6.24); Calibrated: 6/26/2008

Sensor-Surface: 3mm (Mechanical Surface Detection)

Electronics: DAE4 Sn704; Calibrated: 6/26/2008

Phantom: SAM Sub; Type: SAM 4.0; Serial: TP-1403

Measurement SW: DASY4, V4.7 Build 71; Postprocessing SW: SEMCAD, V1.8 Build 172

Mode: WiMAX, Body SAR, Vertical 3, Low.ch, BAMCQPSK, 1024 FFT, 10 MHz BW

Area Scan (5x6x1): Measurement grid: dx=15mm, dy=15mm

Zoom Scan (7x7x7)/Cube 0: Measurement grid: dx=5mm, dy=5mm, dz=5mm

Reference Value = 25.0 V/m

Peak SAR (extrapolated) = 3.04 W/kg

SAR(1 g) = 1.18 mW/g; SAR(10 g) = 0.503 mW/g

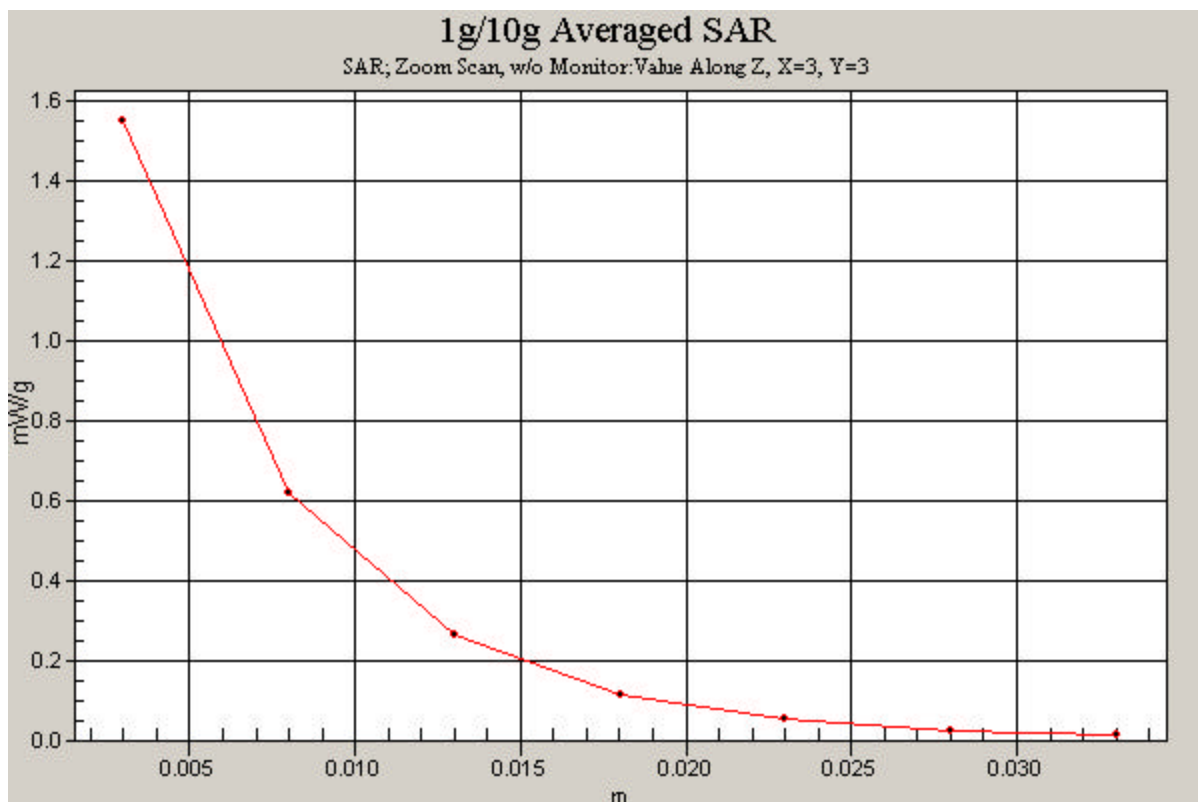

APPENDIX B: DIPOLE VALIDATION

PCTEST ENGINEERING LABORATORY, INC.

DUT: SAR Dipole 2600 MHz; Type: D2600V2; Serial: 1004

Communication System: WiMAX RF; Frequency: 2600 MHz; Duty Cycle: 1:1

Medium: 2600 Muscle ($\sigma = 2.25$ mho/m, $\epsilon_r = 50.63$, $\rho = 1000$ kg/m³)

Phantom section: Flat Section; Space: 1.0 cm

Test Date: 11-25-2008; Ambient Temp: 22.7°C; Tissue Temp: 21.6°C

Probe: EX3DV4 - SN3589; ConvF(6.24, 6.24, 6.24); Calibrated: 6/26/2008

Sensor-Surface: 3mm (Mechanical Surface Detection)

Electronics: DAE4 Sn704; Calibrated: 6/26/2008

Phantom: SAM Main; Type: SAM 4.0; Serial: TP-1406

Measurement SW: DASY4, V4.7 Build 71; Postprocessing SW: SEMCAD, V1.8 Build 172

2600MHz Dipole Validation

Area Scan (6x7x1): Measurement grid: dx=15mm, dy=15mm

Zoom Scan (7x7x7)/Cube 0: Measurement grid: dx=5mm, dy=5mm, dz=5mm

Input Power = 20.0 dBm (100 mW)

SAR(1 g) = 6.22 mW/g; SAR(10 g) = 2.83 mW/g

Deviation = 6.51 %

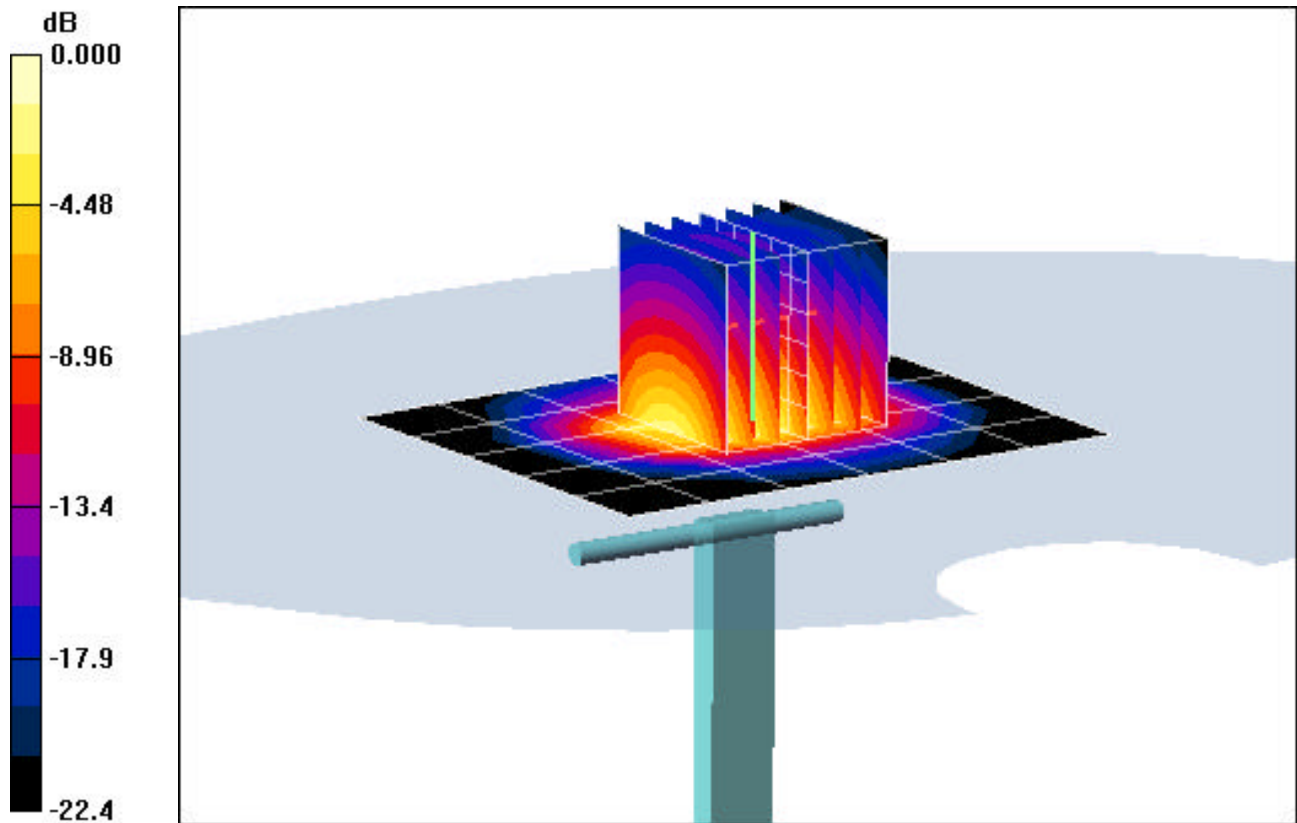

0 dB = 8.09mW/g

PCTEST ENGINEERING LABORATORY, INC.

DUT: SAR Dipole 2600 MHz; Type: D2600V2; Serial: 1004

Communication System: WiMAX RF; Frequency: 2600 MHz; Duty Cycle: 1:1

Medium: 2501 Muscle ($\sigma = 2.138$ mho/m, $\epsilon_r = 53.25$, $\rho = 1000$ kg/m³)

Phantom section: Flat Section; Space: 1.0 cm

Test Date: 03-02-2009; Ambient Temp: 22.3°C; Tissue Temp: 21.7°C

Probe: EX3DV4 - SN3589; ConvF(6.24, 6.24, 6.24); Calibrated: 6/26/2008

Sensor-Surface: 3mm (Mechanical Surface Detection)

Electronics: DAE4 Sn704; Calibrated: 6/26/2008

Phantom: SAM Sub; Type: SAM 4.0; Serial: TP-1403

Measurement SW: DASY4, V4.7 Build 71; Postprocessing SW: SEMCAD, V1.8 Build 172

2600MHz Dipole Validation

Area Scan (5x6x1): Measurement grid: dx=15mm, dy=15mm

Zoom Scan (7x7x7)/Cube 0: Measurement grid: dx=5mm, dy=5mm, dz=5mm

Input Power = 20.0 dBm (100 mW)

SAR(1 g) = 5.87 mW/g; SAR(10 g) = 2.67 mW/g

Deviation = 0.51 %

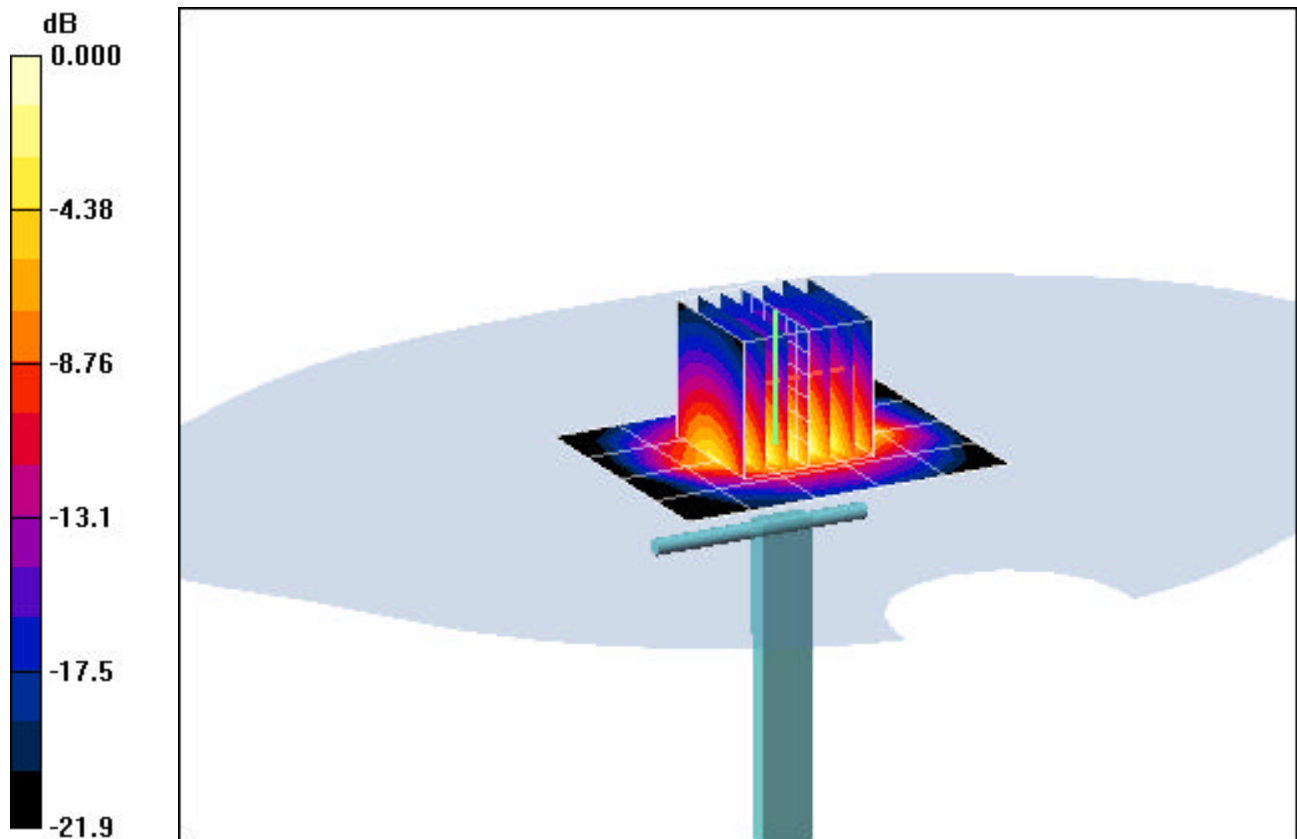

0 dB = 7.71mW/g

APPENDIX C: PROBE CALIBRATION



Accredited by the Swiss Accreditation Service (SAS)
The Swiss Accreditation Service is one of the signatories to the EA
Multilateral Agreement for the recognition of calibration certificates

Accreditation No.: **SCS 108**

Client **PC Test**

Certificate No: **EX3-3589_Jun08**

CALIBRATION CERTIFICATE

Object **EX3DV4 - SN:3589**

Calibration procedure(s) **QA CAL-01.v6, QA CAL-14.v3 and QA CAL-23.v3
Calibration procedure for dosimetric E-field probes**

Calibration date: **June 26, 2008**

Condition of the calibrated item **In Tolerance**

This calibration certificate documents the traceability to national standards, which realize the physical units of measurements (SI).
The measurements and the uncertainties with confidence probability are given on the following pages and are part of the certificate.

All calibrations have been conducted in the closed laboratory facility: environment temperature (22 ± 3)°C and humidity < 70%.

Calibration Equipment used (M&TE critical for calibration)

Primary Standards	ID #	Cal Date (Certificate No.)	Scheduled Calibration
Power meter E4419B	GB41293874	1-Apr-08 (No. 217-00788)	Apr-09
Power sensor E4412A	MY41495277	1-Apr-08 (No. 217-00788)	Apr-09
Power sensor E4412A	MY41498087	1-Apr-08 (No. 217-00788)	Apr-09
Reference 3 dB Attenuator	SN: S5054 (3c)	8-Aug-07 (No. 217-00719)	Aug-08
Reference 20 dB Attenuator	SN: S5086 (20b)	31-Mar-08 (No. 217-00787)	Apr-09
Reference 30 dB Attenuator	SN: S5129 (30b)	8-Aug-07 (No. 217-00720)	Aug-08
Reference Probe ES3DV2	SN: 3013	2-Jan-08 (No. ES3-3013_Jan08)	Jan-09
DAE4	SN: 660	3-Sep-07 (No. DAE4-660_Sep07)	Sep-08

Secondary Standards	ID #	Check Date (in house)	Scheduled Check
RF generator HP 8648C	US3642U01700	4-Aug-99 (in house check Oct-07)	In house check: Oct-09
Network Analyzer HP 8753E	US37390585	18-Oct-01 (in house check Oct-07)	In house check: Oct-08

	Name	Function	Signature
Calibrated by:	Katja Pokovic	Technical Manager	
Approved by:	Niels Kuster	Quality Manager	

Issued: June 26, 2008

This calibration certificate shall not be reproduced except in full without written approval of the laboratory.



Accredited by the Swiss Accreditation Service (SAS)
The Swiss Accreditation Service is one of the signatories to the EA
Multilateral Agreement for the recognition of calibration certificates

Accreditation No.: **SCS 108**

Glossary:

TSL	tissue simulating liquid
NORM _{x,y,z}	sensitivity in free space
ConvF	sensitivity in TSL / NORM _{x,y,z}
DCP	diode compression point
Polarization φ	φ rotation around probe axis
Polarization ϑ	ϑ rotation around an axis that is in the plane normal to probe axis (at measurement center), i.e., $\vartheta = 0$ is normal to probe axis

Calibration is Performed According to the Following Standards:

- IEEE Std 1528-2003, "IEEE Recommended Practice for Determining the Peak Spatial-Averaged Specific Absorption Rate (SAR) in the Human Head from Wireless Communications Devices: Measurement Techniques", December 2003
- IEC 62209-1, "Procedure to measure the Specific Absorption Rate (SAR) for hand-held devices used in close proximity to the ear (frequency range of 300 MHz to 3 GHz)", February 2005

Methods Applied and Interpretation of Parameters:

- NORM_{x,y,z}**: Assessed for E-field polarization $\vartheta = 0$ ($f \leq 900$ MHz in TEM-cell; $f > 1800$ MHz: R22 waveguide). NORM_{x,y,z} are only intermediate values, i.e., the uncertainties of NORM_{x,y,z} does not effect the E²-field uncertainty inside TSL (see below *ConvF*).
- NORM(*f*)_{x,y,z}** = NORM_{x,y,z} * *frequency_response* (see Frequency Response Chart). This linearization is implemented in DASY4 software versions later than 4.2. The uncertainty of the frequency response is included in the stated uncertainty of *ConvF*.
- DCP_{x,y,z}**: DCP are numerical linearization parameters assessed based on the data of power sweep (no uncertainty required). DCP does not depend on frequency nor media.
- ConvF and Boundary Effect Parameters**: Assessed in flat phantom using E-field (or Temperature Transfer Standard for $f \leq 800$ MHz) and inside waveguide using analytical field distributions based on power measurements for $f > 800$ MHz. The same setups are used for assessment of the parameters applied for boundary compensation (alpha, depth) of which typical uncertainty values are given. These parameters are used in DASY4 software to improve probe accuracy close to the boundary. The sensitivity in TSL corresponds to NORM_{x,y,z} * *ConvF* whereby the uncertainty corresponds to that given for *ConvF*. A frequency dependent *ConvF* is used in DASY version 4.4 and higher which allows extending the validity from ± 50 MHz to ± 100 MHz.
- Spherical isotropy (3D deviation from isotropy)**: in a field of low gradients realized using a flat phantom exposed by a patch antenna.
- Sensor Offset**: The sensor offset corresponds to the offset of virtual measurement center from the probe tip (on probe axis). No tolerance required.

Probe EX3DV4

SN:3589

Manufactured:	March 30, 2006
Last calibrated:	May 28, 2007
Recalibrated:	June 26, 2008

Calibrated for DASYS Systems

(Note: non-compatible with DASYS2 system!)

DASY - Parameters of Probe: EX3DV4 SN:3589

Sensitivity in Free Space^A

NormX	0.47 ± 10.1%	$\mu\text{V}/(\text{V}/\text{m})^2$	DCP X	96 mV
NormY	0.38 ± 10.1%	$\mu\text{V}/(\text{V}/\text{m})^2$	DCP Y	96 mV
NormZ	0.37 ± 10.1%	$\mu\text{V}/(\text{V}/\text{m})^2$	DCP Z	96 mV

Diode Compression^B

Sensitivity in Tissue Simulating Liquid (Conversion Factors)

Please see Page 8.

Boundary Effect

TSL 900 MHz Typical SAR gradient: 5 % per mm

		2.0 mm	3.0 mm
Sensor Center to Phantom Surface Distance			
SAR _{be} [%]	Without Correction Algorithm	10.3	5.7
SAR _{be} [%]	With Correction Algorithm	0.8	0.5

TSL 1810 MHz Typical SAR gradient: 10 % per mm

		2.0 mm	3.0 mm
Sensor Center to Phantom Surface Distance			
SAR _{be} [%]	Without Correction Algorithm	7.7	3.6
SAR _{be} [%]	With Correction Algorithm	0.3	0.3

Sensor Offset

Probe Tip to Sensor Center **1.0 mm**

The reported uncertainty of measurement is stated as the standard uncertainty of measurement multiplied by the coverage factor k=2, which for a normal distribution corresponds to a coverage probability of approximately 95%.

^A The uncertainties of NormX,Y,Z do not affect the E²-field uncertainty inside TSL (see Page 8).

^B Numerical linearization parameter: uncertainty not required.

Frequency Response of E-Field

(TEM-Cell:ifi110 EXX, Waveguide: R22)

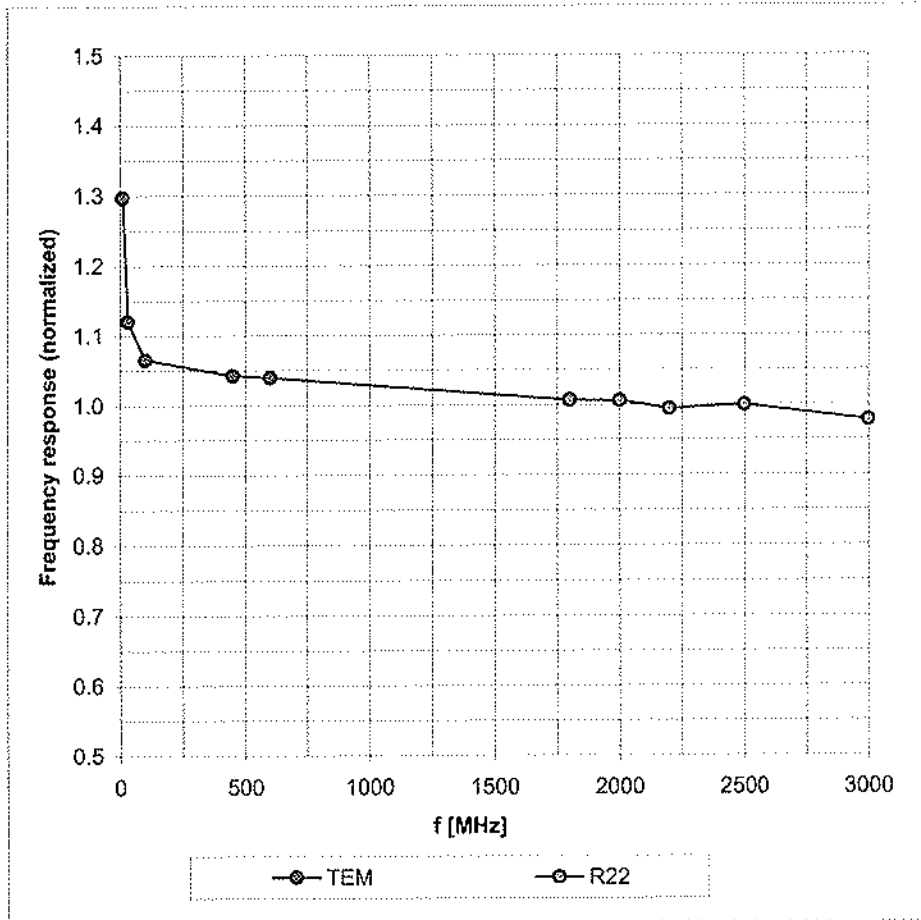

Uncertainty of Frequency Response of E-field: $\pm 6.3\%$ (k=2)

Receiving Pattern (ϕ), $\vartheta = 0^\circ$

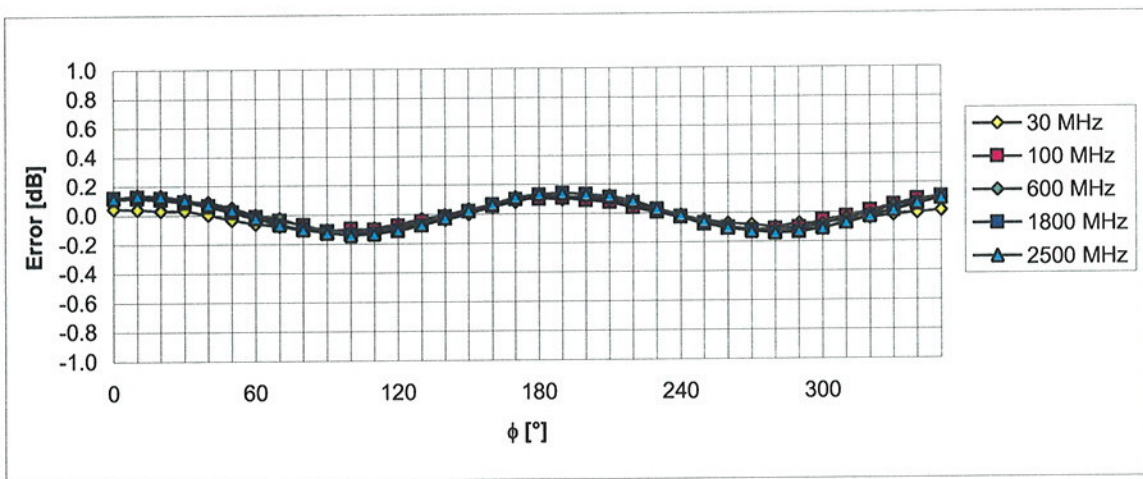
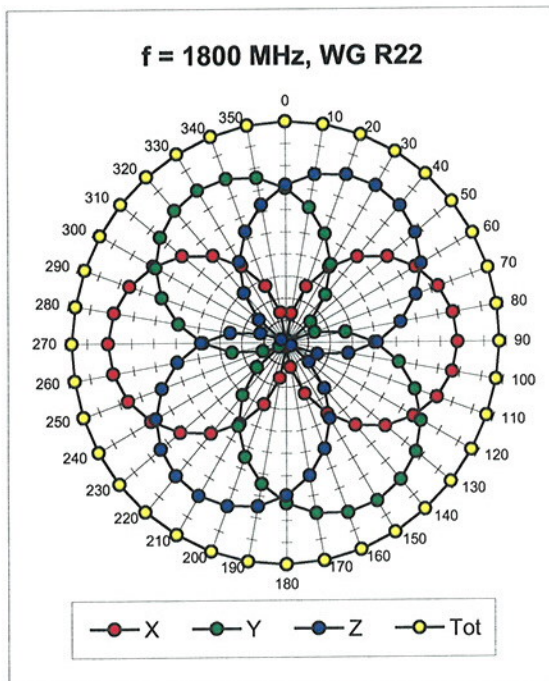
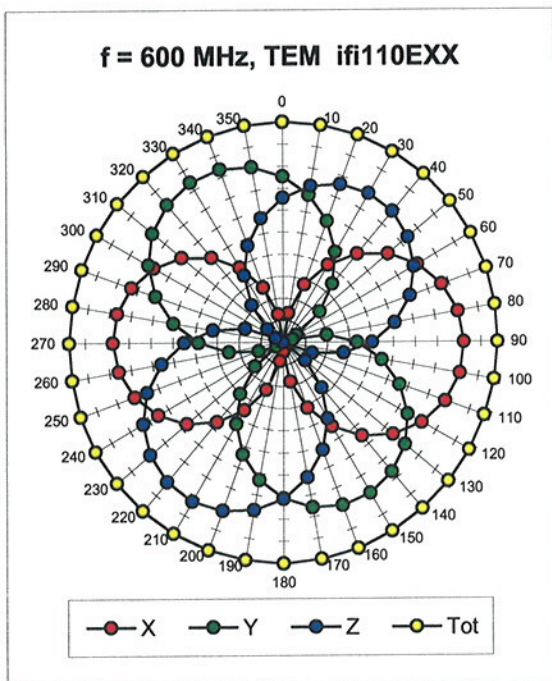

Uncertainty of Axial Isotropy Assessment: $\pm 0.5\%$ (k=2)

Dynamic Range $f(\text{SAR}_{\text{head}})$ (Waveguide R22, $f = 1800 \text{ MHz}$)

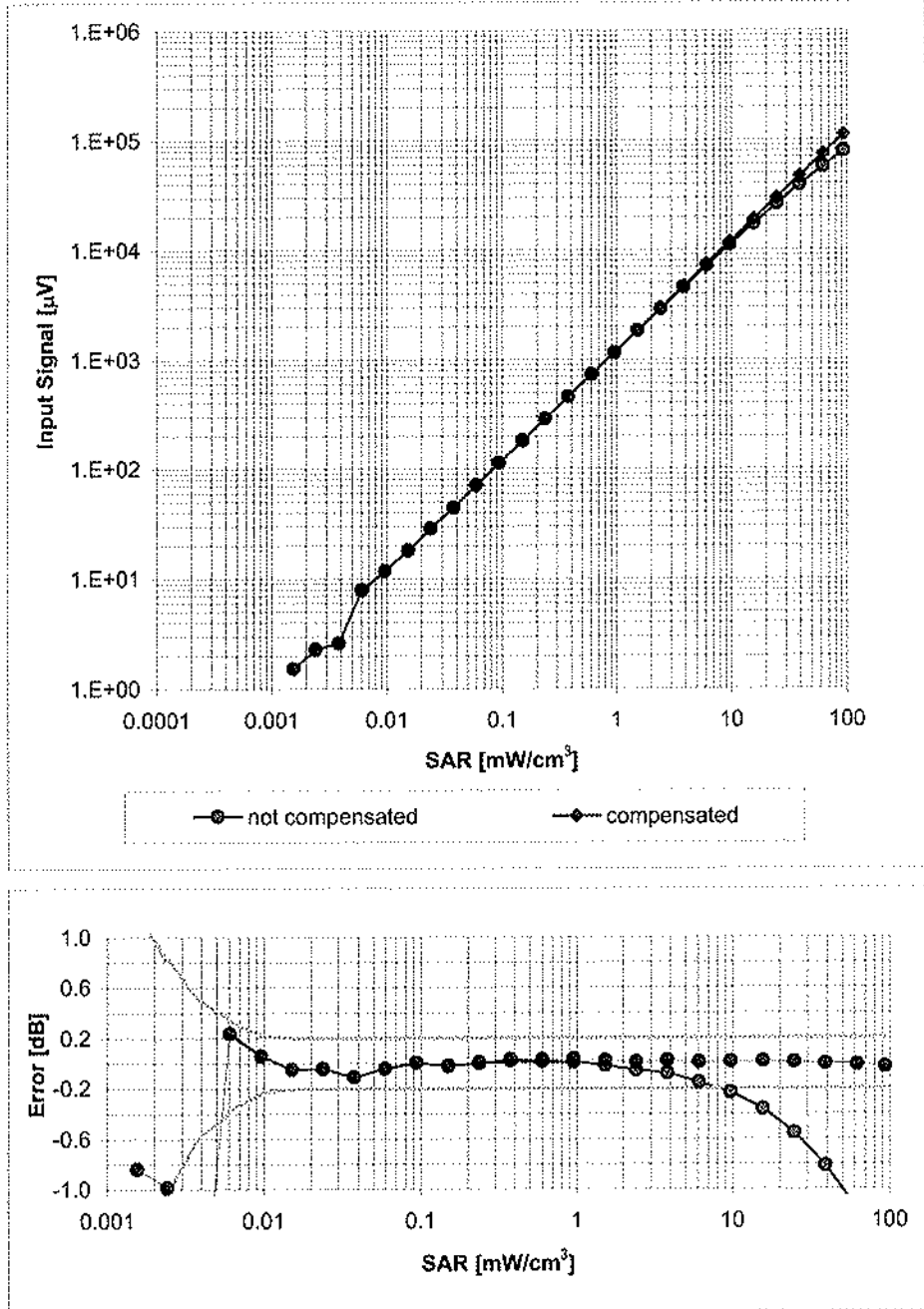

Uncertainty of Linearity Assessment: $\pm 0.6\%$ ($k=2$)

Conversion Factor Assessment

f [MHz]	Validity [MHz] ^c	TSL	Permittivity	Conductivity	Alpha	Depth	ConvF Uncertainty
835	± 50 / ± 100	Head	41.5 ± 5%	0.90 ± 5%	0.81	0.67	8.33 ± 11.0% (k=2)
1810	± 50 / ± 100	Head	40.0 ± 5%	1.40 ± 5%	0.51	0.70	7.50 ± 11.0% (k=2)
2300	± 50 / ± 100	Head	39.4 ± 5%	1.71 ± 5%	0.47	0.72	6.85 ± 11.0% (k=2)
2450	± 50 / ± 100	Head	39.2 ± 5%	1.80 ± 5%	0.69	0.61	6.58 ± 11.0% (k=2)
2600	± 50 / ± 100	Head	39.0 ± 5%	1.96 ± 5%	0.36	0.83	6.51 ± 11.0% (k=2)
4950	± 50 / ± 100	Head	36.3 ± 5%	4.40 ± 5%	0.30	1.70	4.72 ± 13.1% (k=2)
5200	± 50 / ± 100	Head	36.0 ± 5%	4.66 ± 5%	0.33	1.75	4.67 ± 13.1% (k=2)
5300	± 50 / ± 100	Head	35.9 ± 5%	4.76 ± 5%	0.36	1.75	4.51 ± 13.1% (k=2)
5500	± 50 / ± 100	Head	35.6 ± 5%	4.96 ± 5%	0.38	1.75	4.42 ± 13.1% (k=2)
5600	± 50 / ± 100	Head	35.5 ± 5%	5.07 ± 5%	0.38	1.75	4.45 ± 13.1% (k=2)
5800	± 50 / ± 100	Head	35.3 ± 5%	5.27 ± 5%	0.38	1.75	4.40 ± 13.1% (k=2)
835	± 50 / ± 100	Body	55.2 ± 5%	0.97 ± 5%	0.75	0.68	8.32 ± 11.0% (k=2)
1810	± 50 / ± 100	Body	53.3 ± 5%	1.52 ± 5%	0.43	0.78	6.88 ± 11.0% (k=2)
2300	± 50 / ± 100	Body	52.8 ± 5%	1.85 ± 5%	0.43	0.88	6.51 ± 11.0% (k=2)
2450	± 50 / ± 100	Body	52.7 ± 5%	1.95 ± 5%	0.46	0.86	6.27 ± 11.0% (k=2)
2600	± 50 / ± 100	Body	52.5 ± 5%	2.16 ± 5%	0.64	0.69	6.24 ± 11.0% (k=2)
4950	± 50 / ± 100	Body	49.4 ± 5%	5.01 ± 5%	0.35	1.75	4.09 ± 13.1% (k=2)
5200	± 50 / ± 100	Body	49.0 ± 5%	5.30 ± 5%	0.34	1.75	4.16 ± 13.1% (k=2)
5300	± 50 / ± 100	Body	48.5 ± 5%	5.42 ± 5%	0.42	1.75	3.86 ± 13.1% (k=2)
5500	± 50 / ± 100	Body	48.6 ± 5%	5.65 ± 5%	0.38	1.75	4.13 ± 13.1% (k=2)
5600	± 50 / ± 100	Body	48.5 ± 5%	5.77 ± 5%	0.28	1.75	4.22 ± 13.1% (k=2)
5800	± 50 / ± 100	Body	48.2 ± 5%	6.00 ± 5%	0.38	1.75	4.09 ± 13.1% (k=2)

^c The validity of ± 100 MHz only applies for DASY v4.4 and higher (see Page 2). The uncertainty is the RSS of the ConvF uncertainty at calibration frequency and the uncertainty for the indicated frequency band.

Deviation from Isotropy in HSL

Error (ϕ , ϑ), $f = 900$ MHz

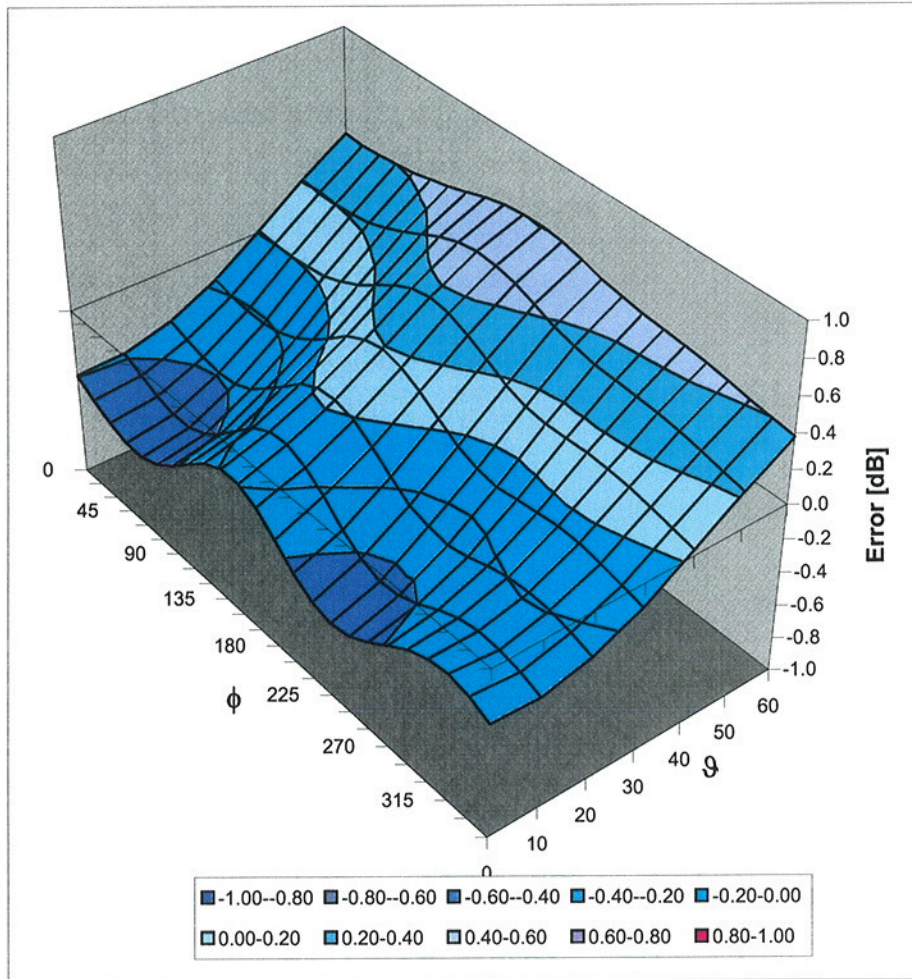

Uncertainty of Spherical Isotropy Assessment: $\pm 2.6\%$ ($k=2$)