



Nemko Korea CO., Ltd.

300-2, Osan-Ri, Mohyeon-Myeon, Cheoin-Gu, Yongin-Si, Gyeonggi-Do, KOREA

TEL:+82 31 322 2333 FAX:+82 31 322 2332

FCC and IC EVALUATION REPORT FOR CERTIFICATION

Applicant :

Samsung Electronics Co., Ltd.
416, Maetan-3Dong, Yeongtong-Gu,
Suwon-Si, Gyeonggi-Do, Korea.
(Post code : 443-742)
Attn. : Mr. Jay-woo, Lee

Dates of Issue : January 14, 2011
Test Report No. : NK-10-R-362
Test Site : Nemko Korea Co., Ltd.

FCC ID
IC ID

Brand Name

Contact Person

<p>A3LSSG3100GB 649E-SSG3100GB</p> <p>SAMSUNG</p> <p>Samsung Electronics Co., Ltd. 416, Maetan-3Dong, Yeongtong-Gu, Suwon-Si, Gyeonggi-Do, Korea, 442-742. Mr. Jaywoo. Lee Telephone No. : +82-31-277-2569</p>
--

Applied Standard: FCC 47 CFR Part 15C and IC RSS-210
Classification: Digital transmission system
EUT Type: 3D Active Glasses

The device bearing the brand name and model specified above has been shown to comply with the applicable technical standards as indicated in the measurement report and was tested in accordance with the measurement procedures specified in ANSI C63.4-2003. The client should not use it to claim product endorsement by TAF or any government agencies. The test results in the report only apply to the tested sample.

I attest to the accuracy of data and all measurements reported herein were performed by me or were made under my supervision and are correct to the best of my knowledge and belief. I assume full responsibility for the completeness of these measurements and vouch for the qualifications of all persons taking them.

Jan 14. 2011
Tested By : Jin-Ha, Ko
Engineer



Jan. 14. 2011
Reviewed By : H.H. Kim
Manager & Chief Engineer

TABLE OF CONTENTS

1. Scope	4
2. Introduction (Site Description)	5
2.1 Test facility	5
2.2 Accreditation and listing	6
3. Test Conditions & EUT Information	7
3.1 Operation During Test	7
3.2 Support Equipment	7
3.3 Setup Drawing	7
3.4 EUT Information	8
4. Summary of Test Results	9
5. Recommendation / Conclusion	10
6. Antenna Requirements	10
7. Description of Test	11
7.1 Conducted Emissions	11
7.2 Radiated Emissions	12
7.3 20 dB Bandwidth and Carrier Frequency Separation	13
7.4 Transmitter Average Time of Occupancy	13
7.5 Number of Hopping Channels	14
7.6 Maximum Peak Output Power	14
7.7 Conducted Spurious Emissions	15
8. Test Data	16
8.1 Radiated Emissions	16
8.2 20 dB Modulated Bandwidth	17
8.3 Carrier Frequency Separation	20
8.4 Transmitter Average Time of Occupancy	22
8.5 Number of Hopping Channels	24

8.6 Peak Power Output	26
8.7 Conducted Spurious Emissions	29
8.8 Radiated Spurious Emissions	34
8.9 Receiver Spurious Emission	38
9. Test Equipment	39
10 Accuracy of Measurement	40
Appendix A: Labelling Requirement	42
Appendix B: Photographs of Test Set-up	43
Appendix C: EUT Photographs	44

1. SCOPE

Measurement and determination of electromagnetic emissions (EME) of radio frequency devices including intentional and/or unintentional radiators for compliance with the technical rules and regulations of the Federal Communications Commission under FCC part 15 and IC RSS-210.

Responsible Party :	Samsung Electronics Co., Ltd.
Contact Person :	Mr. Jaywoo. Lee
Manufacturer :	Samsung Electronics Co., Ltd. 416 Maetan-3Dong, Yeongtong-Gu, Suwon-Si, Gyeonggi-Do, 443-742 KOREA

- FCC ID: A3LSSG3100GB
- Model: SSG-3100GB
- Variant Model: SSG-M3150GB
- Brand Name: SAMSUNG
- EUT Type: 3D Active Glasses
- Classification: FCC Class B
- Applied Standard: FCC 47 CFR Part 15 subpart C and IC RSS-210
- Test Procedure(s): ANSI C63.4 (2003)
- Dates of Test: Nov. 1, 2010 ~ Nov. 10, 2010
- Place of Tests: Nemko Korea Co., Ltd.

2. INTRODUCTION

2.1 Test facility

The measurement procedure described in American National Standard for Methods of Measurement of Radio-Noise Emissions from Low-Voltage Electrical and Electronic Equipment in the Range of 9 kHz to 40 GHz (ANSI C63.4-2003) was used in determining radiated and conducted emissions emanating from **Samsung Electronics Co., Ltd.**

FCC ID : **A3LSSG3100GB** and IC ID : **649E-SSG3100GB**

These measurement tests were conducted at **Nemko Korea Co., Ltd. EMC Laboratory.**

The site address is 300-2, Osan-Ri, Mohyeon-Myeon, Cheoin-Gu, Yongin-Si, Gyeonggi-Do, KOREA.

The area of Nemko Korea Corporation Ltd. EMC Test Site is located in a mountain area at 80 kilo-meters (48 miles) southeast and Incheon International Airport (Incheon Airport), 30 kilometers (18miles) south-southeast from central Seoul.

It is located in the valley surrounded by mountains in all directions where ambient radio signal conditions are quiet and a favorable area to measure the radio frequency interference on open field test site for the computing and ISM devices manufactures.

The detailed description of the measurement facility was found to be in compliance with the requirements of § 2.948 according to ANSI C63.4 2003.

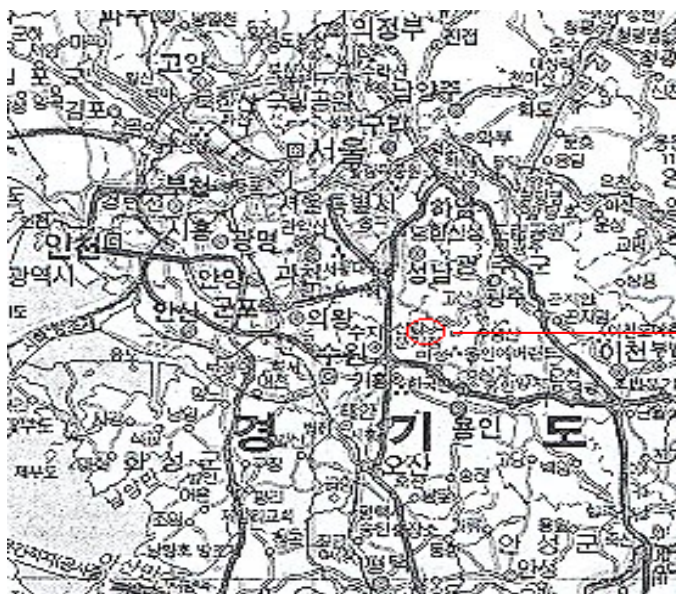

Nemko Korea Co., Ltd.
EMC Lab.
300-2, Osan-Ri, Mohyeon-Myeon,
Cheoin-Gu, Yongin-Si, Gyeonggi-Do,
KOREA 449-852
Tel)+82-31-322-2333

Fig. 1. The map above shows the Seoul in Korea vicinity area.
The map also shows Nemko Korea Corporation Ltd. EMC Lab. and Incheon Airport.

2.2 Accreditation and listing

Accreditation type		Accreditation number
	FCC part 15/18 Filing site	Registration No. 97992
	CAB Accreditation for DOC	Designation No. KR0026
	KOLAS Accredited Lab. (Korea Laboratory Accreditation Scheme)	Registration No. 155
	Canada IC Registered site	Site No. 2040E-1
	VCCI registration site(RE/CE/Telecom CE)	Member No. 2118
	EMC CBTL	-
	KCC(RRL)Designated Lab.	Registration No. KR0026
	SASO registered Lab and Certification Body	Registration No. 2008-15

3. TEST CONDITIONS & EUT INFORMATION

3.1 Operation During Test

The EUT was connected to a laptop computer and operated by internal battery d.c. 3 V. The EUT was measured at three X, Y, Z-Axis in Bluetooth Traffic mode with the maximum output power in accordance with the manufacturer's specifications. The worst data were recorded in the report.

3.2 Support Equipment

Laptop Computer	Dell Inc. Model : PP32LA 0.8 m unshielded USB cable	S/N: N/A
AC/DC Adaptor	DELTA ELECTRONICS(JANG SU), LTD. Model : DA90PE1-00 0.9 m unshielded power cable	FCC DOC S/N: N/A
EUT	Samsung Electronics Co., Ltd. FCC ID : A3LSSG3100GB	S/N: N/A

3.3 Setup Drawing

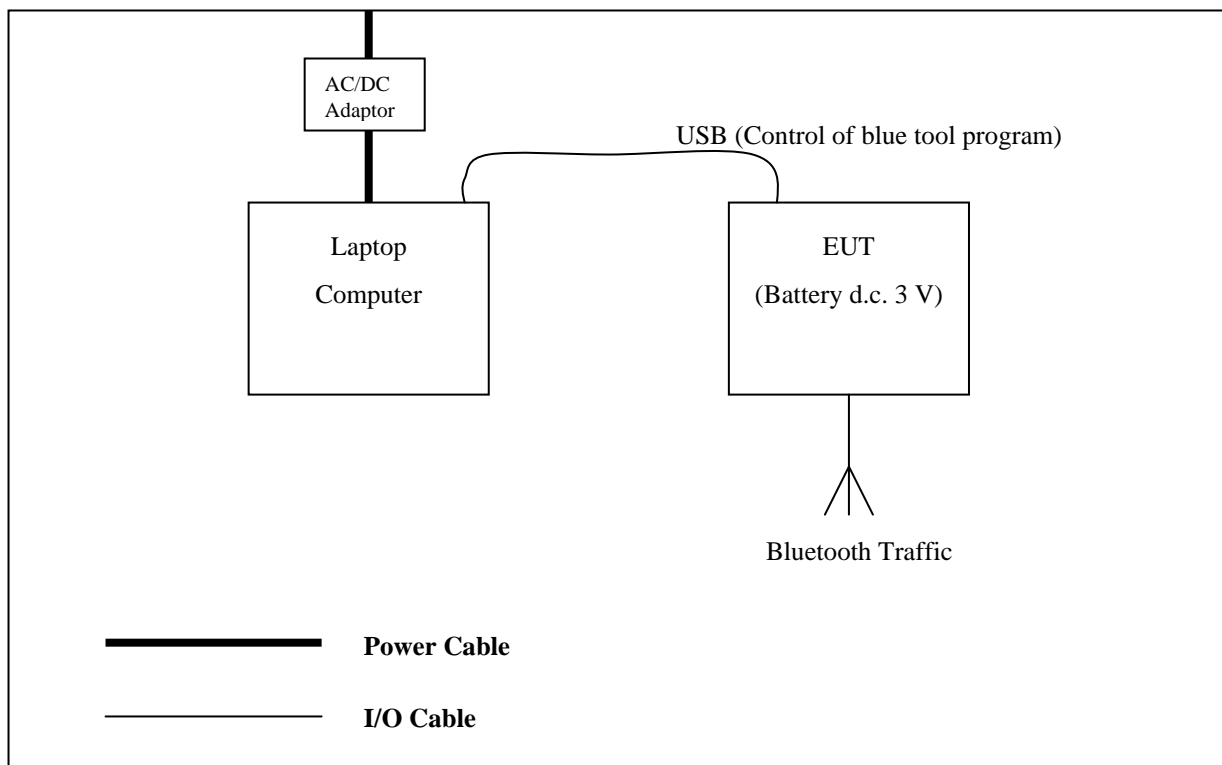

3.4 EUT Information

The EUT is the **Samsung 3D Active Glasses FCC ID: A3LSSG3100GB, IC ID: 649E-SSG3100GB.**

Specifications:

EUT Type	3D Active Glasses
Model Name	SSG-3100GB
Variant Model	SSG-M3150GB
Brand Name	SAMSUNG
RF Frequency	2402 MHz ~ 2480 MHz
Peak Power Output (Conducted)	- 2.76 dBm
Channel Number	79
Modulation	GFSK
Antenna Gain	0.42 dBi (Peak)
Power	3 Vdc (Lithium Battery)
Size	170 mm x 38 mm x 150 mm
Weight	35 g

4. SUMMARY OF TEST RESULTS

The EUT has been tested according to the following specification:

Name of Test	FCC Paragraph No.	IC Paragraph No.	Result	Remark
Conducted Emission	15.207	RSS-GEN 7.2.4	Complies	
Radiated Emission	15.209	RSS-210 A8.5	Complies	
20dB Bandwidth and	15.247(a)(1)(iii)	RSS-210 A8.1	Complies	
Carrier Frequency Separation	15.247(a)(1)	RSS-210 A8.1(2)	Complies	
Transmitter Average Time of Occupancy	15.247(a)(1)(iii)	RSS-210 A8.1(4)	Complies	
Peak Power Output	15.247(b)(1)	RSS-210 A8.4(2)	Complies	
Conducted Spurious Emission	15.247(d)	RSS-210 A8.5	Complies	
Radiated Spurious Emission	15.247(d)	RSS-210 A8.5	Complies	
Number of Hopping channels	15.247(a)(1)(iii)	RSS-210 A8.1(4)	Complies	

5. RECOMMENDATION/CONCLUSION

The data collected shows that the **Samsung 3D Active Glasses FCC ID: A3LSSG3100GB, IC ID: 649E-SSG3100GB** is in compliance with Part 15 Subpart C 15.247 of the FCC Rules.

6. ANTENNA REQUIREMENTS

§15.203 of the FCC Rules part 15 Subpart C

: An intentional radiator shall be designed to ensure that no antenna other than that furnished by the responsible party shall be used with the device. The use of a permanently attached antenna or of an antenna that uses a unique coupling to the intentional radiator shall be considered sufficient to comply with the provisions of this section.

The antenna of the **Samsung 3D Active Glasses FCC ID: A3LSSG3100GB, IC ID: 649E-SSG3100GB** is **Permanently attached** and there are no provisions for connection to an external antenna. It complies with the requirement of §15.203.

7. DESCRIPTION OF TESTS

7.1 Conducted Emissions

The Line conducted emission test facility is located inside a 4 x 7 x 2.5 meter shielded enclosure.

It is manufactured by EM engineering. The shielding effectiveness of the shielded room is in accordance with MIL-STD-285 or NSA 65-6.

A 1 m x 1.5 m wooden table 0.8 m height is placed 0.4 m away from the vertical wall and 1.5 m away from the side of wall of the shielded room Rohde & Schwarz (ESH3-Z5) and Rohde & Schwarz (ESH2-Z5) of the 50 ohm/50 uH Line Impedance Stabilization Network(LISN) are bonded to the shielded room.

The EUT is powered from the Rohde & Schwarz LISN and the support equipment is powered from the R & S LISN (ESH2-Z5). Power to the LISNs are filtered by high-current high insertion loss Power line filters. The purpose of filter is to attenuate ambient signal interference and this filter is also bonded to shielded enclosure. All electrical cables are shielded by tinned copper zipper tubing with inner diameter of 1 / 2 ”.

If DC power device, power will be derived from the source power supply it normally will be powered from and this supply lines will be connected to the LISNs, All interconnecting cables more than 1 meter were shortened by non inductive bundling (serpentine fashion) to a 1 meter length.

Sufficient time for EUT, support equipment, and test equipment was allowed in order for them to warm up to their normal operating condition. The RF output of the LISN was connected to the spectrum analyzer to determine the frequency producing the maximum EME from the EUT.

The spectrum was scanned from 150 kHz to 30 MHz with 200 ms sweep time.

The frequency producing the maximum level was re-examined using the EMI test receiver. (Rohde & Schwarz ESCS30).

The detector functions were set to CISPR quasi-peak mode & average mode.

The bandwidth of receiver was set to 9 kHz. The EUT, support equipment, and interconnecting cables were arranged and manipulated to maximize each EME emission.

Each emission was maximized by; switching power lines; varying the mode of operation or resolution; clock or data exchange speed; scrolling H pattern to the EUT and of support equipment, and powering the monitor from the floor mounted outlet box and computer aux AC outlet, if applicable; which ever determined the worst case emission.

Each EME reported was calibrated using the R & S signal generator.

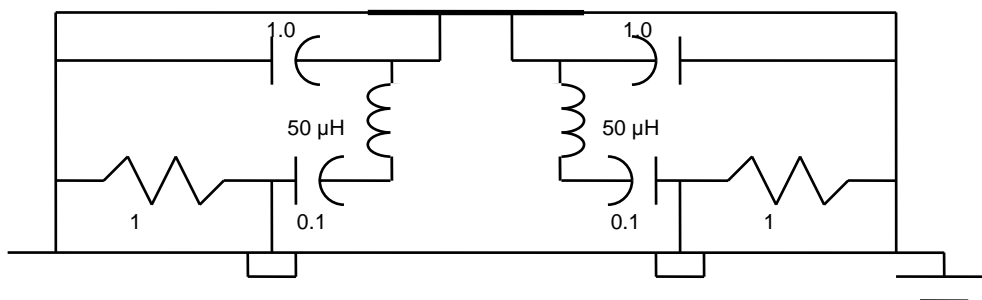

Fig. 2. LISN Schematic Diagram

7.2 Radiated Emissions

Preliminary measurements were made indoors at 3 meter using broad band antennas, broadband amplifier, and spectrum analyzer to determine the frequency producing the maximum EME. Appropriate precaution was taken to ensure that all EME from the EUT were maximized and investigated. The Technology configuration, clock speed, mode of operation or video resolution, turntable azimuth with respect to the antenna was note for each frequency found. The spectrum was scanned from 9 kHz to 30 MHz using Loop Antenne(EMCO, 6502) and 30 to 1000 MHz using Bi-conical log Antenna(ARA, LPB-2520/A). Above 1 GHz, Horn antenna (Scwarzbeck BBHA 9120D: up to 18 GHz, Q-par Angus QSH20S20 : 18 to 26.5 GHz, QSH22K20: up to 40 GHz) was used. Final Measurements were made outdoors at 3 or 10 m test range using Loop Antenne(EMCO, 6502) and Logbicon Super Antenna (Schwarzbeck, VULB9168) or Horn antenna.(Scwarzbeck BBHA 9120D: up to 18 GHz, Q-par Angus QSH20S20 : 18 to 26.5 GHz, QSH22K20: up to 40 GHz).

The test equipment was placed on a wooden table. Sufficient time for the EUT, support equipment, and test equipment was allowed in order for them to warm up to their normal operating condition.

Each frequency found during pre-scan measurements was reexamined and investigated using EMI test receiver (ESCS30) & (FSP40). The detector function was set to CISPR peak mode or quasi-peak mode or average mode and the band-width of the receiver was set to 120 kHz or 1 MHz depending on the frequency or type of signal. The half wave dipole antenna was tuned to the frequency found during preliminary radiated measurements. The EUT support equipment and interconnecting cables were re configured to the setup producing the maximum emission for the frequency and were placed on top of a 0.8 m high non- metallic 1.0 x 1.5 meter table. The EUT, support equipment and interconnecting cables were re-arranged and manipulated to maximize each EME emission. The turn table containing the Technology was rotated; the antenna height was varied 1 to 4 meter and stopped at the azimuth or height producing the maximum emission Each emission was maximized by : switching power lines; varying the mode of operation or resolution; clock or data exchange speed; scrolling H pattern to the EUT and of support equipment, and powering the monitor from the floor mounted outlet box and computer aux AC outlet, if applicable; which ever determined the worst case emission.

Each EME reported was calibrated using the R/S signal generator.

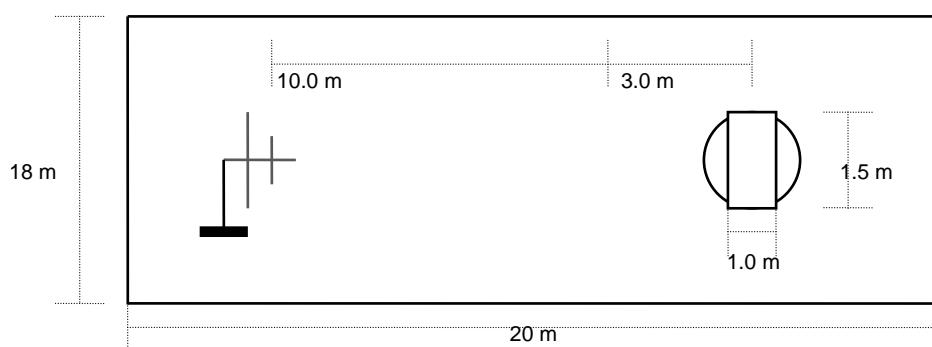
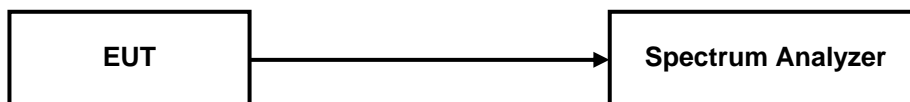

Fig. 3. Dimensions of Outdoor Test Site

7.3 20 dB Bandwidth and Carrier Frequency Separation

Test Setup



Test Procedure

The transmitter is set to the Low , Middle, High channels is connected to the spectrum analyzer. The RBW of spectrum analyzer is set to 30 kHz and VBW is set to the 100 kHz. The sweep time is coupled.

The spectrum analyzer is set for peak detected and Max hold scan mode.

When Carrier Frequency separation is tested, Frequency hopping is set.

7.4 Transmitter Average Time of Occupancy

Test Setup

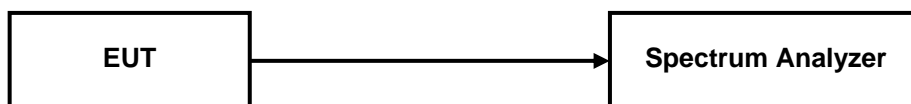

Test Procedure

The transmitter output is connected to a spectrum analyzer. The span is set to zero, centered on a single, selected hopping channel.

The width of a single pulse is measured in a fast scan. The number of pulses is measured in 3.16 second scan, to enable resolution of each occurrence.

The average time of occupancy in the specified 31.6 second period (79 channel x 0.4 s) is equal to 10 x number of pulses in 3.16 second x pulse width.

7.5 Number of Hopping Channels

Test Setup

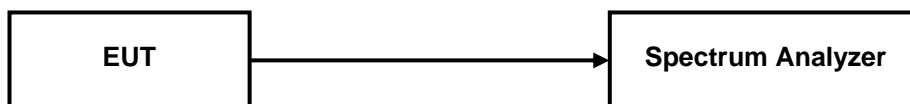

Test Procedure

The transmitter output is connected to a spectrum analyzer. The span is set to cover the entire authorized band, In either a single sweep or in multiple continuous sweeps. The RBW is set to 1 % of the span.

The spectrum analyzer is set to Max Hold.

7.6 Maximum Peak Output Power

Test Setup

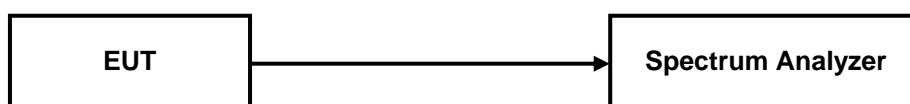

Test Procedure

The transmitter is set to the Low , Middle, High channels is connected to the spectrum analyzer. The RBW of spectrum analyzer is set to 3 MHz and VBW is set to the 3 MHz. The sweep time is coupled.

7.7 Conducted Spurious Emission

Test Setup

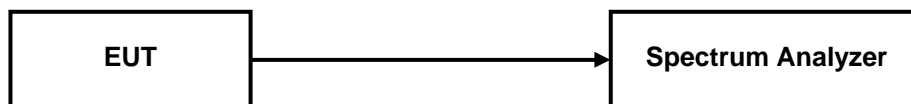

Test Procedure

The transmitter is connected to the spectrum analyzer.

The RBW of spectrum analyzer is set to 100 kHz and VBW is set to the 100 kHz.

Measurements are made over the 30 MHz to 25 GHz range with the transmitter set to the Lowest, Middle and highest channels.

8. TEST DATA

8.1 Radiated Emissions

FCC §15.209, IC RSS-210 A8.5

Frequency (MHz)	Reading (dB μ V/m)	Pol* (H/V)	Antenna Height (cm)	Turntable Angles (°)	AF+CL+Amp (dB)**	Result (dB μ V/m)	Limit (dB μ V/m)	Margin (dB)
120.08	52.1	H	100	301	-19.9	32.2	43.5	11.3
132.10	49.0	H	120	277	-17.1	31.9	43.5	11.6
144.10	47.7	H	201	331	-17.1	30.6	43.5	12.9
168.02	45.3	H	178	97	-15.5	29.8	43.5	13.7
336.20	50.0	H	100	104	-13.6	36.4	46.0	9.6
432.25	46.1	H	250	58	-11.1	35.0	46.0	11.0

Radiated Measurements at 3 meters

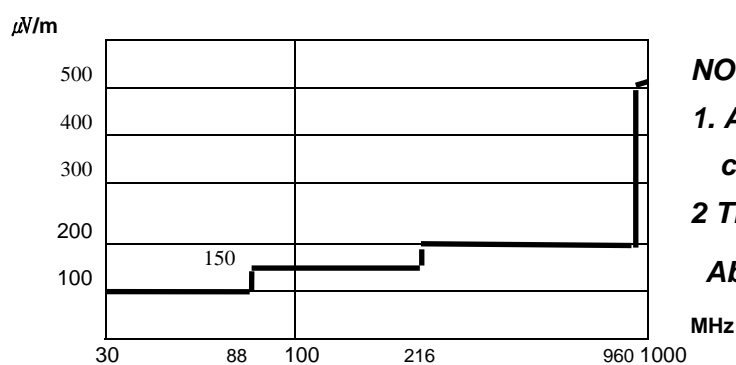

Fig. 4. Limits at 3 meters

NOTES:

1. All modes were measured and the worst-case emission was reported.
 - 2 The radiated limits are shown on Figure 4.
- Above 1 GHz the limit is 500 μ V/m.

MHz

NOTES:

1. *Pol. H = Horizontal V = Vertical
2. **AF + CL + Amp. = Antenna Factor + Cable Loss + Amplifier.
3. Measurements using CISPR quasi-peak mode below 1 GHz.
4. The radiated emissions testing were made by rotating through three orthogonal axes. The worst date was recorded.
5. The limit is on the FCC Part section 15.209(a).

TEST DATA

8.2 20 dB Modulated Bandwidth

FCC §15.247(a)(1)(iii), RSS-210 A8.1

Test Mode : Set to Lowest channel, Middle channel and Highest channel

Result:

Modulation Mode	Frequency(MHz)	Result(KHz)	Limit(KHz)
GFSK	2402	1044	Non specified
GFSK	2441	1050	Non specified
GFSK	2480	1050	Non specified

PLOTS OF EMISSIONS

20 dB Bandwidth, Lowest Channel (2402 MHz, GFSK Mode)

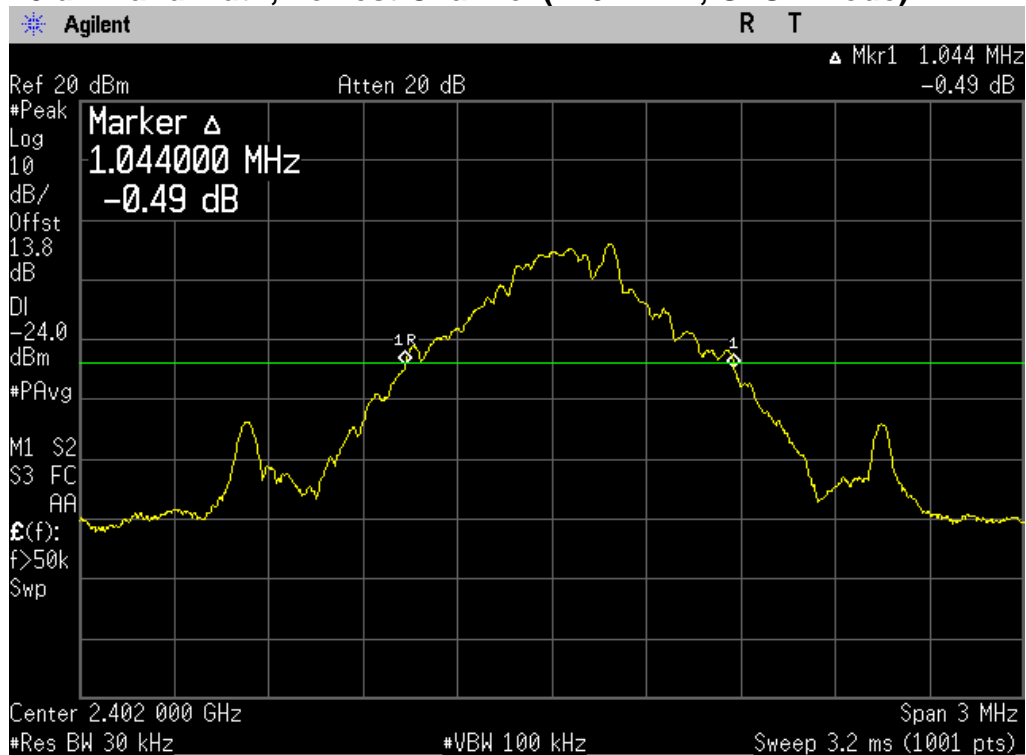

20 dB Bandwidth, Middle Channel (2441 MHz, GFSK Mode)

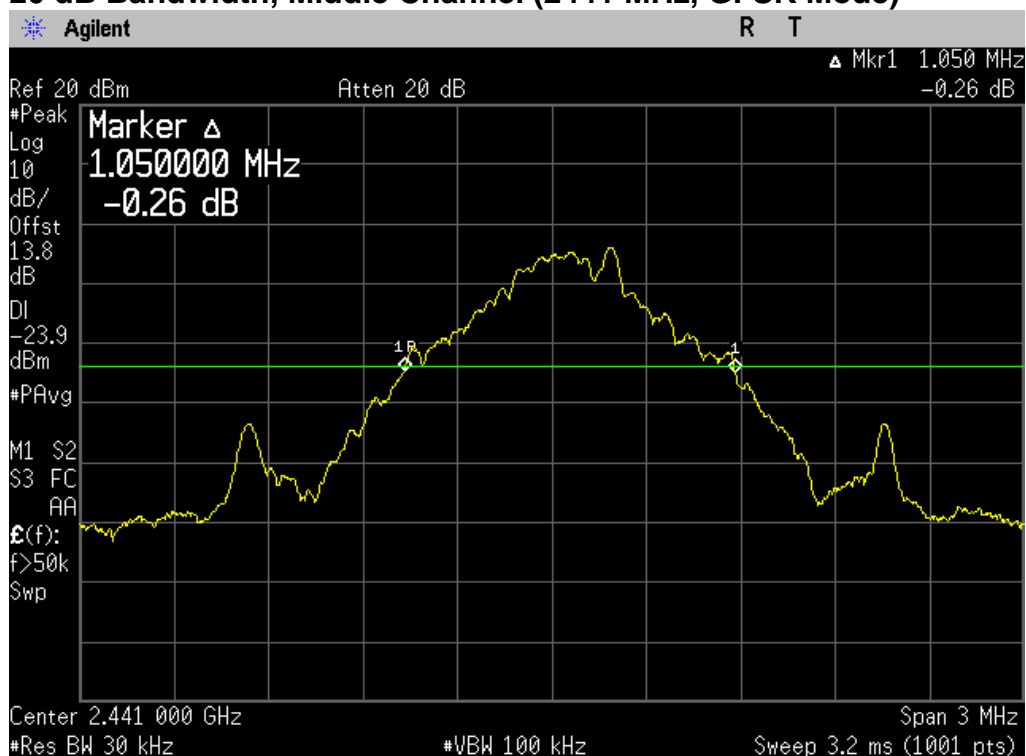

PLOTS OF EMISSIONS

20 dB Bandwidth, Highest Channel (2480 MHz, GFSK Mode)

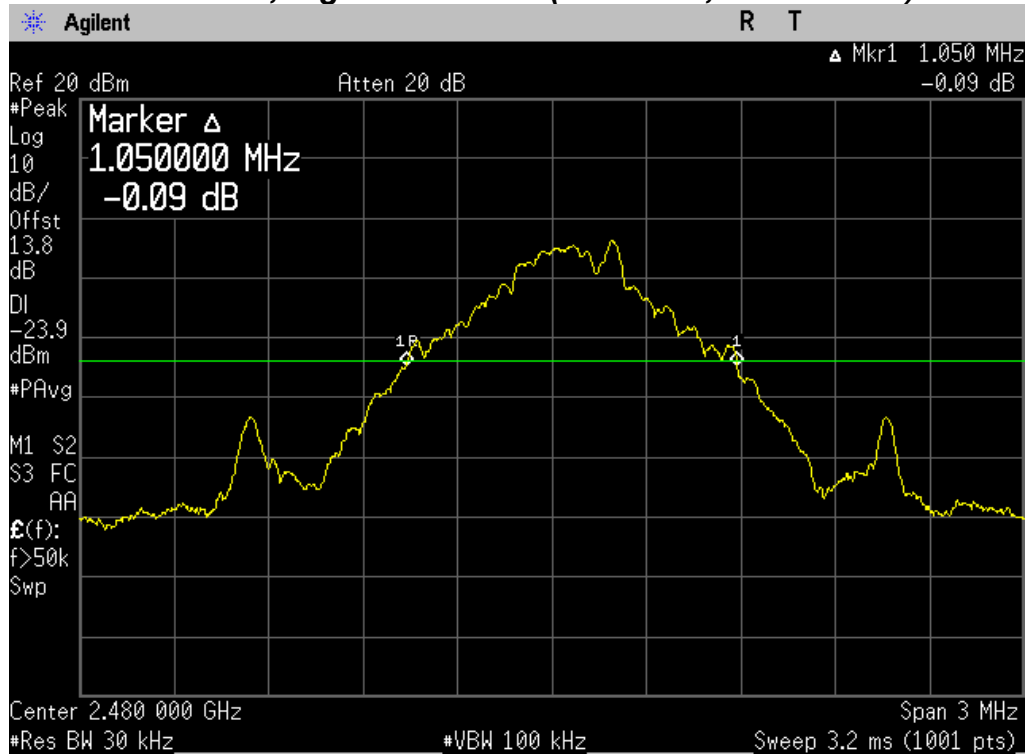

TEST DATA

8.3 Carrier Frequency Separation

FCC §15.247(a)(1), RSS-210 A8.1(2)

Test Mode : Set to Hopping mode

Result:

Modulation Mode	Carrier Frequency Separation (kHz)	Limit (2/3 of 20dB Bandwidth) (kHz)	Margin (kHz)
GFSK	1000.0	700	300

PLOTS OF EMISSIONS

Carrier Frequency Separation (GFSK Mode)

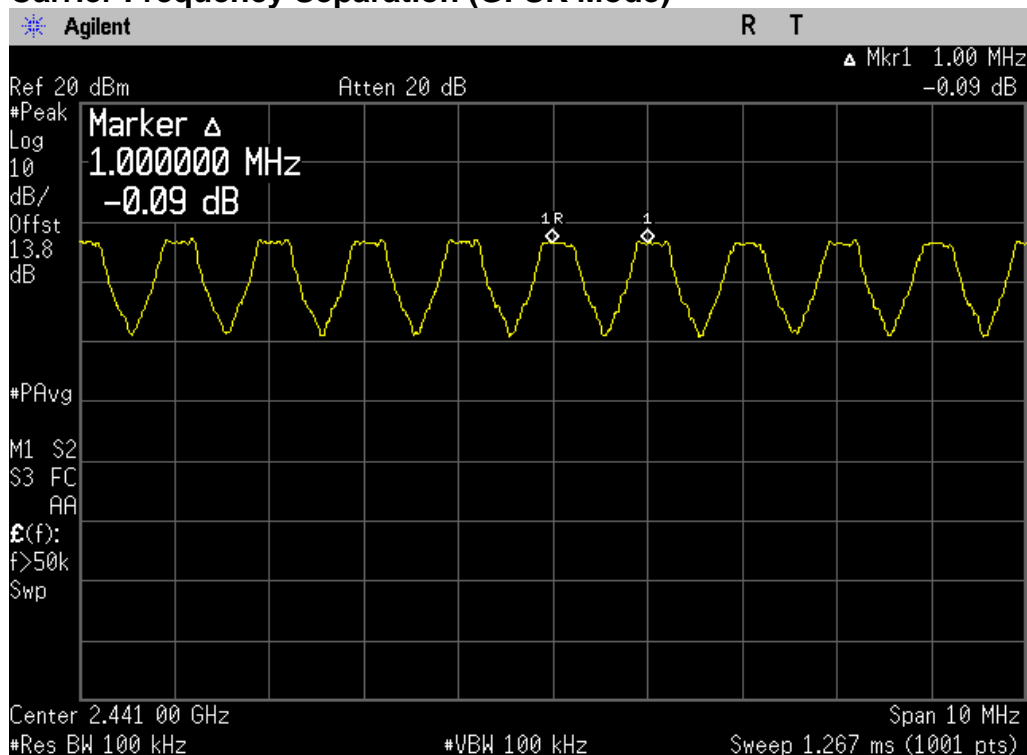

TEST DATA

8.4 Transmitter Average Time of Occupancy

FCC §15.247(a)(1)(iii), RSS-210 A8.1(4)

Test Mode : Set to Hopping mode

Result:

Modulation Mode	Pulse width ()	Number of 3.16 second	¹⁾ Average time of Occupancy(s)	Margin (s)
GFSK	2890	11	0.3179	0.0821

Notes:

¹⁾ Average time of Occupancy = pulse width x Number of 3.16 sec x 10

PLOT OF TEST DATA

One pulse Width

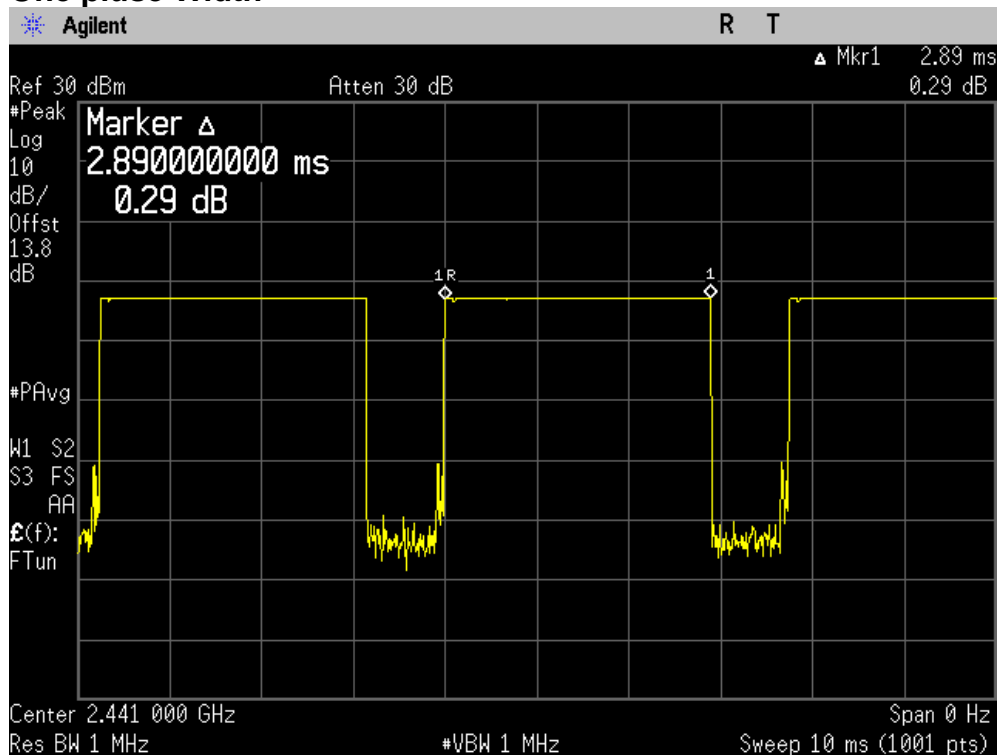

Number of pulses in 3.16 second period

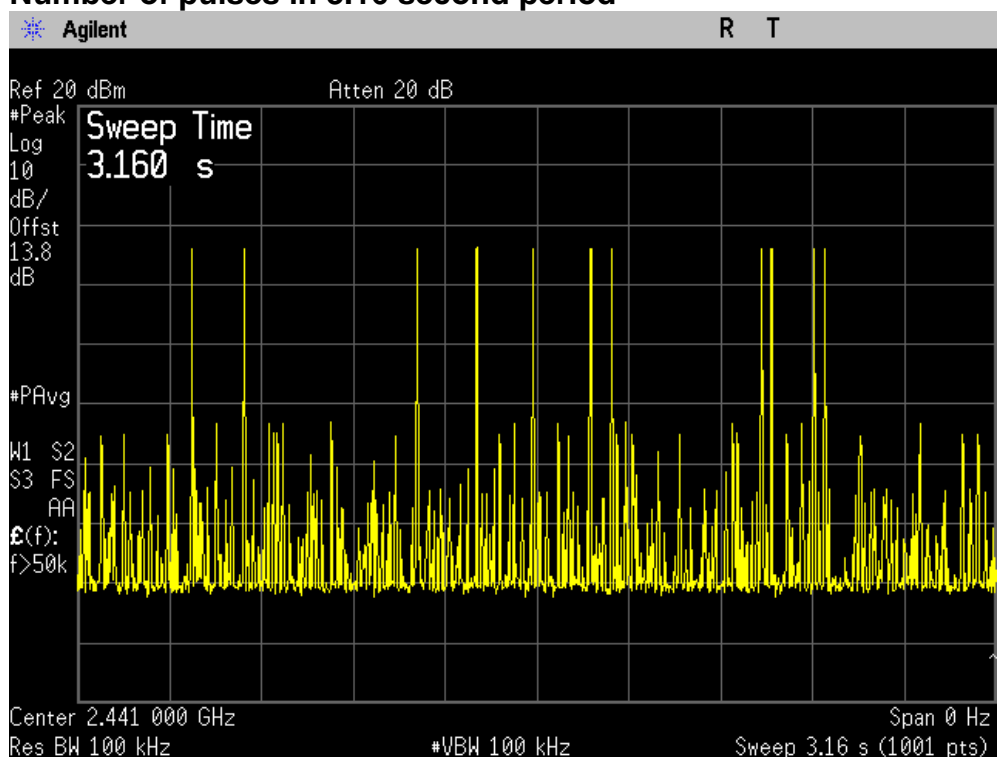

TEST DATA

8.5 Number of Hopping Channels

FCC §15.247(a)(1)(iii), RSS-210 A8.1(4)

Test Mode : Set to Hopping mode

Result:

Total Hopping Channels = 40 + 39 = 79

The EUT meets the specifications of Section 15.247(a)(1)(iii) for Number of Hopping Channels.

PLOT OF TEST DATA

Top half of Authorized band

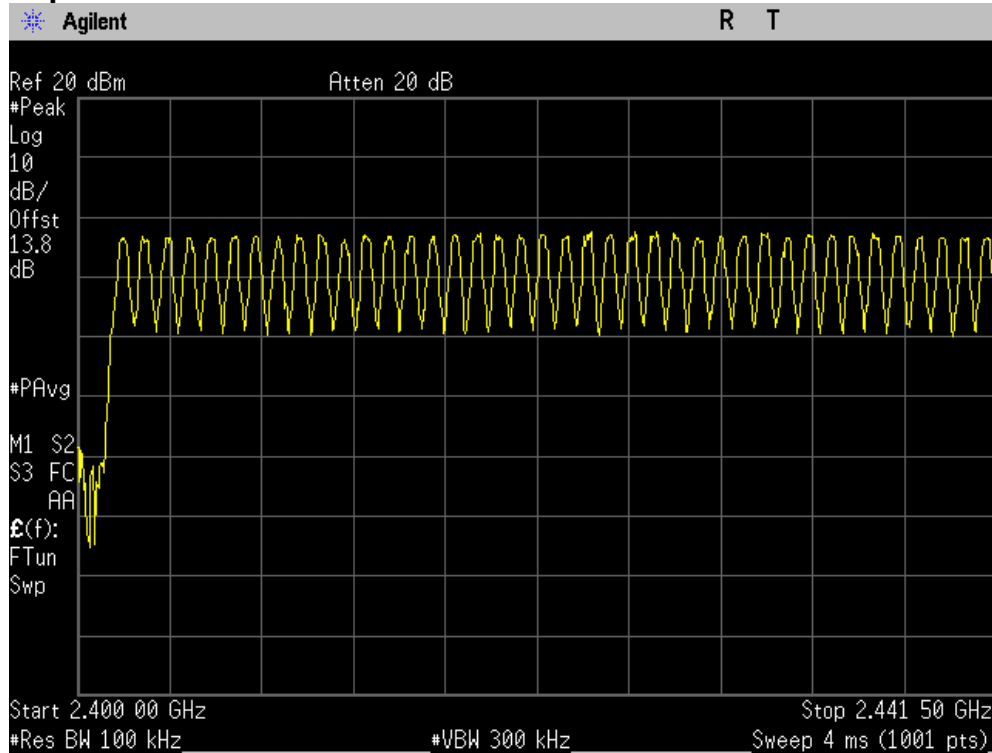

Bottom half of Authorized band

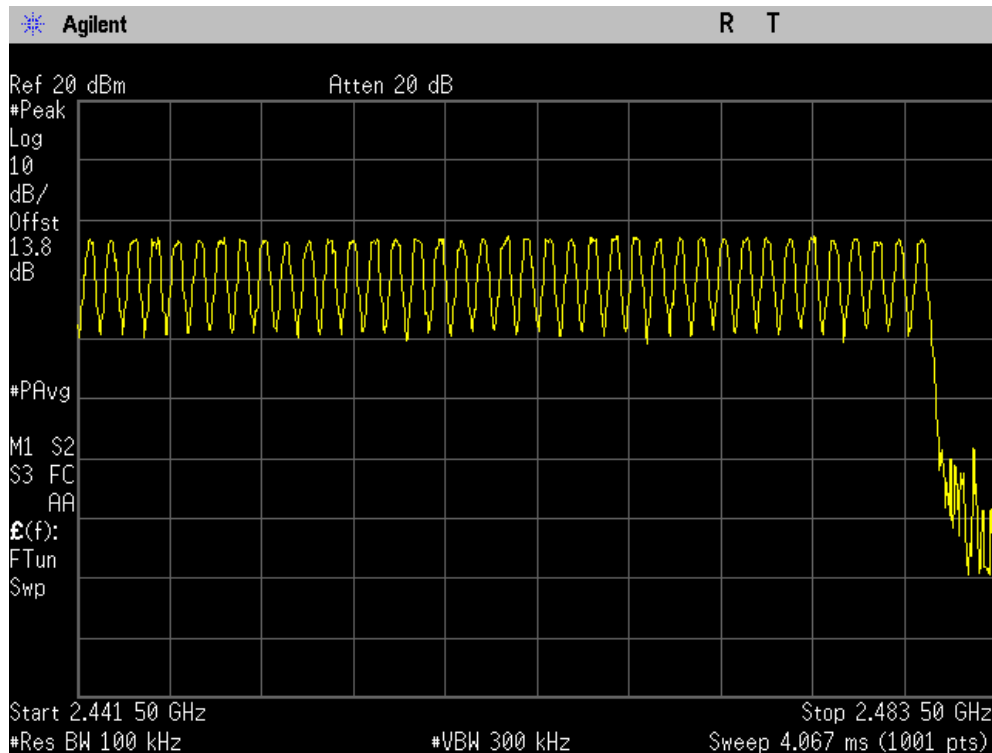

TEST DATA

8.6 Peak Power Output

FCC §15.247(b)(1), RSS-210 A8.4(2)

Test Mode : Set to Lowest channel, Middle channel and Highest channel

Result:

Modulation Mode	Frequency (MHz)	Peak Power (dBm)	Limit (dBm)
GFSK	2402	-2.92	30
GFSK	2441	-2.83	30
GFSK	2480	-2.76	30

PLOT OF TEST DATA

Output Power, Lowest Channel (2402 MHz, GFSK Mode)

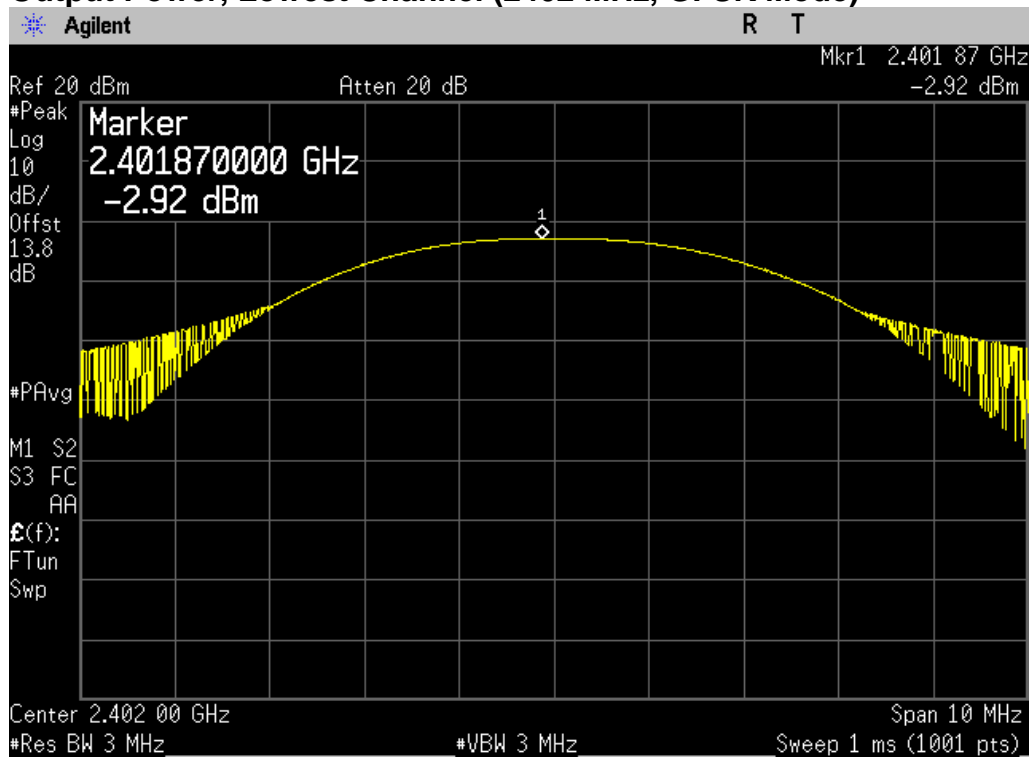

Output Power, Middle Channel (2441 MHz, GFSK Mode)

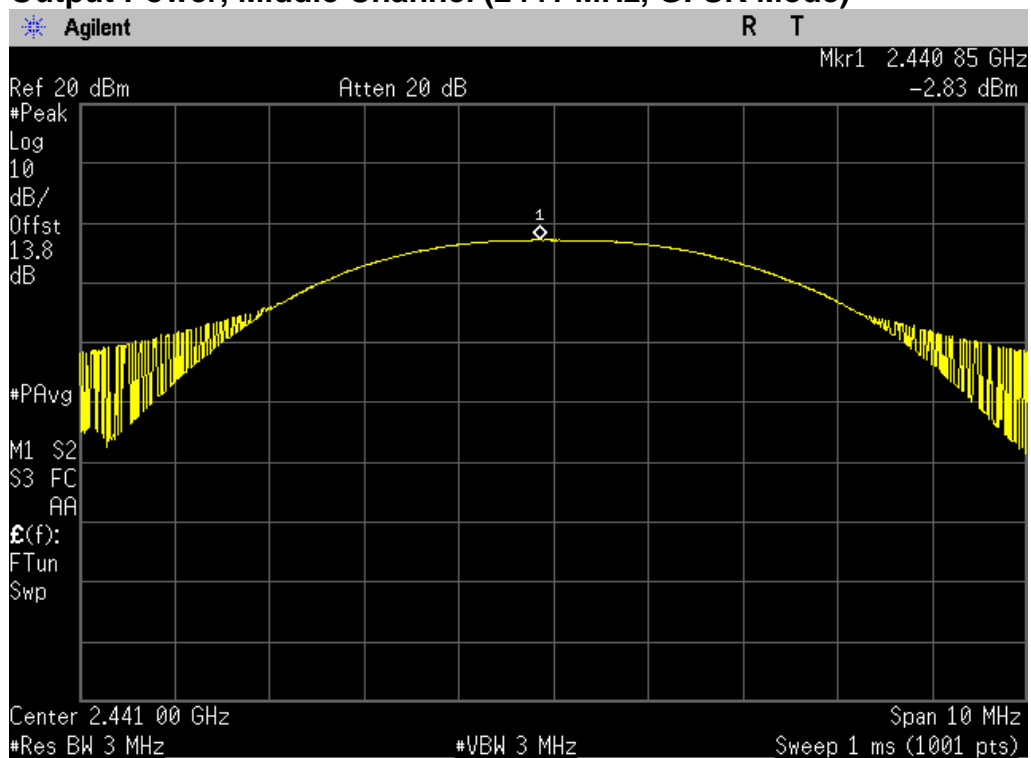

PLOT OF TEST DATA

Output Power, Highest Channel (2480 MHz, GFSK Mode)

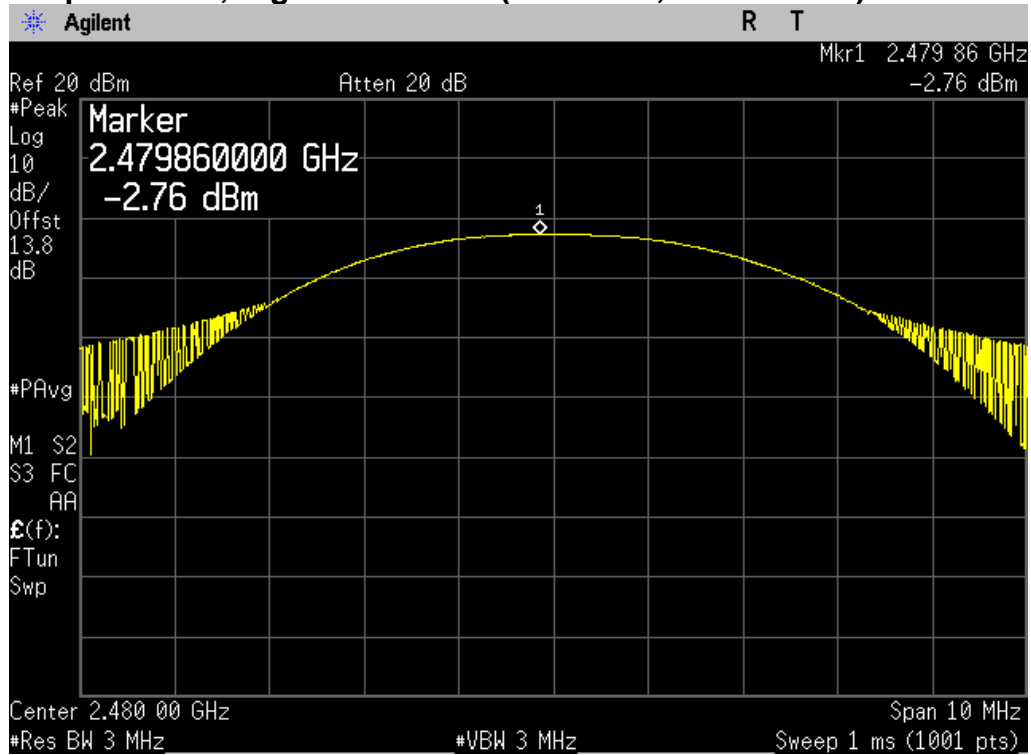

TEST DATA

8.7 Conducted Spurious Emission

FCC §15.247(d), RSS-210 A8.5

Test Mode : Set to Lowest channel, Middle channel and Highest channel

Result:

Modulation Mode	Frequency(MHz)	Result	Limit(dBc)
GFSK	2402	More than 30 dBc	20
GFSK	2441	More than 30 dBc	20
GFSK	2480	More than 30 dBc	20

PLOT OF TEST DATA

Conducted Spurious Emissions, 30 MHz ~ 10 GHz(2402 MHz, GFSK Mode)

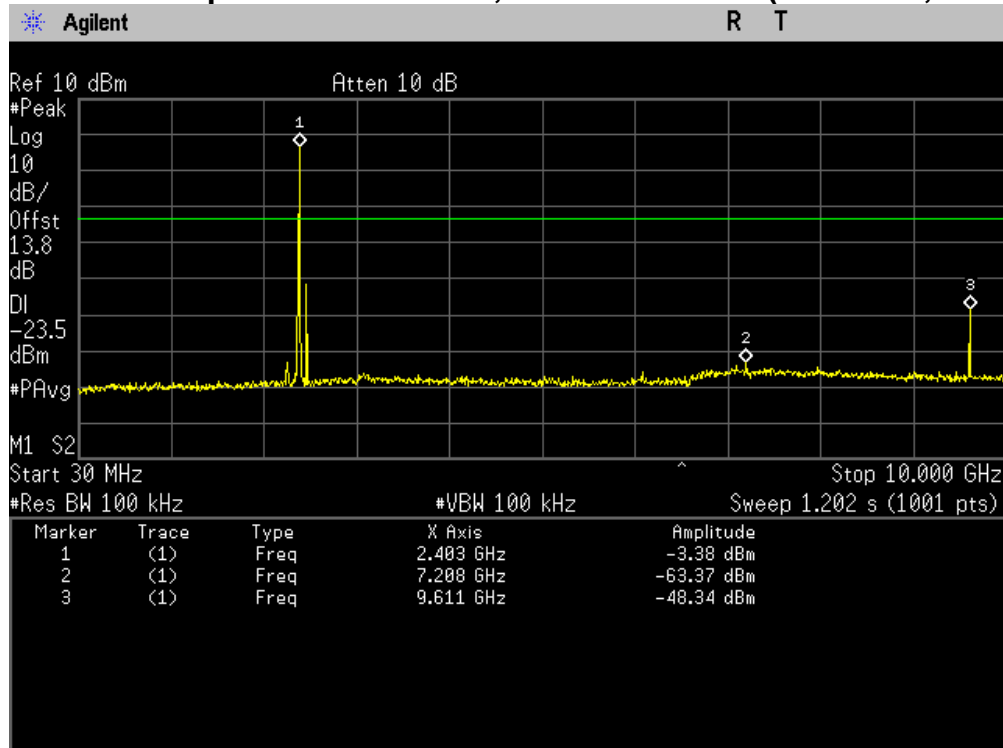

Conducted Spurious Emissions, 10 GHz ~ 26.5 GHz(2402 MHz, GFSK Mode)

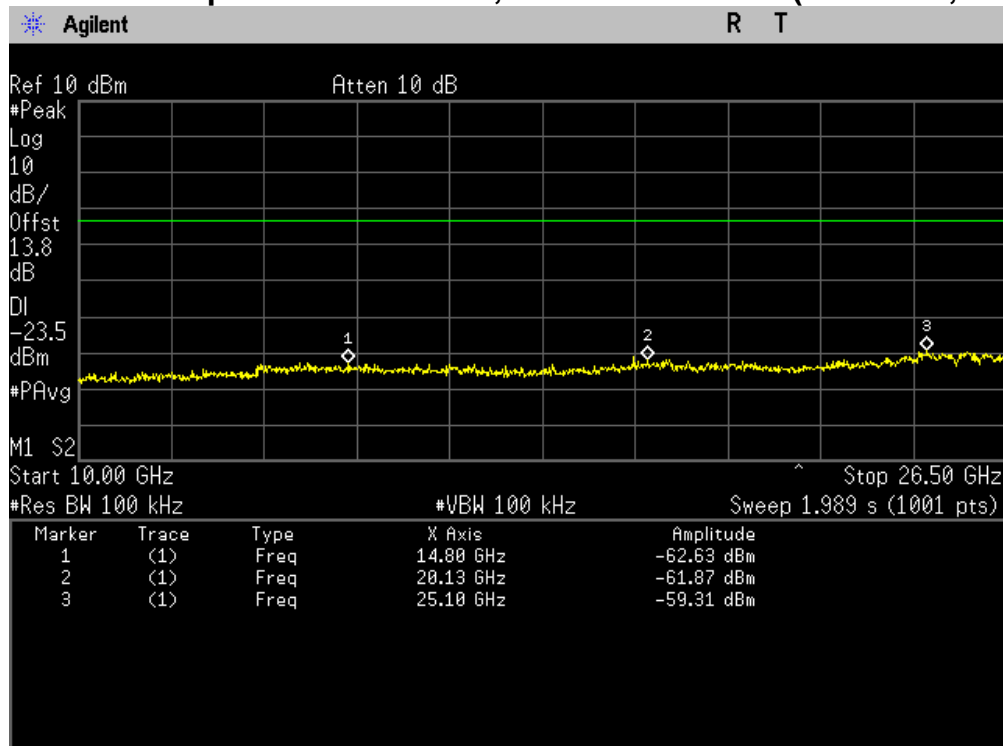

PLOT OF TEST DATA

Conducted Spurious Emissions, 30 MHz ~ 10 GHz(2441 MHz, GFSK Mode)

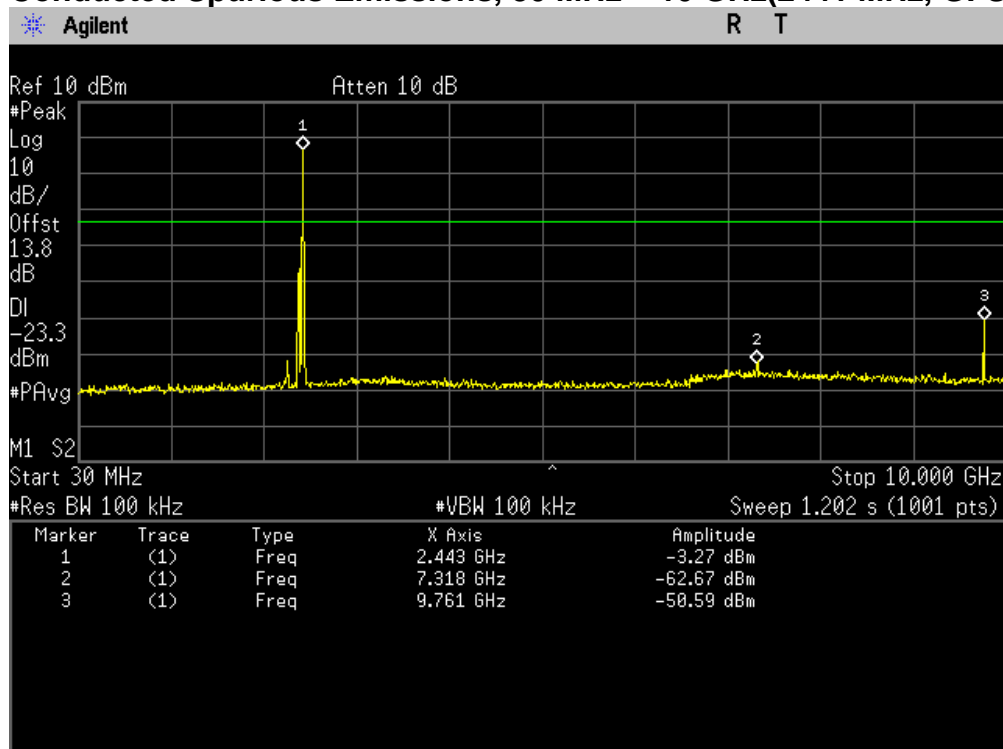

Conducted Spurious Emissions, 10 GHz ~ 26.5GHz(2441 MHz, GFSK Mode)

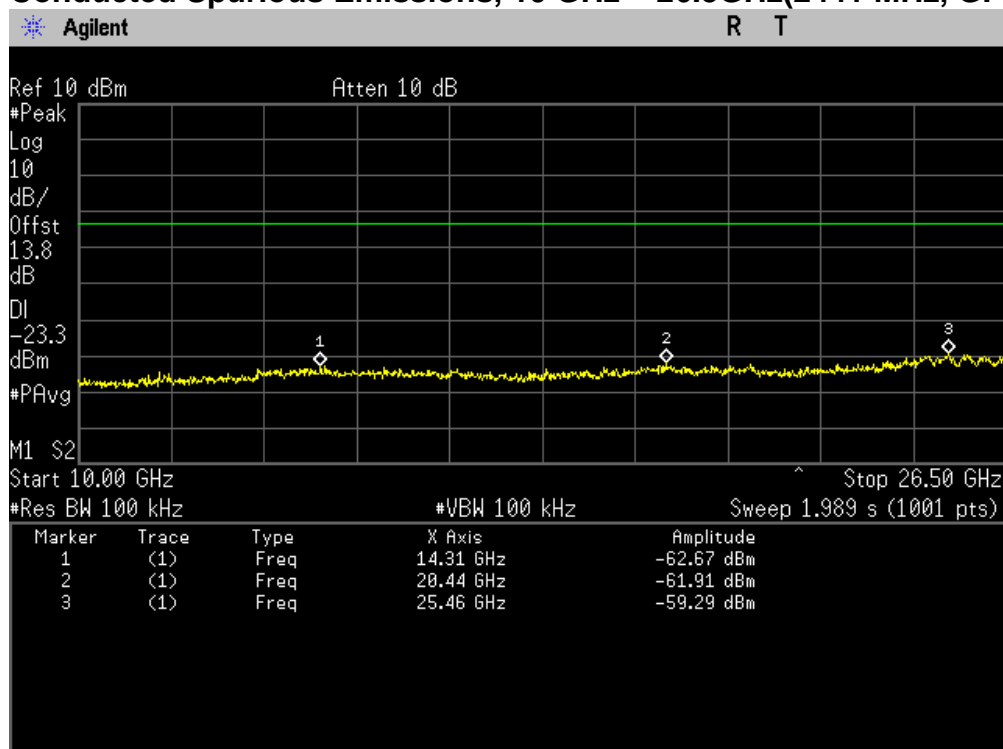

PLOT OF TEST DATA

Conducted Spurious Emissions, 30 MHz ~ 10 GHz(2480 MHz, GPSK Mode)

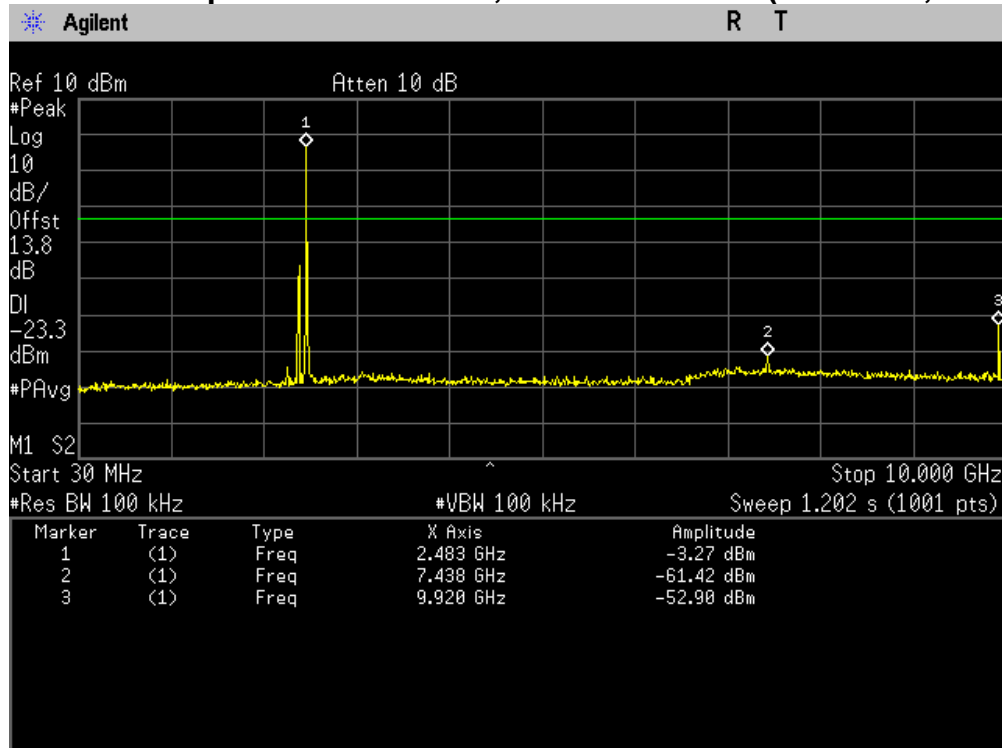

Conducted Spurious Emissions, 10 GHz ~ 26.5 GHz(2480 MHz, GPSK Mode)

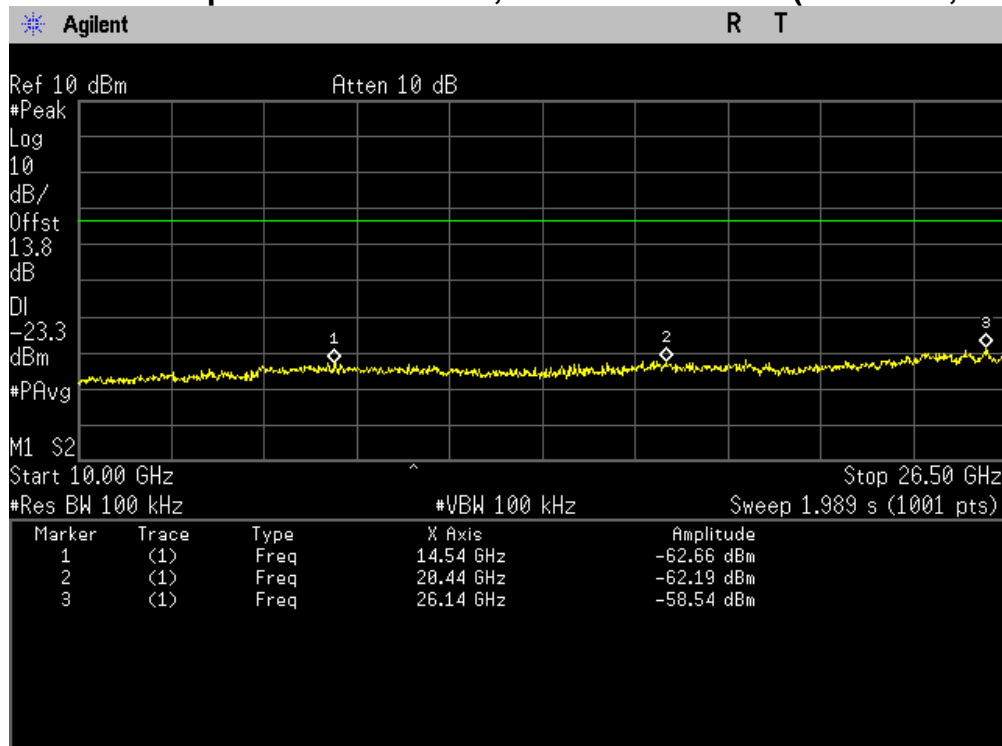

PLOT OF TEST DATA

Band Edge , Lowest Channel(2402 MHz, GFSK Mode)

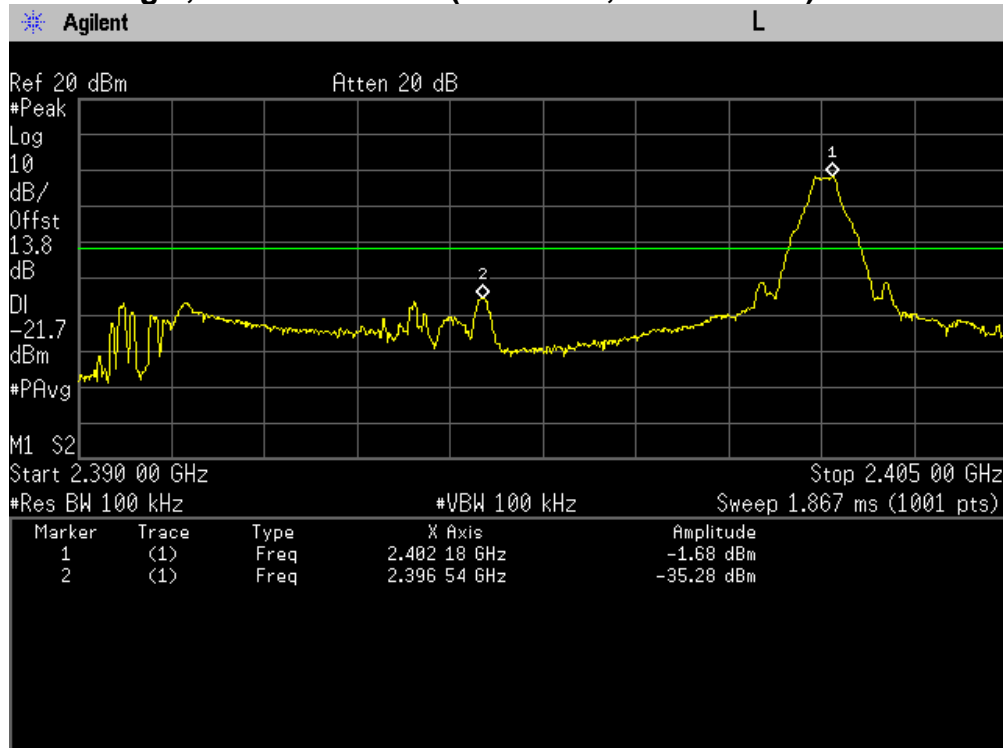

Band Edge , Highest Channel(2480 MHz, GFSK Mode)

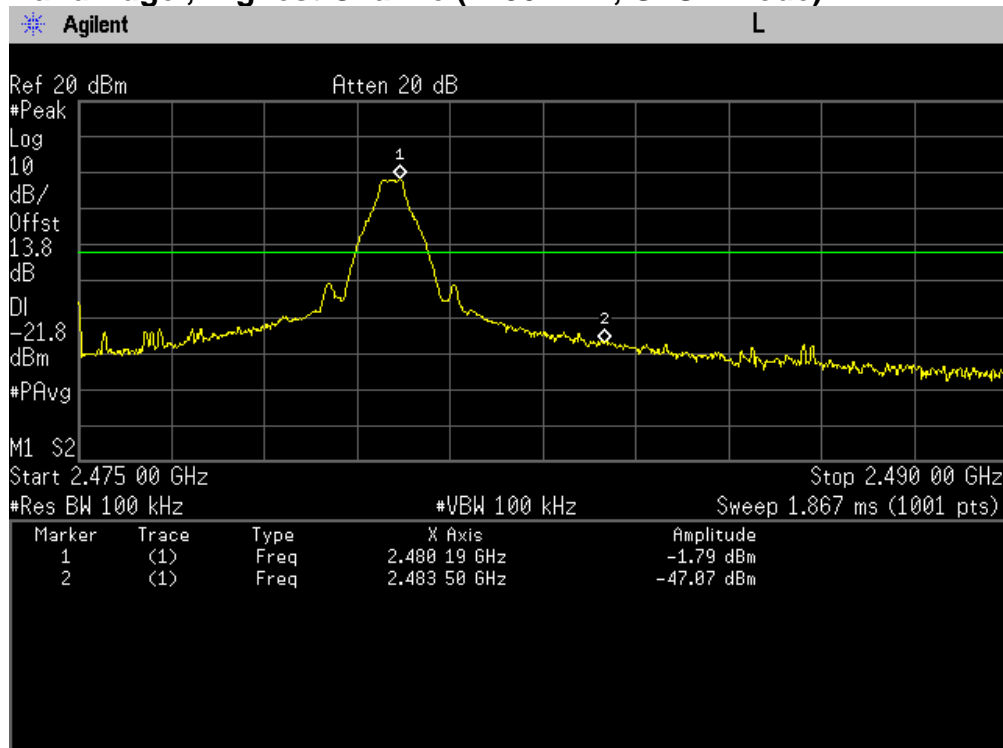

TEST DATA

8.8 Radiated Spurious Emission

FCC §15.247(d), RSS-210 A8.5

Test Mode : Set to Lowest channel, Middle channel and Highest channel

Result:

Lowest Channel

Frequency (MHz)	Reading (dB μV)	Pol* (H/V)	mode	AF+CL+Amp (dB)**	Result (dB $\mu V/m$)	Limit (dB $\mu V/m$)	Margin (dB)
1332	54.50	V	peak	-5.00	49.50	74.0	24.50
1329	43.80	V	average	-5.00	38.80	54.0	15.20
1536	50.00	V	peak	-4.50	45.50	74.0	28.50
1536	45.80	V	average	-4.50	41.30	54.0	12.70
4803	40.90	V	peak	8.20	49.10	74.0	24.90
4803	30.50	H	average	8.20	38.70	54.0	15.30

Middle Channel

Frequency (MHz)	Reading (dB μV)	Pol* (H/V)	mode	AF+CL+Amp (dB)**	Result (dB $\mu V/m$)	Limit (dB $\mu V/m$)	Margin (dB)
1328	54.40	V	peak	-5.00	49.40	74.0	24.60
1329	43.80	V	average	-5.00	38.80	54.0	15.20
1536	50.00	V	peak	-4.50	45.50	74.0	28.50
1536	45.90	V	average	-4.50	41.40	54.0	12.60
4882	41.40	H	peak	8.40	49.80	74.0	24.20
4882	33.50	H	average	8.40	41.90	54.0	12.10

TEST DATA

Highest Channel

Frequency (MHz)	Reading (dB $\mu\bar{V}$)	Pol* (H/V)	mode	AF+CL+Amp (dB)**	Result (dB $\mu\bar{V}/m$)	Limit (dB $\mu\bar{V}/m$)	Margin (dB)
1327	54.40	V	peak	-5.00	49.40	74.0	24.60
1329	43.60	V	average	-5.00	38.60	54.0	15.40
1536	50.00	V	peak	-4.50	45.50	74.0	28.50
1536	45.90	V	average	-4.50	41.40	54.0	12.60
4960	42.50	H	peak	8.60	51.10	74.0	22.90
4960	35.50	H	average	8.60	44.10	54.0	9.90

1. *Pol. H = Horizontal V = Vertical
2. **AF + CL + Amp. = Antenna Factor + Cable Loss + Amplifier.
3. Other spurious are under 20 dB below Fundamental.
4. The radiated emissions testing were made by rotating through three orthogonal axes.
The worst date was recorded.
5. For measurements the resolution bandwidth is set to 1 MHz, and then the video bandwidth is set to 1 MHz for peak measurements and 10 Hz for average measurements.
6. The spectrum is measured from 9 kHz to 10th harmonic and the worst-case emissions are reported. No significant emissions were found beyond the fifth harmonic for this device.

PLOT OF TEST DATA

Restricted Band Spurious Emissions, Lowest channel(GFSK, Peak)

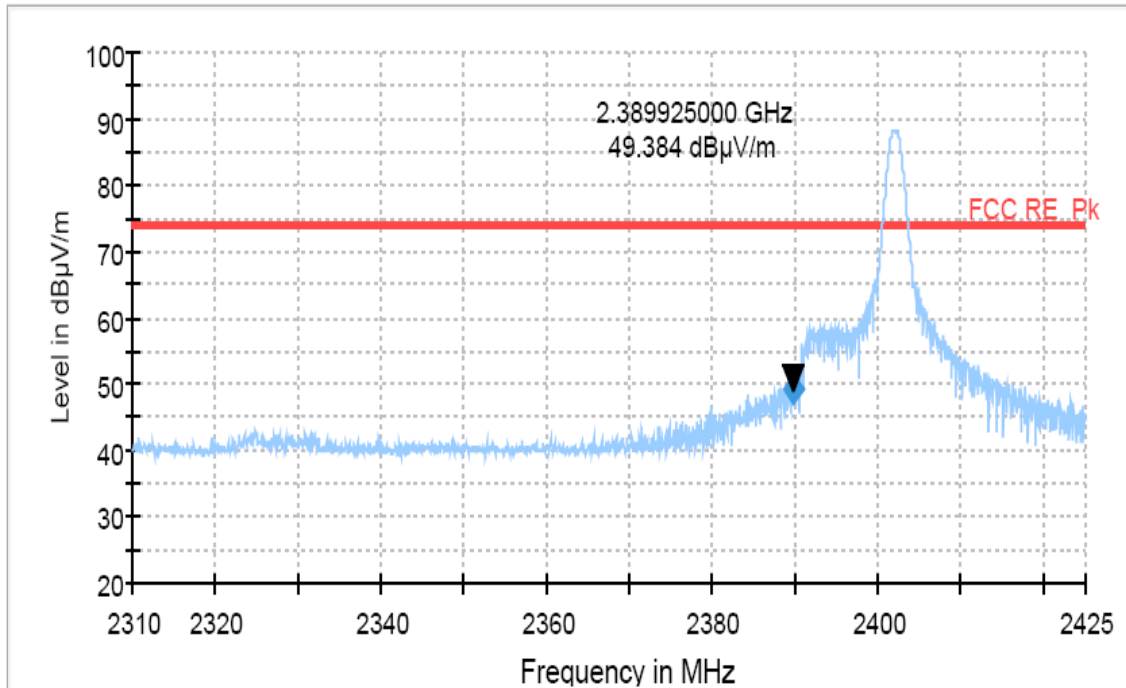

Restricted Band Spurious Emissions, Lowest channel(GFSK, Average)

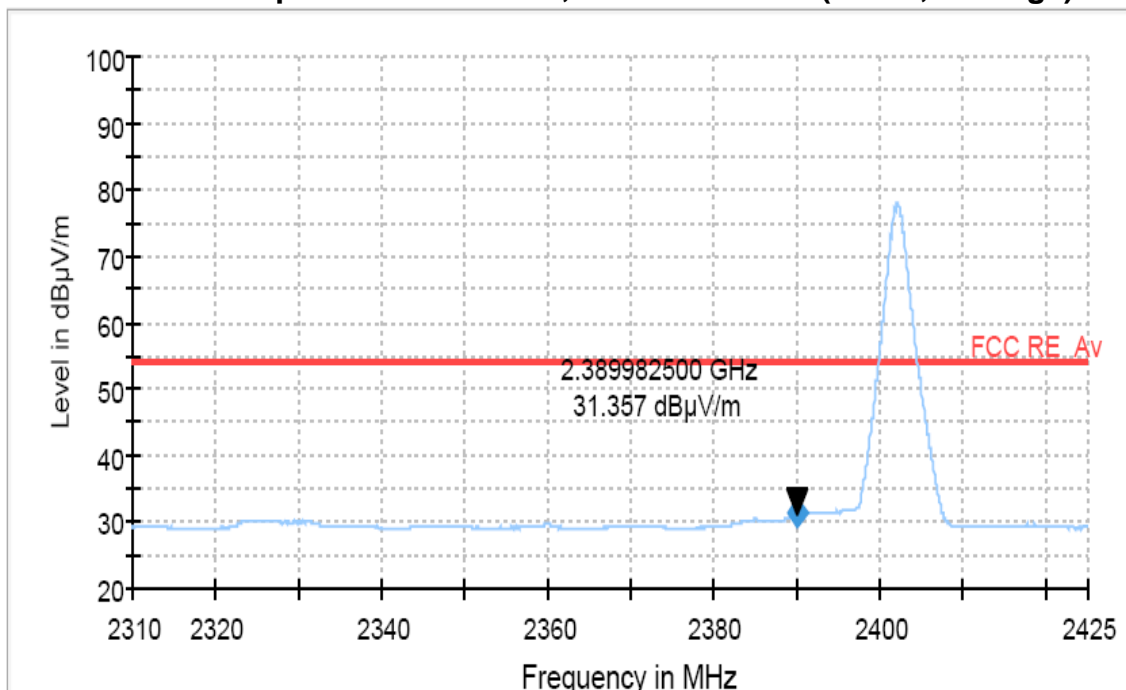

PLOT OF TEST DATA

Restricted Band Spurious Emissions, Highest channel(GFSK, Peak)

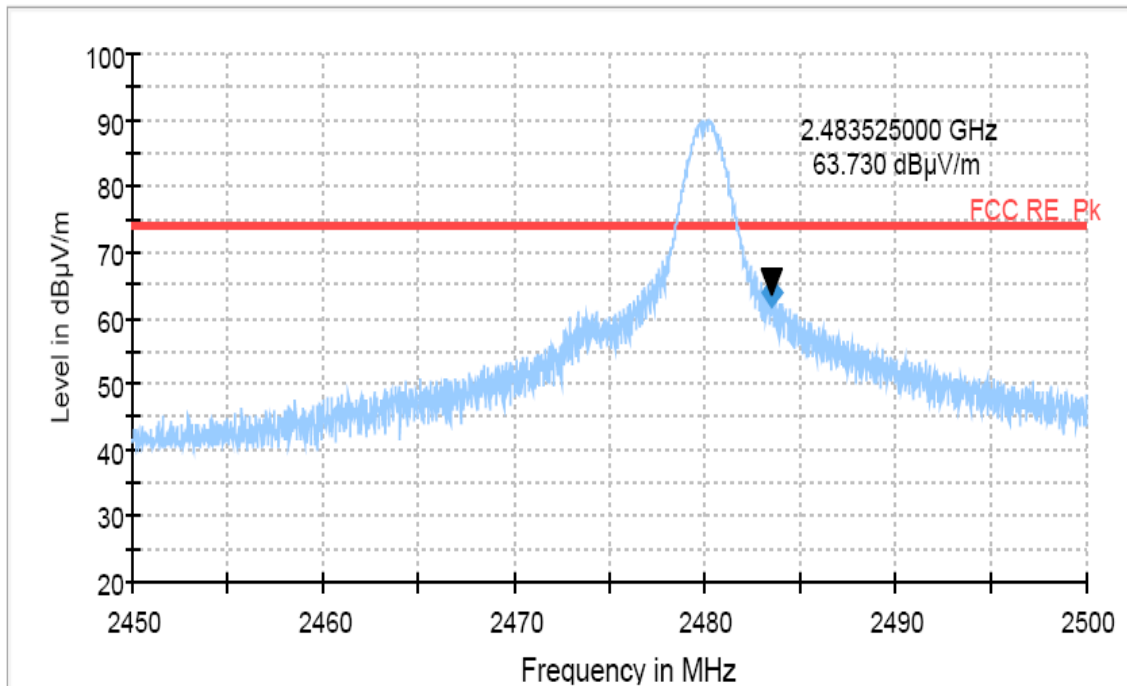

Restricted Band Spurious Emissions, Highest channel(GFSK, Average)

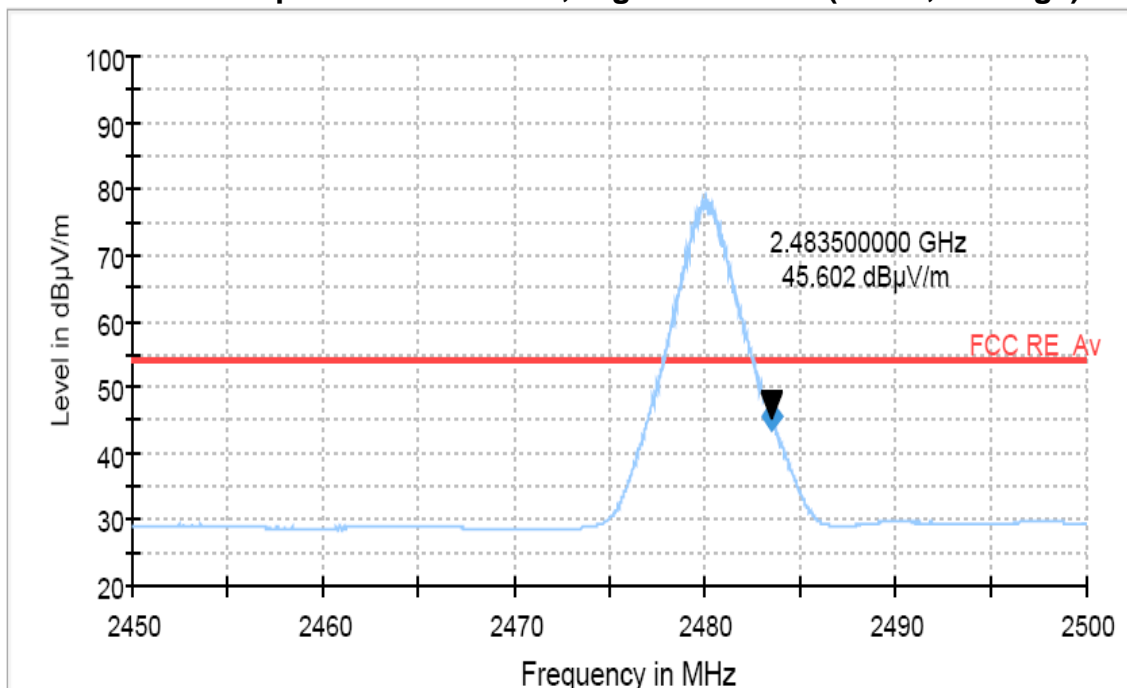

Note: For the radiated emission field strength measurements at the band edges, the resolution bandwidth and video bandwidth were set to 1 MHz. Peak detector was used.

TEST DATA

8.9 Receiver Spurious Emissions

RSS-GEN 7.2.5

Frequency (MHz)	Reading (dB μ V/m)	Pol* (H/V)	Antenna Heights (cm)	Turntable Angles (°)	AF+CL+Amp (dB)**	Result (dB μ V/m)	Limit (dB μ V/m)	Margin (dB)
120.08	51.6	H	100	297	-19.9	31.7	43.5	11.8
132.10	48.7	H	118	277	-17.1	31.6	43.5	11.9
144.10	48.1	H	198	335	-17.1	31.0	43.5	12.5
168.02	44.9	H	175	103	-15.5	29.4	43.5	14.1
336.20	50.2	H	100	102	-13.6	36.6	46.0	9.4
432.25	45.8	H	246	61	-11.1	34.7	46.0	11.3

Radiated Measurements at 3meters

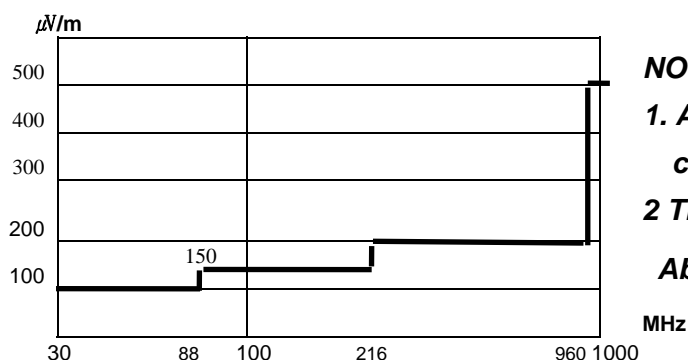

Fig. 5. Limits at 3 meters

NOTES:

1. All modes were measured and the worst-case emission was reported.
 - 2 The radiated limits are shown on Figure 5.
- Above 1 GHz the limit is 500 μ V/m.

MHz

NOTES:

1. *Pol. H = Horizontal, V = Vertical
2. **AF + CL + Amp. = Antenna Factor + Cable Loss + Amplifier.
3. Measurements using CISPR quasi-peak mode.
4. The radiated emissions testing were made by rotating through three orthogonal axes. The worst date was recorded.
5. The limit is on the IC RSS GEN Clause 6.

9. TEST EQUIPMENT

No.	Instrument	Manufacturer	Model	Serial No.	Calibration Date	Calibration Interval
1	*Test Receiver	R & S	ESCS 30	833364/020	Mar. 24 2010	1 year
2	Test Receiver	R & S	ESCS 30	100302	Nov. 10 2010	1 year
3	*Amplifier	HP	8447F	2805A03427	Jul. 20 2010	1 year
4	*Amplifier	Sonoma Instrument	310N	291916	Jul. 20 2010	1 year
5	*Amplifier	R & S	SCU-26	10011	Jun. 11 2010	1 year
6	*Pre Amplifier	HP	8449B	3008A00107	Feb. 03 2010	1 year
7	*Pre Amplifier	HP	8447F	2805A03351	Oct. 06 2010	1 year
8	Spectrum Analyzer	HP	8593E	3926A04282	Nov. 10 2010	1 year
9	*Spectrum Analyzer	Agilent	E4440A	MY44303257	Jul. 20 2010	1 year
10	Spectrum Analyzer	Agilent	E4440A	MY44022567	Jun. 03 2010	1 year
11	*Spectrum Analyzer	R & S	FSP40	100361	Sep. 02 2010	1 year
12	*Loop Antenna	EMCO	6502	8911-2436	Jan. 19 2010	2 year
13	Power Meter	R & S	NRVS	835360/002	Jan. 15 2010	1 year
14	Peak Power Sensor	R & S	NRV-Z32	836019/028	Nov. 10 2010	1 year
15	*Biconical Log Antenna	ARA	LPB-2520/A	1180	Apr. 14 2010	2 year
16	*Horn Antenna	SCHWARZBECK	BBHA9120D	9120D-474	Jul. 14 2010	2 year
17	*Horn Antenna	Q-par Angus	QSH20S20	8179	Apr. 12 2010	2 year
18	*Trilog-Broadband Antenna	SCHWARZBECK	VULB 9168	9168-257	Apr. 14 2010	2 year
19	Logbicon Antenna	SCHWARZBECK	VULB9166	1067	Jul. 14 2010	2 year
20	LISN	R & S	ESH3-Z5	833874/006	Nov. 10 2010	1 year
21	LISN	R & S	ESH2-Z5	100227	Feb. 03 2010	1 year
22	*Position Controller	DAEIL EMC	N/A	N/A	N/A	N/A
23	*Turn Table	DAEIL EMC	N/A	N/A	N/A	N/A
24	*Antenna Mast	DAEIL EMC	N/A	N/A	N/A	N/A
25	*Anechoic Chamber	EM Eng.	N/A	N/A	N/A	N/A
26	*Shielded Room	EM Eng.	N/A	N/A	N/A	N/A
27	*Position Controller	Seo-Young EMC	N/A	N/A	N/A	N/A
28	*Turn Table	Seo-Young EMC	N/A	N/A	N/A	N/A
29	*Antenna Mast	Seo-Young EMC	N/A	N/A	N/A	N/A
30	*Anechoic Chamber	Seo-Young EMC	N/A	N/A	N/A	N/A
31	*Shielded Room	Seo-Young EMC	N/A	N/A	N/A	N/A

*) Test equipment used during the test

10. ACCURACY OF MEASUREMENT

The Measurement Uncertainties stated were calculated in accordance with the requirements of measurement uncertainty contained in CISPR 16-4-2 with the confidence level of 95%

1. Conducted Uncertainty Calculation

Source of Uncertainty	X_i	Uncertainty of X_i		Coverage factor k	$u(X_i)$ (dB)	C_i	$C_i u(X_i)$ (dB)
		Value (dB)	Probability Distribution				
Receiver reading	RI	± 0.1	normal 1	1.000	0.1	1	0.1
Attenuation AMN-Receiver	LC	± 0.08	normal 2	2.000	0.04	1	0.04
AMN Voltage division factor	LAMN	± 0.8	normal 2	2.000	0.4	1	0.4
Sine wave voltage	dVSW	± 2.00	normal 2	2.000	1.00	1	1.00
Pulse amplitude response	dVPA	± 1.50	rectangular	1.732	0.87	1	0.87
Pulse repetition rate response	dVPR	± 1.50	rectangular	1.732	0.87	1	0.87
Noise floor proximity	dVNF	± 0.00	-	-	0.00	1	0.00
AMN Impedance	dZ	± 1.80	triangular	2.449	0.73	1	0.73
Ⓐ Mismatch	M	+ 0.70	U-Shaped	1.414	0.49	1	0.49
Ⓑ Mismatch	M	- 0.80	U-Shaped	1.414	- 0.56	1	- 0.56
Measurement System Repeatability	RS	0.05	normal 1	1.000	0.05	1	0.05
Remark	Ⓐ: AMN-Receiver Mismatch : + Ⓑ: AMN-Receiver Mismatch : -						
Combined Standard Uncertainty	Normal			± 1.88			
Expanded Uncertainty U	Normal ($k = 2$)			± 3.76			

2. Radiation Uncertainty Calculation

Source of Uncertainty	X_i	Uncertainty of X_i		Coverage factor k	$u(X_i)$ (dB)	C_i	$C_i u(X_i)$ (dB)
		Value (dB)	Probability Distribution				
Receiver reading	RI	± 0.10	normal 1	1.000	0.10	1	0.10
Sine wave voltage	dVsw	± 2.00	normal 2	2.000	1.00	1	1.00
Pulse amplitude response	dVpa	± 1.50	rectangular	1.732	0.87	1	0.87
Pulse repetition rate response	dVpr	± 1.50	rectangular	1.732	0.87	1	0.87
Noise floor proximity	dVnf	± 0.50	normal 2	2.000	0.25	1	0.25
Antenna Factor Calibration	AF	± 1.50	normal 2	2.000	0.75	1	0.75
Attenuation Antenna-receiver	CL	± 0.52	normal 2	2.000	0.26	1	0.26
Antenna Directivity	AD	± 1.00	rectangular	1.732	0.58	1	0.58
Antenna Factor Height Dependence	AH	± 0.50	rectangular	1.732	0.29	1	0.29
Antenna Phase Centre Variation	AP	± 0.30	rectangular	1.732	0.17	1	0.17
Antenna Factor Frequency Interpolation	AI	± 0.30	rectangular	1.732	0.17	1	0.17
Site Imperfections	SI	± 4.00	triangular	2.449	1.63	1	1.63
Measurement Distance Variation	DV	± 0.10	rectangular	1.732	0.06	1	0.06
Antenna Balance	Dbal	± 0.90	rectangular	1.732	0.52	1	0.52
Cross Polarisation	DCross	± 0.90	rectangular	1.732	0.52	1	0.52
Ⓐ Mismatch	M	+ 0.25	U-Shaped	1.414	0.18	1	0.18
Ⓑ Mismatch	M	- 0.26	U-Shaped	1.414	- 0.18	1	- 0.18
Ⓒ Mismatch	M	+ 0.98	U-Shaped	1.414	0.69	1	0.69
Ⓓ Mismatch	M	- 1.11	U-Shaped	1.414	- 0.79	1	- 0.79
Measurement System Repeatability	RS	0.09	normal 1	1.000	0.09	1	0.09
Remark	Ⓐ: Biconical Antenna-receiver Mismatch : + (< 200 MHz) Ⓑ: Biconical Antenna-receiver Mismatch : - (< 200 MHz) Ⓒ: Log Periodic Antenna-receiver Mismatch : + (≥ 200 MHz) Ⓓ: Log Periodic Antenna-receiver Mismatch : - (≥ 200 MHz)						
Combined Standard Uncertainty	Normal			± 2.63 (< 200 MHz) ± 2.74 (≥ 200 MHz)			
Expanded Uncertainty U	Normal ($k = 2$)			± 5.26 (< 200 MHz) ± 5.48 (≥ 200 MHz)			