



**FCC CFR47 PART 22 SUBPART H  
FCC CFR47 PART 24 SUBPART E**

**WWAN**

**CERTIFICATION TEST REPORT**

**FOR**

**GSM/WCDMA/LTE Phone + Bluetooth/BLE and DTS b/g/n**

**MODEL NUMBER : SM-Z300F/DS**

**FCC ID: A3LSMZ300F**

**REPORT NUMBER: 15K21761-E4**

**ISSUE DATE: SEP 22, 2015**

*Prepared for*  
**SAMSUNG ELECTRONICS CO., LTD.  
129 SAMSUNG-RO, YEONGTONG-GU, SUWON-SI,  
GYEONGGI-DO, 16677, KOREA**

*Prepared by*  
**UL Korea, Ltd. Suwon Laboratory  
218 Maeyeong-ro, Yeongtong-gu,  
Suwon-si, Gyeonggi-do, 16675, Korea  
TEL: (031) 337-9902  
FAX: (031) 213-5433**



---

Revision History

<u>Rev.</u>	<u>Issue Date</u>	<u>Revisions</u>	<u>Revised By</u>
--	09/22/15	Initial issue	Junwhan Lee

## TABLE OF CONTENTS

<b>1. ATTESTATION OF TEST RESULTS</b>	<b>5</b>
<b>2. TEST METHODOLOGY</b>	<b>6</b>
<b>3. FACILITIES AND ACCREDITATION</b>	<b>6</b>
<b>4. CALIBRATION AND UNCERTAINTY</b>	<b>6</b>
4.1. MEASURING INSTRUMENT CALIBRATION	6
4.2. SAMPLE CALCULATION	6
4.3. MEASUREMENT UNCERTAINTY	6
<b>5. EQUIPMENT UNDER TEST</b>	<b>7</b>
5.1. DESCRIPTION OF EUT	7
5.2. MAXIMUM OUTPUT POWER (GSM)	7
5.3. MAXIMUM OUTPUT POWER (WCDMA)	7
5.4. MAXIMUM OUTPUT POWER (LTE)	8
5.5. DESCRIPTION OF TEST SETUP	9
<b>6. TEST AND MEASUREMENT EQUIPMENT</b>	<b>11</b>
<b>7. Summary Table</b>	<b>12</b>
<b>8. RF POWER OUTPUT VERIFICATION</b>	<b>13</b>
8.1. GSM/GPRS/EDGE	13
8.1.1. GSM OUTPUT POWER RESULT	14
8.2. UMTS REL 99	16
8.2.1. WCDMA OUTPUT POWER RESULT	20
8.3. LTE OUTPUT VERIFICATION	21
8.3.1. LTE OUTPUT POWER RESULT	22
<b>9. PEAK TO AVERAGE RATIO</b>	<b>23</b>
9.1. CONDUCTED PEAK TO AVERAGE RESULT	23
9.2. CONDUCTED PEAK TO AVERAGE PLOTS	24
<b>10. LIMITS AND CONDUCTED RESULTS</b>	<b>26</b>
10.1. OCCUPIED BANDWIDTH	26
10.1.1. OCCUPIED BANDWIDTH RESULTS	26
10.1.2. OCCUPIED BANDWIDTH PLOTS	28
10.2. BAND EDGE EMISSIONS	35
10.2.1. BAND EDGE PLOTS	37
10.3. OUT OF BAND EMISSIONS	43
10.3.1. OUT OF BAND EMISSIONS RESULT	44

---

10.3.2.	OUT OF BAND EMISSIONS PLOTS .....	46
10.4.	<i>FREQUENCY STABILITY</i> .....	53
10.4.1.	FREQUENCY STABILITY RESULTS.....	54
<b>11.</b>	<b>RADIATED TEST RESULTS .....</b>	<b>56</b>
11.1.	<i>RADIATED POWER (ERP &amp; EIRP)</i> .....	56
11.1.1.	ERP/EIRP Results .....	57
11.1.2.	ERP/EIRP DATA.....	59
11.2.	<i>FIELD STRENGTH OF SPURIOUS RADIATION</i> .....	66
11.2.1.	SPURIOUS RADIATION PLOTS.....	67
<b>12.</b>	<b>SETUP PHOTOS.....</b>	<b>74</b>

# 1. ATTESTATION OF TEST RESULTS

**COMPANY NAME:** SAMSUNG ELECTRONICS CO., LTD.  
**EUT DESCRIPTION:** GSM/WCDMA/LTE Phone + BT/BLE and DTS b/g/n  
**MODEL NUMBER:** SM-Z300F/DS  
**SERIAL NUMBER:** R38G80BH21F (RADIATED); R38G80BH2HT (CONDUCTED)  
**DATE TESTED:** SEP 04, 2015 - SEP 19, 2015

APPLICABLE STANDARDS	
STANDARD	TEST RESULTS
FCC PART 22H, 24E	Pass

UL Korea, Ltd. tested the above equipment in accordance with the requirements set forth in the above standards. All indications of Pass/Fail in this report are opinions expressed by UL Korea, Ltd. based on interpretations and/or observations of test results. Measurement Uncertainties were not taken into account and are published for informational purposes only. The test results show that the equipment tested is capable of demonstrating compliance with the requirements as documented in this report.

**Note:** The results documented in this report apply only to the tested sample, under the conditions and modes of operation as described herein. This document may not be altered or revised in any way unless done so by UL Korea, Ltd. and all revisions are duly noted in the revisions section. Any alteration of this document not carried out by UL Korea, Ltd. will constitute fraud and shall nullify the document. This report must not be used by the client to claim product certification, approval, or endorsement by IAS, any agency of the Federal Government, or any agency of any government.

Approved & Released For  
UL Korea, Ltd. By:



CY Choi  
Suwon Lab Engineer  
UL Korea, Ltd.

Tested By:



Junwhan Lee  
Suwon Lab Engineer  
UL Korea, Ltd.

## 2. TEST METHODOLOGY

The tests documented in this report were performed in accordance with TIA-603-D, FCC CFR 47 Part 22 and FCC CFR Part 24.

## 3. FACILITIES AND ACCREDITATION

The test sites and measurement facilities used to collect data are located at 218 Maeyeong-ro, Yeongtong-gu, Suwon-si, Gyeonggi-do, 16675, Korea. Line conducted emissions are measured only at the 218 address. The following table identifies which facilities were utilized for radiated emission measurements documented in this report. Specific facilities are also identified in the test results sections.

218 Maeyeong-ro	
<input type="checkbox"/>	Chamber 1
<input checked="" type="checkbox"/>	Chamber 2

UL Korea, Ltd. is accredited by IAS, Laboratory Code TL-637. The full scope of accreditation can be viewed at <http://www.iasonline.org/PDF/TL/TL-637.pdf>.

## 4. CALIBRATION AND UNCERTAINTY

### 4.1. MEASURING INSTRUMENT CALIBRATION

The measuring equipment utilized to perform the tests documented in this report has been calibrated in accordance with the manufacturer's recommendations, and is traceable to recognized national standards.

### 4.2. SAMPLE CALCULATION

Where relevant, the following sample calculation is provided:

EIRP = PSA reading with EUT worst orientation (dBm) + Path loss (dB) – cable loss( between the SG and substitution antenna) + Substitution Antenna Factor (dBi)

ERP = PSA reading with EUT worst orientation (dBm) + Path loss (dB) – cable loss( between the SG and substitution antenna)  
 (Path loss = Signal generator output – PSA reading with substitution antenna)

### 4.3. MEASUREMENT UNCERTAINTY

Where relevant, the following measurement uncertainty levels have been estimated for tests performed on the apparatus:

PARAMETER	UNCERTAINTY
Conducted Disturbance, 0.15 to 30 MHz	2.32 dB
Radiated Disturbance, Below 1GHz	4.14 dB
Radiated Disturbance, Above 1 GHz	5.97 dB

Uncertainty figures are valid to a confidence level of 95%.

## 5. EQUIPMENT UNDER TEST

### 5.1. DESCRIPTION OF EUT

The EUT is a GSM/WCDMA/LTE Phone + BT/BLE and DTS b/g/n.

### 5.2. MAXIMUM OUTPUT POWER (GSM)

The transmitter has a maximum peak conducted and radiated ERP / EIRP output powers as follows:

FCC Part 22/24						
Band	Frequency Range	Modulation	Conducted		Radiated	
	[MHz]		Peak	Avg [dBm]	Avg [mW]	Avg [dBm]
GSM850	824~849	GMSK	32.95	1972.42		
		GPRS	32.97	1981.53	28.81	760.33
		EGPRS	27.50	562.34	23.19	208.45
GSM1900	1850~1910	GMSK	30.00	1000.00		
		GPRS	30.00	1000.00	29.38	866.96
		EGPRS	26.42	438.53	23.40	218.78

### 5.3. MAXIMUM OUTPUT POWER (WCDMA)

The transmitter has a maximum peak conducted and radiated ERP / EIRP output powers as follows:

FCC Part 22/24						
Band	Frequency Range	Modulation	Conducted		Radiated	
	[MHz]		Peak	Avg [dBm]	Avg [mW]	Avg [dBm]
Band 5	824~849	REL99	22.23	167.11	16.78	47.64
		HSDPA	21.66	146.55	16.32	42.85
		HSUPA	21.30	134.90		
		DC-HSDPA	21.50	141.25		

### 5.4. MAXIMUM OUTPUT POWER (LTE)

The transmitter has a maximum peak conducted and radiated ERP / EIRP output powers as follows:

#### LTE Band 5

FCC Part 22							
Band	Frequency Range [MHz]	BandWidth [MHz]	Modulation Peak	Conducted		Radiated	
				Avg [dBm]	Avg [mW]	Avg [dBm]	Avg [mW]
Band 5	824 ~ 849	10	QPSK	23.00	199.53	14.80	30.20
			16QAM	22.30	169.82	13.70	23.44
		5	QPSK	22.95	197.24	14.84	30.48
			16QAM	22.04	159.96	14.31	26.98
		3	QPSK	22.76	188.80	14.91	30.97
			16QAM	22.24	167.49	14.38	27.42
		1.4	QPSK	22.88	194.09	12.56	18.03
			16QAM	22.25	167.88	12.08	16.14

#### DESCRIPTION OF AVAILABLE ANTENNAS

The radio utilizes a FPCB antenna for the [List the bands supported] with a maximum peak gain as follow:

Frequency (MHz)	Peak Gain (dBi)
GSM 850 / WCDMA Band 5 / LTE Band 5 824 ~ 849 MHz	-1.2
GSM 1900 1850 ~ 1910 MHz	1.1

## 5.5. DESCRIPTION OF TEST SETUP

### SUPPORT EQUIPMENT

Support Equipment List				
Description	Manufacturer	Model	Serial Number	FCC ID
Charger	SAMSUNG	ETA0U83EWE	DW1G806US/A-E	N/A
Data Cable	SAMSUNG	ECB-DU68WE	N/A	N/A
Earphone	SAMSUNG	GH59-11129H	N/A	N/A

### I/O CABLES

I/O Cable List						
Cable No	Port	# of identical ports	Connector Type	Cable Type	Cable Length (m)	Remarks
1	DC Power	1	Mini-USB	Shielded	0.8m	N/A
2	Audio	1	Mini-Jack	Unshielded	1.0m	N/A

### TEST SETUP

The EUT is continuously communicated to the call box during the tests.

**SETUP DIAGRAM FOR TESTS (CONDUCTED TEST SETUP)**

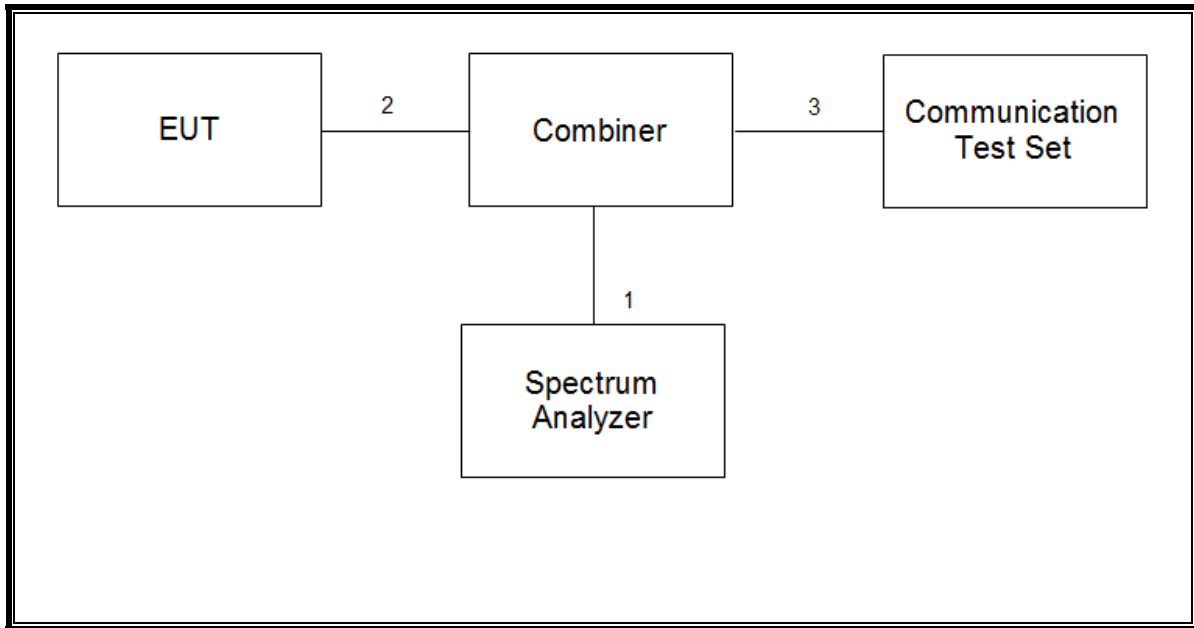

**SETUP DIAGRAM FOR TESTS (RADIATED TEST SETUP)**

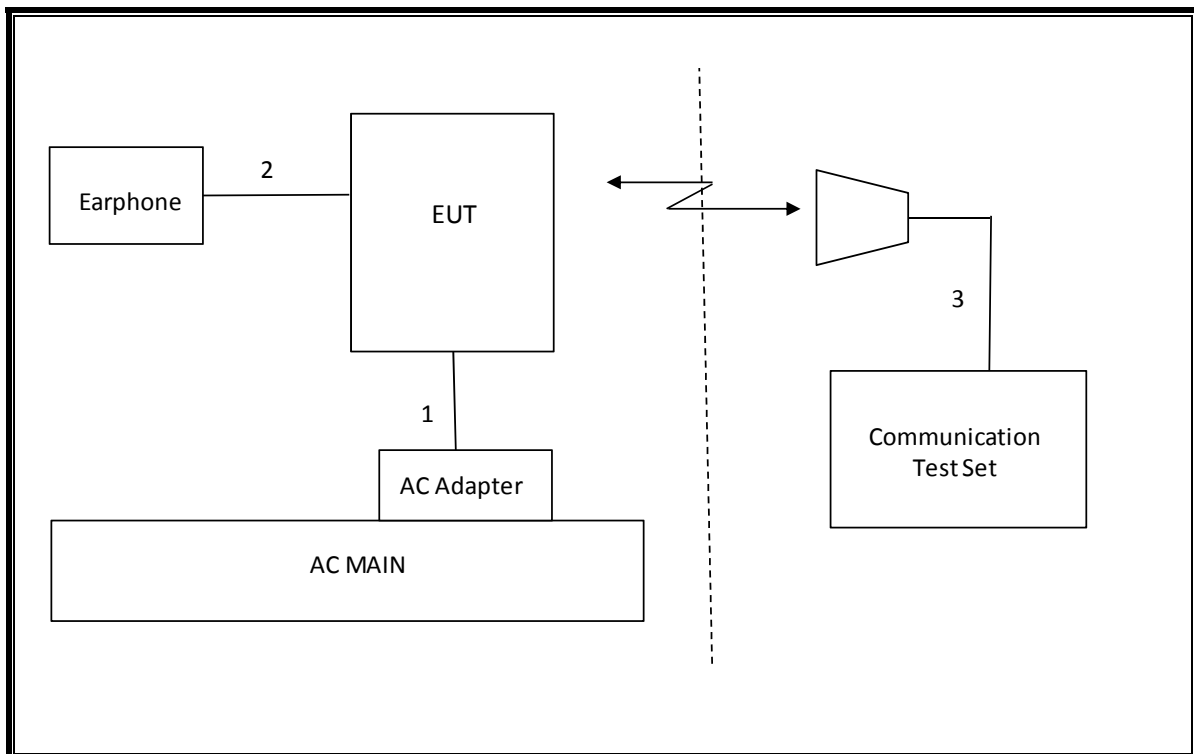

## 6. TEST AND MEASUREMENT EQUIPMENT

The following test and measurement equipment was utilized for the tests documented in this report:

Test Equipment List				
Description	Manufacturer	Model	S/N	Cal Due
Antenna, Tuned Dipole 400~1000 MHz	ETS	3121D DB4	00164753	07-28-16
Antenna, Bilog, 30MHz-1GHz	SCHWARZBECK	VULB9163	750	11-17-15
Antenna, Bilog, 30MHz-1GHz	SCHWARZBECK	VULB9163	749	04-25-16
Antenna, Horn, 18 GHz	ETS	3115	00161451	05-17-16
Antenna, Horn, 18 GHz	ETS	3117	00168724	06-17-16
Antenna, Horn, 18 GHz	ETS	3117	00168717	06-17-16
Antenna, Horn, 40 GHz	ETS	3116C	00166255	09-23-15
Antenna, Horn, 40 GHz	ETS	3116C-PA	00168841	09-29-15
Combiner	WEINSCHTEL	1575	2153	08-20-16
Communications Test Set	R&S	CMW500	150312	08-18-16
Communications Test Set	R&S	CMW500	115331	08-18-16
Communications Test Set	R&S	CMW500	102271	08-18-16
DC Power Supply	Agilent / HP	E3640A	MY54226395	08-18-16
Preamplifier, 1000 MHz	Sonoma	310N	341282	08-18-16
Preamplifier, 1000 MHz	Sonoma	310N	351741	08-18-16
Preamplifier, 18 GHz	Miteq	AFS42-00101800-25-S-42	1876511	08-18-16
Preamplifier, 18 GHz	Miteq	AFS42-00101800-25-S-42	1896138	08-18-16
Spectrum Analyzer, 44 GHz	Agilent / HP	N9030A	MY54170614	08-19-16
Spectrum Analyzer, 44 GHz	Agilent / HP	N9030A	MY54490312	08-19-16
Bluetooth Tester	TESCOM	TC-3000C	3000C000546	08-18-16
Average Power Sensor	R&S	NRZ-Z91	102681	08-18-16
Average Power Sensor	Agilent / HP	U2000	MY54270007	08-18-16
EMI Test Receive, 40 GHz	R&S	ESU40	100439	08-19-16
EMI Test Receive, 40 GHz	R&S	ESU40	100457	08-19-16
EMI Test Receive, 3 GHz	R&S	ESR3	101832	08-19-16
Attenuator / Switch driver	HP	11713A	3748A04272	N/A
Low Pass Filter 3GHz	Micro-Tronics	LPS17541	009	08-18-16
Low Pass Filter 3GHz	Micro-Tronics	LPS17541	015	08-18-16
High Pass Filter 5GHz	Micro-Tronics	HPS17542	009	08-18-16
High Pass Filter 6GHz	Micro-Tronics	HPM17543	010	08-18-16
High Pass Filter 5GHz	Micro-Tronics	HPS17542	016	08-18-16
High Pass Filter 6GHz	Micro-Tronics	HPM17543	015	08-18-16

## 7. Summary Table

FCC Part Section	Test Description	Test Limit	Test Condition	Test Result	Note
2.1049	Occupied Band width (99%)	N/A	Conducted	Pass	8.988MHz
22.917(a) 24.238(a)	Band Edge / Conducted Spurious Emission	-13dBm		Pass	-16.587dBm
2.1046	Conducted output power	N/A		Pass	32.97dBm
22.355 24.235	Frequency Stability	2.5PPM		Pass	0.016PPM
22.913(a)(2)	Effective Radiated Power	38 dBm	Radiated	Pass	28.81dBm
24.232(c)	Equivalent Isotropic Radiated Power	33dBm		Pass	29.38dBm
22.917(a) 24.238(a)	Radiated Spurious Emission	-13dBm		Pass	-20.8dBm

FCC Rule Part	Frequency Range [MHz]	Output Power [W]	Frequency Tolerance	Emission Designator	Emission Bandwidth [MHz]	Communication Type
GSM						
22H	824.2 - 848.8	0.760	2.5 ppm	241KGXW		GSM850
22H	824.2 - 848.8	0.208	2.5 ppm	243KG7W		EDGE850
24E	1850.2 - 1909.8	0.867	2.5 ppm	243KGXW		GSM1900
24E	1850.2 - 1909.8	0.219	2.5 ppm	256KG7W		EDGE1900
WCDMA						
22H	826.4 - 846.6	0.048	2.5 ppm	4M16F9W		WCDMA
LTE Band 5						
22H	829.0 - 844.0	0.030	2.5 ppm	8M99G7D	10	QPSK
22H	829.0 - 844.0	0.023	2.5 ppm	8M98D7W	10	16QAM
22H	825.5 - 847.5	0.031	2.5 ppm	2M70G7D	3	QPSK
22H	825.5 - 847.5	0.027	2.5 ppm	2M70D7W	3	16QAM

## 8. RF POWER OUTPUT VERIFICATION

### 8.1. GSM/GPRS/EDGE

Function: Menu select > GSM Mobile Station > GSM 850/900/1800/1900  
Press Connection control to choose the different menus  
Press RESET > choose all to reset all settings  
Connection Press Signal Off to turn off the signal and change settings  
Network Support > GSM+GPRS or GSM+EGPRS  
Main Service > Packet Data  
Service selection > Test Mode A – Auto Slot Config. off  
MS Signal Press Slot Config bottom on the right twice to select and change the number of time slots and power setting  
    > Slot configuration      > Uplink/Gamma  
    > 33 dBm for GPRS 850/900  
    > 30 dBm for GPRS1800/1900  
BS Signal Enter the same channel number for TCH channel (test channel) and BCCH channel  
Frequency Offset > + 0 Hz  
Mode > BCCH and TCH  
BCCH Level > -85 dBm (May need to adjust if link is not stable)  
BCCH Channel > choose desire test channel [Enter the same channel number for TCH channel (test channel) and BCCH channel]  
Channel Type > Off  
P0> 4 dB  
Slot Config > Unchanged (if already set under MS Signal)  
TCH > choose desired test channel  
Hopping > Off  
Main Timeslot > 3 (Default)  
Network Coding Scheme > CS4 (GPRS) and MCS5 ~ MCS9 (EGPRS)  
Bit Stream > 2E9-1PSR Bit Pattern  
AF/RF Enter appropriate offsets for Ext. Att. Output and Ext. Att. Input  
Connection Press Signal On to turn on the signal and change settings

### 8.1.1. GSM OUTPUT POWER RESULT

#### GSM850 Measured Results

Band	Mode	Coding Scheme	Time Slots	Ch No.	Freq. [MHz]	Max. Power	
						Burst Pwr [dBm]	Frame Pwr [dBm]
850	GSM (Voice)	CS1	1	128	824.2	32.95	23.92
				190	836.6	32.95	23.92
				251	848.8	32.61	23.58
	GPRS (GMSK)	CS1	1	128	824.2	32.96	23.93
				190	836.6	32.97	23.94
				251	848.8	32.63	23.60
			2	128	824.2	31.12	25.10
				190	836.6	31.22	25.20
				251	848.8	31.29	25.27
			3	128	824.2	29.79	25.53
				190	836.6	29.89	25.63
				251	848.8	29.74	25.48
			4	128	824.2	28.04	25.03
				190	836.6	28.04	25.03
				251	848.8	27.68	24.67
	EGPRS (8PSK)	MCS5	1	128	824.2	27.50	18.47
				190	836.6	27.50	18.47
				251	848.8	27.35	18.32
			2	128	824.2	25.63	19.61
				190	836.6	25.60	19.58
				251	848.8	25.46	19.44
			3	128	824.2	23.23	18.97
				190	836.6	23.21	18.95
				251	848.8	23.41	19.15
4			128	824.2	22.39	19.38	
			190	836.6	22.32	19.31	
			251	848.8	22.18	19.17	

**GSM1900 Measured Results**

Band	Mode	Coding Scheme	Time Slots	Ch No.	Freq. [MHz]	Max. Power	
						Burst Pwr [dBm]	Frame Pwr [dBm]
1900	GSM (Voice)	CS1	1	512	1850.2	30.00	20.97
				661	1880.0	29.74	20.71
				810	1909.8	29.83	20.80
	GPRS (GMSK)	CS1	1	512	1850.2	30.00	20.97
				661	1880.0	29.75	20.72
				810	1909.8	29.84	20.81
			2	512	1850.2	28.50	22.48
				661	1880.0	28.30	22.28
				810	1909.8	28.36	22.34
			3	512	1850.2	26.74	22.48
				661	1880.0	26.56	22.30
				810	1909.8	26.38	22.12
			4	512	1850.2	24.53	21.52
				661	1880.0	24.33	21.32
				810	1909.8	24.13	21.12
	EGPRS (8PSK)	MCS5	1	512	1850.2	26.42	17.39
				661	1880.0	26.19	17.16
				810	1909.8	26.18	17.14
			2	512	1850.2	24.35	18.32
				661	1880.0	24.15	18.13
				810	1909.8	24.11	18.09
			3	512	1850.2	22.25	17.99
				661	1880.0	22.06	17.80
				810	1909.8	21.99	17.73
4			512	1850.2	21.08	18.07	
			661	1880.0	20.85	17.84	
			810	1909.8	20.73	17.72	

## 8.2. UMTS REL 99

### Release 99 Setup Procedures used to establish the test signals

The following tests were completed according to the test requirements outlined in section 5.2 of the 3GPP TS34.121-1 specification. The DUT supports power Class 3, which has a nominal maximum output power of 24 dBm (+1.7/-3.7).

Mode	Subtest	Rel99
WCDMA General Settings	Loopback Mode	Test Mode 2
	Rel99 RMC	12.2kbps RMC
	Power Control Algorithm	Algorithm2
	$\beta_c/\beta_d$	8/15

### HSDPA Setup Procedures used to establish the test signals

The following 4 Sub-tests were completed according to Release 7 procedures in section 5.2 of 3GPP TS34.121. A summary of these settings are illustrated below:

Mode	Subtest	HSDPA	HSDPA	HSDPA	HSDPA
		1	2	3	4
W-CDMA General Settings	Loopback Mode	Test Mode 1			
	Rel99 RMC	12.2kbps RMC			
	HSDPA FRC	H-Set 1			
	Power Control Algorithm	Algorithm 2			
	$\beta_c$	2/15	11/15	15/15	15/15
	$\beta_d$	15/15	15/15	8/15	4/15
	Bd (SF)	64			
	$\beta_c/\beta_d$	2/15	12/15	15/8	15/4
	$\beta_{hs}$	4/15	24/15	30/15	30/15
MPR (dB)	0	0	0.5	0.5	
HSDPA Specific Settings	$D_{ACK}$	8			
	$D_{NAK}$	8			
	DCQI	8			
	Ack-Nack repetition factor	3			
	CQI Feedback (Table 5.2B.4)	4ms			
	CQI Repetition Factor (Table 5.2B.4)	2			
	$A_{hs}=\beta_{hs}/\beta_c$	30/15			

**HSPA (HSDPA & HSUPA) Setup Procedures used to establish the test signals**

The following 5 Sub-tests were completed according to Release 6 procedures in section 5.2 of 3GPP TS34.121. A summary of these settings are illustrated below:

	Mode	HSPA				
	Subtest	1	2	3	4	5
WCDMA General Settings	Loopback Mode	Test Mode 1				
	Rel99 RMC	12.2 kbps RMC				
	HSDPA FRC	H-Set 1				
	HSUPA Test	HSPA				
	Power Control Algorithm	Algorithm 2				Algorithm 1
	$\beta_c$	11/15	6/15	15/15	2/15	15/15
	$\beta_d$	15/15	15/15	9/15	15/15	0
	$\beta_{ec}$	209/225	12/15	30/15	2/15	5/15
	$\beta_c/\beta_d$	11/15	6/15	15/9	2/15	15/1
	$\beta_{hs}$	22/15	12/15	30/15	4/15	5/15
	$\beta_{ed}$	1309/225	94/75	47/15	56/75	47/15
CM (dB)	1	3	2	3	1	
MPR (dB)	0	2	1	2	0	
HSDPA Specific Settings	DACK	8				0
	DNAK	8				0
	DCQI	8				0
	Ack-Nack repetition factor	3				
	CQI Feedback (Table 5.2B.4)	4ms				
	CQI Repetition Factor (Table 5.2B.4)	2				
	Ahs = $\beta_{hs}/\beta_c$	30/15				
HSUPA Specific Settings	E-DPDCCH	6	8	8	5	7
	DHARQ	0	0	0	0	0
	AG Index	20	12	15	17	21
	ETFCI (from 34.121 Table C.11.1.3)	75	67	92	71	81
	Associated Max UL Data Rate kbps	242.1	174.9	482.8	205.8	308.9
	Reference E-TFCIs	5	5	2	5	1
	Reference E-TFCI	11	11	11	11	67
	Reference E-TFCI PO	4	4	4	4	18
	Reference E-TFCI	67	67	92	67	67
	Reference E-TFCI PO	18	18	18	18	18
	Reference E-TFCI	71	71	71	71	71
	Reference E-TFCI PO	23	23	23	23	23
	Reference E-TFCI	75	75	75	75	75
	Reference E-TFCI PO	26	26	26	26	26
	Reference E-TFCI	81	81	81	81	81
Reference E-TFCI PO	27	27	27	27	27	
Maximum Channelisation Codes	2xSF2				SF4	

**DC-HSDPA Setup Procedures used to establish the test signals**

The following tests were completed according to procedures in section 7.3.13 of 3GPP TS34.108 v9.5.0. A summary of these settings are illustrated below:

Downlink Physical Channels are set as per 3GPP TS34.121-1 v9.0.0 E.5.0

**Table E.5.0: Levels for HSDPA connection setup**

Parameter	Unit	Value
<b>During Connection setup</b>		
P-CPICH_Ec/Ior	dB	-10
P-CCPCH and SCH_Ec/Ior	dB	-12
PICH_Ec/Ior	dB	-15
HS-PDSCH	dB	off
HS-SCCH_1	dB	off
DPCH_Ec/Ior	dB	-5
OCNS_Ec/Ior	dB	-3.1

Call is set up as per 3GPP TS34.108 v9.5.0 sub clause 7.3.13

The configurations of the fixed reference channels for HSDPA RF tests are described in 3GPP TS 34.121, annex C for FDD and 3GPP TS 34.122.

**Table C.8.1.12: Fixed Reference Channel H-Set 12**

Parameter	Unit	Value
Nominal Avg. Inf. Bit Rate	kbps	60
Inter-TTI Distance	TTI's	1
Number of HARQ Processes	Processes	6
Information Bit Payload ( $N_{INF}$ )	Bits	120
Number Code Blocks	Blocks	1
Binary Channel Bits Per TTI	Bits	960
Total Available SML's in UE	SML's	19200
Number of SML's per HARQ Proc.	SML's	3200
Coding Rate		0.15
Number of Physical Channel Codes	Codes	1
Modulation		QPSK
Note 1: The RMC is intended to be used for DC-HSDPA mode and both cells shall transmit with identical parameters as listed in the table. Note 2: Maximum number of transmission is limited to 1, i.e., retransmission is not allowed. The redundancy and constellation version 0 shall be used.		

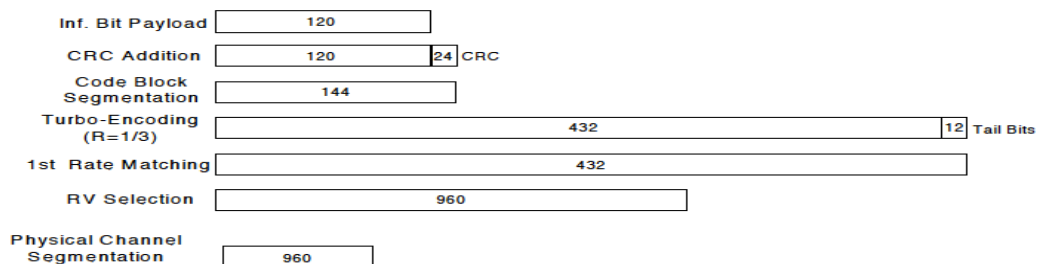

**Figure C.8.19: Coding rate for Fixed reference Channel H-Set 12 (QPSK)**

The following 4 Sub-tests for HSDPA were completed according to Release 8 procedures in section 5.2 of 3GPP TS34.121. A summary of subtest settings are illustrated below:

	Mode	HSDPA	HSDPA	HSDPA	HSDPA
	Subtest	1	2	3	4
WCDMA General Settings	Loopback Mode	Test Mode 1			
	Rel99 RMC	12.2kbps RMC			
	HSDPA FRC	H-Set 1			
	Power Control Algorithm	Algorithm2			
	$\beta_c$	2/15	11/15	15/15	15/15
	$\beta_d$	15/15	15/15	8/15	4/15
	$\beta_d$ (SF)	64			
	$\beta_c/\beta_d$	2/15	11/15	15/8	15/4
	$\beta_{hs}$	4/15	24/15	30/15	30/15
MPR (dB)	0	0	0.5	0.5	
HSDPA Specific Settings	DACK	8			
	DNAK	8			
	DCQI	8			
	Ack-Nack Repetition factor	3			
	CQI Feedback	4ms			
	CQI Repetition Factor	2			
	A <sub>hs</sub> = $\beta_{hs}/\beta_c$	30/15			

**HSPA+**

Since 16QAM is not used for uplink, the uplink Category and release is same as HSUPA, i.e., CAT 6 Rel 6. Therefore, the RF conducted power is not measured.

### 8.2.1. WCDMA OUTPUT POWER RESULT

#### WCDMA Band 5 Measured Results

Band	Mode		UL Ch No.	Freq. [MHz]	MPR [dB]	Avg Pwr [dBm]
W-CDMA Band V	Rel 99	RMC, 12.2 kbps	4132	826.4	0	22.06
			4183	836.6	0	22.23
			4233	846.6	0	22.03
	HSDPA	Subtest 1	4132	826.4	0	21.49
			4183	836.6	0	21.66
			4233	846.6	0	21.51
		Subtest 2	4132	826.4	0	21.00
			4183	836.6	0	21.14
			4233	846.6	0	21.09
		Subtest 3	4132	826.4	0.5	21.07
			4183	836.6	0.5	21.19
			4233	846.6	0.5	21.01
		Subtest 4	4132	826.4	0.5	20.93
			4183	836.6	0.5	21.13
			4233	846.6	0.5	21.00
	HSUPA	Subtest 1	4132	826.4	0	20.85
			4183	836.6	0	21.19
			4233	846.6	0	21.15
		Subtest 2	4132	826.4	2	20.00
			4183	836.6	2	19.93
			4233	846.6	2	19.93
		Subtest 3	4132	826.4	1	20.02
			4183	836.6	1	20.09
			4233	846.6	1	19.30
		Subtest 4	4132	826.4	2	20.00
			4183	836.6	2	20.00
			4233	846.6	2	20.00
		Subtest 5	4132	826.4	0	21.15
			4183	836.6	0	21.30
			4233	846.6	0	21.16
	DC-HSDPA	Subtest 1	4132	826.4	0	21.41
			4183	836.6	0	21.50
			4233	846.6	0	21.45
		Subtest 2	4132	826.4	0	21.16
			4183	836.6	0	21.28
			4233	846.6	0	21.09
		Subtest 3	4132	826.4	0.5	21.09
			4183	836.6	0.5	21.16
			4233	846.6	0.5	21.05
		Subtest 4	4132	826.4	0.5	20.95
			4183	836.6	0.5	21.17
			4233	846.6	0.5	21.04

### 8.3. LTE OUTPUT VERIFICATION

The following tests were conducted according to the test requirements outlined in section 6.2 of the 3GPP TS36.101 specification.

UE Power Class: 3 (23 +/- 2dBm). The allowed Maximum Power Reduction (MPR) for the maximum output power due to higher order modulation and transmit bandwidth configuration (resource blocks) is specified in Table 6.2.3-1 of the 3GPP TS36.101.

**Table 6.2.3-1: Maximum Power Reduction (MPR) for Power Class 3**

Modulation	Channel bandwidth / Transmission bandwidth (RB)						MPR (dB)
	1.4 MHz	3.0 MHz	5 MHz	10 MHz	15 MHz	20 MHz	
QPSK	> 5	> 4	> 8	> 12	> 16	> 18	≤ 1
16 QAM	≤ 5	≤ 4	≤ 8	≤ 12	≤ 16	≤ 18	≤ 1
16 QAM	> 5	> 4	> 8	> 12	> 16	> 18	≤ 2

The allowed A-MPR values specified below in Table 6.2.4.-1 of 3GPP TS36.101 are in addition to the allowed MPR requirements. All the measurements below were performed with A-MPR disabled, by using Network Signalling Value of "NS\_01".

**Table 6.2.4-1: Additional Maximum Power Reduction (A-MPR)**

Network Signalling value	Requirements (sub-clause)	E-UTRA Band	Channel bandwidth (MHz)	Resources Blocks ( $N_{RB}$ )	A-MPR (dB)
NS_01	6.6.2.1.1	Table 5.5-1	1.4, 3, 5, 10, 15, 20	Table 5.6-1	NA
NS_03	6.6.2.2.1	2, 4, 10, 23, 25, 35, 36	3	>5	≤ 1
			5	>6	≤ 1
			10	>6	≤ 1
			15	>8	≤ 1
			20	>10	≤ 1
NS_04	6.6.2.2.2	41	5	>6	≤ 1
			10, 15, 20	See Table 6.2.4-4	
NS_05	6.6.3.3.1	1	10, 15, 20	≥ 50	≤ 1
NS_06	6.6.2.2.3	12, 13, 14, 17	1.4, 3, 5, 10	Table 5.6-1	n/a
NS_07	6.6.2.2.3	13	10	Table 6.2.4-2	Table 6.2.4-2
	6.6.3.3.2				
NS_08	6.6.3.3.3	19	10, 15	> 44	≤ 3
NS_09	6.6.3.3.4	21	10, 15	> 40	≤ 1
				> 55	≤ 2
NS_10		20	15, 20	Table 6.2.4-3	Table 6.2.4-3
NS_11	6.6.2.2.1	23 <sup>1</sup>	1.4, 3, 5, 10	Table 6.2.4-5	Table 6.2.4-5
..					
NS_32	-	-	-	-	-

Note 1: Applies to the lower block of Band 23, i.e. a carrier placed in the 2000-2010 MHz region.

### 8.3.1. LTE OUTPUT POWER RESULT

#### LTE Band 5 Measured Results

Band	BW (MHz)	Mode	RB Allocation	RB offset	Target MPR	Avg Pwr [dBm]		
						Max. Power		
						829 MHz	836.5 MHz	844 MHz
LTE Band 5	10	QPSK	1	0	0	22.62	22.63	22.80
			1	25	0	23.00	22.60	22.41
			1	49	0	22.55	22.61	22.45
			25	0	1	21.75	21.81	21.79
			25	12	1	21.98	21.74	21.72
			25	25	1	21.73	21.65	21.62
			50	0	1	21.73	21.74	21.80
		16QAM	1	0	1	21.88	22.30	21.88
			1	25	1	22.10	22.05	21.80
			1	49	1	21.55	22.06	21.40
			25	0	2	20.80	20.95	21.00
			25	12	2	20.89	20.78	20.84
			25	25	2	20.76	20.71	20.66
			50	0	2	20.80	20.85	20.77
Band	BW (MHz)	Mode	RB Allocation	RB offset	Target MPR	Avg Pwr [dBm]		
						Max. Power		
						826.5 MHz	836.5 MHz	846.5 MHz
LTE Band 5	5	QPSK	1	0	0	22.74	22.73	22.60
			1	12	0	22.87	22.79	22.61
			1	24	0	22.95	22.71	22.53
			12	0	1	21.75	21.75	21.68
			12	7	1	21.74	21.64	21.64
			12	13	1	21.83	21.69	21.56
			25	0	1	21.76	21.67	21.68
		16QAM	1	0	1	21.56	22.04	21.79
			1	12	1	21.70	21.75	21.63
			1	24	1	21.55	21.91	21.74
			12	0	2	20.74	20.80	20.70
			12	7	2	20.83	20.68	20.68
			12	13	2	20.76	20.68	20.66
			25	0	2	20.83	20.79	20.73
Band	BW (MHz)	Mode	RB Allocation	RB offset	Target MPR	Avg Pwr [dBm]		
						Max. Power		
						825.5 MHz	836.5 MHz	847.5 MHz
LTE Band 5	3	QPSK	1	0	0	22.67	22.60	22.60
			1	8	0	22.76	22.66	22.61
			1	14	0	22.73	22.69	22.58
			8	0	1	21.74	21.69	21.63
			8	4	1	21.67	21.64	21.56
			8	7	1	21.62	21.73	21.56
			15	0	1	21.62	21.69	21.55
		16QAM	1	0	1	21.85	22.24	21.84
			1	8	1	21.77	21.81	21.32
			1	14	1	21.79	21.88	21.26
			8	0	2	20.84	20.70	20.87
			8	4	2	20.82	20.58	20.80
			8	7	2	20.62	20.67	20.80
			15	0	2	20.66	20.69	20.46
Band	BW (MHz)	Mode	RB Allocation	RB offset	Target MPR	Avg Pwr [dBm]		
						Max. Power		
						824.7 MHz	836.5 MHz	848.3 MHz
LTE Band 5	1.4	QPSK	1	0	0	22.75	22.88	22.57
			1	3	0	22.83	22.85	22.59
			1	5	0	22.70	22.74	22.51
			3	0	0	22.68	22.60	22.63
			3	1	0	22.68	22.74	22.56
			3	3	0	22.68	22.74	22.67
			6	0	1	21.60	21.63	21.49
		16QAM	1	0	1	22.17	22.07	21.65
			1	3	1	22.14	22.16	21.73
			1	5	1	22.25	22.11	21.61
			3	0	1	21.81	21.60	21.69
			3	1	1	21.63	21.64	21.47
			3	3	1	21.25	21.66	21.55
			6	0	2	20.58	20.70	20.65

## 9. PEAK TO AVERAGE RATIO

### Test Procedure

Per KDB 971168 D01 Power Meas License Digital Systems v02r02;

The transmitter output was connected to a CMW500 Test Set and configured to operate at maximum power. The PAR were measured on the Spectrum Analyzer.

### Test Spec

In addition, when the transmitter power is measured in terms of average value, the peak-to-average ratio of the power shall not exceed 13 dB.

### 9.1. CONDUCTED PEAK TO AVERAGE RESULT

#### GSM

Band	Channel	f [MHz]	Mode	Ratio [dB]	Limit [dB]
GSM850	190	836.6	GPRS	2.70	13.00
			EGPRS	5.80	
GSM1900	661	1880.0	GPRS	2.87	
			EGPRS	5.94	

#### WCDMA

Band	Channel	f [MHz]	Mode	Ratio [dB]	Limit [dB]
Band 5	4183	836.6	REL99	2.49	13.00
			HSDPA	2.95	

#### LTE Band 5

Band	BW [MHz]	Channel	f [MHz]	Mode	Ratio [dB]	Limit [dB]
Band 5	10	20525	836.5	QPSK	3.45	13.00
				16QAM	4.01	
	5			QPSK	3.25	
				16QAM	4.21	
	3			QPSK	3.49	
				16QAM	4.18	
	1.4			QPSK	3.37	
				16QAM	4.01	

## 9.2. CONDUCTED PEAK TO AVERAGE PLOTS

### GSM

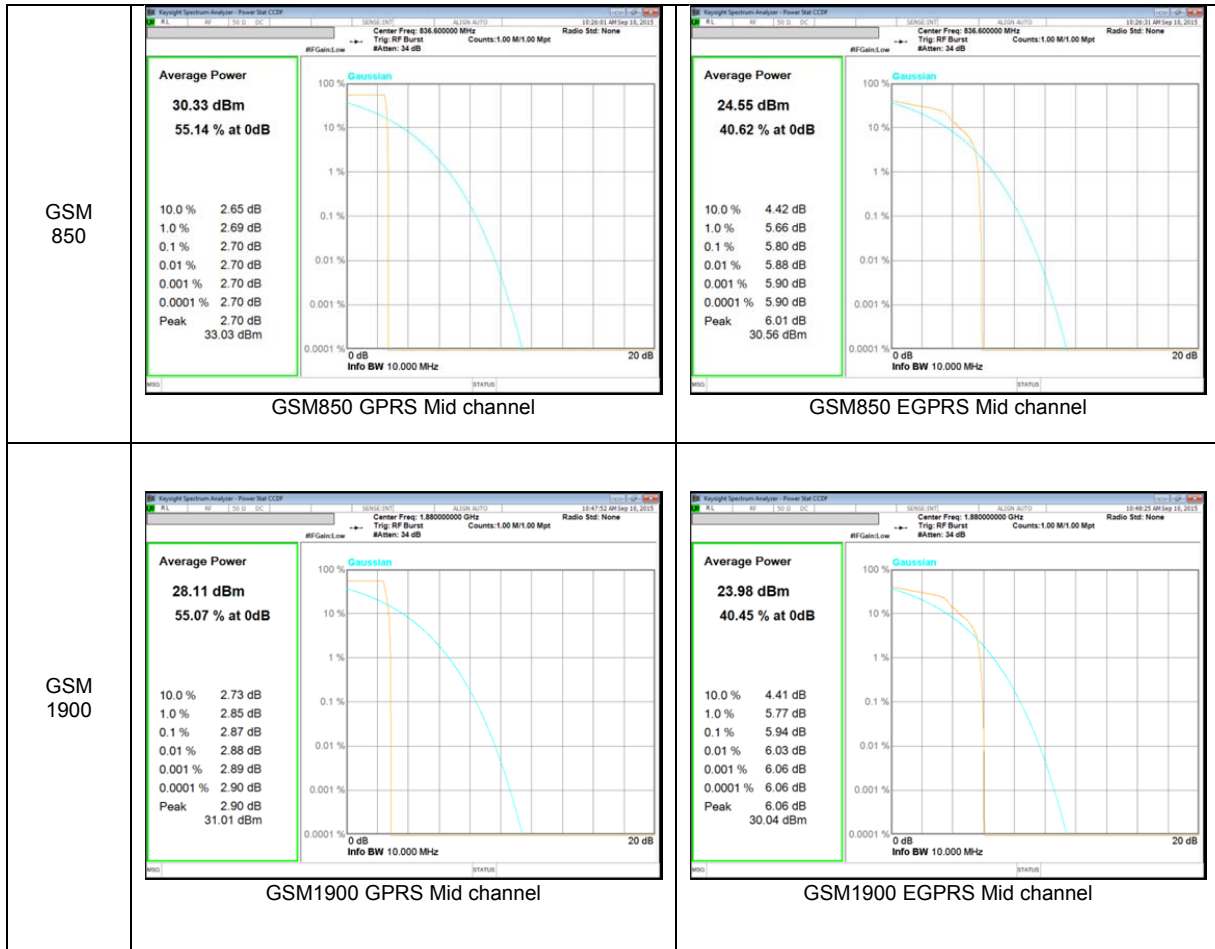

### WCDMA

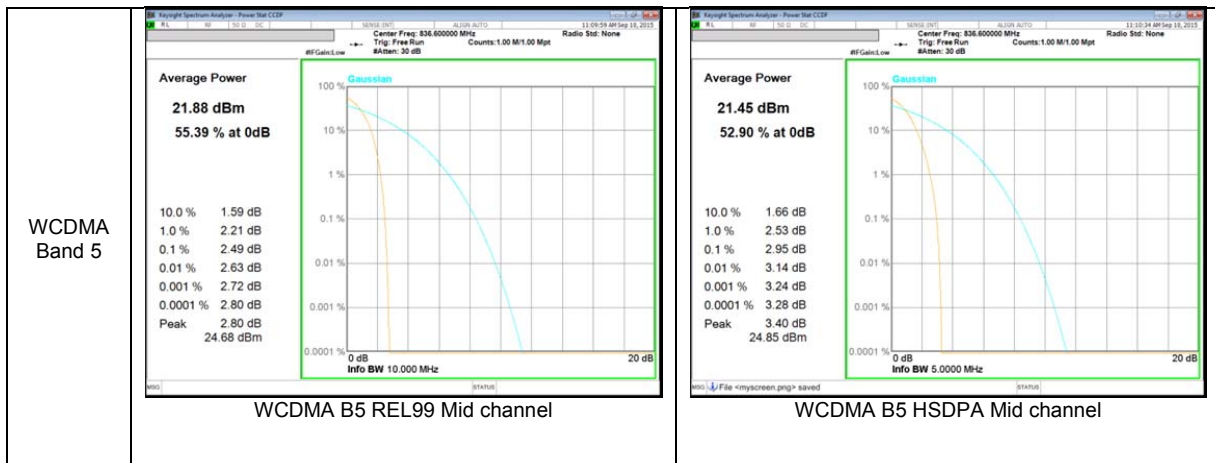

**LTE Band 5**

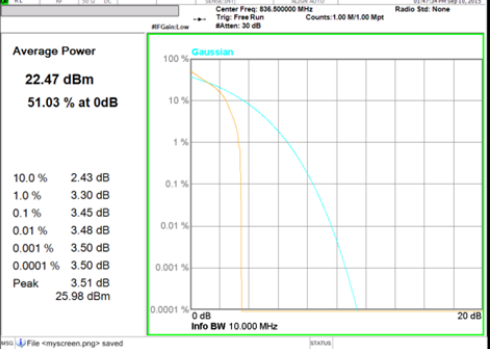
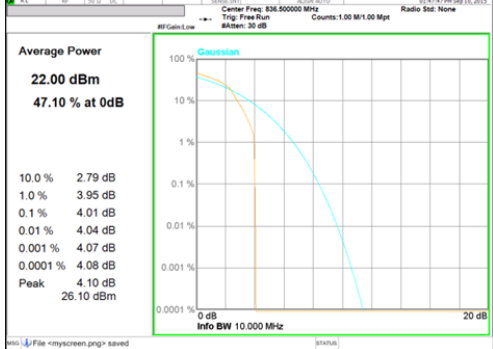
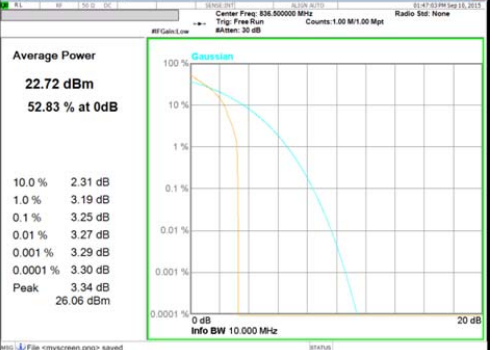
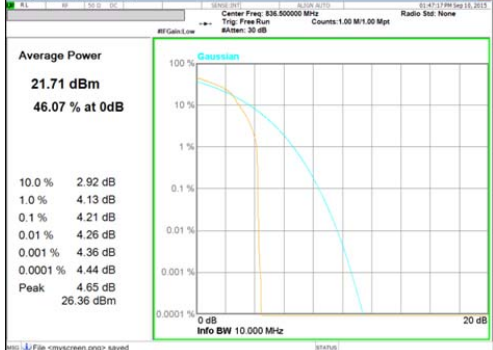
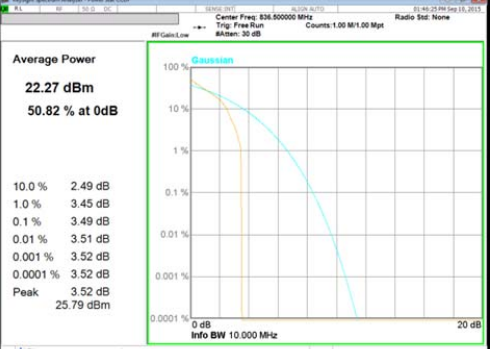
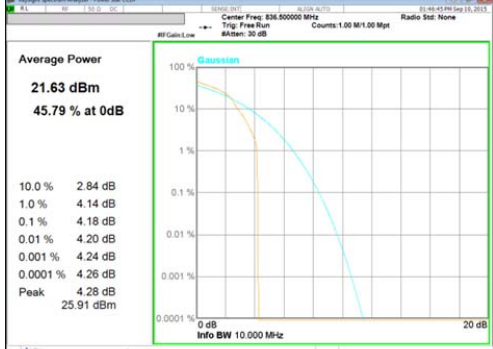
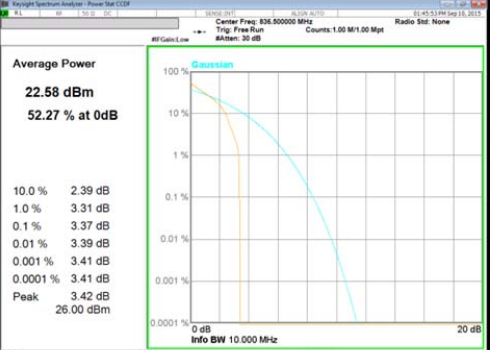
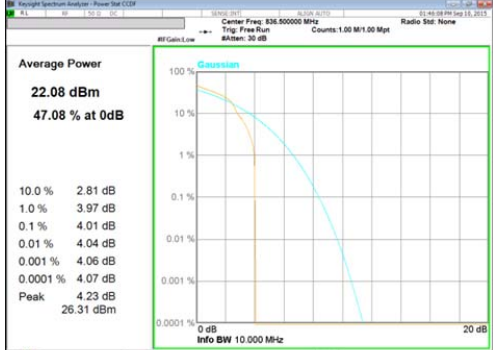
<p>LTE Band 5 10 MHz</p>	 <p><b>Average Power</b> 22.47 dBm 51.03 % at 0dB</p> <p>10.0 % 2.43 dB 1.0 % 3.30 dB 0.1 % 3.45 dB 0.01 % 3.48 dB 0.001 % 3.50 dB 0.0001 % 3.50 dB Peak 3.51 dB 25.98 dBm</p> <p>LTE B5 10MHz QPSK Mid channel</p>	 <p><b>Average Power</b> 22.00 dBm 47.10 % at 0dB</p> <p>10.0 % 2.79 dB 1.0 % 3.95 dB 0.1 % 4.01 dB 0.01 % 4.04 dB 0.001 % 4.07 dB 0.0001 % 4.08 dB Peak 4.10 dB 26.10 dBm</p> <p>LTE B5 10MHz 16QAM Mid channel</p>
<p>LTE Band 5 5 MHz</p>	 <p><b>Average Power</b> 22.72 dBm 52.83 % at 0dB</p> <p>10.0 % 2.31 dB 1.0 % 3.19 dB 0.1 % 3.25 dB 0.01 % 3.27 dB 0.001 % 3.29 dB 0.0001 % 3.30 dB Peak 3.34 dB 26.06 dBm</p> <p>LTE B5 5MHz QPSK Mid channel</p>	 <p><b>Average Power</b> 21.71 dBm 46.07 % at 0dB</p> <p>10.0 % 2.92 dB 1.0 % 4.13 dB 0.1 % 4.21 dB 0.01 % 4.26 dB 0.001 % 4.36 dB 0.0001 % 4.44 dB Peak 4.65 dB 26.36 dBm</p> <p>LTE B5 5MHz 16QAM Mid channel</p>
<p>LTE Band 5 3 MHz</p>	 <p><b>Average Power</b> 22.27 dBm 50.82 % at 0dB</p> <p>10.0 % 2.49 dB 1.0 % 3.45 dB 0.1 % 3.49 dB 0.01 % 3.51 dB 0.001 % 3.52 dB 0.0001 % 3.52 dB Peak 3.52 dB 25.79 dBm</p> <p>LTE B5 3MHz QPSK Mid channel</p>	 <p><b>Average Power</b> 21.63 dBm 45.79 % at 0dB</p> <p>10.0 % 2.84 dB 1.0 % 4.14 dB 0.1 % 4.18 dB 0.01 % 4.20 dB 0.001 % 4.24 dB 0.0001 % 4.26 dB Peak 4.28 dB 25.91 dBm</p> <p>LTE B5 3MHz 16QAM Mid channel</p>
<p>LTE Band 5 1.4 MHz</p>	 <p><b>Average Power</b> 22.58 dBm 52.27 % at 0dB</p> <p>10.0 % 2.39 dB 1.0 % 3.31 dB 0.1 % 3.37 dB 0.01 % 3.39 dB 0.001 % 3.41 dB 0.0001 % 3.41 dB Peak 3.42 dB 26.00 dBm</p> <p>LTE B5 1.4MHz QPSK Mid channel</p>	 <p><b>Average Power</b> 22.08 dBm 47.08 % at 0dB</p> <p>10.0 % 2.81 dB 1.0 % 3.97 dB 0.1 % 4.01 dB 0.01 % 4.04 dB 0.001 % 4.06 dB 0.0001 % 4.07 dB Peak 4.23 dB 26.31 dBm</p> <p>LTE B5 1.4MHz 16QAM Mid channel</p>

## 10. LIMITS AND CONDUCTED RESULTS

### 10.1. OCCUPIED BANDWIDTH

#### RULE PART(S)

FCC: §2.1049

#### LIMITS

For reporting purposes only

#### TEST PROCEDURE

The transmitter output was connected to a calibrated coaxial cable and coupler, the other end of which was connected to a spectrum analyzer. The occupied bandwidth was measured with the spectrum analyzer at the low, middle and high channel in each band. The -26dB bandwidth was also measured and recorded.

(KDB 971168 D01 Power Meas License Digital Systems v02r02)

#### 10.1.1. OCCUPIED BANDWIDTH RESULTS

##### GSM

Band	Mode	Channel	f [MHz]	99% BW [KHz]	26dB BW [KHz]
GSM850	GPRS	128	824.2	238.96	315.5
		190	836.6	239.66	312.3
		251	848.8	240.88	318.2
	EGPRS	128	824.2	243.11	324.5
		190	836.6	242.73	313.3
		251	848.8	239.75	301.2
GSM1900	GPRS	512	1850.2	243.28	314.8
		661	1880.0	241.95	317.0
		810	1909.8	243.43	316.4
	EGPRS	512	1850.2	244.87	312.5
		661	1880.0	245.40	319.5
		810	1909.8	256.23	315.7

**WCDMA**

Band	Mode	Channel	f [MHz]	99% BW [MHz]	26dB BW [MHz]
Band 5	REL99	4132	826.4	4.1644	4.614
		4183	836.6	4.1552	4.636
		4233	846.6	4.1537	4.623
	HSDPA	4132	826.4	4.1587	4.618
		4183	836.6	4.1567	4.615
		4233	846.6	4.1490	4.621

**LTE Band 5**

Band	BW [MHz]	Channel	f [MHz]	Mode	99% BW [MHz]	26dB BW [MHz]
Band 5	10	20450	829.0	QPSK	8.9881	9.799
				16QAM	8.9588	9.829
		20524	836.5	QPSK	8.9618	9.807
				16QAM	8.9810	9.792
		20599	844.0	QPSK	8.9793	9.843
				16QAM	8.9728	9.852
	5	20425	826.5	QPSK	4.5030	4.930
				16QAM	4.5008	4.981
		20524	836.5	QPSK	4.4932	4.978
				16QAM	4.4970	4.965
		20624	846.5	QPSK	4.4880	4.949
				16QAM	4.4979	4.979
	3	20415	825.5	QPSK	2.6921	2.961
				16QAM	2.6949	2.985
		20524	836.5	QPSK	2.6898	2.986
				16QAM	2.6954	2.974
		20634	847.5	QPSK	2.6994	2.982
				16QAM	2.6898	2.988
	1.4	20407	824.7	QPSK	1.0868	1.286
				16QAM	1.0934	1.298
		20524	836.5	QPSK	1.0868	1.280
				16QAM	1.0843	1.292
		20624	848.3	QPSK	1.0797	1.273
				16QAM	1.0854	1.295

**10.1.2. OCCUPIED BANDWIDTH PLOTS**  
**GSM 850**



**GSM 1900**



**WCDMA Band 5**

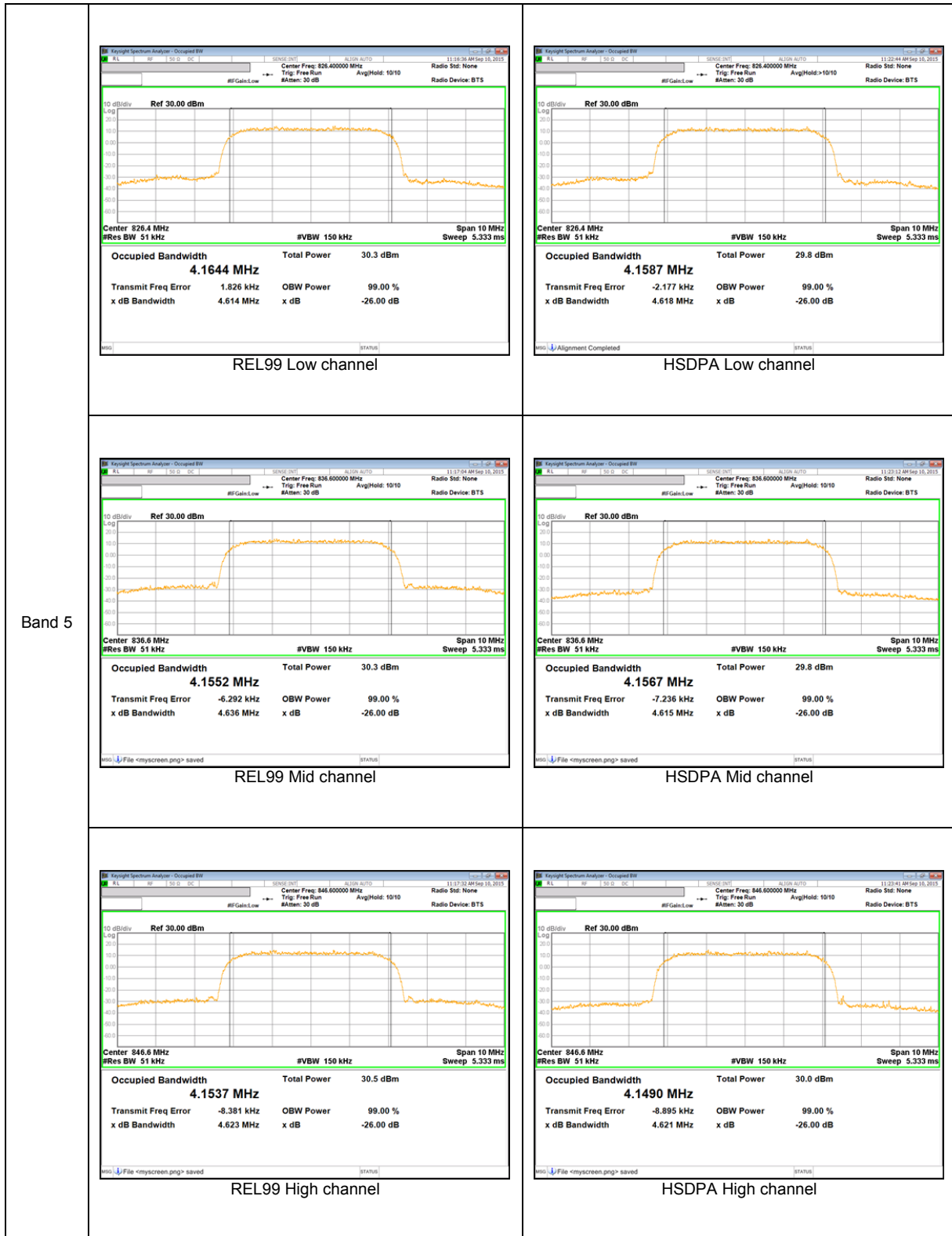

**LTE Band 5**



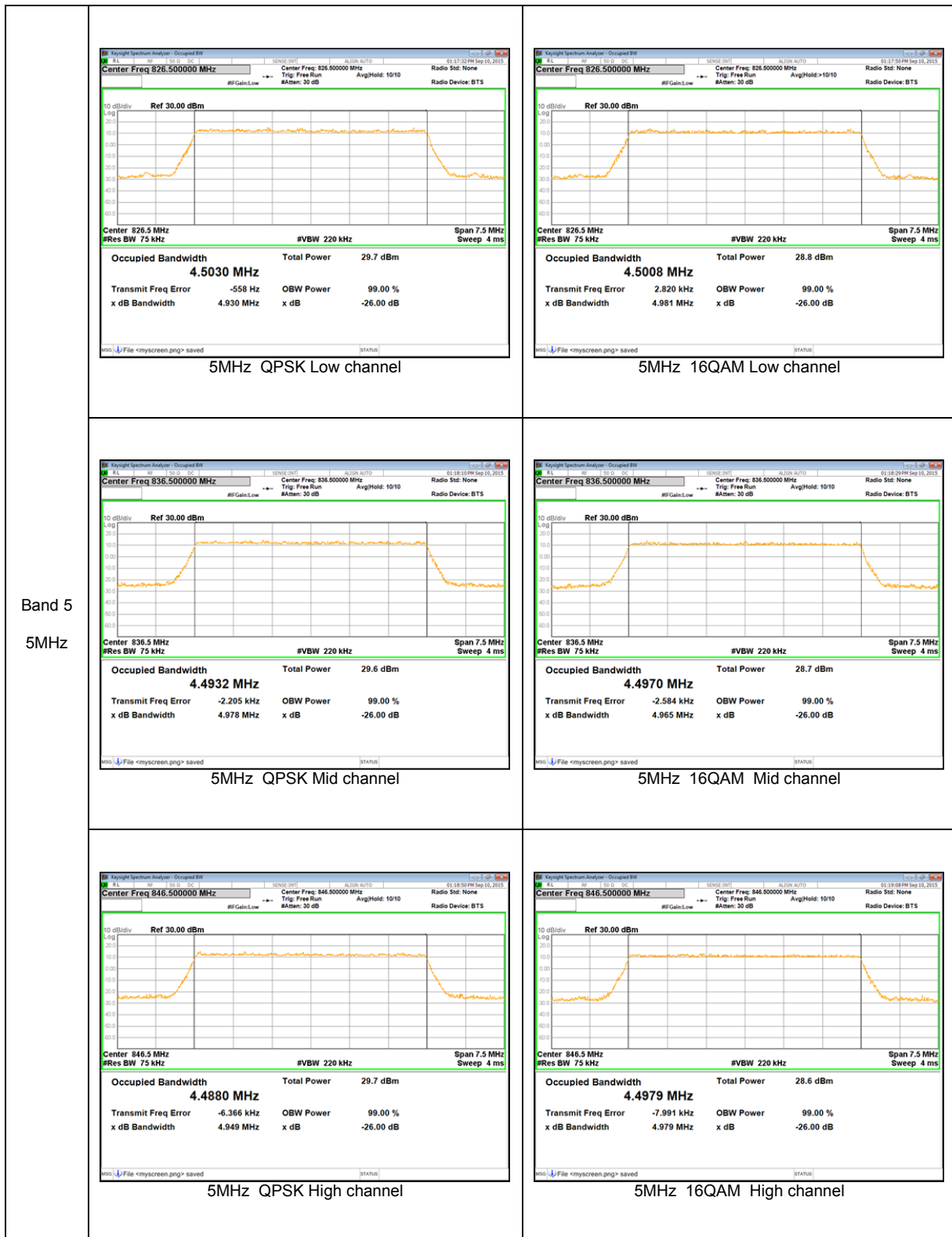

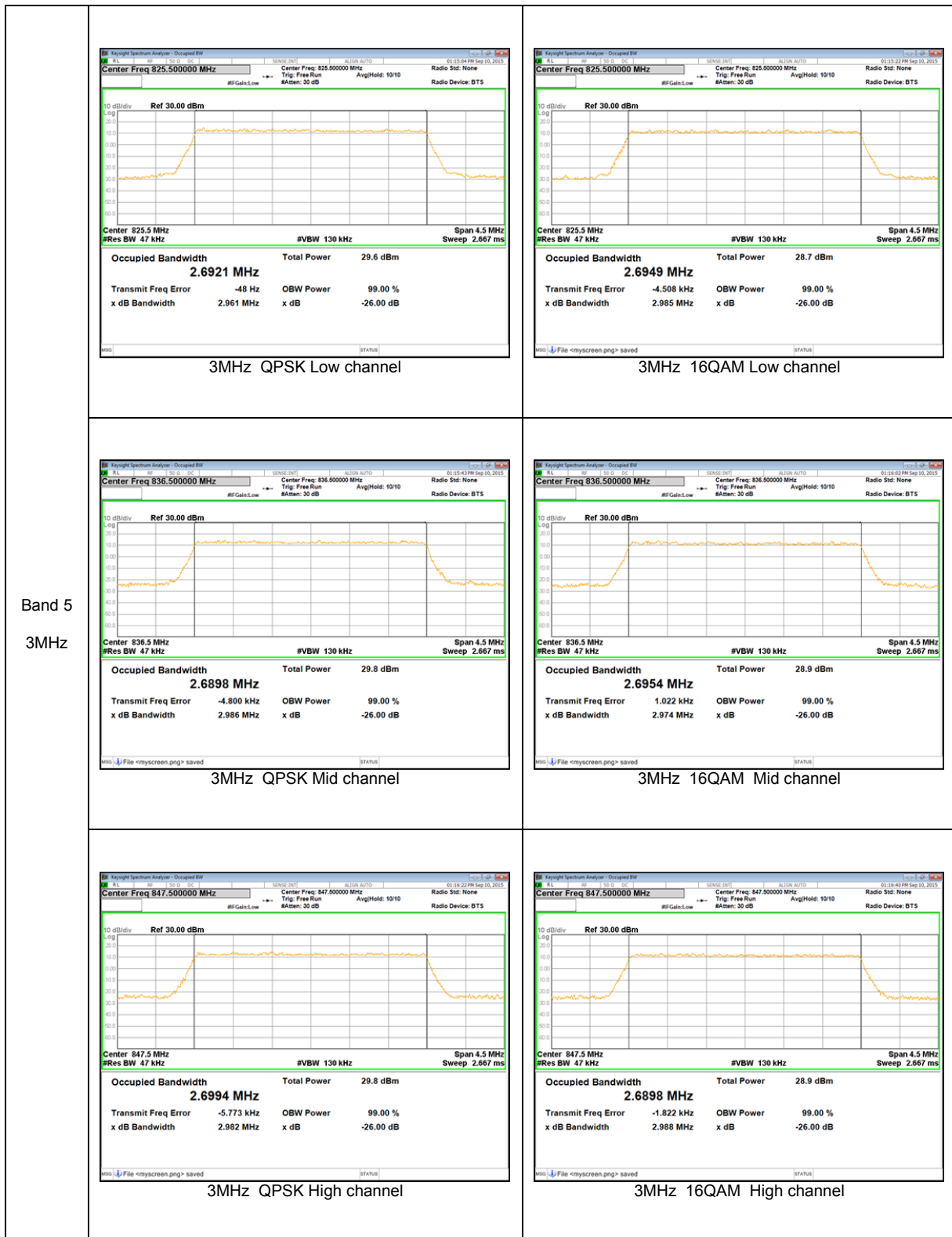

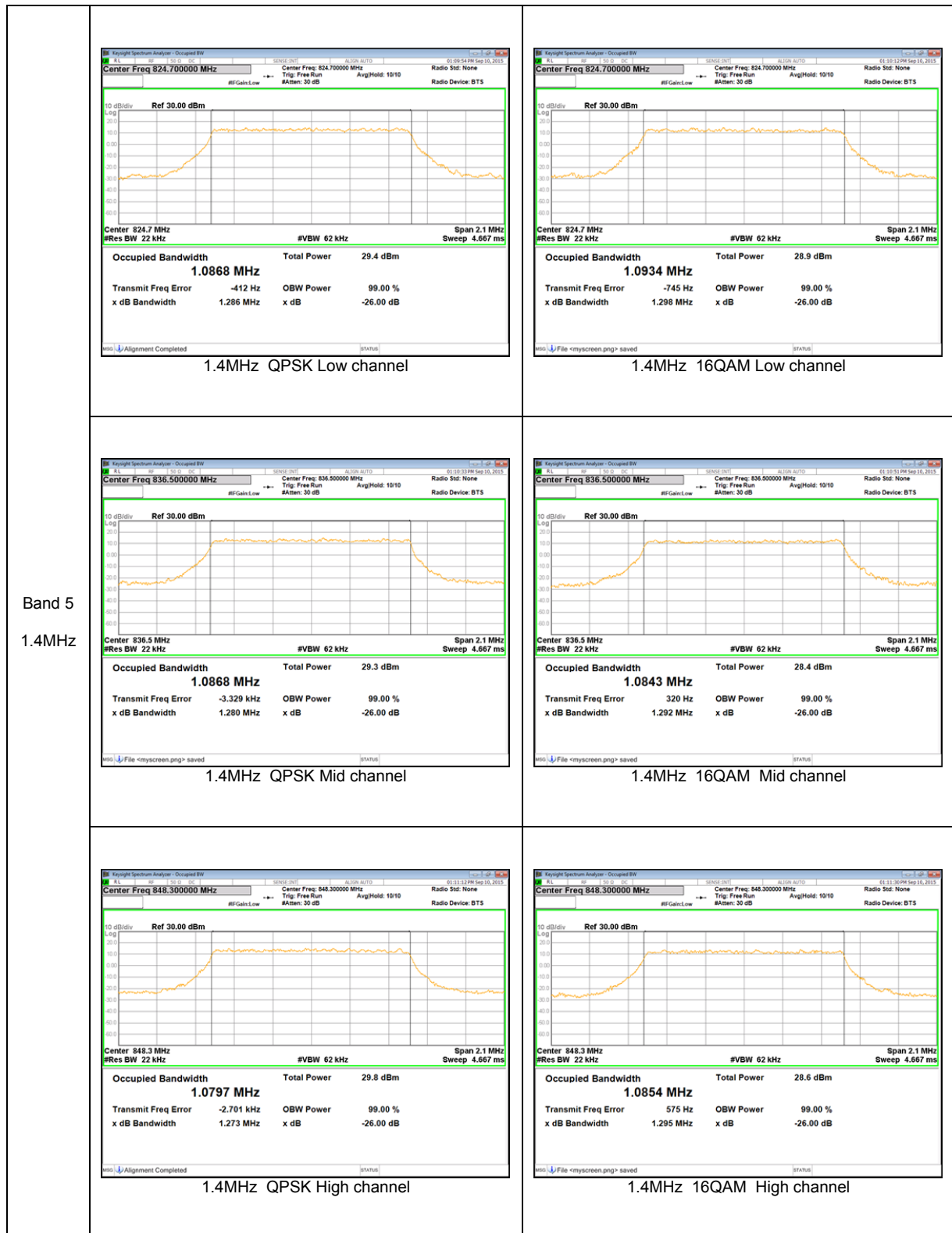

## 10.2. BAND EDGE EMISSIONS

### RULE PART(S)

FCC: §22.359, §24.238

### LIMITS

The power of any emission outside of the authorized operating frequency ranges must be attenuated below the transmitting power (P) by a factor of at least  $43 + 10 \log (P)$  dB.

### TEST PROCEDURE

Per KDB 971168 D01 Power Meas License Digital Systems v02r02

The transmitter output was connected to a CMW500 Test Set and configured to operate at maximum power. The band edge emissions were measured at the required operating frequencies in each band on the Spectrum Analyzer.

### RESULTS

#### GSM

Band	Mode	Side	f [MHz]	Level [dBm]	Limit [dBm]
GSM850	GPRS	Lower	823.9808	-23.637	-13.00
		Upper	849.0242	-23.662	
	EGPRS	Lower	823.9890	-31.634	
		Upper	849.0328	-33.566	
GSM1900	GPRS	Lower	1849.9788	-26.142	
		Upper	1910.0072	-26.177	
	EGPRS	Lower	1849.9844	-31.856	
		Upper	1910.0117	-29.366	

#### WCDMA

Band	Mode	Side	f [MHz]	Level [dBm]	Limit [dBm]
Band 5	REL99	Lower	824	-33.844	-13.00
		Upper	849	-35.719	
	HSDPA	Lower	824	-35.127	
		Upper	849	-40.009	

**LTE 5**

Bandwidth	Mode	Side	RB Status	f [MHz]	Level [dBm]	Limit [dBm]
10 MHz	QPSK	Lower	1RB	824.000	-30.848	-13.00
			FRB	824.000	-29.984	
		Upper	1RB	849.000	-30.019	
			FRB	849.000	-30.329	
	16QAM	Lower	1RB	824.000	-29.741	
			FRB	824.000	-31.446	
		Upper	1RB	849.000	-29.518	
			FRB	849.000	-32.651	
5 MHz	QPSK	Lower	1RB	824.000	-17.984	
			FRB	824.000	-29.256	
		Upper	1RB	849.000	-18.290	
			FRB	849.000	-27.208	
	16QAM	Lower	1RB	824.000	-19.256	
			FRB	824.000	-28.743	
		Upper	1RB	849.000	-21.039	
			FRB	849.000	-28.514	
3 MHz	QPSK	Lower	1RB	824.000	-19.841	
			FRB	824.000	-26.888	
		Upper	1RB	849.000	-16.587	
			FRB	849.000	-26.567	
	16QAM	Lower	1RB	824.000	-18.410	
			FRB	824.000	-29.109	
		Upper	1RB	849.000	-17.185	
			FRB	849.000	-27.575	
1.4 MHz	QPSK	Lower	1RB	824.000	-22.980	
			FRB	824.000	-29.632	
		Upper	1RB	849.000	-21.878	
			FRB	849.000	-27.925	
	16QAM	Lower	1RB	824.000	-24.446	
			FRB	824.000	-31.226	
		Upper	1RB	849.000	-23.300	
			FRB	849.000	-28.718	

### 10.2.1. BAND EDGE PLOTS

**GSM**

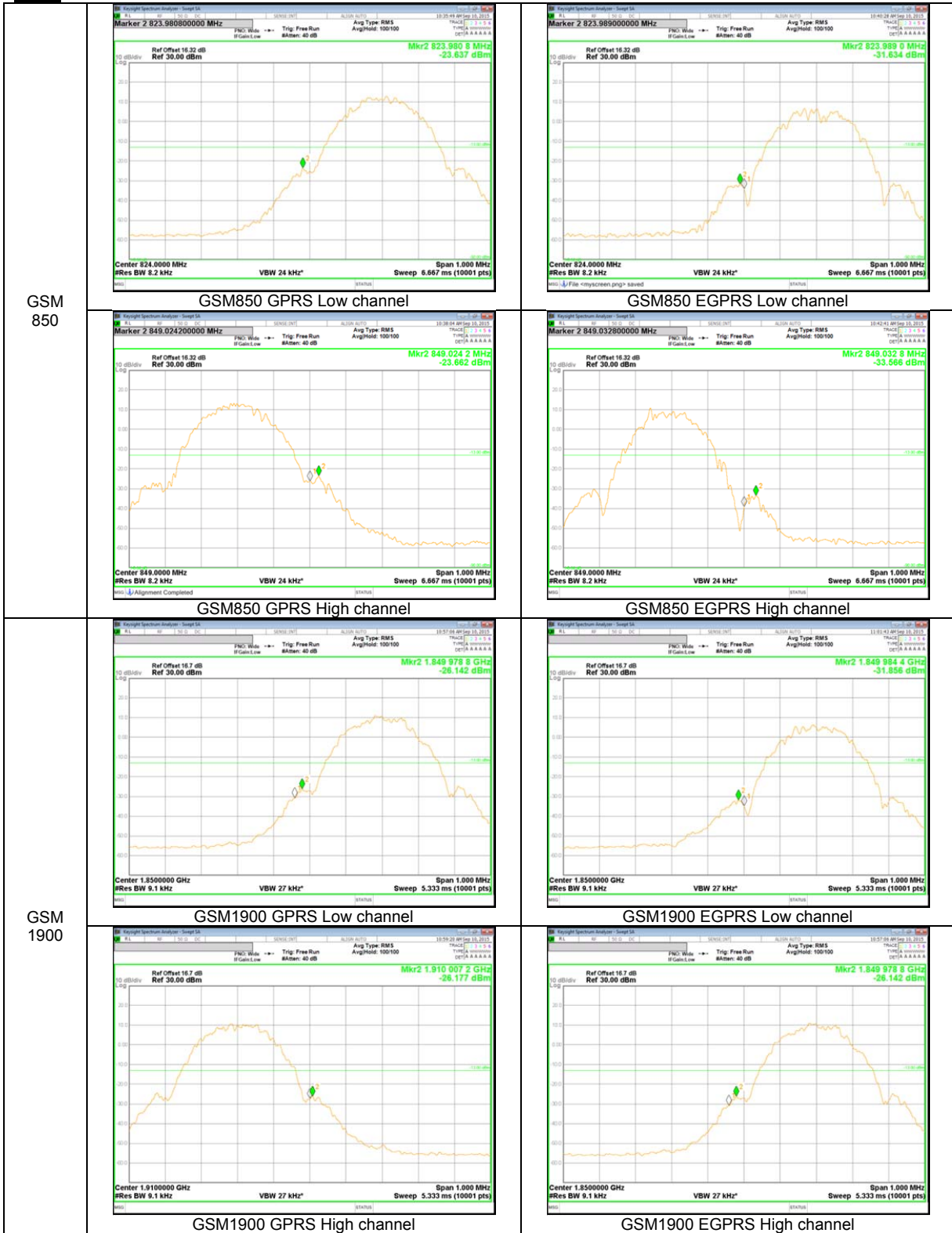

**WCDMA**

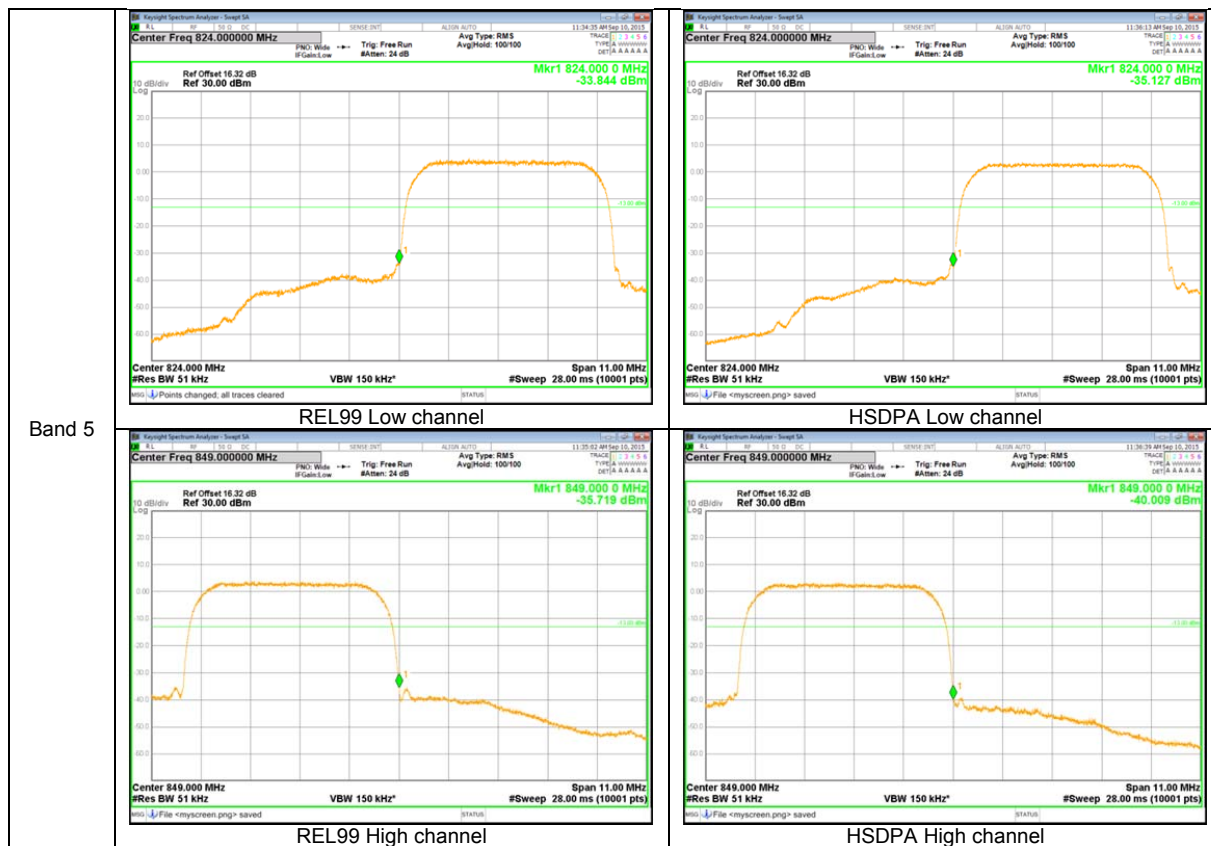

**LTE Band 5**

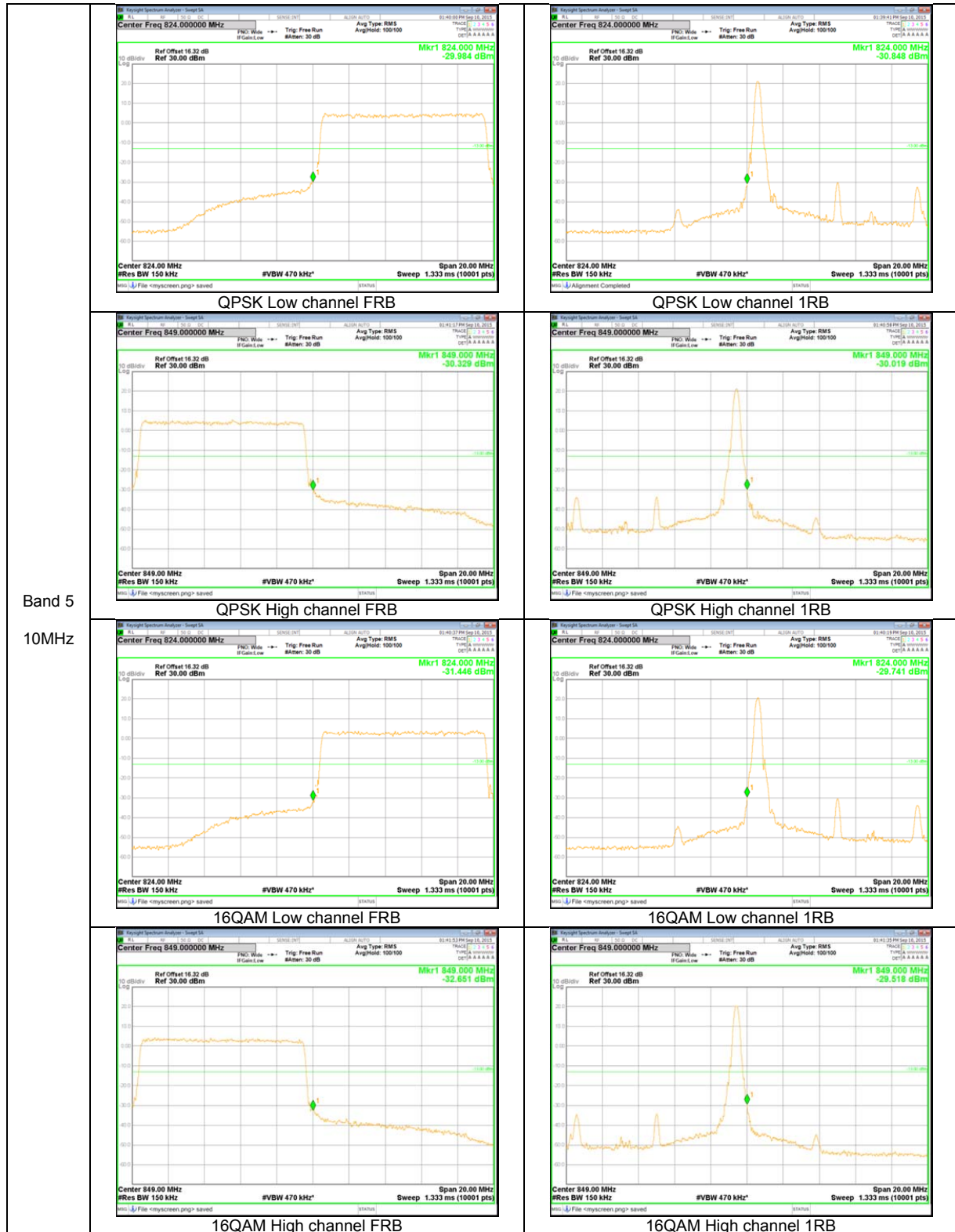

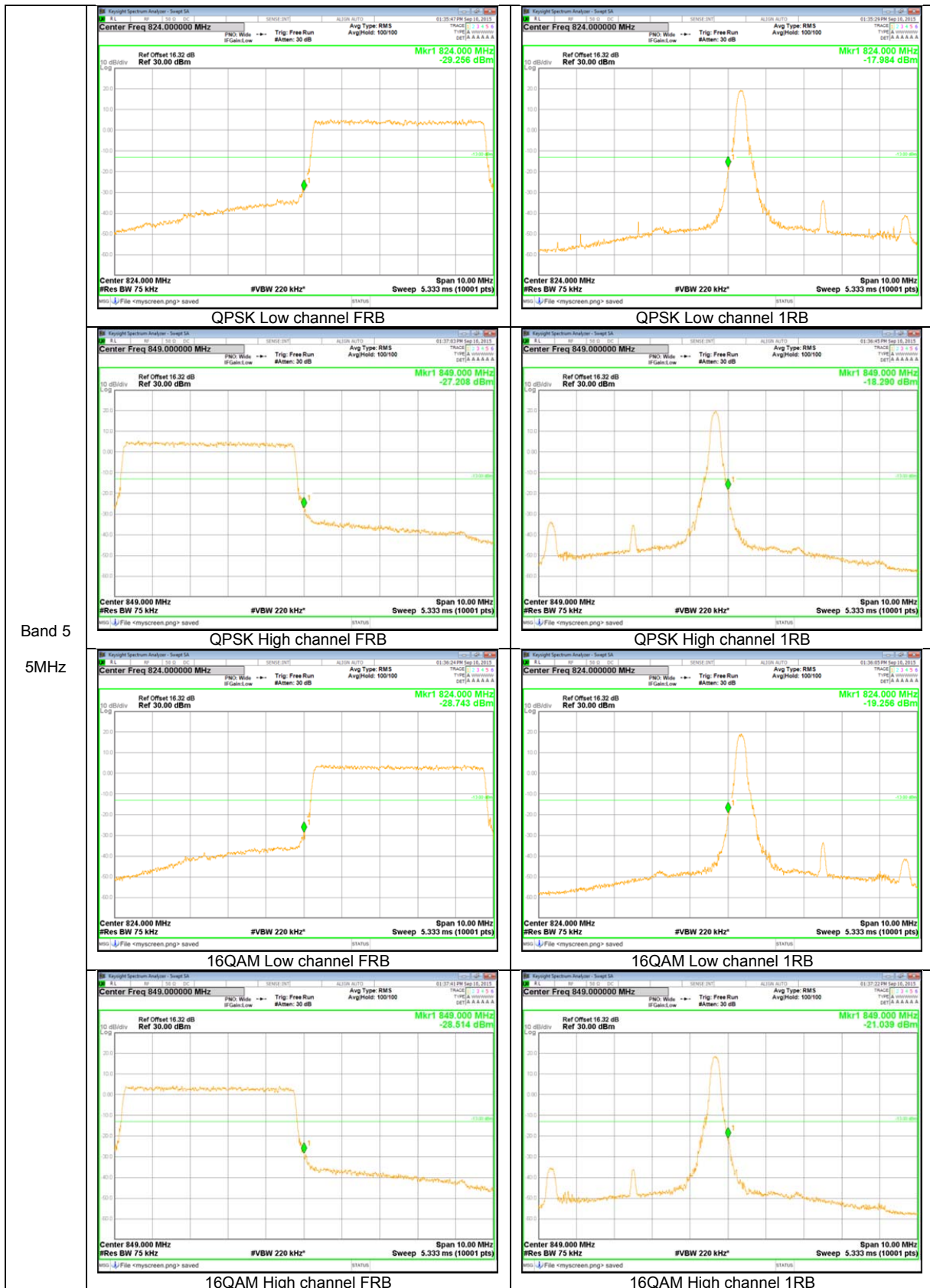

Band 5  
5MHz

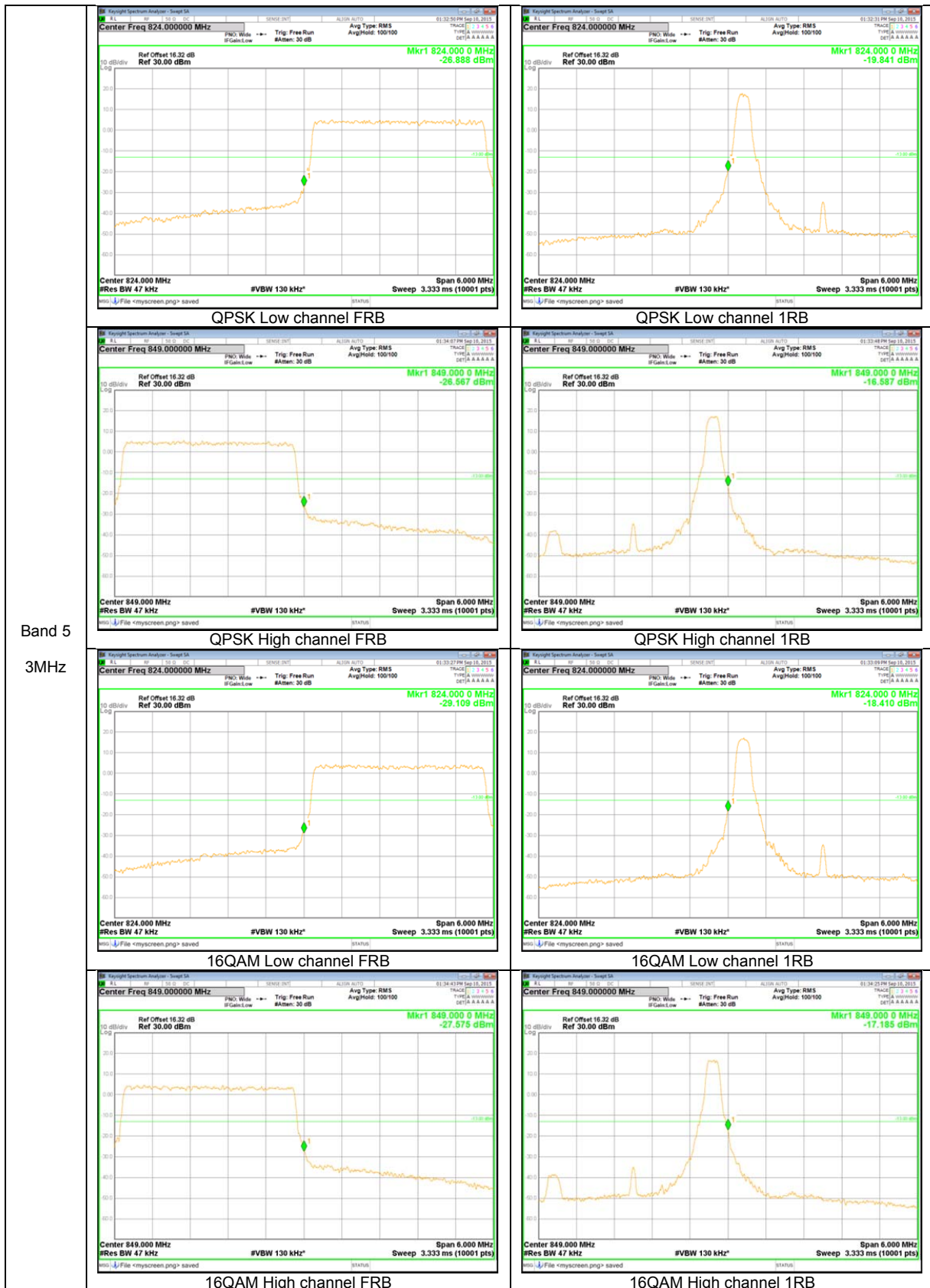

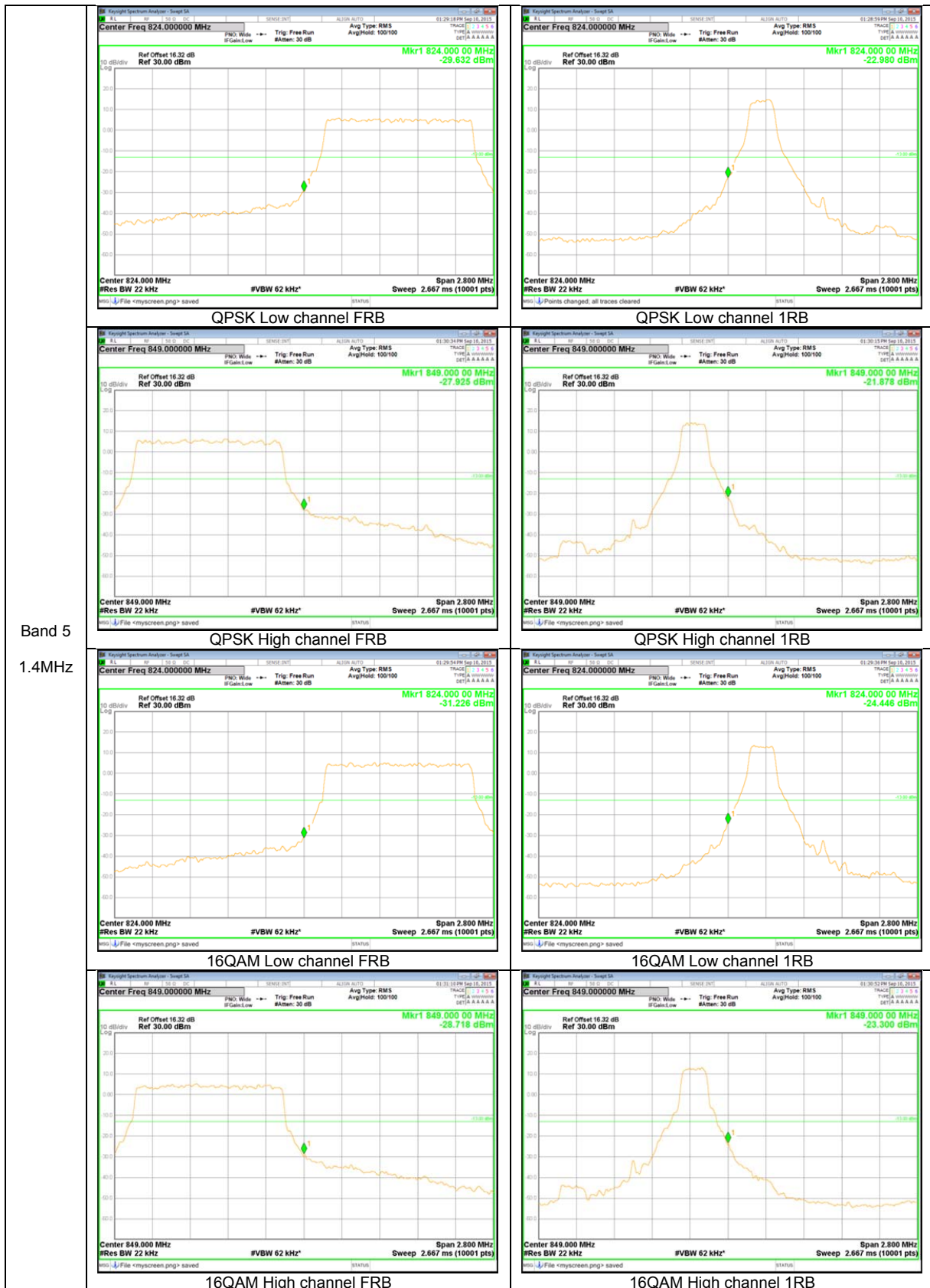

Band 5  
 1.4MHz